

STEP 5: Connect the Speakers

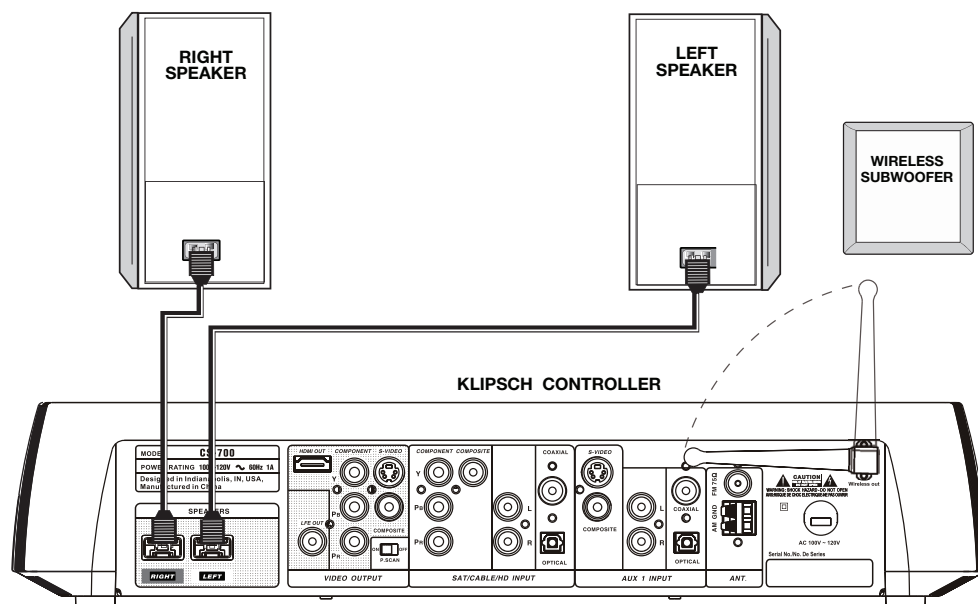

1. After you uncoil the speaker cable, connect one speaker to the RIGHT (Red) connector on the back of your Klipsch system. This speaker will be to your left when you are behind the system connecting, but it will be on the right when you are facing the system. You can connect either speaker to the LEFT or the RIGHT OUTPUT, you just need to place them properly.
2. Connect the other speaker to the LEFT (White) OUTPUT on the back of the Klipsch system. The speaker connected to the LEFT OUTPUT will be to your right when you are behind the system connecting, but it will be on the left when you are facing the system.
3. Rubber pads have been included in the Accessory box. These self adhesive pads can be applied to the bottom of the speakers.
4. The CS-700 wirelessly transmits the subwoofer signal from the A/V Center to the subwoofer. (If you wish to connect the subwoofer with a standard RCA cable, simply connect one end of the cable to the black "LFE" OUTPUT on the rear of the A/V Center and the other end to the "LFE" INPUT on the rear of the subwoofer. Cable not included.)
5. Plug the power cord into the subwoofer and an AC outlet and turn the subwoofer ON.
6. For best results, the antenna on the rear of the CS-700 A/V Center should be pointed up.

Input and Output Jacks

Please see appendix I (page 28) for the basics on how input and output jacks work with your Klipsch system.

Speaker Setup Considerations

- Front speakers typically sound best when their tweeters are at approximately ear height for seated listeners. If this isn't possible, it is sometimes beneficial to tilt the speaker down or up slightly so that it is aimed into the listening area.
- If possible, position the speakers the same distance apart as they are from the listening position.
- Speakers should be pointed straight forward. Do not place the speakers at an angle.
- If you are putting speakers in a cabinet, on a rack or a table, try to bring them out far enough so that they are at least flush with the cabinet's front edge.
- When practical, arrange each speaker so that it is at somewhat different distances from the floor, the wall behind it, and the wall beside it. It can also help to have the left and right front speakers at different distances from their nearest side walls. This staggering helps smooth the bass range. Each speaker can be set on its bottom or side. If you set them on the side and want to turn the Klipsch logo, carefully pull the logo forward, turn and release it.
- The subwoofer's output will increase as it is moved closer to walls, with maximum output when it is placed in a corner. If practical, always place the subwoofer near a wall. Additionally, a subwoofer will deliver the smoothest bass response when placed near a wall away from openings, such as doors.
- Naturally, there are exceptions to the rules, since no two rooms or systems are exactly alike. Experiment with positioning to get the best sound.

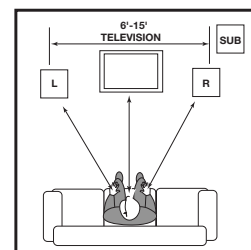

STEP 6: Connect other components (OPTIONAL)

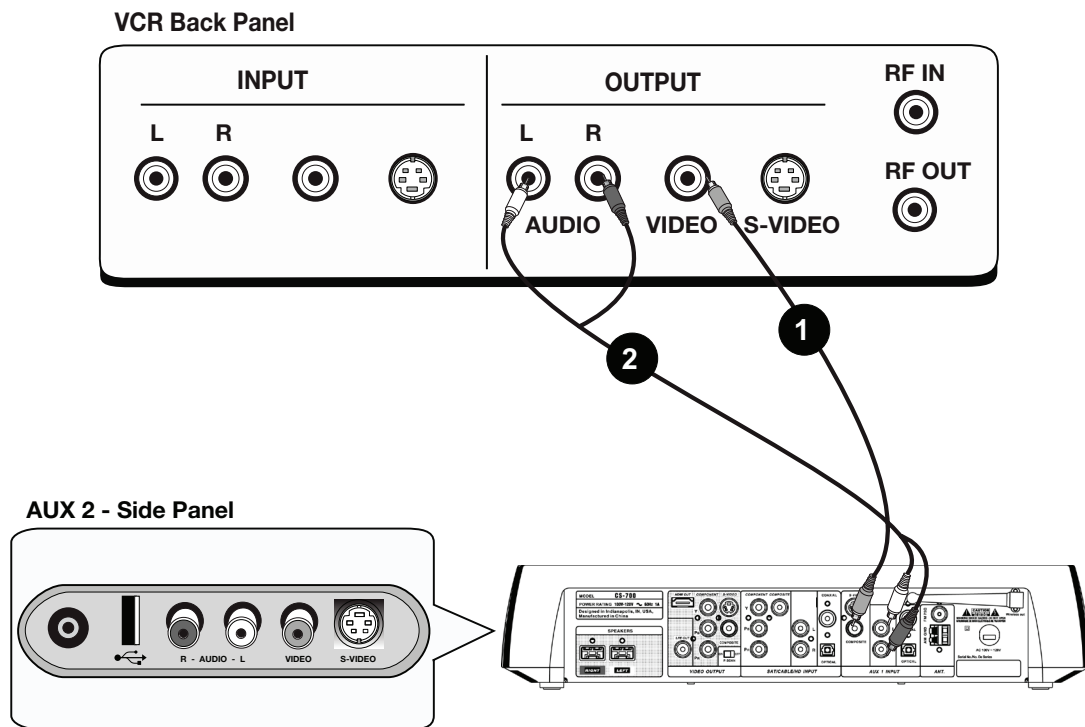

You can connect other components, such as a VCR, another recording device (like a hard-disk drive product or DVD Recorder), or a video game system to your Klipsch system using the AUXILIARY (AUX) INPUTS.

Connecting a component to AUX 1 INPUT

1. From the component's output jacks, connect the best available video option to the Klipsch system's AUX 1 INPUT video jacks.
2. Do the same thing for the audio connection. Choose the best available connection from the component's AUDIO OUTPUT jacks, and connect appropriate cables. Connect the cable(s) to the Klipsch system's AUX 1 INPUT audio jacks.

Connecting a component to AUX 2 INPUT (side)

The AUX 2 INPUT jacks on the side of your Klipsch system were designed for convenience when connecting temporary components, such as a video game system or a digital camera/camcorder.

1. From the component's output jacks, connect the best available video option.
2. Do the same thing for the audio connection. Choose the best available connection from the component's output's output jacks, and connect the appropriate cable.

Connecting headphones to HEADPHONE OUTPUT

For private listening, connect compatible headphones to the HEADPHONE jack on the side of the Klipsch system.

Connecting a device with USB to USB connector

Connect a device with USB OUTPUT to the Klipsch system's USB INPUT connector. This port is only for compatible USB flash memory drives. It is not suitable for direct connection to a computer, or to digital cameras.

Note: This USB port is a part of the "DISC" Source, not Aux 2.

Input and Output Jacks

Please see appendix I (page 28) for the basics on how input and output jacks work with your Klipsch system.

STEP 7: Connect AM and FM Antennas (supplied)

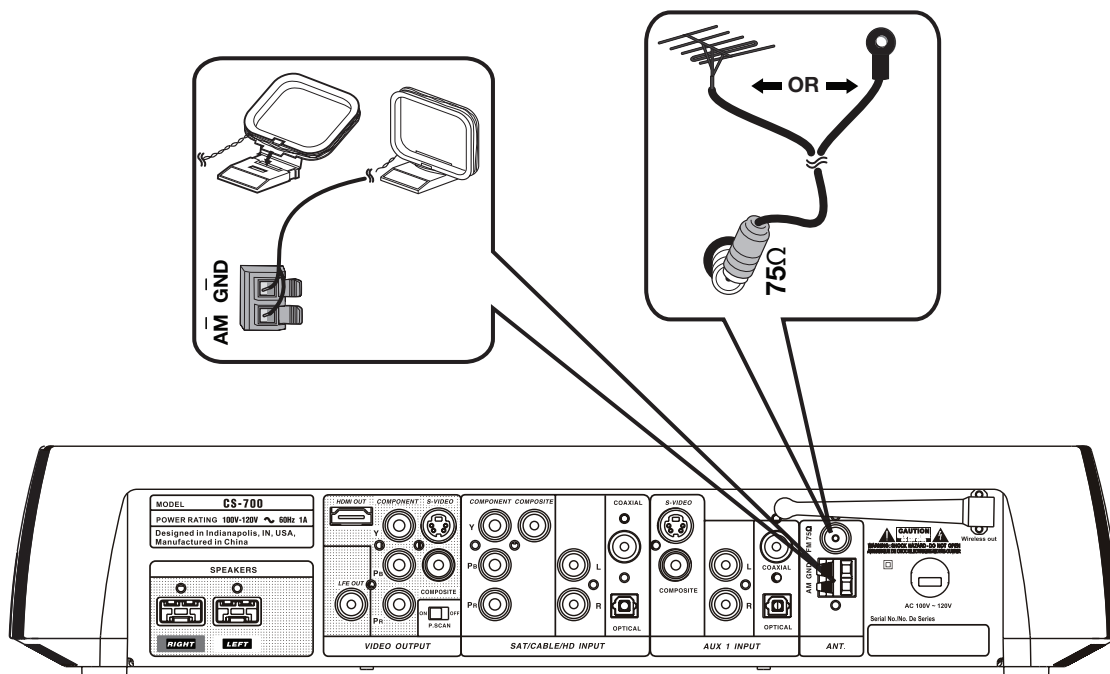

The back of your Klipsch System has jacks for the AM and FM antennas that were packed with your system. Unwind the wires for each antenna to provide the best reception. An outdoor antenna may be used in place of the supplied indoor antennas. To add an outdoor antenna, consult a qualified installer. Follow all safety instructions supplied with the antenna.

FM Antenna

Plug the FM antenna into the Klipsch system's FM (75Ω) jack in the section labeled ANT. On the back of your Klipsch system, spread out the antenna arms and move them around to establish optimum FM reception. Extend the antenna as much as possible.

Some cable TV providers make FM radio signals available through the cable service to your home. This connection is made to the external FM jack on the back of the Klipsch system. To connect to this service, contact your cable TV provider for assistance.

Make sure that the cable radio installation includes a TV/FM splitter so that only the FM radio band, not the cable TV band, is received by the Klipsch system. If necessary, contact your cable company.

AM Antenna

Plug the AM loop antenna into the AM GND jack in the section labeled ANT on the back of your Klipsch system. Place the antenna loop at least 20 inches (50 centimeters) away from your Klipsch system. To get optimum reception, you may need to experiment with the positioning of the loop antenna.

STEP 8: Turn on the TV and the Klipsch System

1. Plug in the Klipsch system's power cord to an AC power outlet.
2. Turn on the Klipsch system (press the ON/OFF button on the front panel or on the remote control). You can also press DISC on the remote.
3. Turn on the TV and tune to the correct video input channel. This is the channel that corresponds to the input jack you used on the back of the TV to connect the Klipsch system. The name and how you access this video input channel varies for different TVs. Generally, you will press a button on the TV's remote control, such as SOURCE or INPUT or VID. See below if you can't find the correct input channel on your TV.

Set TV to the Right Channel

If you do not see a picture on your TV, check your TV's owner manual to see how you tune the TV to the correct channel. It won't be "Channel 3" but it's the same idea. You'll need to tune the TV to the "channel" that matches the input jacks on the TV you used to connect to the Klipsch system's output jacks (either COMPONENT, S-VIDEO, or COMPOSITE—which is regular VIDEO and color-coded yellow). Below are some ideas to try if you can't find the answer in the TV manual.

Button on TV Remote	Channel Number of TV			Button on TV
SOURCE	00	90	91	SOURCE
INPUT	92	93	VID 1	INPUT
LINE	VID	SVID	CMPNT	LINE
VIDEO				VIDEO
VID	You might have to press the TV's channel down button until you get to the correct video channel.			VID

STEP 9: Complete the On-screen Setup

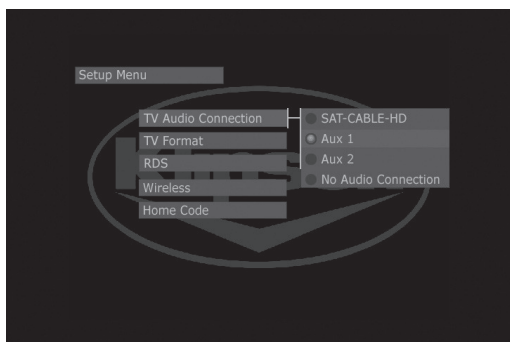
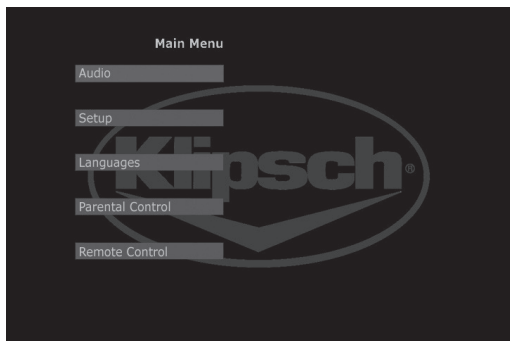

1. Press **MENU** on your Klipsch system remote control (the main menu appears).

2. Press arrow down ▼ to highlight **Setup** and press **ENTER** (the **Setup** menu items appear).

Match the on-screen option with the cables that are connected to each of the jacks on your Klipsch system. This information tells the system what is connected to it, and which cables and jacks were used.

3. **TV Audio Connection:** If you made a TV Audio connection, use the arrow button to select where you connected the TV's AUDIO OUTPUT to the Klipsch system's AUDIO INPUT. Use the ▲ or ▼ arrow button to highlight the correct option and press **ENTER**.

SAT/CABLE/HD: Choose this option if you connected audio from the TV to one of the three AUDIO INPUT options in the SAT/CABLE/HD INPUT section on the back of the Klipsch system.

AUX 1: Choose this option if you connected audio from the TV to one of the audio options in the AUX 1 INPUT section on the back of the Klipsch system.

AUX 2: Choose this option if you connected the TV's audio to one of the AUX 2 INPUT audio options on the side of the Klipsch system.

No Audio Connection: Choose this option if you didn't connect the audio from the TV to the Klipsch system. You'll only hear audio from the Klipsch system when you're playing the radio or a disc, or through one of the components connected to the Klipsch System (e.g., VCR, DVD Recorder, mp3 player, etc.).

Note: If you connected the audio from the TV's AUDIO OUTPUT jacks to the Klipsch system, you'll need to turn off your TV's internal speakers and may need to adjust the audio setting in the TV's menu system. Locate your TV manual to get specific instructions, as the procedures differ for different brands and types of televisions.

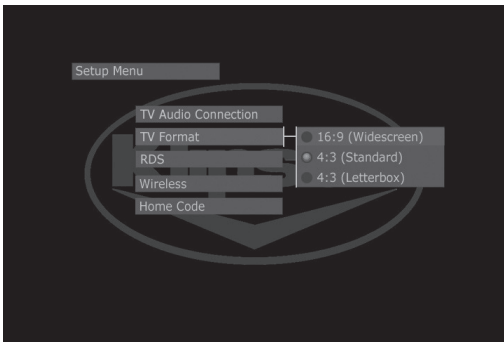

4. **TV Format:** TV Format lets you choose between a standard TV screen and a Widescreen option. The Widescreen option has an aspect ratio of 16:9. If your TV has a 4:3 aspect ratio, select either the Standard or Letterbox option depending on your preference.

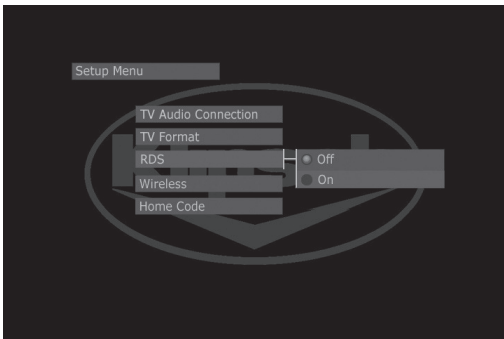

5. **RDS (Radio Data System):** RDS is the system that allows broadcasters to embed programming information in to the radio signal, such as the name of the artist or song. Your Klipsch system is RDS-enabled.

If you want to turn on RDS, choose **On** and press ENTER (the name of the radio station will appear on the Klipsch display).

Note: On most U.S. radio stations, artist and title information will appear with the "Station ID."

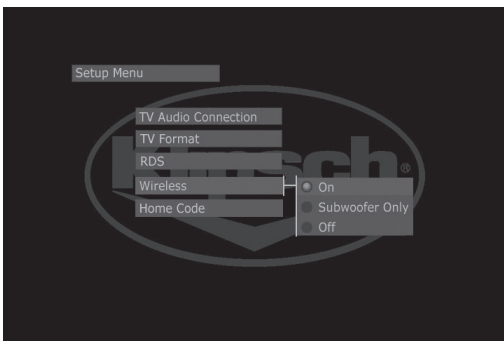

6. **WIRELESS:** Your Klipsch CS-700 system uses KlipschCast wireless technology to transmit the subwoofer signal from the A/V center to the subwoofer. The system is also capable if using KlipschCast to transmit any of its sources, on-board or auxiliary, throughout your home in CD quality. This signal can then be received and played by other Klipsch audio products using KlipschCast technology.

Selecting **Subwoofer Only** turns off the wireless broadcast to all KlipschCast components except the CS-700 subwoofer. For example, this might be done when viewing/listening to content on the CS-700 that you do not wish to broadcast to other KlipschCast components.

Selecting **All Off** will disable all wireless transmission including the subwoofer signal. This is primarily used for diagnostics.

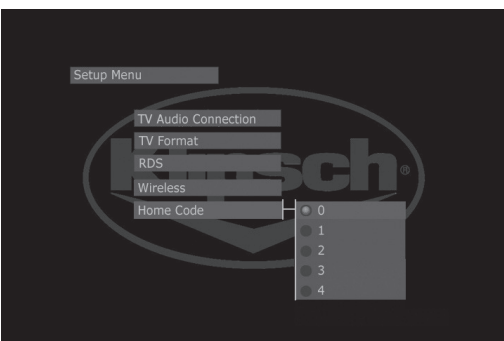

7. **HOME CODE:** The **Home Code** feature allows you to select a unique channel for all your KlipschCast components to keep your content private and unavailable to other nearby systems. The **Home Code** default is **0** for all KlipschCast components and does not need to be changed unless other nearby KlipschCast systems interfere. All KlipschCast components (including your subwoofer) in your multi-room system must be on the same home code to interact with one another. To check or change the home code on the CS-700, select **Home Code** in the **Setup Menu**. From here you can see the selected **Home Code** and change it if necessary.

To check or change the **Home Code** on your subwoofer, find the **Home Code** dial on the rear of the subwoofer. The dial can be rotated with a small flat blade screwdriver to select the desired number. If you change the **Home Code** you must turn the subwoofer off and on again to reset the **Home Code**. The cinema system and subwoofer must be on the same **Home Code** to communicate wirelessly.

Your Klipsch Controller

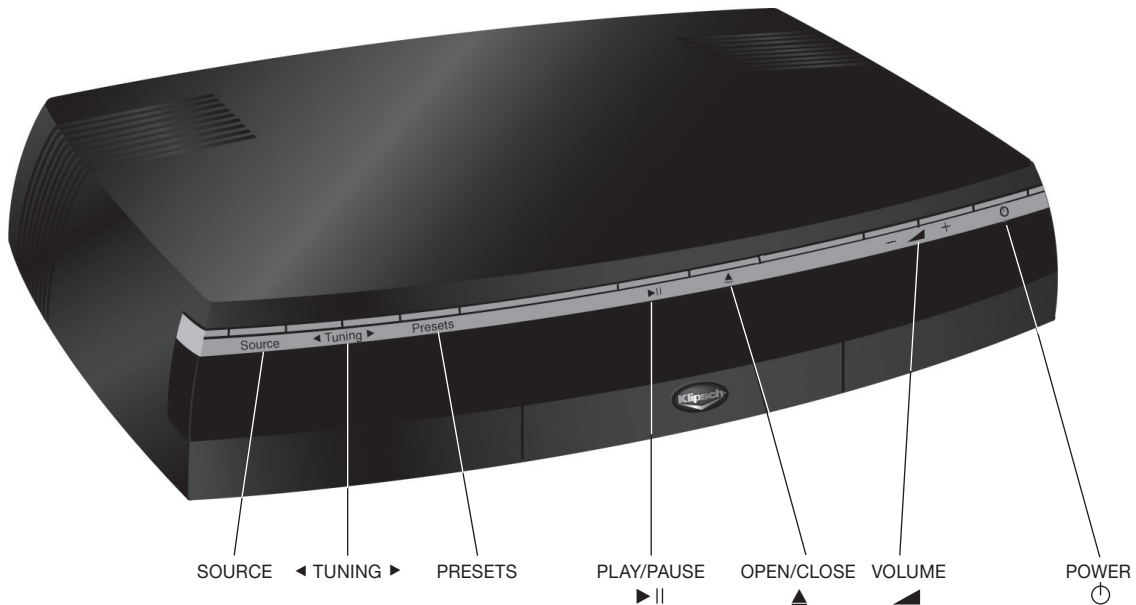

Buttons

SOURCE

Chooses the function you want to use—radio, DVD/CD, watch TV, access any other components connected to your Klipsch system (VCR, video game system, etc.). Each time you press the SOURCE button, it goes to the next “Input” that corresponds to the component that’s connected to that input jack on the back of your Klipsch system.

PRESETS

When listening to the radio, this button moves to the next radio station that you programmed into the preset memory.

▶|| PLAY/PAUSE

Plays discs in disc tray, and pauses playback when a disc is playing.

▲ OPEN/CLOSE

Opens and closes the disc tray.

⏻ POWER

Turns your Klipsch system on and off.

◀ VOLUME

Adjusts the volume.

◀ TUNING ▶

Changes radio station. Specific functionality of these buttons can be selected in the tuner setup menu.

Display

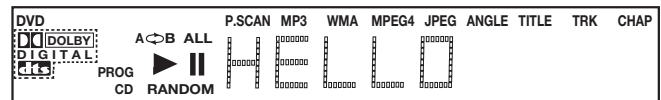

The display on the front of your Klipsch system provides playback information. The display illuminates each option that is active for the type of media you are playing. The numbers on the display let you know the track, title, and/or chapter number of the disc. Additionally, information from the radio’s RDS (Radio Data System), such as artist and track information, is displayed when you’ve tuned to the radio function. Below are explanations of display messages you may encounter that may not be covered in other parts of this manual.

Dolby® Digital

The trademarked marketing name for Dolby Laboratories’ AC-3 codec. The common version contains six total channels of sound, with five channels for normal-range speakers (Right Front, Center, Left Front, Right Rear and Left Rear) and one channel for the subwoofer. The Dolby Digital format also supports Mono and Stereo. Your Klipsch system supports Dolby Digital with its 2.1 audio system design.

DTS (Digital Theatre Systems)

A multi-channel surround sound format (rival of Dolby Digital). With DTS, the encoders and decoders support numerous channel combinations and stereo. DTS contains four-channel+LFE (Low Frequency Effects) audio tracks. Digital Theatre Systems was the name of the company that developed this format (currently referred to as DTS). Film director Steven Spielberg was one of the company’s initial investors. Spielberg films use the DTS audio format.

P.SCAN (Progressive Scan)

Lights if the P.SCAN switch on the back of the Klipsch system is in the ON position.

The Basics

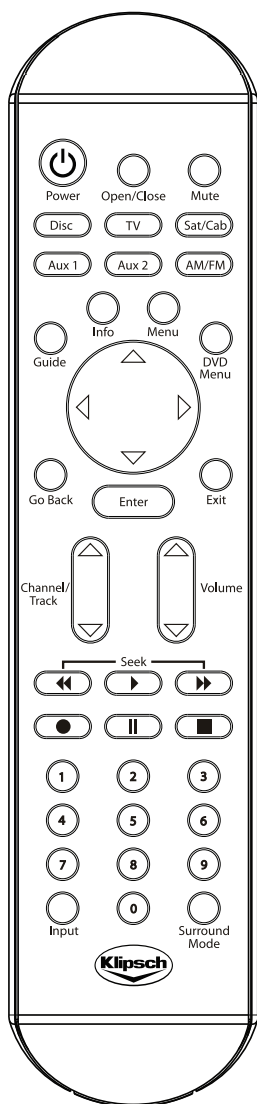

Switching between media—TV, DVD, Radio, CDs, etc.

Your Klipsch system is the center of your entertainment room...now, you just need to understand how to get from one type of entertainment to another. To move to a different type of media, press the corresponding button on the remote control (DISC, AM/FM, SAT/CAB) or keep pressing SOURCE on the front of your Klipsch system to access the different options.

When you turn on your Klipsch system, it tunes to the last source you used. The front panel indicates what source is active.

DISC	DVD or CD
AM/FM	Radio
SAT/CAB	Watching TV from a set-top box (cable, satellite, HD receiver)
AUX 1	Component connected to AUX 1 INPUT jacks (e.g., TV or VCR)
AUX 2	Component connected to the jacks on the side of the unit
TV	Watching TV without a set-top box connected

Progressive Scan TVs

On the back of your Klipsch CS-700 system, there is a progressive scan switch labeled **P.SCAN**. Progressive scan is a result of the digital TV transition—it is a process digital TVs can use to read and display broadcast signals. Progressive scan TVs display each pixel (picture element) of the signal consecutively line by line. All progressive scan TVs are digital, but not all digital TVs are progressive scan.

Some digital TVs only support the classic interlace display method that TVs have used since their inception. With interlace scanning, a TV draws every other line of the broadcast signal—first, the even numbered lines and then the odd numbered lines. This process happens so quickly it tricks your eye so it appears as though you're seeing the entire picture.



If your digital TV is progressive scan, turn the **P.SCAN** switch to **ON**. Additionally, you must use the **COMPONENT VIDEO** connection (Y, Pb, Pr) from the Klipsch system's **VIDEO OUTPUT** jacks to the progressive scan TV's **COMPONENT VIDEO** (Y, Pb, Pr) **INPUT** jacks in order for progressive scan to work correctly. See Step 4 on page 5 for detailed instructions.

NOTE: If you put the P.SCAN switch in the ON position and your TV doesn't support progressive scan, you won't see a picture on the TV screen.

CHAPTER 2: REMOTE CONTROL

The universal remote control that came packed with your Klipsch system can be programmed to operate the basic functions of many other brands of audio and video components, such as TVs, satellite receivers, cable boxes, DVD players, and others. The design of the remote control groups the buttons to help you achieve better performance from your remote. In this section of the manual, you will learn the function of each button and how to program it to operate other brands of components. To use the remote control effectively, always aim it directly at the Klipsch controller.

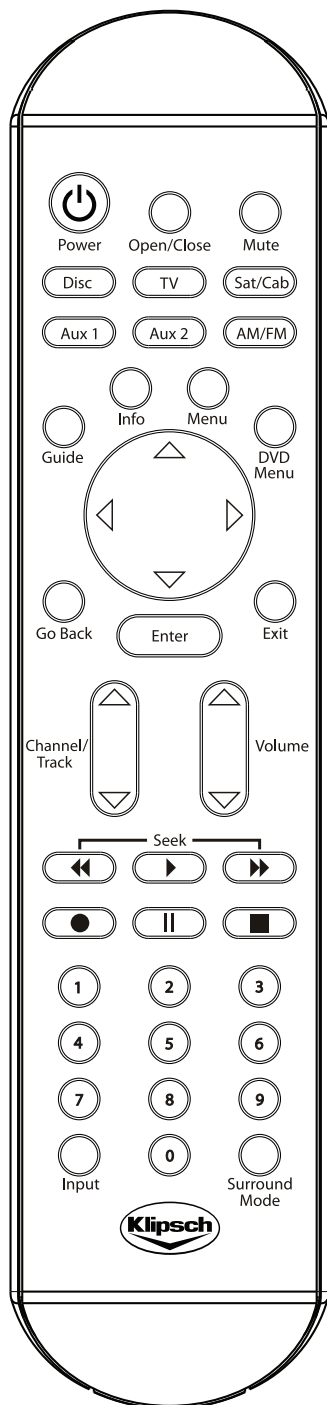

Buttons

Descriptions of the buttons are arranged alphabetically to help you locate the information quickly.

0-9 Use the number buttons for direct “channel” access in TV or SAT/CABLE mode. In addition, these numbers can be used to select or input information in the menus or information banners.

ARROW BUTTONS (△ ▽ ◀ ▶) Use the arrow buttons to highlight options and navigate through menu systems. The arrow buttons move the highlight in the corresponding direction of the arrow buttons.

AM/FM Selects the radio tuner and switches between AM and FM stations.

AUX 1 Switches the Klipsch unit to AUX 1. When the **AUX 1** button is programmed, it operates the basic functions of the component connected to the AUX 1 INPUT jacks.

AUX 2 Switches the Klipsch unit to AUX 2. When the **AUX 2** button is programmed, it operates the basic functions of the component connected to the AUX 2 INPUT (side panel) jacks.

CHANNEL/TRACK (Channel Up/Down) Selects the lower or higher station on the radio. If programmed properly, selects the lower or higher channel on a TV, satellite receiver, or cable system. Also skips tracks on CDs and chapters on DVDs.

DISC Places the remote in CD/DVD mode to operate the CD/DVD player.

DVD MENU Displays or removes the DVD disc’s menu.

ENTER Selects the highlighted option within a menu system.

EXIT Removes on-screen displays.

FORWARD (▶▶) Searches forward through a DVD, CD, mp3, and radio stations during playback (or video tape, recordable DVD, or camcorder if the remote is properly programmed).

GO BACK (◀◀) Returns to the previous menu in the menu system. When watching TV, satellite receiver or cable channels, tunes to the previous channel if the remote is programmed to operate those types of components.





GUIDE Displays the **DVD menu** when in DVD mode. During disc playback, displays the **title menu** if the disc has one and also removes the **title menu** and resumes playback. Displays the program guide in the TV or Satellite/Cable mode (if available) and if the remote is programmed to operate that component.

INFO Displays and removes the information banners for DVD, CD, and radio.

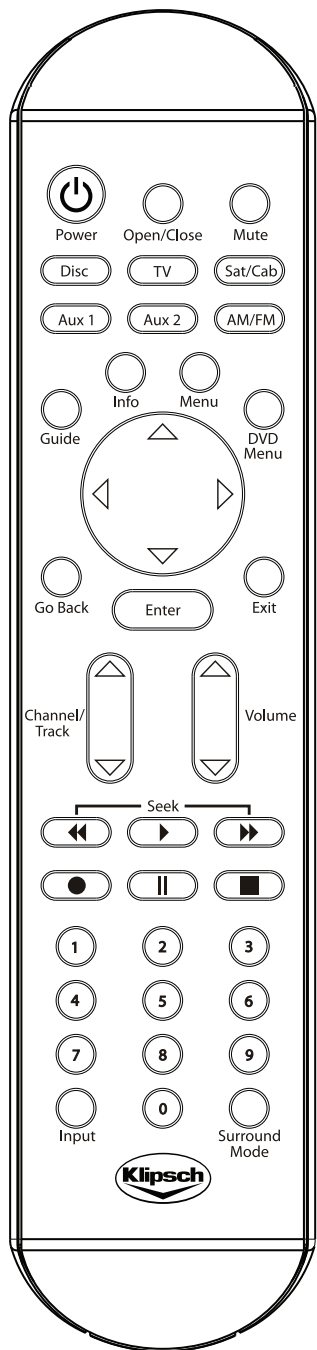
INPUT Accesses the individual input jacks on the Klipsch controller to see the signal of the component connected to the jacks.

MENU Displays the main menu of the selected component. In DISC or AM/FM mode, the **Klipsch menu** is displayed.



- MUTE** Reduces the audio to a minimum level. Press again to restore the volume.
- OPEN/CLOSE** Opens and closes the disc drawer.
- POWER** Turns the Klipsch controller on and off and tunes it to the last selected input. If the remote is programmed to operate other components, the **POWER** button is used together with the component buttons (**AUX 1**, **TV**, **AUX 2**, and **SAT/CAB**) to turn the components on and off.
- PLAY**  Begins playback of disc (or video tape if the remote is properly programmed to operate a VCR).
- PAUSE**  Temporarily stops disc play (or video recording/playback, recordable DVD or compatible camcorder, if the remote is properly programmed to operate those types of components).
- RECORD**  When the remote is properly programmed, records a program on a recordable component, such as VCR, DVR, or RDV.
- REVERSE**  Searches backward through a DVD, CD, mp3, and radio stations during playback (or video tape, recordable DVD, or camcorder if the remote is properly programmed).
- SAT/CAB** (SATELLITE RECEIVER/CABLE) Switches the Klipsch unit to SAT/CAB INPUTS. When the **SAT/CAB** button is programmed, it operates the basic functions of the component connected to the **SAT/CABLE/HD INPUT** jacks.
- STOP**  Stops playback.
- SURROUND MODE** Toggles between the **OFF**, **ON** or **WIDE** options in surround audio.
- TV** Selects the TV for which the button was programmed and operates the basic functions of that TV.
- VOLUME** (VOLUME UP/DOWN) Controls the audio level in every mode except when using the menu system. Also, restores volume when **MUTE** has been activated.

Programming Your Remote Control

Your remote control is a universal remote which means you can program it to operate other brands of electronic components, such as TVs, satellite receivers, cable boxes, VCRs, etc. Follow these steps to program your remote control.

1. Turn off the component to be programmed.
2. Look up the brand and code in the code list (located in the "More Information" section of this manual) or the "Remote Control" section of the on-screen menu system.
3. Press and hold the component button (**AUX 1**, **AUX 2**, **TV** or **SAT/CAB**) on the remote control for three (3) seconds, or until the LED goes out.
4. Release the component button and enter the first code for your brand and type of component.
5. If the code is accepted, the LED will flash 3 times.
6. Press the **POWER** button to see if the component turns on. If it doesn't, try another code from the list.

Remote Control Batteries

If the batteries are removed from the remote control after you have programmed the component buttons, you might need to reprogram the buttons. The remote memory is only maintained for a short period of time.

CHAPTER 3: OPERATION



Compatible Discs

- **DVDs**—DVD-R, DVD-RW, DVD+R, DVD+RW, and DVD-ROM.
- **CDs**—Audio CDs, CD-R, CD-RW, CD-ROM, and CDs that contain mp3 music files or JPEG (picture) files.
- **VCDs**—Video CDs contain video and audio, but hold less information than DVDs. VCDs are less common than DVDs. VCDs typically have lower quality video and audio than DVDs.
- **Super VCDs**—S-VCDs support MPEG-2 standard video and MPEG-1 audio. They typically hold about 70 minutes of content.

Incompatible Discs

The Klipsch system does not support laserdiscs, CD-I, CD-ROM (computer only discs), and discs recorded using other broadcast standards, such as PAL, SECAM, DVD-RAM discs or pirated discs.

Regional Coding

DVD Players and DVDs are coded by region. The region codes must match in order for the disc to play. The Klipsch system's DVD player is Region 1. You can only play Region 1 DVDs in this player.

Playing a disc

1. Press **DISC** on the remote to put the Klipsch system in DVD mode or toggle the **SOURCE** button on top of the unit.
2. If the TV didn't turn on and tune to the correct **VIDEO INPUT** channel (you will see the Klipsch DVD screen), turn on your TV and tune the TV to the channel that matches how you connected the Klipsch system output jacks to the TV's input jacks (see page 5 for additional information).
3. Press **OPEN/CLOSE** (the disc tray opens).
4. Place a disc into the tray with the label facing up (double-sided discs have content on both sides, so you can load the disc with either side up). The label that is facing up is the content that plays.
5. Press **OPEN/CLOSE** or **PLAY** (the disc tray closes and your Klipsch system reads the contents of the disc).
6. What happens next depends upon the type of disc you put in the player and how it was formatted.
7. If the disc doesn't start playing automatically, follow instructions on the screen or press **PLAY**.

DVD and VCD Playback Features

You can use the remote control to access various features during playback if the disc was formatted to support the features.

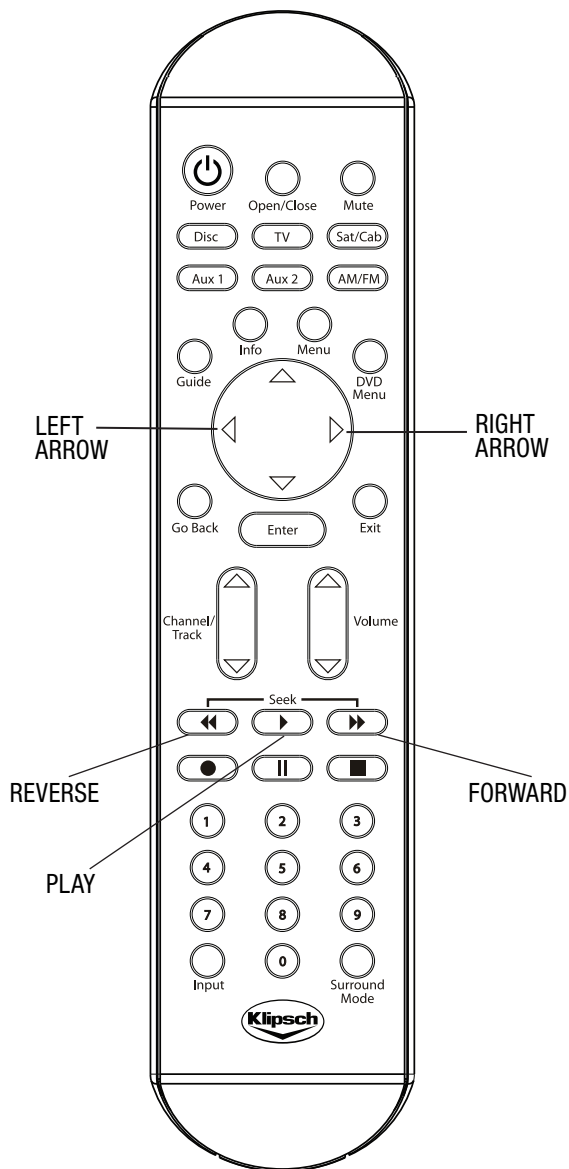

Transport

To move forward or backward on the disc, simply press **FORWARD** or **REVERSE** during playback. Each time you press **FORWARD** or **REVERSE**, the speed will increase until the maximum search speed is reached. To resume playback, press **PLAY**.

To advance through the disc's chapters during playback, press the **CHANNEL ▲** button (the Info Banner appears with the Chapter selection highlighted). The **CHANNEL ▼** button takes you to the previous chapter.

To skip forward 10 seconds, press the **RIGHT ARROW** button. For an instant replay, which will skip backward 10 seconds, press the **LEFT ARROW** button.

In addition to using the remote control, you can use the Playback Info Banner to access many playback features. See page 17 for more information.

Navigating Info Banners

Your Klipsch system is equipped with on-screen Info Banners that enable you to quickly access various playback features. The content of the banner changes depending upon the type of media you are playing, but the way you navigate the banners is the same.

- To access the Info Banner, press INFO while the disc is playing.
- To see the individual options of an info banner item, simply use the LEFT and RIGHT arrow buttons to highlight the option and press ENTER, or use the ▲ or ▼ arrows to select an option.
- There will be no Info Banners for mp3 or jpeg discs.

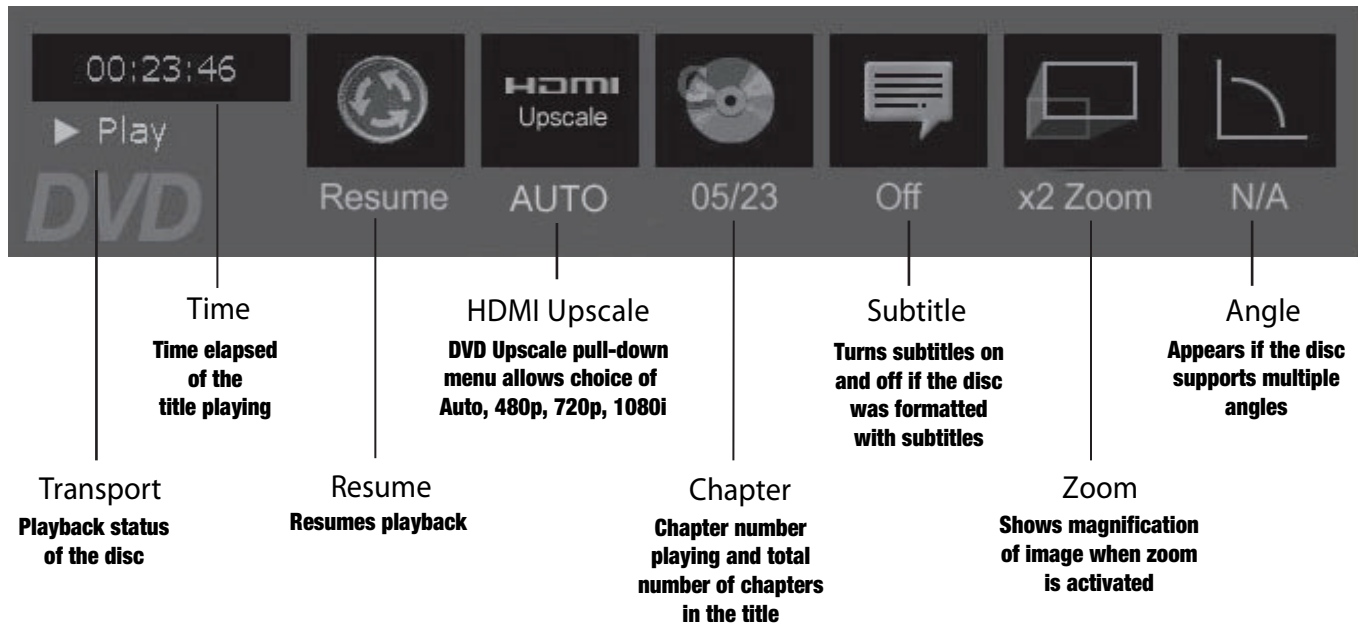

00:23:46

TIME DISPLAY: To use the time display as a search feature, highlight the icon and use the number buttons on the remote control to enter the time within the title you want to access and press ENTER. You must enter two digits for each field. For example, if you enter 0, 1, 2, 3, 1, 7 (01:23:17), playback will start one hour, 23 minutes, and 17 seconds into the title. Additionally, you can use the CHANNEL ▲ or the ▼ arrow button, CHANNEL ▲ or the ▼ arrow button to increase or decrease time one unit at time.



CHAPTER: To access another chapter within the title that is playing, use the number buttons on the remote control while the Chapter icon is highlighted. Additionally, you can use the CHANNEL ▲ or the ▲ arrow button to move forward a chapter at a time or CHANNEL ▼ or the ▼ arrow button to go backward a chapter at a time.



RESUME: To resume playback at the point where you paused playback, highlight the resume icon and press ENTER.



SUBTITLES (if available on disc): To change the subtitles or turn off, highlight the Subtitle icon and use the ▼ arrow button to select and change the subtitle.



HDMI Upscale: To upscale the DVD playback through HDMI, select the icon and use the CHANNEL ▼ or the ▼ arrow button to choose 480p, 720p, 1080i or AUTO DVD upscaling resolution and press ENTER. AUTO will upscale to your TV's default screen resolution, up to 1080i.



ZOOM: Shows the magnification chosen. To change, highlight the zoom icon and press ENTER.



ANGLE: If multiple angles are available for the title playing, this icon will indicate the number of angles and allow you to access other angles by pressing the ENTER button.

Playing CDs

You'll get maximum sound while playing audio CDs in your Klipsch system. To access playback features, press INFO on the remote control during playback (the Info Banner appears).

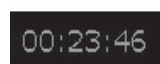
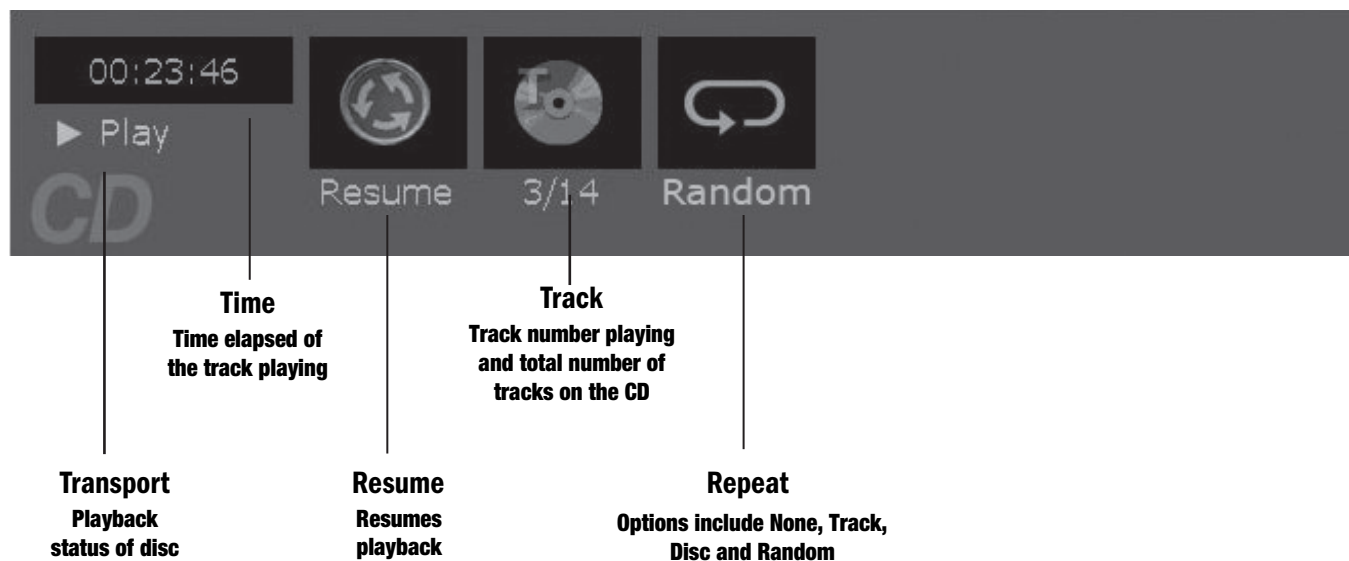

TIME DISPLAY: To use the time display as a search feature, highlight the icon and use the number buttons on the remote control to enter the time within the track you want to access, and press **ENTER**. You must enter two digits for each field. For example, if you enter 0, 0, 0, 1, 2, 3 (00:01:23), playback will start one minute and 23 seconds into the track. Additionally, you can use the **CHANNEL ▲** or **▼** button to increase or decrease time one second at a time.



RESUME: To resume playback at the point where you paused playback, highlight the resume icon and press **ENTER**.



TRACK: Shows the track playing and the total number of tracks on the CD. To access another track, you can use the number buttons on the remote control to enter the track number. Additionally, to move to the next track, you can press the **CHANNEL ▲** or the **▲** arrow button. To move to the previous track, press **CHANNEL ▼** or the **▼** arrow button.



REPEAT: If you want to repeat playback of a Track or the Disc, or play the tracks in random order press **ENTER** with the Repeat icon highlighted. Press the **▼** arrow button to highlight the repeat option you want to use and press **ENTER**. To turn off repeat, select None and press **ENTER**.

Playing CDs with mp3 or JPEG files

What you see on the TV screen when playing CDs with audio and picture files depends upon the way the discs were formatted and the file type used. Initially, the root menu will be displayed on the left side. Folders or files will be displayed on the right and can be selected. Highlight the desired folder or file from the right side and press ENTER. If a folder has been selected, its contents will be displayed in this area. If a file has been selected, it will play or be displayed on the screen. To navigate back up a level, select the root menu from the right side. ▲ and ▼ arrows keys are used to navigate through the list. If the disc doesn't play, consult the application you used to create the disc.

Playing the Radio

When you are in the Tuner Mode, the remote control can be used to tune radio stations. Use the FORWARD and REVERSE or the CHANNEL ▲ or ▼ button to change the frequency.

Setting up presets:

1. Tune to the station you would like. Press and hold the PRESET button for approximately three seconds and release. You will see a number that signals the next available preset on the display. Press the PRESET button again to stop the flashing and store the station.
2. To change a preset you already have, tune to the preset station you want to change and follow step 1.
3. There are twenty presets –10 FM and 10 AM.

On-screen info banner

To access the radio info banner, press INFO on the remote control.

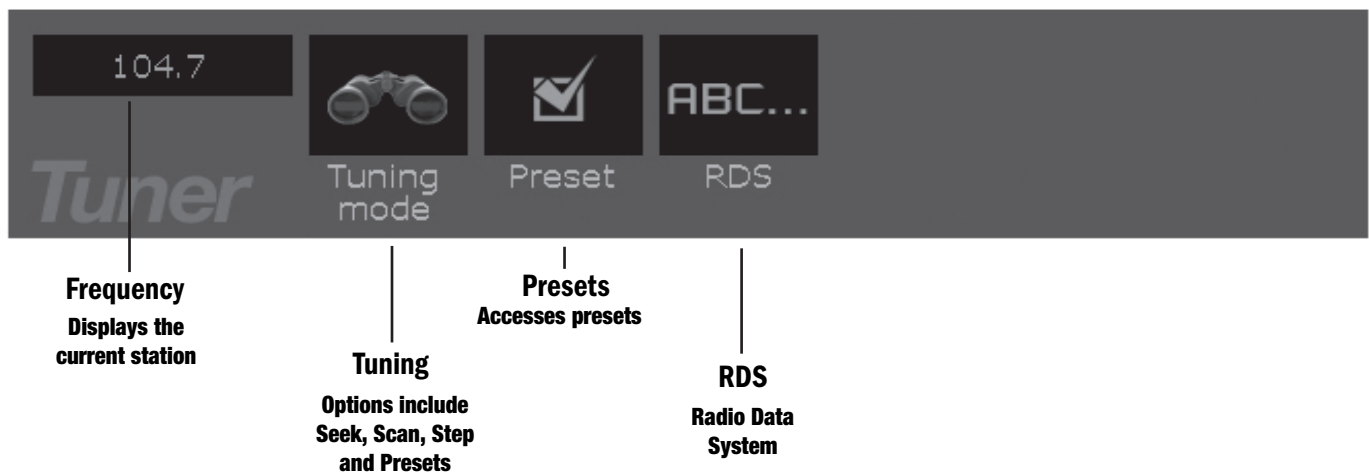

TUNING MODE: To access different ways to tune to various radio stations, press ENTER with the Tuning icon highlighted (the tuning options appear). Use the ▼ arrow button to highlight the option you want to use and press ENTER.

SEEK: Goes to the next available station and stays tuned to it.

SCAN: Previews stations throughout the frequency—plays for several seconds and then moves to the next station. To tune to a station during scan, press ENTER while it is playing.

STEP: Moves incrementally one frequency step at a time.



PRESETS: Shows you the station number for each of the presets available. Highlight the icon and press ENTER or ▼ arrow to see list and select.



RDS: RDS stands for Radio Data System and enables broadcasters to embed information in the signal. You can choose to turn this feature on or off. Highlight this icon and press ENTER or press the down ▼ arrow to see list.

CHAPTER 4: MENU SYSTEM

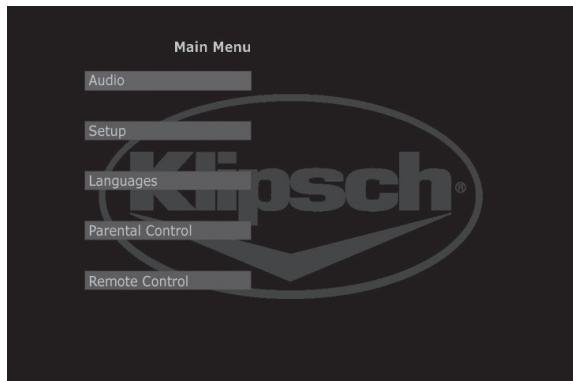

On-Screen Menu System

Your Klipsch CS-700 System contains on-screen menus that let you personalize settings to get the most out of your home theater experience.

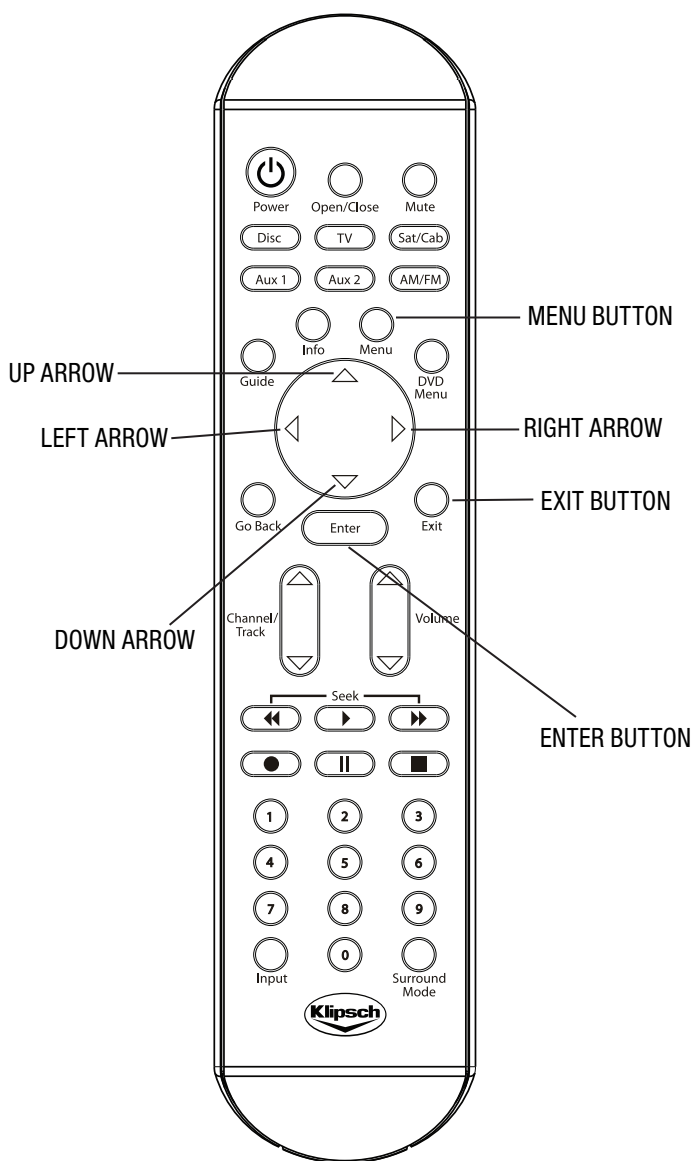

Navigating Menus

To access the menu system, press MENU (the main menu appears).

Use the arrow buttons to move the direction you want to go. You'll notice the menu is highlighted to let you know where you are.

When a menu item is highlighted, press ENTER to see the submenus or to activate the option that is highlighted.

On-Screen Menus

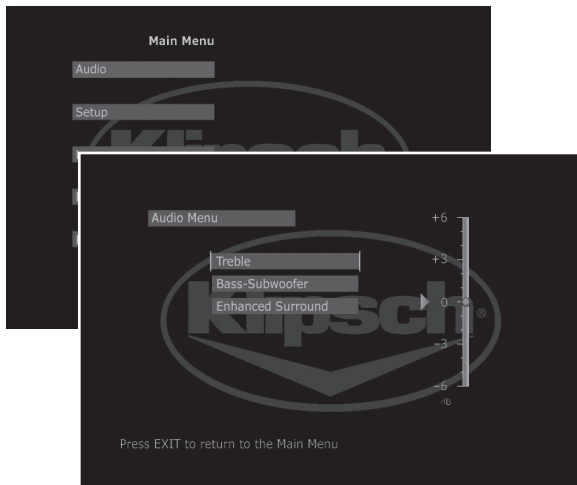

Audio

Treble: Use the ▲ and ▼ arrow buttons to increase or decrease the amount of high frequency sound.

Bass-Subwoofer: Use the ▲ and ▼ arrow buttons to increase or decrease the amount of low frequency sound.

Enhanced Surround: Choose the setting that is most desirable to you. Use the arrow button to highlight **ON**, **OFF** or **WIDE** and press ENTER.

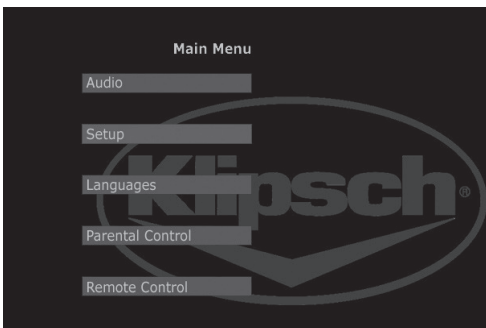

Setup

The **Setup** menu is described in Chapter 1. If you add components to your system or change how they are connected, you may need to access the **Setup** menu to tell your Klipsch system what is where and how it is connected. Go to page 9 for detailed instructions.

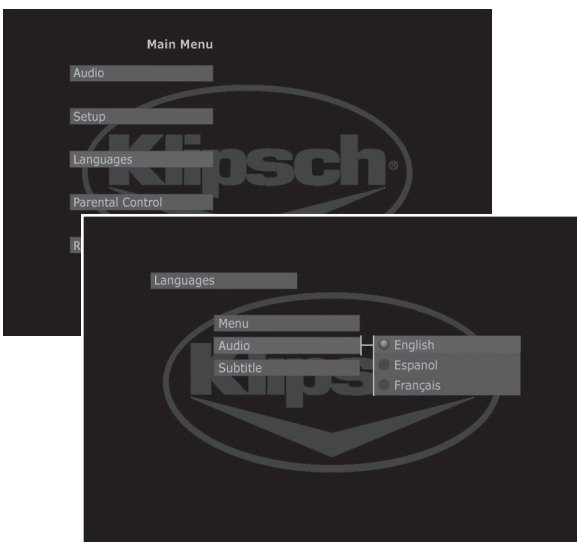

Languages

Menu: Choose the language of the on-screen menus.

Audio: For DVDs, you can choose your primary language. If the DVD was formatted with that language, the DVD will play in the language you select. The default is English.

Subtitle: For DVDs, you can change the language setting for subtitles. If the DVD was formatted with subtitles in the language chosen in this menu, the subtitles will appear in that language. Turn on subtitles via the Info Banner during playback (page 17).

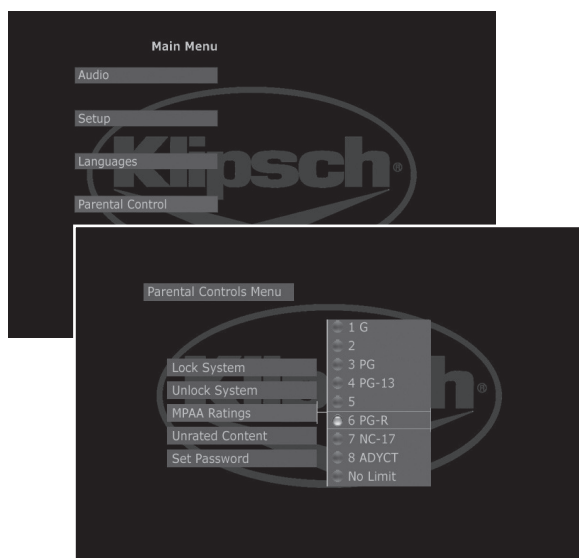

Parental Control

The **Parental Control** menu lets you password-protect DVDs by using the MPAA (Motion Pictures Association of America) rating system to tell the Klipsch system which ratings require a password in order to play the DVD.

Lock System/Unlock System: Locking the system puts the ratings limit you have selected into effect. Use the digits buttons to enter a four-digit password.

MPAA Ratings: Use the ▲ and ▼ arrow buttons on the remote to select to the highest rating you find acceptable. Press ENTER.

Unrated Content: Some discs contain movies that don't have a rating assigned to them. Sometimes, movies you might find the most explicit are unrated. Also, much of the new content on DVDs, such as director's cuts, interviews with actors, etc., is unrated. In this menu, tell the Klipsch system how you want unrated content to be handled. Choose **Lock Unrated Content** if you want unrated content to be password protected.

Set Password: Use the number buttons on the remote control to enter the password that will be required for DVD content that is rated above the level you have set as acceptable in the **MPAA Ratings** menu.

Note: It's a good idea to write down your password and keep it in a safe place.

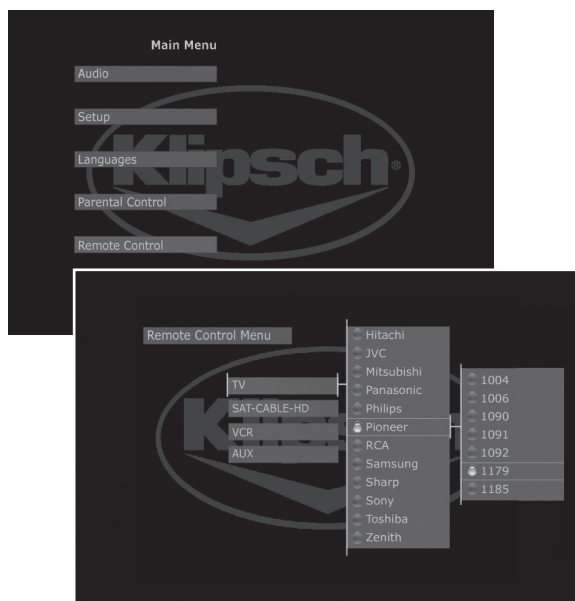

Remote Control

The easiest way to control your home theater experience is to take the time to program the remote control to operate your TV, set-top box or any other components you have connected to your Klipsch system. Instructions for programming the remote control are in Chapter 2. To program the remote control, you have to find the code that matches the component you have. The codes are in Chapter 6, but are also provided in this menu.

TV: In order for your Klipsch remote control to operate your TV, follow the instructions in Chapter 2. To enter the code for your TV, access the **Remote Control** menu. With **TV** highlighted, press ENTER.

SAT-CABLE-HD: This menu has codes for satellite receivers, cable boxes, and HD receivers. Use the codes in this menu to program your remote control to operate the type of set-top box you connected to your Klipsch system.

AUX 1: Use codes to program the remote control to operate a connected component, preferably the component you have connected to the AUX 1 jacks on the back of your Klipsch system.

AUX 2: Use codes to program the remote control to operate a connected component, preferably the component you have connected to the AUX 2 jacks on the side of your Klipsch system.

CHAPTER 5: TROUBLESHOOTING

Trying to find the solution to a problem with your equipment can be very frustrating. The symptoms and solutions in this section will hopefully assist you in finding the correct answers. If you have additional questions that this manual cannot answer, please contact your nearest Klipsch dealer or call 1-800-KLIPSCH.

General problems

- No power—make sure you use an outlet that is not controlled by a wall switch.
- No power—make sure you've plugged the unit into a working outlet or the power strip is turned on.
- Menu is displayed in a foreign language—check **Languages** in the menu system to make sure the language that you want is selected.
- Screen saver appears on TV—press any button to remove the screen saver from the TV screen.
- Disc tray doesn't open—try unplugging the power cord and plugging it back in. Press and hold **STOP** for approximately 3 seconds to open the tray.
- Disc won't eject—disc cannot be ejected when the player is reading the disc. Wait a few seconds before ejecting the disc.

Video problems

- Make sure the TV and Klipsch system are turned on.
- Make sure the Klipsch system is in DVD mode (press **DISC** on the remote control).
- Make sure the TV is tuned to the VIDEO INPUT Channel that matches the input jack(s) you used to connect the TV to the Klipsch system (see page 5).
- Make sure the cables are attached securely (check your connections on page 5). You must connect Klipsch output jacks to a set of the TV's input jacks.
- Check the **P.SCAN** switch on the back of the Klipsch system. Make sure it is in the **OFF** position unless you are certain your TV supports progressive scan. The components must be connected via the Y, Pb, Pr jacks to use **P.SCAN**. See page 12 for additional information.
- Check the settings in the **Parental Control** menu.
- HI DEF COMPONENT VIDEO INPUT Y, Pb, Pr must have a corresponding HI DEF COMPONENT VIDEO OUTPUT.
- Digital HDMI COMPONENT VIDEO INPUT must have a corresponding Digital HDMI COMPONENT VIDEO OUTPUT.

Audio problems

- Make sure the cables are attached correctly, and that you've connected the appropriate cable to the appropriate jack (see page 28 for information about different audio options).
- Refer to your TV's owner manual to find out the procedures to set up your TV for a home theater system. With most TVs, you'll need to turn off the TV's internal speakers via the TV menu or a switch on the back of the TV. Additionally, you may need to change the Fixed or Variable setting.
- Check the settings in the Klipsch system's **Setup** menu, specifically the **TV Audio Connection** submenu. Make sure your selection matches the Klipsch system input jack you used to connect the audio originating from the TV or set-top box.

- If there is noise when the TV is turned on, the speakers may be too close to the audio system. See page 6 for more information.
- Make sure the **MUTE** button on the remote control has not been activated.
- Make sure the disc is not bad, damaged or dirty.
- Check the speaker cable connections.
- Check the options selected in the **Audio** menu.

Remote Control problems

- Make sure you have selected the correct component button placing the remote in that mode to operate the component.
- Check batteries and replace them if they are weak.
- Make sure batteries are inserted correctly with the polarities matching.
- If you programmed your remote to operate a specific component, you might need to re-program it.
- Make sure there are no obstructions between the remote and the component you're trying to operate.

Playback problems

- If the disc isn't playing, make sure the type of disc matches those listed in Chapter 3. If you're trying to play a DVD, make sure it is inserted with the label side up and it is coded for Region 1.
- If the disc starts to play, but stops immediately, you might need to clean the disc or check for condensation in the player. If condensation has formed in the player, allow it to dry.
- If the picture is distorted, fuzzy or jumps, try another disc as the disc might be damaged.

Radio problems

- If the incoming signal is weak, distorted, or noisy, you might need to connect an outside FM antenna or change the direction of the antenna.

General Wireless problems

- Make sure you have the wireless turned **ON** in the **Wireless menu** (within the setup menu).
- Make sure all KlipschCast components are set to the same home code number.

If your wireless broadcast to other KlipschCast component (other than the subwoofer) is interrupted for long periods of time or has static:

- You may have moved the KlipschCast component beyond its extended range. Try locating it closer to the CS-700 system.
- Check to make sure you have the proper source selected.
- The CS-700 system can only decode one digital multi channel signal at a time. You cannot decode one digital signal for local viewing/listening and a second for wireless transmission. Wireless transmission occurs in two-channel mode therefore it is recommended that you change the audio output of the source you wish to transmit to analog (R/L) stereo. This will allow you to use the decoder in the CS-700 for the locally viewed/heard source and wirelessly distribute the second signal to all KlipschCast listeners.

CHAPTER 6: CARE AND MAINTENANCE

Klipsch System

- If your unit has been stored in a cool place for any length of time, during a journey for example, wait for about 2 hours before using it.
- Keep the equipment away from sources of heat, such as a stove or radiator.
- Avoid blocking the ventilation openings on the unit to prevent overheating.
- This unit is designed for continuous use. Switching off the unit places it in standby mode, but does not disconnect it from the outlet power.
- If you notice any burning or smoke, disconnect the unit immediately to avoid any damage to you, the house, and/or the unit.
- If an object or liquid enters the unit, unplug it immediately and have it checked by an authorized dealer.
- Do not attempt to look inside the unit through the disc tray opening or any other opening. Invisible laser radiation when open. Avoid exposure to beam. Class 1 laser product. This system must be opened only by qualified technicians to prevent accidents caused by the laser beam.
- This unit is for domestic use only and must not be used for industrial purposes.
- Total or partial copying of recordings protected by copyright legislation, without the explicit permission of the holder of the rights, contravenes current legislation.
- Copying or downloading music files for sale or any other business purpose constitutes or could constitute a violation of copyright law.

Cleaning

- Use a soft, dry, clean cloth when cleaning the unit. Regularly dust all vents.
- Do not use solvents, abrasive or alcohol-based products when cleaning your system as it might damage the unit.

Handling and Caring for Discs

- Handle your discs with care. DO NOT touch a disc's surface. Hold it by the edge, or by one edge and the center hole.
- Use a soft clean cloth to wipe a disc. Wipe from the inner edge toward the outer edge. DO NOT WIPE IN A CIRCULAR MOTION.
- Insert the disc with the label facing up (for a single-sided disc).
- Place the disc properly into the tray. Never place two discs or more in the tray.
- Always keep discs in their cases and store the cases vertically.
- DO NOT store discs in direct sunlight or locations with high temperatures or high humidity, or extremely low temperatures.
- DO NOT write on a disc or put labels or tape on the label surfaces.
- DO NOT scratch discs.
- DO NOT move the unit when a disc is being played.
- DO NOT use record cleaning sprays, anti-static liquids, benzene thinner, or other solvents for cleaning discs. They can damage the disc surface.

Remote Control Code Lists

TV (TV / AUX 1 / AUX 2 Buttons)		Hitachi.....0003, 0005, 0007, 0039, 0042, 0053, 0073, 0115, 0135		Quasar0002, 0013		TV Code	DVD Code
Acer.....0124	HP.....0092, 0116, 0123	Radio Shack.....0011, 0023, 0025	Cytron.....0141.....2096				
Admiral.....0001, 0024, 0026	ILO.....0079, 0106, 0111, 0112, 0138	Radio Shack/Realistic...0000, 0003, 0005, 0007	Ilo.....0138.....2087				
Adventura.....0020	IMA.....0009, 0011, 0019, 0025, 01150009, 0011, 0019, 0025, 01150144.....2099				
Aiko.....0008	Infinity.....0014	RCA.....0000, 0002, 0003, 0004, 0005, 0034,0044, 0045, 0054, 0059, 0070, 0115,0154, 0165	Initial.....0138.....2087				
Aiwa.....0145	InFocus.....01360044, 0045, 0054, 0059, 0070, 0115,0154, 01650144.....2099				
Akai.....0023, 0074, 0137, 0143	Initial.....0138, 0144	Realistic.....0011, 0023, 0025	LG.....0162.....2104				
Alleron.....0010	Insignia.....0065, 0066, 0067, 0069, 0113	Runco.....0018, 0023, 0033	Magnavox.....0138.....2087				
American Action.....0025	Inteq.....0033	Sampo.....0003, 0005, 0019, 0023, 0077,0104, 0115, 01250144.....2099				
Amtron.....0009, 0025	Janeil.....0020	Samsung.....0003, 0004, 0005, 0007, 0016,0019, 0023, 0031, 0070, 0074, 0088,0115, 0120, 0149	Mintek.....0138.....2087				
Anam.....0025	JBL.....00140003, 0004, 0005, 0007, 0016,0019, 0023, 0031, 0070, 0074, 0088,0115, 0120, 0149	Panasonic.....0166.....2109				
Anam National.....0002, 0009, 0025	JC Penney.....0000, 0003, 0004, 0005, 0012,0013, 0016, 0019, 0070, 0115	Sansui.....0026, 0056, 0137	Polaroid.....0163.....2105				
AOC.....0003, 0004, 0005, 0023,0070, 0097, 0103, 0115	Jensen.....0003, 0005, 0115	Sanyo.....0003, 0011, 0100, 0115	Philips.....0138.....2087				
Apex.....0047, 0142	JVC.....0007, 0013, 0061, 0089	Scotch.....00050144.....2099				
Astar.....0108	Kawasho.....0003, 0005, 0115	Scott.....0003, 0005, 0007, 0009, 0010, 0025	RCA.....0165.....2108				
Audiovox.....0009, 0025, 0160	KEC.....0025	Sears.....0000, 0003, 0005, 0010, 0011,0078, 0115	Sansui.....0137.....2093				
Bang & Olufsen.....0139	Kenwood.....0003, 0005, 0023, 0115	Sharp.....0003, 0005, 0007, 0019, 0024,0035, 0082, 0083, 0085, 0086, 0115, 0150	Sony.....0164.....2106				
Bell & Howell.....0001, 0011	Kloss Novabeam.....0009, 0020, 0025	Sheng Chia.....0024	Toshiba.....0137.....2093				
Benq.....0064, 0124	KTV.....0009, 0019, 0023, 0025, 0031	Shogun.....0003, 01150140.....2095				
Bradford.....0009, 0025	LG.....0004, 0070, 0162	Signature.....0001					
Brilliant.....0028, 0078	Loewe.....0014	Sony.....0041, 0046, 0048, 0050, 0051, 0075,0080, 0130, 0134, 0156, 0157, 0158, 0164					
Brockwood.....0003, 0115	Logik.....0001	Soundesign.....0003, 0005, 0009, 0010,0025, 0115					
Broksonic.....0025, 0026, 0137	Luxman.....0003, 0005, 0115	SSS.....0003, 0009, 0025, 0115					
Candle.....0003, 0005, 0020, 0023, 0115	LXI.....0000, 0005, 0011, 0014	Starlite.....0009, 0025					
Carnivale.....0023	Magnavox.....0003, 0005, 0014, 0023, 0055,0081, 0102, 0115, 0138, 0144, 0146, 0155	Superscan.....0024, 0109, 0146					
CCE.....0031	Majestic.....0001	Supre-Macy.....0020					
Centurion.....0006	Marantz.....0003, 0005, 0014, 0023,0115, 0128	SVA.....0127					
Citizen.....0003, 0005, 0008, 0009, 0016,0019, 0023, 0025, 0115	Maxent.....0104, 0110	Sylvania.....0003, 0005, 0014, 0023, 0115					
Clarion.....0025	Megatron.....0005, 00530003, 0005, 0014, 0023, 0115					
Coby.....0161	Memorex.....0001, 0004, 0005, 0011,0026, 0070	Symphonic.....0009, 0025, 0060					
Colortyme.....0003, 0005, 0115	MGA.....0003, 0004, 0005, 0023, 0070, 0115	Syntax.....0030, 0091					
Concerto.....0003, 0005, 0115	Midland.....0013, 0018, 0019, 0033	Syntax-Brilliant.....0078, 0091					
Contec.....0025	Mintek.....0138, 0144	Tandy.....0024					
Contec/Cony.....0007, 0009, 0025	Minutz.....0012	Tatung.....0002, 0027, 0105					
Craig.....0009, 0025	Mitsubishi.....0003, 0004, 0005, 0024, 0062,0070, 0115, 0132, 0159	Technics.....0013					
Crown.....0009, 0014, 0025	Montgomery Ward.....0001	Techwood.....0003, 0005, 0013, 0115					
CTX.....0063	Motorola.....0002, 0024	Teknika.....0001, 0003, 0004, 0005, 0007, 0008,0009, 0010, 0016, 0019, 0025, 0070, 0115					
Curtis Mathes.....0000, 0003, 0005, 0011, 0016,0019, 0023, 0024, 0053, 0115	MTC.....0003, 0004, 0005, 0016, 0023,0070, 0115	Telecaption.....0017					
CXC.....0009, 0025	Multitech.....0009, 0025, 0031	TMK.....0003, 0005, 0115					
Cytron.....0141	Multivision.....0015	TNCi.....0033					
Daewoo.....0003, 0004, 0005, 0008,0019, 0049, 0070, 0115	NAD.....0005	Toshiba.....0011, 0016, 0017, 0131, 0133,0137, 0140, 0147, 0151					
Daytron.....0003, 0005, 00019, 0115	NEC.....0002, 0003, 0004, 0005, 0023, 0070,0096, 0115	Totevision.....0019					
Dell.....0098, 0102	Net-TV.....0104, 0105	Trutech.....0009					
Denon.....0053	Nikko.....0005, 0008, 0023	TVS.....0026					
DiamondVision.....0068, 0148	Norcent.....0097	Universal.....0012					
Dimensia.....0000	NTC.....0008	V Inc.....0093					
Dumont.....0003, 0018, 0033, 0115	Olevia.....0091, 0094	Vector Research.....0023					
Durabrand.....0022, 0025, 0026	Onwa.....0009, 0025	Vidtech.....0003, 0004, 0005, 0070, 0115					
Dwin.....0024	Optoma.....0021	Viewsonic.....0093, 0104, 0118, 0122, 0125					
Electrograph.....0104	Optonica.....0024	Viking.....0020					
Electrohome.....0002, 0003, 0005, 0115	Orion.....0026	Viore.....0106					
Emerson.....0003, 0005, 0007, 0009, 0010, 0011,0019, 0025, 0026, 0049, 0115, 0146	Panasonic.....0002, 0013, 0014, 0037, 0040,0057, 0071, 0087, 0119, 0166	Vizio.....0027, 0093, 0115, 0129					
Emprex.....0114	Penny.....0023	Wards.....0000, 0001, 0003, 0004, 0005, 0010,0012, 0014, 0023, 0070, 0115					
Envision.....0003, 0005, 0023, 0115	Philco.....0002, 0003, 0004, 0005, 0007, 0014,0023, 0070, 0115	Westinghouse.....0084, 0093					
Epson.....0095	Philips.....0002, 0003, 0007, 0014, 0043, 0052,0090, 0115, 0138, 0144, 0155	White Westinghouse.....0026, 0049					
ESA.....0074	Philips Magnavox.....0043, 0055	Yamaha.....0003, 0004, 0005, 0023, 0070, 0115					
Fisher.....0011	Pilot.....0003, 0019, 0023, 0115	Zenith.....0001, 0003, 0018, 0026, 0033,0036, 0115					
Fujitsu.....0010	Pioneer.....0003, 0005, 0072, 0076, 0115						
Funai.....0009, 0010, 0025	Plasm SYNC.....0126, 0128						
Futurtech.....0009, 0025	Polaroid.....0029, 0117, 0163						
Gateway.....0027, 0104, 0125	Portland.....0003, 0004, 0005, 0008, 0019,0070, 0115						
GE.....0000, 0002, 0003, 0005, 0012,0013, 0038, 0115, 0152	Price Club.....0016						
Gibraltar.....0003, 0018, 0023, 0033, 0115	Prism.....0013						
Goldstar.....0003, 0004, 0005, 0007,0019, 0023, 0070, 0115	Proscan.....0000, 0058						
Grumpy.....0009, 0010, 0025	Proton.....0003, 0005, 0007, 0115						
Haier.....0022	Proview.....0029						
Hallmark.....0003, 0005, 0115	Pulsar.....0003, 0018, 0033, 0115						
Harvard.....0009, 0025							
Havermy.....0024							
Hewlett Packard.....0092, 0121, 0123							
Hisense.....0032, 0101							

TV/VCR Combo (TV / AUX 1 / AUX 2 Buttons)

TV Code	VCR Code
GE.....0152.....1053	
Magnavox.....0155.....1056	
Philips.....0155.....1056	
RCA.....0154.....1055	
Samsung.....0149.....1050	
Sharp.....0150.....1051	
Sony.....0156.....1057	
Sylvania.....0153.....1054	
Toshiba.....0151.....1052	

TV/DVD/VCR Combo (TV / AUX 1 / AUX 2 Buttons)

TV Code	DVD Code	VCR Code
DiamondVision..0148.....	2102.....	1049
Emerson.....0146.....	2100.....	1047
Magnavox.....0146.....	2100.....	1047
Superscan.....0146.....	2100.....	1047
Sylvania.....0146.....	2100.....	1047
Toshiba.....0147.....	2101.....	1048

VCR (AUX 1 / AUX 2 Buttons)

Adventura.....1007
Aiwa.....1007
Akai.....1001, 1011
American High.....1006
Apex.....1040
Asha.....1004
Audio Dynamics.....1002
Audiovox.....1005
Bang & Olufsen.....1013
Beaumarck.....1004
Bell & Howell.....1003
Broksonic.....1036, 1038
Calix.....1005
Candle.....1004, 1005
Canon.....1006
Citizen.....1004, 1005
Colortyme.....1002
Craig.....1004, 1005
Curtis Mathes.....1000, 1002, 1004, 1006
Cybernex.....1004
Daewoo.....1007
DBX.....1002
DiamondVision.....1049
Dimensia.....1000
Dynatech.....1007
Electrohome.....1005
Electrohome.....1005
Emerson.....1005, 1006, 1007, 1039, 1047
ESA.....1023
Fisher.....1003
Fuji.....1001, 1006
Funai.....1007, 1015, 1039
Garrard.....1007
GE.....1000, 1004, 1006, 1053
Goldstar.....1002, 1005
Gradiente.....1007

TV/DVD Combo (TV / AUX 1 / AUX 2 Buttons)

TV Code	DVD Code
Akai.....0137.....2093	
.....0143.....2098	
Apex.....0142.....2097	
Audiovox.....0160.....2103	
Bang & Olufsen.....0139.....2094	
Broksonic.....0137.....2093	
Coby.....0161.....2107	

Remote Control Code Lists (continued)

Harley Davidson	1007	TMK	1004	NEC	4002	Motorola	3007, 3018, 3061		
Harman/Kardon	1002	Toshiba	1008, 1027, 1042, 1048, 1052	NET Brazil	4042	Next Level	3007		
Headquarter	1003	Totevision	1004, 1005	NSC	4015	Panasonic	3013, 3042		
Hitachi	1008, 1009, 1011	Unitech	1004	Oak	4009	Pansat	3045		
Insignia	1033, 1046	Vector Research	1002	Pace	4026	Paysat	3006		
Instant Replay	1006	Video Concepts	1002	Panasonic	4019, 4021, 4023	Philips	3005, 3006, 3008, 3015, 3017, 3034, 3054, 3063, 3067		
JC Penney	1002, 1003, 1004, 1005, 1006, 1008, 1009	Videosonic	1004	Paragon	4023	Proscan	3014, 3036, 3059		
JCL	1006	Wards	1004, 1005, 1006, 1007, 1008, 1009	Philips	4007, 4008, 4014	Proton	3011		
Jensen	1008, 1009, 1011	White Westinghouse	1015	Pioneer	4016, 4017, 4025, 4033, 4045	Radio Shack	3007		
JVC	1002, 1003, 1011, 1028, 1029, 1030, 1031	XR-1000	1006, 1007	Popular Mechanics	4028	RCA	3001, 3009, 3014, 3028, 3029, 3030, 3031, 3033, 3035, 3057, 3063, 3064		
Kenwood	1002, 1003, 1011	Yamaha	1002, 1003, 1011	Proscan	4000	Realistic	3002		
Kodak	1005, 1006	Zenith	1001, 1012, 1021, 1033	Pulsar	4023	Samsung	3008, 3021, 3038, 3041, 3063		
LG	1005, 1033, 1034, 1035	DVD/VCR Combo		Quasar	4023	Sharp	3049		
Lloyd's	1007	(AUX 1 / AUX 2 Buttons)		Radio Shack	4024, 4030	Sony	3019, 3026, 3032, 3039, 3040, 3055, 3065, 3066		
LXI	1005	DVD Code	VCR Code	RCA	4004, 4021	Star Choice	3007, 3024, 3061		
Magnavox	1006, 1020, 1047, 1056	Apex	2088..... 1040	Realistic	4006	STS	3004		
Magnin	1005	Broksonic	2083..... 1036	Recoton	4028	Tivo	3008, 3063		
Marantz	1002, 1003, 1006 2086..... 1038	Insignia	Regal	4013	Toshiba	3015, 3017, 3043		
Marta	1005 2081..... 1033 2085..... 1033	Regency	4010	UltimateTV	3009		
Matsushita	1006	JVC	2076..... 1028	Rembrandt	4000	Uniden	3006		
MEI	1006 2077..... 1029 2078..... 1030	Runco	4023	US Digital	3011		
Memorex	1003, 1004, 1005, 1006, 1007, 1014, 1022, 1038 2079..... 1031 2079..... 1031	Samsung	4017, 4025	USDTV	3011		
MGN Technology	1004	LG	2081..... 1033	Scientific Atlanta	4003, 4033, 4037, 4041, 4045, 4047, 4049, 4050, 4051	Viewsat	3046		
Minolta	1008, 1009 2082..... 1034 2082..... 1034	Signal	4011, 4024	Voom	3007		
Mitsubishi	1008, 1009, 1019 2081..... 1035 2081..... 1035	Signature	4000	Zenith	3020, 3068		
Motorola	1006	Memorex	2086..... 1038	Sony	4032, 4038	DVR/PVR			
MTC	1004	Polaroid	2088..... 1040	Sprucer	4021	(SAT-CAB / AUX 1 / AUX 2 Buttons)			
Multitech	1004, 1007	Samsung	2080..... 1032	Standard Component	4018	ABS	5016		
NEC	1002, 1003, 1011	Sansui	2086..... 1038	Starcom	4011, 4022, 4024	Alienware	5016		
Nikko	1005	Sanyo	2092..... 1045	Stargate	4011, 4024	Bang & Olufsen	5022		
Noblex	1004	Sharp	2084..... 1037	Starquest	4011, 4024	CyberPower	5016		
Olympus	1006	Sony	2072..... 1024	Supercable	4027, 4046	Dell	5016		
Optimus	1005 2073..... 1025 2073..... 1025	Supermax	4030	DIRECTV	5000, 5001, 5003, 5004, 5005, 5006, 5007, 5010, 5015, 5017, 5023		
Orion	1014 2074..... 1026 2074..... 1026	TIME WARNER	4040	Dish Network	5013, 5014		
Panasonic	1006, 1017 2074..... 1026 2074..... 1026	Tocom	4001	Dishpro	5013		
Pentax	1008, 1009 2089..... 1041 2089..... 1041	Toshiba	4023	Echostar	5013, 5014		
Philco	1006 2091..... 1043 2091..... 1043	Tristar	4030	Expressvu	5013		
Philips	1006, 1020, 1039, 1056	Toshiba	2075..... 1027	Tusa	4011, 4024	Gateway	5016		
Philips Magnavox	1020 2090..... 1042 2090..... 1042	TV86	4015	GOI	5013		
Pilot	1005	Zenith	2081..... 1033	Unika	4005, 4006	Hewlett Packard	5016		
Pioneer	1008	Cable		United Cable	4022	HNS	5002		
Polaroid	1040	(SAT-CAB / AUX 1 / AUX 2 Buttons)		Universal	4005, 4006	Howard Computers	5016		
Presidian	1039	ABC	4000, 4001, 4003, 4022, 4023	V2	4030	HP	5016		
Proscan	1000	Adelphia	4033, 4037	View Star	4009, 4014, 4015	HTS	5013		
Quarter	1003	Americast	4031	Viewmaster	4030	Hughes	5003, 5004, 5005, 5006, 5007, 5010, 5023		
Quartz	1003	Antronix	4005, 4006	Vision	4030	Humax	5010		
Quasar	1006	Archer	4006	Vortex View	4030	Hush	5016		
Radio Shack	1005	AT&T	4041	Zenith	4020, 4023, 4031	iBUYPOWER	5016		
Radio Shack/Realistic	1003, 1004, 1005, 1006, 1007	Bell South	4031	Zentek	4028	JVC	5013, 5014, 5023		
Radix	1005	Cable Vision	4038	Satellite Receiver				Linksys	5016
Randex	1005	Cabletenna	4005	(SAT-CAB / AUX 1 / AUX 2 Buttons)				Media Center PC	5016
RCA	1000, 1004, 1006, 1008, 1009, 1016, 1055	Cableview	4004	DIRECTV	3000, 3001, 3005, 3006, 3008, 3009, 3010, 3013, 3014, 3015, 3017, 3019, 3020, 3022, 3023, 3025, 3026, 3027, 3030, 3031, 3032, 3033, 3034, 3036, 3037, 3038, 3040, 3042, 3043, 3054, 3055, 3057, 3059, 3062, 3067	Microsoft	5016		
Realistic	1003, 1004, 1005, 1006, 1007	Clearmaster	4030 3010, 3013, 3014, 3015, 3017, 3019, 3020, 3022, 3023, 3025, 3026, 3027, 3030, 3031, 3032, 3033, 3034, 3036, 3037, 3038, 3040, 3042, 3043, 3054, 3055, 3057, 3059, 3062, 3067	Dish Network	5016	Mind	5016	
Ricoh	1012	ClearMax	4030 3012, 3016, 3050, 3058, 3060	Dish Network	5016	Niveus Media	5016	
Samsung	1004, 1032, 1044, 1050	Colour Voice	4008 3012, 3016, 3050, 3056, 3058, 3060	Dishpro	5013, 5014, 5023, 5025	Northgate	5016	
Sansui	1011, 1014, 1038	Comcast	4029, 4039, 4043, 4044 3012, 3016, 3050, 3056, 3058, 3060	Echostar	5015	Panasonic	5021, 5026	
Sanyo	1003, 1004, 1045	Contec	4009 3012, 3016, 3050, 3060	Expressvu	5015	Philips	5002, 5007, 5010, 5019, 5023, 5025	
Sears	1003, 1005, 1006, 1008, 1009	Coolmax	4030 3012, 3016, 3050, 3060	GE	5016	Proscan	5015	
Sharp	1037, 1051	COX	4029, 4044 3012, 3016, 3050, 3060	General Instrument	3007	RCA	5002, 5011, 5015, 5017, 5023	
Shintom	1001, 1009	Director	4029, 4044 3012, 3016, 3050, 3060	GOI	3014	ReplayTV	5018, 5021	
Shogun	1004	Eastern	4010 3012, 3016, 3050, 3060	Hisense	3007	Samsung	5002	
Singer	1006, 1012	Everquest	4024 3012, 3016, 3050, 3060	Hitachi	3011	Sonic Blue	5018, 5021	
Sony	1001, 1010, 1018, 1024, 1025, 1026, 1041, 1043, 1057	Focus	4028 3012, 3016, 3050, 3060	HTS	3017	Sony	5008, 5009, 5016, 5020, 5024	
STS	1006	GC Electronics	4006 3000, 3001, 3008, 3015, 3025, 3027, 3037, 3054, 3063	Hughes	3017	Stack 9	5016	
Superscan	1047	GE	4000 3002, 3037, 3054, 3063	Humax	3048	Systemax	5016	
Sylvania	1006, 1007, 1039, 1047, 1054	Gemini	4011, 4024 3002, 3037, 3054, 3063	Ilo	3011	Tagar Systems	5016	
Symphonic	1007, 1015, 1039	General Instrument	4000, 4027, 4029, 4039, 4044 3002, 3037, 3054, 3063	Jerrold	3007	Tivo	5003, 5004, 5005, 5006, 5008, 5009, 5010, 5019, 5020, 5023	
Tandy	1003	Goldstar	4025 3003, 3012, 3016, 3050, 3056	Jerrold	3007	Toshiba	5012, 5016	
Tashiko	1005	Hamlin	4012, 4013 3003, 3012, 3016, 3050, 3056	JVC	3007	Touch	5016	
Tatung	1011	Hitachi	4000 3010, 3044	LG	3006	UltimateTV	5015, 5017	
Teac	1007, 1011	Jasco	4024 3010, 3044	Magnavox	3006	Viewsonic	5016	
Technics	1006	Jerold	4000, 4011, 4022, 4024, 4027, 4029, 4044 3006	Memorex	3006	Voodoo	5016	
Teknika	1005, 1006, 1007	Magnavox	4014 3015, 3027	Mitsubishi	3015, 3027	ZT Group	5016	
		Memorex	4023						
		Motorola	4027, 4029, 4034, 4035, 4036, 4041, 4043, 4044, 4048						
		Movie Time	4015						
		Multitech	4030						

Warranty –U.S. and Canada

The Warranty below is valid only for sales to consumers in the United States or Canada. KLIPSCH, L.L.C. ("KLIPSCH") warrants this product to be free from defects in materials and workmanship (subject to the terms set forth below) for a period of five (5) years from the date of purchase. During the Warranty period, KLIPSCH will repair or replace (at KLIPSCH's option) this product or any defective parts (excluding electronics and amplifiers). For products that have electronics or amplifiers, the Warranty on those parts is for a period of two (2) years from the date of purchase.

To obtain Warranty service, please contact the KLIPSCH authorized dealer from which you purchased this product. If your dealer is not equipped to perform the repair of your KLIPSCH product, it can be returned, freight paid, to KLIPSCH for repair. Please call KLIPSCH at 1-800-KLIPSCH for instructions. You will need to ship this product in either its original packaging or packaging affording an equal degree of protection.

Proof of purchase in the form of a bill of sale or receipted invoice, which is evidence that this product is within the Warranty period, must be presented or included to obtain Warranty service.

This Warranty is invalid if (a) the factory-applied serial number has been altered or removed from this product or (b) this product was not purchased from a KLIPSCH authorized dealer. You may call 1-800-KLIPSCH to confirm that you have an unaltered serial number and/or you purchased from a KLIPSCH authorized dealer.

This Warranty is only valid for the original purchaser and will automatically terminate prior to expiration if this product is sold or otherwise transferred to another party.

This Warranty does not cover cosmetic damage or damage due to misuse, abuse, negligence, acts of God, accident, commercial use or modification of, or to any part of, the product. This Warranty does not cover damage due to improper operation, maintenance or installation, or attempted repair by anyone other than KLIPSCH or a KLIPSCH dealer which is authorized to do KLIPSCH warranty work. Any unauthorized repairs will void this Warranty. This Warranty does not cover product sold AS IS or WITH ALL FAULTS.

REPAIRS OR REPLACEMENTS AS PROVIDED UNDER THIS WARRANTY ARE THE EXCLUSIVE REMEDY OF THE CONSUMER. KLIPSCH SHALL NOT BE LIABLE FOR ANY INCIDENTAL OR CONSEQUENTIAL DAMAGES FOR BREACH OF ANY EXPRESS OR IMPLIED WARRANTY ON THIS PRODUCT. EXCEPT TO THE EXTENT PROHIBITED BY LAW, THIS WARRANTY IS EXCLUSIVE AND IN LIEU OF ALL OTHER EXPRESS AND IMPLIED WARRANTIES WHATSOEVER, INCLUDING BUT NOT LIMITED TO, THE WARRANTY OF MERCHANTABILITY AND FITNESS FOR A PARTICULAR PURPOSE.

Some states do not allow the exclusion or limitation of incidental or consequential damages or implied warranties so the above exclusions may not apply to you. This Warranty gives you specific legal rights, and you may have other rights, which vary from state to state.

Warranty Outside the United States and Canada

The Warranty on this product if it is sold to a consumer outside of the United States or Canada shall comply with applicable law. To obtain any applicable warranty service, please contact the dealer from which you purchased this product, or the distributor that supplied this product.

License Notice and Trademark Acknowledgments

- This product is manufactured under license from Dolby Laboratories.
- This product is manufactured under license from Digital Theater Systems, Inc.
- "Dolby", "ProLogic" and the Double-D Symbol are trademarks of Dolby Laboratories.
- "DTS" and "DTS Digital Out" are trademarks of Digital Theater Systems, Inc.
- HDMI, the HDMI logo and High-Definition Multimedia Interface are trademarks or registered trademarks of HDMI Licensing, LLC.

FCC Information

This device complies with Part 15 of the FCC Rules. Operation is subject to the following: (1) This device may not cause harmful interference, and (2) this device must accept any interference received, including interference that may cause undesired operation.

This equipment has been tested and found to comply with the limits for a Class B digital device, pursuant to Part 15 of the FCC Rules. These limits are designed to provide reasonable protection against harmful interference in a residential installation. This equipment generates, uses and radiates radio frequency energy and, if not installed and used in accordance with the instruction, may cause harmful interference to radio communications. However, there is no guarantee that interference will not occur in a particular installation.

In accordance with FCC requirements, changes or modifications not expressly approved by Klipsch could void the user's authority to operate this product.

This device generates and uses radio frequency (RF) energy, and if not installed and used properly, this equipment may cause interference to radio and television reception.

If this equipment does cause interference to radio or television reception (which you can determine by unplugging the unit), try to correct the interference by one or more of the following measures:

- Re-orient the receiving antenna (that is, the antenna for the radio or television that is "receiving" the interference).
- Move the unit away from the equipment that is receiving interference.
- Plug the unit into a different wall outlet so that the unit and the equipment receiving interference are on different branch circuits.

If these measures do not eliminate the interference, please consult your dealer or an experienced radio/television technician for additional suggestions.

Also, the Federal Communications Commission has prepared a helpful booklet, "How To Identify and Resolve Radio TV Interference Problems." This booklet is available from the U.S. Government Printing Office, Washington, DC 20402. Please specify stock number 004-000-00345-4 when ordering copies.

This product complies with DHHS Rules 21 CFR Subchapter J. Applicable at the date of manufacture.

This Class B digital apparatus complies with Canadian ICES-003. Cet appareil numérique de la classe B est conforme à la norme NMB-003 du Canada.

FCC Declaration Of Conformity

Trade Name:	Klipsch Audio Technologies
Product Name:	DVD Audio/Video System
Model Number:	CS-700
Responsible Party	
Manufacturer:	Klipsch Audio Technologies
Address:	3502 Woodview Trace, Suite 200 Indianapolis, IN 46268
Telephone:	317-860-8100
Date:	1/15/2006

These devices were tested and found to comply with Part 15 of the FCC Rules. Operation is subject to the following conditions: The devices may not cause harmful interference, and the devices must accept any interference received, including interference that may cause undesired operation.

CHANGES OR MODIFICATIONS NOT EXPRESSLY APPROVED BY THE PARTY RESPONSIBLE FOR COMPLIANCE WITH THE FCC'S RULES (THE FCC' THE GRANTEE') COULD VOID THE USER'S AUTHORITY TO OPERATE THE EQUIPMENT

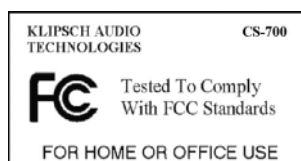

Precautions





The radiated output power of this device is below the FCC radio frequency exposure limits based on that human proximity to the antenna shall not be less than 20cm during normal operation.

IC notice

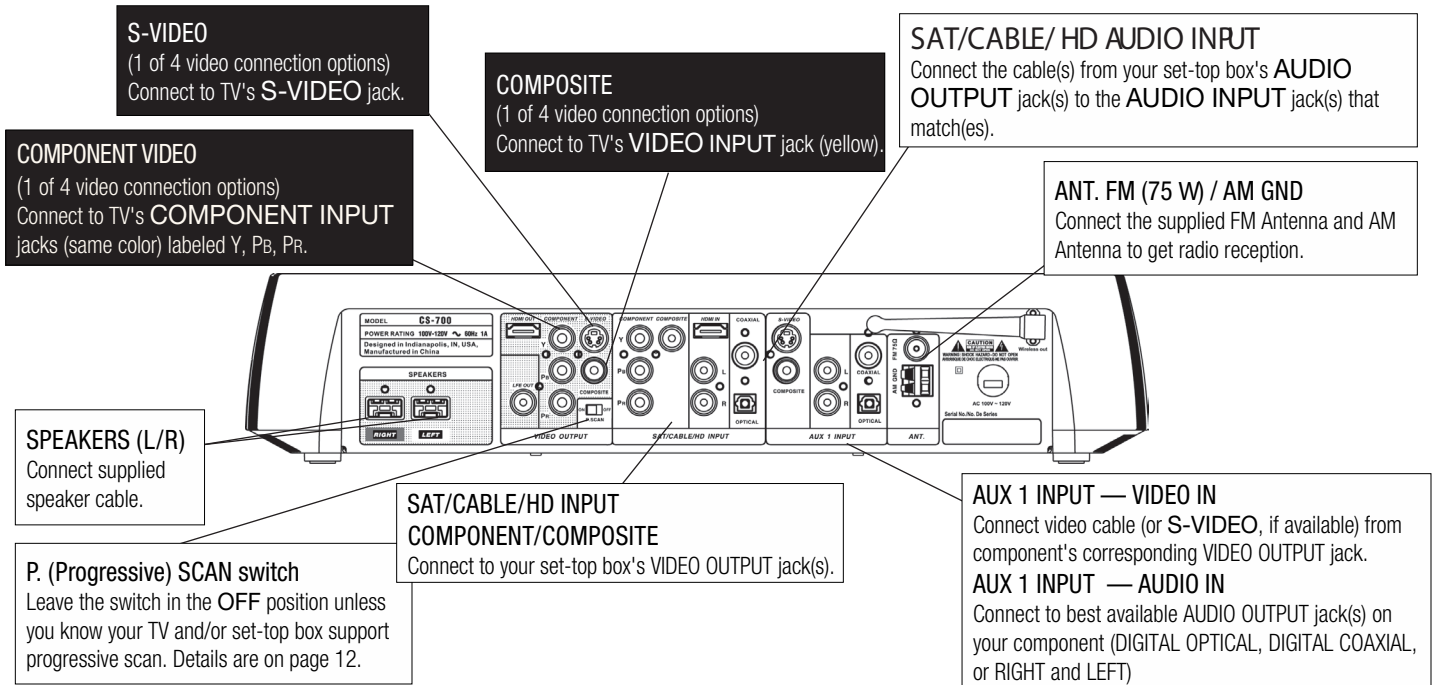
To reduce potential radio interference to other users, the antenna type and its gain should be so chosen that the equivalent isotropically radiated power (e.i.r.p.) is not more than that permitted for successful communication.

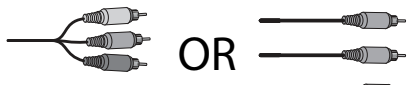
Appendix I - Connection Overview

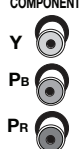

Video Connection Options	Cables	Jacks
<p>COMPONENT Video is considered excellent video quality because the video is separated into three parts</p> <p>Y = Luminance (black & white part of signal) Pb= Chrominance (color) minus blue Pr = Chrominance minus red</p> <p>S-VIDEO (separate video) provides very good video quality. Even though there is only one cable, the chrominance and luminance are kept separate from the main signal.</p> <p>COMPOSITE (yellow) provides good video quality.</p> <p>This is a digital connection.</p>	 <p>OR</p> <p>Bundled Set Not supplied</p> <p>3 Video Grade Cables Not supplied</p>  <p>S-VIDEO cable Not supplied</p>  <p>COMPOSITE video cable Supplied</p> 	<p>COMPONENT</p>  <p>Y Pb Pr</p>