

Smart TV Box

DV6800 User Manual

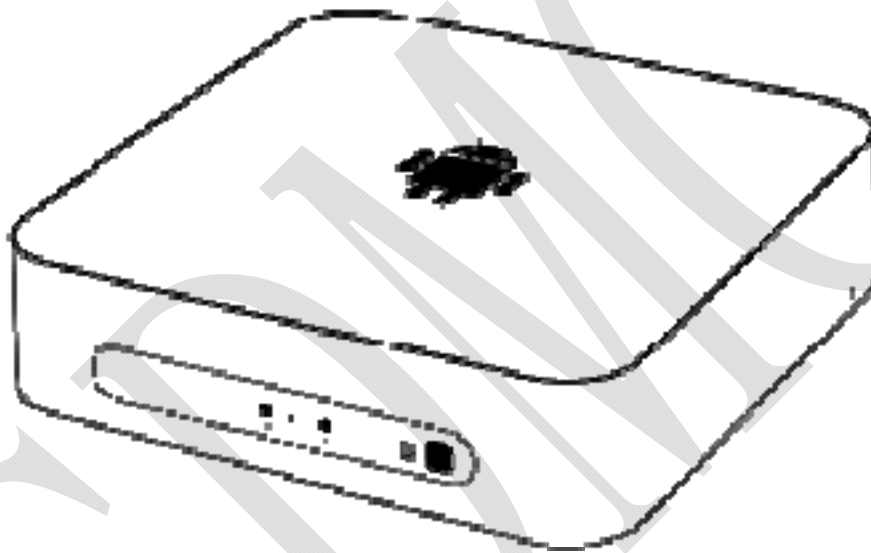

Shenzhen SDMC Technology Co. Ltd

ADD: 7F,W2-A, Hi-Tech. Industrial Park, Nanshan District, Shenzhen, China

Tel: +86-755-86016429

Content

Content	2
1 Instructions	3
1.1 Safety Instruction	3
2 Product Brief	3
2.1 Accessory List	3
2.2 Remote Control.....	4
2.3 System Connection	5
3 Main Menu	6
4 Network Setting	6
4.1 Connect with Wi-Fi	6
4.2 Connect with Ethernet.....	6
5 App	6
5.1 Install Applications.....	7
5.2 Uninstall Applications	7
6 Phone Control	7
7 System Update	7
8 Technical Specifications	8
9 Troubleshooting	9

1 Instructions

The instructions will give you specific guidance on installation, operation and maintenance of the product, please go through the instructions first before using the TV box.

Disclaimer: The original company reserves the right to improve the content. If there has discrepancy between pictures and text, Please subject to the final in-kind operation.

1.1 Safety Instruction

- ❖ Please keep the product in horizontal position. Do not put any heavy stuff on the top of the TV box.
- ❖ Please use the provided power adapter. Do not use the damaged power cable and plug.
- ❖ Please avoid to plug power adapter with wet hands.
- ❖ Please do not disassemble, modify machine by yourself to avoid any shock and damage to the TV box
- ❖ Please keep the machine away from the heat source to avoid to damage the TV box, it should be put in a well ventilation place.
- ❖ Please keep the TV box away from damp and dusty environment to avoid fire and electric shock.
- ❖ Please prompt shut down and unplug power adapter when the machine emitting smoke or having special smell.
- ❖ Please unplug the power adapter when long time not using the TV box.

2 Product Brief

2.1 Accessory List

Open the giftbox to check below accessories:



TV Box x1



Remote and Battery x1

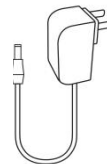

Power Adapter x1

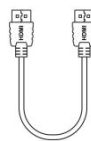

HDMI Cable x1

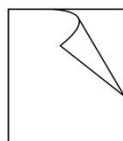

User Manual x1

2.2 Remote Control

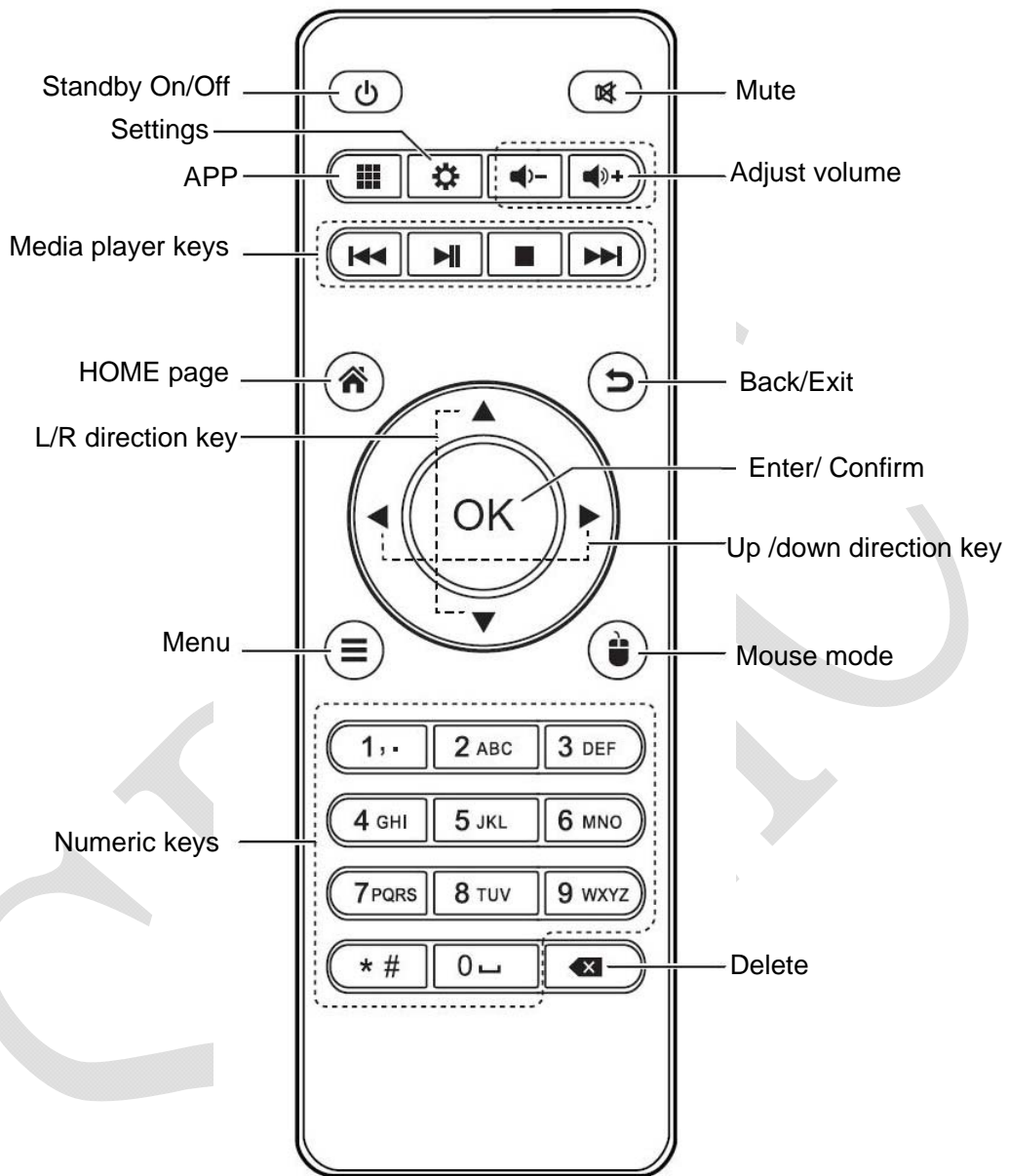

【Note】 : Functions of the remote control maybe different for different Apps, you may need to use an external mouse to operate it.

2.3 System Connection

Please refer to below pictures and instructions to connect TV, Power, Network and other devices.

Note: Before connecting please shut down all the equipment to be connected (such as this machine and TV power)

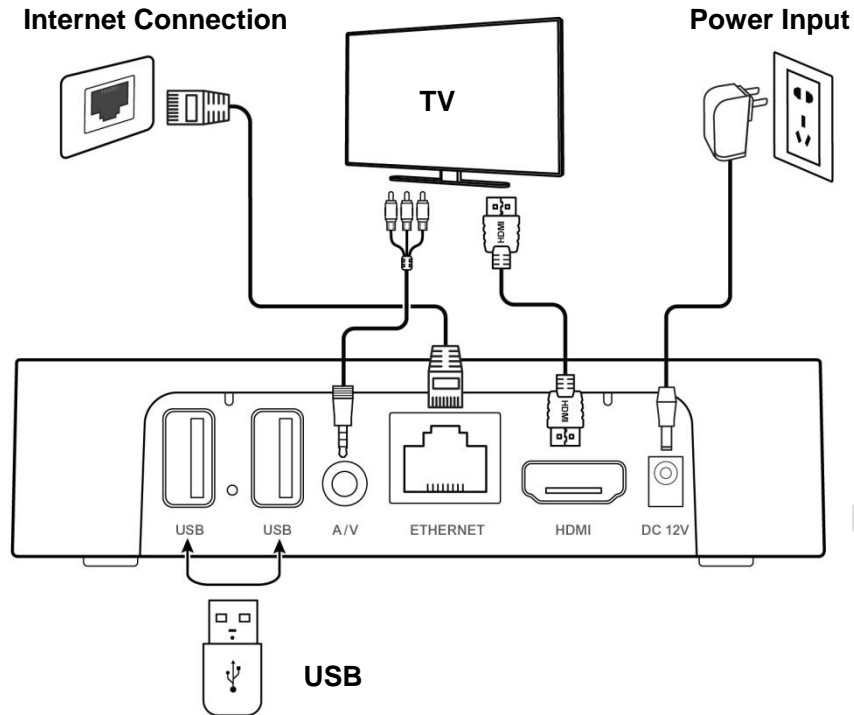

Step1 Connection with TV

Connect HDMI/AV cable to HDMI/AV port of the TV box and TV set

Step2 Connection with network

Plug the Ethernet cable to LAN Port of the TV box, the other side to LAN port of router or Ethernet port of home broadband network.

Step3 Connection with Power

Connect the power adapter to the TV box. After power in on, it can start automatically.

Note: Before powering on, Please switch the signal input of the TV to correct source.

Tips: The TV box support Wi-Fi, See **Network Setting** section

3 Main Menu

❖ Main Menu

Quick application/function areas The Status Bar

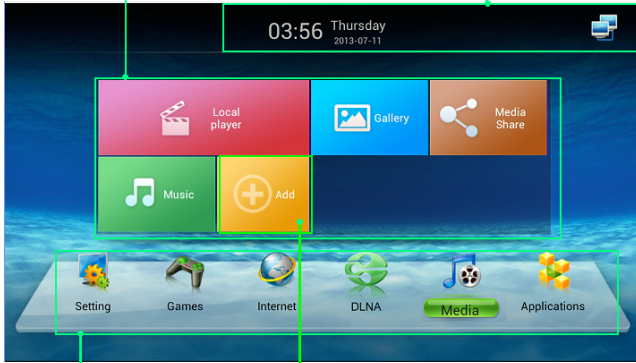

Navigation Bar Add/Delete App

- **The Status Bar:** Show current date, time, network and connect statue of USB
- **Navigation Bar:** Application classification
- **Quick application/function areas:** Show commonly used functions or applications for each classification

❖ Operate Instruction

- ❖ **Navigation bar:** Pressing【◀▶】button can switch classification, pressing【▲】button enter function area/application area, pressing【OK】button enter application.
- ❖ **Function area:** Pressing【◀▶】button Select application, pressing【OK】button start application;
- ❖ **Add/Delete APP:** Select and enter “+” icon to add or delete application icon on desktop

4 Network Setting

Enter Setting



4.1 Connect with Wi-Fi

Select **Wi-Fi**, turn on Wi-Fi and connect an available Wi-Fi network with correct password

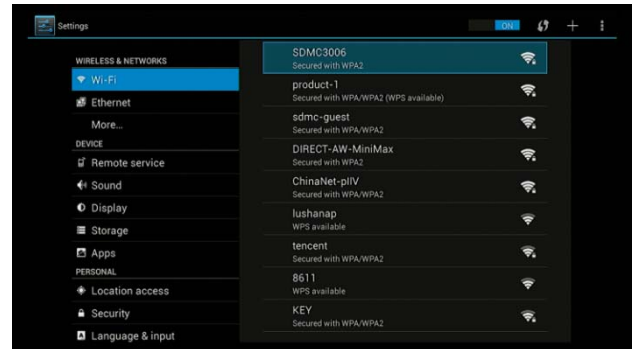

【Note】 Please do not plug the Ethernet cable when using Wi-Fi

4.2 Connect with Ethernet

Select **Ethernet**, turn on Ethernet, If cannot connect network with automatic IP, entering **Ethernet configuration** and set network parameters manually.



【Note】 : When using wired network, the TV box will automatically close wireless network.

5 App

Enter **APP** classification, show all applications



5.1 Install Applications

❖ Install from app store

After connecting network, you can install app from app store (such as google play).

❖ Install via U disk or SD card

- 1) Insert the U disk or SD card that stores .apk files.
- 2) Navigate to the .apk file using file browser and select it, it will open a dialog box allowing you to install the app, select “**Install**” and “**Install**” again to install the .apk.

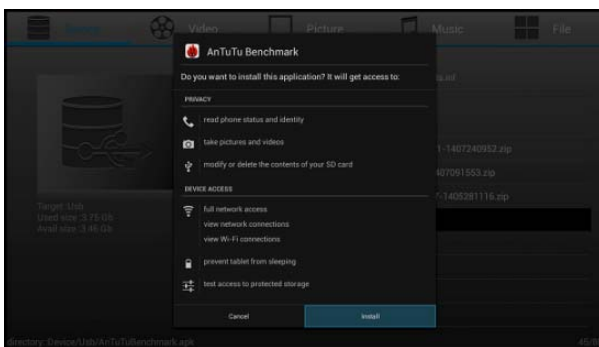

The new application will appear in **APP** classification menu after installation..

5.2 Uninstall Applications

Enter **Settings**→**APPS**, a list of installed applications will appear, select the one to be uninstalled and simply click Uninstall

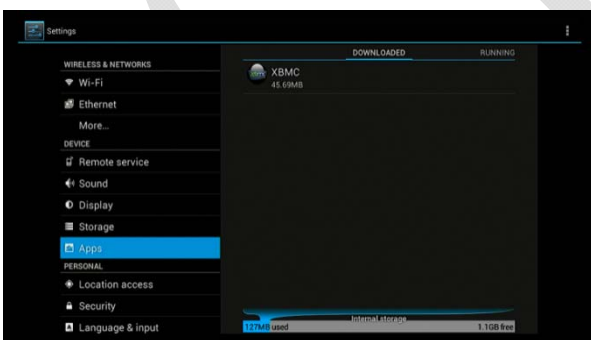

6 Phone Control

Enter **Settings**→**Remote service**, follow the prompts to download and install the client as shown below.

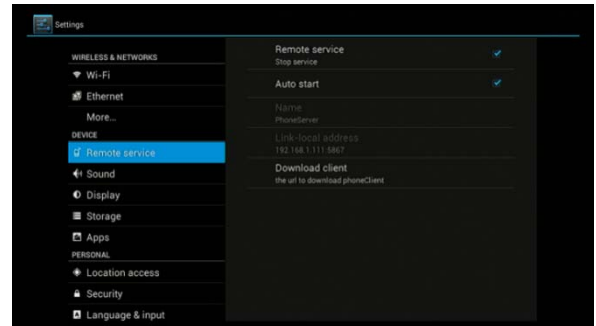

Notice: The smart phone or tablet should be in same LAN with this machine.

7 System Update

Enter **Settings**→**System Update**



❖ OTA Update:

Enter **OTA update** from software update menu, ensure that the device connected to the internet, the system will automatically check for updates.

❖ System update

Insert the U-disk that stores upgradable files, enter **USB upgrade**, choose the upgradable file to begin the upgrade.

Note: Please avoid closing power or removing USB storage device when software is updating.

8 Technical Specifications

CPU	ARM Dual-core Cortex-A9 1.5GHz
Operation system	Android 4.2
Video output	HDMI, CVBS
Audio output	Optical
Video format	H.264, MPGE, MKV, MP4 and other video formats
Audio format	AAC, WAV, MP3 and other audio formats
Photo format	JPG, BMP, PNG and other photo formats
Network	Wi-Fi 2.4G 802.11b/g/n
	RJ45 Interface 10M/100M adaptive
Operation temperature	Temperature: 0°C~40°C; Humidity:<95%
Power	Input: AC100-240V 50/60Hz
	Output: DC 12V/1A
Power consumption	Work: <8W; Standby: <0.5W;

9 Troubleshooting

Issue	Possible reason	Solution
After turned on, without any display	The power cord Doesn't connect or socket without electricity	Connected power plug, ensure normal voltage electrical outlet
TV with images without Voice	Audio cable is not connected	Re-connect the Audio cable
	TV Box in MUTE state	Please press mute button to restore volume
	Audio setting is abnormal	Please enter the audio and video Settings menu, select the appropriate sound channel and language
	Volume is too low	Turn up the volume
Fail to connect the network	Cable connect is abnormal	Please reconnect internet
	Wi-Fi closed or the signal is too weak	Please restart the Wi-Fi or adjust the position of this machine
Controller failure	Remote control is not in the correct direction	Please aim at the front panel's 'SENSOR', then try again
	Remote control is with low battery	Please change the batteries
	Remote control is broken	Please send it to the local maintenance station for checking

FCC Statement

This device complies with part 15 of the FCC Rules. Operation is subject to the following two conditions: (1) This device may not cause harmful interference, and (2) this device must accept any interference received, including interference that may cause undesired operation.

Any Changes or modifications not expressly approved by the party responsible for compliance could void the user's authority to operate the equipment.

Note: This equipment has been tested and found to comply with the limits for a Class B digital device, pursuant to part 15 of the FCC Rules. These limits are designed to provide reasonable protection against harmful interference in a residential installation. This equipment generates uses and can radiate radio frequency energy and, if not installed and used in accordance with the instructions, may cause harmful interference to radio communications. However, there is no guarantee that interference will not occur in a particular installation. If this equipment does cause harmful interference to radio or television reception, which can be determined by turning the equipment off and on, the user is encouraged to try to correct the interference by one or more of the following measures:

- Reorient or relocate the receiving antenna.
- Increase the separation between the equipment and receiver.
- Connect the equipment into an outlet on a circuit different from that to which the receiver is connected.
- Consult the dealer or an experienced radio/TV technician for help.

*RF warning for Mobile device:

This equipment complies with FCC radiation exposure limits set forth for an uncontrolled environment. This equipment should be installed and operated With minimum distance 20cm between the radiator & your body.

IC Caution.

This device complies with Industry Canada licence-exempt RSS standard(s). Operation is subject to the following two conditions: (1) This device may not cause interference, and (2) This device must accept any interference, including interference that may cause undesired operation of the device.

This equipment should be installed and operated with a minimum distance of 20 cm between the radiator and your body.

Le présent appareil est conforme aux CNR d'Industrie Canada applicables aux appareils radio exempts de licence. L'exploitation est autorisée aux deux conditions suivantes:

- (1) l'appareil ne doit pas produire de brouillage, et
- (2) l'utilisateur de l'appareil doit accepter tout brouillage radioélectrique subi, même si le brouillage est susceptible d'en compromettre le fonctionnement.

Cet équipement doit être installé et utilisé à une distance minimale de 20 cm entre le radiateur et votre corps.

CE 2200