

## CHAPTER 3. INSTALLATION

This chapter describes procedures for installing the RA40C/41C/42C radar in your ship and precautions to be observed during installation. Follow the procedure below to install the radar.

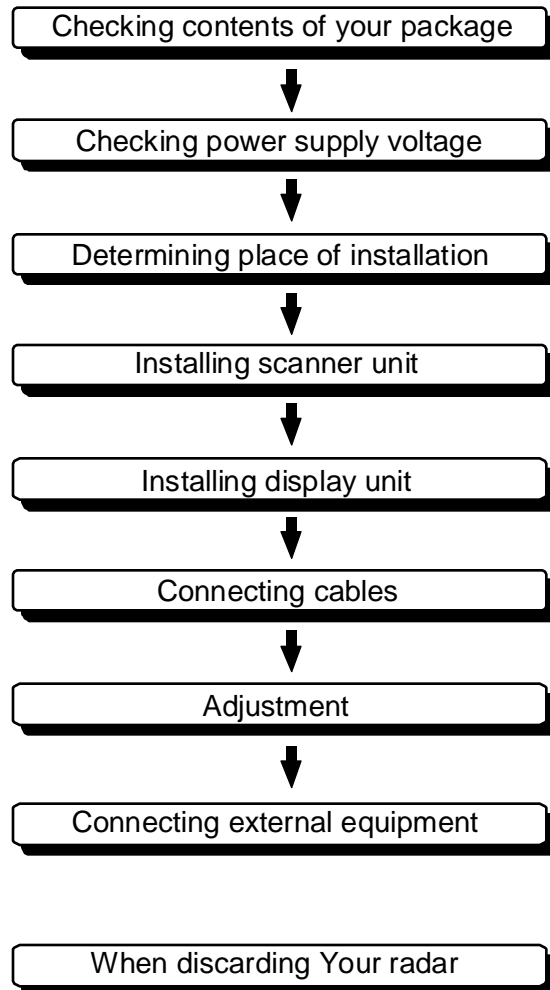

### 3.1 Checking Contents of Your Package

---

First, unpack your package and see if all of the following items are included.

	<b>Item</b>	<b>RA40C Q'TY</b>	<b>RA41C Q'TY</b>	<b>RA42C Q'TY</b>	
(RF719A)	Display unit	1 (RF719A)	1 (RF719A)		1
(RB716A)	Scanner unit	1 (RB714A)	1 (RB715A)		1
	Display cover	1	1		1
	Fuse	2	2		4
	Interconnecting cable	1 (10 m)	1 (10 m)		1 (10 m)
	Power supply cable	1 (2 m)	1 (2 m)		1 (2 m)
	M10 hexagonal bolt	4 sets	4 sets		0
	M12 hexagonal bolt	0	0		4 sets
	Carbon brush	0	0		2

The package contains a 10m interconnecting cable as an accessory. Longer cable is also available as an option as listed in Tab.3-1.

**Tab.3-1 Optional Interconnecting Cable**

	<b>RA40C</b>	<b>RA41C</b>	<b>RA42C</b>
<b>Cable length</b>	<b>Product No.</b>	<b>Product No.</b>	<b>Product No.</b>
15m	242J160680B	24Y159099B	24Y159169B
20m	242J160680C	24Y159099C	24Y159169C
25m		24Y159099D	24Y159169D
30m	242J160680D		

In addition to the above components included with your package, the following items are also required. Please prepare them separately.

<b>Item</b>	<b>QTY</b>	<b>Remarks</b>
Tapping screw or M5 bolt and nut	6 sets	To install display unit
Grounding wire	1	Earth line for display unit
Grounding wire and crimp terminal	1 set	Earth line for scanner unit

### 3.2 Checking Power Supply Voltage

#### 3.2.1 Power Supply Requirements

For the RA40C/41C/42C radar to be operated normally, the power supply (battery) detailed in Tab.3-2 is required. Note also that if the battery is discharged, its voltage may fluctuate greatly, causing the radar to malfunction. When start up the radar system or start transmitting, an additional rush current is required on the power line. Carefully check the power supply system including wiring by using a circuit tester.

**Tab.3-2 Power Supply Requirements**

<b>Supply voltage used</b>	<b>Maximum current</b>	<b>Allowable range of voltage</b>
DC12V	5A	10.2-41.6V
DC24V	2.5A	10.2-41.6V

\*A.C. power cannot be used

#### 3.2.2 Fuse Replacement

For the RA40C/41C/42C radar to be operated safely, proper rating fuses must be used. Tab.3.3 and Tab.3.4 are fuse rating tables for RA40C/41C and RA42C. Check them and replace to the fuse in the package.

**Tab.3-3 Supply Voltage to Fuse Table for RA40C/41C**

<b>Supply voltage used</b>	<b>Main Fuse</b>	<b>Motor Fuse</b>
DC12V	8A/250V or 125V * (6.3• x 32mm)	T3.15A/250V or 125V * (5• x 20mm)
DC24V	8A/250V or 125V (6.3• x 32mm)	T3.15A/250V or 125V (5• x 20mm)

**Tab.3-4 Supply Voltage to Fuse Table for RA42C**

Supply voltage used	Main Fuse	Motor Fuse
DC12V	10A/250V or 125V (6.3 • x 32mm)	5A/250V or 125V (5 • x 20mm)
DC24V	8A/250V or 125V * (6.3 • x 32mm)	T3.15A/250V or 125V * (5 • x 20mm)

...Note: Marked \* fuses are in the set as standard.

### 3.3 Determining Place of Installation

#### 3.3.1 Scanner unit

A radar's target detection capacity varies greatly depending on the fitted position of the scanner. An ideal fitting position is a location high above the ship's keel line where there is no obstacle all around the scanner. In an actual ship, such an ideal location is limited by various factors. Therefore, consider the following suggestions when you determine the place to install the scanner:

**(a) Install scanner at a position as high as possible.**

The higher the installation position, the longer the radio ranging distance. Install the scanner at a position as high as possible after considering the ship's hull structure and radar maintainability.

**(b) Install scanner away from smoke-stack and mast**

If the scanner is installed at the same height as the smoke-stack or mast, radar waves may be blocked, creating shadow zones or generating false echoes. Therefore, do not install the scanner at such a position.

**(c) Install scanner forward away from obstacle.**

To avoid creating shadow zones or generating false echoes, install the scanner at a position nearer to the ship's bow away from obstacles. When installing the scanner on a mast, position it in front of the mast. (If obstacles cannot be avoided for the ship's structural reasons, refer to "Shifting away from obstacles" described Page 13.)

**(d) Do not install the scanner near hot or heat-generating items.**

Do not install the scanner at a position where it may be subjected to smoke or hot air from smokestacks or heat from lamps.

**(e) Install the scanner away from antennas of other equipment.**

Install the scanner as much away from the antennas of a direction finder, radio transceiver, etc. as possible.

 **CAUTION**  
**To eliminate the interference, install the scanner  
away from the antenna of radio transceivers.**

**(f) Make the cable length as short as possible.**

Keep the distance from the scanner to the display unit within the standard cable length of 10 m. If you use longer cable for unavoidable reasons, limit the cable length to a maximum of 30 m for RA40C and 100 m for RA41C/42C.

#### 3.3.2 Display unit

The display unit can be installed on desktop, wall surface, or ceiling. Determine the place to install the display unit that is convenient for navigation and radar operation after considering the following suggestions:

- (a) A place where you can see the ship's bow when you raise your face from the radar screen.
- (b) A place where there is no direct sun-light to avoid display temperature up.
- (c) A place where there is good ventilation and minimum vibration.
- (d) A place where the display unit is apart more than the minimum safe distance from a magnet compass as listed in Tab.3-5 below.

**Tab.3-5 Minimum Safe Distance from Magnetic Compass**

	Master compass	Steering compass
Scanner unit	2.0m	1.4m
Display unit	2.0m	1.4m

### 3.3.3 Shifting away from obstacles

#### ① Shifting from keel line

By shifting the scanner position from the keel line to the starboard side of the ship, it is possible to move shadow zones to the port side which makes it possible to keep clear vision in the bow direction. The distance to be shifted can be obtained by calculation depending on the distance from the scanner to obstacles using the following equation:

$$L_s = 0.4R + D/2 \text{ [m]} \quad (\text{when } R < 15\text{m})$$

$$L_s = 0.025R + D/2 \text{ [m]} \quad (\text{when } R \geq 15\text{m})$$

where  $L_s$  = distance to be shifted from keel line  
 $D$  = diameter of obstacle on keel line  
 $R$  = distance from scanner to obstacle

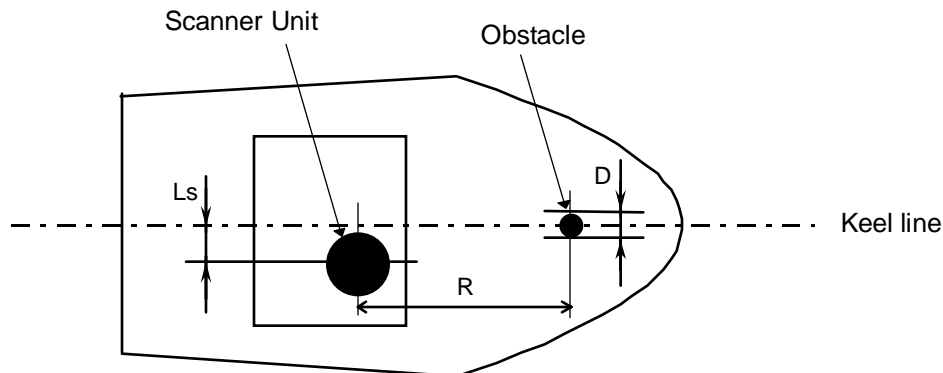

**Fig.3-1 Shifting from keel line**

#### ② Obtaining sufficient dip angle

Raise the scanner position so that there is a sufficient dip angle  $\theta$  available between the line of sight from the scanner to the obstacle and the horizontal line. By raising the dip angle above  $5^\circ$ , it is possible to prevent mid- and long-distance shadow zones. The radar cannot detect objects below the line of sight.

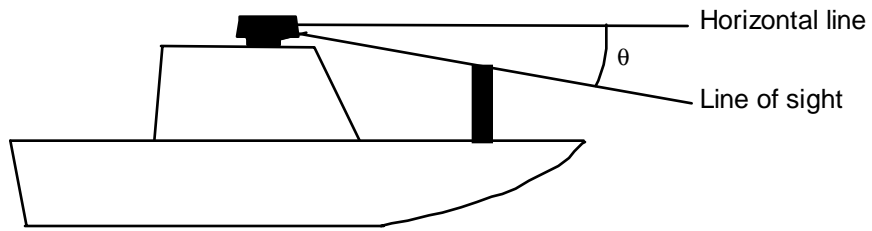
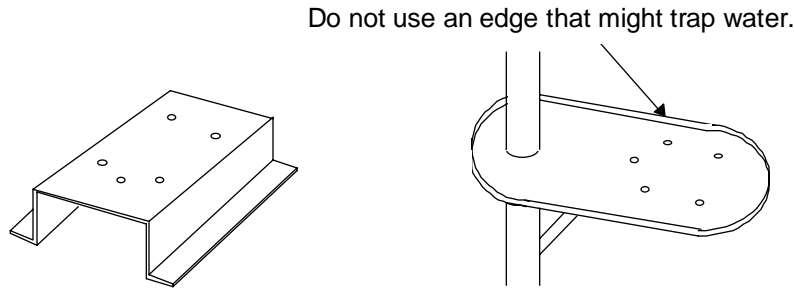

**Fig.3-2 Obtaining sufficient dip angle**

### 3.4 Installing Scanner Unit

When you have decided the place of installation, install the scanner unit. If a mount base like the one shown below is available, it may be easier to install the scanner. If such a mount base is not available in your ship, you may install the scanner directly to the roof, etc. In such a case, pay attention to the water drain tube located at the bottom of the scanner unit during installation.

Note : When the radar mast or mounting bracket has a curvature of more than 2mm, repair it or use spacers.



**Fig.3-3 Mount base**

Referring to Fig.3-4, open holes in diameter of 12 mm (0.47 in.) at five locations in the mount base and use these holes to fix the scanner unit to the mount base with hexagonal bolts. (Use the template included with this manual.) The bolts included with your radar equipment will suffice for mount base thickness of 9 to 14 mm (0.35 to 0.55 in.). If the mount base is thicker or thinner than this, prepare bolts listed in Tab.3-6.

Use sealing of silicon when you prevent the bolts from becoming loose. Radome may be broken if you use locking putty.

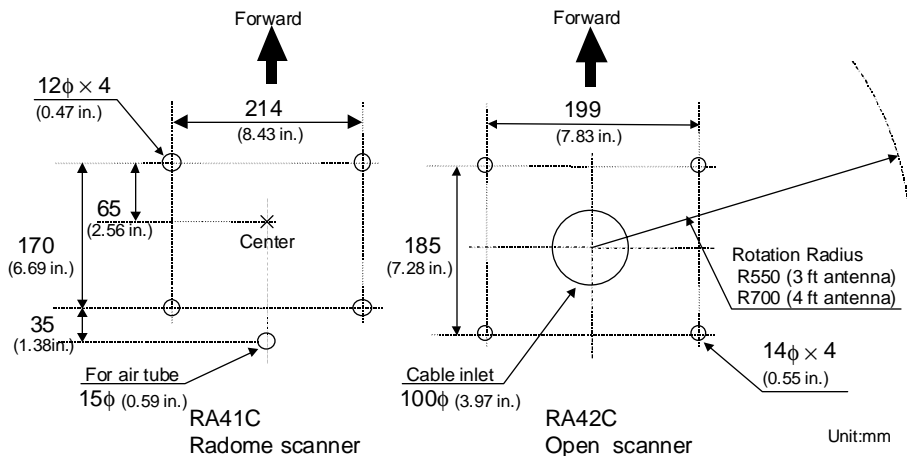

**Fig.3-4 Hole positions for mounting scanner**

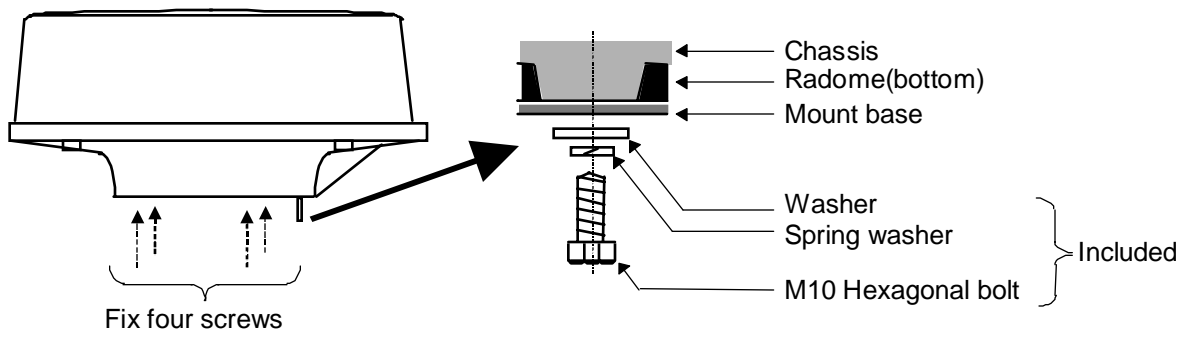

RA40C/41C Radome scanner

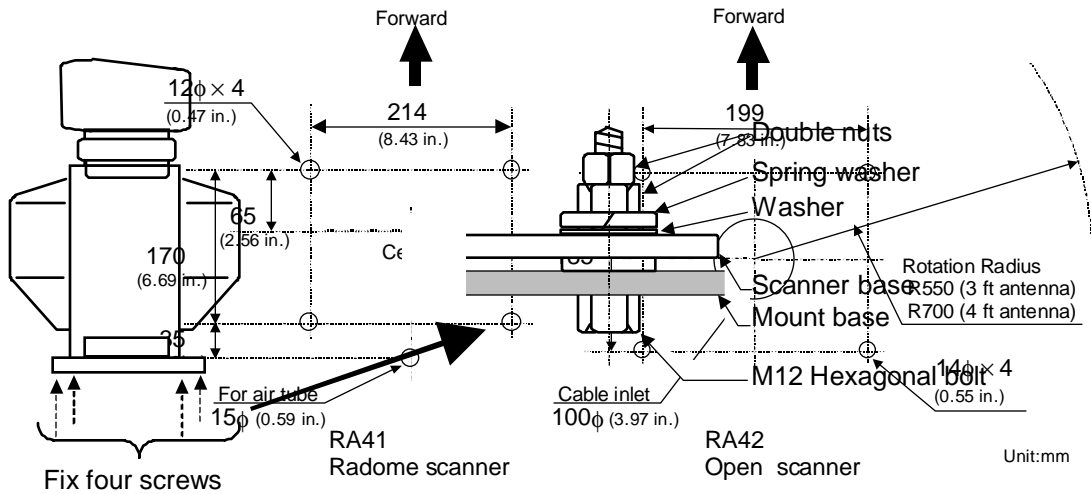

RA42C Open scanner

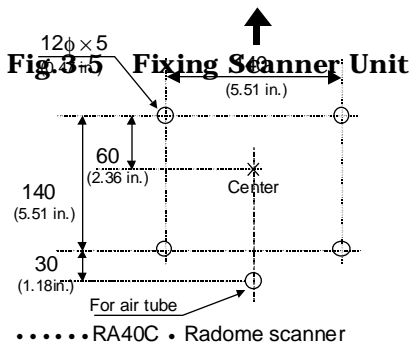

Tab.3-6 Bolts for Mounting Scanner Unit

Thickness of mount base	Bolts necessary to fix radome scanner	Material	Remarks
1-4mm(0.04-0.16 in.)	M10/M12 × 15 (1.5mm pitch)	Stainless	
4-9mm(0.16-0.35 in.)	M10/M12 × 20 (1.5mm pitch)	Stainless	
9-14mm(0.35-0.55 in.)	M10/M12 × 25 (1.5mm pitch)	Stainless	Included with radar
14-19mm(0.55-0.75 in.)	M10/M12 × 30 (1.5mm pitch)	Stainless	

3.5 Installing Antenna Unit

Remove the protective cap covering the rotary coupler on the top of the scanner. Match the antenna radiation direction to direction of the arrow markings on the rotation base and fix the antenna in position using the four M8 accessory bolts.

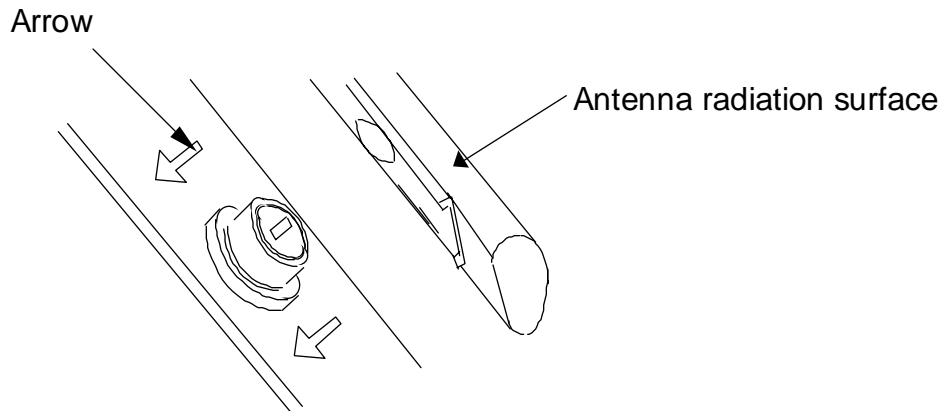

### 3.6 Installing Display Unit

After you have finished installing the scanner unit, install the display unit in the same way. Choose the proper bolt length according to the thickness of the surface on which you are going to install the display unit. Hole diameter is different using bolts from using tapping screw. When using tapping screw, open holes in adequate holes. When using bolts and nuts, open holes in diameter of 6 mm (0.24 in.). When you have opened holes, install the pedestal part first and then the display unit.

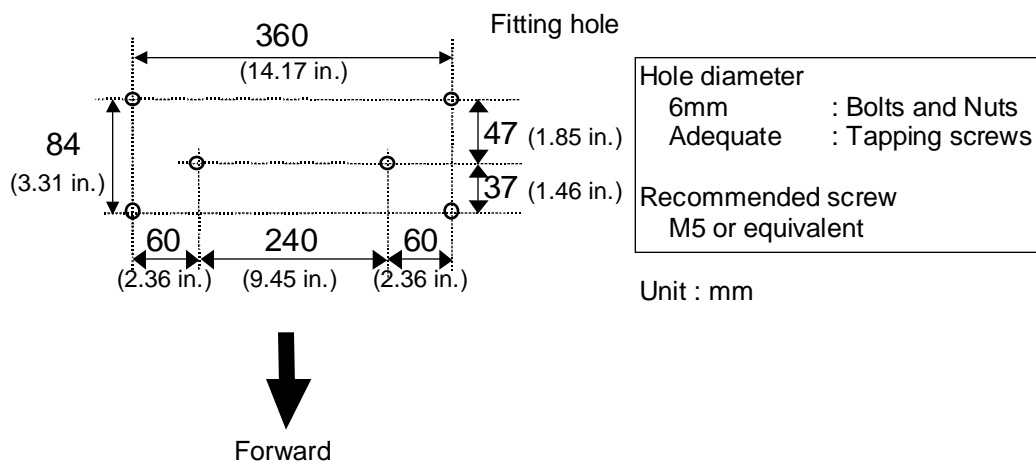

**Fig.3-6 Hole positions for display unit**

Note : When you install the display by flush mount, refer to appendix "OUTLINE DRAWING". Slide off four triangle corner cover, and fix the display unit to the panel with screws. After fixing the display unit, put on corner covers to the corner of the display unit. See APPENDIX.



 **WARNING**

**Avoid a display from operating under direct sunlight. It becomes high temperature at inside of display and display may be broken.**

### 3.7 Connecting Cables

Lay cables firmly in place by following the instructions below.

- Note1: Do not bind the cable for the radar collectively with cables of other equipment (especially power supply cable).
- Note2: Leave clearance near the inlet of the display so you can remove the display unit easily. This facilitates installation and maintenance of the display unit. (Refer to Appendix.)
- Note3: Because the cable has a connector fitted on the display and scanner side, if it is necessary to pass cable through a narrow path, fix the scanner-side connector vertically using vinyl tape before passing cable through the path.
- Note4: Lay cable along the ship's hull or wall surface and attach it in place at intervals of about 40 cm.

#### 3.7.0 Interconnecting cable (RA40C Radome scanner) (See Fig.3-8-1)

- ① Ensure that the radar is off. Connect the cable to the receptacle labeled "SCANNER" on the rear panel of the display unit.
  - ② Next, remove the upper part of the radome from the scanner unit. Avoid bumping it against the antenna by lifting vertically. (There are three fixing screws.)
  - ③ Remove the tape fixing the antenna.
  - ④ Remove the shield cover located on the astern side. (There are three fixing screws.)
  - ⑤ Remove the cable clamping plate and rubber ring, pass cable through the introduction opening, put the rubber ring from both ends of it, and clamp the cable to the scanner unit with screws via the fixing plate. Plug the connector fitted to the cable into the X1 connector on the PCB.
  - ⑥ Replace the aluminum cover. At this time, attach a cable shield onto a ditch with the aluminum cover. However, be careful that the cable will not be caught up between the main unit and cover.
- ⑦ Replace the upper part of the radome. Be careful not to bump it against the antenna in the same way as when removing it. Make sure that the cover is fitted in the correct direction as shown in Fig.3-7-1. The upper and lower parts of the radome each have three markings indicating screw positions. Align the upper and lower positions as you mount the radome.

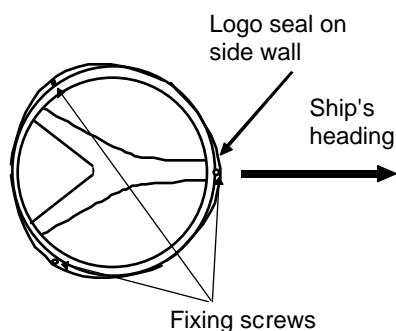
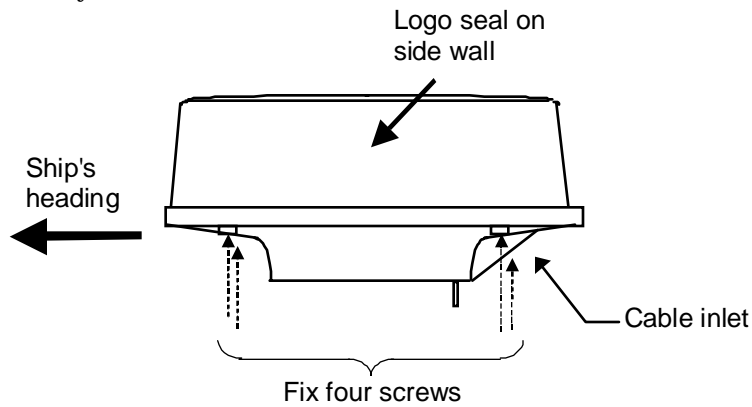

Fig.3-7-1 Fitting Cover (RA40C)

#### 3.7.1 Interconnecting cable (RA41C Radome scanner) (See Fig.3-8-2)

- ① Ensure that the radar is off. Connect the cable to the receptacle labeled "SCANNER" on the rear panel of the display unit.
- ② Next, remove the upper part of the radome from the scanner unit. Avoid bumping it against the antenna by lifting vertically. (There are four fixing screws.)
- ③ Remove the tape fixing the antenna.

- ④ Remove the shield cover located on the astern side. (There are four fixing screws.)
- ⑤ Remove the cable clamping plate and rubber ring, pass cable through the introduction opening, put the rubber ring from both ends of it, and clamp the cable to the scanner unit with screws via the fixing plate. Connect 7-pin connector to X11 and 9-pin connector to X12 of PCB.
- ⑥ Replace the aluminum cover. At this time, attach a cable shield onto a ditch with the aluminum cover. However, be careful that the cable will not be caught up between the main unit and cover.
- ⑦ Replace the upper part of the radome. Be careful not to bump it against the antenna in the same way as when removing it. Make sure that the cover is fitted in the correct direction as shown in Fig.3-7-2. The upper and lower parts of the radome each have four markings indicating screw positions. Align the upper and lower positions as you mount the radome.



**Fig.3-7-2 Fitting cover (RA41C)**

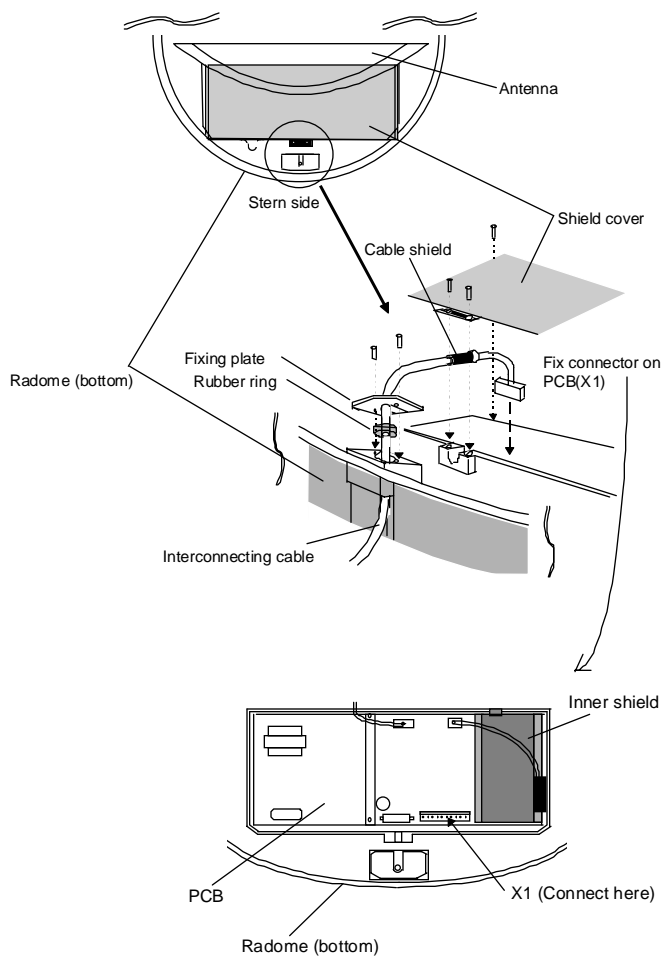

**Fig.3-8-1 Fitting interconnecting cable (RA40C)**

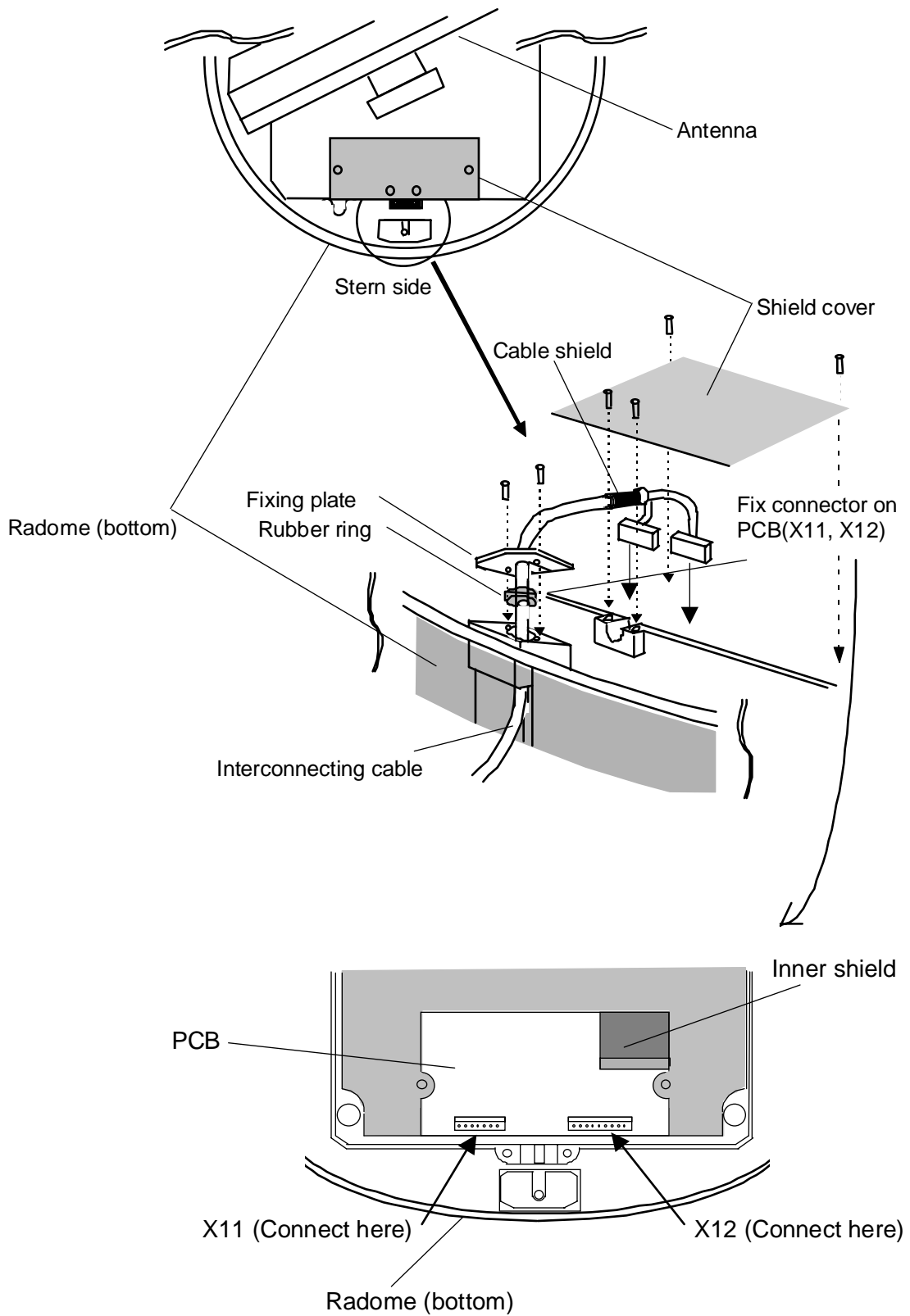

**Fig.3-8-2 Fitting interconnecting cable (RA41C)**

### 3.7.2 Interconnecting cable (RA42C Open scanner) (See Fig.3-9)

- ① Ensure that the radar is off. Connect the cable to the receptacle labeled "SCANNER" on the rear panel of the display unit.
- ② Use a T-wrench to remove the back covers of scanner unit.
- ③ Remove the two bolts securing the transceiver; pull out the transceiver after removing two connectors.(to Motor(X1), to Heading switch (X2))
- ④ Remove the four bolts securing the fixing plate at the cable entrance.
- ⑤ Remove the metal fixing plate, rubber seal and washer that secure the cable. Pass the cable through as shown in the diagram below; replace the above items and tighten the bolts.
- ⑥ Return the transceiver to its original position and secure it with the removed bolts.
- ⑦ Connect 7-pin connector to X11 and 9-pin connector to X12 of PCB. And connect two connector that removed at ③.
- ⑧ Refit the scanner covers.  
Take care not to pinch the cable when refitting the cover.

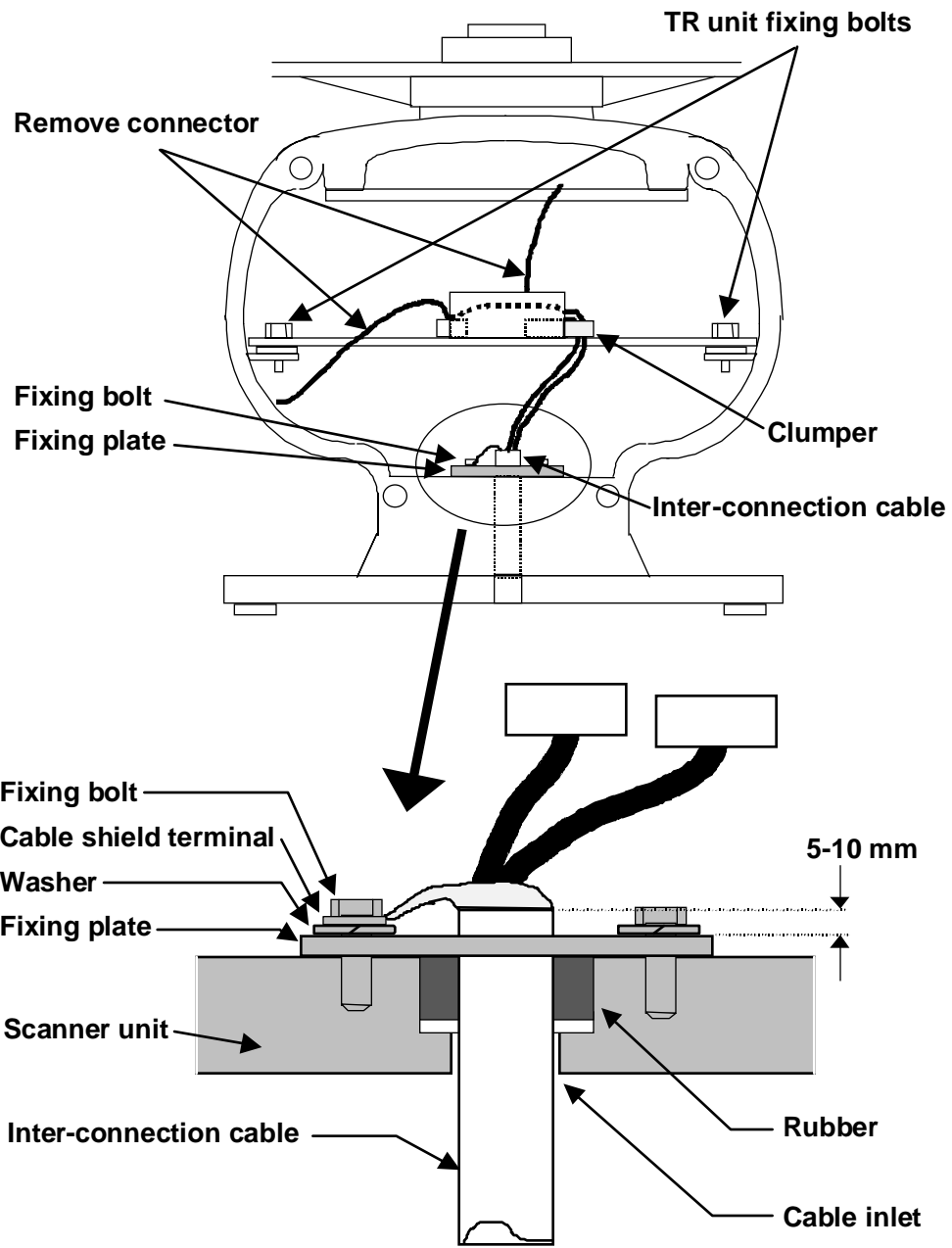
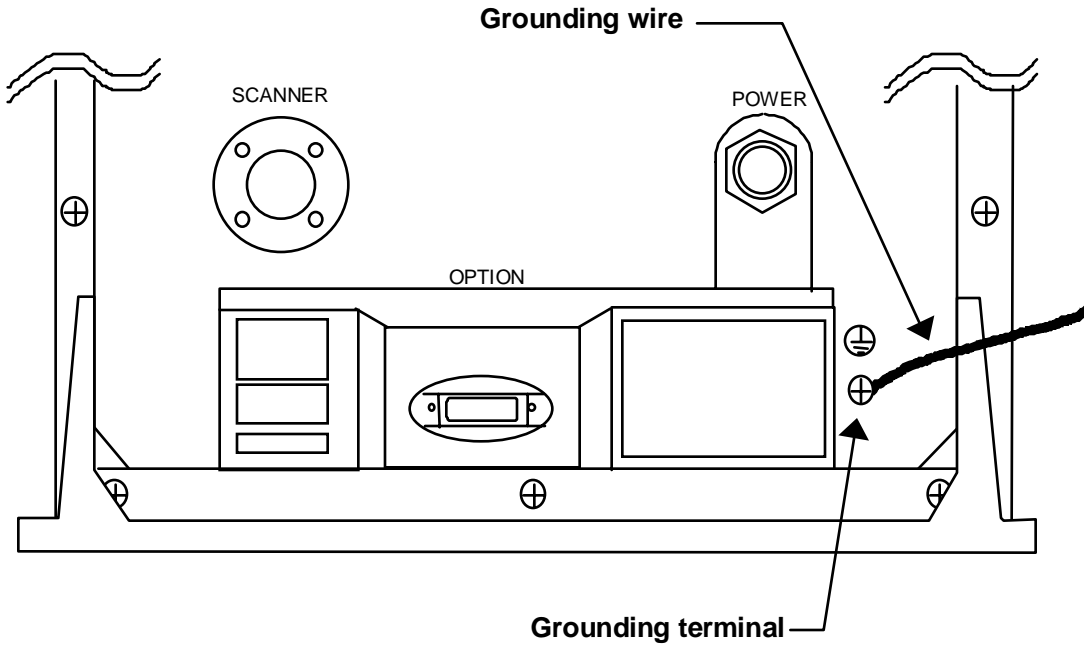

**Fig.3-9 Fitting interconnecting cable**

### 3.7.3 Grounding wire

**⚠ WARNING**  
**Connect grounding wire before connecting power supply cable. Leakage current is too high.**

Connect grounding wire from the grounding terminal on the rear panel of the display unit to the ship's hull as shown below.



**Fig.3-10 Grounding display unit to earth**

Connect grounding wire from one of the bolts you have attached when installing the scanner unit to the ship's hull as shown in Fig.3-11. (The crimp terminal and grounding wire are not included with the radar equipment.)

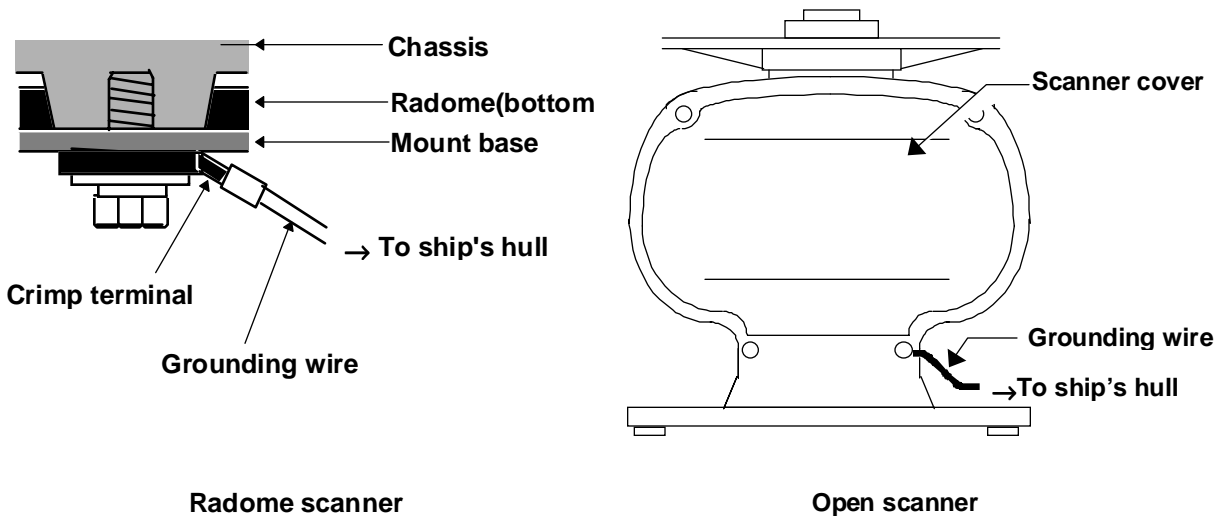

**Fig.3-11 Grounding scanner unit to earth**



### 3.7.4 Power supply cable

Power is fed through a knife switch ( or circuit breaker) and protective fuses, as shown in below.

**WARNING: Do not apply over 41.6V to Radar or Radar may be broken.**

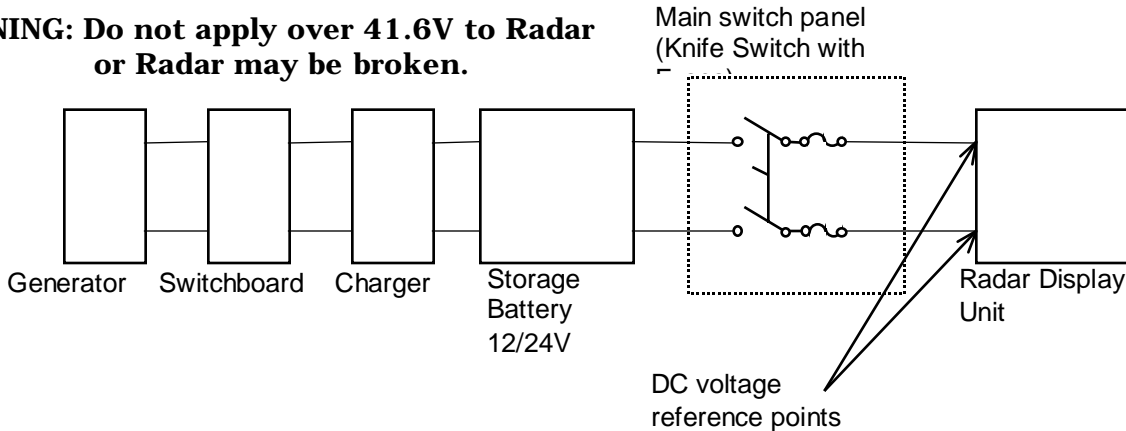

Fit the power supply cable (included with your radar) to the receptacle labeled "POWER" on the rear panel of the display unit. And connect to power supply as followings. (When you do not connect external equipment, put tape on red and green wire.)

Place the Fuse and connection part where there is no water splash and dry area.

When extend the power supply cable, use a suitable cable as below.

Ship's Power Voltage	Cable conductor cross section	Cable max. length
12Vdc	3.5 mm <sup>2</sup>	3 m
	6.0 mm <sup>2</sup>	5 m
24Vdc	2.0 mm <sup>2</sup>	6 m
	3.5 mm <sup>2</sup>	10 m

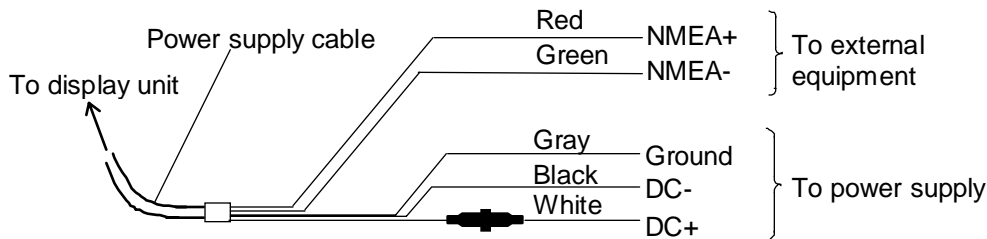

**Fig.3-12 Power supply cable**

### 3.8 Adjustment

**CAUTION**

**Be sure to operate the following adjustment. If this is not adjusted properly, the radar picture does not display true image.**

When you have finished installing the scanner and display units and connecting cables, turn on the power to the display and scanner units and check to see if they operate normally without problem. Then make adjustments as detailed below and check to see if the units operate normally again.

- ① TUNING
- ② HEADING DIRECTION
- ③ DISTANCE

Refer to Adjusting tuning circuit in 5.5.4.5.4  
 Refer to Adjusting angle in 5.5.4.5.4  
 Refer to Adjusting distance in 5.5.4.5.4

### 3.9 Connecting External Equipment to Display Unit

The display unit has two channels of NMEA input. One is standard in power cable. The other is necessary to connect optional parts (Junction box with OPTION cable).

OPTION connector is located at display's rear panel for connecting external equipment such as a GPS, LORAN, or gyro compass. You must have an Junction box with OPTION cable. (Refer to CHAPTER 8 (4) External interface.)

**Note: SIN/COS and MOB signals cannot be used on Junction Box.**

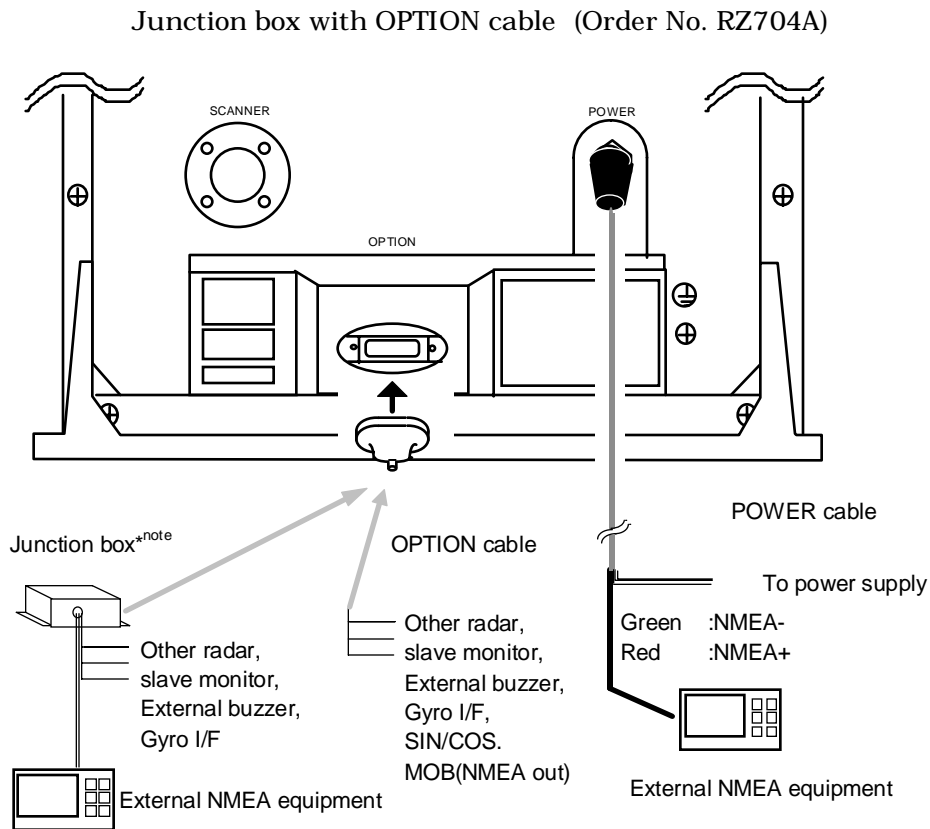

**Fig.3-13 Connecting external equipment to display unit**

### 3.10 Countermeasure for Electromagnetic Interference

RA40C/41C/42C radar provides shields in the units and the inter-unit connection cable. When the radar, however, is closely installed to radio equipment such as VHF transceiver, UHF transceiver, etc., or the radar and/or radio equipment are not sufficiently grounded to the hull or ship's earth, the radar may happen to cause EMI trouble.

Followings are general procedures for reducing EMI due to radars. When installing radars, refer to them, and also check the radio equipment EMI trouble with operating the radar and radio equipment.

(1) Installation Place of Radar

The display unit, scanner unit and inter-unit connection cable should be located apart from the main unit, feeder, antenna coupler and antenna of radio equipment as far as possible.

Especially, proper installation of the feeder, antenna coupler and antenna of radio equipment is very important to improve EMI trouble.

(2) Laying Power Supply Cables

Following connections A and B are recommended to reduce conduction noise generated from radar. Connection C should not be used.

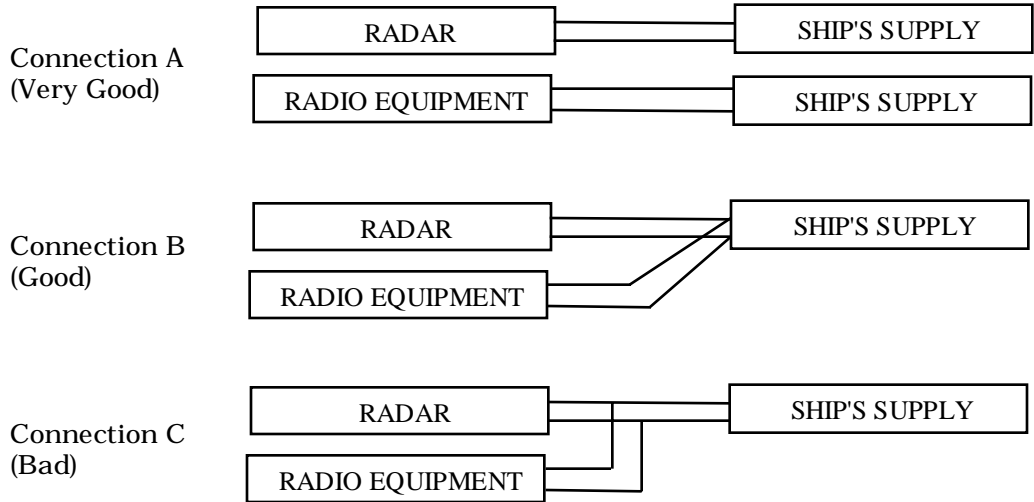

(3) Grounding

All equipment should be firmly grounded at the earth nearest hull with copper plates or braided wires.

**Improvement Procedure for EMI**

- (1) Confirm grounding on the radar and radio equipment. However, some equipment, on which grounding is not always necessarily, have a possibility of EMI improving when taking off their grounding. Try to take off grounding.
- (2) Confirm power supply cable connections and modify to the connection A or B above.
- (3) Try to shift the display unit and inter-unit connection cable of radar to be apart from radio equipment.
- (4) Try to shift the feeder of radio equipment to be apart from each units and the inter-unit connection cable of radar.
- (5) Try to shift the antenna coupler and antenna of radio equipment to be apart from the scanner unit and inter-unit connection cable of radar.

**3.11 When Discarding Your Radar** \_\_\_\_\_

When discarding your RA40C/41C/42C radar, consult the distributor to get information on precautions to be followed. Tab.3-7 below lists the primary component materials of the RA40C/41C/42C radar for your reference.

**Tab.3-7 Component Materials**

Scanner unit	Material	Display unit	Material
Radome	AES	Front panel	ABS
Chassis	A5052P	Rear panel	ADC12
Base	ADC12	Pedestal	ABS+PC
Antenna	A5052P		