

RA40C/RA41C/RA42C Marine Radar Instruction Manual



1st Edition

- Read this manual before using the equipment.

Index

- A**
- Adjustment
 - Distance 75
 - Angle 75
 - Tuning 76
 - Antenna height 77
 - Automatic gain 78
 - Automatic STC 78
 - ALL PPI Screen 64
 - ALL PPI/PPI Screen 65
- B**
- Bearing scale 26
 - Brightness 29
 - Brightness of Panel 29
 - Buzzer 71
- C**
- Changing setting (CUSTOM) 68
 - Continual variable range (VAR RNG) 38,50
 - Course error (XTE) 28
 - Cross cursor (+) 26
- D**
- Display modes (MODE) 38,52
- E**
- EBL 35,46
 - Bearing of EBL (EBL BRG) 71
 - Echo Menu 56
- F**
- False echoes 5
 - FL VRM, FL EBL 36,47
 - FTC 33,57
- G**
- Gain 32,56
 - Guard zone (GZ) 38,53
 - Guard zone mode (GZ MODE) 73
 - Guard zone level (GZ LVL) 73
- H**
- Heading marker 6
 - Heading Off (HDG OFF) 38,49
 - Heading blink (HM FLSH) 71
 - Heading information (HEAD) .. 28
 - Hold (HOLD) 73
- L**
- Language 73
- M**
- Mark Line 51
 - Menu bar 45
 - Man Over Board (MOB) 34
 - MOB Screen 65
 - Monitor operation (DISPLAY) 73
- N**
- Nav (Navigation) Menu 52
 - Navigation screen 28
 - North mark (NORTH M) 6,71
- O**
- Off-center (OFF-C) 39,54
 - Option 87
- P**
- Parallel cursor (///CSR) 38,49
 - PPI Screen 62
 - PPI/NAV Screen 64
 - PPI/PPI Screen 63
 - PPI/SEMI3D Screen 63
 - Pulse table (P TABLE) 71
- R**
- Radar interference 6
 - Radar screen 26,27
 - Range 31
 - Range rings (RINGS) 38,50
 - Range ring interval 50
 - Reverse screen 42,66
- S**
- Semi-3D 43,63
 - Sleep (SLEEP) 54
 - Speed (SPEED, SPD SET) 73
 - ST'BY 29
 - ST'BY NAV screen 71
 - STC 32,57
 - Stern marker (STERN M) 71
 - Stretch (ST) 41,58
 - Switching the screen (SEL WIN) 42,65
 - System check 66
- T**
- Target (TARGET) 51
 - Track (TRACK) 41,58
 - Tune 40,57
 - Tune meter 26
- V**
- VAR RNG 38,50
 - VRM 35,47
 - Unit of VRM (RM UNIT) 71
- W**
- Way point (WAYP) 28
 - Bearing of Way point (WP BRG) ... 71
- X**
- XTE 28,44
- Z**
- Zoom (ZOOM) 41,59

Safety Symbols

To prevent the risk of personal injury or damage to the equipment, the following safety symbols are used to indicate safety-related information. Insure that you clearly understand the meanings of the symbols BEFORE using the equipment.

Symbols Used in Manual



DANGER

This indicates a very dangerous procedure that could result in serious injury or death if not performed properly.



WARNING

This indicates a hazardous procedure that could result in serious injury or death if not performed properly.



CAUTION

This indicates a hazardous procedure or danger that could result in light-to-severe injury, or that might damage the equipment, if proper precautions are not taken.

Safety Symbols Used on Equipment

The following safety symbols are used inside or on the equipment near operation locations to provide information about safety items and operation precautions. Insure that you clearly understand the meanings of the symbols and take the necessary precautions BEFORE using the equipment.



This indicates high voltages with a risk of serious electric shock if the part is touched. NEVER touch the part with bare hands, etc.



The symbol prohibits the operation shown inside the symbol. (The example in the left prohibits disassembly.)



The symbol indicates that the operation inside the symbol is potentially hazardous. (The example on the left indicates that the plug should be held when disconnecting it from the AC outlet.)



This indicates the ground (earth) terminal. If the equipment cannot be grounded via the power cord, connect this terminal to ground. There is a risk of serious electric shock if the equipment is not grounded.

RA40C/RA41C/RA42C
Marine Radar
Instruction Manual

21st Jul. 2000 (1st Edition)

Document: E-A40C/41C/42C-2-00

	WARNING	/	• •
<ul style="list-style-type: none"> • • • 	<ul style="list-style-type: none"> • SEE INSTRUCTION MANUALS BEFORE CONNECTING POWER. SAFETY INFORMATION IS WRITTEN IN. • EARTH CONNECTION ESSENTIAL BEFORE CONNECTING POWER. YOU MAY GET AN ELECTRIC SHOCK. • DO NOT OPEN THE COVER EXCEPT SERVICE PERSONNEL. HIGH VOLTAGE IS INSIDE. YOU MAY GET AN ELECTRIC SHOCK. 	<ul style="list-style-type: none"> • • • • • • • 	<ul style="list-style-type: none"> • • • • • • •

WARNING for Display Unit ;

- ① See instruction manuals before connecting power. Safety information is written in.
- ② Earth connection essential before connecting supply.
There is a risk of serious electric shock if the equipment is not grounded.
- ③ There is a risk of receiving electric shock if these parts are touched by accident.
Only qualified personnel should remove covers on these parts.

Installation

Radio laws dictate that this radar may only be installed by properly licensed personnel.

Licensing

You must obtain a license as prescribed by the Radio Law to operate this unit.

To Customers

- * To use this equipment effectively, the operation and maintenance procedure in this manual must be followed properly. Note that this equipment is only a navigational instrument having no warrant for navigation safety. Non-execution of fundamental navigation requirements such as the ship location check or lookout is not allowed.
- * If some abnormality occurs in this equipment, immediately turn off the equipment POWER switch and the radar main switch in the power distribution board and notify our maintenance section or dealer.
- * This instrument uses oscillator and LCD backlight. They are easy to be broken. Do not subject the instrument to excessive force or drop it.
- * The mercury (Hg) is used in LCD backlight. When you discard your radar, it is due to laws or regulations of your nations.

Contents

For safety

CHAPTER 1 OVERVIEW	1
1.1 Introduction.....	1
1.2 Organization of This Manual.....	1
CHAPTER 2 USING RADAR FOR THE FIRST TIME.....	2
2.1 What is a radar ?	2
2.2 Characteristics of Radar Wave	3
2.3 Terms Specific to Radars.....	6
CHAPTER 3 INSTALLATION.....	10
3.1 Checking Contents of Your Package.....	10
3.2 Checking Power Supply Voltage.....	11
3.2.1 Power Supply Requirement.....	12
3.2.2 Fuse Replacement	12
3.3 Determining Place of Installation.....	12
3.3.1 Scanner unit.....	12
3.3.2 Display unit	12
3.3.3 Shifting away from obstacles	13
3.4 Installing Scanner Unit	14
3.5 Installing Antenna Unit.....	15
3.6 Installing Display Unit.....	16
3.7 Connecting Cables.....	17
3.7.0 Interconnecting cable (RA40C Radome scanner).....	17
3.7.1 Interconnecting cable (RA41C Radome scanner)	17
3.7.2 Interconnecting cable (RA42C Open scanner).....	20
3.7.3 Grounding wire.....	21
3.7.4 Power supply cable.....	22
3.8 Adjustment	22
3.9 Connecting External Equipment to Display Unit	23
3.10 Countermeasure for Electromagnetic Interference	23
3.11 When Discarding Your Radar.....	24
CHAPTER 4 FUNCTIONS AND NAMES	25
4.1 Key layout	25
4.2 Rear panel.....	26
4.3 Radar screen (Single screen).....	26
4.4 Radar screen (Dual screen).....	27
4.5 Radar screen (All PPI screen)	27
4.6 Radar screen (All PPI/PPI screen).....	28
4.7 Navigation screen	28
CHAPTER 5 OPERATION	29
Basic operation of Radar	29
5.1 Powering On and Off.....	29
5.2 Adjusting brilliance of screen and key-backlight.....	29
5.3 Basic Operations	30

5.3.1 Powering On and Off.....	30
5.3.2 Transmitting	30
5.3.3 Adjusting brilliance of screen and key-backlight.....	31
5.3.4 Changing Distance Range (RANGE UP, RANGE DOWN)	31
5.3.5 Automatic adjustment (AUTO)	31
5.3.6 Sensitivity adjustment (GAIN).....	32
5.3.7 Removing sea clutter (STC).....	32
5.3.8 Removing rain and snow clutter (FTC).....	33
5.3.9 Man Over Board (MOB)	34
5.4 Functions of Soft Keys.....	35
5.4.1 Bearing measurement (EBL1).....	35
5.4.2 Bearing measurement (EBL2).....	35
5.4.3 Distance measurement (VRM1).....	35
5.4.4 Distance measurement (VRM2).....	36
5.4.5 Measuring the angle between two points (FL EBL2).....	36
5.4.6 Measuring the distance between two points (FL VRM2).....	36
5.4.7 Changing the group of Soft Keys(NEXT).....	37
5.4.8 Erasing heading maker temporarily (HDG OFF).....	38
5.4.9 Using parallel cursors (///CSR).....	38
5.4.10 Establishment of the indication of the RANGE RINGS (RINGS).....	38
5.4.11 ON/OFF of variable range function (VAR RNG)	38
5.4.12 Changing display modes (MODE).....	38
5.4.13 Guard Zone (GZ)	38
5.4.14 Off Center (OFF-C).....	39
5.4.15 Setting of the SLEEP function(SLEEP).....	40
5.4.16 Tuning adjustment (TUNE).....	40
5.4.17 Echo expansion (ST)	41
5.4.18 Displaying locus of target (TRACK)	41
5.4.19 Enlarging selected areas (ZOOM)	41
5.4.20 Increasing sensitivity (S/L).....	42
5.4.21 Switching the screen (SEL WIN).....	42
5.4.22 Changing the color of screen (PICTURE).....	42
5.4.23 Change to PPI screen (PPI).....	43
5.4.24 Change to SEMI3D/PPI screen (SEMI3D).....	43
5.4.25 Change to PPI/PPI screen (PPI/PPI).....	43
5.4.26 Change to PPI/NAV screen (PPI/NAV)	44
5.4.27 Change to ALL PPI screen (ALL PPI).....	44
5.4.28 Change to ALL PPI/PPI screen (ALL PPI2).....	44
5.5 MENU Operation.....	45
- List of MENU.....	45
5.5.1 Mark Menu.....	46
5.5.1.1 Bearing measurement (EBL1)	46
5.5.1.2 Determining the distance (VRM1)	47
5.5.1.3 Bearing measurement (EBL2)	47
5.5.1.4 Determining the distance (VRM2)	47
5.5.1.5 Measuring the distance or angle between two points (FL EBL2, FL VRM2)	47
5.5.1.6 Measuring the angle between two points (FL EBL2).....	48
5.5.1.7 Erasing heading maker temporarily (HDG OFF)	49
5.5.1.8 Using parallel cursors (///CSR)	49
5.5.1.9 Establishment of the indication of the RANGE RINGS (RINGS)	50
5.5.1.10 Variable range function (VAR RNG)	50
5.5.1.11 Output the position data of Cursor (TARGET).....	51
5.5.1.12 Follow the Distance and Bearing marker on the cursor (+MK LINE)	51

5.5.2 Nav (Navigation) Menu	52
5.5.2.1 Changing display mode (MODE).....	52
5.5.2.2 Guard Zone (GZ)	53
5.5.2.3 Shifting display in specific direction (OFF-C).....	54
5.5.2.4 Setting of the SLEEP function(SLEEP)	54
5.5.3 Echo Menu.....	56
5.5.3.1 Sensibility adjustment (GAIN)	56
5.5.3.2 Removing sea clutter (STC).....	57
5.5.3.3 Removing rain and snow clutter (FTC).....	57
5.5.3.4 Adjusting receiver tuning (TUNE)	57
5.5.3.5 Echo expansion (ST).....	58
5.5.3.6 Displaying locus of target (TRACK).....	58
5.5.3.7 Enlarging selected areas (ZOOM)	59
5.5.3.8 Increasing sensitivity (S/L)	60
5.5.4 SETUP Menu	61
5.5.4.1 Initiating the screen display (WINDOW).....	61
- Limitation of screen operation.....	62
- Screen modes and Operations	62
(a) PPI Screen	62
(b) PPI/SEMI3D Screen.....	63
(c) PPI/PPI Screen	63
(d) PPI/NAV Screen	64
(e) ALL PPI Screen	64
(f) ALL PPI/PPI Screen.....	65
(g) MOB Screen.....	65
5.5.4.2 Switching screens on PPI/PPI screen (SEL WIN)	65
5.5.4.3 Changing the color of screen (PICTURE)	66
5.5.4.4 Fault Diagnosis by Self Check (SYSTEM CHECK).....	66
5.5.4.5 Changing the content of the setting (CUSTOM)	68
5.5.4.5.1 Changing the settings of soft keys (KEY ASSIGN).....	69
5.5.4.5.2 Changing the content of settings 1(PRESET1)	71
5.5.4.5.3 Changing the content of settings 2 (PRESET2).....	73
5.5.4.5.4 Changing the content of settings (ADJUSTMENT)	75
(1) Adjusting distance (TIMING ADJ)	75
(2) Adjusting angle (HEAD ADJ)	75
(3) Adjusting tuning circuit (TUNING CAL)	76
(4) Adjusting antenna height (ANTENNA).....	77
(5) Setting GAIN circuit (GAIN)	78
(6) Setting STC circuit (STC).....	78
 CHAPTER 6 MAINTENANCE AND INSPECTION.....	 79
 CHAPTER 7 TROUBLESHOOTING.....	 81
7.1 Fault Diagnosis by Self-check.....	81
7.2 Inspecting Each Part	82
 CHAPTER 8 PRODUCT SPECIFICATIONS	 83
8.1 General.....	83
8.2 Scanner Unit.....	85
8.3 Display Unit	85

8.4 External Interface	86
8.5 Standard set.....	87
8.6 Options	87
8.7 External dimensions and weight	87
8.8 External connection and function	87

APPENDIX

1. RA40C GENERAL SYSTEM DIAGRAM	
2. RA41C GENERAL SYSTEM DIAGRAM	
3. RA42C GENERAL SYSTEM DIAGRAM	
4. RA40C INTERCONNECTION DIAGRAM	
5. RA41C/42C INTERCONNECTION DIAGRAM	
6. OUTLINE DRAWING DISPLAY UNIT	
7. RA40C OUTLINE DRAWING SCANNER UNIT	
8. RA41C OUTLINE DRAWING SCANNER UNIT	
9. RA42C OUTLINE DRAWING SCANNER UNIT	
10. FLUSH MOUNT PROCEDURE	
11. INDEX	
RA40C TEMPLATE OF SCANNER MOUNTING HOLES (ACTUAL SIZE)	
RA41C TEMPLATE OF SCANNER MOUNTING HOLES (ACTUAL SIZE)	

CHAPTER 1 OVERVIEW

1.1 Introduction

The RA40C/41C/42C represents a compact, high-performance color marine radar that delivers a peak power output of 2 kW(RA40C) or 4 kW(RA41C/42C) from the antenna and uses an 10-inch color liquid crystal display.

In addition to a microcomputer, it incorporates a video signal processing LSI and a newly developed LSI chip exclusively designed for radars, thus providing versatile functionality and high performance.

Features

1. A thin display unit incorporating a liquid crystal display.
2. Easy operation using only a few keys and menu screens.
3. A position of key and its function can be set in position (Selectable soft function key).
4. Easy operation by the rotary knob.
Gain, STC, FTC, EBLs, VRMs etc. can be controlled by the rotary knob.
5. A short and a long range echo can be seen at a time (Dual range radar).
6. Semi-3D screen display for easy identification of targets in noise.
7. Capable of continuous distance range changes (Continual variable range).
8. Waterproof construction of display allows installation at any desired location.

1.2 Organization of This Manual

This manual provides a wide range of information necessary to operate the RA40C/41C/42C radar ranging from the basic knowledge on radars to the methods of operating, installing, and maintaining the radar. The manual also provides rather detailed technical information on how to adjust video display to obtain clear images. You are requested to read this manual thoroughly from beginning to end in order to understand the various functions of the radar so you can take full advantage of its advanced functions. If you are using a radar for the first time, refer to the basic data on radars in CHAPTER 2.

This manual consists of the following chapters:

USING RADAR FOR THE FIRST TIME	CHAPTER 2
INSTALLATION	CHAPTER 3
FUNCTIONS AND NAMES	CHAPTER 4
OPERATION	CHAPTER 5
INSPECTION AND MAINTENANCE	CHAPTER 6
TROUBLESHOOTING	CHAPTER 7
PRODUCT SPECIFICATIONS	CHAPTER 8

If you are an experienced user of radars, skip CHAPTER 2 and begin from CHAPTER 3.

CHAPTER 2. USING RADAR FOR THE FIRST TIME

This chapter describes basic information on radars and explains technical terms used in radar operation for those who is using a radar for the first time.

2.1 What is a radar ?

A marine radar is one of the navigation equipment installed on a ship. It emits a radio wave in very high frequency called a microwave from its antenna and receives the reflected radio wave from objects on the sea (e.g., other ships, buoys, and lands). The received radio wave is converted into an electric signal which is displayed on a display screen to indicate the presence of such objects. Although it is very difficult to find other ships or the destination coast with human eyes at night or in thick fog, a radar helps you detect objects on the sea helping you avoid danger when sailing. The antenna turns 360 degrees as it radiates waves, allowing you to grasp ambient conditions around your ship at a glance.

The radio wave radiated from the antenna is called a pulse wave and the radar performs transmission and reception alternately. Several hundred to several thousand pulse waves generally are transmitted while the antenna rotates one turn.

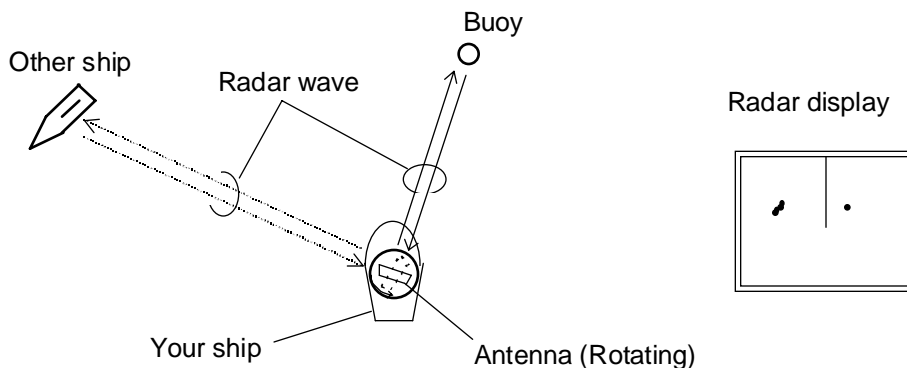

Fig.2-1 What is a radar?

Antenna

There are many types of antennas generally used for a radar. For example, these include a parabolic antenna and a slotted-array antenna. The performance of the antenna determines that of the radar. The dominant factors are the antenna's beam width and side lobe level. The narrower the beam width, the higher the resolution of the angle direction. The lower the side lobe level, the fewer the effect of a false echo.

Side lobe

A beam in one direction in which the strongest radio wave is radiated from the antenna is called the main lobe and beams in other directions are called "side lobes". The side lobe level refers to the difference in level between the largest side lobe and the main lobe.

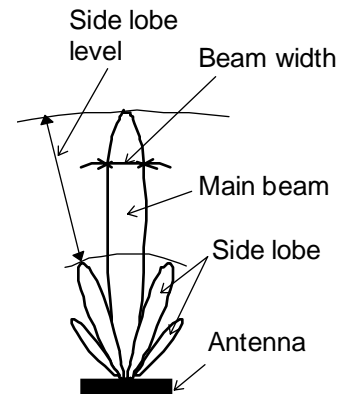

Fig.2-2 Antenna pattern

Beam width

A beam width is defined as the width of the main lobe at an angle where the radiated power is halved as measured from the position from which the strongest radio wave is radiated.

2.2 Characteristics of Radar Wave

Radio waves from the radar propagate while bending slightly along the terrestrial surface. This characteristic varies dependent on the density of the atmospheric air. The sight distance D of a radar generally is said to be approximately 6% longer than the optical sight distance and is calculated using the equation below :

$$D \text{ (NM)} = 2.22 \sqrt{h_1} + \sqrt{h_2} \quad \text{where,} \quad \begin{array}{l} h_1 = \text{antenna height in meters} \\ h_2 = \text{target height in meters} \end{array}$$

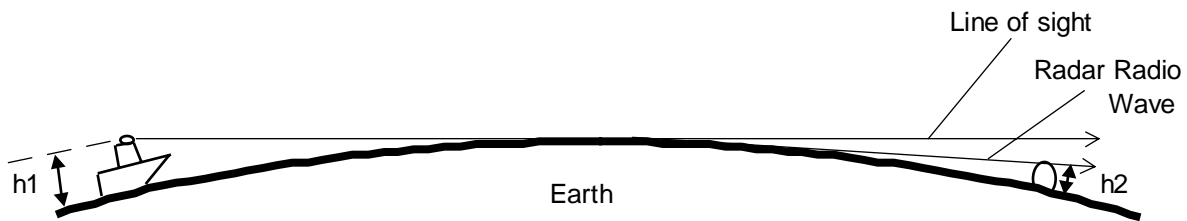

Fig.2-3 Radar wave

Targets difficult to display on screen

The intensity of the reflected wave from a target depends on the distance, height, and size of the target, as well as its material and shape. Targets constructed with FRP, wood, or other low-reflectance materials or those that have a small incident angle are difficult to display on a screen. Therefore, FRP and wooden ships, sandy beaches, and sandy or muddy shallows all are difficult to catch and require attention when monitoring on the screen. Especially, coast lines on the radar image appear to be present more apart from the ship than they are actually located. Therefore, it is important not to misinterpret the available data.

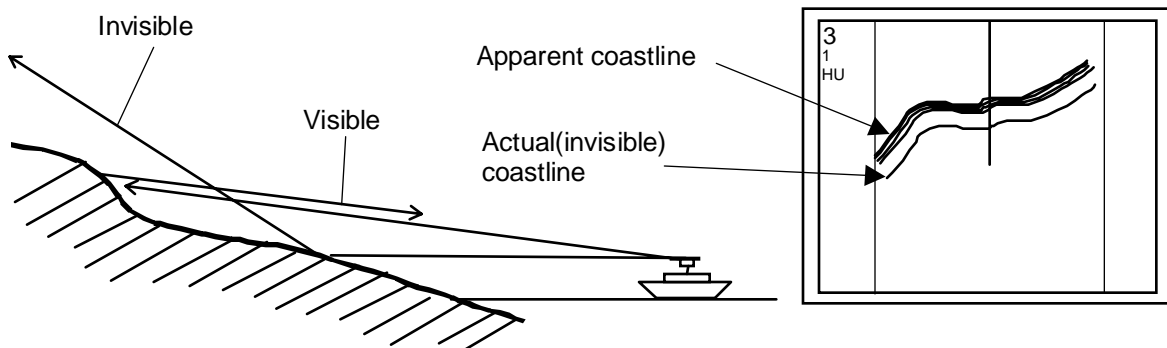

Fig.2-4 Targets difficult to display on screen

Shadow zones of radar

Radar waves are characteristic in that they propagate straight ahead. Therefore, if the ship's smokestack or mast is located near the antenna or there is a tall ship or mountain at the side of the ship, such an object generates a shadow behind it. In this

case, some objects produce a complete shadow and some produce a partial shadow. In an extreme case, the shadow of an object may extend to a position far away and cannot be displayed on the screen at all. Since these shadows can be discovered when installing an antenna, the problem can be avoided by changing the place of antenna installation to minimize the shadow. Targets in shadow zones are difficult to display on the screen.

False echoes

A false echo of an actually nonexistent object may sometimes appear on the screen when sailing. The following explains the cause of each of such phenomena.

A. Ghost echoes

It sometimes happens that one large object near the ship appears at two different bearings. One is the actual echo and other is a ghost echo generated as the wave is re-reflected from the ship's own smokestack or mast. The former appears at the correct distance and bearing on the screen and the latter appears behind the smokestack or mast. This type of false echo is also generated by re-reflection of waves from bridges and quay walls other than the ship itself.

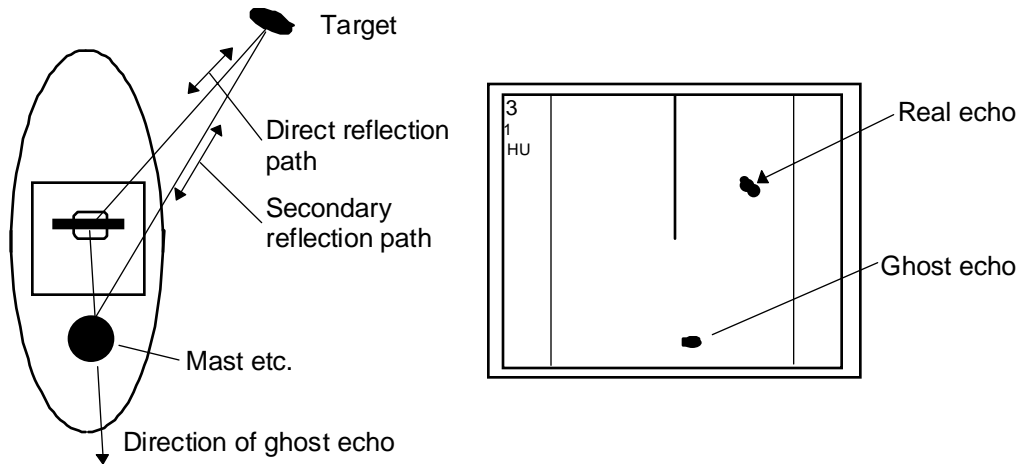

Fig.2-5 False echoes of radar (Ghost echoes)

B. Multiple echoes

If there is a large vertical reflecting plane near the ship as in the case when your ship passes alongside a large ship, the wave is repeatedly reflected back and forth between your ship and the other object. For this reason, two to four images appear on the screen at equal intervals in the same bearing. A false echo that is generated by such multiple reflections is called multiple echoes. In this case, an image appearing at the nearest position is the real echo. Multiple echoes disappear as the ship moves away from the reflecting object or its bearing changes. Therefore, it is not difficult to determine the correct image.

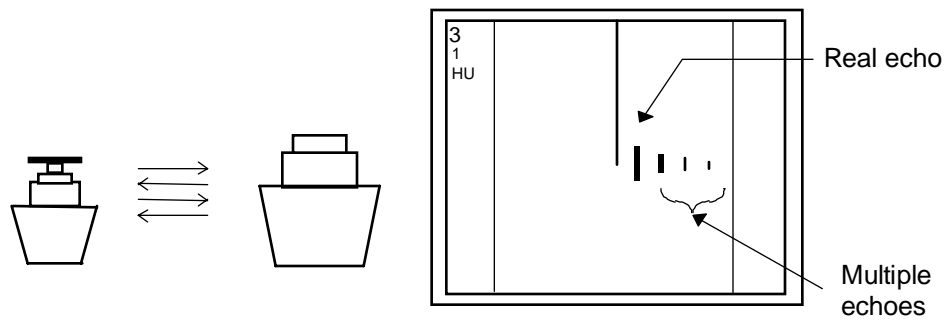

Fig.2-6 False echoes of radar (Multiple echoes)

C. False echoes caused by side lobe

The radiant beam emitted from an antenna contains side lobes in directions other than that of the main beam. Since the side lobe level is low, it in no way affects distant targets. However, if there is a strong reflecting target near the ship, it sometimes appear as a circular-arc false echo on the screen.

⚠ CAUTION

When located near large targets such as land, the ship's mast, etc. sometimes appears as a false echo of circular-arc shape.

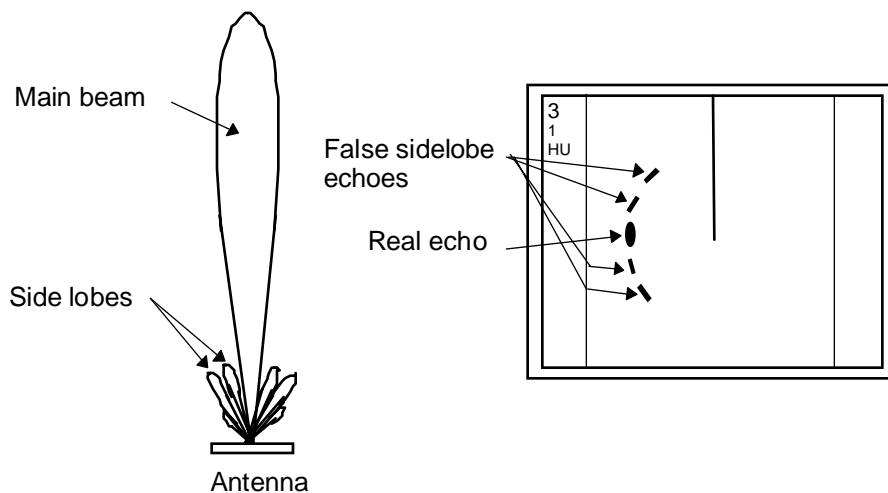

Fig.2-7 False echoes of radar (Caused by side lobe)

D. Distant false echoes caused by duct phenomenon

Depending on meteorological conditions, duct phenomenon sometimes occurs in temperature inverting layers of air. In such a case, the wave propagates erratically reaching a location surprisingly far away from the ship. In this case, a target present at a distant location more than the radar's maximum distance range appears on the screen presenting a false echo that can be misunderstood to be present nearer than the actual position. This phenomenon is attributed to the fact that since echo from the distant target arrives late, it gets out of the pulse repetition frequency and is displayed on the screen as an echo in the next frequency. If the target distance changes as you switch over the distance range, you can determine that it is a false echo.

Radar interference

If a radar operating in the same frequency exists near your ship, interference noise may appear on the screen that is caused by transmitted waves from that radar. This interference appears in various ways. In most cases, however, it appears as spiral or radial patterns.

The RA40C/41C/42C radar has a function to eliminate interference. Use of this function helps you minimize interference.

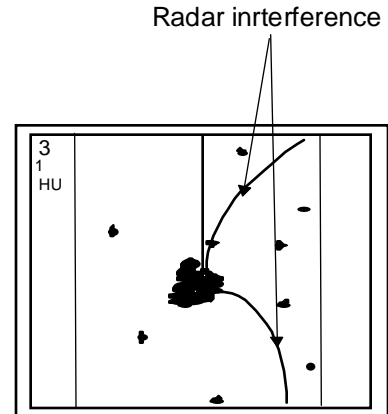

Fig.2-8 Radar interference

2.3 Terms Specific to Radar

HM (Heading Marker)

This is a line-shaped marker used to indicate the advancing direction of your ship.

North Mark

This marker indicates the north direction. It is a short line approximately 1/6 of the screen size.

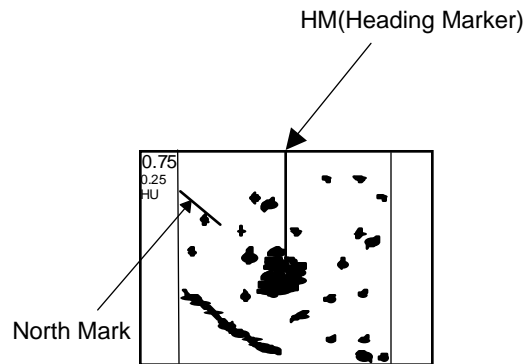

Fig.2-9 Heading Marker and North Mark

Display modes

This refers to a radar's display modes. There are four display modes depending on the direction in which the top of the screen faces with respect to the ship.

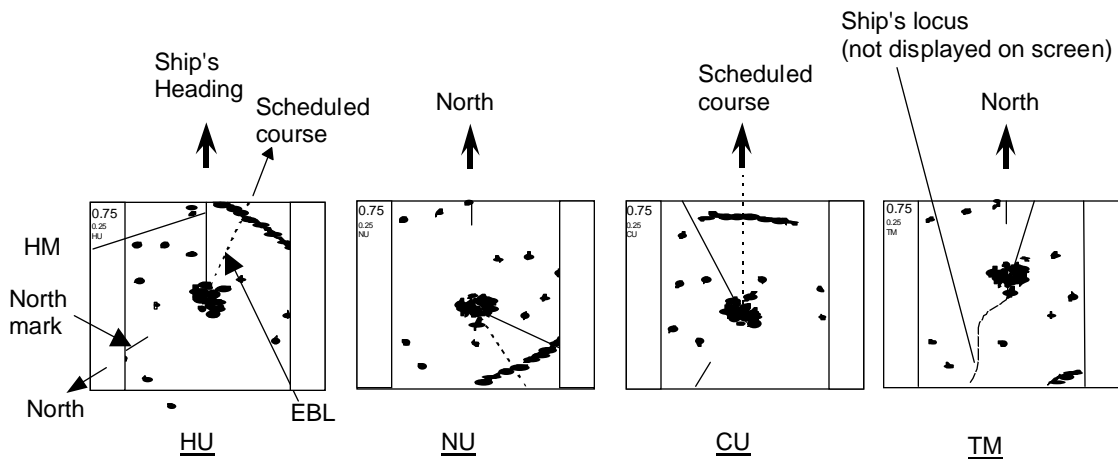

Fig.2-10 Display modes

Head Up (HU)

In this mode, the ship's heading always indicates the upward direction of the screen. This mode lets you know the relative positions of your ship and other ships or land.

North Up (NU)

In this mode, the north direction always indicates the upward direction of the screen, allowing you to compare your ship position with a marine chart as you navigate.

Course Up (CU)

The ship's heading in a course-up mode always indicates the upward direction of the screen as the bearing toward the destination. In this mode, the ship can be maneuvered to sail the shortest distance to the destination by steering it in such a way that its heading marker always directs to the upward direction of the screen. If the ship drifts due to tidal current, care must be taken because the fixed targets move to other positions.

True Motion (TM)

In this mode, the ship is displayed as if it is moving on a marine chart while the fixed targets such as islands and seashores are fixed in position. When the ship reaches a certain position on the screen (approx. 2/3 of screen size), the ship is placed back to the opposite side on the screen. (The top of the screen faces north.)

Note: Navigation equipment such as a gyrocompass or magnet compass must be connected to your radar system before it can be operated in NU, CU, and TM modes. (Refer to Section 3.9 for details on how to connect your radar to navigation equipment.)

VRM (Variable Range Marker)

This is a circular-shaped marker whose size can be changed as desired. You can use this marker when you want to examine the distance of an echo from your ship.

When measuring the distance of an echo from your ship, be sure to measure at a point close to the center of the echo image on the screen.

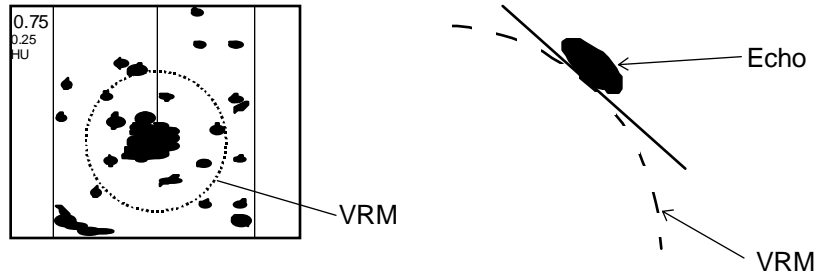

Fig.2-11 VRM

EBL (Electronic Bearing Line)

This is a marker shaped like a straight line segment that can be changed to any direction centering around the ship position. Use this marker to examine the advancing direction of your ship and its relative angle with an echo. When measuring the angle of an echo, position the marker at the center of the echo.

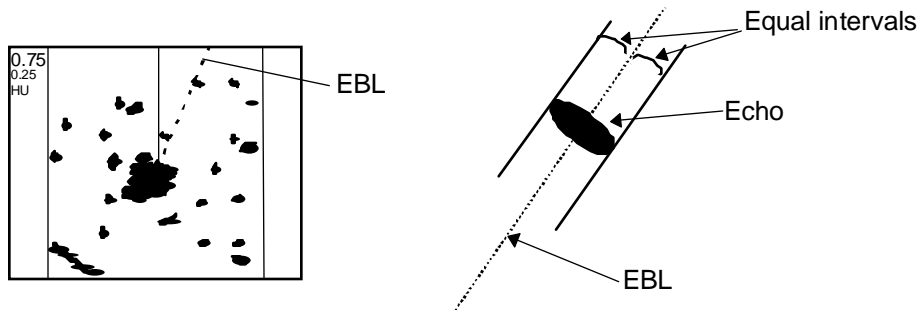

Fig.2-12 EBL

STC (Sensitivity Time Control)

Since echo signals received by the radar are strong when they are coming from a short distance, it is difficult to compare signal strength between each reflected signal. To overcome this difficulty, signal strength is adjusted in such a way that the received signal levels coming from a short distance are lowered and those from a long distance are raised. This function should prove useful when there are large reflected waves from sea surfaces during rough weather.

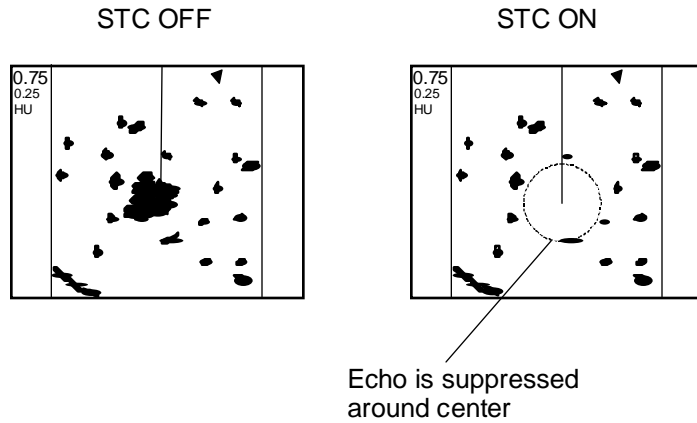

Fig.2-13 STC

FTC (Fast Time Constant)

When it rains or snows, fine noise may appear over the entire screen, making it difficult to identify echoes. In such a case, echo images on the screen can be made easily distinguishable by adjusting FTC.

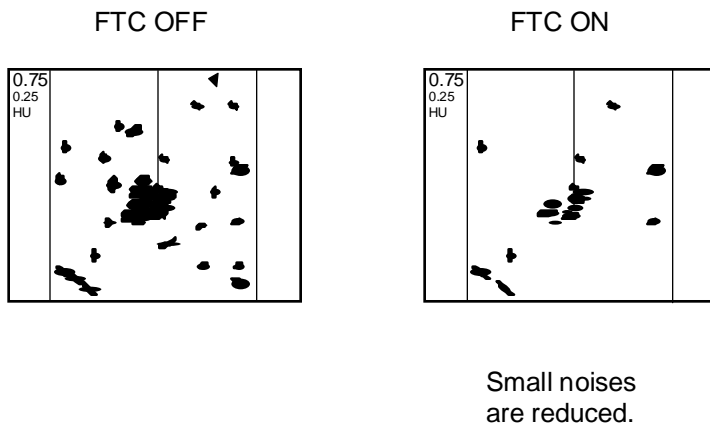
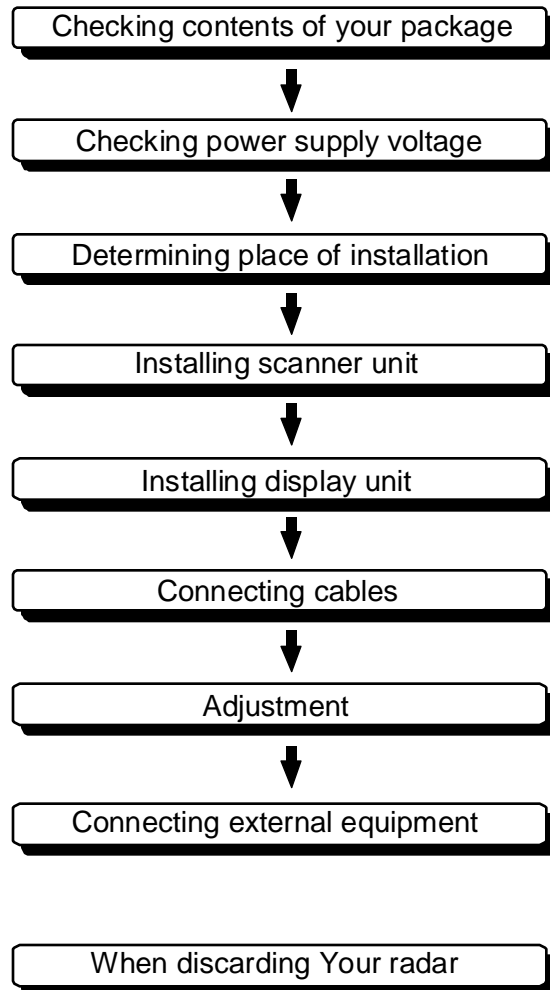

Fig.2-14 FTC

CHAPTER 3. INSTALLATION

This chapter describes procedures for installing the RA40C/41C/42C radar in your ship and precautions to be observed during installation. Follow the procedure below to install the radar.



3.1 Checking Contents of Your Package

First, unpack your package and see if all of the following items are included.

	Item	RA40C Q'TY	RA41C Q'TY	RA42C Q'TY	
(RF719A)	Display unit	1 (RF719A)	1 (RF719A)		1
(RB716A)	Scanner unit	1 (RB714A)	1 (RB715A)		1
	Display cover	1	1		1
	Fuse	2	2		4
	Interconnecting cable	1 (10 m)	1 (10 m)		1 (10 m)
	Power supply cable	1 (2 m)	1 (2 m)		1 (2 m)
	M10 hexagonal bolt	4 sets	4 sets		0
	M12 hexagonal bolt	0	0		4 sets
	Carbon brush	0	0		2

The package contains a 10m interconnecting cable as an accessory. Longer cable is also available as an option as listed in Tab.3-1.

Tab.3-1 Optional Interconnecting Cable

	RA40C	RA41C	RA42C
Cable length	Product No.	Product No.	Product No.
15m	242J160680B	24Y159099B	24Y159169B
20m	242J160680C	24Y159099C	24Y159169C
25m		24Y159099D	24Y159169D
30m	242J160680D		

In addition to the above components included with your package, the following items are also required. Please prepare them separately.

Item	QTY	Remarks
Tapping screw or M5 bolt and nut	6 sets	To install display unit
Grounding wire	1	Earth line for display unit
Grounding wire and crimp terminal	1 set	Earth line for scanner unit

3.2 Checking Power Supply Voltage

3.2.1 Power Supply Requirements

For the RA40C/41C/42C radar to be operated normally, the power supply (battery) detailed in Tab.3-2 is required. Note also that if the battery is discharged, its voltage may fluctuate greatly, causing the radar to malfunction. When start up the radar system or start transmitting, an additional rush current is required on the power line. Carefully check the power supply system including wiring by using a circuit tester.

Tab.3-2 Power Supply Requirements

Supply voltage used	Maximum current	Allowable range of voltage
DC12V	5A	10.2-41.6V
DC24V	2.5A	10.2-41.6V

*A.C. power cannot be used

3.2.2 Fuse Replacement

For the RA40C/41C/42C radar to be operated safely, proper rating fuses must be used. Tab.3.3 and Tab.3.4 are fuse rating tables for RA40C/41C and RA42C. Check them and replace to the fuse in the package.

Tab.3-3 Supply Voltage to Fuse Table for RA40C/41C

Supply voltage used	Main Fuse	Motor Fuse
DC12V	8A/250V or 125V * (6.3• x 32mm)	T3.15A/250V or 125V * (5• x 20mm)
DC24V	8A/250V or 125V (6.3• x 32mm)	T3.15A/250V or 125V (5• x 20mm)

Tab.3-4 Supply Voltage to Fuse Table for RA42C

Supply voltage used	Main Fuse	Motor Fuse
DC12V	10A/250V or 125V (6.3 • x 32mm)	5A/250V or 125V (5 • x 20mm)
DC24V	8A/250V or 125V * (6.3 • x 32mm)	T3.15A/250V or 125V * (5 • x 20mm)

...Note: Marked * fuses are in the set as standard.

3.3 Determining Place of Installation

3.3.1 Scanner unit

A radar's target detection capacity varies greatly depending on the fitted position of the scanner. An ideal fitting position is a location high above the ship's keel line where there is no obstacle all around the scanner. In an actual ship, such an ideal location is limited by various factors. Therefore, consider the following suggestions when you determine the place to install the scanner:

(a) Install scanner at a position as high as possible.

The higher the installation position, the longer the radio ranging distance. Install the scanner at a position as high as possible after considering the ship's hull structure and radar maintainability.

(b) Install scanner away from smoke-stack and mast

If the scanner is installed at the same height as the smoke-stack or mast, radar waves may be blocked, creating shadow zones or generating false echoes. Therefore, do not install the scanner at such a position.

(c) Install scanner forward away from obstacle.

To avoid creating shadow zones or generating false echoes, install the scanner at a position nearer to the ship's bow away from obstacles. When installing the scanner on a mast, position it in front of the mast. (If obstacles cannot be avoided for the ship's structural reasons, refer to "Shifting away from obstacles" described Page 13.)

(d) Do not install the scanner near hot or heat-generating items.

Do not install the scanner at a position where it may be subjected to smoke or hot air from smokestacks or heat from lamps.

(e) Install the scanner away from antennas of other equipment.

Install the scanner as much away from the antennas of a direction finder, radio transceiver, etc. as possible.

 **CAUTION**
**To eliminate the interference, install the scanner
away from the antenna of radio transceivers.**

(f) Make the cable length as short as possible.

Keep the distance from the scanner to the display unit within the standard cable length of 10 m. If you use longer cable for unavoidable reasons, limit the cable length to a maximum of 30 m for RA40C and 100 m for RA41C/42C.

3.3.2 Display unit

The display unit can be installed on desktop, wall surface, or ceiling. Determine the place to install the display unit that is convenient for navigation and radar operation after considering the following suggestions:

- (a) A place where you can see the ship's bow when you raise your face from the radar screen.
- (b) A place where there is no direct sun-light to avoid display temperature up.
- (c) A place where there is good ventilation and minimum vibration.
- (d) A place where the display unit is apart more than the minimum safe distance from a magnet compass as listed in Tab.3-5 below.

Tab.3-5 Minimum Safe Distance from Magnetic Compass

	Master compass	Steering compass
Scanner unit	2.0m	1.4m
Display unit	2.0m	1.4m

3.3.3 Shifting away from obstacles

① Shifting from keel line

By shifting the scanner position from the keel line to the starboard side of the ship, it is possible to move shadow zones to the port side which makes it possible to keep clear vision in the bow direction. The distance to be shifted can be obtained by calculation depending on the distance from the scanner to obstacles using the following equation:

$$L_s = 0.4R + D/2 \text{ [m]} \quad (\text{when } R < 15\text{m})$$

$$L_s = 0.025R + D/2 \text{ [m]} \quad (\text{when } R \geq 15\text{m})$$

where L_s = distance to be shifted from keel line
 D = diameter of obstacle on keel line
 R = distance from scanner to obstacle

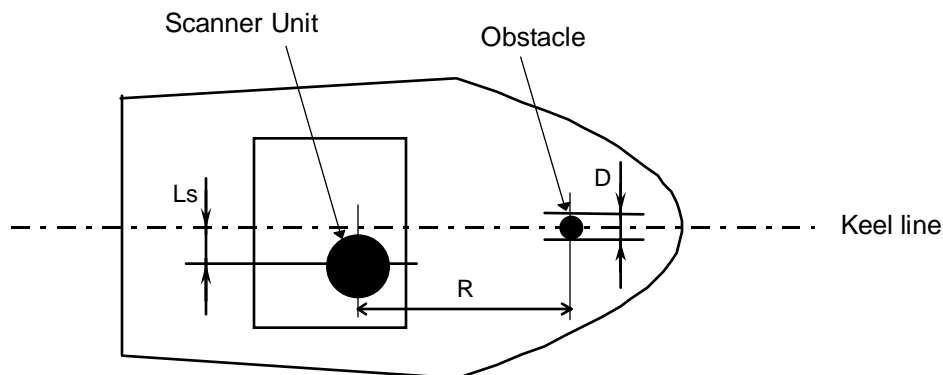

Fig.3-1 Shifting from keel line

② Obtaining sufficient dip angle

Raise the scanner position so that there is a sufficient dip angle θ available between the line of sight from the scanner to the obstacle and the horizontal line. By raising the dip angle above 5° , it is possible to prevent mid- and long-distance shadow zones. The radar cannot detect objects below the line of sight.

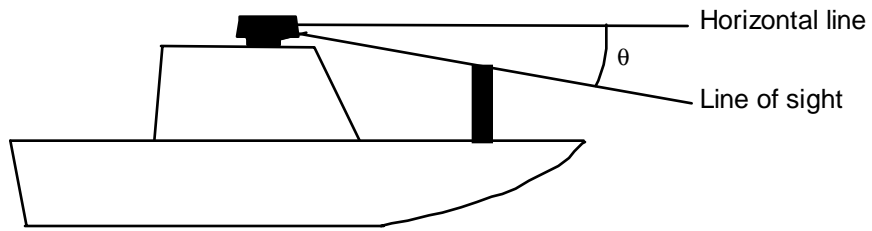

Fig.3-2 Obtaining sufficient dip angle

3.4 Installing Scanner Unit

When you have decided the place of installation, install the scanner unit. If a mount base like the one shown below is available, it may be easier to install the scanner. If such a mount base is not available in your ship, you may install the scanner directly to the roof, etc. In such a case, pay attention to the water drain tube located at the bottom of the scanner unit during installation.

Note : When the radar mast or mounting bracket has a curvature of more than 2mm, repair it or use spacers.

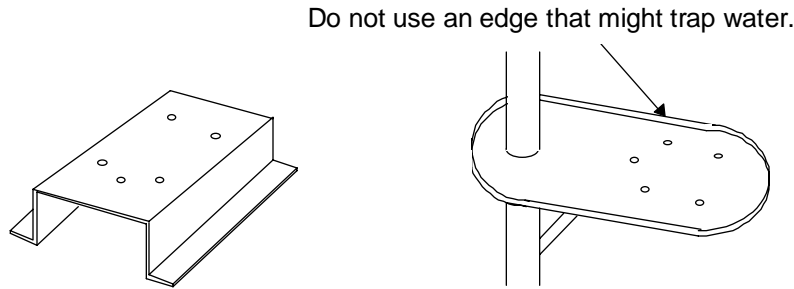

Fig.3-3 Mount base

Referring to Fig.3-4, open holes in diameter of 12 mm (0.47 in.) at five locations in the mount base and use these holes to fix the scanner unit to the mount base with hexagonal bolts. (Use the template included with this manual.) The bolts included with your radar equipment will suffice for mount base thickness of 9 to 14 mm (0.35 to 0.55 in.). If the mount base is thicker or thinner than this, prepare bolts listed in Tab.3-6.

Use sealing of silicon when you prevent the bolts from becoming loose. Radome may be broken if you use locking putty.

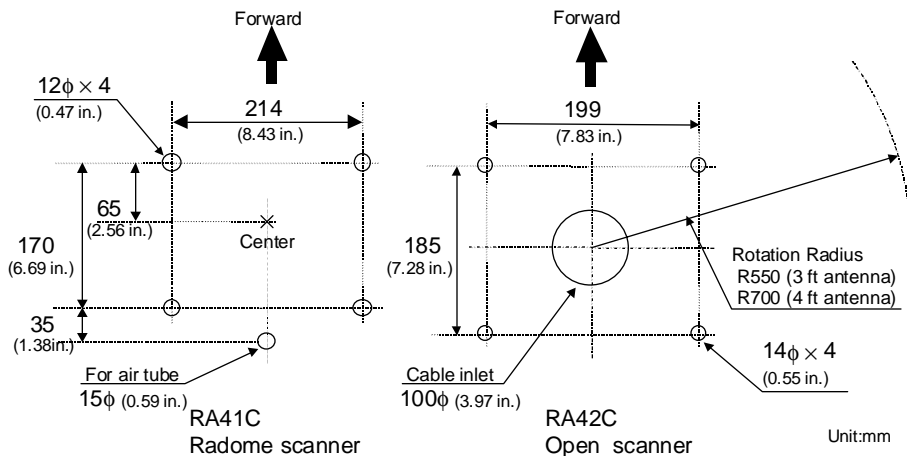
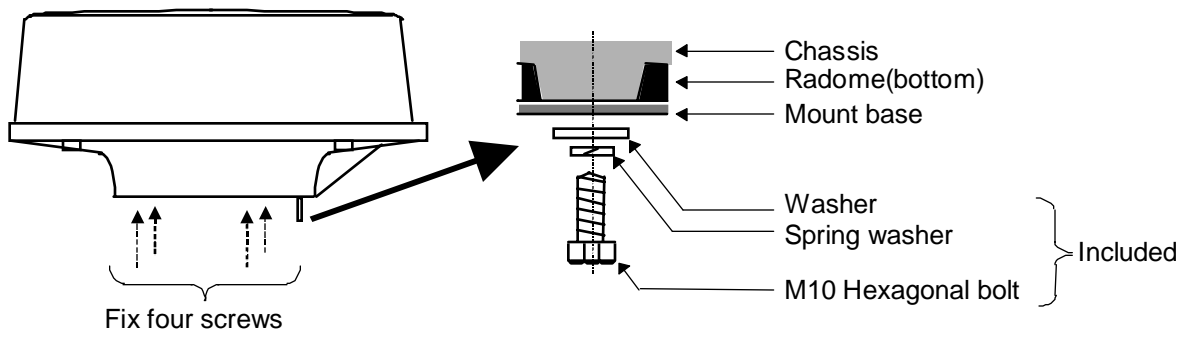
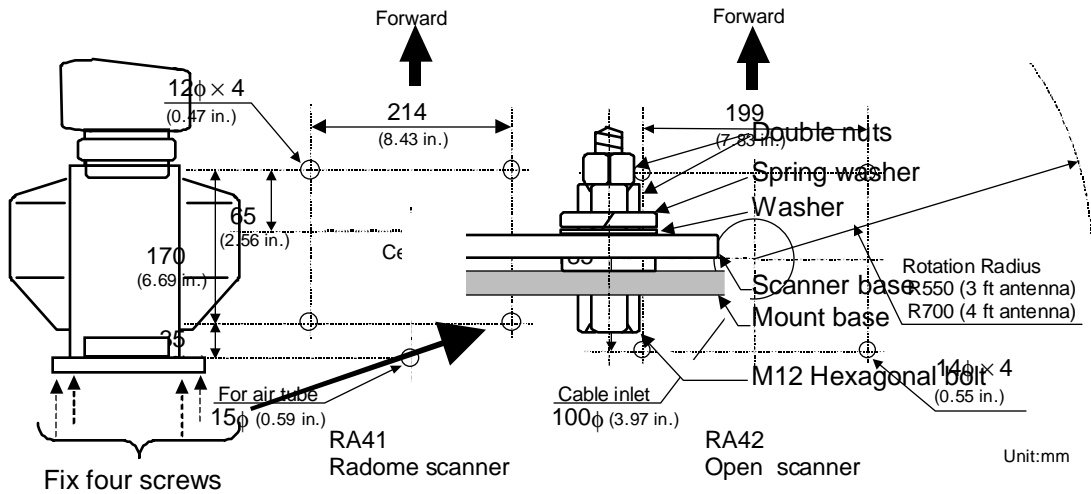

Fig.3-4 Hole positions for mounting scanner



RA40C/41C Radome scanner



RA42C Open scanner

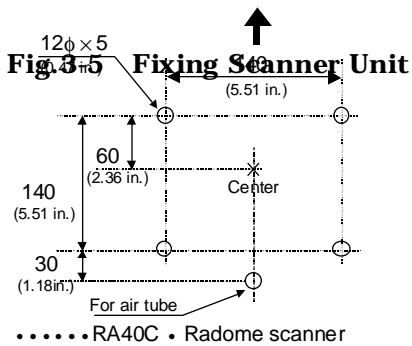

Tab.3-6 Bolts for Mounting Scanner Unit

Thickness of mount base	Bolts necessary to fix radome scanner	Material	Remarks
1-4mm(0.04-0.16 in.)	M10/M12 × 15 (1.5mm pitch)	Stainless	
4-9mm(0.16-0.35 in.)	M10/M12 × 20 (1.5mm pitch)	Stainless	
9-14mm(0.35-0.55 in.)	M10/M12 × 25 (1.5mm pitch)	Stainless	Included with radar
14-19mm(0.55-0.75 in.)	M10/M12 × 30 (1.5mm pitch)	Stainless	

3.5 Installing Antenna Unit

Remove the protective cap covering the rotary coupler on the top of the scanner. Match the antenna radiation direction to direction of the arrow markings on the rotation base and fix the antenna in position using the four M8 accessory bolts.

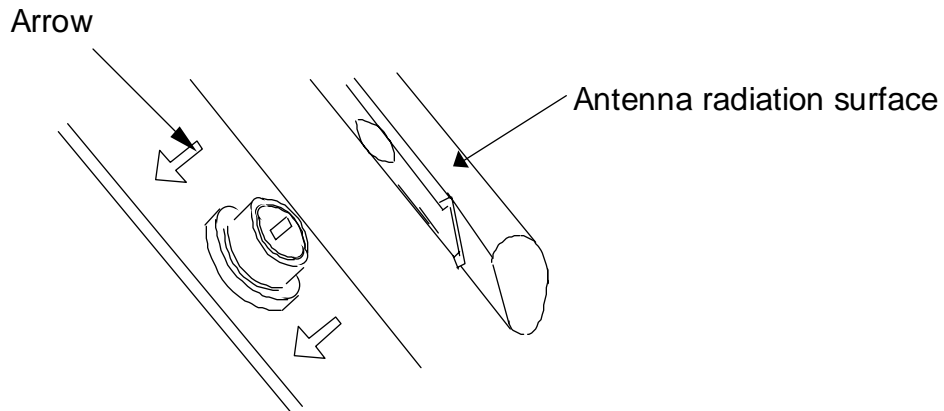

3.6 Installing Display Unit

After you have finished installing the scanner unit, install the display unit in the same way. Choose the proper bolt length according to the thickness of the surface on which you are going to install the display unit. Hole diameter is different using bolts from using tapping screw. When using tapping screw, open holes in adequate holes. When using bolts and nuts, open holes in diameter of 6 mm (0.24 in.). When you have opened holes, install the pedestal part first and then the display unit.

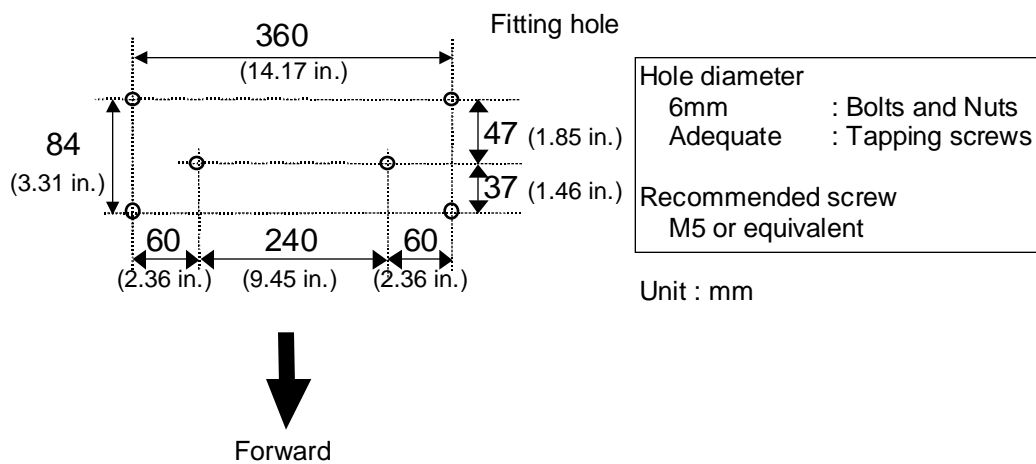

Fig.3-6 Hole positions for display unit

Note : When you install the display by flush mount, refer to appendix "OUTLINE DRAWING". Slide off four triangle corner cover, and fix the display unit to the panel with screws. After fixing the display unit, put on corner covers to the corner of the display unit. See APPENDIX.

 **WARNING**

Avoid a display from operating under direct sunlight. It becomes high temperature at inside of display and display may be broken.

3.7 Connecting Cables

Lay cables firmly in place by following the instructions below.

- Note1: Do not bind the cable for the radar collectively with cables of other equipment (especially power supply cable).
- Note2: Leave clearance near the inlet of the display so you can remove the display unit easily. This facilitates installation and maintenance of the display unit. (Refer to Appendix.)
- Note3: Because the cable has a connector fitted on the display and scanner side, if it is necessary to pass cable through a narrow path, fix the scanner-side connector vertically using vinyl tape before passing cable through the path.
- Note4: Lay cable along the ship's hull or wall surface and attach it in place at intervals of about 40 cm.

3.7.0 Interconnecting cable (RA40C Radome scanner) (See Fig.3-8-1)

- ① Ensure that the radar is off. Connect the cable to the receptacle labeled "SCANNER" on the rear panel of the display unit.
 - ② Next, remove the upper part of the radome from the scanner unit. Avoid bumping it against the antenna by lifting vertically. (There are three fixing screws.)
 - ③ Remove the tape fixing the antenna.
 - ④ Remove the shield cover located on the astern side. (There are three fixing screws.)
 - ⑤ Remove the cable clamping plate and rubber ring, pass cable through the introduction opening, put the rubber ring from both ends of it, and clamp the cable to the scanner unit with screws via the fixing plate. Plug the connector fitted to the cable into the X1 connector on the PCB.
 - ⑥ Replace the aluminum cover. At this time, attach a cable shield onto a ditch with the aluminum cover. However, be careful that the cable will not be caught up between the main unit and cover.
- ⑦ Replace the upper part of the radome. Be careful not to bump it against the antenna in the same way as when removing it. Make sure that the cover is fitted in the correct direction as shown in Fig.3-7-1. The upper and lower parts of the radome each have three markings indicating screw positions. Align the upper and lower positions as you mount the radome.

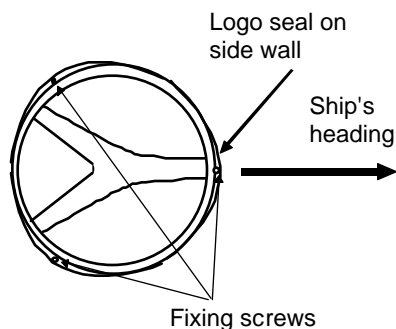

Fig.3-7-1 Fitting Cover (RA40C)

3.7.1 Interconnecting cable (RA41C Radome scanner) (See Fig.3-8-2)

- ① Ensure that the radar is off. Connect the cable to the receptacle labeled "SCANNER" on the rear panel of the display unit.
- ② Next, remove the upper part of the radome from the scanner unit. Avoid bumping it against the antenna by lifting vertically. (There are four fixing screws.)
- ③ Remove the tape fixing the antenna.

- ④ Remove the shield cover located on the astern side. (There are four fixing screws.)
- ⑤ Remove the cable clamping plate and rubber ring, pass cable through the introduction opening, put the rubber ring from both ends of it, and clamp the cable to the scanner unit with screws via the fixing plate. Connect 7-pin connector to X11 and 9-pin connector to X12 of PCB.
- ⑥ Replace the aluminum cover. At this time, attach a cable shield onto a ditch with the aluminum cover. However, be careful that the cable will not be caught up between the main unit and cover.
- ⑦ Replace the upper part of the radome. Be careful not to bump it against the antenna in the same way as when removing it. Make sure that the cover is fitted in the correct direction as shown in Fig.3-7-2. The upper and lower parts of the radome each have four markings indicating screw positions. Align the upper and lower positions as you mount the radome.

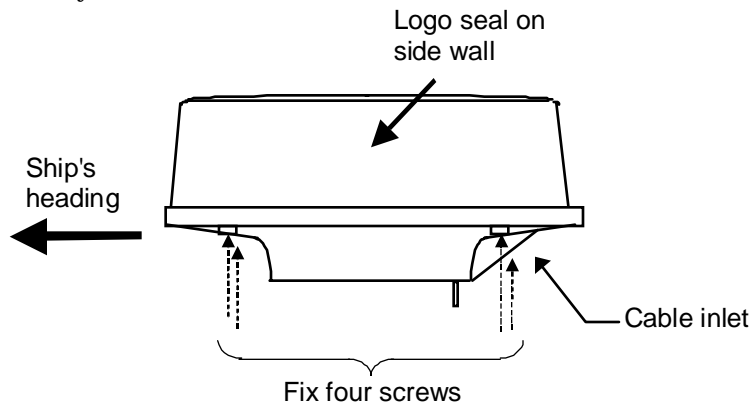

Fig.3-7-2 Fitting cover (RA41C)

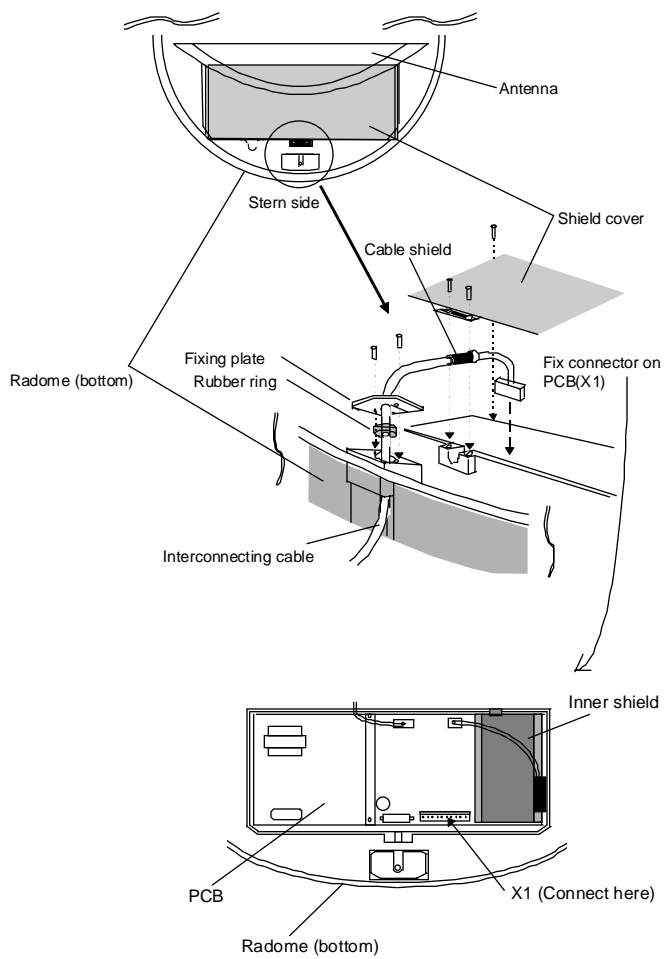

Fig.3-8-1 Fitting interconnecting cable (RA40C)

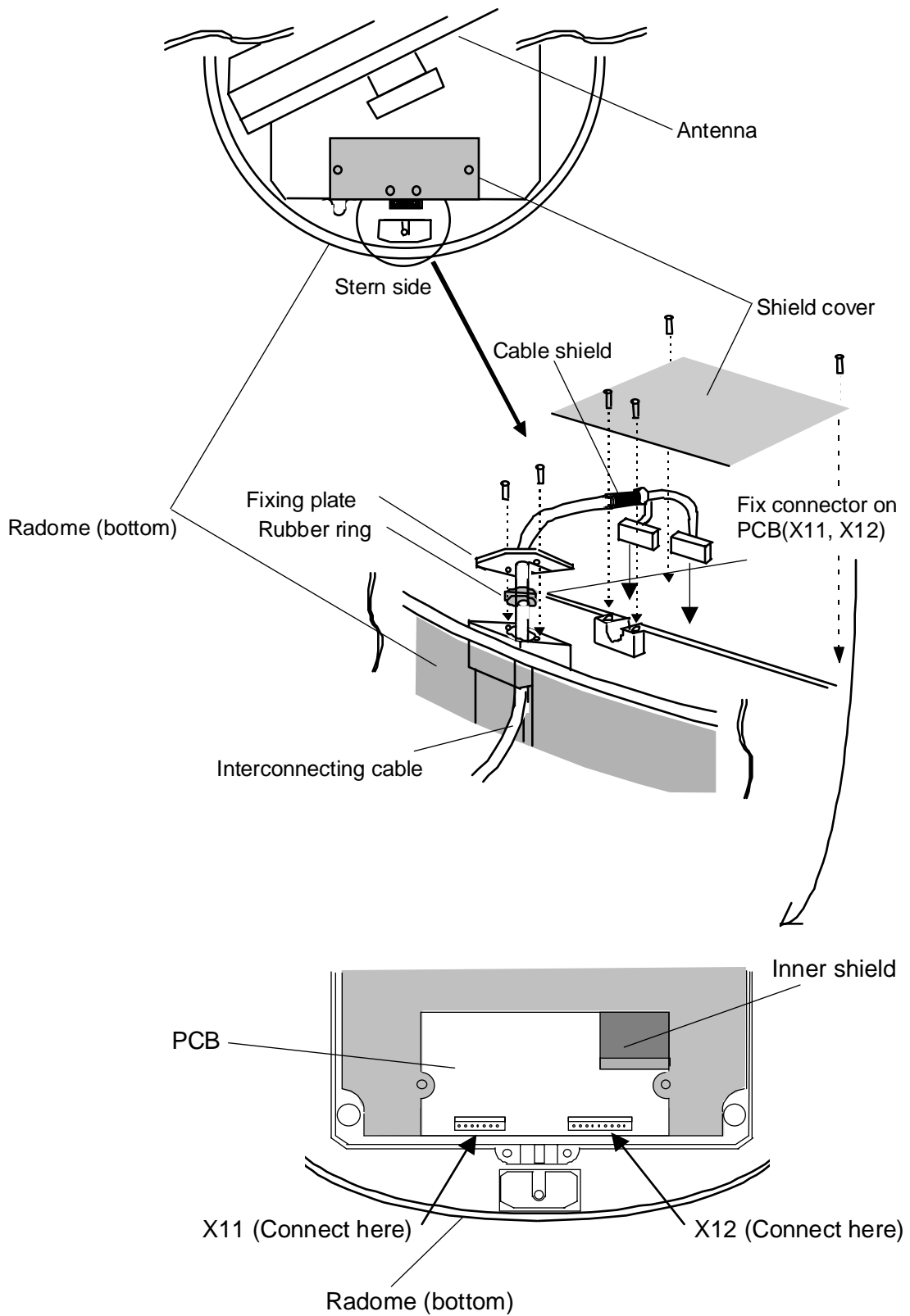

Fig.3-8-2 Fitting interconnecting cable (RA41C)

3.7.2 Interconnecting cable (RA42C Open scanner) (See Fig.3-9)

- ① Ensure that the radar is off. Connect the cable to the receptacle labeled "SCANNER" on the rear panel of the display unit.
- ② Use a T-wrench to remove the back covers of scanner unit.
- ③ Remove the two bolts securing the transceiver; pull out the transceiver after removing two connectors.(to Motor(X1), to Heading switch (X2))
- ④ Remove the four bolts securing the fixing plate at the cable entrance.
- ⑤ Remove the metal fixing plate, rubber seal and washer that secure the cable. Pass the cable through as shown in the diagram below; replace the above items and tighten the bolts.
- ⑥ Return the transceiver to its original position and secure it with the removed bolts.
- ⑦ Connect 7-pin connector to X11 and 9-pin connector to X12 of PCB. And connect two connector that removed at ③.
- ⑧ Refit the scanner covers.
Take care not to pinch the cable when refitting the cover.

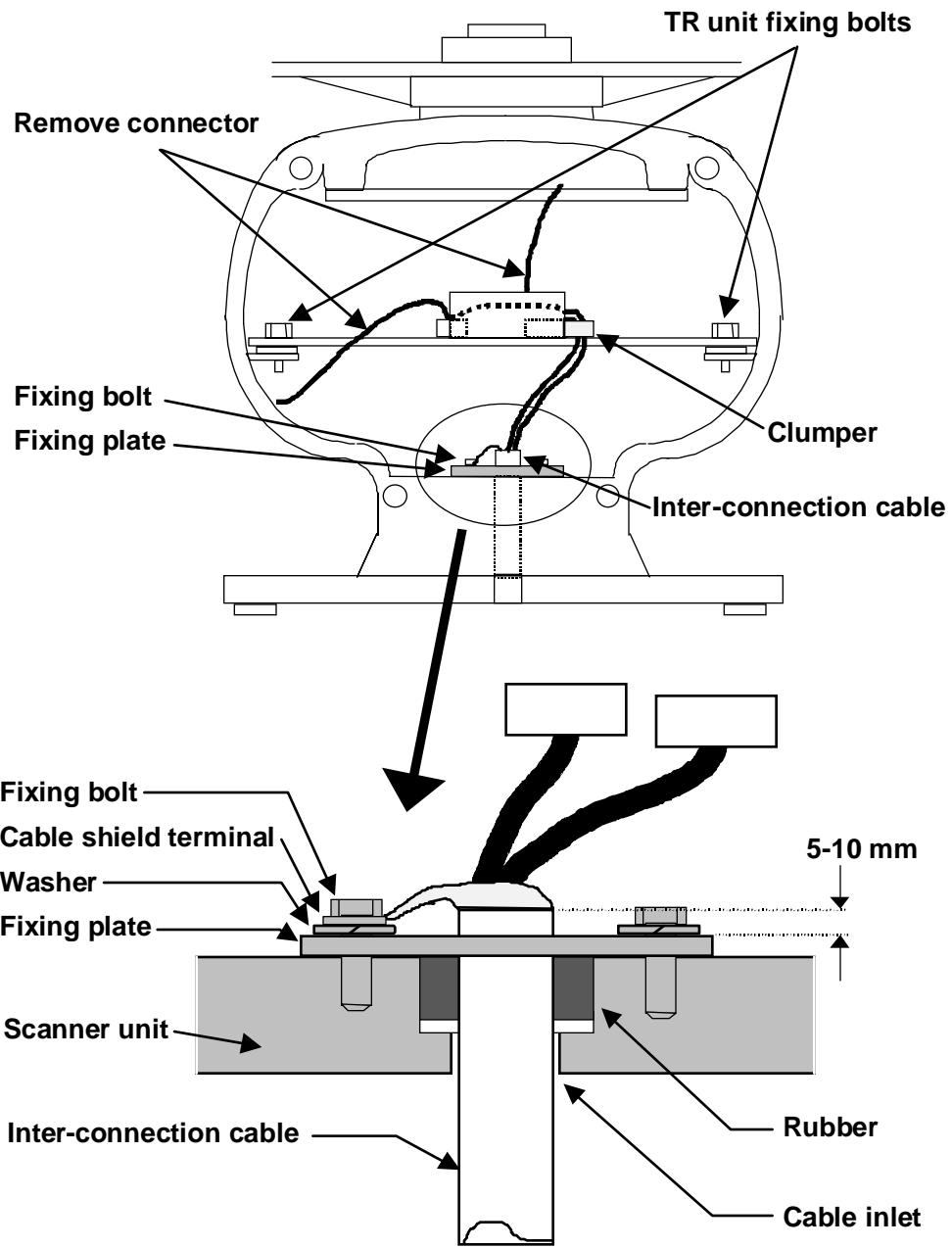

Fig.3-9 Fitting interconnecting cable

3.7.3 Grounding wire

⚠ WARNING
Connect grounding wire before connecting power supply cable. Leakage current is too high.

Connect grounding wire from the grounding terminal on the rear panel of the display unit to the ship's hull as shown below.

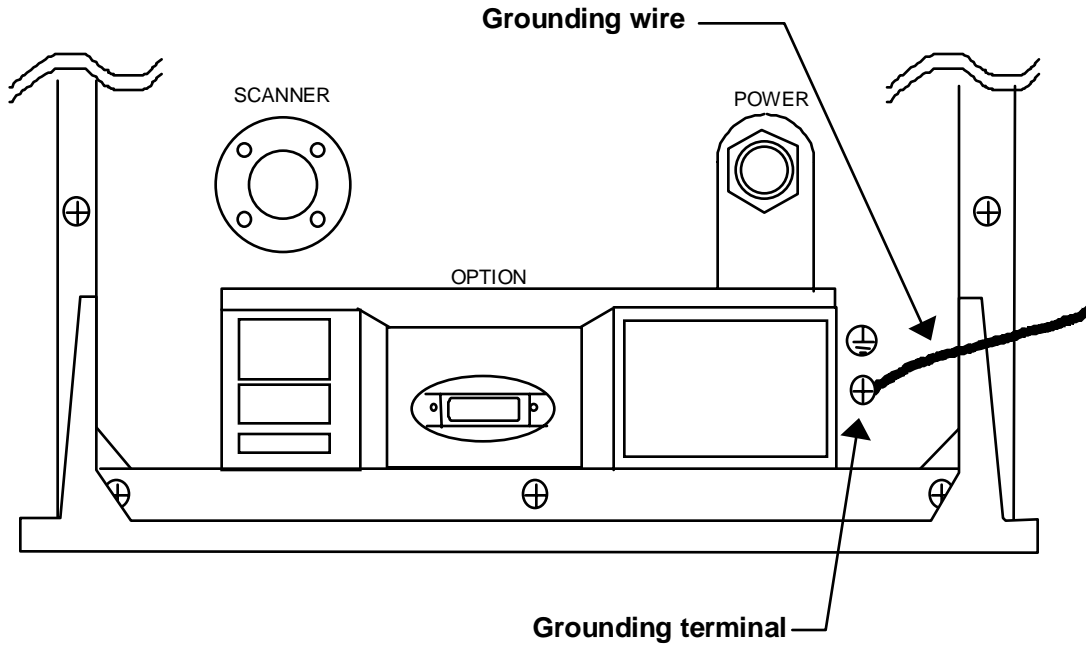

Fig.3-10 Grounding display unit to earth

Connect grounding wire from one of the bolts you have attached when installing the scanner unit to the ship's hull as shown in Fig.3-11. (The crimp terminal and grounding wire are not included with the radar equipment.)

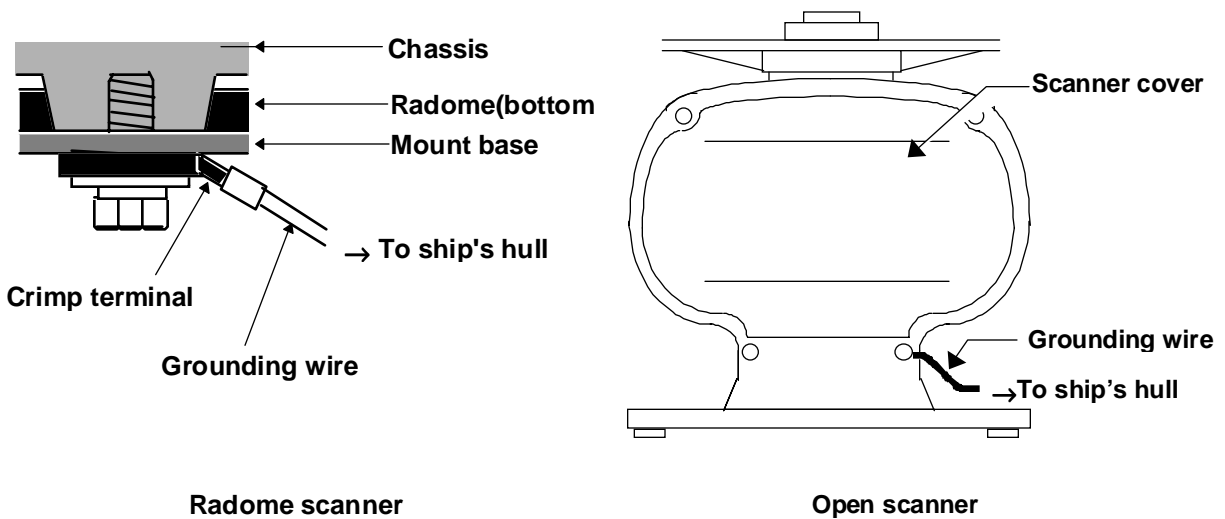
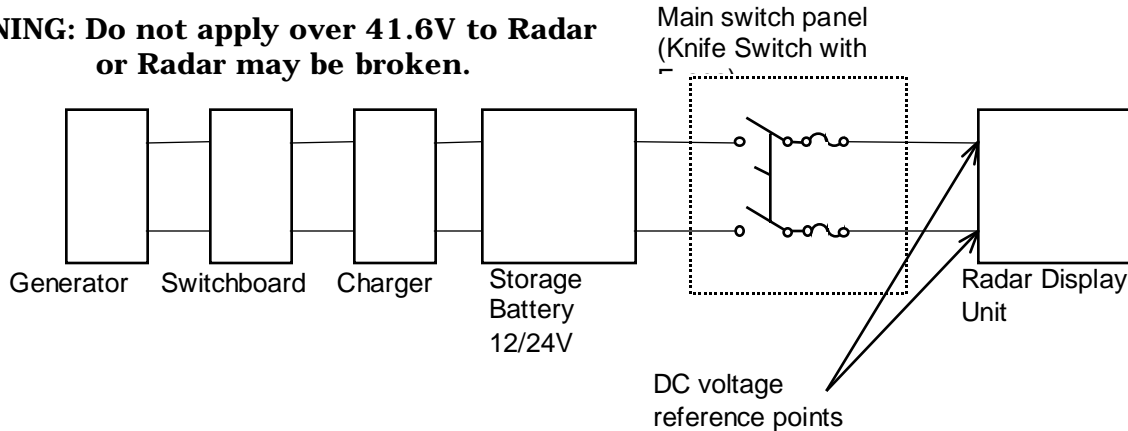

Fig.3-11 Grounding scanner unit to earth

3.7.4 Power supply cable

Power is fed through a knife switch (or circuit breaker) and protective fuses, as shown in below.

WARNING: Do not apply over 41.6V to Radar or Radar may be broken.



Fit the power supply cable (included with your radar) to the receptacle labeled "POWER" on the rear panel of the display unit. And connect to power supply as followings. (When you do not connect external equipment, put tape on red and green wire.)

Place the Fuse and connection part where there is no water splash and dry area.

When extend the power supply cable, use a suitable cable as below.

Ship's Power Voltage	Cable conductor cross section	Cable max. length
12Vdc	3.5 mm ²	3 m
	6.0 mm ²	5 m
24Vdc	2.0 mm ²	6 m
	3.5 mm ²	10 m

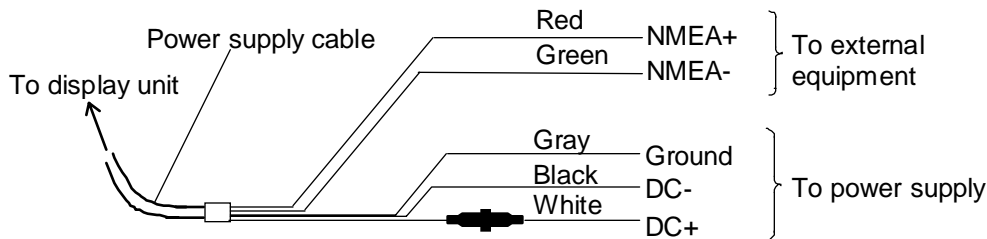

Fig.3-12 Power supply cable

3.8 Adjustment

CAUTION

Be sure to operate the following adjustment. If this is not adjusted properly, the radar picture does not display true image.

When you have finished installing the scanner and display units and connecting cables, turn on the power to the display and scanner units and check to see if they operate normally without problem. Then make adjustments as detailed below and check to see if the units operate normally again.

- ① TUNING
- ② HEADING DIRECTION
- ③ DISTANCE

Refer to Adjusting tuning circuit in 5.5.4.5.4
 Refer to Adjusting angle in 5.5.4.5.4
 Refer to Adjusting distance in 5.5.4.5.4

3.9 Connecting External Equipment to Display Unit

The display unit has two channels of NMEA input. One is standard in power cable. The other is necessary to connect optional parts (Junction box with OPTION cable).

OPTION connector is located at display's rear panel for connecting external equipment such as a GPS, LORAN, or gyro compass. You must have an Junction box with OPTION cable. (Refer to CHAPTER 8 (4) External interface.)

Note: SIN/COS and MOB signals cannot be used on Junction Box.

Junction box with OPTION cable (Order No. RZ704A)

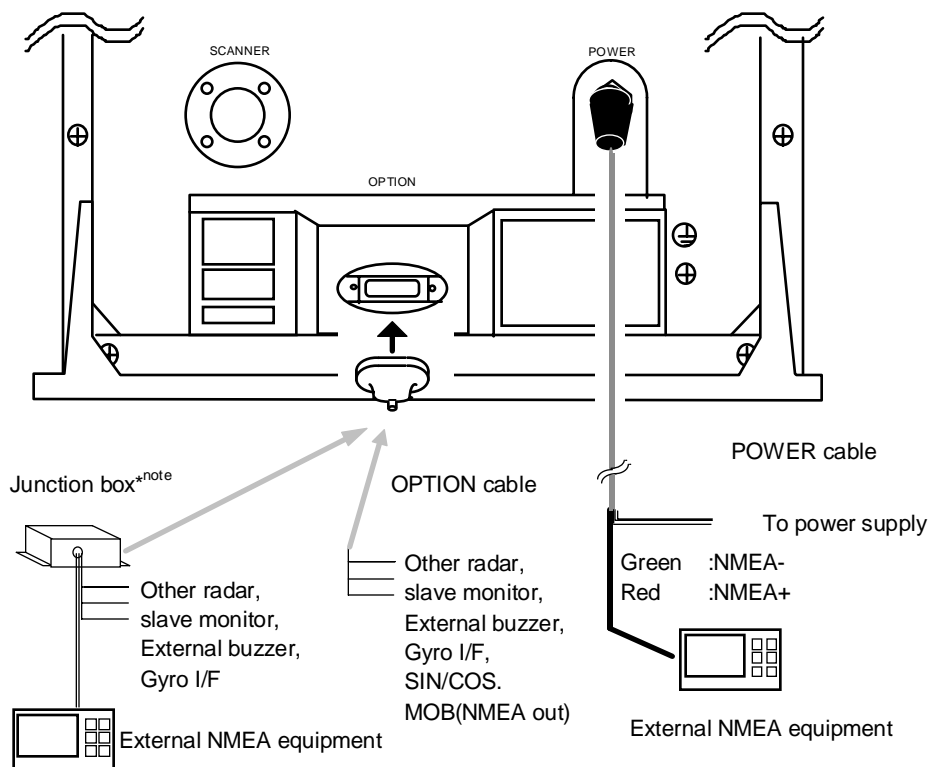

Fig.3-13 Connecting external equipment to display unit

3.10 Countermeasure for Electromagnetic Interference

RA40C/41C/42C radar provides shields in the units and the inter-unit connection cable. When the radar, however, is closely installed to radio equipment such as VHF transceiver, UHF transceiver, etc., or the radar and/or radio equipment are not sufficiently grounded to the hull or ship's earth, the radar may happen to cause EMI trouble.

Followings are general procedures for reducing EMI due to radars. When installing radars, refer to them, and also check the radio equipment EMI trouble with operating the radar and radio equipment.

(1) Installation Place of Radar

The display unit, scanner unit and inter-unit connection cable should be located apart from the main unit, feeder, antenna coupler and antenna of radio equipment as far as possible.

Especially, proper installation of the feeder, antenna coupler and antenna of radio equipment is very important to improve EMI trouble.

(2) Laying Power Supply Cables

Following connections A and B are recommended to reduce conduction noise generated from radar. Connection C should not be used.

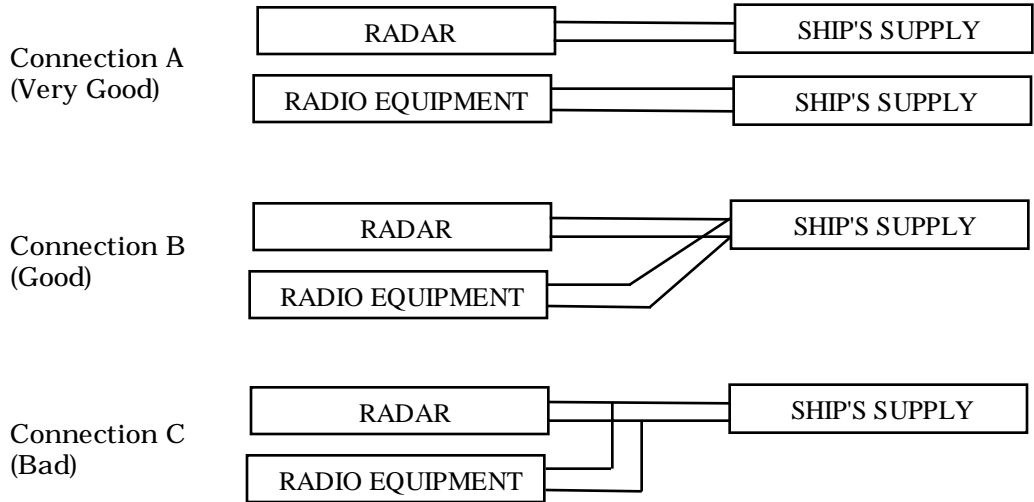

(3) Grounding

All equipment should be firmly grounded at the earth nearest hull with copper plates or braided wires.

Improvement Procedure for EMI

- (1) Confirm grounding on the radar and radio equipment. However, some equipment, on which grounding is not always necessarily, have a possibility of EMI improving when taking off their grounding. Try to take off grounding.
- (2) Confirm power supply cable connections and modify to the connection A or B above.
- (3) Try to shift the display unit and inter-unit connection cable of radar to be apart from radio equipment.
- (4) Try to shift the feeder of radio equipment to be apart from each units and the inter-unit connection cable of radar.
- (5) Try to shift the antenna coupler and antenna of radio equipment to be apart from the scanner unit and inter-unit connection cable of radar.

3.11 When Discarding Your Radar _____

When discarding your RA40C/41C/42C radar, consult the distributor to get information on precautions to be followed. Tab.3-7 below lists the primary component materials of the RA40C/41C/42C radar for your reference.

Tab.3-7 Component Materials

Scanner unit	Material	Display unit	Material
Radome	AES	Front panel	ABS
Chassis	A5052P	Rear panel	ADC12
Base	ADC12	Pedestal	ABS+PC
Antenna	A5052P		

CHAPTER 5. OPERATION

Basic operation of radar

The RA40C/41C/42C radar has several fixed-function keys on the front panel. These functions can be controlled by simply pressing the key. Also, special functions can be customized to soft-keys by user-setting. The followings explain the operation of each keys.

5.1 Powering On and Off

(1) Powering On

Press the "POWER" key. Buzzer sounds "pi" and starts the radar system. Screen brilliance is set to the level that of the radar system has been powered off.

(2) Powering off

Keep pressing the "POWER" key more than 3 seconds, then the radar system will power off.

5.2 Adjusting brilliance of screen and key-backlight

(1) Press the "BRILL" key. (Bar and figure indicating brilliance, and figure indicating key-backlight appear on the screen.)

(2) Adjust each items with the control knob. Items can be selected by up-down cursor.

(3) When the adjustment is finished, press either the "BRILL" key or the "ENT" key to exit from the adjustment screen. (Pressing some other key after adjustment will lead to the function of the pressed key.)

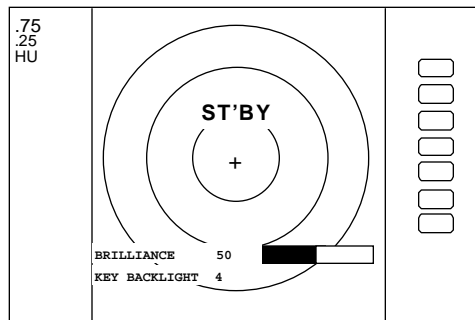
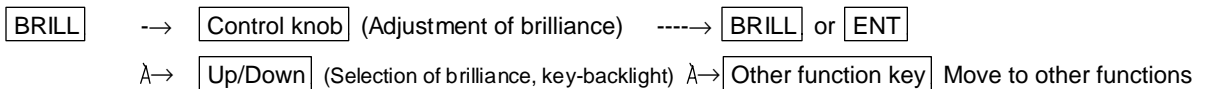

5.3.1 Powering On and Off

POWER ON

POWER

Press "POWER" key to power on.

2 minutes timer and "RADAR OFF" are displayed.

Keep pressing "POWER" key to power off.

SCREEN

BRILL

Press the "BRIL" key.

Control bar is indicated on the screen.

brilliance → Up/Down

Select brilliance.

→ Control knob

Adjust brilliance with

key backlight → Up/Down

Select key backlight.

→ Control knob

Adjust key backli

knob.

→ ENT

Press "ENT" key to return.

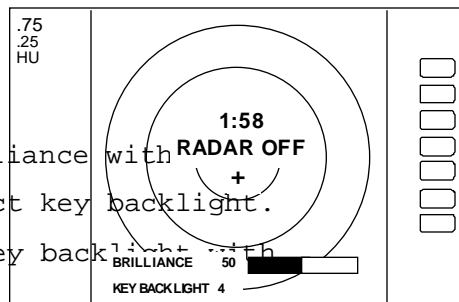

Radar turns into "STBY" mode when 2 minutes timer is finished and "STBY" is displayed.

5.3.2 Transmitting

START

POWER

Press "POWER" key to operate, radar picture appears on the screen. Another press "POWER" key, radar turns to stand-by mode.

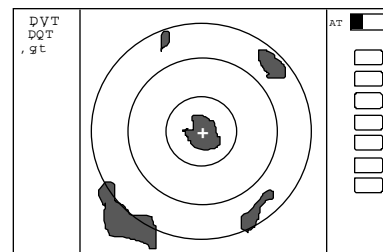

Keep pressing "POWER" key more than 3 seconds, radar turns to power off.

CHANGE RANGE

RANG UP or RANGE DOWN

Pressing "RANGE UP" key produces a long-distance range, "RANGE DOWN" key a short-distance range.

5.3.3 Adjusting brilliance of screen and key-backlight

xxx = keys to press

- (1) Press the "BRILL" key. (Bar and figure indicating brightness, and figure indicating back-light appears on the screen.)
- (2) Select brilliance or key-backlight with the up-down cursor.
- (3) Adjust each item with the control knob.
- (4) When the adjustment is finished, press either the "BRILL" key or the "ENT" key to exit from the adjustment screen. (Pressing some other key after adjustment will lead to the function of the pressed key.)

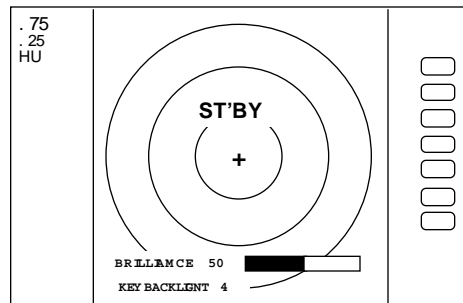
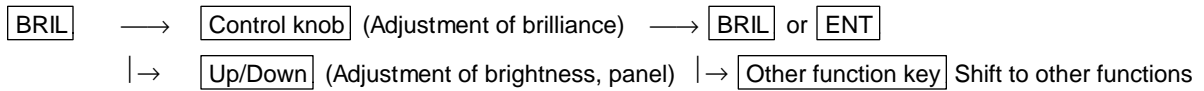

5.3.4 Changing Distance Range (RANGE UP, RANGE DOWN)

Pressing "RANGE UP" key produces a long-distance range, and "RANGE DOWN" key a short-distance range.

••RADOME SCANNER (RA40C)

RANGE	0.125	•0.25	0.5	0.75	1.5	3	6	12	24
Number of rings	2	2	2	3	6	6	6	6	6
Range ring interval	0.0625	0.125	0.25	0.25	0.25	0.5	1	2	4

RADOME SCANNER (RA41C)

RANGE	0.125	0.25	0.5	0.75	1.5	3	6	12	24	36
Number of rings	2	2	2	3	6	6	6	6	6	6
Range ring interval	0.0625	0.125	0.25	0.25	0.25	0.5	1	2	4	6

OPEN SCANNER (RA42C)

RANGE	0.125	0.25	0.5	0.75	1.5	3	6	12	24	48
Number of rings	2	2	2	3	6	6	6	6	6	6
Range ring interval	0.0625	0.125	0.25	0.25	0.25	0.5	1	2	4	8

5.3.5 Automatic adjustment (AUTO)

AUTO adjusts the GAIN, STC and FTC automatically.

If the "AUTO" key is pressed while GAIN, STC, or FTC are under manual settings, they will all be switched to AUTO or HBR(Harbor) mode.

Pressing "AUTO" key, AT1, AT2 and HBR changes in turn. Pressing STC key, all

controls return to manual state.

AT1 Use when find navigation way in much echo such as port area, narrow channel, small islands area. The control condition is similar to slightly down GAIN.

AT2 Use at open sea to suppress the sea clutter. The control condition is similar to high GAIN.

HBR Use at in a bay area, inlet, or a harbor. The control condition becomes manual STC by

using the value established HARBOR of ADJUST menu.

Note) Refer to "Setting STC circuit(STC)" in section 5.5.4.5.4(6).

Note) When you select HBR mode, FTC will be switched to MANU mode.

* What happens if GAIN, STC, and FTC keys are pressed during AUTO operation?

- 1) If GAIN key is pressed, Only GAIN enters a manual state.
- 2) If FTC key is pressed, Only FTC enters manual state.
- 3) If STC key is pressed, STC, GAIN, and FTC enter manual state.

5.3.6 Sensitivity adjustment (GAIN)

(1) When the "GAIN" key is pressed, the GAIN display on the left side of the screen will be reversed as

G 35 and the adjustable state will be entered.

(2) When the control knob is turned, the figure will be shifted within a range of 0 and 99, and the sensitivity can be manually adjusted. When the "AUTO" key is pressed, all (GAIN, STC and FTC) will enter an AUTO state.

(3) After the adjustment is finished, press the "GAIN" key to exit from the adjustment state. If some other function key is pressed, shift to that function will take place.

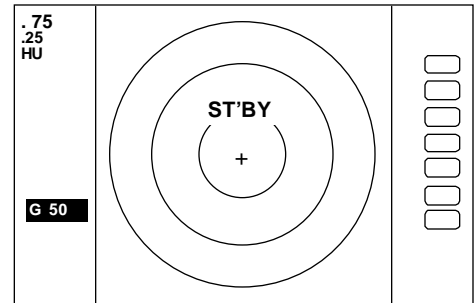

(a) To make adjustments by MANUAL (When the GAIN key is pressed under AUTO operation, shift to a manual operation will take place.)

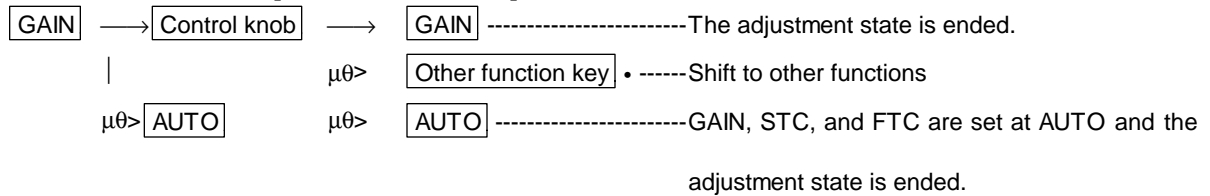

(b) To switch from the MANUAL state



5.3.7 Removing sea clutter (STC)

- (1) When the "STC" key is pressed, the STC display on the left side of the screen will be reversed as **S 35** and the adjustable state will be entered.
 - (2) When the control knob is turned, the figure will be shifted within a range of 0 and 99, and the STC can be manually adjusted. When the "AUTO" key is pressed, all (GAIN, STC and FTC) will enter an AUTO state.
 - (3) After the adjustment is finished, press the "STC" key to exit from the adjustment state. If some other function key is pressed, shift to that function will take place.
- (a) To make adjustments by MANUAL (When the STC key is pressed under AUTO operation, shift to a manual operation will take place.)

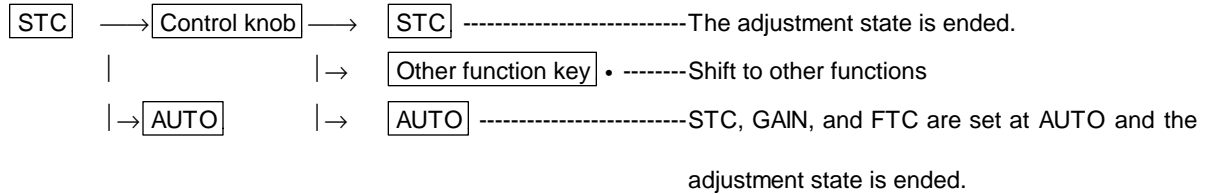

NOTE) When you select MANU mode, GAIN and FTC will be switched to MANU mode, too.

- (b) To switch from the MANUAL state



5.3.8 Removing rain and snow clutter (FTC)

- (1) When the "FTC" key is pressed, the FTC display on the left side of the screen will be reversed as **F 50** and the adjustable state will be entered.
- (2) When the control knob is turned, the figure will be shifted within a range of 0 and 99, and the sensitivity can be manually adjusted. When the "AUTO" key is pressed, all (GAIN, STC and FTC) will enter an AUTO state.
- (3) After the adjustment is finished, press the "FTC" key to exit from the adjustment state. If some other function key is pressed, shift to that function will take place.

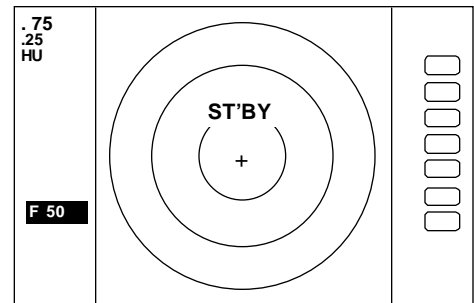

- (a) To make adjustments by MANUAL (When the FTC key is pressed under AUTO operation, shift to a manual operation will take place.)

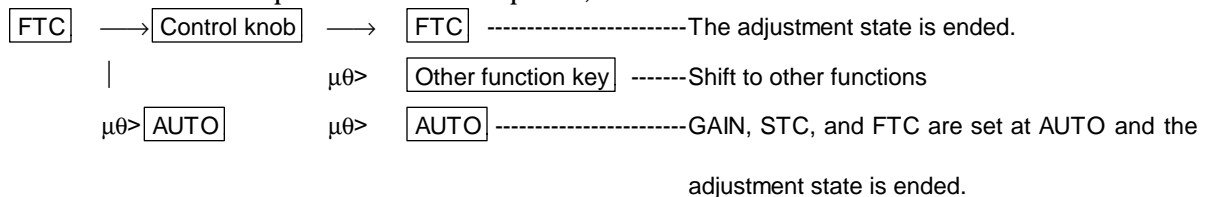

- (b) To switch from the MANUAL state

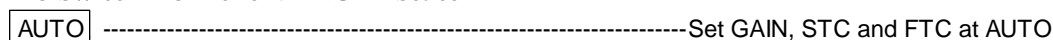

5.3.9 Man Over Board (MOB)

Pressing the MOB key will send the own ship's position data to the external equipment through NMEA port with "WPL" format. There is no change on the screen.

To check the MOB position data, select "MOB" from the "WINDOW" menu in the "SETUP". The position of MOB and current position will be displayed on the screen. If press the "MOB" key while watching the MOB screen, MOB data will be cleared and return to previous screen. If press other keys, MOB data will be remained and return to previous screen.

•Outline of soft keys

Any function can be optionally allocated to the key upon which numbers 1-7 are indicated. A maximum of 4 groups of functions can be allocated to each soft key, and switching between those functions is conducted by the "NEXT" key.

5.4.1 Bearing measurement (EBL1)

(a) Bearing measurement by EBL1

- (1) When "EBL1" key is pressed, electric bearing line (EBL1) appears and the angle from the direction of the ship's head which is set at 0 °will appear in a reverse display at the lower left of the screen(Note).
- (2) Use the control knob to place the direction cursor on the target, and read the angle.
- (3) After the setting
 - i) If "EBL1" key is pressed, the setting is completed.
 - ii) If "other function" key is pressed, the function will be shifted to that of the pressed key with the setting condition still in effect.

note: 1 xxx.x φ indicates EBL1.

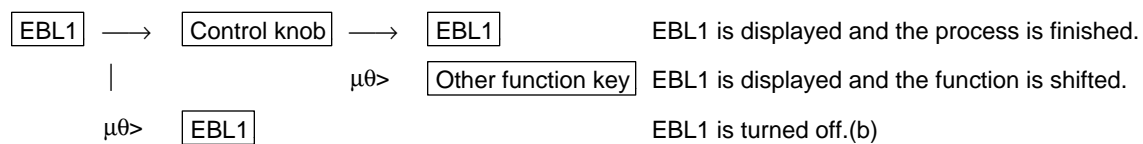

(b) To turn off the EBL1

When the "EBL1" key is pressed twice, EBL1 disappears. (EBL1 OFF)

Note: Refer to "5.5.1.1 Bearing measurement (EBL1)".

5.4.2 Bearing measurement (EBL2)

The operation is the same as EBL1. Refer to the EBL1 operation. The "EBL2" will appear in a reverse display at the lower right of the screen

5.4.3 Distance measurement (VRM1)

(a) Distance measurement by VRM1

- (1) When "VRM1" key is pressed, variable range marker (VRM1) appears and the distance in a reverse display appears at the lower left of the screen.
- (2) Place the marker on the front edge of the target with the control knob and read the distance.
- (3) After the setting
 - i) If "VRM1" key is pressed, the setting is completed.
 - ii) If "other function" key is pressed, the function will be shifted to that of the pressed key with the setting condition still in effect.

note: 1 xxx.x NM indicates VRM1.

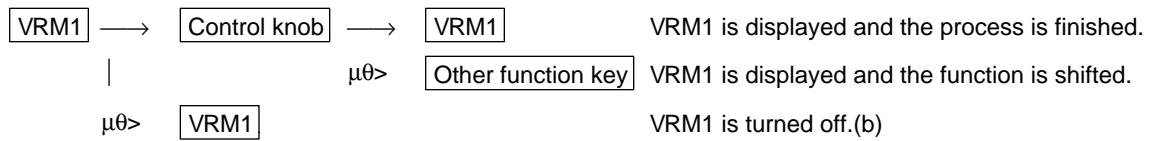

(b) To turn off the VRM1

When the "VRM1" key is pressed twice, VRM1 disappears. (VRM1 OFF)

Note: Refer to "5.5.1.2 Determining the distance (VRM1)".

5.4.4 Distance measurement (VRM2)

The operation is the same as VRM1, refer to VRM1 operation. The "VRM2" will appear in a reverse display at the lower right of the screen

5.4.5 Measuring the angle between two points (FL EBL2)

Note: VRM2 and EBL2 do not follow the OFF-C function while floating.

Note: Refer to "5.5.1.5 Measuring the distance or angle between two points (FL EBL2, FL VRM2)".

(a) Setting a reference point for measurement of the angle.

(1) Press "FL EBL2" key. "SET START POINT" is displayed and a small cross mark appears.

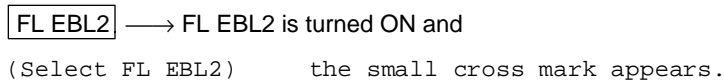

(2) Use the left-right and up-down cursor keys to place the small cross mark on one of the two echoes whose angle will be measured, and press the "ENT" key.



(b). Measuring

Perform the operations in the above mentioned and "measuring the angle(EBL2)", and place the EBL2 on another echo.

EBL2 is displayed on the screen based on the placed fixed cross cursor.

"2 xxx.x°" which is displayed at the lower right will be the angle between the two points.

5.4.6 Measuring the distance between two points (FL VRM2)

Note: Refer to "5.5.1.5 Measuring the distance or angle between two points (FL EBL2, FL VRM2)".

(a) Setting a reference point for measurement of the angle.

(1) Press "FL VRM2" key. "SET START POINT" is displayed and a small cross mark appears.

→ FL VRM2 is turned ON and

(Select FL VRM2) the small cross mark appears.

(2) Use the left-right and up-down cursor keys to place the small cross mark on one of the two echoes whose angle will be measured, and press the "ENT" key.

& → -----

Criterion of the reference point is set.

(Place the cross cursor on an echo)

(b) Measuring

Perform the operations in the above mentioned and "measuring the distance(VRM2)", and place the VRM2 on another echo.

VRM2 is displayed on the screen based on the placed fixed cross cursor.

" xx. xNM" which is displayed at the lower right will be the distance between the two points.

5.4.7 Changing the group of Soft Keys (NEXT)

Any function can be optionally allocated to the key upon which numbers 1-7 are indicated. A maximum of 4 groups of functions can be allocated to each soft key, and switching between those functions is conducted by the "NEXT" key.

The "NEXT" key switches between allocated function groups on the soft key which numbers 1-7 are indicated.

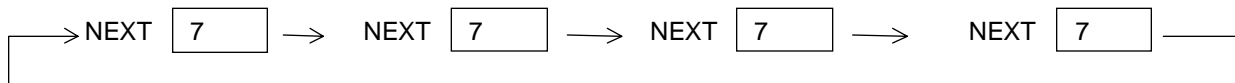

Επιερψ τιμε πρεσσιγγ τηε ∇NEET∇ κερ, function groups changes to another groups included pressing "NEXT" key. The function groups can also be changed at the "KEY ASSIGNMENT" function in the "CUSTOM" menu of the "SETUP" with left-right cursor key.

Operation

Soft Key Setting Example

SET1		SET2		SET3		SET4	
EBL1	<input type="text" value="1"/>	EBL2	<input type="text" value="1"/>	RINGS	<input type="text" value="1"/>	PPI	<input type="text" value="1"/>
VRM1	<input type="text" value="2"/>	VRM2	<input type="text" value="2"/>	TUNE	<input type="text" value="2"/>	PPI / 3D	<input type="text" value="2"/>
VAR RNG	<input type="text" value="3"/>	→ FL EBL2	<input type="text" value="3"/>	→ ST	<input type="text" value="3"/>	→ PPI / PP	<input type="text" value="3"/>
TRACK	<input type="text" value="4"/>	FL	<input type="text" value="4"/>	ZOOM	<input type="text" value="4"/>	PPI / NAV	<input type="text" value="4"/>
TARGE	<input type="text" value="5"/>	GZ	<input type="text" value="5"/>	SLEEP	<input type="text" value="5"/>	ALL	<input type="text" value="5"/>
SEL WIN	<input type="text" value="6"/>	OFF-C	<input type="text" value="6"/>	PICTURE	<input type="text" value="6"/>	ALL	<input type="text" value="6"/>
NEXT	<input type="text" value="7"/>	NEXT	<input type="text" value="7"/>	NEXT	<input type="text" value="7"/>	NEXT	<input type="text" value="7"/>

The function can be changed at the "KEY ASSIGNMENT" function in the "CUSTOM" menu of the "SETUP".

5.4.8 Erasing heading maker temporarily (HDG OFF)

Press the "HDG OFF" key. The heading marker is not displayed as long as you hold it down.

5.4.9 Using parallel cursors (///CSR)

Press the "///CSR" key. Parallel cursors will appear on the screen. As you move EBL, the parallel cursors also move.

To cancel the "///CSR" function, press "///CSR" key once more.

Note: Refer to "5.5.1.8 Using parallel cursors (///CSR)".

5.4.10 Establishment of the indication of the RANGE RINGS (RINGS)

Press the "RINGS" key. Range Rings will appear on the screen. To cancel the "RINGS" function, press "RINGS" key once more.

Note: Refer to "5.5.1.9 Establishment of the indication of the RANGE RINGS (RINGS)".

5.4.11 ON/OFF of variable range function (VAR RNG)

Usually the range changes in steps as 0.5--0.75--1.5--3.0--....., but using this function will enable a consecutive change such as 0.5--0.6--0.7--0.8--..... .

Press the "VAR RNG" key. The VAR RNG function becomes valid and **VAR** will be displayed at the upper left of the screen (beside MODE). To cancel the "VAR RNG" function, press "VAR RNG" key once more.

The range changes continuously with the up-down cursor while the VAR RNG function is on, and it changes in steps with the "RANGE UP" or "RANGE DOWN" keys.

If pressing other keys, return to the normal state from continuously range change state.

5.4.12 Changing display modes (MODE)

- (1) Select MODE from the pull-down display items using the up-down cursor keys, and press the "ENT" key.
- (2) When the HU/HS/NU/CU/TM sign is displayed beside the MODE item, select display mode with the up-down cursor keys and press the "ENT" key.
- (3) The setting will be completed when the "ENT" key is pressed after the selection. (NOTE1,2)

Press the "MODE" key, the display mode will change on every pressing to HU, HS, NU, CU, TM in order. The mode select at the upper of the screen is indicated. However, a setting will be needed for the ship's speed if TM is selected. Also, a heading or a course information is necessary for NU, CU and TM.

note: TM is παλιό ονλνσ ον ΠΠΠ σχρεεν. Τησ μοδε ωιλλ χηανγε το NY ον τησ οτηερ σχρεεν αυτοματιχαλλσ.

Note: Refer to "5.5.2.1 Changing display mode (MODE)".

5.4.13 Guard Zone (GZ)

OFF-C → **Up/Down & Left/Right** → **ENT** ----- Conduct Off Center to exit the adjustment state.

Note: VRM2 and EBL2 do not follow the OFF-C function while floating.
The function operates on PPI screen only.

(b) To cancel the setting

OFF-C -----The "OFF-C" display at the upper right disappears and function returns to the ordinary state from the Off Center state.

5.4.15 Setting of the SLEEP function(SLEEP)

This function sends a 30-second-transmissions during pre-fixed hours. After a transmission, a power-saving mode is entered with the screen in ST'BY state (the scanner-OFF state) and the LCD backlight turned off. This action is repeatedly executed.

Usage example, set a guard zone and have the warning signal automatically confirmed every prefixed period.

Press the "SLEEP" key. Every pressing the key, "SLEEP" function will be set as 5-minutes, 10-minutes, 15-minutes, or off.

When a transmission is conducted after setting a SLEEP mode, a ST'BY state is entered and the backlight turns off after a 30-second-transmission. (Power-saving mode). Two minutes before the fixed time the backlight turns on and the 2-minute timer starts. Then, at the fixed time another 30-second-transmission begins. This series of actions are repeated. If any one key is pressed during the course of this action, the SLEEP function will be canceled.

Note: Refer to "5.5.2.4 Setting of the SLEEP function(SLEEP)".

(1) Setting procedure

SLEEP	→ (Select 5min.) →	ENT	→	POWER	-----→ 30-second-transmission every 5 min. μ transmission ON
SLEEP	→ (Select 10min.) →	ENT	→	POWER	-----→30-second-transmission every 10 min. μ transmission ON
SLEEP	→(Select 15min.) →	ENT	→	POWER	-----→30-second-transmission every 15 min. μ transmission ON
SLEEP	→(Select OFF) -----				SLEEP function is turned OFF

Setting completed

5.4.16 Tuning adjustment (TUNE)

- (1) When the "TUNE" key is pressed, the TUNE display on the upper-right side of the screen will be reversed as **35** and the adjustable state will be entered.
- (2) When the control knob is turned, the figure will be shifted within a range of 0 and

99, and the receiver tuning can be manually adjusted.

- (3) After the adjustment is finished, press the "ENT" key to exit from the adjustment state. If some other function key is pressed, shift to that function will take place.

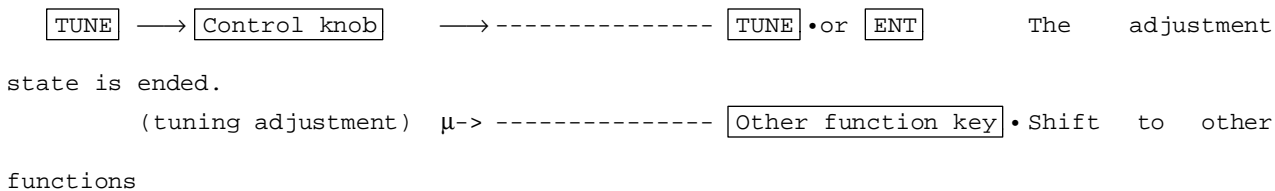

Note: Use the "MENU" to return auto-tuning state.

Note: Refer to "5.5.3.4 Adjusting receiver tuning (TUNE)".

5.4.17 Echo expansion (ST)

Expanding the echo to the direction of the distance.

When the "ST" key is pressed, "ST1" is displayed on the left side of the screen and the state of echo expansion is entered. This changes the picture to display echoes expanding in the direction of the distance. Two types of echo expansion exist, which are alternated as follows , every time this key is pressed.

Note: Refer to "5.5.3.5 Echo expansion (ST)".

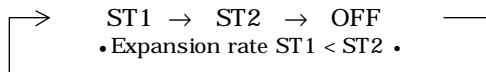

Note: The "OFF" state is not displayed on the screen and the "ST2" display disappears.

5.4.18 Displaying locus of target (TRACK)

When the "TRACK" key is pressed, "TK 15SEC" is displayed on the left side of the screen and track mode is entered. 15S indicates the length of the track, and displays a maximum of 15-second-long sailing track.

Note: Refer to "5.5.3.6 Displaying locus of target (TRACK)".

Every time this key is pressed, the course length switches as follows.

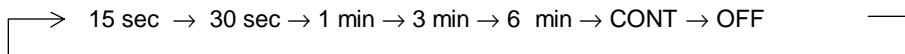

Note: The "OFF" state will not displayed on the screen and the "TK xx " display will disappear.

5.4.19 Enlarging selected areas (ZOOM)

The video image centering around the cross cursor is doubled as it is displayed on the screen.

Press the "ZOOM" key to "ZOOM" ON. A small cross cursor for setting and "SET ZOOM POINT" are displayed at the screen center and at the bottom respectively, and the magnification point is to be set. Use cursor keys to move the cross cursor to the point to be magnified, press

the "ENT" key and the setting is completed. The area around the cross cursor is displayed in 2x magnification, with blinking "ZOOM" displayed at the screen upper right, indicating that a ZOOM display is being conducted.

To cancel the ZOOM function, press the "ZOOM" key again or change the range scale.

Note: Refer to "5.5.3.7 Enlarging selected areas (ZOOM)".

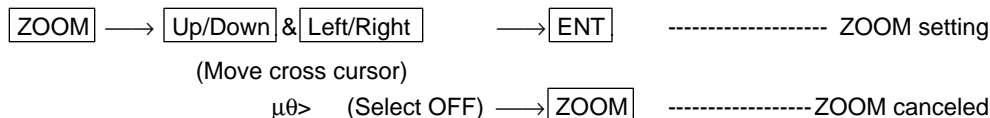

Note1: VRM2 and EBL2 do not follow the ZOOM function during a floating state.

Note2: Normal screen returns when you change the range scale.

Note3: ZOOM function is unusable in 3D/PPI screen.

Note4: ZOOM function is unusable in OFF-C.

Note5: Center of ZOOM can be set any desired position within the set range.

5.4.20 Increasing sensitivity (S/L)

The pulse width is automatically changed as you change the range. However, if you want to increase sensitivity, you can choose sensitivity from two pulse lengths. The short pulse (SHORT) gives you sharp images with high distance resolution. The long pulse (LONG) provides high sensitivity and shows targets in large size for easy identification although distance resolution is reduced.

Press the "S/L" key to select the Pulse length(LONG or SHORT). The pulse length changes L(Long) and S(Short) alternately.

Note: Refer to "5.5.3.8 Increasing sensitivity (S/L)".



5.4.21 Switching the screen (SEL WIN)

Switching to the desired screen for activation on a 2-screen display(PPI+PPI).

When change the range, or adjust the GAIN, STC, or FTC, or control the VRM, EBL, select the desired screen first.

ex.) To be used for switching the range on the PPI+PPI screen.

When the "SEL WIN" key is pressed, the range of the selected screen will be displayed in reverse, indicating that the screen is active.

Note: Refer to "5.5.4.2 Switching screens on PPI/PPI screen (SEL WIN)".

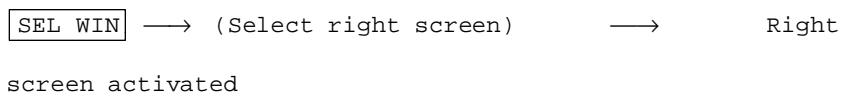

μθ> or (Select left screen) → Left
 screen activated

If VRM1 is controlled on the screen that is oposit from current VRM1 displayed screen, VRM1 is moved and displayed to activated screen. The EBL1, EBL2, and VRM2 is the same manner.

5.4.22 Changing the color of screen (PICTURE)

The LCD display is affected by weather and day / night environment conditions. In some cases, you may find the LCD display is easier to view when the entire color of screen is changed.

Press the "PICTURE " key, a day display will appear if night display has been selected, and a night display if day display selected.

Note: Refer to "5.5.4.3 Changing the color of screen (PICTURE)".

5.4.23 Change to PPI screen (PPI)

Press the "PPI" key, the screen will change to PPI screen.

Use to change the screen from other modes to PPI.

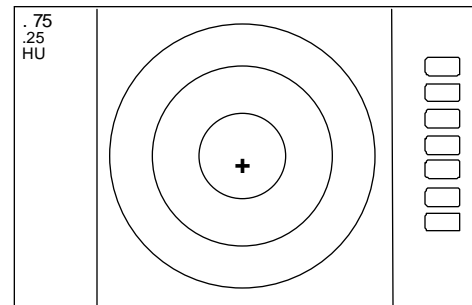

PPI screen

5.4.24 Change to SEMI3D/PPI screen (SEMI3D)

Press the "SEMI3D" key, the screen will change to SEMI3D/PPI screen.

Use to change the screen from other modes to SEMI3D/PPI.

Note: All controls, such as EBLs, VRMs effects both screen.

The ZOOM, OFF-C, FL EBL2, and FL VRM2 could not be used on this mode. The "SEMI3D" screen displays the center as ship's heading always.

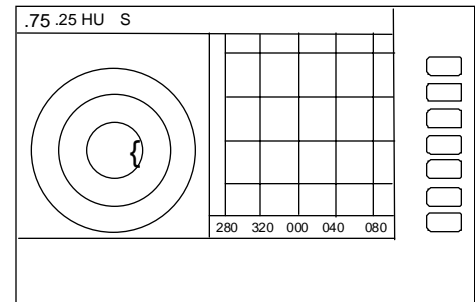

SEMI3D/PPI screen

5.4.25 Change to PPI/PPI screen (PPI/PPI)

Press the "PPI/PPI" key, the screen will change to PPI/PPI screen. Use to change the screen from other modes to PPI/PPI.

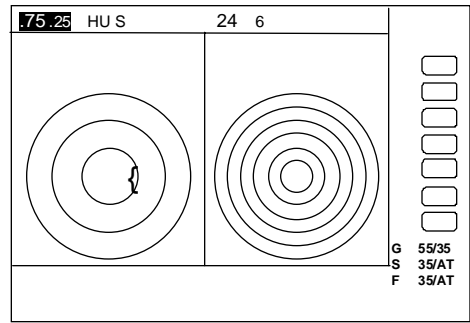

PPI/PPI screen

Note:

(1) The radar picture is refreshed with two scanning interval for each screen. Right screen picture is holded during refreshing left screen, left screen holded during refreshing right screen.

LEFT screen /-----/*****/-----/*****/-----/***** time→
 RIGHT screen *****/-----/*****/-----/*****/-----/

- (2) The ZOOM, OFF-C, FL EBL2, and FL VRM2 could not be used on this mode.
- (3) The range, GAIN, STC, FTC, GZ can be used independently for selected window with "SEL WIN".
- Selected window is that the range displayed in reverse character. Please refer to "SEL WIN".
- (4) The cross cursor can be controlled on selected window.

5.4.26 Change to PPI/NAV screen (PPI/NAV)

Press the "PPI/NAV" key, the screen will change to PPI/NAV screen.

Use to change the screen from other modes to PPI/NAV.

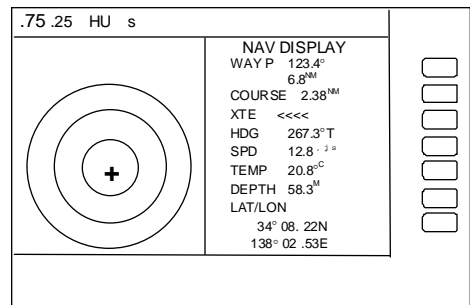

PPI/NAV screen

Note:

The ZOOM, OFF-C, FL EBL2, and FL VRM2 can not be used on this mode.

5.4.27 Change to ALL PPI screen (ALL PPI)

Press the "ALL PPI" key, the screen will change to ALL PPI screen.

Use to change the screen from other modes to ALL PPI.

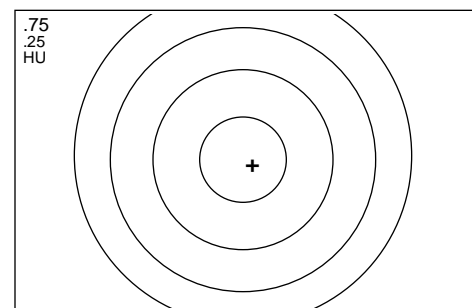

ALL PPI screen

Note:

- (1) The range, rings interval, display mode are displayed on the upper left of the screen. refreshing radar picture
- (2) Return to PPI screen mode pressing a key except MENU, range UP or DOWN, or POWER key

5.4.28 Change to ALL PPI/PPI screen (ALL PPI2) holding previous picture

Press the "ALL PPI2" key, the screen will change to ALL PPI/PPI screen.

Use to change the screen from other modes to ALL PPI/PPI.

Note:

- (1) The range, rings interval, display mode are displayed on the upper left of each screen.
- (2) Return to PPI/PPI screen mode pressing a key except MENU, range UP or DOWN, or POWER key.

(3) The radar picture is refreshed with two scanning interval for each screen. Right screen picture is holded during refreshing left screen, left screen holded during refreshing right screen. When your ship navigates in high speed, use PPI screen to get fast refreshing picture.

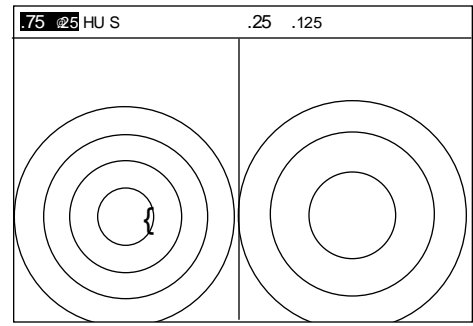

ALL PPI/PPI screen

5.5.2 Nav (Navigation) Menu

xxx = keys to press

Radar functions for navigation aid are in this menu.

•Common operations for the NAV menu

(Up to the point when "NAV" menu is selected from the main menu)

Press the "MENU" key and select "NAV" from the displayed 4 main menus using the left-right cursor. (The contents of the selected MENU will appear on a pull-down display in accordance with the movement of the left-right cursor.)

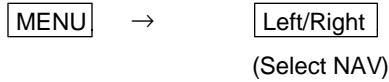

Further explanation about the NAV menu will be conducted on the assumption that this "common operation for the NAV menu" has already been completed.

5.5.2.1 Changing display mode (MODE)

- (1) Select MODE from the pull-down display items using the up-down cursor key, and press either the "ENT" key.
- (2) When the MODE sign is displayed beside the MODE item, select a mode with the up-down cursor keys and press the "ENT" key.
- (3) The display mode indicates upper-left on the screen.

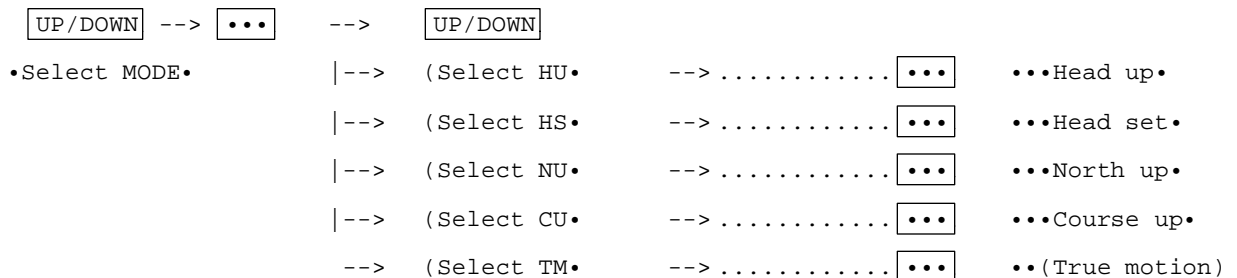
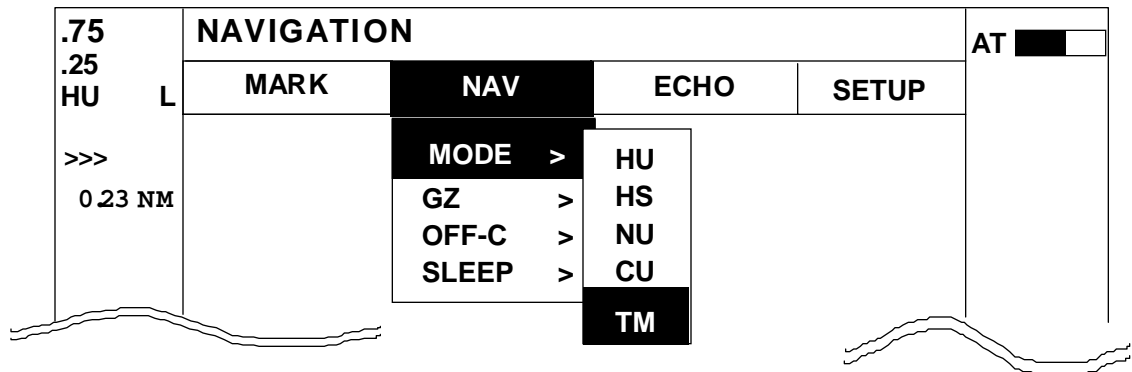

Note1: Navigation equipment (gyrocompass, magnet compass, or GPS) must be connected to your radar in NU, CU and TM modes.

Note2: In TM modes it is necessary to set as follow (1) or (2).

(1) Input of speed information from NMEA. (2) Set your ship's speed manually.

Note3: TM works only on PPI screen, NU is used automatically for the other screens.

5.5.2.2 Guard Zone (GZ)

A function that sets a guard zone of any distance and any angle range, creating alarm tone when either echoes above a certain level exist (IN MODE) or no echoes exist(OUT MODE).

Setting guard zone

- (1) Select GZ from the pull-down display items using the up-down cursor keys, and press the "ENT" key. ON/OFF sign is displayed beside the GZ item.

--> ----- ON/OFF sign is displayed.

- (2) Select "ON" by "common operation for the GZ menu", and press the "ENT" key.
- (3) The present mode setting will be displayed on the left side of the screen as GZ IN. A small cross cursor for setting the guard zone will be displayed at the screen center while "SET CENTER POINT" is displayed at the bottom, activating a guard zone setting state.

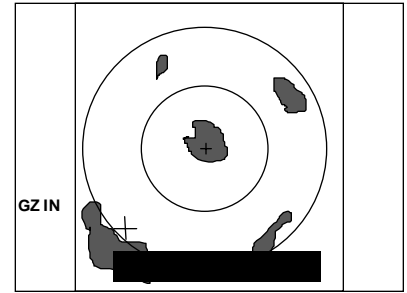

- (4) Use the up-down and left-right cursor keys to move the cross cursor to the center of the warning zone to be set, and press the "ENT" key.
- (5) From the cross cursor position set in (4) above as the center, expand the guard zone as follows.

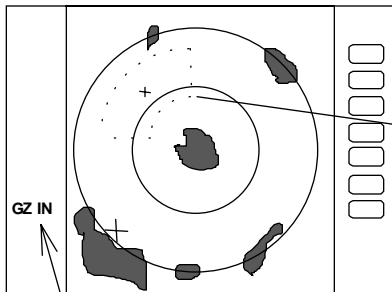

The mode (IN or OUT) is displayed when the state is ON. Nothing is displayed when it is OFF.

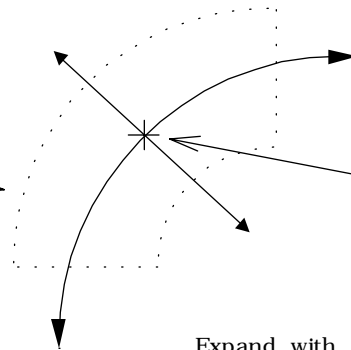

Expand with the right cursor key in the direction of the angle. Use the left cursor key to make the zone

The central position of the guard zone. With this point as the center, the zone can be expanded in the directions of the distance and the angle with the upper and right cursor keys

Expand with the up cursor key in the direction of the distance. Use the down cursor key to make the zone smaller.

- (6) After the setting the guard zone, finish by pressing the "ENT" key.

To cancel the guard zone function, select "OFF" by "common operation for the GZ menu", and press the "ENT" key.

--> & --> --> & •••> ----- Setting completed

(Setting the center of GZ)

(Setting the scope of GZ)

Stop the alarm tone

When the alarm sounds, press any key to stop. But the guard zone function is still working, the alarm may sounds again. To "OFF" the guard zone function, select "OFF" from GZ menu.

Note1: To switch the IN or OUT mode, refer to "Guard Zone Mode" in section 5.5.4.5.3 "Changing the content of settings 2 (PRESET2)"

Note2: To set the guard zone level, refer to "Guard Zone LevelL" in section 5.5.4.5.3 "Changing the content of settings 2 (PRESET2)"

5.5.2.3 Shifting display in specific direction (OFF-C)

Displaying the location specified by the cross cursor as the vessel's location.

- (1) Select OFF-C from the pull-down display items using up-down cursor key, and press the "ENT" key.
- (2) When the ON/OFF sign is displayed beside the OFF-C item, select ON with the up-down cursor keys and press the "ENT" key.
- (3) **OFF-C** is displayed at the upper right and "SET OFF CENTER POINT" at the bottom of the screen, and setting is ready to be entered. Move the cross cursor with the cursor keys to move the ship's to the intended location, and press the "ENT" key. The ship's location will be displayed at the cursor's location. The display at the upper right will be normalized from the reverse state, which indicates that the "OFF-C" state is entered.
- (4) To cancel "OFF-C" function, either select OFF in (2)

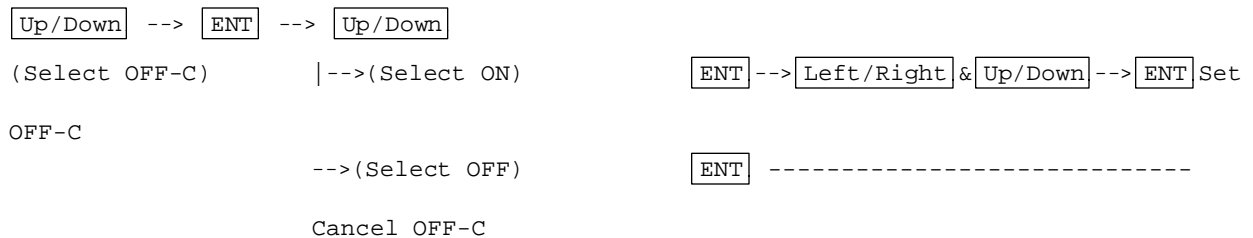

Note: VRM2 and EBL2 do not follow the OFF-C function while floating.

The function operates only on PPI screen.

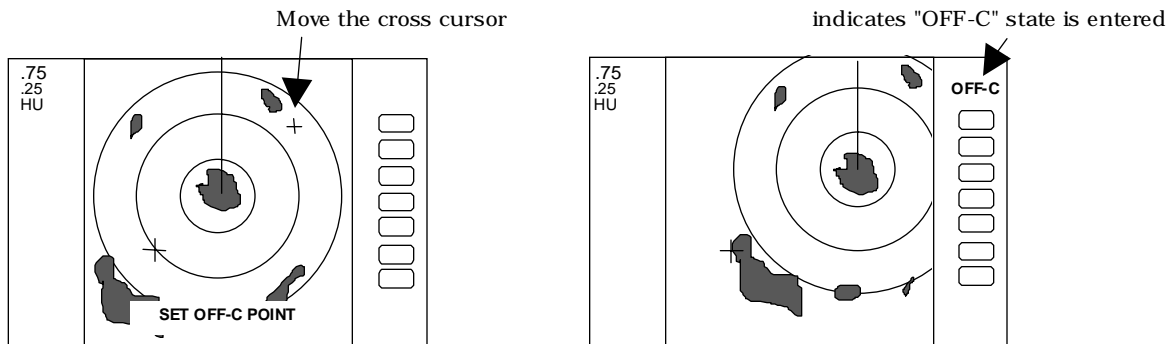

5.5.2.4 Setting of the SLEEP function(SLEEP)

This function sends a 30-second-transmissions during pre-fixed hours. After a transmission, a power-saving mode is entered with the screen in STBY state (the scanner-OFF

state) and the LCD backlight turned off. This action is repeatedly executed.

Usage example, set a guard zone and have the warning signal automatically confirmed every prefixed period.

- (1) Use the up-down cursor keys to select SLEEP from among the pull-down display items, and press the "ENT" key.
- (2) When the OFF/5min/10min/15min display has appeared beside the SLEEP item, select a time to be set with the up-down cursor keys.
- (3) Press the "ENT" key and the setting is completed. When the SLEEP function is to be canceled, select OFF in (2).

When a transmission is conducted after setting a SLEEP mode, a ST'BY state is entered and the backlight turns off after a 30-second-transmission. (Power-saving mode). Two minutes before the fixed time the backlight turns on and the 2-minute timer starts. Then, at the fixed time another 30-second-transmission begins. This series of actions are repeated. If any one key is pressed during the course of this action, the SLEEP function will be canceled.

(a) Setting procedure

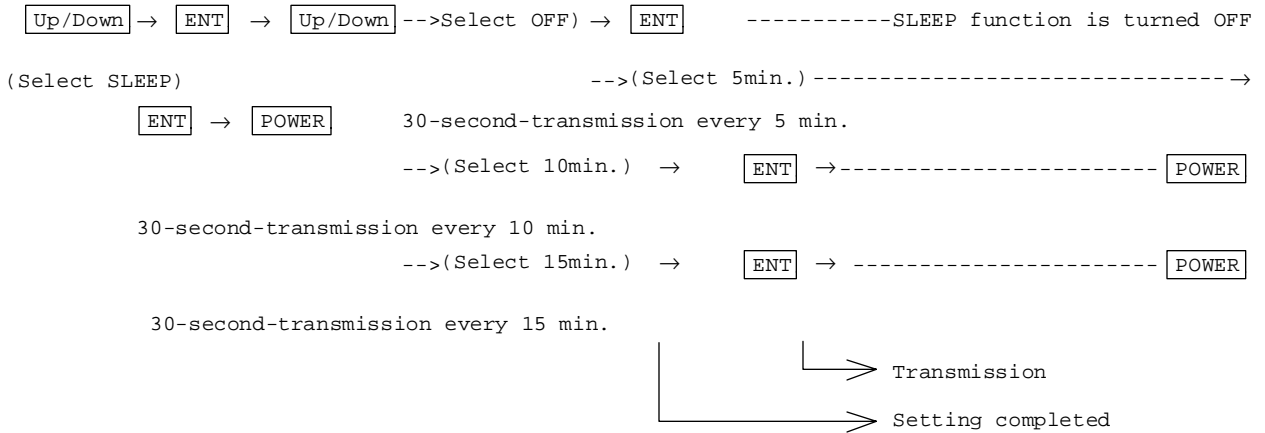

(b) Action after setting

SLEEP setting•5min. •				•Operation•	
•(Under Tx•	(Under power-saving mode•	• 2min. timer in use•	•(Under Tx•	••(Under power-saving mode•	
0 sec.	30 sec.	3 min.	5min.	5and a half min.	•Time used•
TX Start	TX OFF	Backlight ON	Tx Start	TxOFF	•Action•
		Countdown start			

-- What happens if a key is pressed after a SLEEP mode setting?

If a transmission is conducted and a key is pressed after setting a SLEEP mode, power-saving mode is entered 30 seconds after key is pressed.

-- What happens if a key is pressed during the SLEEP mode?

- a) If a key is pressed during the power-saving mode, the SLEEP function is canceled and the 2-minute timer starts.

b) If a key is pressed while the 2-minute timer is in use, or during transmission , the SLEEP function is canceled.

5.5.3 Echo Menu

xxx...keys to press

Adjustment options to be conducted on the echoes displayed on the screen

•**Common operations for the ECHO menu** (Up to the point when "ECHO" menu is selected from the main menu)

Press the "MENU" key and select "ECHO" from the displayed 4 main menus using the left-right cursor. (The contents of the selected MENU will appear on a pull-down display in accordance with the movement of the left-right cursor.)

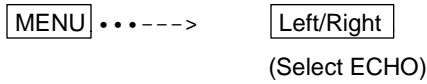

When the above-mentioned operations have been conducted, the items of the ECHO menu are vertically displayed.

Further explanation about the ECHO menu will be conducted on the assumption that this "common operation for the ECHO menu" has already been completed.

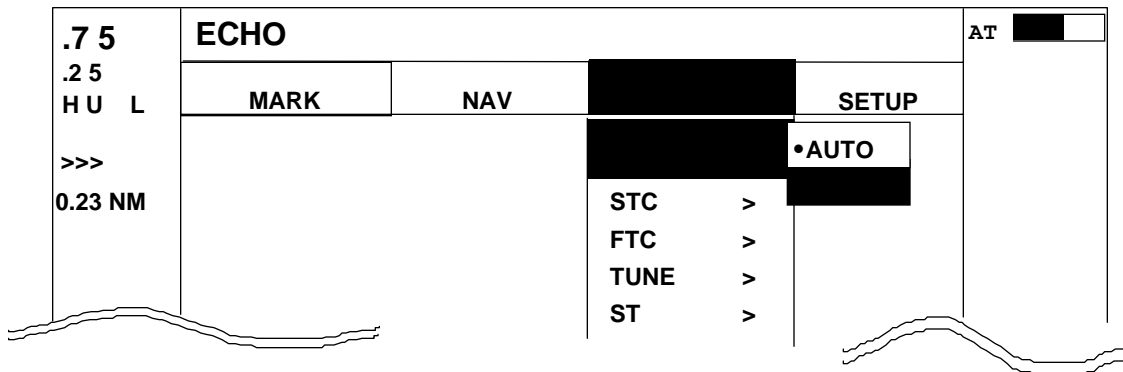

5.5.3.1 Sensibility adjustment (GAIN)

- (1) Use the up-down cursor keys to select GAIN from among the pull-down display items, and press either the "ENT" key or the right cursor key.
- (2) Select MANU from the MANU/AUTO display beside the GAIN item using the up-down cursor keys, and press the "ENT" key.
- (3) The present state of GAIN is displayed in reverse on the screen left as **•G 35•** and an adjustable state is entered. When the control knob are operated in this state, the figure alternates within a range of 0 and 99 and the GAIN can thus be adjusted.
- (4) The adjustment is completed by pressing the "ENT" key after adjustment.

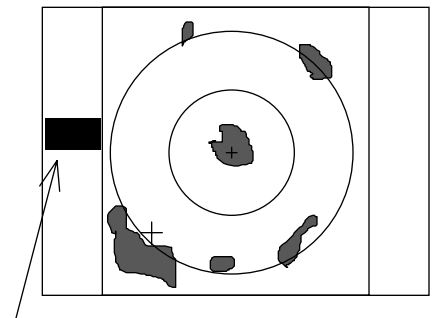

When AUTO action is to be entered, select AUTO in (2) and press the "ENT" key to complete the setting.

The setting value is displayed during MANUAL operation.
AT is displayed during AUTO operation.
(The same applies to STC, FTC and TUNE.)

```

Up/Down --> ENT --> Up/Down
(Select GAIN)      |->(Select MANU) -----> Control knob --> ENT
                   |
                   | Set to MANU mode
                   | (GAIN adjustment)
                   |->(Select AUTO) -----> ENT
                   |
                   | Set to AUTO mode

```

5.5.3.2 Removing sea clutter (STC)

Refer to the section, “Sensibility adjustment (GAIN)”.

```

Up/Down --> ENT --> Up/Down
(Select STC)      |->(Select MANU) --> ENT --> Control knob --> ENT Set to
MANU mode
                   |
                   | (STC adjustment)
                   |->(Select AUTO) --> ENT -----
                   |
                   | Set to AUTO mode

```

Note: When you select MANU mode, GAIN and FTC will be switched to MANU mode, too.

Note: When you select HARBOR mode, FTC will be switched to MANU mode.

5.5.3.3 Removing rain and snow clutter (FTC)

Refer to the section, “Sensibility adjustment (GAIN)”.

```

Up/Down --> ENT --> Up/Down
(Select FTC)      |->(Select MANU) --> ENT --> Control knob --> ENT Set to
MANU mode
                   |
                   | (FTC adjustment)
                   |->(Select AUTO) --> ENT -----
                   |
                   | Set to AUTO mode

```

5.5.3.4 Adjusting receiver tuning (TUNE)

Refer to the section, “Sensibility adjustment (GAIN)”.

```

Up/Down --> ENT --> Up/Down
(Select TUNE)     |->(Select MANU) --> ENT --> Control knob --> ENT Set to MANU
mode
                   |
                   | (TUNE adjustment)
                   |->(Select AUTO) --> ENT -----
                   |
                   | Set to AUTO mode

```

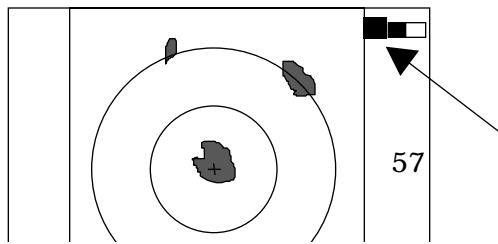

5.5.3.5 Echo expansion (ST)

Expanding the echo to the direction of the distance.

Two types of echo expansion exist, select ST1 or ST2 from the menu.

- (1) Use the up-down cursor keys to select ST from among the pull-down display items, and press the "ENT" key.
- (2) Select ST1 or ST2 from the display beside the ST item using the up-down cursor keys, and press the "ENT" key.

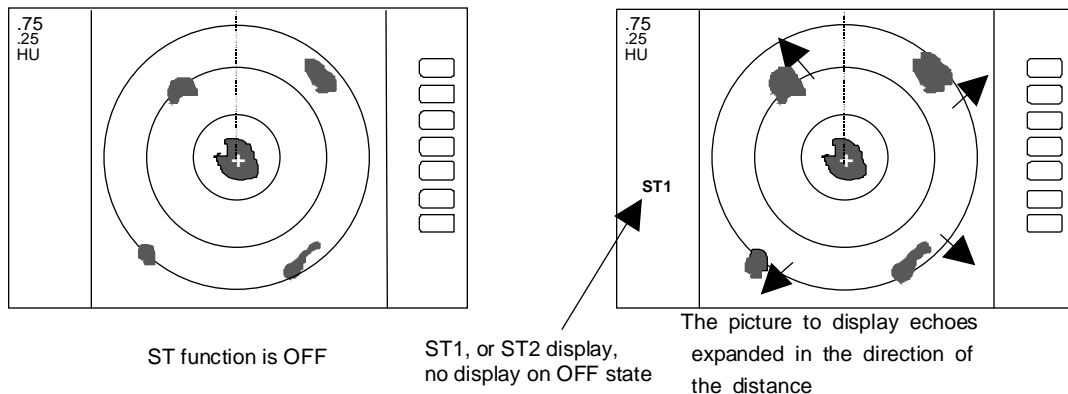
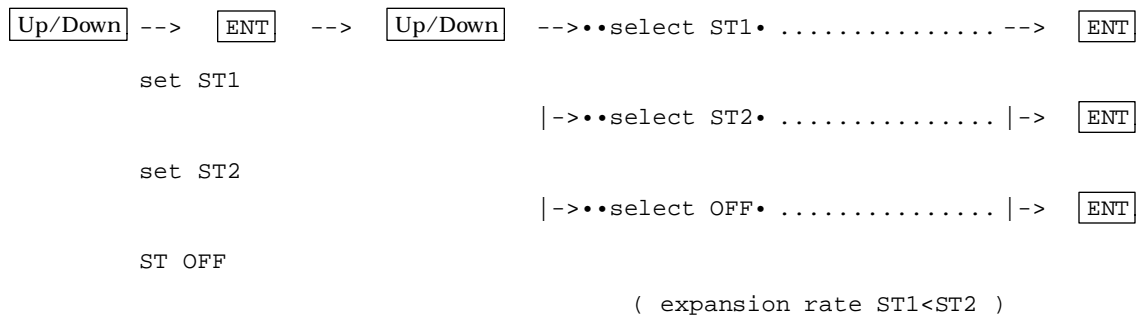

5.5.3.6 Displaying locus of target (TRACK)

- (1) Use the up-down cursor keys to select TRACK from among the pull-down display items, and press the "ENT" key.
- (2) Select 15SEC, 30SEC, 1MIN, 3MIN, 6MIN, or CONT from the display beside the TRACK item using the up-down cursor keys, and press the "ENT" key.

"TRK 15S" is displayed on the left side of the screen and track mode is entered. 15S indicates the length of the track, and displays a maximum of 15-second-long sailing track.

Note: When PPI+PPI or ALL PPI+PPI screen mode is used, TRACK function can be used only on CONT mode.

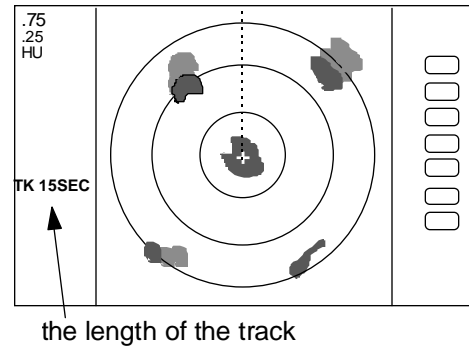
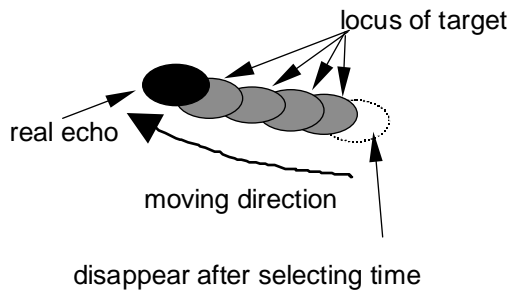

```

up/down  -->  ENT      -->  up/down ..... ->••select OFF•
-> ENT     TRACK OFF
|----->••select 15SEC• .....-> ENT
set 15sec. track
|----->••select 30SEC• .....-> ENT
set 30sec. track
|----->••select 1MIN• .....-> ENT
set 1 min. track
|----->••select 3MIN• .....-> ENT
set 3 min. track
|----->••select 6MIN• .....-> ENT
set 6 min. track
|----->••select CONT• .....-> ENT
set continue track

```

5.5.3.7 Enlarging selected areas (ZOOM)

The video image centering around the cross cursor is doubled as it is displayed on the screen.

- (1) Use the up-down cursor keys to select ZOOM from among the pull-down display items, and press the "ENT" key.
- (2) Select the ON using up-down cursor keys from the ON/OFF display beside the ZOOM item, and press the "ENT" key.
- (3) A small cross cursor for setting and "SET ZOOM POINT" are displayed at the screen center and at the bottom respectively, and the magnification point is to be set. Use cursor keys to move the cross cursor to the point to be magnified, press the "ENT" key and the setting is completed. The area around the cross cursor is displayed in 2x magnification, with blinking "ZOOM" displayed at the screen upper right, indicating that a ZOOM display is being conducted.

To cancel the ZOOM function, either select OFF in (1) or begin operation of range.

Up/Down --> ENT --> Up/Down (Select ON) --> ENT --> Up/Down & Left/Right --> ENT

ZOOM Setting
 (Select ZOOM) | (Move cross cursor)
 |--> (Select OFF) --> ENT -----
 ZOOM canceled

- Note 1) VRM2 and EBL2 do not follow the ZOOM function during a floating state.
- Note 2) Normal screen returns when you change the range scale.
- Note 3) ZOOM function is usable only in PPI screen.
- Note 4) ZOOM function is unusable in OFF-C.
- Note 5) Center of ZOOM can be set any desired position within the set range.

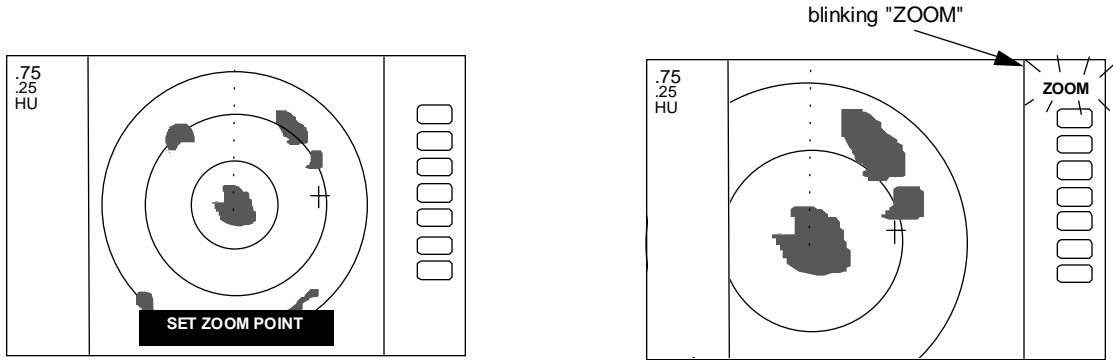

5.5.3.8 Increasing sensitivity (S/L)

The pulse width is automatically changed as you change the range. However, if you want to increase sensitivity, you can choose sensitivity from two pulse widths. The short pulse (SHORT) gives you sharp images with high distance resolution. The long pulse (LONG) provides high sensitivity and shows targets in large size for easy identification although distance resolution is reduced.

- (1) Use the up-down cursor keys to select S/L from among the pull-down display items, and press the "ENT" key.
- (2) Select Pulse length (SHORT or LONG) using the up-down cursor keys from the SHORT/LONG display beside the S/L item
- (3) The setting will be completed when the "ENT" key is pressed after the selection.

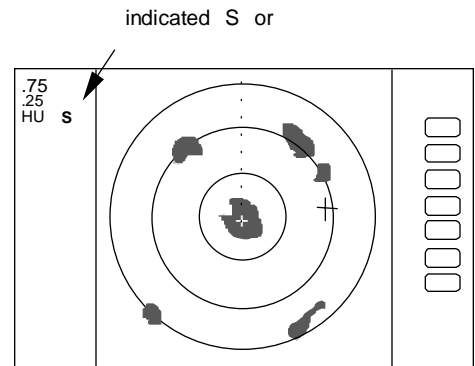

Up/Down --> ENT --> (Select SHORT) ----->
 ENT Set to short pulse
 |--> (Select LONG) --> ENT ----- Set to long pulse

5.5.4.5.2 Changing the content of settings 1(PRESET1)

- (1) When PRESET1 is selected from CUSTOM items and the "ENT" key is pressed, the PRESET1 screen (See chart below) appears.
- (2) Select items with up-down keys and contents with left-right keys. The selected items will be enclosed by square frames and the contents will appear in reversed display. (a)
Repeat this operation when multiple settings are to be made.

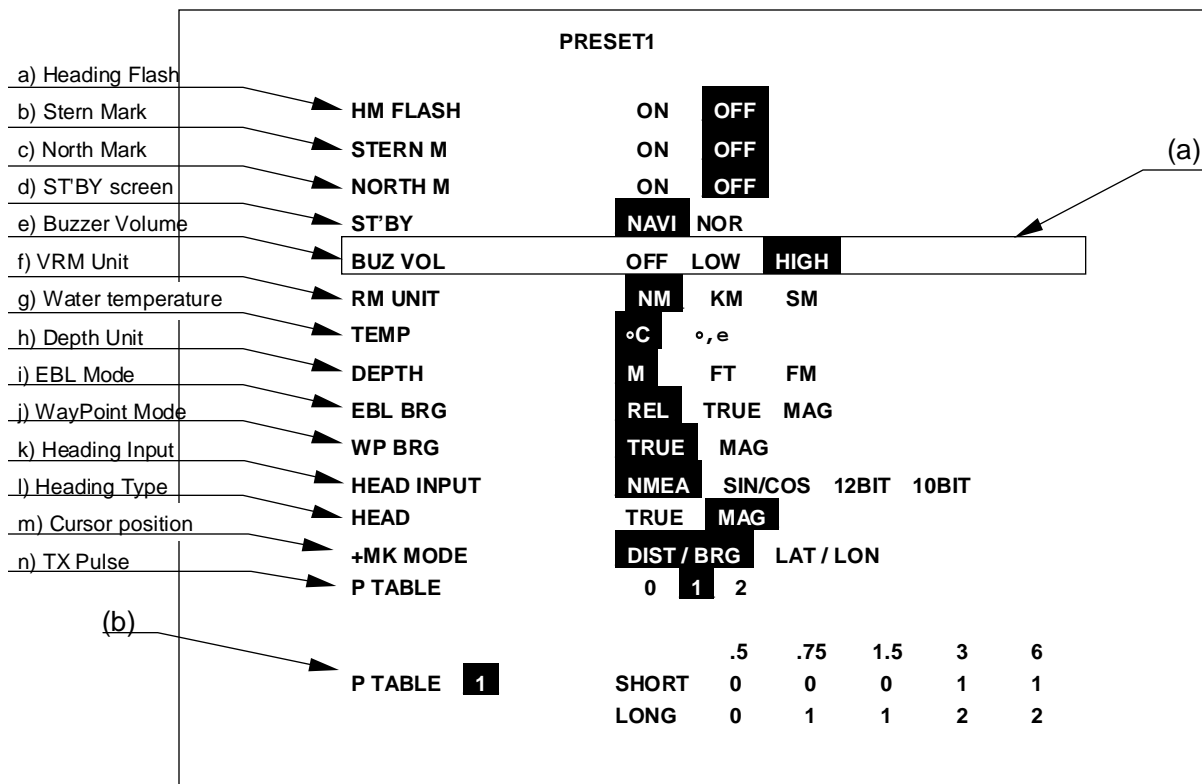

- (3) After the setting is completed, exit from the PRESET1 screen with the "ENT" key.

Note) The contents will be displayed in (b) together with the numbers selected in P TABLE.

- • Heading Flash on
Each revolution of the antenna turns the heading marker on and off.
- b) Stern Mark
Display/non-display of the stern line
- c) North Mark
Display/non-display of the north mark
- • ST'BY screen
Setting the screen display in stand-by
NAVI: Navigation Data screen
NOR: Normal screen
- e) Buzzer Volume
Setting the volume of the buzzer

- VRM Unit Setting VRM unit
 - NM: Nautical mile
 - KM: Kilometer
 - SM: Statute mile
- g) Water temperature Setting water temperature unit
 - °C: Celsius
 - F: Fahrenheit
- h) Depth Unit Setting Depth unit
 - M: Meter
 - FT: Feet
 - FM: Fathom
- i) EBL Mode Setting Mode of EBL
 - REL: Relative bearing from HM bearing
 - TRUE: True bearing
 - MAG: Magnetic bearing
- j) WayPoint Mode Setting WayPoint bearing mode
 - TRUE: True bearing
 - MAG: Magnetic bearing
- k) Heading Source Setting Heading source;
 - NMEA
 - SIN/COS: Compass Data with SIN/COS signal
 - 12BIT: Compass Data with 12bits serial signal
 - 10BIT: Compass Data with 10bits serial signal
- l) Heading Type Heading Information Type setting
 - MAG: Magnetic bearing
 - TRUE: True bearing
- m) Cross cursor position display Mode
 - DIST/BRG: Range and Bearing indication
 - LAT/LON: Latitude and Longitude indication
- n) Transmitting pulse width Pulse setting for Range (Note:)

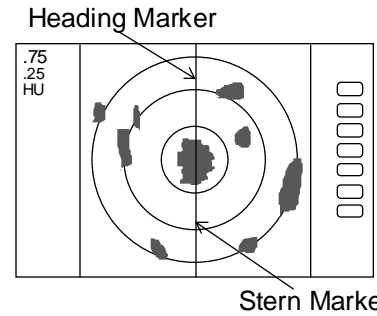

Note: P TABLE

	PUSLE TYPE	•0.25 NM	0.5 NM	0.75 NM	1.5 NM	3 NM	6 NM	•12 NM
P TABLE 0	SHORT	0	0	0	0	0	1	2
	LONG	0	0	0	1	1	2	2
P TABLE 1	SHORT	0	0	• 0	0	1	1	2
	LONG	0	0	1	1	2	2	2
P TABLE 2	SHORT	0	0	0	1	1	1	2
	LONG	0	1	1	2	2	2	2

Note • RA40C Pulse width 0 : 0.12 uS, 1 : 0.3 uS, 2 : 0.8 uS
 PA41X/42X Πυλσε ωιδτη 0 : 0.08 uS, 1 : 0.25 uS, 2 : 0.8 uS

5.5.4.5.3 Changing the content of settings 2 (PRESET2)

Refer to the section, “Changing the content of setting 1(PRESET1)”.

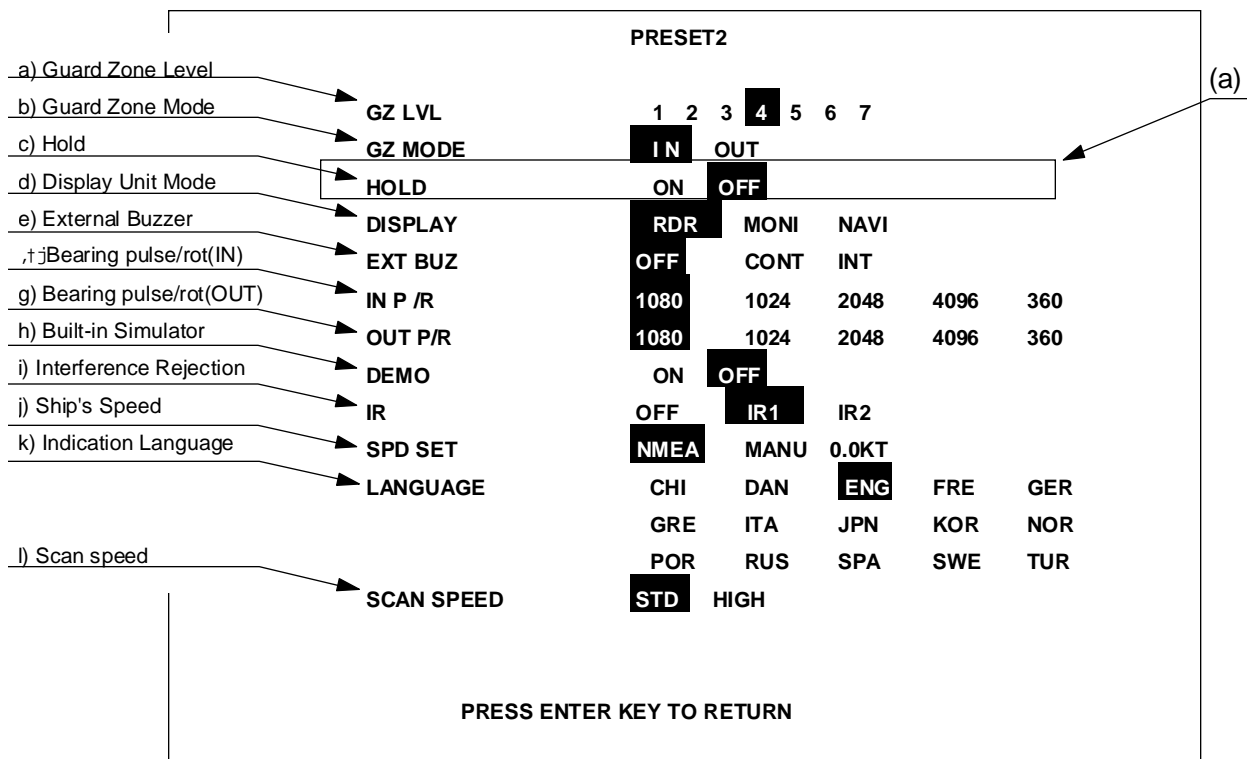

- a) Guard Zone Level Guard Zone Detection Level setting
1: High Sensitivity, .. 7: Big Target Only
- b) Guard Zone Mode Guard Zone Detection Mode setting
IN: Detect Target in
OUT: Detect Target dissappear
- c) Hold Hold the radar picture for 30 seconds after switch to STBY
The EBL and VRM can be used in HOLD state.(Note1:)
- d) Display Unit Mode Display Unit Operation Mode setting
RDR: Radar mode(normal)
MONI: Monitor mode(for slave display use)
NAV: Navigation mode(for DATA indicator use)
- e) External Buzzer External Buzzer control setting
OFF: Buzzer off
CONT: Continuous tone
INT: Intermittent tone
- f) Bearing pulse/rot.(IN) Change the setting when connected to the other type of radar
- g) Bearing pulse/rot.(OUT) Change the setting when connected to the other type of radar
- h) Built-in simulator switch for Demonstration
- i) Interference Rejection Reject the interference from the other radar
OFF: IR OFF
IR1: ON level 1
IR2: ON level 2

j) Ship's Speed

Own ship's speed setting

NMEA: Data input from NMEA port

MANU: Set ship's speed with manual

Set the Speed with control knob.

k) Indication Language

Select the language for MENU and SOFT KEY(Note2:)

l) Scan Speed

Scanning speed setting

STD: Standard

HIGH: High speed

(The setting can be changed only on stand-by state.

)

Note1: HOLD function

POWER • POWER key to press

HOLD is function which you want to hold the currently displayed radar screen conditions while standby state. After finished operation such as EBL, VRM about 30 seconds, the screen return to standby screen.

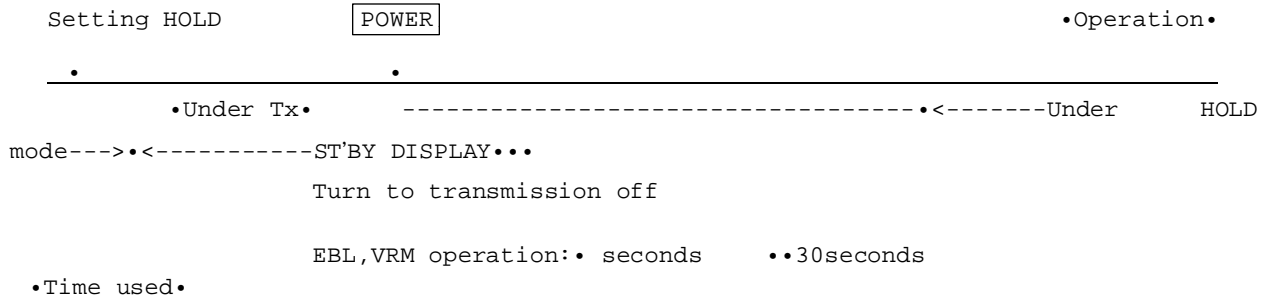

NOTE) EBL and VRM function is usable in HOLD state.

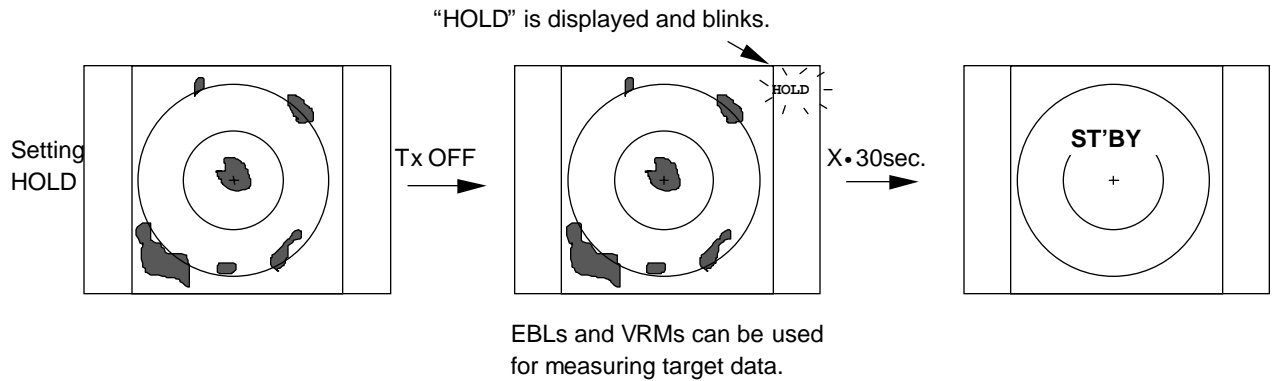

Note 2: 15 languages

- CHI : Chinese
- DAN : Danish
- ENG : English
- FRE : French
- GER : German
- GRE : Greek
- ITA : Italian
- JPN : Japanese

- KOR : Korean
- NOR : Norwegian
- POR : Portuguese
- RUS : Russian
- SPA : Spanish
- SWE : Swedish
- TUR : Turkish

5.5.4.5 Changing the content of the setting (CUSTOM)

Note) Items in CUSTOM are for conducting settings and adjustments at the time of installation, which need not be conducted normally.

-Common operations for CUSTOM

Use the up-down cursor keys to select CUSTOM after "the common operations for the SETUP" menu, and press either the "ENT" key.

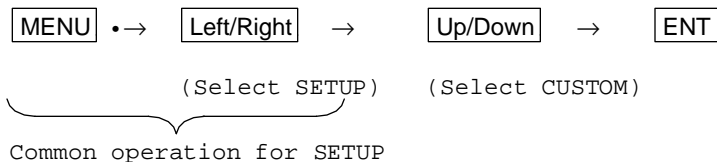

When the above operations have been conducted, 4 items, namely "KEY ASSIGN", "PRESET1", "PRESET2" and "ADJUST", are displayed beside the CUSTOM item.

Further explanation concerning the CUSTOM menu items will be done on the assumption that the above "common operations for CUSTOM" have already been conducted.

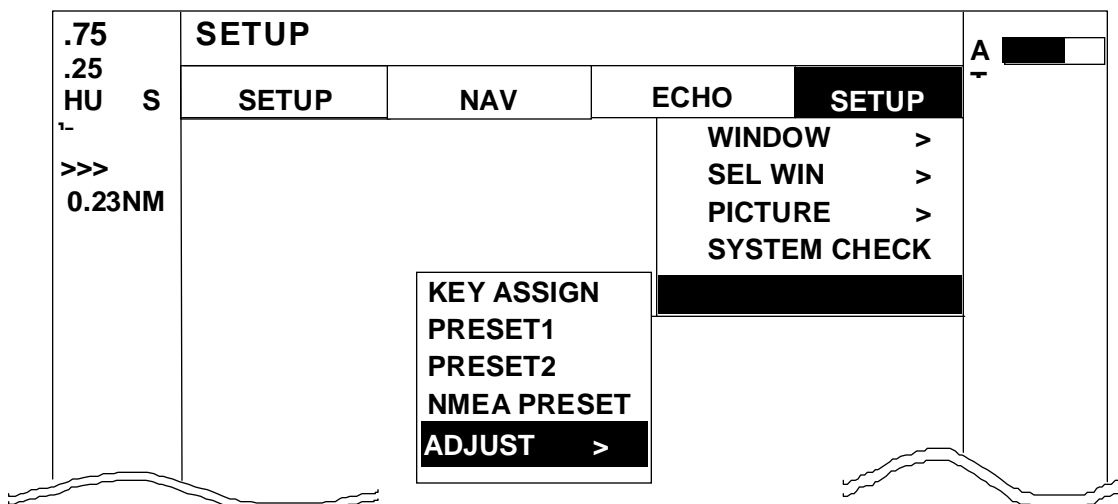

5.5.4.5.1 Changing the settings of soft keys (KEY ASSIGN)

Conducting alterations and new settings for the functions of keys with number displays of 1-7.

(1) Screen display for the setting

When KEY ASSIGN has been selected with the up-down cursor keys from among the CUSTOM items and the "ENT" key is pressed, the setting screen is displayed. (See chart below)

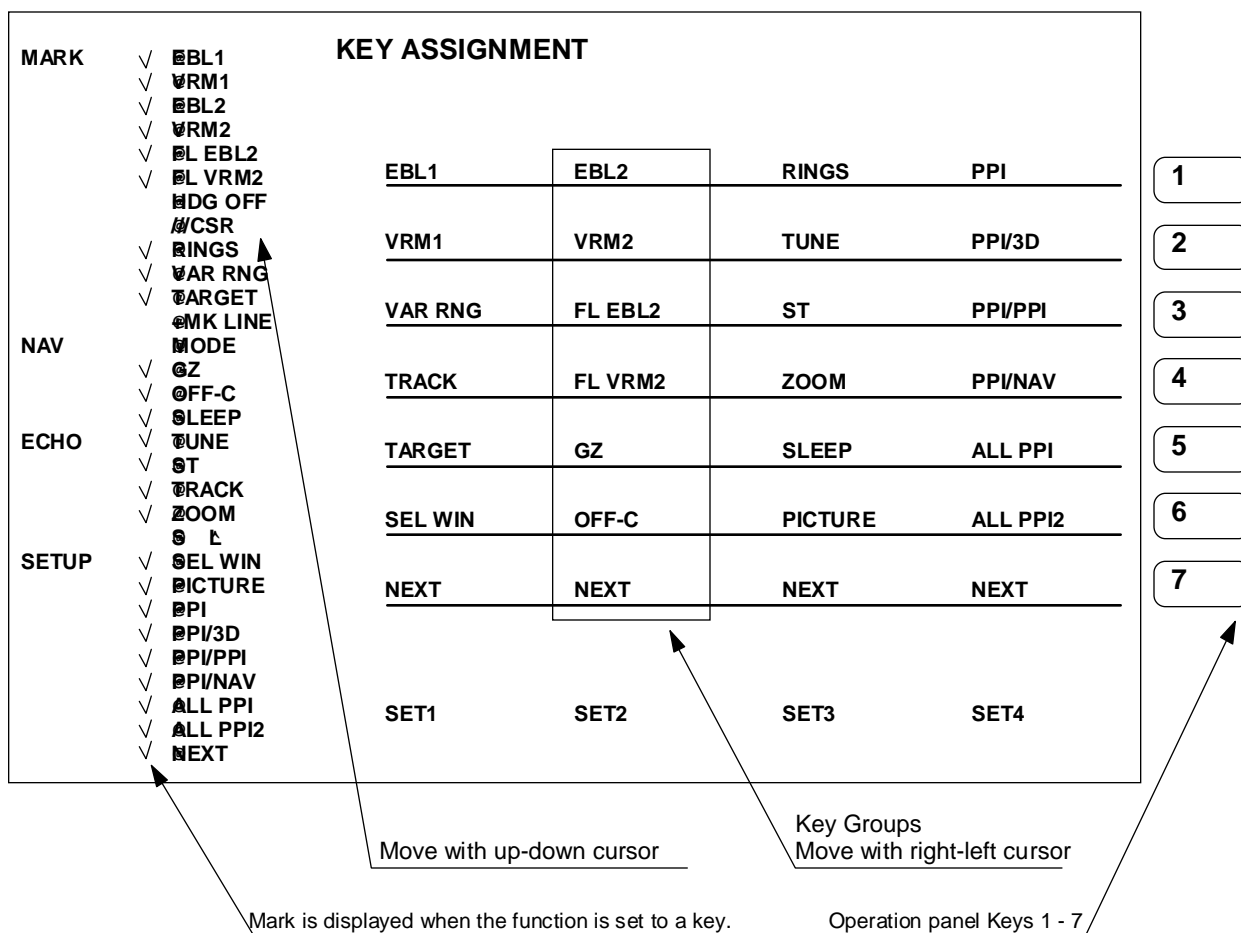

Soft Key Setting Screen

(2) Selecting functions

Reverse the items to be set using the up-down cursor keys. (The items become reverse in accordance with the moving cursor.)

(3) Key settings

(3)-1 Making new settings (Example 1)

For allocating the selected item to a soft key, press the key to be allocated. The selected item will be displayed beside the key, which indicates that the setting has been conducted.

(3)-2 Changing the function of a key with an preset function (Example 2)

When the allocated key is pressed, its function will be altered to the one selected in (1) above and the previous function will be canceled.

The current settings for SET1-4 will be displayed below NEXT. In order to switch the settings SET1-4, use the right-left cursor keys. (Double settings (setting 1 item for more

than 1 key) are possible.)

When settings are to be conducted for more than 1 key, repeat the operations (3)-1 to (3)-2.

(Example 3)

(4) Completing the setting

After the setting has been finished, press the ENT key to exit from KEY ASSIGNMENT.

Example of an operation

(The process up to the selection of KEY ASSIGNMENT from the SETUP menu is omitted. Only the process after the above chart will be described.)

Example 1) Altering OFF-C allocated to key 6 in setting 2 to HDG OFF.

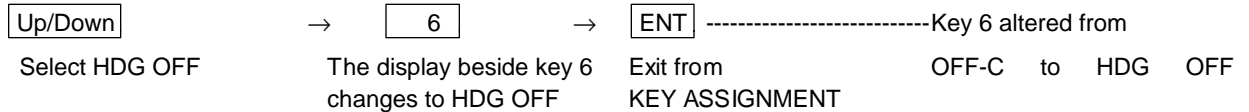

Example 2) Re-allocate SEL WIN to key 1 in setting 2.

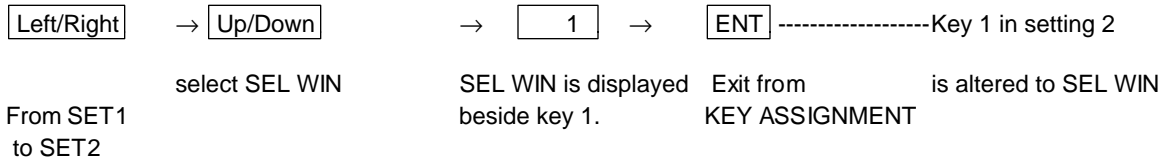

Example 3) Alter key 1 in setting 1 from ST to HDG OFF and then reset key 1 in setting 2 as SEL WIN.

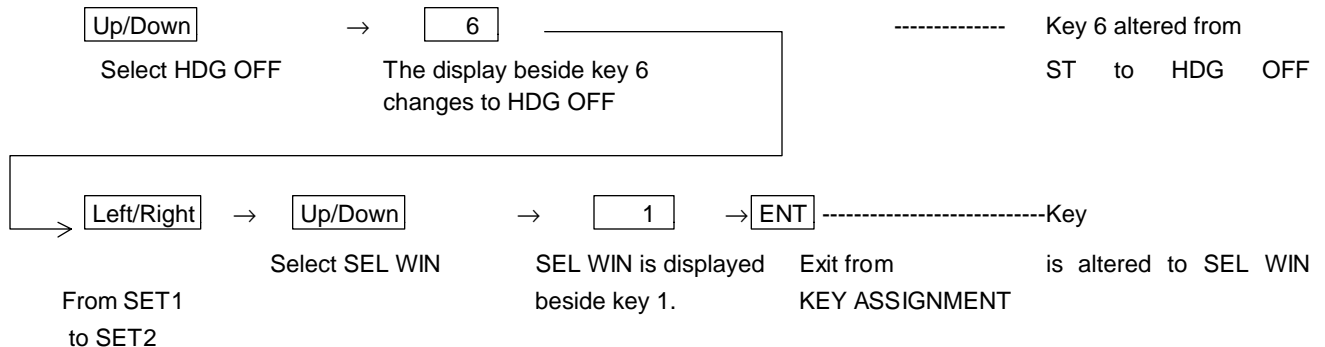

5.5.4.5 Changing the content of the setting (CUSTOM)

Note) Items in CUSTOM are for conducting settings and adjustments at the time of installation, which need not be conducted normally.

-Common operations for CUSTOM

Use the up-down cursor keys to select CUSTOM after "the common operations for the SETUP" menu, and press either the "ENT" key.

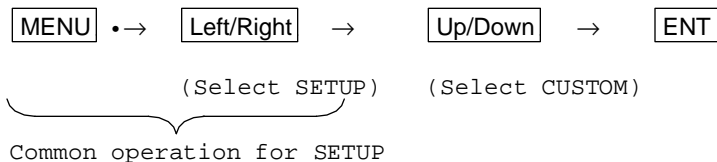

When the above operations have been conducted, 4 items, namely "KEY ASSIGN", "PRESET1", "PRESET2" and "ADJUST", are displayed beside the CUSTOM item.

Further explanation concerning the CUSTOM menu items will be done on the assumption that the above "common operations for CUSTOM" have already been conducted.

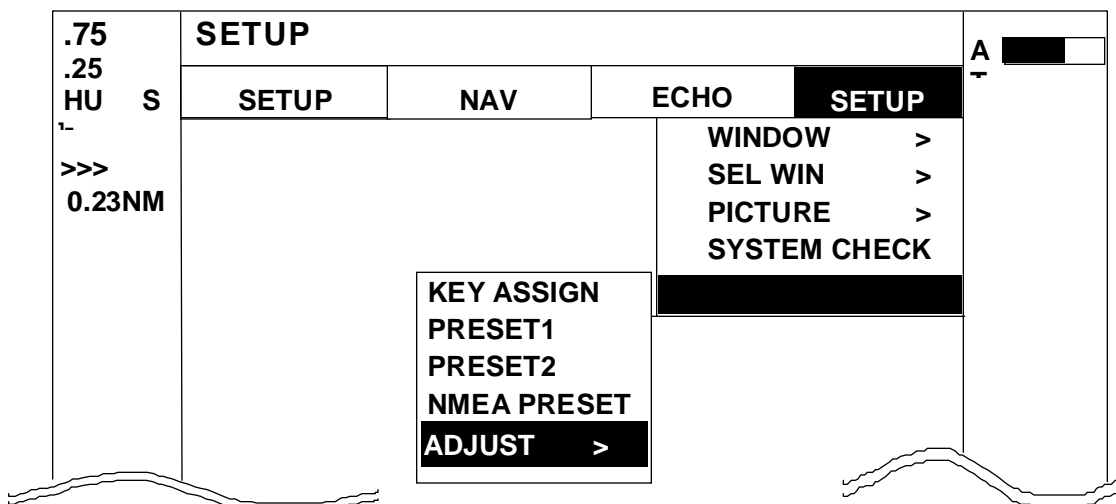

5.5.4.5.1 Changing the settings of soft keys (KEY ASSIGN)

Conducting alterations and new settings for the functions of keys with number displays of 1-7.

(1) Screen display for the setting

When KEY ASSIGN has been selected with the up-down cursor keys from among the CUSTOM items and the "ENT" key is pressed, the setting screen is displayed. (See chart below)

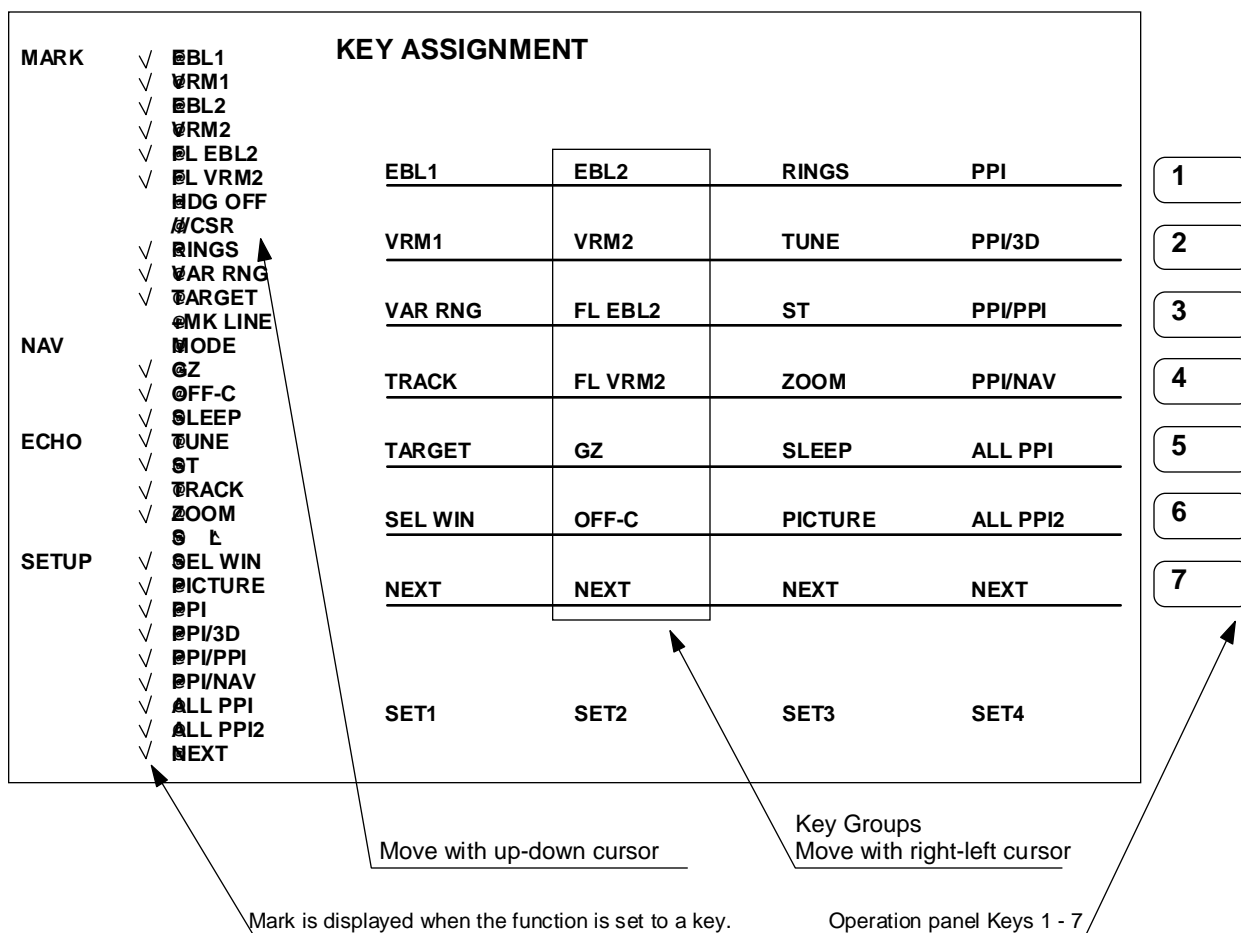

Soft Key Setting Screen

(2) Selecting functions

Reverse the items to be set using the up-down cursor keys. (The items become reverse in accordance with the moving cursor.)

(3) Key settings

(3)-1 Making new settings (Example 1)

For allocating the selected item to a soft key, press the key to be allocated. The selected item will be displayed beside the key, which indicates that the setting has been conducted.

(3)-2 Changing the function of a key with an preset function (Example 2)

When the allocated key is pressed, its function will be altered to the one selected in (1) above and the previous function will be canceled.

The current settings for SET1-4 will be displayed below NEXT. In order to switch the settings SET1-4, use the right-left cursor keys. (Double settings (setting 1 item for more

than 1 key) are possible.)

When settings are to be conducted for more than 1 key, repeat the operations (3)-1 to (3)-2.

(Example 3)

(4) Completing the setting

After the setting has been finished, press the ENT key to exit from KEY ASSIGNMENT.

Example of an operation

(The process up to the selection of KEY ASSIGNMENT from the SETUP menu is omitted. Only the process after the above chart will be described.)

Example 1) Altering OFF-C allocated to key 6 in setting 2 to HDG OFF.

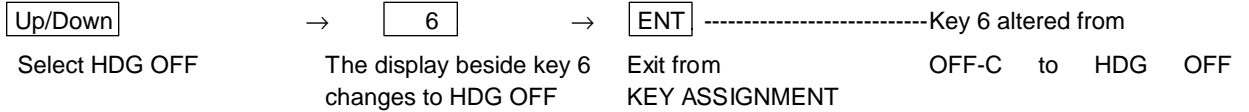

Example 2) Re-allocate SEL WIN to key 1 in setting 2.

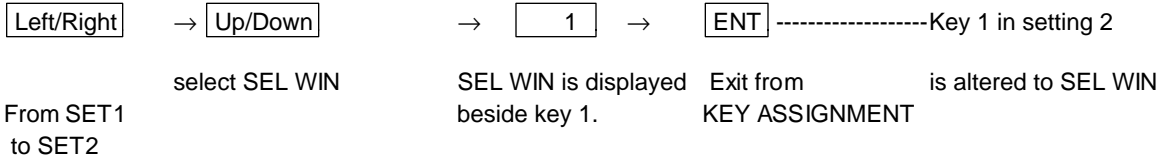

Example 3) Alter key 1 in setting 1 from ST to HDG OFF and then reset key 1 in setting 2 as SEL WIN.

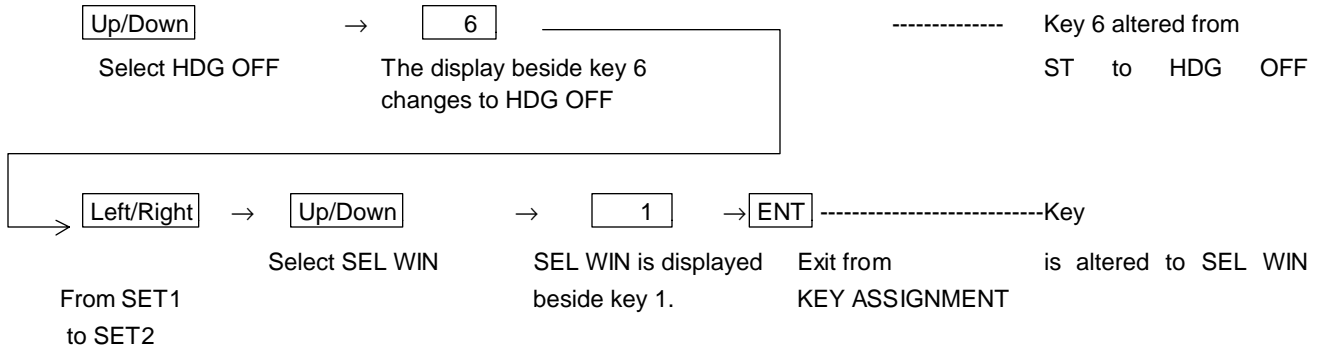

5.5.4 SETUP Menu

To be used for various settings and switching of the screen

• **Common operations for the SETUP menu** (Up to the point when "SETUP" menu is selected from the main menu)

Press the "MENU" key and select "SETUP" from the displayed 4 main menus using the left-right cursor. (The contents of the selected MENU will appear on a pull-down display in accordance with the movement of the left-right cursor.)

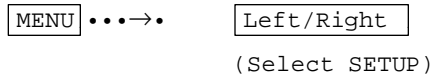

When the above-mentioned operations have been conducted, the items of the SETUP menu are vertically displayed. Further explanation about the SETUP menu will be conducted on the assumption that this "common operation for the SETUP menu" has already been completed.

5.5.4.1 Initiating the screen display (WINDOW)

A function to switch the display method of the screen. A selection can be made from among the 7 patterns of screen arrangements, from the ordinary PPI display to the 2-screen PPI display, etc.

- a) PPI screen
- b) PPI screen & SEMI3D screen
- c) PPI screen & PPI screen (Range can be operate in each screen.)
- d) PPI screen & Navigation screen
- e) All PPI screen (PPI, all the screen display.)
- f) All PPI screen & All PPI screen(PPI & PPI, all the screen display.)
- g) MOB screen

- (1) Use the up-down cursor keys to select WINDOW from among the pull-down display items, and press the "ENT" key.
- (2) Select a screen to be displayed with the up-down cursor keys from among the above 7 items that are displayed beside the WINDOW item.
- (3) The setting will be completed when the "ENT" key is pressed after the selection.

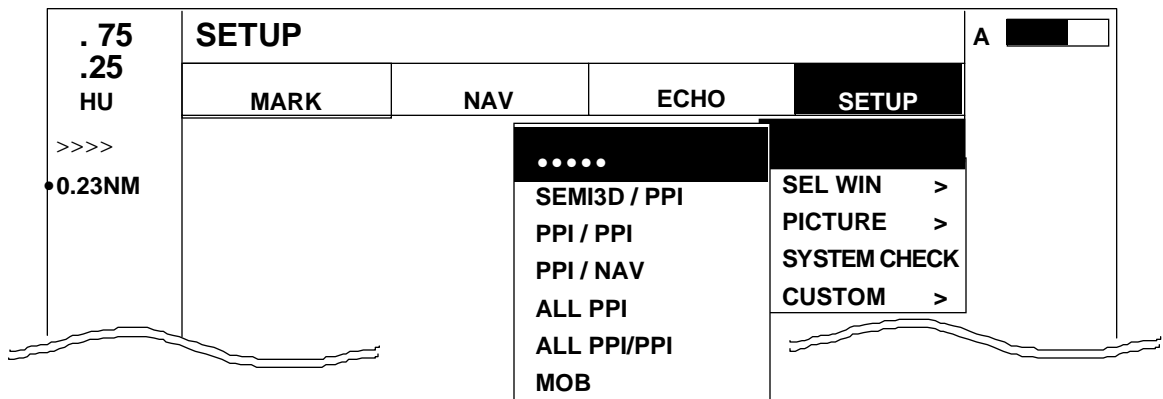

[Up/Down] → [ENT] → [Up/Down] → (Select PPI• → [ENT] •a•
 •select WINDOW• → [ENT] •b•
 → (Select PPI+SEMI3D•
 → (Select PPI+PPI• → [ENT] •c•
 → (Select PPI+NAV• → [ENT] •d•
 → (Select ALL PPI• → [ENT] •e•
 → (Select ALL PPI+PPI• → [ENT]
 •f•
 → (Select MOB• → [ENT] •g•

-Limitation of screen operation

SCREEN ITEM	...	PPI/SEMI3D PPI/NAV	PPI•PPI	ALL PPI	ALL PPI PPI	MOB
RANGE	•	•	•	•	•	×
VRM1•EBL1	•	•	•	×	×	×
VRM2•EBL2	•	•	•	×	×	×
FL VRM2•EBL2	•	×	×•	×	×	×
RINGS ON/OFF	•	•	•	•	•	×
ZOOM•OFF CENT	•	×	×	×	×	×
///CSR	•	•	•	•	•	×
HDG OFF	•	•	•	×	•	×
STERN M	•	•	•	•	•	×
NORTH M	•	•	•	•	•	×
GAIN•STC•FTC	•	•	•	×	×	×
TUNE	•	•	•	×	×	×
ST	•	•	•	×	×	×
GZ	•	•	•	×	×	×
SEL WIN	×	×	•	×	•	×
TXON/OFF	•	•	•	•	•	×

- • Independent control at time as two screen. •Switching the screen is necessary (SEL WIN)•
- • It becomes simultaneous control at the time as two screen.
- • It can be used only at the time of PPI screen.
- × • It can't be used.

- Screen modes and Operations

(a) PPI Screen

All functions can be used on this screen.

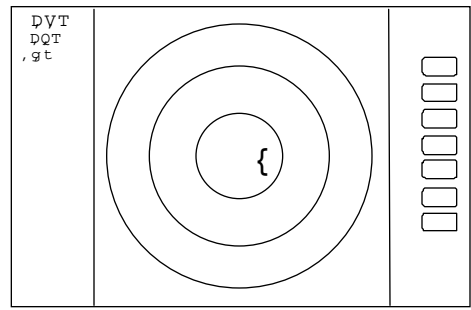

PPI Screen

(b) PPI/SEMI3D Screen

It becomes simultaneous control at the time as two screen.

Note: All controls, such as EBLs, VRMs effects both screen.

The ZOOM, OFF-C, FL EBL2, and FL VRM2 could not be used on this mode. The "SEMI3D" screen displays the center as ship's heading always.

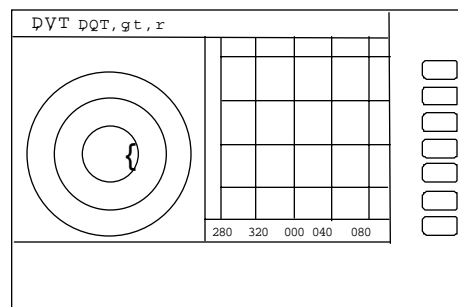

PPI/SEMI3D Screen

(c) PPI/PPI Screen

The radar picture is refreshed two antenna scanning for each PPI screen. Un-refreshed screen picture is holded during the time.

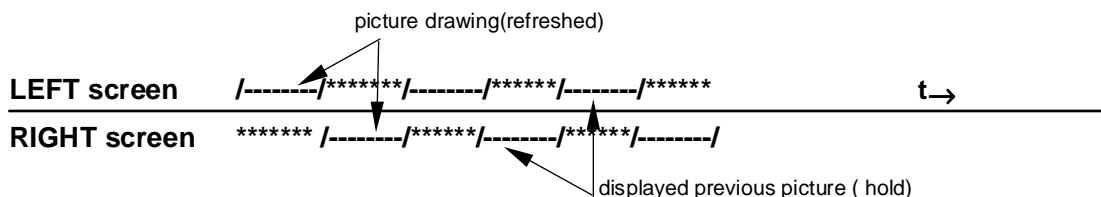

Note: The radar picture is refreshed with two scanning interval for each screen. Right screen picture is holded during refreshing left screen, left screen holded during refreshing right screen. When your ship navigates in high speed, use PPI screen to get fast refreshing picture.

Note: Functions ZOOM, OFF-C, FL-EBL2, and FL-VRM2 can not be used on this screen.

Note: The function RANGE, GAIN, STC, FTC, and GZ can be used for each screen independently. The screen selected in "SEL WIN" that the range indicator displayed in reverse can be controlled.

Note: The cross cursor displayed only on selected screen.

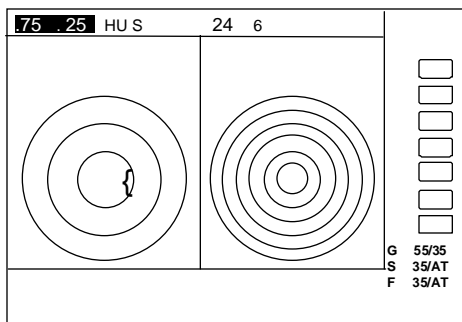

LEFT screen selected

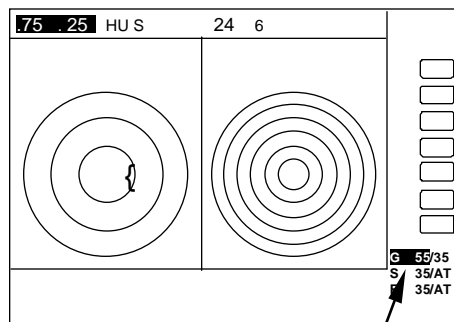

GAIN adjustment for LEFT screen

Left GAN indicates in reverse

-Operation

- a) Changing RANGE of LEFT screen
 - 1) When the RIGHT range indicator displayed in reverse, change to LEFT screen with "SEL WIN" function.
 - 2) Press "RANGE UP" or "RANGE DOWN" key to change the LEFT screen RANGE.

b) Adjusting GAIN of LEFT screen.

- 1) When the RIGHT range indicator displayed in reverse, change to LEFT screen with "SEL WIN" function.
- 2) Press the "GAIN" key, "G50" will displayed in reverse and ready for adjusting GAIN.
- 3) Adjust GAIN with the control knob.
Adjust STC and FTC in a same manner as GAIN.

Note: During adjustment of GAIN, STC, or FTC, radar picture refreshing is fixed to the adjusting screen. Approximately 5 seconds elapsed after adjustment, radar picture refreshing is return to normal.

c) Determining the distance with VRM1 on LEFT screen.

- 1) When the RIGHT range indicator is displayed in reverse, change to LEFT screen with "SEL WIN" function.
- 2) Press the "VRM1" key, "0.00NM" will be displayed in reverse and ready for adjusting VRM1.
- 3) Determining the distance with the control knob.

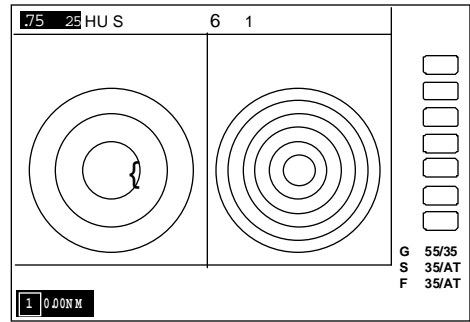

Determining the distance with VRM1 on LEFT screen

Note: If operate the VRM1 on the RIGHT screen, VRM1 will move to the RIGHT screen.

Operate VRM2, EBL1, or EBL2 in a same manner as VRM1.

(d) PPI/NAV Screen

Note: The ZOOM, OFF-C, FL EBL2, and FL VRM2 can not be used on this screen.

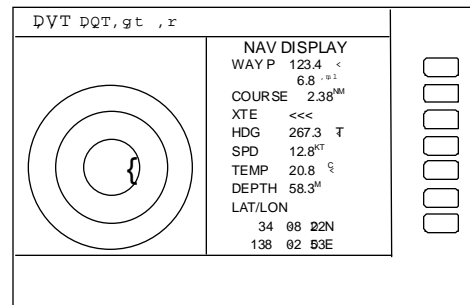

(e) ALL PPI Screen

Note1: The RANGE, RINGS interval, and Display mode are displayed on the upper-left of the screen.

Note2: When press the key except "MENU", "RANGE UP/DOWN", "BRILL", and "POWER", return to PPI screen.

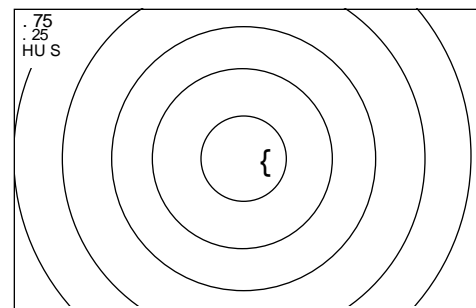

ALL PPI screen

(f) ALL PPI/PPI Screen

Note1: The RANGE, RINGS interval, and Display mode are displayed on the top of the screen.

Note2: When press the key except "MENU", "RANGE UP/DOWN", "BRILL", and "POWER", return to PPI/PPI screen.

Note3: The radar picture is refreshed with two scanning interval for each screen. Right screen picture is holded during refreshing left screen, left screen holded during refreshing right screen. When your ship navigates in high speed, use PPI screen to get fast refreshing picture.

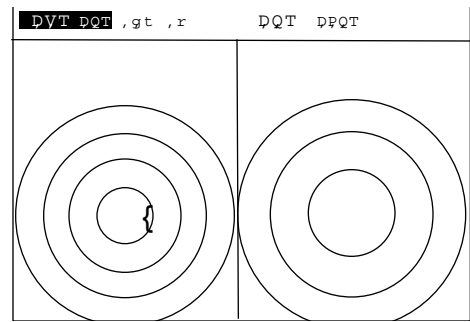

ALL PPI PPIscreen

(g) MOB Screen

The MOB key has been pressed, the MOB position and ship's position are displayed. If not, MOB position will be displayed with bars(--.-)

Press MOB key to clear the MOB position and return to previous screen. Press ENT key to return previous screen with keeping the MOB position data.

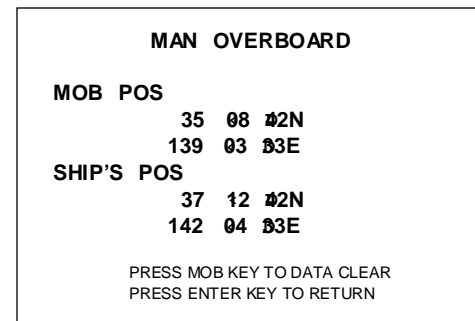

5.5.4.2 Switching screens on PPI/PPI screen (SEL WIN)

Switching to the desired screen for activation on a PPI/PPI screen display.

The "SEL WIN" function is switches the activated screen to effect the operation such as, RANGE, GAIN, STC, FTC, VRM1/2, EBL1/2, and guard zone. The range indicator of activated screen is displayed in reverse.

When "SEL WIN" is selected with the up-down cursor keys from among the pull- down display items and the "ENT" key is pressed, activated screen will be changed to the opposite screen.

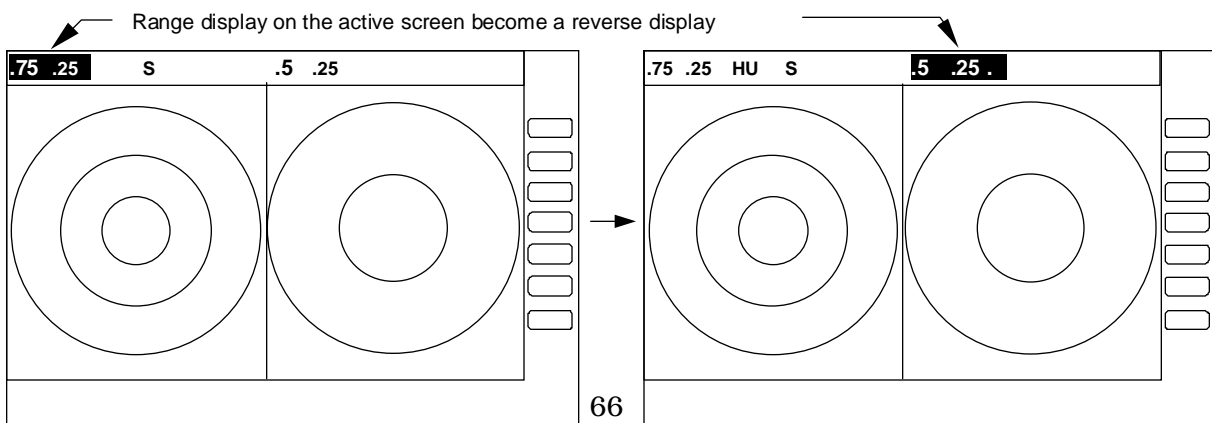
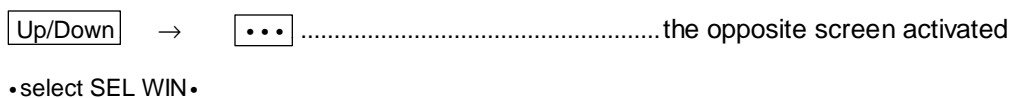

5.5.4.3 Changing the color of screen (PICTURE)

Changing the color of screen depending on weather and day / night environment conditions will be effective for easy viewing .

When "PICTURE" is selected with the up-down cursor keys from among the pull-down display items, select "DAY" and press "ENT" key to set to day display. Night display appears if "NIGHT" is selected

Up/Down → ENT → Up/Down → (select DAY • → ENT → day display
•select PICTURE • → (select NIGHT • → ENT → night display

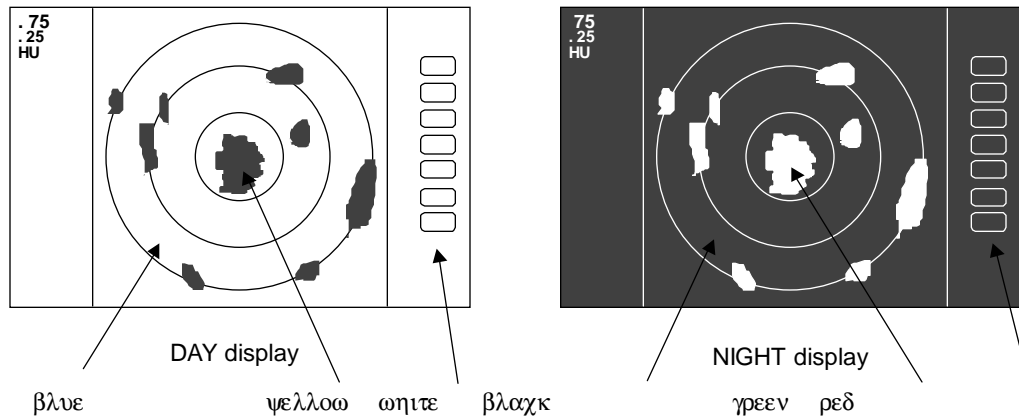

5.5.4.4 Fault Diagnosis by Self Check •SYSTEM CHECK)

Verifying the problem point by SYSTEM CHECK when, for example, some abnormality has occurred.

- (1) Select SYSTEM CHECK from the pull-down display items using up-down cursor key, and press the "ENT" key.
- (2) The system check screen will appear. While watching the screen , check the following:
 - i) Whether all items are marked "OK". (If any item is marked "NG", the indicated location may be faulty.)
 - ii) Press a front-panel key and see if the corresponding display on the screen is highlighted.
 - iii) Turn the control knob and see if the lower-right indicator move to right or left.
- (3) Press the POWER key to return to the previous screen

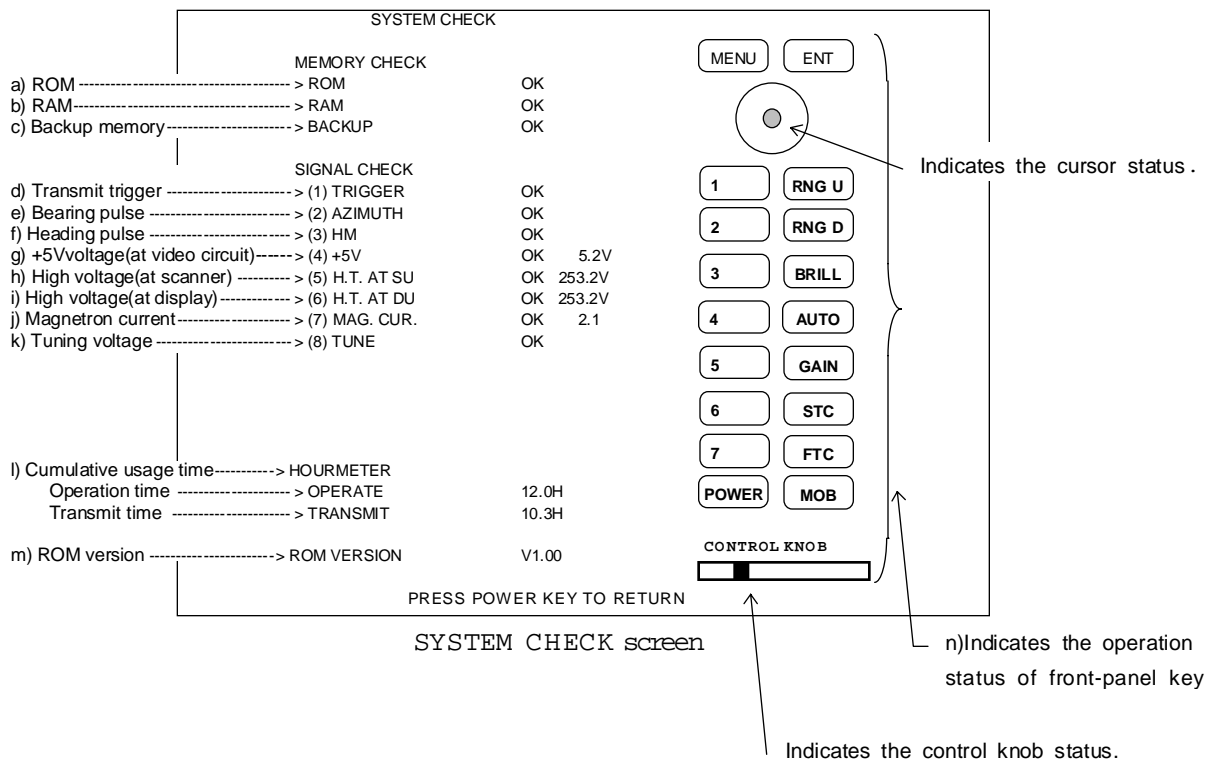

- a) **ROM**----- Indicates the ROM status.
- b) **RAM** ----- Indicates the RAM status.
- **Backup memory**----- Indicates the backup memory status.
- **Transmit trigger** ----- Indicates the signal line status for the trigger signal sent from the scanner unit.
- **Bearing pulse** ----- Indicates the signal line status for the bearing signal sent from the scanner unit.
- f) **Heading pulse**----- Indicates the signal line status for the bow signal sent from the scanner unit.
- g) **+5V voltage**----- Indicates the reference voltage status of the video circuit and its voltage value.
 (at video circuit) (normally about 5 V)
- h) **High voltage(at SU)**----- Indicates the status of th high voltage supplied from the display unit to the scanner unit and its voltag value (normally about 250 V) at scanner unit.
- i) **High voltage(at DU)** ----- Indicates the status of th high voltage supplied from the display unit to the scanner unit and its voltag value (normally about 250 V) at display unit.
- j) **Magnetron current** ----- Indicates the status of the anode current flowing in the magnetron and its current value.
- k) **Tuning voltage** ----- Indicates the status of the voltage used for tuning and its voltage value.
- l) **Cumulative usage time** ---- Indicates the cumulative time your radar is used.
OPERATE : Duration of time during which the power supply is turned on.
TRANSMIT : Duration of time transmitting.
- m) **ROM version** ----- Indicates the ROM software version.
- n) **Front-panel keys**----- As you press any front-panel key when the **SYSTEM CHECK** screen is on, the corresponding key is highlighted on the screen by displaying it in reverse video.

5.5 MENU Operation

List of MENU

List of Main Menu

MARK (MAIN-MENU)		NAV (MAIN-MENU)		ECHO (MAIN-MENU)		SETUP (MAIN-MENU)	
EBL1	ON/OFF	MODE	HU/HS/NU/CU/TM •MANU/NMEA•	GAIN	AUTO/MAN	WINDOW	PPI/SEM3D+PPI/ PPI+PPI/PPI+NAV/ ALLPPI/ALL PPI+PPI/MOB
VRM1	ON/OFF			STC	AUTO/MAN/HARBOR		
EBL2	ON/OFF	GZ	ON/OFF	FTC	AUTO/MAN		
VRM2	ON/OFF	OFF-C	ON/OFF	TUNE	AUTO/MAN	SEL WIN	
FL EBL2	ON/OFF	SLEEP	OFF/5min/10min/ 15min	ST	OFF/ST1/ST2	PICTURE	DAY/NIGHT
FL VRM2	ON/OFF			TRACK	OFF/15SEC/30SEC/ 1MIN/3MIN/6MIN/ CONT	SYSTEM CHECK	
HDG OFF	OFF			ZOOM	ON/OFF	CUSTO M	KEY ASSIGNMENT PRESET1 (SUB-MENU) PRESET2 (SUB-MENU) ADJUST (SUB-MENU)
///CSR	ON/OFF			SL	SHORT/LONG		
RINGS	ON/OFF						
VAR RNG	ON/OFF						
TARGET							
+MK LINE	ON/OFF						

List of Custom Menu

PRESET1 (SUB-MENU)		PRESET2 (SUB-MENU)	
HM FLSH	ON/OFF	GZ LEVEL	1-7
STERN M	ON/OFF	GZ MODE	IN/OUT
NORTH M	ON/OFF	HOLD	ON/OFF
ST'BY	NAVI/NOR	DISPLAY	RDR/MONI/NAV
BUZ VOL	OFF/LOW/HIGH	EXT BUZ	OFF / CONT / INT
RM UNIT	NM / KM / SM	IN P/R	1080/1024/2048/4096/360
DEPTH	M / FT / FM	OUT P/R	1080/1024/2048/4096/360
TEMP	°C / F	DEMO	ON / OFF
EBL BRG	REL / TRUE / MAG	IR	OFF / IR1 / IR2
WP BRG	TRUE / MAG	SPD SET	NMEA / MANU 0.0 KT
HEAD INPUT	NMEA / SIN•COS /12BIT / 10BIT	LANGUAGE	15 countries
HEAD	TRUE / MAG	SCAN SPEED	STD / HIGH
+MK MODE	DIST/BRG•/•LAT/LON		
P TABLE	0 - 2		

ADJUST (SUB-MENU)	
TIMING ADJ	
HEAD ADJ	
TUNING CAL.	
ANTENNA	1-9
GAIN	1-30
STC	1-16

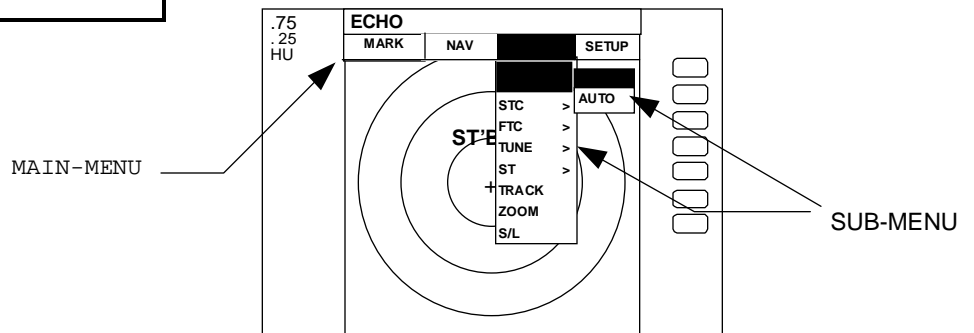

5.5.1 Mark Menu

xxx •keys to press

Setting for markers and cursors

•Common operations for the MARK menu

(Up to the point when "MARK" menu is selected from the main menu)

Press the "MENU" key and select "MARK" from the displayed 4 main menus using the left-right cursor. (The contents of the selected MENU will appear on a pull-down display in accordance with the movement of the left-right cursor.)



Further explanation about the MARK menu will be conducted on the assumption that this "common operation for the MARK menu" has already been completed.

5.5.1.1 Bearing measurement (EBL1)

- (1) Select EBL1 from the pull-down display items using the up-down cursor key, and press the "ENT" key.
- (2) When the ON/OFF sign is displayed beside the EBL1 item, select ON with the up-down cursor keys and press the "ENT" key.

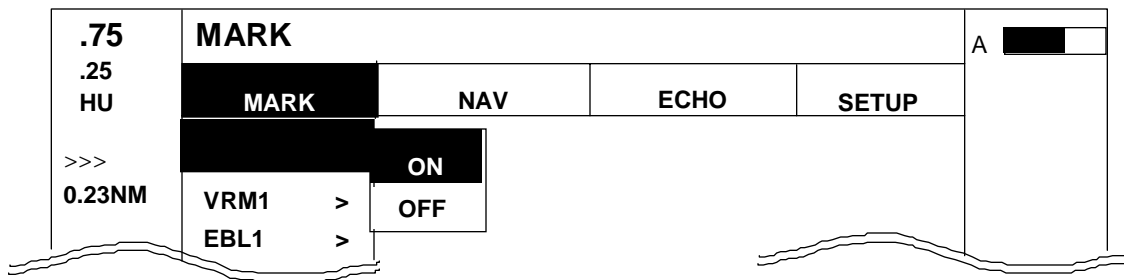

- (3) When the "ENT" key is pressed, electric bearing line (EBL1) appears and the angle from the direction of the ship's head which is set at 0 degree will appear in a reverse display at the lower left of the screen.
- (4) Place the marker on the center of the target with the control knob and read the bearing. Then, the display setting for EBL1 will be completed either (a)with the EBL1 display still on the screen if the "ENT" key is pressed, or (b)without the EBL1 display if the "MENU" key is pressed. (c)Pressing another function key will lead to the function of that key with the EBL1 display still on the screen.

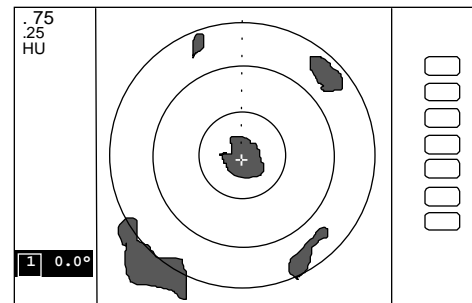

Note: • **1** xxx•xφ indicates EBL1.

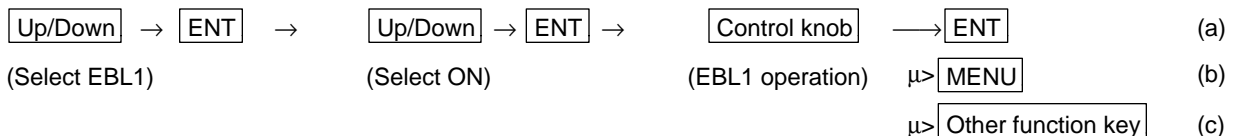

Note: The displayed EBL angle is relative to heading or true to north, depends on the setting of "EBL BRG" in the "SETUP" menu.

5.5.1.2 Determining the distance (VRM1)

- (1) Select VRM1 from the pull-down display items using the up-down cursor key, and press either the "ENT" key.
- (2) When the ON/OFF sign is displayed beside the VRM1 item, select ON with the up-down cursor keys and press the "ENT" key.
- (3) When the "ENT" key is pressed, the variable range marker1 (VRM1) and the distance in a reverse display appears at the lower left of the screen (See Note), and the display is set for VRM1.
- (4) Place the marker on the front edge of the target with the control knob and read the distance. Then, the display setting for VRM1 will be completed either (a)with the VRM1 display still on the screen if the "ENT" key is pressed, or (b)without the VRM1 display if the "MENU" key is pressed. (c)Pressing another function key will lead to the function of that key with the VRM1 display still on the screen.

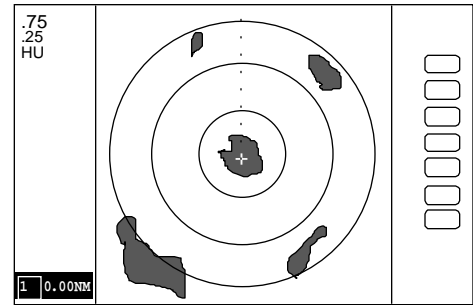

(a)

(Select VRM1)

(Select ON) (VRM1 operation)

μ>

MENU

(b)

μ> Other function key

(c)

Note: 1 xx.xx NM indicates VRM1.

5.5.1.3 Bearing measurement (EBL2)

Refer to the section "Bearing measurement (EBL1)".

The "EBL2" will appear in a reverse display at the lower right of the screen.

Note: • 2 xxx.xφ indicates EBL2.

5.5.1.4 Determining the distance (VRM2)

Refer to the section "Determining the distance (VRM1)".

The "VRM2" will appear in a reverse display at the lower right of the screen.

Note: 2 xx.xx NM indicates VRM2.

5.5.1.5 Measuring the distance or angle between two points (FL EBL2, FL VRM2)

Determining the distance (VRM2)

(a) Preparation for the measurement

- (1) Use the up-down cursor keys to select FL VRM2 from among the pull-down display items, and press the "ENT" key.
- (2) Use the up-down cursor keys to select ON from the ON/OFF display beside the FL VRM2 items, and press the "ENT" key. "SET START POINT" is displayed and a small cross mark

appears. (Once this is set, the "ON" state continues unless changes are made.)

→ → → ----- FL VRM2 is turned ON and
 (Select FL VRM2) (Select ON) the small cross mark appears.

(b) Setting a reference point for measurement of the distance

Use the left-right and up-down cursor keys to place the small cross mark on one of the two echoes whose distance will be measured, and press the "ENT" key.

& → ----- Criterion of the reference point is set.
 (Place the cross cursor on an echo)

(c) Measuring

Perform the operations in the above mentioned "Common operation for the MARK menu" and "measuring the distance(VRM2)", and place the VRM2 on another echo.

VRM2 is displayed on the screen around the placed fixed cross cursor.

" xx. xNM" which is displayed at the lower right will be the distance between the two points.

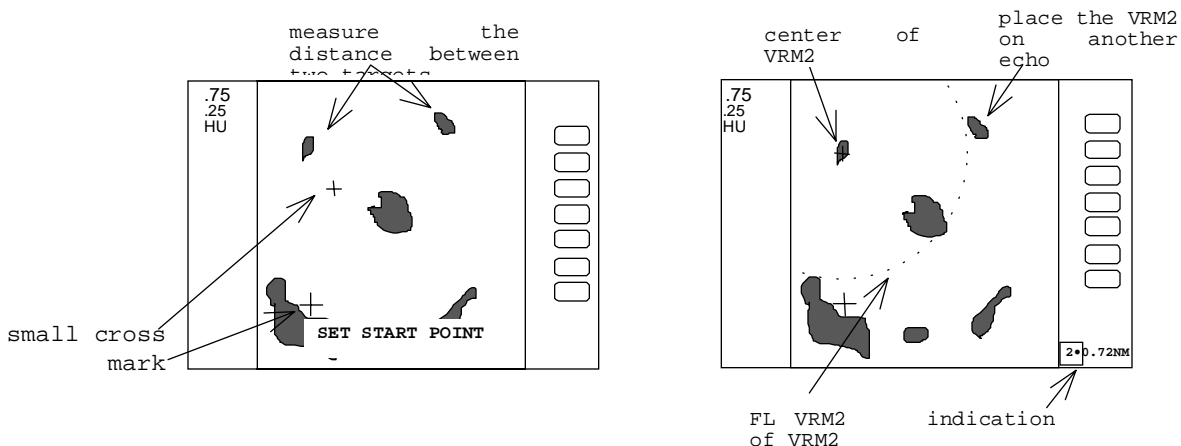

Note: EBL2 and VRM2 are not follow to "ZOOM" and "OFF-C" function.

5.5.1.6 Measuring the angle between two points (FL EBL2)

(a) Preparation for the measurement

- (1) Use the up-down cursor keys to select FL EBL2 from among the pull-down display items, and press the "ENT" key.
- (2) Use the up-down cursor keys to select ON from the ON/OFF display beside the FL EBL2 items, and press the "ENT" key. "SET START POINT" is displayed and a small cross mark appears. (Once this is set, the "ON" state continues unless changes are made.)

→ → → ----- FL EBL2 is turned ON and
 (Select FL EBL2) (Select ON) the small cross mark appears.

(b) Setting a reference point for measurement of the angle.

Use the left-right and up-down cursor keys to place the small cross mark on one of the two echoes whose angle will be measured, and press the "ENT" key.

& → --- Criterion of the reference point is set.
 (Place the cross cursor on an echo)

(c) Measuring

Perform the operations in the above mentioned "Common operation for the MARK menu" and "measuring the distance(EBL2)", and place the EBL2 on another echo.

EBL2 is displayed on the screen based on the placed fixed cross cursor.

" xx. xx°" which is displayed at the lower right will be the angle between the two points.

Note: The displayed EBL angle is relative to heading or true to north, depends on the setting of "EBL BRG" in the "SETUP" menu.

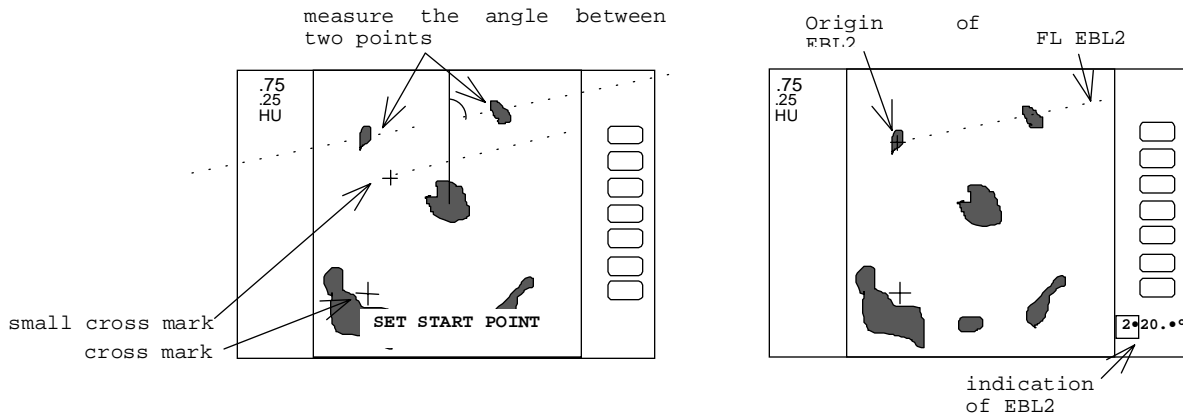

5.5.1.7 Erasing heading marker temporarily (HDG OFF)

- (1) Use the up-down cursor key to select HDG OFF from among the pulled down and displayed items.
- (2) Press the "ENT" key. The heading marker is not displayed as long as you hold it down.

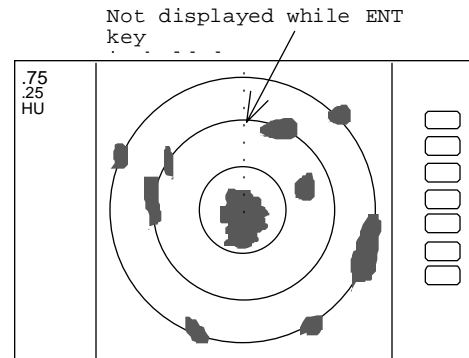

→ ----- The heading marker is not displayed as long as you hold "ENT" key down.
(Select HDG OFF)

5.5.1.8 Using parallel cursors (///CSR)

Normally EBL is used to measure the exact bearing from the position of your ship to a target. However, you can also use parallel cursors.

- (1) Use the up-down cursor key to select ///CSR from among the pull-down and display items, and press the "ENT" key.(ON/OFF display beside the ///CSR item)
- (2) Use the up-down cursor key to select ON .
- (3) Press the "ENT" key. Parallel cursors will appear on the screen. As you move EBL, the parallel cursors also move.

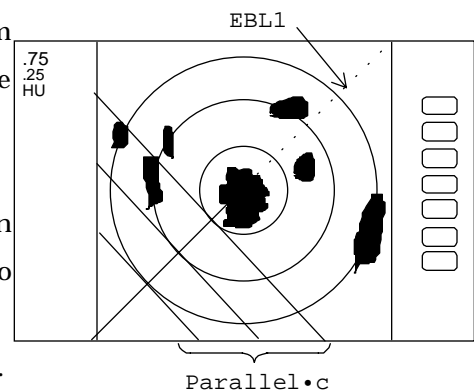

To cancel the ///CSR function, either select OFF in (2).

→ → (Select ON) → -----Parallel cursor appears
 (Select ///CSR) μ> (Select OFF) → -----Parallel cursor non-appears

Note: Interval of ///CSR same as fixed range marker.

///CSR moves with EBL1.

5.5.1.9 Establishment of the indication of the RANGE RINGS (RINGS)

(1) Use the up-down cursor key to select RINGS from among the pull-down and display items, and press the “ENT” key.(ON/OFF displayed beside the RINGS item)

(2) Use the up-down key to select ON or OFF and press the “ENT” key

Select ON Range Rings ON

Select OFF Range rings OFF

→ ---→ (Select ON) → -----Range rings appears
 (Select RINGS) μ> (Select OFF) → -----Range rings non-appears

•Number of range rings and range interval

•Radome antenna (RA40C)

Range	0.125	•0.25	0.5	0.75	1.5	3	6	12	24
Number of Rings	2	2	2	3	6	6	6	6	6
Interval	0.0625	0.125	0.25	0.25	0.25	0.5	1	2	4

Radome antenna (RA41C)

Range	0.125	0.25	0.5	0.75	1.5	3	6	12	24	36
Number of Rings	2	2	2	3	6	6	6	6	6	8
Interval	0.0625	0.125	0.25	0.25	0.25	0.5	1	2	4	4

Open antenna (RA42C)

Range	0.125	0.25	0.5	0.75	1.5	3	6	12	24	48
Number of Rings	2	2	2	3	6	6	6	6	6	8
Interval	0.0625	0.125	0.25	0.25	0.25	0.5	1	2	4	6

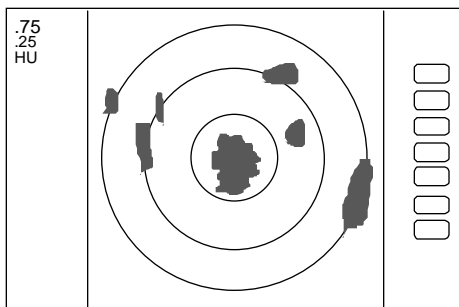

Range rings

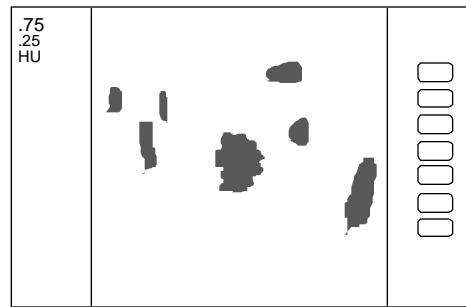

Range rings OFF

5.5.1.10 Variable range function (VAR RNG)

Usually the range changes in steps as 0.5--0.75--1.5--3.0--....., but using this function will enable a consecutive change such as 0.5--0.6--0.7--0.8--..... .

(1) Use the up-down cursor keys to select VAR RNG from among the pulled down and displayed

items, and press the "ENT" key.

- (2) When ON is selected with the up-down cursor key from the ON/OFF display beside the VAR RNG item, and the "ENT" key is pressed, the VAR RNG function becomes valid and **VAR** will be displayed at the upper left of the screen (beside MODE).

Setting procedure

→ → (Select ON) → VAR RNG function is turned ON
(Select VAR RNG) μ> (Select OFF) → VAR RNG function is turned OFF

- (3) The range changes continuously with pressing the up-down cursor while the VAR RNG function is on, and it changes in steps with the "RANGE UP" or "RANGE DOWN" keys.

Method of use

----- Range changes continuously
 & ----- Range changes in step

- (4) To cancel the vari-range function, press a key except "RANGE UP" and "RANGE DOWN" key. When use the function, follow from (1) again.

5.5.1.11 Output the position data of Cursor (TARGET)

Place the cross cursor to the position that is to output position data with up-down and left-right key.

Use the up-down cursor keys to select TARGET from among the pull-down display items, and press the "ENT" key. The L/L data of the position will be output to NMEA port with TLL format.

→ • output the L/L position of the cursor
(Select TARGET)

Note: When activate this function, nothing happens on the screen.

5.5.1.12 Follow the Distance and Bearing marker on the cursor (+MK LINE)

- (1) Use the up-down cursor keys to select +MK LINE from among the pulled down and displayed items, and press the "ENT" key.
- (2) When ON is selected with the up-down cursor key from the ON/OFF display beside the +MK LINE item, and the "ENT" key is pressed, the +MK LINE function becomes valid, and distance/bearing marker will be displayed at the cross cursor.

Setting procedure

→ → (Select ON) → +MK LINE function is turned ON
(Select +MK LINE) μ> (Select OFF) → +MK LINE function is turned OFF

- (3) The distance/bearing marker follows to the cross cursor until +MK LINE function is turned OFF.



CHAPTER 4. FUNCTIONS AND NAMES

Function and name of each part

The RA40C/41C/42C radar consists of a display unit to display video images on a screen and a scanner unit configured with an antenna to radiate radio waves and other components. The display unit has on its front panel eighteen(18) push-switch keys and one cursor key that lets you move a cursor in any desired direction. A combination of these keys allows you to utilize all functions of your radar, providing a comfortable, easy way to operate.

4.1 Key layout

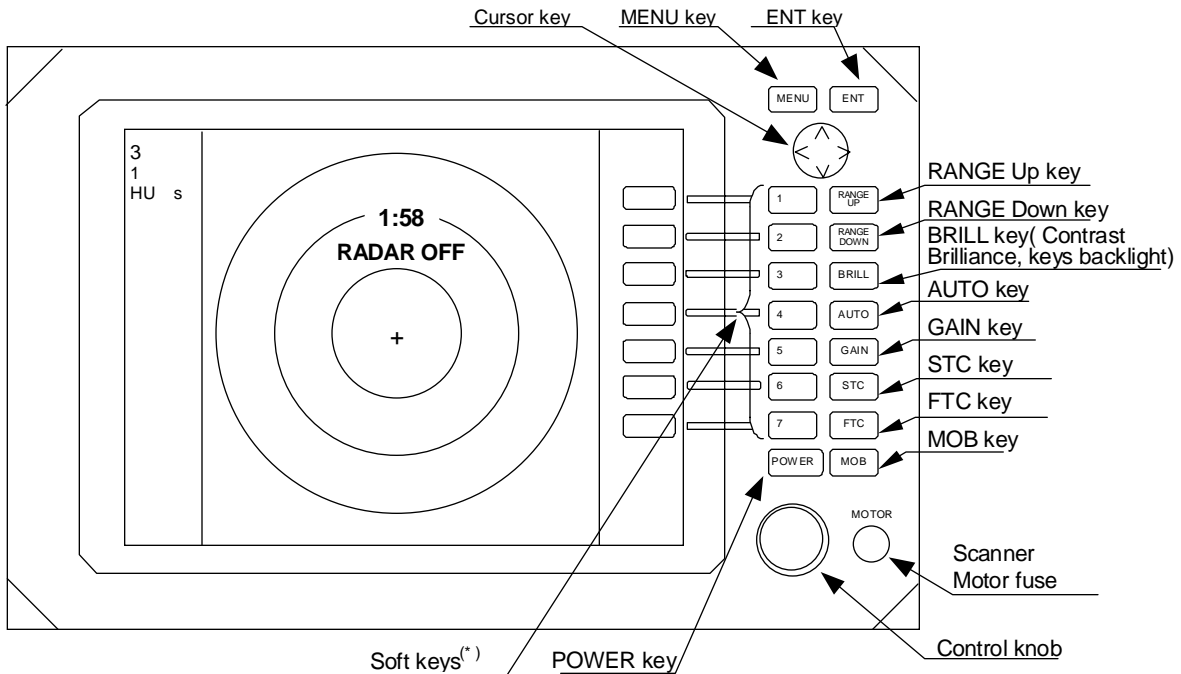

Key No.	SET1	SET2	SET3	SET4
1	EBL1	EBL2	RINGS	PPI
2	VRM1	VRM2	TUNE	PPI/3D
3	VAR RNG	FL EBL2	ST	PPI/PPI
4	TRACK	FL VRM2	ZOOM	PPI/NAV
5	TARGET	GZ	SLEEP	ALL PPI
6	SEL WIN	OFF-C	PICTURE	ALL PPI2
7	NEXT	NEXT	NEXT	NEXT

Tab. 5 Function of soft key (Factory setting)

*Every time Next key is pressed, soft key group switches as follows.

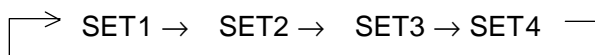

4.2 Rear panel

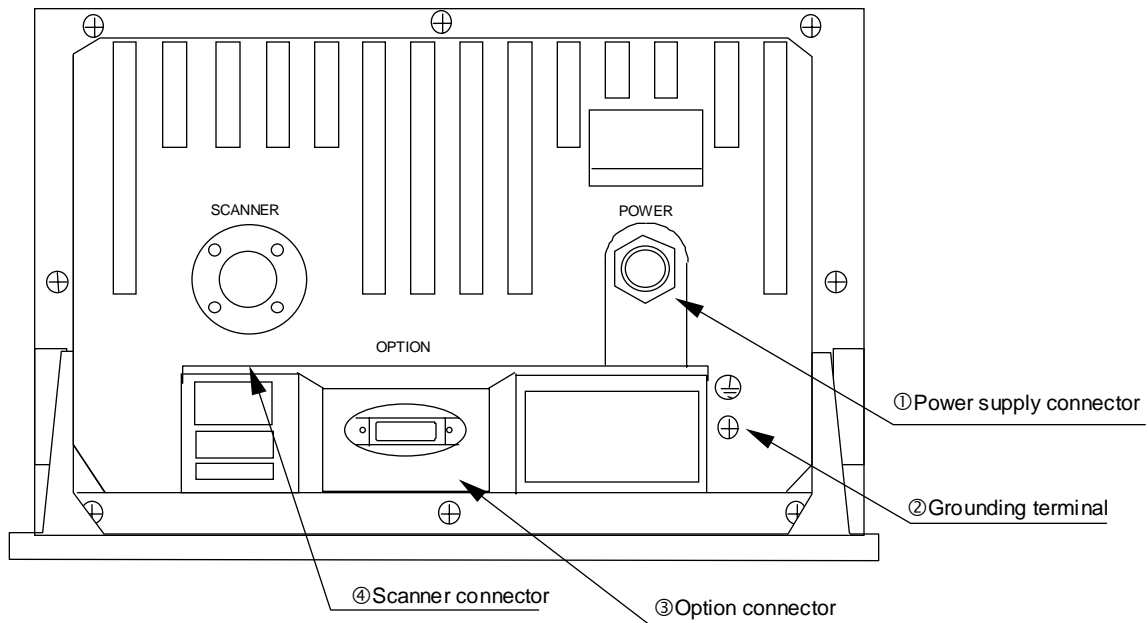

① Power supply connector

Use this connector to plug in the power supply cable. Standard NMEA interface terminal is included in this connector. Refer to Section 3.7 “Connecting Cables” and Section 3.9 “Connecting External Equipment to Display Unit”.

② Grounding terminal

Use this terminal to connect grounding wire. Refer to Section 3.7 (3) “Grounding wire”.

③ Option connector

Use this connector to connect NMEA, an external monitor, external buzzer and GYRO I/F. A dedicated cable or dedicated module box is required to connect these pieces of equipment. Refer to Section 3.9 “Connecting External Equipment to Display Unit”.

④ Scanner connector

Use this connector to plug in the inter-connecting cable to connect the scanner unit. Refer to 3.7 “Connecting cable”.

4.3 Radar screen • Single screen •

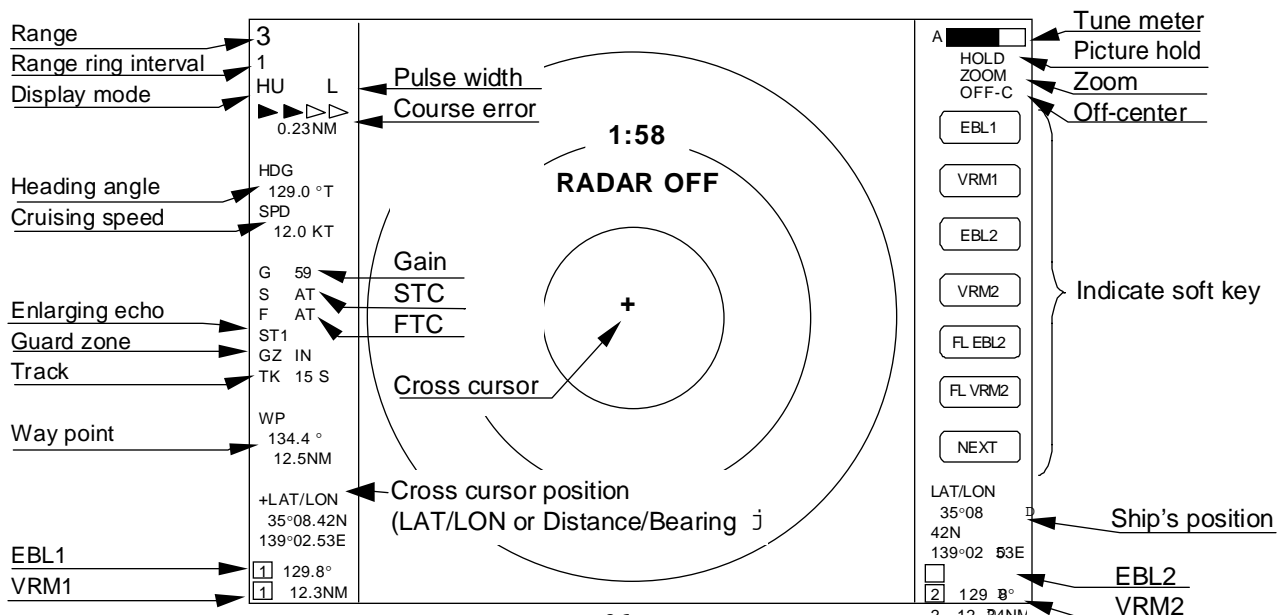

4.4 Radar screen (Dual screen)

ex) PPI/PPI screen

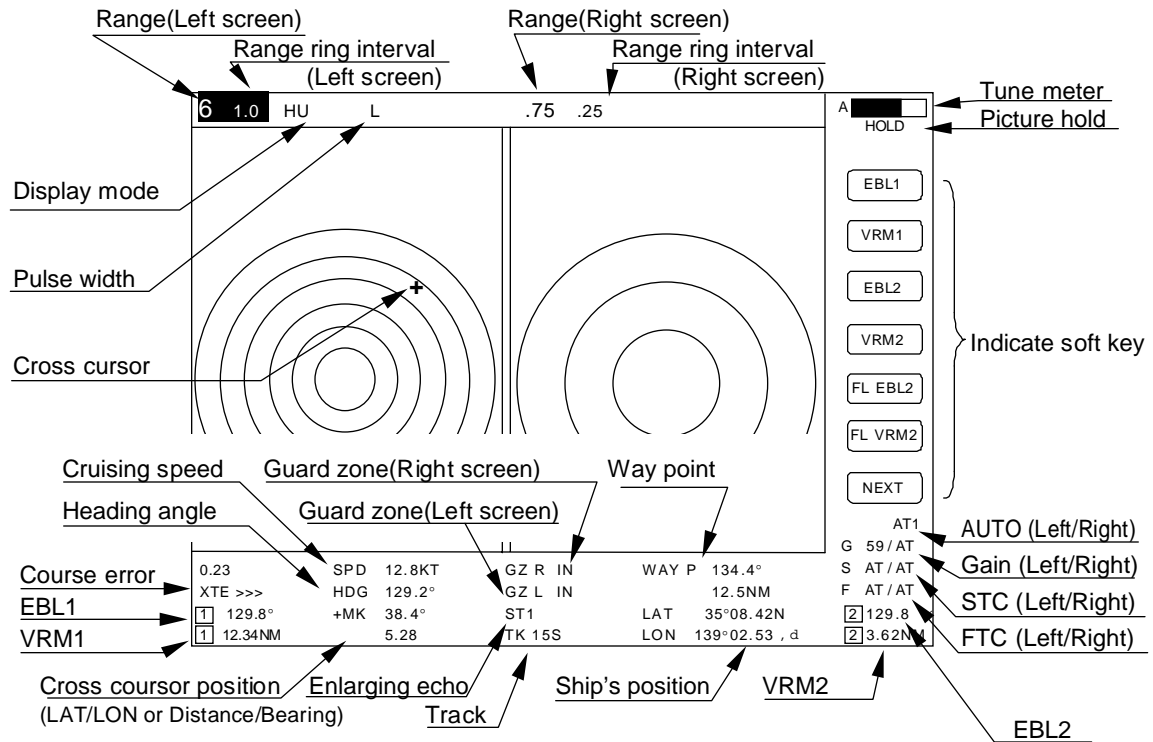

4.5 Radar screen (All PPI screen)

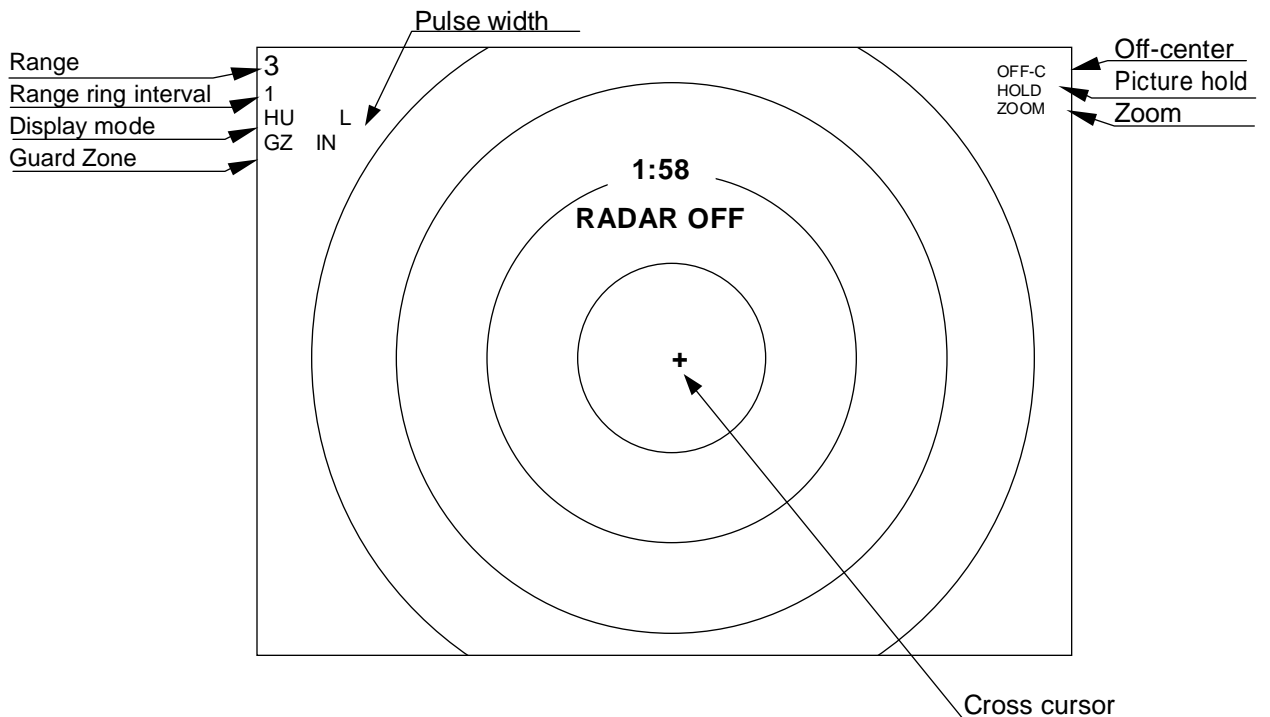

4.6 Radar screen (All PPI /PPI screen)

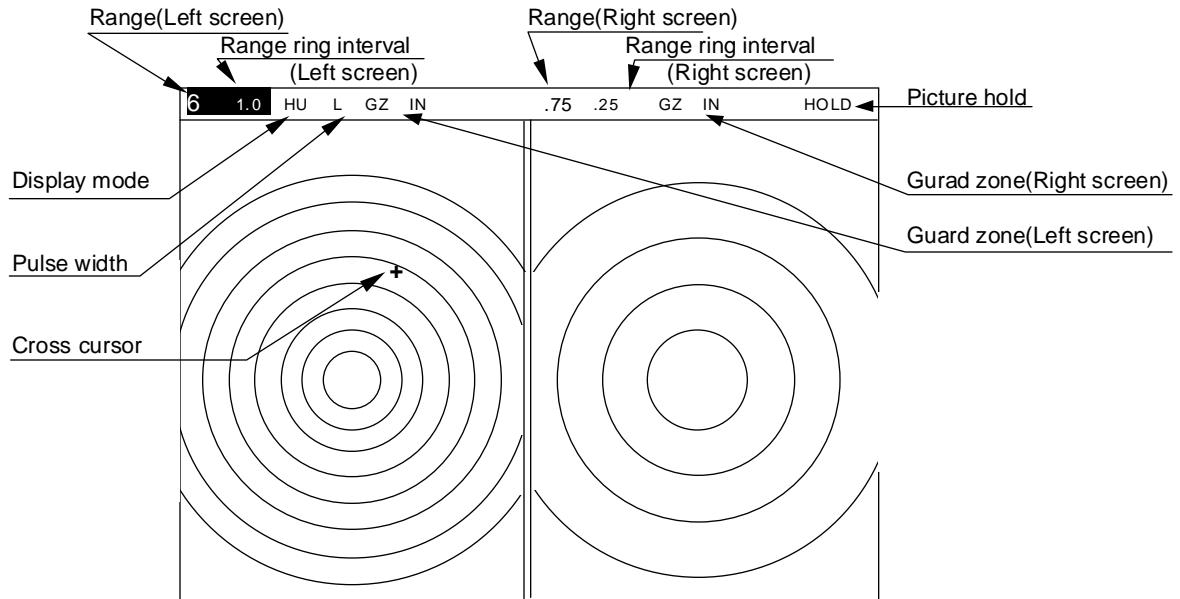

4.7 Navigation screen

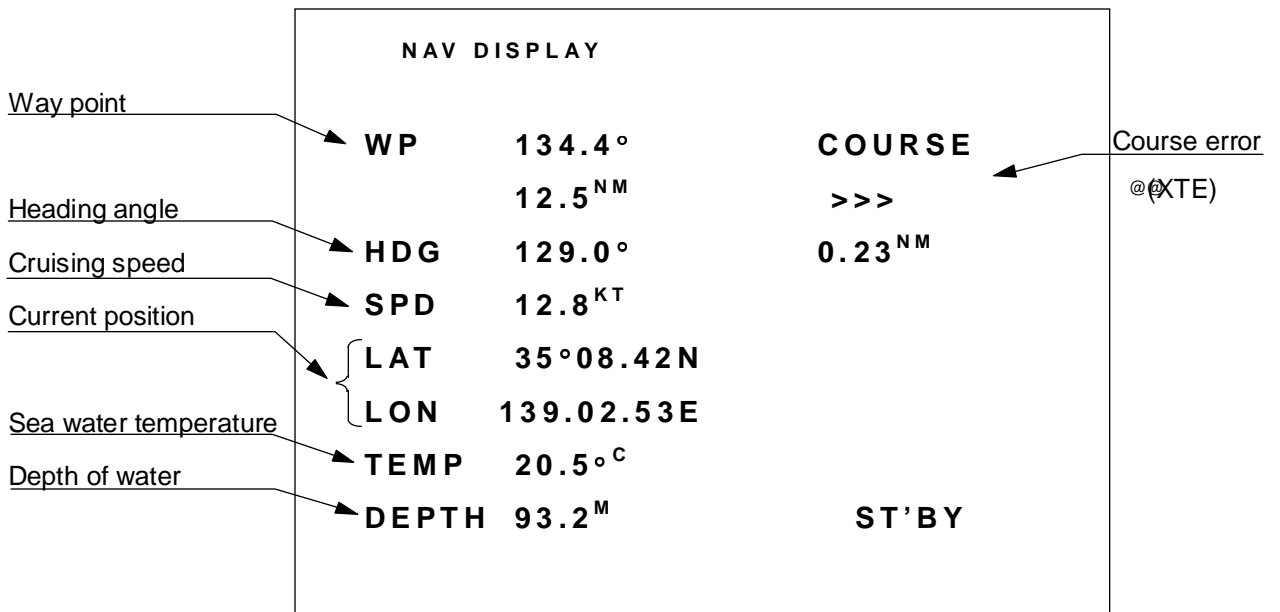

It is necessary that navigation equipment such as a GPS is connected to your radar, this screen displays the position and cruising speed of your ship, seawater temperature, and other navigation information.

Note: Heading angle will be displayed "COG" when Course Over Ground data is used.

Note: Cruising speed will be displayed "SOG" when Speed Over Ground data is used.

Deviation from course	Indication mark
0.00 --	><
0.02 --	> or <
0.04 --	>> or <<
0.08 --	>>> or <<<
0.16 --	>>>> or <<<<

> Indicates starboarding the helm (right)

< Indicates porting the helm (left)

Tab.6 Indication of deviation from course

CHAPTER 6. MAINTENANCE AND INSPECTION

Most of maintenance of this radar should be referred to qualified personnel. If radar has any problem, contact your dealer and tell us that problem.

⚠ WARNING

There are high voltage circuits inside of this radar. Do not attempt to open the rear cover of display unit or disassemble internal parts. When you open the radome, power must be off. Even power switch is OFF, this radar is still supplied power inside.

The following table shows the maintenance by user. Please check periodically.

Tab. 6-1 Maintenance

Inspection Interval	Inspection Item	Method of Inspection and Maintenance
3-6 months	Rust and looseness in scanner unit	Check whether the scanner's fitting bolts are corroded or less.
	Display screen of LCD display	Clean filter and LCD screen surfaces with a soft and wet cloth.
6-12 months	Grease* application to antenna drive gear	Apply an even coating of grease* to the entire surface of the antenna drive gear with a spatula or brush.
	Check for contact of connectors	Check whether connectors are contacted properly. If any connector is improperly contacted or stained, correct it by using a contact restoring chemical agent or by polishing or replace with a new one if necessary.
	Antenna motor brush(RA42C)	Check the length of brushes. If the length is under 6mm, change them to new one.

*: Use grease for plastics for RA40C/41C. If you use other type of grease(not for plastics), it may break antenna

Concerning Consumable

The radar uses consumable as listed below that require periodic replacement.

(1) Magnetron

This part is mounted in the scanner unit. If distant echo images have become less visible, the magnetron probably may have degraded. In such a case, replace it. Consult your distributor for replacement of this part.

Period of the replacement : 3000hour(typ.) (500hour guarantee)

(2) LCD back-light

This part is mounted in the display unit. If the display screen is extremely dark and its illumination cannot be corrected by adjusting brightness, the LCD back-light may be faulty or may have burnt out. In such a case, replace it. Consult your distributor for replacement of this part.

Period of the replacement : 15000hour(typ.) (1000hour at 0•)

(3) Fuse

The fuse is built in the power supply cable. If the fuse appears to be blown, check the fuse. If blown, replace it following the procedure shown in Fig.6-2.

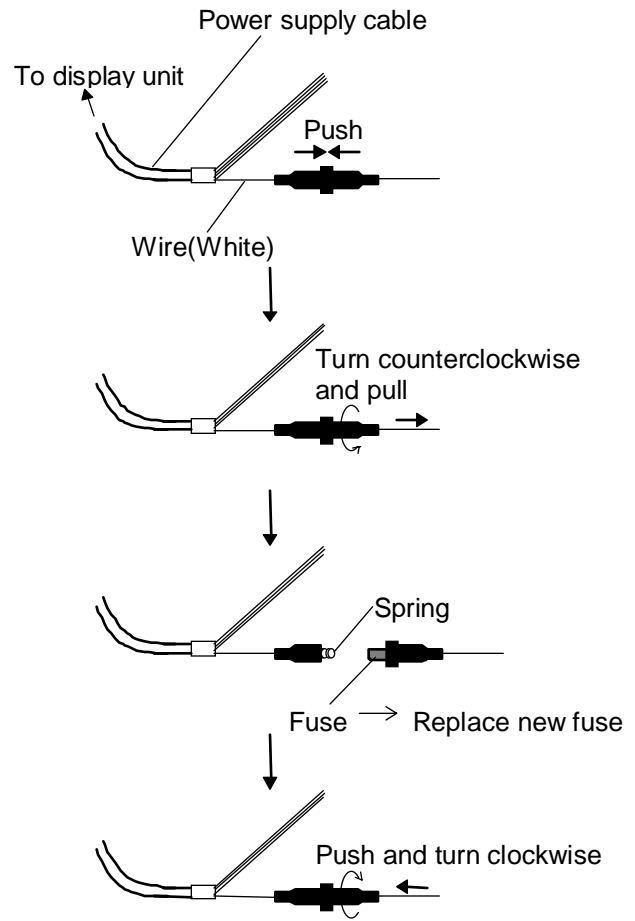

Fig. 6-2 Method for replacing fuse

Note: Before maintenance of scanner, you can hang a radome(upper) using cord through hole as follows.

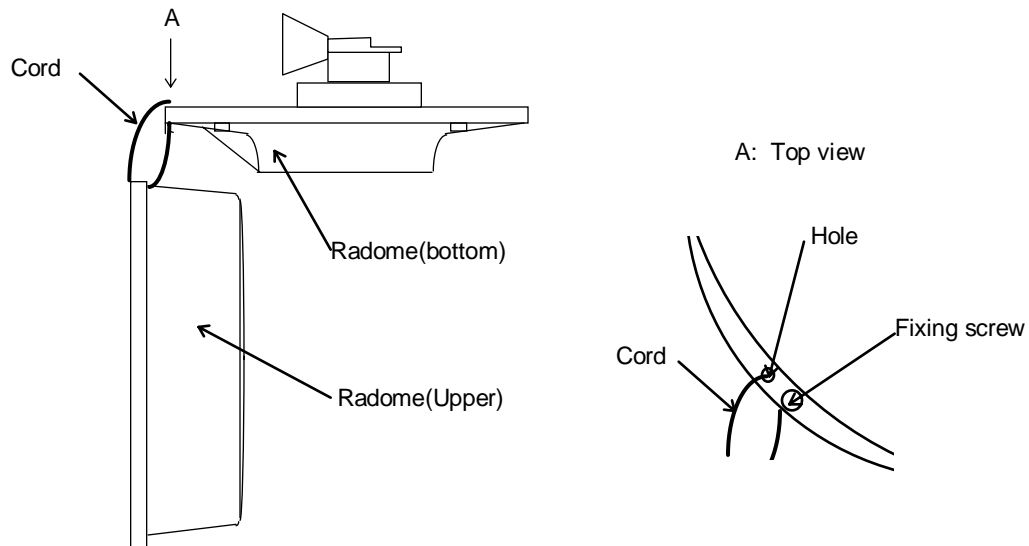

Fig. 6-3 Method for replacing fuse

CHAPTER 6. MAINTENANCE AND INSPECTION

Most of maintenance of this radar should be referred to qualified personnel. If radar has any problem, contact your dealer and tell us that problem.

⚠ WARNING

There are high voltage circuits inside of this radar. Do not attempt to open the rear cover of display unit or disassemble internal parts. When you open the radome, power must be off. Even power switch is OFF, this radar is still supplied power inside.

The following table shows the maintenance by user. Please check periodically.

Tab. 6-1 Maintenance

Inspection Interval	Inspection Item	Method of Inspection and Maintenance
3-6 months	Rust and looseness in scanner unit	Check whether the scanner's fitting bolts are corroded or less.
	Display screen of LCD display	Clean filter and LCD screen surfaces with a soft and wet cloth.
6-12 months	Grease* application to antenna drive gear	Apply an even coating of grease* to the entire surface of the antenna drive gear with a spatula or brush.
	Check for contact of connectors	Check whether connectors are contacted properly. If any connector is improperly contacted or stained, correct it by using a contact restoring chemical agent or by polishing or replace with a new one if necessary.
	Antenna motor brush(RA42C)	Check the length of brushes. If the length is under 6mm, change them to new one.

*: Use grease for plastics for RA40C/41C. If you use other type of grease(not for plastics), it may break antenna

Concerning Consumable

The radar uses consumable as listed below that require periodic replacement.

(1) Magnetron

This part is mounted in the scanner unit. If distant echo images have become less visible, the magnetron probably may have degraded. In such a case, replace it. Consult your distributor for replacement of this part.

Period of the replacement : 3000hour(typ.) (500hour guarantee)

(2) LCD back-light

This part is mounted in the display unit. If the display screen is extremely dark and its illumination cannot be corrected by adjusting brightness, the LCD back-light may be faulty or may have burnt out. In such a case, replace it. Consult your distributor for replacement of this part.

Period of the replacement : 15000hour(typ.) (1000hour at 0•)

(3) Fuse

The fuse is built in the power supply cable. If the fuse appears to be blown, check the fuse. If blown, replace it following the procedure shown in Fig.6-2.

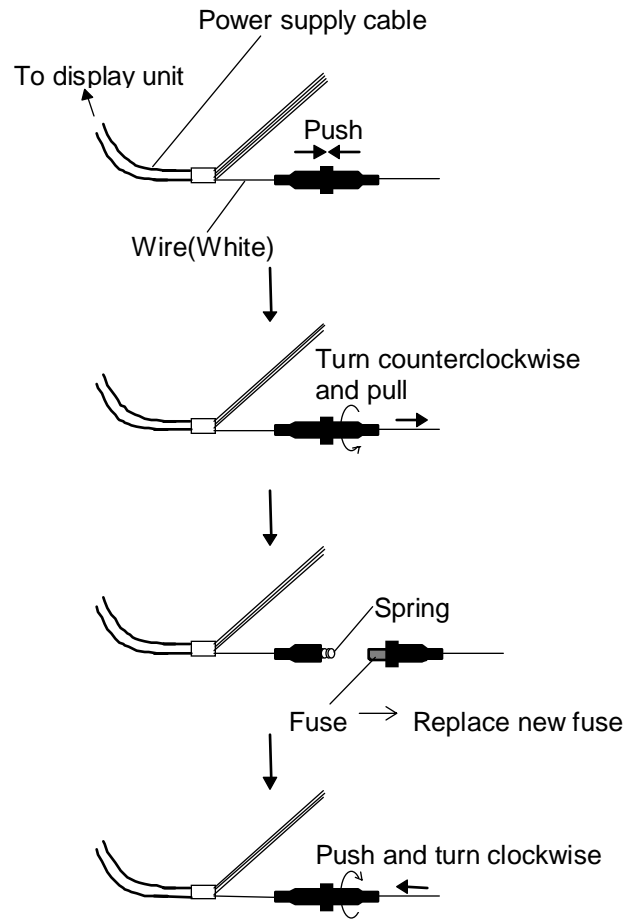

Fig. 6-2 Method for replacing fuse

Note: Before maintenance of scanner, you can hang a radome(upper) using cord through hole as follows.

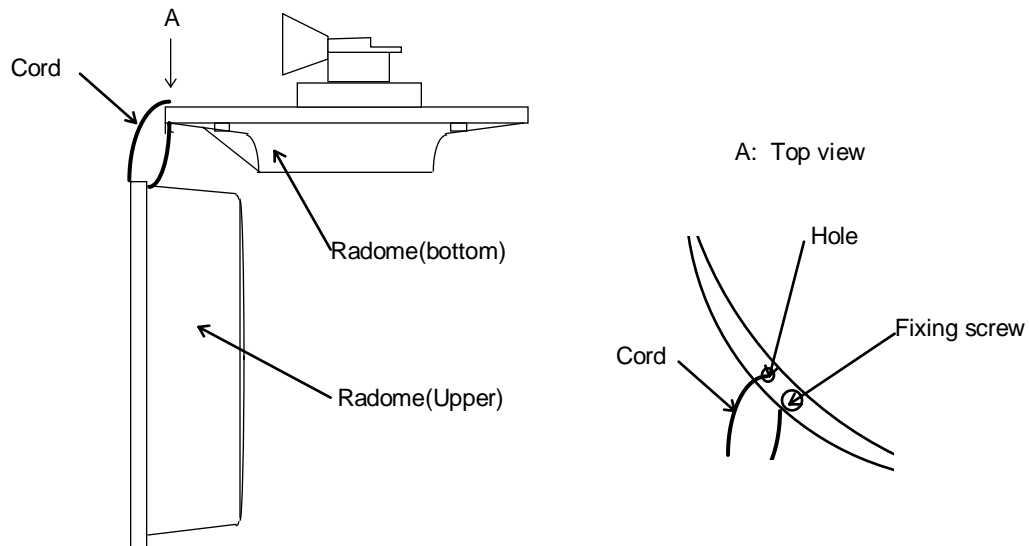

Fig. 6-3 Method for replacing fuse

CHAPTER 7. TROUBLESHOOTING

This chapter explains how to identify trouble locations when the radar is found faulty and how to request repair.

If happens any disorder, keep pressing POWER key for 3 sec. to power off. Then wait over 10 sec., when you power on again.

If you find the radar is faulty, check it the following procedure described below. If you find as a result of inspection that the fault cannot be repaired on board, contact your distributor for repair.

For faster service, please let us know about followings when you request repair:

- (1) Ship's name, place of anchorage, allowable repair period or time
- (2) Radar type (This radar is RA40C, RA41C or RA42C.)
- (3) Manufacturing number (indicated on the back of the display unit)
- (4) Fault symptoms and inspection results

WARNING

There are high voltage circuits inside of this radar. Do not attempt to open the rear cover of display unit or disassemble internal parts. When you open the radome for installation, power must be off. Even power switch is OFF, this radar is still supplied power inside.

This chapter explains how to identify trouble locations when the radar is found faulty and how to request repair.

7.1 Fault Diagnosis by Self-check_____

The radar incorporates a failure diagnostic function (called "self-check") to diagnose faults by the equipment itself.

Refer to "5.5.4.4 Fault Diagnosis by Self Check (SYSTEM CHECK)" and check whether there is any fault in your radar.

7.2 Inspecting Each Part_____

When you have finished self-check, inspect each part of the radar according to Tab.7-1.

Tab. 7-1 Troubleshooting

Symptom	Cause	Corrective action
(1) Radar cannot be powered on.	Power cable is disconnected.	Connect power cable correctly.
	Power supply voltage is off specified value	Use Specified power supply. (See Section 3.2)
	Fuse in power cable is blown.	Replace fuse. (See Chapter 6)
(2) Nothing is displayed although radar is powered on.	Brightness or contrast are improperly adjustment.	Use BRIL key to adjust. (See Section 5.3.)
	LCD is faulty.	Contact your dealer.
(3) Screen is dark.	Brightness is improperly adjusted.	Use BRIL key to adjust. (See Section 5.3.)
	Backlight is faulty.	Contact your dealer.
(4) Video does not appear although characters are displayed.	Interconnecting cable is out of place.	Connect interconnecting cable correctly.
(5) Echo image on screen differs from actual image.	Ship's heading is incorrectly set.	Set ship's heading correctly. (See Section 5.5.4.5.4)
	Timing adjustment is incorrectly set.	Set timing adjustment correctly. (See Section 5.5.4.5.4)
(6) Echo images are blurred.	GAIN, STC, or FTC is improperly set.	Adjust. (See Section 5.3.6 to 5.3.8.)
	Magnetron has degraded.	Contact your dealer.
(7) Too much noise.	Radar is not tuned correctly	Adjust TUNE. (See Section 5.5.3.4)
	Radar is not grounded to earth.	Connect grounding wire. (See Section 3.4 to 3.6.)
(8) Not responded when key is pressed.	Panel keys are not contacting.	Contact your dealer.
	Power supply circuit is faulty.	Contact your dealer.

CHAPTER 8. PRODUCT SPECIFICATIONS

8.1 General

Type:	RA40C, RA41C and RA42C	
Power supply voltage and power consumption		
••••Power supply voltage:	24Vdc (nominal) (10.2 to 41.6 Vdc)	
••••Power consumption:	55 W or less (RA40C/41C) 70 W or less (RA42C)	
Distance range:	0.125 to 24 NM, 9 ranges (RA40C) 0.125 to 36 NM, 10 ranges (RA41C) 0.125 to 48 NM, 10 ranges (RA42C) (Continual variable range also possible)	
Distance resolution:	Within 30 m (RA40C) Within 25 m (RA41C/42C)	
Distance accuracy: maximum	Better than 0.9% of range of the scale in use, or whichever is the greater	
8m,		
Minimum detecting distance:	Within 30 m (RA40C) Within 25 m (RA41C/42C)	
Bearing resolution:	Within 7.5° (RA40C) Within 4.5° (RA41C) Within 3.0° (RA42C)	
Bearing accuracy:	1° or less	
Warm-up time:	2 minutes	
Environment conditions		
•••Ambient temperature range	(S/U):	-25 to 55 °C
	(D/U):	0 to 55 °C
Humidity:	93% RH at +40 °C	
Vibration:	(S/U): 3 mm(300 to 500 rpm) 1.2 mm(500 to 1500 rpm) 0.3 mm(1500 to 3000 rpm) 14.7m/s ² (1.5G) Resonance	
test	(D/U):	3 mm(300 to 500 rpm) 0.75 mm(500 to 1500 rpm)
		0.2 mm(1500 to 3000 rpm)

rpm)

Wind resistance: 100 knots (max.)

Waterproof standard: (D/U): IPX-5
(S/U): IPX-6

Interconnecting cable: 30 m in max. (RA40C)
100 m in max. (RA41C/42C)

Noise: (D/U): 65 dB or less
(S/U): 65 dB or less (RA40C/41C)
(S/U): 70 dB or less (RA42C)

8.2 Scanner Unit

Type:	RB714A (RA40C) RB715A (RA41C) RB716A (RA42C)
Antenna type:	Parabolic (RA40C) Slotted-array (RA41C/42C)
Antenna characteristics	
Beam width (horizontal):	6.0° ± 1.0° (RA40C) 3.9° (RA41C) 2.5° ± 0.3° (RA42C with 3ft antenna) 1.8° ± 0.2° (RA42C with 4ft antenna)
Beam width (vertical):	25° (typ.) (RA40C/41C) 22° (typ.) (RA42C with 3/4ft antenna)

Pulse width and peak power output:•

RA40C		RA41C/42C	
Pulse width (μsec)	Peak Power (kW)	Pulse width (μsec)	Peak Power (kW)
0.12 ± 0.02	1.5 (±50%)	0.08	4 (-50% to +20%)
0.3 ± 0.05	2.0 (±50%)	0.25	4 (-50% to +20%)
0.8 ± 0.1	2.0 (±50%)	0.8	4 (-50% to +20%)

Radio wave type and frequency:	PON, 9445 ± 30 MHz (RA40C) PON, 9410 ± 30 MHz (RA41C/42C)
Antenna revolution:	24 rpm ± 20%
Transmit/receive switching:	Magic T and limiter type (RA40C) Circulator and limiter type (RA41C/42C)
Intermediate frequency:	60 MHz (logarithmic amplifier)
Noise figure:	6.5 dB or less

8.3 Display Unit

Type:	RF719A
Indication system:	PPI, PPI+semi-3D, Split radar range
Indicator:	10-inch color LCD(TFT) 640 x 480 dots Four(4) levels

Cursor Control:	Analog cursor key and rotary encoder
VRM:	2 lines (One line can be offset.) Unit of distance can be selected from NM, KM, and SM.
EBL:	2 lines (One line can be offset.)
Display modes:	HU, HS, NU, CU, and TM
Off-center:	Can be 100% off-centered over the full range.
Guard zone:	Can be set at any desired distance and angle in any desired width. IN and OUT modes are available.
Stretch:	2 modes
Echo track:	15, 30 sec, 1, 3, 6 min. and continuous.
Other functions:	Interference rejection, Zoom, Sleep mode, Hold mode, Course error display, Parallel cursors, Stern marker, and Navigation data display mode
Panel brightness:	4 levels
Language support:	Chinese, Danish, English, French, German, Greek, Italian, Japanese, Korean, Norwegian, Portuguese, Russian, Spanish, Swedish, and Turkish

8.4 External Interface

NMEA0183:	2 channels (One standard channel; Optional cable is required for 2nd-channel connections)
L / L	GGA, GLL, RMA, RMC
Heading	HDT, HDG, HDM, HSC, VHW, VTG
Speed	VHW, VTG, RMA, RMC
Way point	RMB, BEC, BWC, BWR, BER, BPI
Depth	DBT, DPT
Course error	RMB, XTE

Others (using optional cable):

External buzzer control output, Auxiliary indicator connecting signal output and input, Bow direction signal input(SIN/COS signals), and compass interface (10/12 bits serial)

8.5 Standard set

Display unit	1
Scanner unit	1
Display cover	1
Fuse	1 set
Interconnecting cable	1 (10m)
Power supply cable	1 (2m)
M10 hexagonal bolt	4 sets (for RA40C/41C)
M12 hexagonal bolt	4 sets (for RA42C)

8.6 Options

Interconnecting cable (15, 20, and 30 m for RA40C)	
Interconnecting cable (15, 20, and 25 m for RA41C/42C)	
Flush-mount installation kit	
Junction box for external connection (with cable 1.5m)	
Option connector kit	249J153058

8.7 External dimensions and weight

See APPENDIX

8.8 External Connection and function

X1	Connector for Option		
pin No.	Name	function	
1	NMEA2-A	NMEA ch2 data input(A)	
19	NMEA2-B	NMEA ch2 data input(B)	
2	GND		
20	EXBUZ+	Output for External Buzzer	
3	EXBUZ-	Output for External Buzzer	
		controlled ship's power output	
21	VIDEO_IN	Video input for Monitor operation	
		0 to -1V negative video, Zi = 50ohm	
4	VIDEO_OUT	Video output for External Monitor	
		0 to -1V negative video, Zo = 50ohm	
22	GND		
5	TRIG_IN	Trigger signal input for Monitor operation	
		0 to 5V positive pulse, rising edge	
23	TRIG_OUT	Trigger output for External Monitor	
		0 to 5V positive pulse, rising edge	
6	SHF_IN	Heading signal input for Monitor operation	
		0 to 5V negative pulse, falling edge	
24	SHF_OUT	Heading signal output for External Monitor	
		0 to 5V negative pulse, falling edge	
7	AZI_IN	Bearing Pulse input for Monitor operation	
		0 to 5V positive pulse, rising edge	
25	AZI_OUT	Bearing Pulse output for External Monitor	

		0 to 5V positive pulse, rising edge
8	GND	
26	GYRCK+	Gyro Interface clock(+) input
9	GYRCK-	Gyro Interface clock(-) input
		apply 5V pulse between (+) and (-), isolated
27	GYRDT+	Gyro Interface data(+) input
10	GYRDT-	Gyro Interface data(-) input
		apply 5V pulse between (+) and (-), isolated
28	GND	
11	MARK_I	External Marker signal input, ex) Radar Buoy negative video, 0 to -1V Zi = 50ohm
29	+12V	External interface power, 100mA max.
12	SIN	Compass Interface for SIN/COS type
30	COS	Compass Interface for SIN/COS type
13	REF	Compass Interface for SIN/COS type
		SIN/COS signal: SIN = REF+/-1V, COS = REF+/-1V
31	--	not used
14	GND	
32	NMEA_OUT	NMEA data output, ex) MOB data, TARGET data