

kogan

1200W Deluxe Stand Mixer

**KA1KSTMXSLA
KA1KSTMXRDA**

USER MANUAL



General Safety Instructions

Read the operating instructions carefully before putting the appliance into operation and keep a copy of the instructions handy for future reference. If you give this device to other people, please also pass on these operating instructions.

- The appliance is designed **exclusively** for private use. This appliance is not fit for commercial use. **Do not** use it outdoors. Keep it away from sources of heat, direct sunlight, humidity (never dip it into any liquid) and sharp edges. Do not use the appliance with wet hands. If the appliance is humid or wet, unplug it immediately.
- When cleaning or putting it away, switch off the appliance and pull the plug out from the socket (pull on the plug, not the cable). If the appliance is not being used, remove any attached accessories.
- **Do not** operate the machine without supervision. If you should leave the working space, always switch the machine off or remove the plug from the socket (pull the plug itself, not the lead).
- Check the appliance and the cable for damage on a regular basis. **Do not** use the appliance if it is damaged.
- **Do not** try to repair the appliance on your own. Always contact the Kogan customer service team. To avoid exposure to danger, always have a faulty cable replaced only by a Kogan technician.
- Pay careful attention to the “Special Safety Instructions” section.

Children and Frail Individuals

- In order to ensure children’s safety, please keep all packaging (plastic bags, boxes, polystyrene etc..) out of their reach.
- In order to protect children or frail individuals from hazards, please ensure that this device is only ever used under supervision. **This device is not a toy.** Do not allow small children to play with it.

Special Safety Instructions

- **Do not** interfere with any safety switches.
- **Do not** insert anything into the rotating hooks while the machine is working.
- Place the machine on a smooth, flat and stable working surface.
- **Do not** insert the mains plug of the machine into a power socket without

having first installed all of the necessary accessories.

- Remove and discard all packaging materials and stickers before use.
- This appliance is for household use only. Do not use in moving vehicles or on boats. Do not use outdoors, and do not use for any purposes other than its intended use.
- **Unplug** the mixer when the work is done.
- **Never** raise the arm until the motor has completely stopped working and all accessories have stopped moving completely.
- **Never** immerse the motor into water for cleaning.
- **Keep children away when operating.** Children should never be allowed to use this product.
- This appliance can be used by persons with reduced physical, sensory or mental capabilities or lack of experience and knowledge if they have been given instruction concerning use of the appliance in a safe way and if they understand the hazards involved.
- **Do not** use the appliance near the edge of a countertop or table. Ensure the surface is level, clean and free of water and other substances. Please be aware that vibration during use may cause the appliance to move in unexpected ways.
- **Do not** use the appliance on (or close to) a hot gas or electric burner, or where it could touch a heated oven or surface.
- **Do not** allow the cord to hang over the edge of a countertop or to become knotted.
- To avoid electric shock, **do not** immerse the cord, plug or motor base in water or any other liquids.
- Installation of a residual current device (such as a standard safety switch on your wall socket) is recommended to provide additional safety protection when using appliances. It is advisable that a safety switch (with a rated residual operating current not more than 30mA) be installed in the electrical circuit supplying the appliance.
- In order to avoid the possible hazard of the unit starting by itself due to inadvertent resetting of the overload protector on the motor, do not attach an external switching device (such as a timer) or connect the appliance to a circuit that can switch the unit on and off.

- **Do not** operate the appliance with a damaged cord or plug, after the appliance malfunctions, or if the appliance is dropped or damaged in any way. Stop use immediately and contact the Kogan customer support team.
- Only use the bowl, accessories and attachments that are supplied. The use of accessories not supplied by Kogan.com may result in fire, electric shock, damage to the unit or personal injury.
- **Always** ensure the appliance is fully assembled securely before operating.
- If the motor appears to be straining under a heavy load, do not operate continuously for longer than 10 seconds at a time. Allow the motor to rest for 1 minute between uses on heavy loads.
- **Never** leave the appliance unattended while in use.
- Keep fingers, hands, hair and clothing away from the accessories during use. Always unplug the appliance and unplug at the wall before raising the arm.
- **Be careful** when handling or cleaning the accessories as they can be sharp.
- **Do not** raise the arm while the blender is operating.
- **Never** attempt to use appliance with damaged accessories or with any foreign utensils inside the bowl.
- **Never** mix boiling hot liquids. Allow the temperature to drop before putting into the lowering the arm and turning unit on.
- **Do not** expose the bowl and accessories to temperature extremes. For example do not lower extremely cold beaters into extremely hot mixture.
- Before moving the mixer, cleaning or putting it away, always turn the blender off and unplug it at the wall.
- **Never** run the mixer while empty.
- **Do not** overfill.
- **DANGER OF OVERLOADING!** Please use the device either as a mincer or a mixer, but never both functions at the same time.

Component Overview

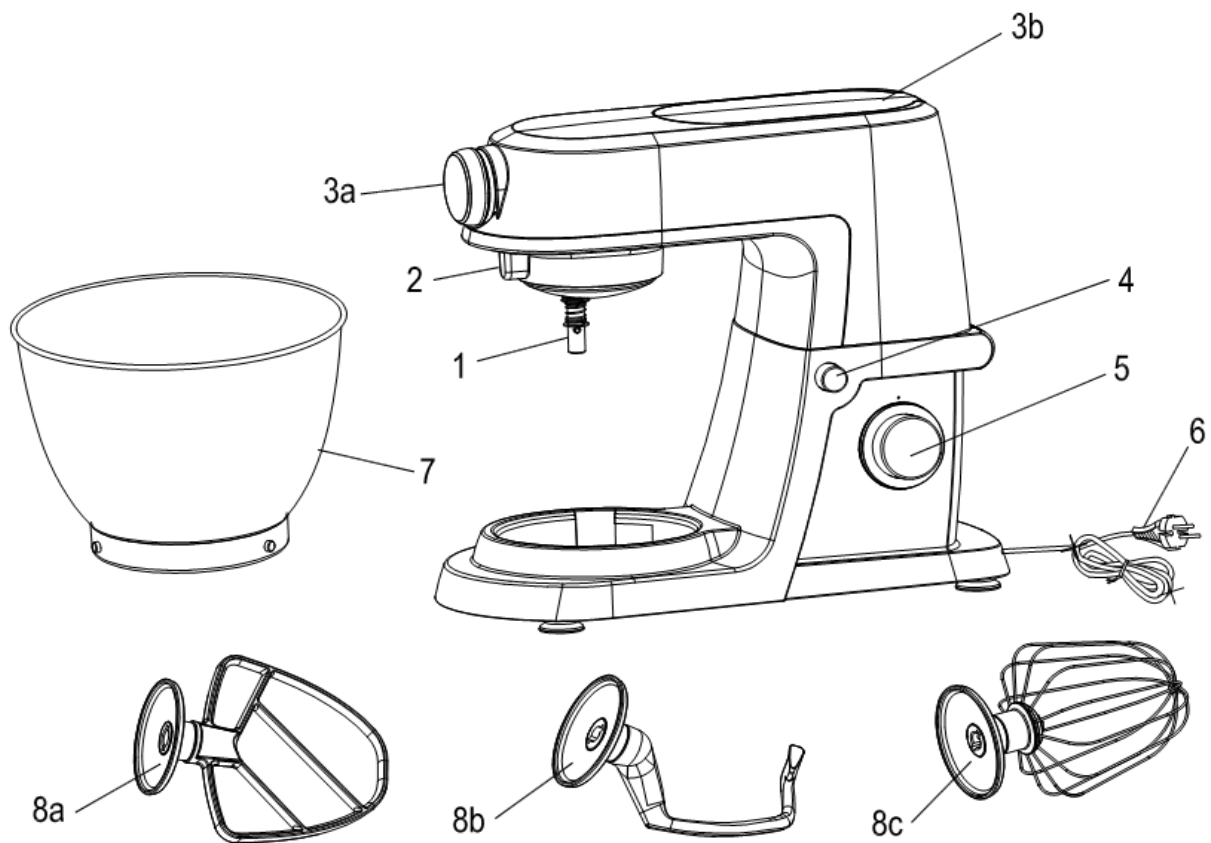

Main Components and Standard Accessories

1	Drive Shaft	6	Power Cord
2	Cap of arm	7	Mixing Bowl
3a	Front Protector	8a	Stirrer
3b	Jar Protector	8b	Kneading Hook
4	Arm raising/lowering lever	8c	Whisk
5	Pulse operator and lever regulator		

Using the Mixing Bowl

WARNING: AVOID INJURIES BY ENSURING THE UNIT IS UNPLUGGED FROM THE WALL POWER SOCKET BEFORE SETTING MIXER UP!

1. Place the mixing bowl into its holding device, then turn the bowl in the direction of the LOCK until it locks into place.
2. In order to lift the arm, press the lever (4) downwards in the direction of the arrow. The arm will now move upwards.
3. Mount the required utensil by inserting the top into the drive shaft, then

- lock the cotter pin into the shaft by turning utensil to the right.
4. Fill the bowl with your ingredients. (Do not overfill the machine - the maximum quantity of ingredients is 1.5kg)
 5. Lower the arm using the lever (4).
 6. Insert the mains plug into the wall power socket.
 7. Switch the machine on, using the level regulator to a speed between 1 and 6 (depending on the mixture).
 8. For pulse operations (kneading at short intervals), turn the switch to the "PULSE" position. The switch has to be held in this position according to the desired mixing duration length. When the switch is released, it will return automatically to the "0" position.

Levels and Hook Usage for Mixtures of less than 1.5kg

Levels	Use	Type of Mixture
1 - 2	Kneading Hook	Heavy mixtures (bread or short pastry)
3 - 4	Stirrer	Medium-heavy mixtures (crepes or sponge)
5 - 6	Whisk	Light mixtures (cream, egg white, blancmange)
Pulse	Whisk	Intervals (mixing under sponge, egg white etc...)

Note: with heavy mixtures, do not operate the machine for more than ten minutes. Allow it to cool down for a further ten minutes.

Note: use the splash guard to protect against liquid mixture spillage.

9. After kneading/stirring, turn the switch (5) back to the "0" position as soon as the mixture has formed a ball. **Remove the mains plug from the wall socket.**
10. Press the lever (4) downwards and the arm will be raised.
11. The mixture can now be released with the help of a spatula from the mixing bowl.
12. The mixing bowl can now be removed by turning it to the left.
13. Clean the parts as described under the "Cleaning" section.

WARNING: BE SURE TO UNPLUG THE MAINS PLUG FROM THE WALL BEFORE RAISING THE ARM AND REMOVING THE BOWL.

Cleaning

- **Remove the mains plug from the power socket before cleaning.**
 - **Never** immerse the unit housing with the motor in water!
 - **Do not** use any sharp objects or abrasive detergents.
 - Only a damp cloth should be used to clean the outside of the housing.
 - All components (mixing bowls, hooks etc...) that come into contact with food can be cleaned with soapy water.
- Note: No components are suitable for dishwasher cleaning.