

kogan

**12,000/14,000 BTU
Portable Air Conditioner**

**KAPORAIR12GA
KAPORAIR14GA**

USER MANUAL



Thank you for selecting this high quality portable air-conditioner. Before use, read all instructions carefully. If you have any further questions, please contact the Kogan.com customer support team.

Table of Contents

Instruction Guide.....	2
Precautions.....	2
Important Safety Tips.....	2
Usage Notes.....	2
Product Layout.....	3
Control Panel & Remote Control.....	3
Product Usage.....	4
Placement.....	4
Installation.....	4
Incorrect Installation.....	5
Remote Control.....	5
Unit Operation.....	5
Cleaning and Maintenance.....	6
Drainage Method.....	6
Case Cleaning.....	7
Filter Screen.....	7
Seasonal Maintenance.....	7
Common Failures & Diagnostics.....	8
Intelligent Failure Detection.....	8
Breakdown Maintenance.....	8
Specifications.....	8

Instruction Guide

Precautions

- This air-conditioner is intended for household use only. Not suitable for use in commercial or industrial surroundings.
- This air-conditioner should only be used indoors in a dry environment. Do not use air-conditioner outdoors under any circumstances.
- Do not place or store objects around the air-conditioner. Air must be able to flow freely around the unit.
- Do not place anything on top of the air-conditioner.
- Do not operate the air-conditioner with wet hands or in a damp environment.
- To clean the air-conditioner, wipe it with a soft cloth. Do not use wax, thinners or any other cleaning agents.
- Clean the filter regularly. Once every two weeks is recommended.
- Do not drink the water from the condenser that the air-conditioner discharges.
- If you will not be using the air-conditioner for an extended period of time, unplug the power cord.
- There are no user-serviceable parts inside the air-conditioner. All maintenance must be done by a Kogan.com technician or a suitably qualified repair service.

Important Safety Tips

- Do not use damaged power cords or plugs. Do not plug the air-conditioner into a loose power outlet.
- Before use, ensure that the voltage supply matches the requirements of the air-conditioner.
- Do not attempt to modify or extend the power cord.
- Do not handle the plug with wet hands. This may lead to electric shock.
- When unplugging the power cord, hold the plug itself and remove. Never pull on the cord itself to unplug an electrical device.
- Do not operate the unit by turning the power supply on or off at the wall, nor by simply plugging and unplugging the power cord.
- Turn the air-conditioner off before unplugging the unit.
- Do not share a single power outlet with multiple high demand electrical appliances.
- Keep air-conditioner away from heat sources and keep it out of direct sunlight.
- If the air-conditioner starts to emit a strange noise, odour or smoke, switch the unit off immediately and disconnect the plug from the power socket. Contact the Kogan.com customer support team for further information.
- Do not place heavy objects on the power cord.
- Do not place fingers or objects into the air outlet.
- Do not allow water to enter the air-conditioner. If water does get into the unit, turn it off and disconnect the plug from the power socket immediately.
- When cleaning or moving the air-conditioner, turn it off and unplug it.
- Do not allow children to play with the air-conditioner. When children are nearby, adult supervision is required to ensure they do not play with the unit in any manner.

Usage Notes

- The air-conditioner must be placed on flat even ground and kept vertical to ensure the normal operation of the compressor.
- There must be at least 50cm of space maintained between the air-conditioner and surrounding objects/walls.
- Do not use the air-conditioner near fuel or other flammable liquids.
- Do not use aerosol sprays or other solvents near the air-conditioner, as it may cause plastic deformation or even damage the electrical components of the unit.

Product Layout

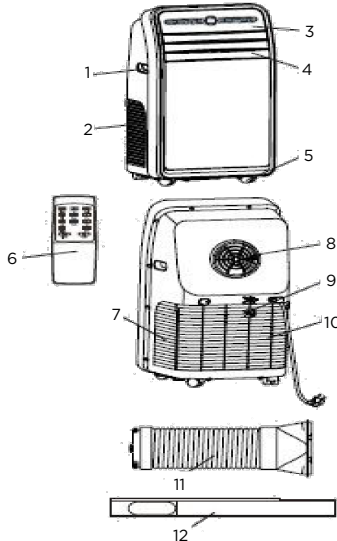
Product	Component Name
	1. Handle
	2. Air Inlet (left)
	3. Control Panel
	4. Air Guide Bars
	5. Castor Wheel
	6. Remote Control
	7. Air Inlet (right)
	8. Exhaust Air Outlet
	9. Water Drainage Outlet
	10. Inlet Grille
	11. Exhaust Pipe Assembly
	12. Window Seal Plate Assembly

Control Panel & Remote Control

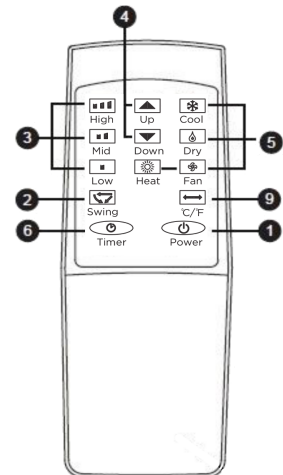
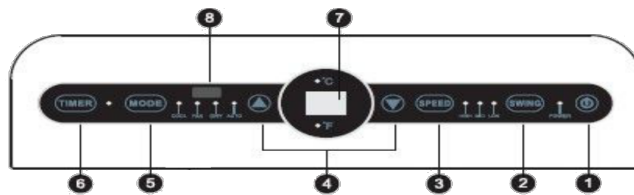

- Power Button**
Press to turn air-conditioner ON/OFF.
- Automatic Swing Function**
While in any mode, press to make the air guide bars swing automatically.
- Air Speed Function**
Press to select between high, medium and low air speeds.
- Temperature/Time Up and Down Adjustment**
When operating in cooling mode, press up or down to set the desired temperature. When in timing mode, press to adjust the on/off times. Pressing the up and down buttons together at the same time will display the conversion between fahrenheit and celsius temperatures.
- Mode Selection**
Press to select cool, fan, dry or heat modes.
- Time Function**
In standby mode, press to set the start time;
In running mode, press to set the shutdown time.
- Temperature/Time Display Window**
This displays the temperature and time information.
- Remote Control Receiver Window**
This small window houses the receiver for the remote control signals.
- Celsius/Fahrenheit Conversion Button (remote control only)**

Product Usage

Placement

- Place the air-conditioner on a flat floor near a window
- To maintain good air circulation and obtain the optimum air-conditioning performance, ensure there is 50cm of space around the unit.

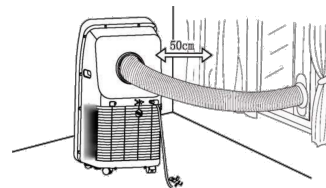

Installation

Exhaust Pipe Assembly

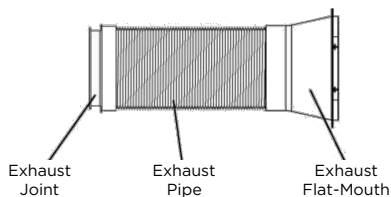

Window Seal Plate Assembly

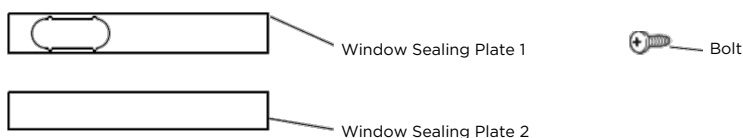

Step One

- Measure the window size.
- Adjust the length of the window sealing plate, making it to fit the size of the window.
- Once the length of the window sealing plate is determined, fix its length into place with the bolt.

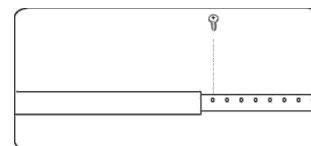

Step Two

Install the fixed window sealing plate into the window as required.

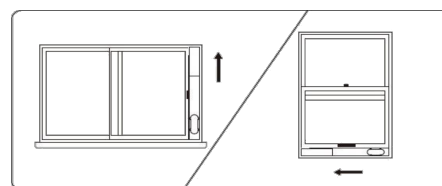

Step Three

Screw the exhaust pipe assembly (exhaust joint end) into the rear panel exhaust port (counter clockwise)

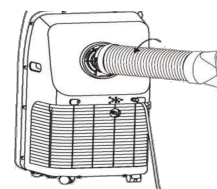

Step Four

Place the exhaust pipe assembly into the window sealing plate assembly, then fix it in place with screws.

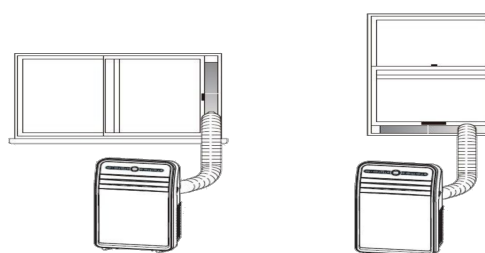

Incorrect Installation

The smoothness of the exhaust pipe is very important. Try to avoid bends in the pipe to allow the exhaust air to flow as unobstructedly as possible through the pipe.

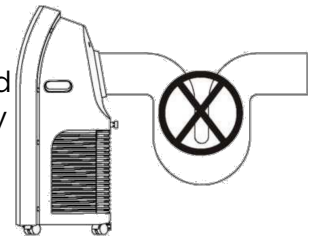

Warning: The exhaust pipe length is specially designed for this model of air-conditioner. Do not arbitrarily replace or extend it, as this can lead to product failure.

Note: The maximum length for this exhaust pipe is 1500mm. If you can compress the pipe to shorten this distance, then this will increase performance. Try to keep the pipe as level as possible.

Remote Control

Before using the remote control, please install the batteries correctly. The steps to do so are as follows:

1. Slide the battery cover on the back of the remote control open.
2. Insert 2 batteries into the battery compartment, ensuring that the polarities match the markings on the inside of the compartment.
3. Slide the battery cover back into place.

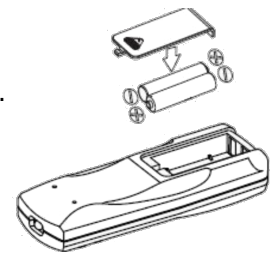

Battery Notes:

- We recommend the use of alkaline batteries with the air conditioner. Do not use rechargeable batteries.
- When replacing the batteries, replace both at the same time. Do not mix old and new batteries.
- If the air-conditioner and remote control is not being used for a long time, remove the batteries from the remote control.

Battery Warnings:

If there is a battery leak, do not touch the battery with your bare hands. Chemicals inside the battery may cause burns and other health hazards; if the battery liquid flows through onto your skin or clothing, rinse with water immediately; if it gets into your mouth, gargle with water and go straight to a hospital for urgent examination.

Unit Operation

Cool mode

- After being powered and turned on to cool mode, the cool mode indicator light will come on.
- Press the UP or DOWN button to adjust the desired temperature (17°C - 30°C).
- Press the AIR SPEED button to select high, medium or low speed.

Fan Mode

- Press the MODE button to select fan mode, and the fan indicator light will illuminate.
- Press the AIR SPEED button to select high, medium or low air speed. The temperature cannot be set in this mode.

Dry Mode

- Select dry mode by pressing the MODE button, and the dry indicator light will illuminate.
- As shown in the picture below, remove the plug from the water drainage outlet and insert a drainage hose (not included). Put the other end of the hose into a container or into a drain.
- When entering dry mode, if the room temperature is higher than 15°C, the compressor will start to work. When the room temperature drops below 13°C, the compressor will stop. If the room temperature rises up above 15°C again, the compressor will restart (the restarting of the compressor will be limited by the 3-minute delay protection function).
- In dry mode, the fan will run in low speed by default, and the air speed is not adjustable.
- Temperature cannot be set.

(Usage tip: when drying mode is being used, the exhaust hose assembly should be removed, or else the dehumidifying effect may be lessened, or you may receive the "FL" full water tank alarm.)

Heat Mode

- Select heat mode by pressing the MODE button, then the heat mode indicator light should illuminate.
- Press the UP or DOWN buttons to adjust the desired temperature (17°C ~ 30°C).
- Press the AIR SPEED button to select high, medium or low speed.

Timer Mode

- In standby mode, press the TIME button to set a time start. Press the UP and DOWN button to set the time (0 ~ 24 hours), and the time indicator light will illuminate.
- In running mode, press the TIME button to set a switch-off time. Press the UP and DOWN buttons to set the time (0 ~ 24 hours), and the time indicator light will illuminate.

Cleaning and Maintenance

Drainage Method

This unit has an automatic water evaporation system. The circulation of condensed water cools the condenser. This not only increased refrigeration efficiency but also saves energy. If the air-conditioners water tank does become full, the screen will display "FL" accompanied by an audible alarm, and the compressor will stop working automatically. At this point, you will need to drain the water tank. The method to do so is as follows:

1. Unplug the power cord and remove the exhaust pipe assembly.
2. Move the conditioner to an appropriate location.
3. Disconnect the plug in the water drainage outlet and the water will drain.
4. Replace the plug into the drainage outlet.
5. Reinstall the exhaust pipe assembly and restart the unit.

Note: to avoid electric shock, turn off the air-conditioner and unplug it from the power supply before conducting any maintenance or cleaning.

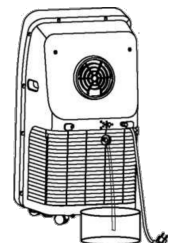

Case Cleaning

1. Remove plug from power supply.
2. Wipe with a soft cloth. Do not use any cleaning agents or rubbing alcohol on the surface as it may cause damage.
3. Do not let any liquids get into the internal parts of the air-conditioner.



Filter Screen

It is recommended that you clean the filter screen once every two weeks. If the air quality is poor, then more frequent cleaning may be required. If the filter becomes clogged with dust, the effective operation of the unit will be reduced. Screen cleaning steps are as follows:

1. Remove plug from power supply.
2. Remove the air intake grille and then the filter screen as shown in the image.
3. Put the filter screen into neutral detergent water or warm water to clean, then place in the shade to dry.
4. Reinstall the cleaned, dry filter screen.
5. Plug unit into power supply, restart it and run as normal.

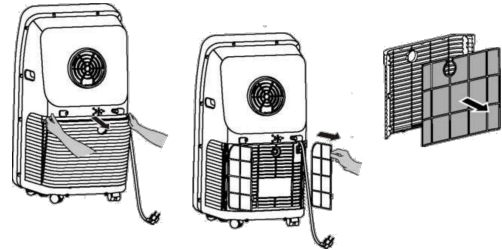

If the filter screen does not appear to be too dirty or dust is barely visible, then you can clean it with a vacuum cleaner to suck up any dust.

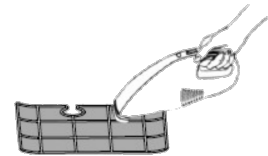

In order to avoid filter screen deformation keep the filter screen away from any sources of heat while drying.

Do not operate the air conditioner without the filter screen installed.

Seasonal Maintenance

If the air-conditioner will not be used for a long time, the maintenance steps are as follows:

1. Remove the plug from the drainage outlet and allow all water to drain out.
2. Keep the air-conditioner working for 2 hours in fan mode until the insides are dry.
3. Turn unit off, then unplug from the power supply.
4. Clean the screen filter, then reinstall into unit.
5. Remove the exhaust pipe and accessories and store them safely.
6. Remove the batteries in the remote control.
7. Put a large plastic bag (such as a garbage bag) over the air-conditioner, then store it in a cool, dry place.

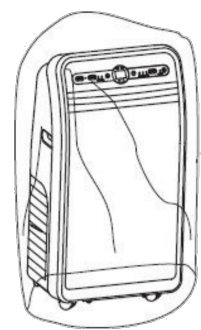

When resuming use after a long break, check the integrity of the power cord and plug. If there are cracks or breakages, do not use the air-conditioner. Ensure that the water plug and filter screens are both correctly installed.

Common Failures & Diagnostics

Intelligent Failure Detection

Error Code	Multi-Function Testing
E1	Coil temperature sensor failure
E2	Indoor temperature sensor failure
E4	Anti-freeze protection: when the coil temperature is below 0°C, the whole machine will stop. When the coil temperature rises back up to 8°C or higher, the anti-freeze protection will cease and the unit will resume working.

Breakdown Maintenance

The following table lists the common failures and the maintenance methods for the portable air-conditioner. When the unit runs abnormally, the following table may help diagnose the issue and suggest a resolution method. If the issue cannot be resolved, please contact the Kogan.com customer support team.

Problem	Possible Cause	Solution Suggestion
Air-conditioner does not work.	No Power	Check power socket is plugged in and turned on.
	Screen displays "FL"	Check that water tank isn't full of water.
	Off-timer function is activated.	Restart unit again once it has been turned off for 3 minutes.
Air-conditioner doesn't seem to be effective.	Direct Sunlight	Close curtains.
	Doors and windows are open, or there are too many people or heat sources.	Close doors and windows, and remove any non-essential heat sources.
	Air-inlet or outlet is blocked.	Remove the blockage.
Air-conditioner is noisy.	The air-conditioner base is not located on a flat surface.	Place unit on a flat, solid surface.
Compressor is not working.	Compressor delay protection has been activated.	Wait for 3 minutes, then restart the air-conditioner once it's temperature has been reduced.

Specifications

Power: 220-240VAC, 50HZ

