

Installation Guide

Bath Media Module

K-175

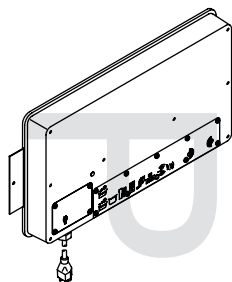

M product numbers are for Mexico (i.e. K-12345**M**)
Los números de productos seguidos de **M** corresponden a México
(Ej. K-12345**M**)
Français, page "Français-1"
Español, página "Español-1"

THE BOLD LOOK
OF **KOHLER**®

IMPORTANT INSTRUCTIONS



WARNING: When using electrical products, basic precautions should always be followed, including the following:



DANGER: Risk of electric shock. Connect only to circuits protected by a Ground-Fault Circuit-Interrupter (GFCI) or Residual Current Device (RCD). **Grounding is required.** The unit should be installed and grounded by a qualified service representative.



WARNING: Risk of electric shock. A licensed electrician should route all electrical wiring.



WARNING: Risk of electric shock. Disconnect power before servicing.



WARNING: Risk of injury or property damage. Please read all instructions thoroughly before beginning installation.



CAUTION: Risk of electric shock or product damage. Make sure the power cord is unplugged before removing the access covers.



CAUTION: Risk of product damage. The media module is rated to operate in temperatures up to 104°F (40°C). Do not install in any location where the temperature may exceed 104°F (40°C).

NOTICE: Follow all plumbing, electrical, and building codes.

NOTICE: Provide generous, unrestricted service access to the media module. Provide access for servicing. This access must be located immediately next to the media module. Refer to the roughing in information.

FCC and IC Compliance

The term "IC:" before the certification/registration number only signifies that the Industry Canada technical specifications were met.

Contains:

Kohler Company

Model #: 1070734

IC: 4554A-KOHLER044

FCC ID: N82-KOHLER004

Operation is subject to the following two conditions:

1. This device may not cause interference, and
2. This device must accept any interference, including interference that may cause undesired operation of the device.

This device complies with Part 15 of the FCC Rules. Operation is subject to the following two conditions:

1. This device may not cause harmful interference, and
2. This device must accept any interference received, including interference that may cause undesired operation.

NOTE:

Changes or modifications not expressly approved by the party responsible for compliance could void the user's authority to operate the equipment.

FCC and IC Radiation Exposure Statement for Mobile Devices

This equipment complies with FCC and IC radiation exposure limits set forth for an uncontrolled

FCC and IC Compliance (cont.)

environment. This equipment should be installed and operated with a minimum distance of 7-7/8" (20 cm) between the radiator and your body. The transmitter must not be co-located or operating in conjunction with any other antenna or transmitter.

PROOF

Specifications

Interface

Ambient Temperature	Max 125°F (52°C)
Maximum Relative Humidity	100% condensing (External surface only)
Digital Interface Cable Length (supplied with digital interface)	30 ft (9.14 m)

Media Module

Ambient Temperature	Max 104°F (40°C)
Maximum Relative Humidity	95% non-condensing
Electrical Service	100-240 V, 50/60 Hz, 2.0-0.83 A
Media Module	100-240 V, 50/60 Hz, 2.0-0.83 A
Valve Cable Length (supplied)	30 ft (9.14 m)
Line-in Cable Length	5.6 ft (1.71 m)
Ethernet Cable Length	30 ft (9.14 m)

Tools and Materials



Level

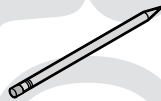

Pencil



Measuring Tape

Plus:

- 1" Hole Saw

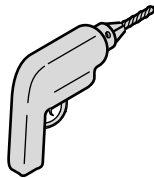

Drill

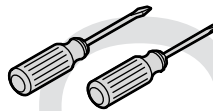

Screwdrivers

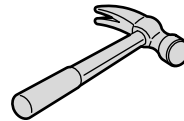

Hammer

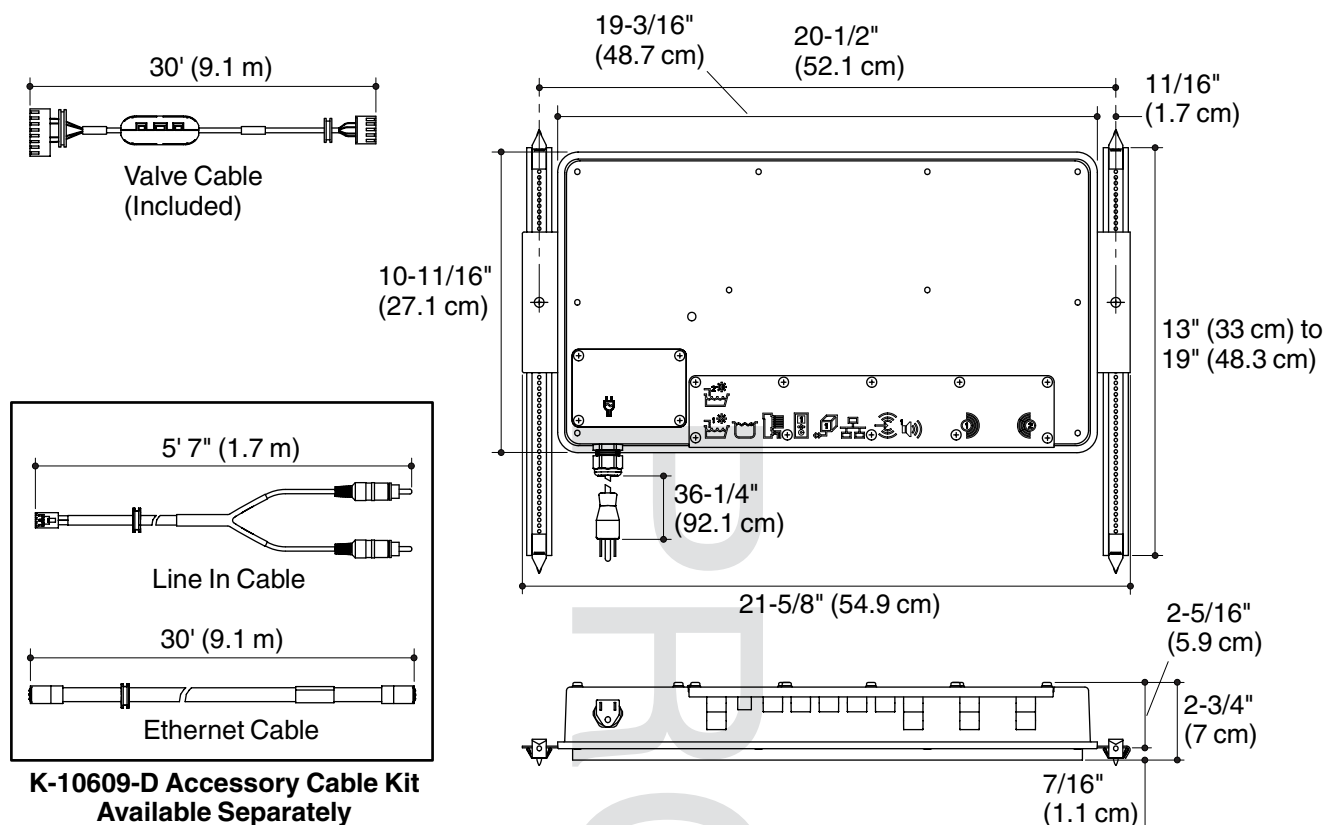

Roughing-In

Before You Begin

- Observe all local plumbing, building, and electrical codes.
- Read these instructions and determine all required components along with their installation locations before beginning this installation.
- This manual covers horizontal installation under the bath surround. An access panel must be provided for servicing.
- The media module may also be mounted horizontally under the floor joists. If mounting under the floor, the unit must not be enclosed.
- A licensed electrician should install a 15 A 120 V GFCI electrical outlet, within the stud framing, in close proximity to the media module.
- If possible, install the electrical outlet prior to installing the media box.
- This media module complies with UL, CSA, and FCC.
- To play your personal music files, you must have one of the following music servers on your personal computer: Microsoft® Windows® Media Connect, iTunes®, Rhapsody™, Yahoo!, Musicmatch® Jukebox, or Firefly Media Server. For information regarding configuring your music server, refer to the User Interface User Manual.
- For best internet music performance, your computer must have a high speed internet connection.
- Kohler Co. reserves the right to make revisions in the design of our products without notice, as specified in the Price Book.

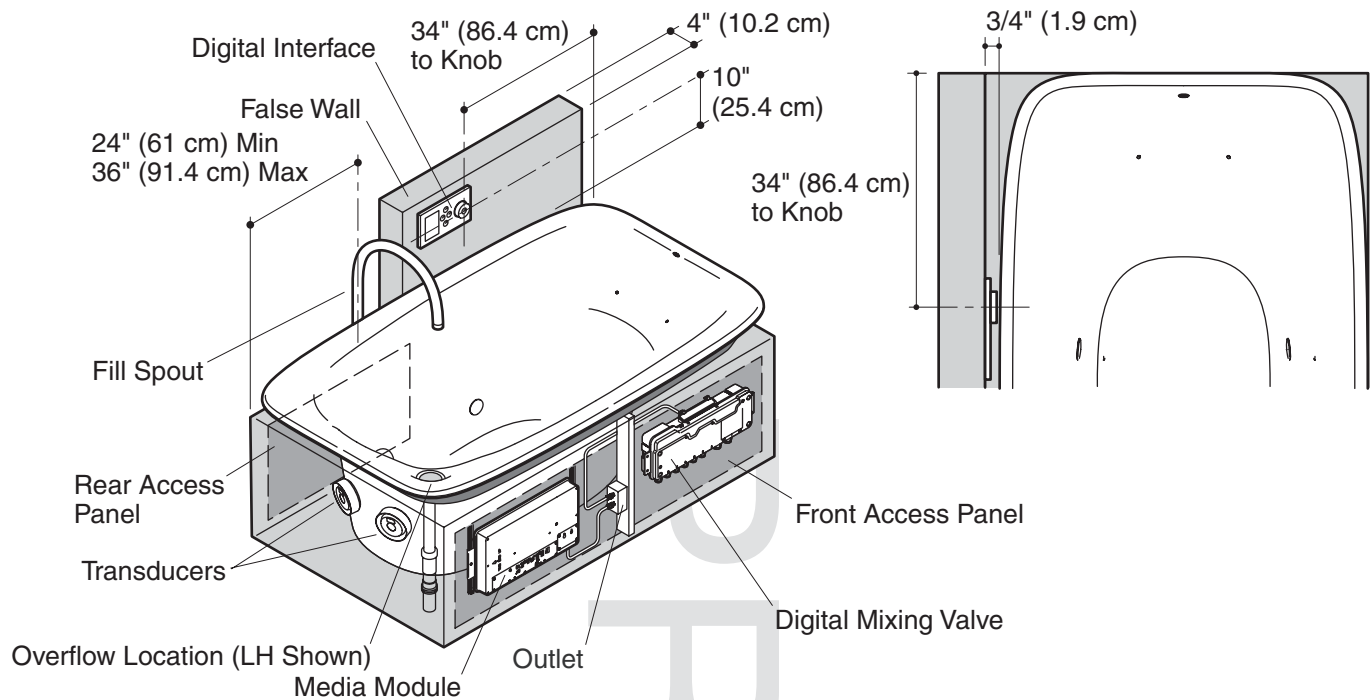

Installation Overview

For best results, follow the recommended installation sequence below. Refer to content in this guide as well as the Installation Guides packed with each component of your bathing system.

NOTE: Illustration above shows a typical installation with the preferred installation locations for the digital interface, media module and the digital mixing valve (optional).

Recommended Installation Sequence

- Determine the installation location for the media module, and digital mixing valve (if used).
- Frame the island for the bath. Provide a properly dimensioned stud pocket for the media module (required) and the digital mixing valve (optional).
- Determine the location for the access panels (required) for servicing the bath transducers, media module, and digital mixing valve (if used). Plan the island construction accordingly.
- Install the island deck. Use the cut-out templates supplied with the bath when preparing the deck.
- Frame the false wall for the digital interface.
- Route all plumbing to include: supply lines (spout and handshower), drain line, and valve (if applicable).
- Install the electrical outlet(s) in close proximity to the media module and valve (optional) installation location(s).
- Route the Ethernet cable to a router, if applicable.
- Route the digital interface cable to the media module.
- Finish the false wall.
- Install the digital interface and media module. Follow the installation instructions packed with each product.
- Install the bath and drain.
- Connect all cables.
- Finish the island walls and install the front and rear access panels.

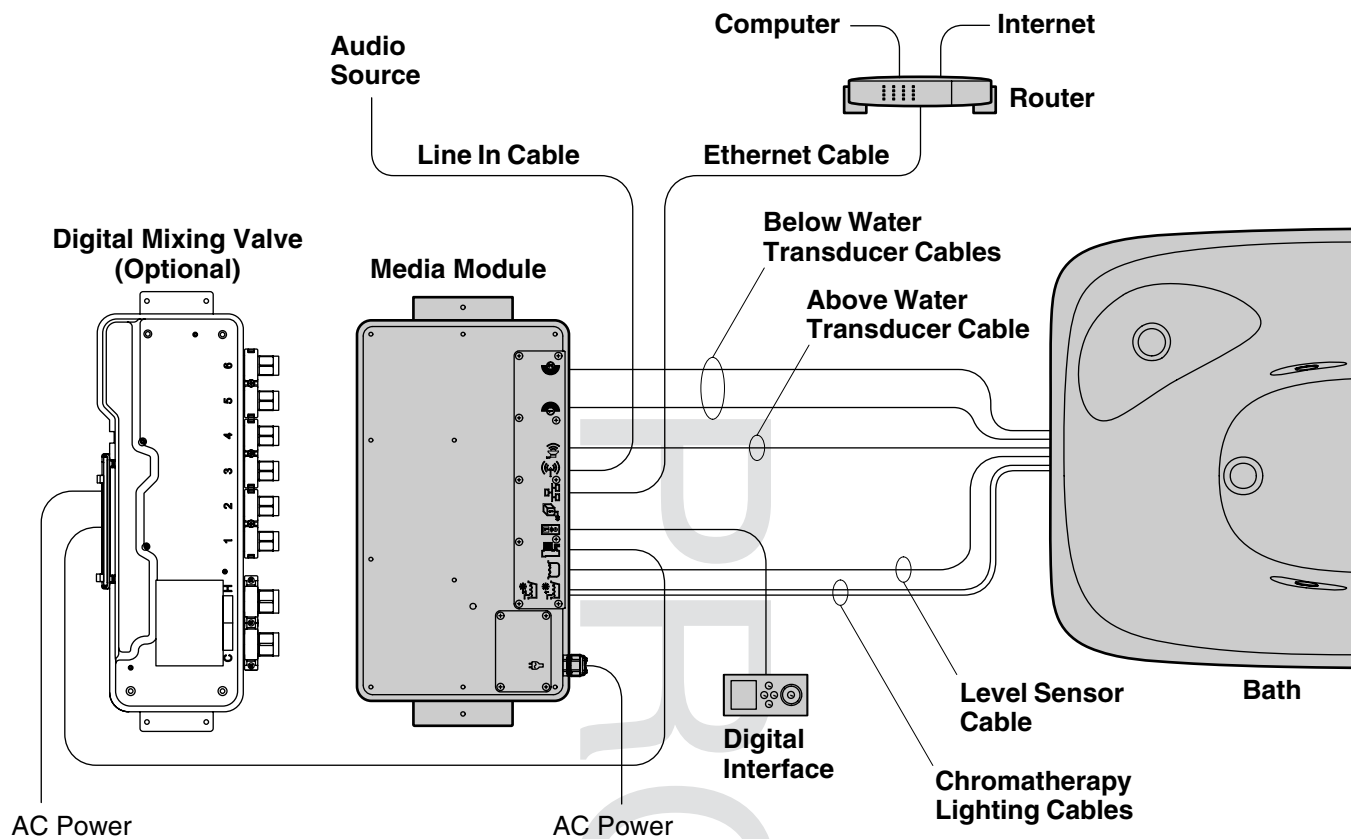

1. Determine Components

The media module controls the digital mixing valve, transducers, "Smart Fill" level sensor, chroma lighting, and music via the digital interface.

Cables are available for connecting audio (line in) and Ethernet to the media module.

Note: Wireless Ethernet is an option with the media module. However, a wired Ethernet connection is recommended.

- Determine all required components along with their installation locations before beginning the media module installation.
- Refer to the installation guides packed with each product for specific installation needs.

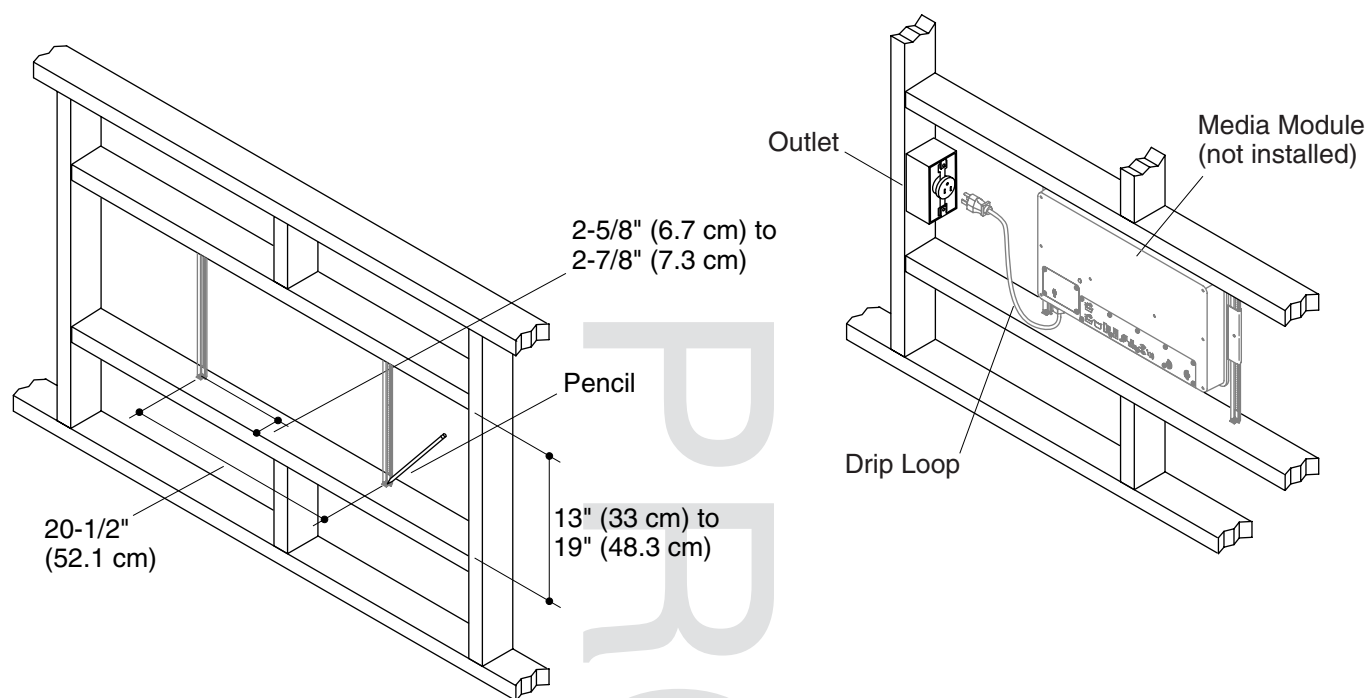

2. Prepare the Site



CAUTION: Risk of product damage. The media module is rated to operate in temperatures up to 104°F (40°C). Do not install in any location where the temperature may exceed 104°F (40°C).

- The media module is designed to fit within a 13" (33 cm) to 19" (48.3 cm) wide 2x4 stud cavity. The cavity should be free of cross bracing and insulation.
- Brackets should be positioned 20-1/2" (52.1 cm) apart. Allow enough room to one side of the media module to accommodate the electrical outlet installation and power cord connection.
- Measure 2-5/8" (6.7 cm) to 2-7/8" (7.3 cm) in from the stud face to determine the bracket placement.
- Mark the bracket locations with a pencil.
- Install a 15 A 120 V GFCI electrical outlet within the stud framing, in close proximity to the media module.
- If used, run the Ethernet cable to the media module installation site.

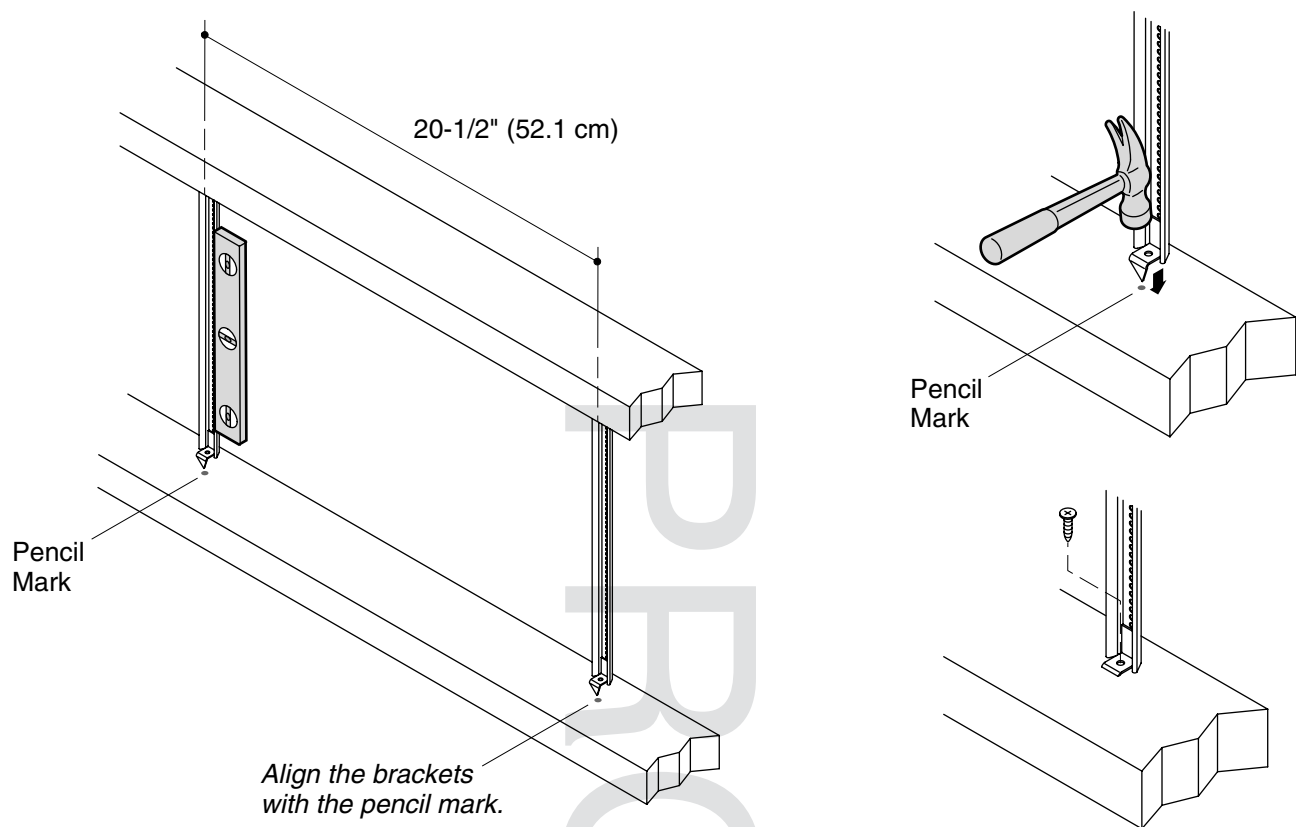

3. Install the Mounting Brackets

- Align the point of the bracket with the marked locations on the studs.
- Hammer one end of the bracket into the stud until the point is embedded.
- Level the bracket horizontally and repeat the steps to secure the other end of the bracket to the opposite stud.
- Secure the ends of the bracket using the supplied screws.
- Repeat steps to install the second bracket in the stud cavity.

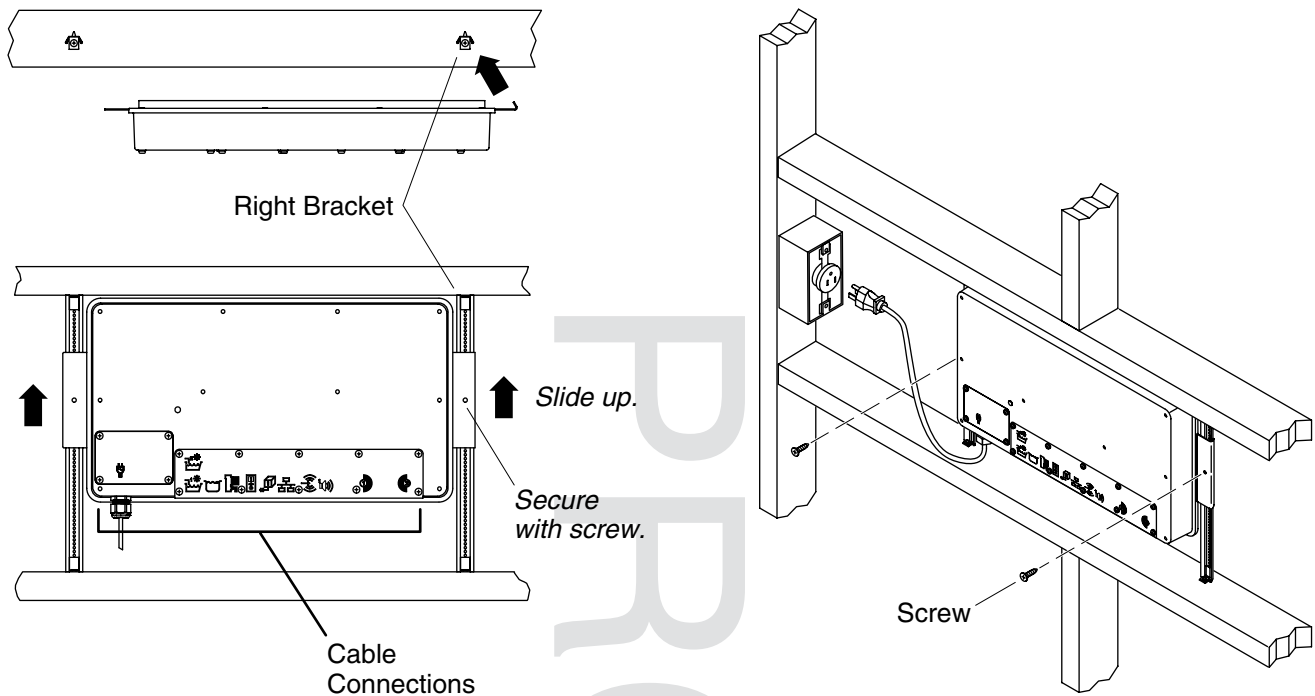

4. Install the Media Module

- Orient the media module horizontally with the connection ports facing down.
- Hook the end of the media module with the bent flange onto the right bracket.
- Slide the media module to the top of the stud cavity to allow access for the cable connections below.
- Secure the module to the right and left brackets with the screws.

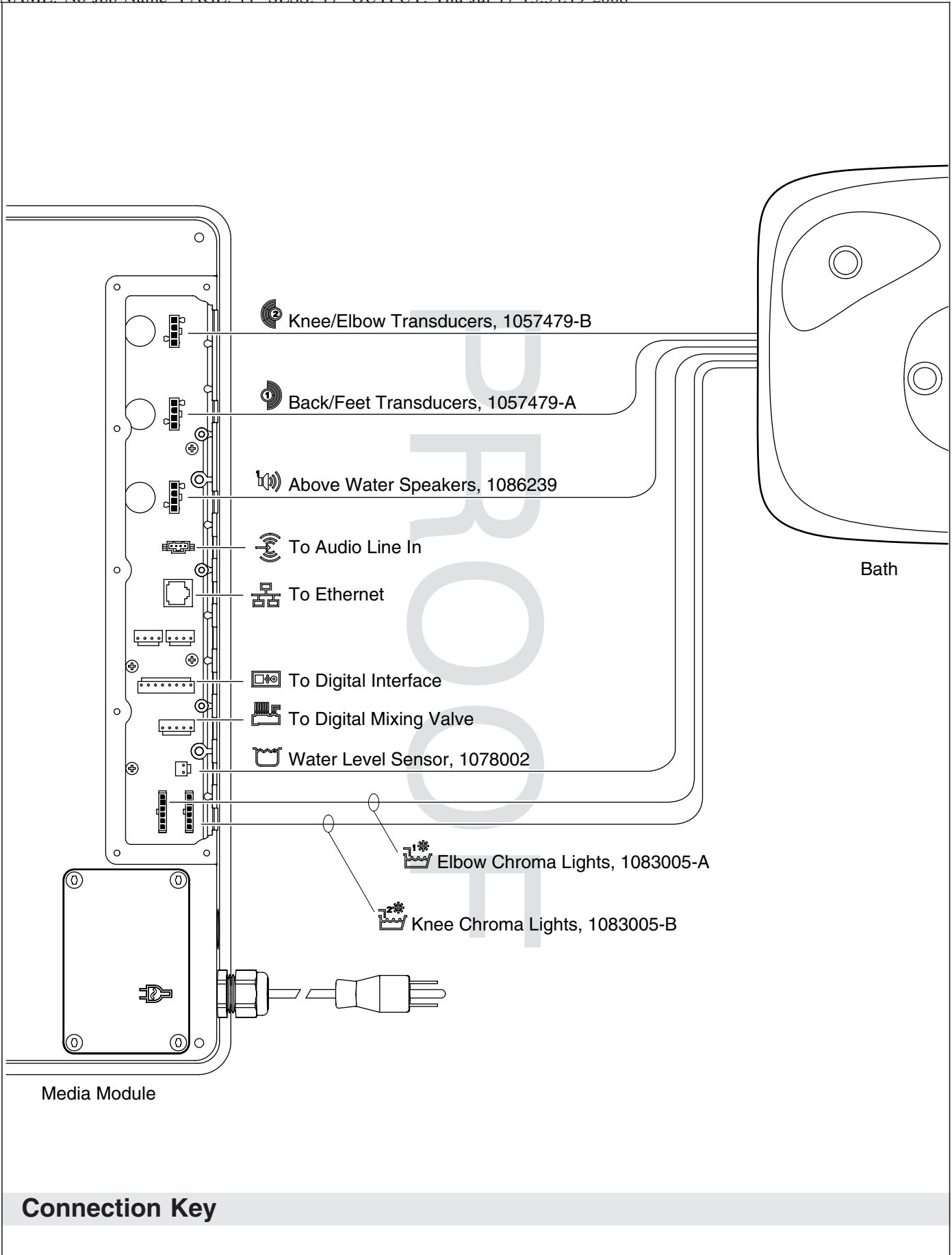

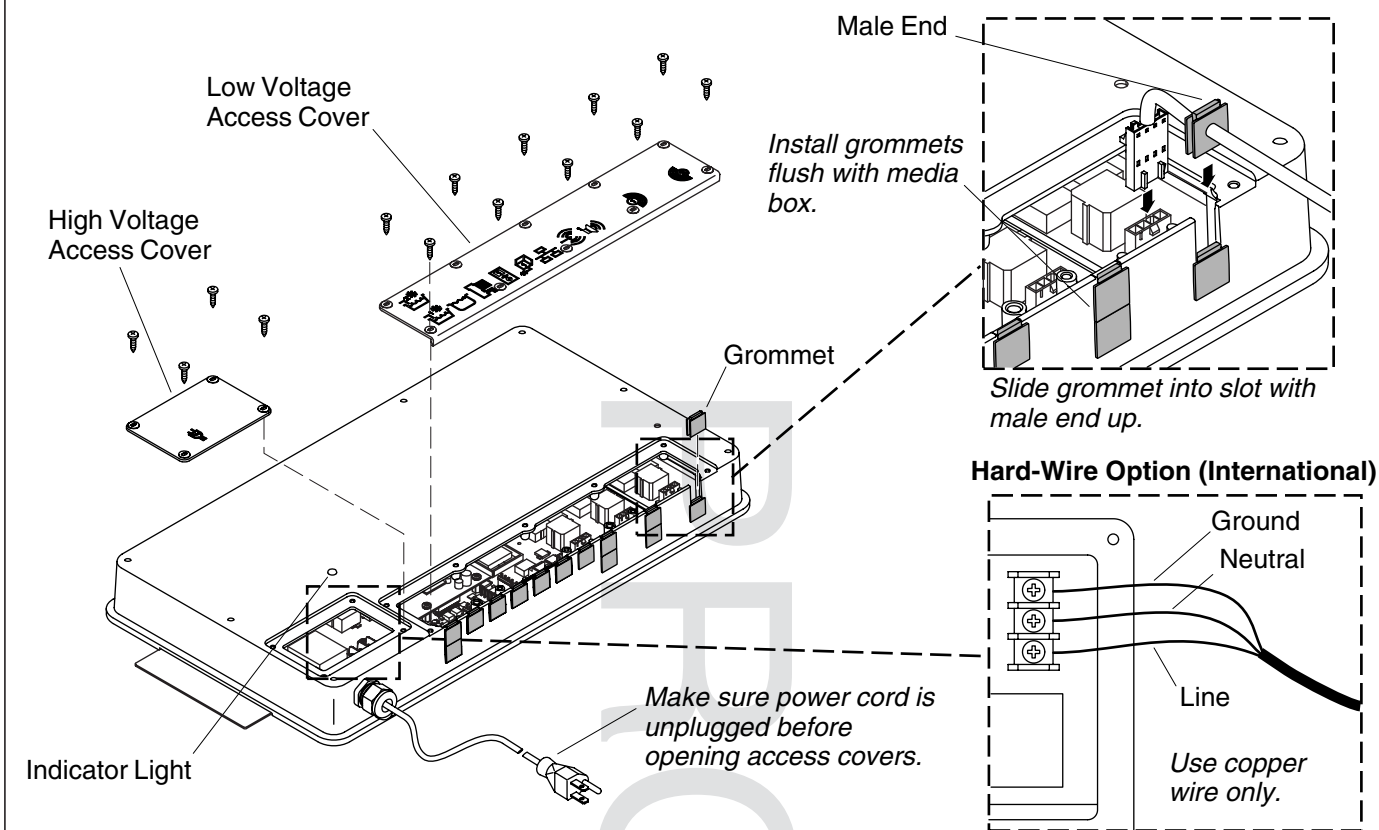

5. Connect the Components



CAUTION: Risk of electric shock or product damage. Make sure the power cord for the media module is unplugged or the power supply is turned off before removing the access covers.

Low Voltage Connections – Controls and Components

Note: For wireless applications an Ethernet connection is not needed.

- Remove the low voltage access cover.
- Remove the grommets in the locations where the cables will be installed. Refer to the "Connection Key."
- Gently press each connection until it snaps together.
- Slide the cable grommet into the slot with the male end up. Verify the grommet is properly seated.

High Voltage Power Connection – International Installations

IMPORTANT! Use only copper wire for the high voltage connection.

- Remove the high voltage access cover.
- Remove the power cord.
- Secure the power cabling to the media module using the watertight strain relief fitting (provided).
- Connect the wire for line, neutral, and ground according to the above illustration. Secure each wire to the appropriate terminal.

All Connections

- Reinstall the access covers. Do not overtighten.

Connect the Components (cont.)

- Plug the power cord into the outlet, or for hard-wire options, turn on the power. Verify that the indicator light turns on and pulses.
- Test each component to ensure proper functionality. Refer to the Installation and Homeowner Guides packed with each of the individual components for additional information.

6. Complete the Installation

- Reinstall the access covers. Do not overtighten.
- If not already installed, install any additional components at this time according to the installation instructions packed with the products. For connecting to the media module, refer to the "Connect the Components" section.
- Plug the power supply into the outlet. Verify that the indicator light turns on and pulses.
- Configure your music server and Ethernet. Refer to the Media Module Homeowner's guide.

7. Installation Checkout

- Test each component to ensure proper functionality. Refer to the Installation and Homeowners Guides packed with each of the individual components for additional information.

Troubleshooting

CAUTION: Risk of personal injury. The valve (if installed) may contain hot water; be careful when draining any residual water.

IMPORTANT! Turn off the power and water supply to all components before performing any maintenance.

It is recommended that any valve maintenance should be performed by a Kohler Co. Authorized Service Representative.

This troubleshooting guide is for general aid only. For service and installation issues or concerns, call 1-800-4-KOHLER.

Interface Troubleshooting Table

Symptoms	Probable Cause	Recommended Action
1. Digital interface is not lit.	<p>A. Media module is not plugged into the outlet.</p> <p>B. Power supply connection to the media module may be loose or disconnected.</p> <p>C. Interface cable connections may be loose or disconnected.</p> <p>D. Circuit breaker has been tripped.</p> <p>E. The media module may require resetting.</p> <p>F. If none of the recommended actions for the above issues correct the symptom, the media module or interface requires servicing.</p>	<p>A. Plug the media module into the outlet.</p> <p>B. Check power supply connections to the media module and reconnect if needed.</p> <p>C. Check all interface cable connections, connect if needed.</p> <p>D. Reset the circuit breaker.</p> <p>E. Disconnect and reconnect the power supply from the media module.</p> <p>F. Contact your Kohler Co. Authorized Service Representative.</p>
2. The interface power indicator pulses but does not turn on.	<p>A. Interface cable connections may be loose or disconnected.</p>	<p>A. Check all interface cable connections, connect if needed.</p>

Troubleshooting (cont.)		
Interface Troubleshooting Table		
Symptoms	Probable Cause	Recommended Action
	<p>B. The media module requires resetting.</p> <p>C. If the above recommended action does not correct the symptom, the interface or media module requires servicing.</p>	<p>B. Disconnect and reconnect the media module power supply.</p> <p>C. Contact your Kohler Co. Authorized Service Representative.</p>
<p>3. The interface functions normally but no water flows from the spout or handshower.</p>	<p>A. Inlet/outlet fittings may be blocked.</p> <p>B. Outlets are not plumbed correctly.</p> <p>C. Hot and cold water supplies are not turned on.</p> <p>D. The valve or media module memory may require resetting.</p> <p>E. System error.</p> <p>F. If none of the recommended actions for the above issues correct the symptom, the media module requires servicing.</p>	<p>A. Check the inlets and outlets for blockage or debris. Clean the inlet screens. Refer to the "Clean the Inlet Screens" section in the Valve Homeowners Guide.</p> <p>B. Reroute plumbing as needed.</p> <p>C. Turn on the water supply to the valve.</p> <p>D. Disconnect and reconnect the power supply from the valve and media module.</p> <p>E. Check the user interface for an error code. Refer to the "Diagnostics" section in the Digital Interface Homeowners Guide.</p> <p>F. Contact your Kohler Co. Authorized Service Representative.</p>
<p>4. Display is difficult to read.</p>	<p>A. Contrast is not optimized.</p> <p>B. Brightness is not optimized.</p>	<p>A. Adjust contrast in the user interface setting menu.</p> <p>B. Adjust the brightness in the user interface setting menu.</p>
Valve Troubleshooting Table		
Symptoms	Probable Cause	Recommended Action
<p>1. Maximum blend temperature too hot or too cold.</p>	<p>A. Incorrect maximum temperature setting.</p> <p>B. Inlet/outlet fittings may be blocked.</p> <p>C. If the above recommended action does not correct the symptom, the interface or valve requires servicing.</p>	<p>A. Refer to the "Set the Maximum Temperature" section in the Digital Interface User Guide.</p> <p>B. Check the inlets and outlets for blockage or debris. Clean the inlet screens. Refer to the "Clean the Inlet Screens" section in the Valve Homeowners Guide.</p> <p>C. Contact your Kohler Co. Authorized Service Representative.</p>
<p>2. Continuous flow.</p>	<p>A. System will not switch off.</p>	<p>A. Turn off the water and power supply and contact your Kohler Co. Authorized Service Representative.</p>
<p>3. Handshower does not work.</p>	<p>A. Handshower is not enabled.</p>	<p>A. Enable the handshower option in the settings menu. Refer to the Digital Interface User Guide.</p>
<p>4. Only cold water flows from the outlets.</p>	<p>A. Hot water supply is either not turned on or not connected to the valve inlet.</p>	<p>A. Check the hot water supply is turned on and connected to the valve inlet.</p>

Troubleshooting (cont.)		
Valve Troubleshooting Table		
Symptoms	Probable Cause	Recommended Action
	<p>B. Hot water inlet is blocked.</p> <p>C. If none of the recommended actions for the above issues correct the symptom, the valve requires servicing.</p>	<p>B. Check the hot water inlet screen for blockage. Clean or replace the inlet screen. Refer to the Valve Homeowners Guide.</p> <p>C. Contact your Kohler Co. Authorized Service Representative.</p>
<p>5. Fluctuating or reduced flow rate. Valve is functioning properly.</p>	<p>A. Inlet/outlet fittings may be blocked.</p> <p>B. Water outlet pressure is low.</p> <p>C. Fluctuating flow.</p> <p>D. If none of the recommended actions for the above issues correct the symptom, the valve requires servicing.</p>	<p>A. Check the inlets and outlets for blockage or debris. Clean the inlet screens. Refer to the "Clean the Inlet Screens" section in the Valve Homeowners Guide.</p> <p>B. Check that the flow rate is at or above the minimum rate required. Refer to "Specifications" section in the Valve Homeowners Guide.</p> <p>C. Verify that the dynamic inlet pressures are within specifications. Refer to "Specifications" section in the Valve Homeowners Guide.</p> <p>D. Contact your Kohler Co. Authorized Service Representative.</p>
<p>6. Blend temperature drift or temperature cycling.</p>	<p>A. Fluctuating water temperature.</p> <p>B. Hot water supply temperature fluctuation.</p> <p>C. Pressure difference greater than 5 psi (34.5 kPa) between the hot and cold supply lines.</p> <p>D. If none of the recommended actions for the above issues correct the symptom, the valve requires servicing.</p>	<p>A. Check the inlet temperature differentials and verify they are sufficient. Refer to "Specifications" section in the Valve Homeowners Guide.</p> <p>B. Check and make adjustments as needed.</p> <p>C. Install pressure regulators to bring the supplies within 5 psi (34.5 kPa) of each other.</p> <p>D. Contact your Kohler Co. Authorized Service Representative.</p>
<p>7. Water leaking from the valve. CAUTION: Risk of personal injury or product damage. Turn off the main power and water supply.</p>	<p>A. Connections are not secure.</p> <p>B. Seals are worn or damaged.</p> <p>C. Internal leak.</p>	<p>A. Check all connections. Make adjustments as needed.</p> <p>B. Order a seal service pack and replace all seals.</p> <p>C. Unit requires overhaul. Contact your Kohler Co. authorized service representative.</p>
<p>8. Hot water only, the valve shuts down.</p>	<p>A. Hot and cold lines are reversed.</p>	<p>A. Switch hot and cold water supply connections. Verify the hot water supply is connected to the inlet marked "H" and the cold water supply is connected to the inlet marked "C."</p>

Troubleshooting (cont.)		
Music Troubleshooting Table		
Symptoms	Probable Cause	Recommended Action
1. Bath transducers do not produce sound.	A. Transducer cables are not connected properly.	A. Make sure the cables are properly installed into the Media Module connections and to the bath transducers.
2. After playing music loudly, the music stops even though a song is properly selected.	A. Thermal shut down.	A. Shut down the system for 1 hour to allow the unit to cool. Make sure the area where the unit is installed does not exceed 104°F (40°C).
3. Library menu is not available.	A. The Roku agreement was declined.	A. Enter the settings menu, select "System," select "Music Software," select "Roku Agreement" and select "YES."
4. Music server is not available.	A. Wireless connection out of range. B. Wireless network is not configured properly. C. The network cable is not connected to the correct router/switch input. D. A compatible media server is not installed/running on your home computer. E. The media server on your home computer is not configured to share files. F. The incorrect Wi-Fi region was selected.	A1. Move router closer or install a wireless access point. A2. Connect via Ethernet cable. B. Enter the settings menu, select "System," select "WiFi Security," select "Network Name," select "WEP/WPA Key" and enter the security key. C. Connect the Media Module to the router's/switch's Ethernet ports. D. Install/open one of the supported media servers such as Firefly Media Server, iTunes®, Microsoft® Windows® Media Connect, Rhapsody™, Yahoo! or Musicmatch® on your computer and load your favorite music into the server's library. E. Reference the media server's help menu to properly configure file sharing. F. Enter the settings menu, select "System," select "Music Software," select "Region" and select the appropriate geographical region that matches your Wi-Fi router.
5. I have a wireless network but my Media Module is unable to connect to the network.	A. Ethernet cable is plugged in. B. Media Module is not within Wi-Fi range. C. A WEP or WPA key was not entered for your secured network. D. The router is not set up for 802.11b.	A. Unplug the Ethernet cable. B. Make sure the Media Module is within range of your Wi-Fi network. C. Enter the settings menu, select "System," select "WiFi Security," select "Network Name," select "WEP/WPA Key" and enter the security key. D. Make sure the access point/router is configured to allow 802.11b clients.

Troubleshooting (cont.)**Music Troubleshooting Table**

Symptoms	Probable Cause	Recommended Action
6. The Media Module cannot connect to an iTunes server with firewall software running.	A. The firewall is not configured correctly to allow iTunes music sharing.	A. Make sure your firewall software is configured to allow iTunes music sharing. For a Mac: Open System Preferences. Select the Sharing icon and click on the firewall tab. Select the option "iTunes Music Sharing." For a PC: Refer to your documentation for changing firewall settings. If running Windows XP service pack 2, open "Security Center," select "Windows Firewall," click on the "Exceptions" tab, and check to see that iTunes is enabled. If not, use "Add Programs" to enable it. After these changes have been made, restart the Media Module by disconnecting and reconnecting the AC power.
7. The Media Module cannot access the iTunes library.	A. iTunes is not running. B. iTunes is not configured for sharing. C. iTunes is not responding to commands from the Media Module.	A. Make sure the computer containing your iTunes library is turned on and iTunes is running. B. In iTunes, be sure to turn on the "music sharing" option. Go to the iTunes>Preferences menu or Edit>Preferences for PC users. In the dialog box that appears, click the "Sharing" icon, then check the option "Share my music" to enable sharing on your local network. C. Close and restart iTunes on your computer.
8. I can see my iTunes library in the list of libraries, but when I try to connect, the connection fails.	A. iTunes is not configured for sharing.	A. In iTunes, be sure to turn on the "music sharing" option. Go to the iTunes>Preferences menu or Edit>Preferences for PC users. In the dialog box that appears, click the "Sharing" icon, then check the option "Share my music" to enable sharing on your local network.

Troubleshooting (cont.)		
Music Troubleshooting Table		
Symptoms	Probable Cause	Recommended Action
	<p>B. No IP address assigned to the Media Module.</p>	<p>B. The Media Module was not assigned an IP address via DHCP, but the PC was. In this situation, the Media Module is able to see the library via Rendezvous, but is not able to connect to the library. Here is how to check your Media Module's address: Enter the settings menu, select "System," select "Music," select "Roku IP Address." If your IP address is of the form 169.254.xxx.xxx, the Media Module did not get a DHCP-assigned address. Check the configuration of your router to ensure it is set up to assign DHCP addresses. Reboot the Media Module by disconnecting and reconnecting the AC power.</p>
<p>9. The Media Module can not access Windows Media Connect library.</p>	<p>A. Windows Media Connect is not configured for sharing.</p>	<p>A. Make sure that your computer containing your music library is powered ON and Windows Media Connect is running (icon should be visible in the task tray). With the Media Module powered ON and connected to your network, make sure that the Media Module is an authorized device. Launch Windows Media Connect through your Control Panel. On the wizard screen, scroll down the list of devices. If the Media Module is not listed, click the "Add" button at the bottom of the list. Click on Media Module, then click "OK." It should show up on the list of authorized devices. Click "Done." Reboot the Media Module by disconnecting and reconnecting the AC power.</p>
<p>10. The Media Module can not access the Musicmatch library.</p>	<p>A. Musicmatch is not running.</p> <p>B. Musicmatch is not configured for sharing.</p>	<p>A. Make sure the computer containing your music library is powered ON.</p> <p>B. Make sure music sharing is enabled in Musicmatch. From the main Musicmatch menu, click on Options/Settings. Click on the tab "CD Lookup/Connectivity." Click the buttons next to "Enable music server" as well as "Universal Plug and Play." Musicmatch does not need to be running while using the Media Module; once enabled, the UPnP server runs in the background. Reboot the Media Module by disconnecting and reconnecting the AC power.</p>

Troubleshooting (cont.)**Music Troubleshooting Table**

Symptoms	Probable Cause	Recommended Action
11. The Media Module is connected to my network via wired ethernet, but is unable to play Internet radio and may sometimes fail to locate, connect to, or play music from my music servers.	<p>A. No IP address assigned to the Media Module.</p> <p>B. Ethernet cable is damaged.</p>	<p>A. Determine the Media Module's address by entering the settings menu, select "System," select "Music," select "Roku IP Address." If your IP address is of the form 169.254.xxx.xxx, the Media Module did not get a DHCP-assigned address. Check the configuration of your router to ensure it is set up to assign DHCP addresses. Reboot the Media Module by disconnecting and reconnecting the AC power.</p> <p>B. Replace the Ethernet cable.</p>
12. No sound plays through the bath transducers.	<p>A. The song is paused.</p> <p>B. The volume is too low.</p>	<p>A. Make sure a song is playing. If the song is paused, press the OK button to continue playback.</p> <p>B. Make sure the volume is turned up high enough for proper enjoyment.</p>
13. Some of my music files do not display while browsing.	A. Missing ID3 tag info.	A. ID3 data tags may be missing. Information about your music, including Song Name, Artist, Composer, Album, and Genre is usually created automatically by the software you used to save your audio CD files on your computer's hard drive. This process creates data called "ID3 tags" to describe each track. If this data is missing from your music files, they will not appear when you browse by that data category. You can edit this information in music jukebox software such as iTunes.
14. A music file will not play.	A. Unsupported file format.	A. Make sure your file is a supported format: iTunes Music Server: MP3, AAC, ALAC, AIFF and WAV Windows Media Player 11 / Windows Media Connect: MP3, WMA (including DRM WMA) and WAV.
15. Songs purchased through the iTunes music store will not play.	A. Song is not supported because of DRM.	A. This is normal. DRM AAC files (i.e., files purchased on Apple's music store) are not supported. Those files will be detected but will be skipped during playback.
16. I cannot find playlists that I saved on my computer.	A. Some playlists may not be supported.	A. iTunes users: Make sure your playlist was created in iTunes and is visible in your iTunes application. Windows Media Connect users: Make sure your playlists are saved in the My Documents\My Music\My Playlists or other shared folder. Musicmatch users: Musicmatch exports playlists in a manner that is not supported. Slimserver users: Make sure your playlist is a Slimserver-supported playlist format.

Troubleshooting (cont.)		
Music Troubleshooting Table		
Symptoms	Probable Cause	Recommended Action
17. I am experiencing undesirable noise or resonance.	<p>A. Apron is vibrating against the deck.</p> <p>B. Transducers resonate with deck.</p>	<p>A. Verify rubber isolator mounts are contacting the deck and insulating the apron from the deck.</p> <p>B. Make sure bath is centered in deck cutout. Transducers should not contact the framing or deck.</p>
Lights Troubleshooting Table		
Symptoms	Probable Cause	Recommended Action
1. The bath lights do not turn on.	<p>A. Cable connections are loose or disconnected.</p> <p>B. Light cables connected to wrong media module connectors.</p> <p>C. Chroma light string damaged.</p> <p>D. Media module is malfunctioning.</p>	<p>A. Make sure the cables are properly connected to the media module.</p> <p>B. Verify cables and connections, reconnect as needed.</p> <p>C. Replace chroma light string.</p> <p>D. Media module may need to be replaced. Contact your Kohler Co. Authorized Service Representative.</p>
Media Module Troubleshooting Table		
Symptoms	Probable Cause	Recommended Action
1. System stops working and the status LED is a solid red.	A. System failure.	A. Reboot the Media Module by disconnecting the AC power from the wall outlet. If the status LED remains a solid red after reboot, replace the Media Module.
2. System stops working and the Status LED is a OFF.	<p>A. Power supply failure.</p> <p>B. Incorrect wiring of the AC power supply.</p>	<p>A. Reboot the Media Module by disconnecting the AC power from the wall outlet. If there is no change after reboot, replace the Media Module.</p> <p>B. Verify that the Media Module was installed per the installation manual. Make sure AC power is present at the outlet the Media Module is plugged into.</p>
3. Music stops playing and I get a music error.	<p>A. Thermal shutdown.</p> <p>B. Incorrect speaker load.</p>	<p>A. Shut down the system for 1 hour to allow the unit to cool. Make sure the area where the unit is installed does not exceed 104°F (40°C).</p> <p>B. Verify the speaker load is 4 to 8 ohms.</p>
4. Water level sensor does not detect water.	<p>A. Level sensor cable is damaged.</p> <p>B. Level sensor cable is loose or disconnected.</p> <p>C. Water is too pure.</p>	<p>A. Replace the level sensor cable.</p> <p>B. Make sure the cable is properly connected to the media module.</p> <p>C. Add bath salts to your bathing water.</p>
5. No display on the user interface.	<p>A. The interface cable is damaged.</p> <p>B. The interface cable is not plugged in.</p> <p>C. The interface or Media Module requires servicing.</p>	<p>A. Replace the interface cable.</p> <p>B. Verify the interface cable is properly plugged into the interface at all locations.</p> <p>C. Contact your Kohler Co. Authorized Service Representative.</p>

Troubleshooting (cont.)**Media Module Troubleshooting Table**

Symptoms	Probable Cause	Recommended Action
6. Experiences are not functioning.	A. SD card is dislodged.	A. Contact your Kohler Co. Authorized Service Representative.

Remote Control Troubleshooting Table

Symptoms	Probable Cause	Recommended Action
1. Intermittent or erratic operation.	A. Frequency/channel interference.	A. Set RFID, PANID, and channel by following screen prompts on the digital interface for the remote. Then re-sync the remote as instructed in the Bath Homeowners Guide.
2. LED on remote does not blink or constantly blinks.	A. Batteries are low.	A. Replace batteries (2 AA).
3. One or more buttons on remote do not function and LED does not light up.	A. Batteries are low. B. Remote program lost. C. Remote is damaged.	A. Replace batteries (2 AA). B. Re-sync the remote to the interface. C. Replace remote.
4. One or more buttons on remote do not function but LED lights up.	A. Digital interface is malfunctioning.	A. Digital interface may need to be replaced. Contact your Kohler Co. Authorized Representative.

PROOF

PROOF

PROOF

USA: 1-800-4-KOHLER

Canada: 1-800-964-5590

México: 001-877-680-1310

kohler.com

THE BOLD LOOK
OF **KOHLER**®

©2008 Kohler Co.

1093174-2-C