

TASCAM

TEAC Professional Division

D00337200A

DA-98

Digital Multitrack Recorder

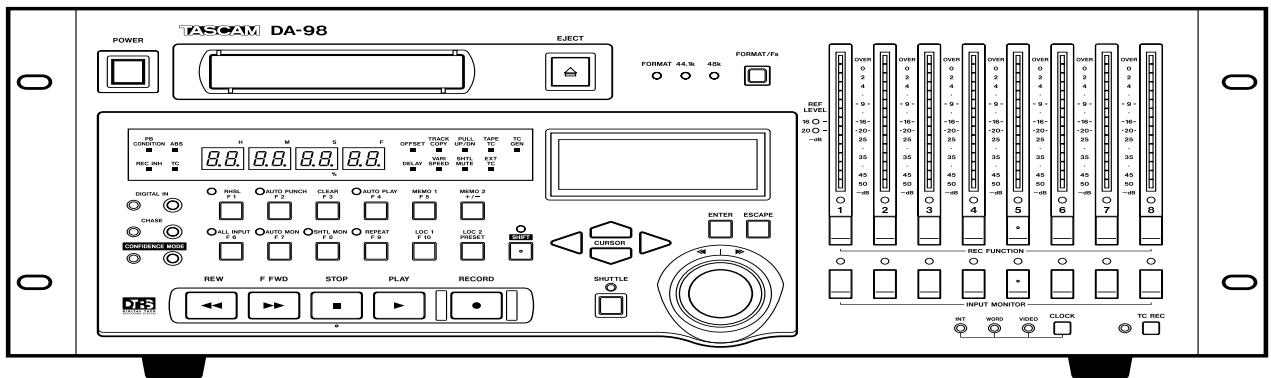

OWNER'S MANUAL



CAUTION: TO REDUCE THE RISK OF ELECTRIC SHOCK, DO NOT REMOVE COVER (OR BACK). NO USER-SERVICEABLE PARTS INSIDE. REFER SERVICING TO QUALIFIED SERVICE PERSONNEL.



The lightning flash with arrowhead symbol, within an equilateral triangle, is intended to alert the user to the presence of uninsulated "dangerous voltage" within the product's enclosure that may be of sufficient magnitude to constitute a risk of electric shock to persons..



The exclamation point within an equilateral triangle is intended to alert the user to the presence of important operating and maintenance (servicing) instructions in the literature accompanying the appliance.

This appliance has a serial number located on the rear panel. Please record the model number and serial number and retain them for your records.

Model number _____
 Serial number _____

WARNING: TO PREVENT FIRE OR SHOCK HAZARD, DO NOT EXPOSE THIS APPLIANCE TO RAIN OR MOISTURE.

Important Safety Precautions

IMPORTANT (for U.K. Customers)

DO NOT cut off the mains plug from this equipment.

If the plug fitted is not suitable for the power points in your home or the cable is too short to reach a power point, then obtain an appropriate safety approved extension lead or consult your dealer.

If nonetheless the mains plug is cut off, remove the fuse and dispose of the plug immediately, to avoid a possible shock hazard by inadvertent connection to the mains supply.

If this product is not provided with a mains plug, or one has to be fitted, then follow the instructions given below:

IMPORTANT: The wires in this mains lead are coloured in accordance with the following code:

GREEN-AND-YELLOW	: EARTH
BLUE	: NEUTRAL
BROWN	: LIVE

WARNING: This apparatus must be earthed.

As the colours of the wires in the mains lead of this apparatus may not correspond with the coloured markings identifying the terminals in your plug proceed as follows:

The wire which is coloured GREEN-and-YELLOW must be connected to the terminal in the plug which is marked by the letter E or by the safety earth symbol \equiv or coloured GREEN or GREEN-and-YELLOW.

The wire which is coloured BLUE must be connected to the terminal which is marked with the letter N or coloured BLACK.

The wire which is coloured BROWN must be connected to the terminal which is marked with the letter L or coloured RED.

When replacing the fuse only a correctly rated approved type should be used and be sure to re-fit the fuse cover.

IF IN DOUBT — CONSULT A COMPETENT ELECTRICIAN.

For U.S.A

TO THE USER

This equipment has been tested and found to comply with the limits for a Class A digital device, pursuant to Part 15 of the FCC Rules. These limits are designed to provide reasonable protection against harmful interference when the equipment is operated in a commercial environment. This equipment generates, uses, and can radiate radio frequency energy and, if not installed and used in accordance with the instruction manual, may cause harmful interference to radio communications.

Operation of this equipment in a residential area is likely to cause harmful interference in which case the user will be required to correct the interference at his own expense.

CAUTION

Changes or modifications to this equipment not expressly approved by TEAC CORPORATION for compliance could void the user's authority to operate this equipment.

For the consumers in Europe

WARNING

This is a Class A product. In a domestic environment, this product may cause radio interference in which case the user may be required to take adequate measures.

Pour les utilisateurs en Europe

AVERTISSEMENT

Il s'agit d'un produit de Classe A. Dans un environnement domestique, cet appareil peut provoquer des interférences radio, dans ce cas l'utilisateur peut être amené à prendre des mesures appropriées.

Für Kunden in Europa

Warnung

Dies ist eine Einrichtung, welche die Funk-Entstörung nach Klasse A besitzt. Diese Einrichtung kann im Wohnbereich Funkstörungen verursachen ; in diesem Fall kann vom Betreiber verlangt werden, angemessene Maßnahmen durchzuführen und dafür aufzukommen.

IMPORTANT SAFETY INSTRUCTIONS

CAUTION:

- Read all of these Instructions.
- Save these Instructions for later use.
- Follow all Warnings and Instructions marked on the audio equipment.

- 1) Read Instructions** — All the safety and operating instructions should be read before the product is operated.
- 2) Retain Instructions** — The safety and operating instructions should be retained for future reference.
- 3) Heed Warnings** — All warnings on the product and in the operating instructions should be adhered to.
- 4) Follow Instructions** — All operating and use instructions should be followed.
- 5) Cleaning** — Unplug this product from the wall outlet before cleaning. Do not use liquid cleaners or aerosol cleaners. Use a damp cloth for cleaning.
- 6) Attachments** — Do not use attachments not recommended by the product manufacturer as they may cause hazards.
- 7) Water and Moisture** — Do not use this product near water — for example, near a bath tub, wash bowl, kitchen sink, or laundry tub; in a wet basement; or near a swimming pool; and the like.
- 8) Accessories** — Do not place this product on an unstable cart, stand, tripod, bracket, or table. The product may fall, causing serious injury to a child or adult, and serious damage to the product. Use only with a cart, stand, tripod, bracket, or table recommended by the manufacturer, or sold with the product. Any mounting of the product should follow the manufacturer's instructions, and should use a mounting accessory recommended by the manufacturer.
- 9) A product and cart combination should be moved with care.** Quick stops, excessive force, and uneven surfaces may cause the product and cart combination to overturn.



- 10) Ventilation** — Slots and openings in the cabinet are provided for ventilation and to ensure reliable operation of the product and to protect it from overheating, and these openings must not be blocked or covered. The openings should never be blocked by placing the product on a bed, sofa, rug, or other similar surface. This product should not be placed in a built-in installation such as a bookcase or rack unless proper ventilation is provided or the manufacturer's instructions have been adhered to.
- 11) Power Sources** — This product should be operated only from the type of power source indicated on the marking label. If you are not sure of the type of power supply to your home, consult your product dealer or local power company. For products intended to operate from battery power, or other sources, refer to the operating instructions.
- 12) Grounding or Polarization** — This product may be equipped with a polarized alternating-current line plug (a plug having one blade wider than the other). This plug will fit into the power outlet only one way. This is a safety feature. If you are unable to insert the plug fully into the outlet, try reversing the plug. If the plug should still fail to fit, contact your electrician to replace your obsolete outlet. Do not defeat the safety purpose of the polarized plug.
- 13) Power-Cord Protection** — Power-supply cords should be routed so that they are not likely to be walked on or pinched by items placed upon or against them, paying particular attention to cords at plugs, convenience receptacles, and the point where they exit from the product.
- 14) Outdoor Antenna Grounding** — If an outside antenna or cable system is connected to the product, be sure the antenna or cable system is grounded so as to provide some protection against voltage surges and built-up static charges. Article 810 of the National Electrical Code, ANSI/NFPA 70, provides information with regard to proper grounding of the mast and supporting structure, grounding of the lead-in wire to an antenna discharge unit, size of grounding conductors, location of antenna-discharge unit, connection to grounding electrodes, and requirements for the grounding electrode.

"Note to CATV system installer:

This reminder is provided to call the CATV system installer's attention to Section 820-40 of the NEC which provides guidelines for proper grounding and, in particular, specifies that the cable ground shall be connected to the grounding system of the building, as close to the point of cable entry as practical.

Example of Antenna Grounding as per National Electrical Code, ANSI/NFPA 70

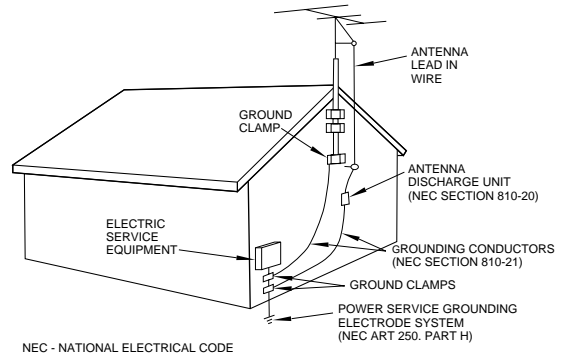

- 15) Lightning** — For added protection for this product during a lightning storm, or when it is left unattended and unused for long periods of time, unplug it from the wall outlet and disconnect the antenna or cable system. This will prevent damage to the product due to lightning and power-line surges.
- 16) Power Lines** — An outside antenna system should not be located in the vicinity of overhead power lines or other electric light or power circuits, or where it can fall into such power lines or circuits. When installing an outside antenna system, extreme care should be taken to keep from touching such power lines or circuits as contact with them might be fatal.
- 17) Overloading** — Do not overload wall outlets, extension cords, or integral convenience receptacles as this can result in risk of fire or electric shock.
- 18) Object and Liquid Entry** — Never push objects of any kind into this product through openings as they may touch dangerous voltage points or short-out parts that could result in a fire or electric shock. Never spill liquid of any kind on the product.
- 19) Servicing** — Do not attempt to service this product yourself as opening or removing covers may expose you to dangerous voltage or other hazards. Refer all servicing to qualified service personnel.
- 20) Damage Requiring Service** — Unplug this product from the wall outlet and refer servicing to qualified service personnel under the following conditions:
 - a) when the power-supply cord or plug is damaged.
 - b) if liquid has been spilled, or objects have fallen into the product.
 - c) if the product has been exposed to rain or water.
 - d) if the product does not operate normally by following the operating instructions. Adjust only those controls that are covered by the operating instructions as an improper adjustment of other controls may result in damage and will often require extensive work by a qualified technician to restore the product to its normal operation.
 - e) if the product has been dropped or damaged in any way.
 - f) when the product exhibits a distinct change in performance — this indicates a need for service.
- 21) Replacement Parts** — When replacement parts are required, be sure the service technician has used replacement parts specified by the manufacturer or have the same characteristics as the original part. Unauthorized substitutions may result in fire, electric shock, or other hazards.
- 22) Safety Check** — Upon completion of any service or repairs to this product, ask the service technician to perform safety checks to determine that the product is in proper operating condition.
- 23) Wall or Ceiling Mounting** — The product should be mounted to a wall or ceiling only as recommended by the manufacturer.
- 24) Heat** — The product should be situated away from heat sources such as radiators, heat registers, stoves, or other products (including amplifiers) that produce heat.

1 –Introduction to the DA-98

1.1 Unpacking	1-1
1.2 Features	1-1
1.3 Using this manual	1-2
1.4 Precautions and recommendations	1-2
1.4.1 Clock source in a digital studio	1-2
1.4.2 Confidence replay	1-2
1.4.3 Environmental conditions	1-3
1.4.4 Installing the DA-98	1-3
1.4.5 Electrical considerations	1-3
1.4.6 Condensation	1-3
1.5 Recommended tapes	1-4
1.5.1 Tape brands	1-4
1.5.2 Available recording and playback time	1-5

2 –Front Panel controls

[1] Power switch	2-1
[2] Tape counter and status indicators	2-1
[3] Tape loading slot	2-1
[4] EJECT key	2-1
[5] Display screen	2-1
[6] FORMAT/Fs indicators and switch	2-1
[7] REF LEVEL (reference level indicators)	2-1
[8] Peak meters	2-1
[9] RHSL (F 1) key and indicator	2-2
[10] AUTO PUNCH (F 2) key and indicator	2-2
[11] CLEAR (F 3) key	2-2
[12] AUTO PLAY (F 4) key and indicator	2-2
[13] MEMO 1 (F 5)	2-2
[14] MEMO 2 (+/-)	2-2
[15] DIGITAL IN switch and indicator	2-2
[16] CHASE switch and indicator	2-2
[17] CONFIDENCE MODE switch and indicator	2-2
[18] ALL INPUT (F 6) key and indicator	2-2
[19] AUTO MON (F 7) key and indicator	2-2
[20] SHTL MON (F 8) key and indicator	2-3
[21] REPEAT (F 9) key and indicator	2-3
[22] LOC 1 (F 10) key	2-3
[23] LOC 2 (PRESET) key	2-3
[24] SHIFT key and indicator	2-3
[25] CURSOR keys	2-3
[26] SHUTTLE switch, indicator and control	2-3
[27] ENTER and ESCAPE keys	2-3
[28] REC FUNCTION switches and indicators	2-3
[29] INPUT MONITOR switches and indicators	2-3
[30] CLOCK switch and indicators	2-3
[31] TC REC switch and indicator	2-4
[32] REW key	2-4
[33] F FWD key	2-4
[34] STOP key	2-4
[35] PLAY key	2-4
[36] RECORD key	2-4

3 –Rear Panel connectors

[37] TIME CODE (IN and OUT)	3-1
[38] VIDEO (IN/THRU)	3-1
[39] WORD SYNC (IN/OUT/THRU)	3-1
[40] RS-422	3-1
[41] MIDI IN/OUT/THRU	3-1
[42] CONTROL I/O	3-1
[43] REMOTE IN/SYNC IN	3-1
[44] SYNC OUT	3-1
[45] TDIF-1 (DIGITAL I/O)	3-1

[46] METER UNIT (MU-8824)	3-1
[47] ANALOG INPUT	3-1
[48] ANALOG OUTPUT	3-1
[49] ~ IN	3-1

4 –Connections

4.1 Audio connections	4-1
4.1.1 Analog audio connections	4-1
4.1.2 Digital audio connections	4-1
4.2 Synchronization connections	4-1
4.2.1 Analog timecode connections	4-1
4.2.2 Video connections	4-2
4.2.3 Word clock connections	4-2
4.3 Control connections	4-2
4.3.1 RS-422 connector	4-2
4.3.2 MIDI connectors (IN , OUT and THRU)	4-2
4.3.3 Parallel control	4-3
4.4 Connection to other TASCAM units	4-3
4.4.1 Multiple DTRS units	4-3
4.4.2 "Indirect" word sync	4-3
4.4.3 Meter unit (MU-8824)	4-3

5 –Menu operations

5.1 The menus	5-1
5.1.1 Navigation around the menu system	5-1
5.1.2 Using the ENTER key	5-1
5.1.3 The ESCAPE key	5-1
5.1.4 Editing values	5-1
5.1.5 Resetting a menu value	5-2
5.1.6 Changing menu values fast	5-2
5.1.7 Blanking the screen display	5-2
5.2 Function key modes	5-2
5.2.1 The SHIFT key and function keys	5-3
5.2.2 Using the function keys as number keys	5-3
5.3 Assigning menus to function keys	5-4
5.3.1 To assign a menu screen to a key	5-4
5.3.2 Recalling an assigned menu function	5-4

6 –Basic operations

6.1 Formatting a tape	6-1
6.1.1 Aborting the format process	6-1
6.1.2 Recording while formatting	6-2
6.2 Recording the first tracks	6-2
6.3 Preparing to record	6-2
6.3.1 Write-protecting cassettes	6-2
6.3.2 Recording the basic tracks (i)	6-2
6.3.3 Recording the basic tracks (ii)	6-3
6.3.4 Replaying the first tracks	6-3
6.4 Overdubbing	6-3
6.5 Track bouncing	6-3
6.6 Punch-in and punch-out	6-3
6.6.1 Automatic punch point setting	6-4
6.6.2 Setting punch points "on the fly"	6-4
6.6.3 Setting punch points using the menus	6-5
6.6.4 Editing the pre-roll and post-roll times	6-5
6.6.5 Rehearsing the punch-in	6-6
6.6.6 Interrupting a rehearsal or punch recording	6-6
6.6.7 Recording the punch-in	6-6
6.6.8 Replaying the punched material	6-7
6.6.9 Exiting punch-in mode	6-7

Table of Contents

7 –Monitoring modes

7.1 Monitoring controls	7-1
7.1.1 ALL INPUT [18] and INPUT MONITOR [29]	7-1
7.1.2 AUTO MON	7-1
7.1.3 Shuttle monitoring	7-2
7.2 Confidence mode	7-2
7.2.1 Arming tracks in pairs.....	7-3
7.2.2 Using confidence mode	7-3

8 –Advanced operations

8.1 Autolocation.....	8-1
8.1.1 Setting MEMO 1 and MEMO 2 “on the fly”	8-1
8.1.2 Checking, editing and manually entering MEMO 1 and MEMO 2	8-1
8.1.3 Setting the location pre-roll time	8-1
8.1.4 Moving to MEMO 1 and MEMO 2	8-2
8.2 Function key location memories.....	8-2
8.2.1 Storing a function key location memory	8-2
8.2.2 Editing function key memories	8-2
8.2.3 Locating to a function key memory	8-3
8.2.4 Location and playback	8-3
8.2.5 Repeat function	8-3
8.2.6 To start repeat play	8-3
8.3 Track delay	8-4
8.3.1 To set the track delay:.....	8-4
8.4 Crossfade times	8-4
8.5 Vari speed (pitch control)	8-5
8.5.1 To set a non-standard speed	8-5
8.5.2 Resetting the speed to standard	8-5
8.6 Shuttle operations	8-5
8.6.1 Shuttle monitoring	8-6
8.6.2 Shuttle muting.....	8-6
8.7 Reference levels	8-6
8.8 Meter modes.....	8-7
8.8.1 Peak hold time.....	8-7
8.8.2 Meter ballistics	8-7
8.9 Sine oscillator	8-7
8.9.1 Recording the oscillator	8-7
8.10 Digital recording	8-8
8.10.1 Changing between digital and analog inputs	8-8
8.10.2 Selecting word length	8-8
8.11 Routing digital inputs.....	8-8
8.11.1 Track Copy (channel-to-track routing).....	8-9
8.12 REC MUTE (recording silence).....	8-9
8.13 Dither	8-9
8.13.1 Selecting dither settings.....	8-10
8.14 Setting the power-on message.....	8-10

9 –Synchronization with other DTRS units

9.1 Synchronization connections.....	9-1
9.2 Machine ID and master/slave settings....	9-1
9.2.1 Differences between DTRS models	9-1
9.2.2 Setting machine ID	9-2
9.2.3 Master/slave settings (CHASE mode).....	9-2
9.3 Machine offset.....	9-2
9.3.1 Setting machine offset	9-2
9.3.2 Cancelling machine offset	9-3
9.3.3 Setting machine offset “on the fly”.....	9-3
9.3.4 An example of setting offsets	9-3
9.4 Digital dubbing.....	9-4

9.4.1 Synchronized formatting	9-5
9.4.2 Recording while formatting	9-5
9.5 Error messages.....	9-5

10 –Operations related to timecode

10.1 ABS and SMPTE/EBU timecode	10-1
10.1.1 ABS time.....	10-1
10.1.2 Tape timecode	10-1
10.1.3 Selecting TC or ABS timing	10-1
10.1.4 Location point settings.....	10-2
10.2 Tape timecode mode	10-2
10.2.1 TcTrack setting	10-2
10.2.2 ABS setting	10-2
10.2.3 ABS-Ofs setting	10-2
10.2.4 ABS-13 and ABS-23 settings	10-3
10.2.5 Checking tape TC	10-3
10.3 Selecting the frame rate	10-4
10.3.1 Pull up and pull down (Fs shift).....	10-4
10.4 Timecode input and output.....	10-4
10.4.1 Timecode input	10-4
10.4.2 Timecode output	10-5
10.4.3 Timecode output format.....	10-5
10.4.4 Timecode output timing	10-5
10.4.5 Using MIDI Time Code (MTC)	10-6
10.5 Recording timecode	10-6
10.5.1 Selecting the timecode source	10-6
10.5.2 Recording timecode using the generator	10-6
10.5.3 Synthesizing timecode from ABS timing	10-8
10.5.4 Assembling timecode.....	10-8
10.5.5 External timecode sources	10-8
10.5.6 Recording timecode from external sources ..	10-9
10.5.7 Checking external timecode	10-10
10.6 Video resolution.....	10-10
10.7 Chasing to timecode.....	10-10
10.7.1 Machine ID and timecode	10-10
10.7.2 Setting timecode offset.....	10-11
10.7.3 Setting timecode offset from the menu	10-11
10.7.4 Cancelling timecode offset	10-11
10.7.5 Setting timecode offset on-the-fly.....	10-11
10.7.6 Park position	10-12
10.7.7 Automatic park position setting	10-12
10.7.8 Absolute and relative difference	10-12
10.7.9 Rechasing timecode.....	10-13
10.7.10 Bypassing timecode errors.....	10-13
10.7.11 Individual recording while chasing timecode	10-14

11 –External control

11.0.1 Selecting the control source (protocol).....	11-1
11.1 Use with 9-pin external control.....	11-1
11.1.1 Video clocking	11-1
11.1.2 Emulation.....	11-1
11.1.3 Record delay	11-1
11.1.4 Cue-up tally	11-2
11.1.5 Fast wind speed	11-2
11.1.6 Track mapping	11-3
11.1.7 Timecode track mapping.....	11-3
11.1.8 Remote track arming	11-4
11.2 Bus protocol.....	11-4
11.2.1 Assigning a MIDI and Bus ID to the DA-98...	11-4
11.3 MIDI Machine Control	11-4
11.3.1 MMC commands and the DA-98	11-4

12 –Menu and parameter reference	
12.1 Menu groups	12-1
12.1.1 Menu group 0	12-1
12.1.2 Menu group 1	12-2
12.1.3 Menu group 2	12-2
12.1.4 Menu group 3	12-3
12.1.5 Menu group 4	12-3
12.1.6 Menu group 5	12-4
12.1.7 Menu group 6	12-5
12.1.8 Menu group 7	12-5
12.1.9 Menu group 8	12-6
12.1.10 Menu group 9.....	12-6
12.1.11 Menu group E	12-7
12.1.12 Menu group F	12-7
12.2 Menu item index	12-8
13 –Example setups	
13.1 An all-DA-98 setup	13-1
13.2 Post-production work.	13-2
13.3 Project studio ('B' room)	13-4
14 –Maintenance and memory setups	
14.1 Head and transport cleaning	14-1
14.1.1 To clean the heads and transport.....	14-1
14.1.2 Checking error rates	14-2
14.1.3 Checking head time	14-2
14.1.4 Checking head search time.....	14-2
14.2 Memory backup	14-3
14.3 User setups	14-3
14.3.1 Saving user setups.....	14-3
14.3.2 Loading user setups	14-3
14.3.3 Resetting the memory.....	14-4
14.4 Checking version numbers	14-4
14.4.1 Software upgrades	14-4
15 –Options, specifications and reference	
15.1 Options for the DA-98	15-1
15.1.1 RM-98 Rack Mount Adaptor	15-1
15.1.2 Remote control (RC-848)	15-1
15.1.3 Meter unit (MU-8824).....	15-1
15.1.4 Digital audio convertors	15-2
15.1.5 Cables.....	15-2
15.1.6 CONTROL I/O connector pinout.....	15-2
15.2 Specifications	15-3
15.2.1 Physical specifications	15-3
15.2.2 Power specifications	15-3
15.2.3 Digital recording characteristics	15-3
15.2.4 Tape recorder section	15-3
15.2.5 Tape transport	15-4
15.2.6 Inputs and outputs	15-4
15.2.7 Audio specifications	15-4
15.2.8 9-pin (RS-422), MIDI, synchronizer specifications	15-4
15.3 MMC Bit Map Array	15-6
15.4 MIDI Implementation Chart	15-8

Table of Contents

1 – Introduction to the DA-98

The TASCAM DA-98 is a digital audio multitrack recorder designed for use in a variety of applications, including video post-production and audio multitrack work.

It records 8 tracks of full-quality digital audio on standard Hi8 video cassettes using a specially-designed transport and head mechanism. Using this medium, up to 108 minutes of continuous recording is possible on a single NTSC “120” tape.

Recording is carried out at a full 16 bits of resolution, and digital data may be input at 16, 20 or 24 bits of resolution. Analog signals are converted to digital data using 64 times oversampling delta-sigma techniques.

The DA-98 builds on the foundations laid by the TASCAM DA-88 and DA-38 digital multitrack recorders, and retains compatibility with them. Tapes recorded on one of the DA series can be replayed and overdubbed on any other machine in the series, or any DTRS¹ machine.

1.1 Unpacking

The box contains the following.

- DA-98 Digital Multitrack Recorder (x 1)
- Accessories:
 - Rackmount screw kit (x 1)
 - AC power cord, 2 m (6 ft) long (x 1)
 - This manual (x 1)
- Warranty card (x 1)

1.2 Features

Other key features of the DA-98 include:

- TASCAM-exclusive high-performance/high wear resistive rotary 4-head mechanism with TASCAM original track layout (DTRS standard)
- Use of standard, low-cost media with long recording and playback times

- 16-bit linear quantization at either 44.1 kHz or 48 kHz provides CD-quality sound or better
- Fast, frame-accurate tape location and positioning; end-to-end winding for a “120” tape is around 80 seconds
- Direct digital synchronization of up to 16 DTRS recorders (128 tracks) without the use of any external synchronizer or controller
- Direct digital dubbing between DTRS units
- Track Copy function acts as an internal digital patchbay, allowing input-to-track assignment without the use of external equipment
- Balanced +4dBu analog inputs and outputs carried on a convenient compact D-sub connector
- Selectable nominal analog I/O levels to conform to SMPTE, EBU, etc. standards
- 15-segment peak meters with user-selectable fall ballistics and variable hold time (including continuous peak hold)
- Integral digital sine oscillator, providing signals at 440Hz for tuning and 1kHz for lineup purposes
- Digital input and output on a single convenient compact D-sub connector (TDIF-1 format)
- Settings carried out through a menu hierarchy using a 20-character x 4-line LCD display with cursor keys and an ENTER/ESCAPE system
- The 10 most commonly-used functions can be assigned to “soft keys” for easy recall
- Full SMPTE/EBU timecode synchronization, including on-board timecode generator
- MIDI Time Code and MIDI Machine Control
- Confidence replay mode, allowing off-tape monitoring while recording is in progress
- Input monitor mode allows channel-by-channel source monitoring, regardless of tape transport status
- Three user setup memory banks for storing setup profiles
- Simplified source/tape monitoring functions with automatic switching
- Auto punch-in and punch-out with rehearsal mode
- 2-point full function autolocator with A–B repeat function, and 10 “soft key” location memories
- Variable speed recording and playback (up to 6.0% in 0.1% steps)

¹ DTRS is a trademark of TEAC Corporation

- Shuttle mode enables “rock and roll” audio positioning of key locations

1.3 Using this manual

We suggest that you take the trouble to read this manual through at least once before starting to use the DA-98. In this way, you will find out where to turn when you need answers.

We suggest that you make a special note of the section 1.4, “Precautions and recommendations” as these contain some information which is unique to the DA-98.

We also suggest that you also read 5, “Menu operations”, as this will help you when you come to perform basic operations.

When referring to a control or a connector on the DA-98, the name of the control or connector will be written in bold type, and will often be followed by a number in brackets, as in the example below:

Holding down the **PLAY** [35] and pressing the **RECORD** [36] key will start the recording process.

The numbers refer to the front and rear panel illustrations and description in 2, “Front Panel controls” and 3, “Rear Panel connectors”.

When referring to a word or phrase which appears on the LCD display screen, the word or phrase will be written as follows:

Move the cursor to **LOC** .

Sometimes the tape counter is used to display a message. This will be shown as follows:

The tape counter will show **--LoAd--**.

NOTE

Recording is an art as well as a science. A successful recording is often judged primarily on the quality of sound as art, and we obviously cannot guarantee that. A company that makes paint and brushes for artists cannot say that the paintings made with their products will be critically well-received. TASCAM can make no guarantee that the DA-98 *by itself* will assure the quality of the recordings you make. Your skill as a technician and your abilities as an artist will be significant factors in the results you achieve.

1.4 Precautions and recommendations

As with any precision piece of electronic equipment, common-sense precautions apply with the DA-98.

However, there are a few extra precautions which apply to the DA-98, and we suggest that you make a note of these, to prolong the useful life of the DA-98.

1.4.1 Clock source in a digital studio

The DA-98 can be used in a variety of situations, and with a variety of equipment, either digital or analog.

If you are working with more than one digital audio unit in your setup, you should note that all units must be driven by the same central clock source (“word clock” or “word sync”).

If different word clock sources are used throughout the setup, it is actually possible to damage speakers, etc. because of mismatches.

The DA-98 can be designated as the word clock master for your studio, or can be slaved to external word clocks, using a convenient front-panel switch and standard BNC connectors.

Even though AES/EBU stereo digital audio signals are self-clocking, any AES/EBU format signals converted and fed to or from the DA-98 must be synchronized at word level with the DA-98.

1.4.2 Confidence replay

Because the DA-98 can accept digital data and converts analog data with longer word lengths than it uses to record on tape (16-bit resolution), monitoring the input source during recording will not necessarily provide a completely accurate representation of what is recorded on tape.

The DA-98 provides a dither setting (see 8.13.1, “Selecting dither settings”) which provides improved total harmonic distortion figures. Since the dither is applied prior to recording, again, monitoring the input source will not allow you to hear the effect of the dithering process.

Accordingly, the DA-98 provides a confidence mode, allowing you to monitor off-tape as record-

ing progresses. Since this monitoring is not synchronized exactly with the source inputs, gapless punch-in and punch-out is not possible in confidence mode. For full details of confidence monitoring, together with other monitoring modes available on the DA-98, see 7, “Monitoring modes”.

1.4.3 Environmental conditions

The DA-98 can be operated in most environments, but we suggest that you keep the environmental conditions within the following limits:

Ambient temperature between 5° and 35° C (41° and 95° F).

Relative humidity should be between 30% and 80% non-condensing

There should be no strong magnetic fields (speakers, etc.) near the DA-98.

Avoid spraying polish, insecticides, etc. near the DA-98.

WARNING

If you need to clean the DA-98, use a soft cloth, moistened if necessary with a little detergent and water. Do not use abrasive cleaners or solvents such as alcohol or thinner.

Avoid subjecting the DA-98 to jolts, sudden shocks, etc.

WARNING

If you have to return the unit for service or repair, use the original packing materials if possible. If the unit is to be transported to a recording location, etc., use a suitable transport case with sufficient shock protection.

TASCAM does not accept responsibility for damage resulting from neglect or accident.

1.4.4 Installing the DA-98

The DA-98 may be installed in a standard 19” rack, occupying 4U of space. Since the DA-98 is quite heavy (around 11kg – 24lb), your rack should be strong and stable to take the weight of the DA-98.

Optional rack mount adaptor handles (RM-98) are available. For details, see 15.1.1, “RM-98 Rack Mount Adaptor”.

The DA-98 should be mounted with the front panel vertical.

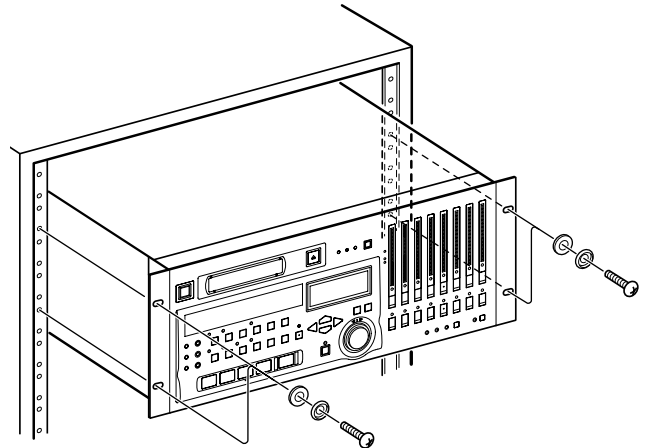

1.4.5 Electrical considerations

Make sure that your local power supply matches the voltage requirements marked on the rear panel of the DA-98.

If you are in any doubt concerning the local power supply, consult an electrician.

Avoid extreme voltage fluctuations. If necessary, use an input voltage regulator to smooth the power supplied to the DA-98.

Do not open the unit to clean inside, or to perform any internal adjustments. You should not attempt any cleaning or other maintenance procedures which are not described in this manual.

You may need to clean the heads occasionally. The procedure for doing this, and for checking tape error rates, etc., is given in 14, “Maintenance and memory setups”.

1.4.6 Condensation

If you use the DA-98 in a warm place after moving it from a cold place (for instance, recording on location), or if there has been a sudden change in temperature, condensation may occur within the tape mechanism, with a risk of possible damage to the unit.

Section 1 – Introduction to the DA-98

If condensation does occur, you will not be able to operate the DA-98 controls, and you will see the following message on the display:

```
WARNING !  
  
Condensation on drum
```

If you see the above message, press the **ESCAPE** key to remove the message, leave the DA-98 switched on for one or two hours, then switch it off and on again before starting recording.

If you are going to use the DA-98 in a location where you think condensation is likely to occur, move the DA-98 into the warmer location about one or two hours before recording is due to start, and leave it switched on. Turn the DA-98 off and then on again before starting recording.

1.5 Recommended tapes

The DA-98 is designed for use with Hi8 video cassettes. You cannot use any other kind of tape with the DA-98.

There are two basic types of Hi8 tape: MP and ME. Each has its own particular characteristics and merits:

- MP tapes are manufactured using a daubed magnetic particle deposit process and exhibit a level of performance which is more than acceptable. They have a durability which allows them to be used as work tapes in studio and post-production environments.
- ME tapes have their magnetic layer produced through a metal evaporation process. Generally speaking, though these tapes have a high performance level, they are not as robust as MP tapes (see above) and should be used for live recording and archival purposes, rather than as work tapes.

TASCAM does not endorse any specific tape or tape manufacturer. TASCAM has licensed the use of the DTRS logo (**DTRS**™) to tape manufacturers, provided their tape meets the specifications required by DTRS tape recorders. However, the use of the DTRS logo on the tape packaging does not imply any endorsement of the tape by TAS-

CAM. It is possible that the characteristics and sensitivities of tapes may be changed by the manufacturers without notice. The brands and model numbers of tapes listed below may not always meet the specifications required by DTRS systems for optimum performance. TASCAM assumes no responsibility for problems resulting from changes made by a manufacturer to the materials or specifications of its tape products.

The electrical characteristics of DTRS recorders are adjusted and set using Sony Hi8 tape parameters (MP and ME) prior to shipment.

1.5.1 Tape brands

The following brands and models of tape can be used with the DA-98. As mentioned above, this list does not constitute any endorsement by TASCAM of these products, nor is it a guarantee that tapes bearing this brand and model name will continue to give optimum performance.

Maker	MP	ME
SONY	DARS-MP	E6-HME
	P6-HMP	E5-HME
	P6-HMPX	E6-HMEAD
	P5-HMP	E5-HMEAD
	P5-HMPX	E6-HMEX
		E5-HMEX
AMPEX	DA8 MP	
BASF	DA MP	
TDK	Hi8 MP	Hi8 ME Position
	Hi8 MP Position	Hi8 ME Pro
FUJI	HI P6- DS N	
	HI P5- DS N	
	M221MP P6-	
	M221 MP P5-	
MAXELL	P6- XR-M	E6- XD-MN
	P5- XR	E5- XD

The electronics of DTRS recorders are designed to operate within specific parameters. The use of a tape with sensitivity higher or lower than that of

tapes for which the DTRS recorder was originally designed may cause an error in functionality or prevent the user from getting optimum performance from the tape. Always use the shortest possible tape for a given project. Do not attempt to use 150-minute or longer tapes in DTRS machines, as the machine will detect the thickness of tape and automatically eject any tape thinner than recommended.

Never attempt to use a tape with the DA-98 that has previously been used in video equipment.

WARNING

You cannot cut and splice DTRS 8mm tapes for editing purposes. Using a spliced tape in the DA-98 will invariably result in serious damage to the heads, requiring replacement. All editing must be done digitally.

1.5.2 Available recording and playback time

Depending on whether the tape has been purchased for use with an NTSC (P6/E6) or a PAL/SECAM (P5/E5) television system, the same length of tape (as far as video length is concerned) will provide different times for audio work, as shown below, due to different frame rates between television systems. The indication P6/E6 or P5/E5 will be printed on the tape package:

Time on tape label	P6/E6 (NTSC tape)	P5/E5 (PAL/SECAM tape)
20	18	25
30	27	37
45	40	56
60	54	75
90	81	113
120	108	–

2 – Front Panel controls

[1] Power switch

Turns the power to the DA98 on and off. When the DA-98 is turned off, settings will be retained in memory (see 14.2, “Memory backup”).

[2] Tape counter and status indicators

The tape counter gives the time in hours, minutes, seconds and frames.

The status indicators show the current status of various DA-98 functions. The legends of these indicators are abbreviated for reasons of space. Here is a list of their full meanings, together with the pages on which the functions are more fully described:

Legend	Meaning	Page
PB CONDITION	Playback condition	14-1
ABS	Absolute tape time is being used as the time reference	10-1
REC INHI	Recording is inhibited (the cassette’s write-protect tab is set)	6-2
TC	Timecode time is being used as the time reference	10-1
OFFSET	Machine offset is in operation	9-2
TRACK COPY	Shows that the DA-98 is in TRACK copy mode	8-9
PULL UP/DN	Shows pull up or down for drop-frame synchronization	10-4
TAPE TC	Lights when the DA-98 is reading timecode from the tape	10-2
TC GEN	Lights when the internal timecode generator is generating	10-6
DELAY	Lights when one or more of the tracks is delayed	8-4
VARI SPEED	Lights when the DA-98’s vari speed function is enabled	8-5
SHTL MUTE	Shows that the shuttle mute function is in operation	8-6
EXT TC	Lights when the DA-98 is receiving external timecode	10-2

[3] Tape loading slot

Only use Hi8 ME or MP tapes as specified on page 1-4. The DA-98 will automatically eject all other tapes.

WARNING

Do not use a tape which has been used for recording video. Always use either new tapes or tapes which have been used in a DTRS recorder.

[4] EJECT key

Ejects any loaded cassette. A cassette can only be ejected when the transport is stopped.

[5] Display screen

This 20-character by 4-line LCD screen shows the menus and the parameters that can be set in the menus.

[6] FORMAT/Fs indicators and switch

The **FORMAT** indicator shows that a tape is being formatted. The **44.1KHz** and **48KHz** indicators show the sampling frequency currently in use.

The **FORMAT/Fs** switch controls the formatting of tapes and allows selection of the sampling frequency used for recording (see 6.1, “Formatting a tape” for full details).

[7] REF LEVEL (reference level indicators)

These LEDs are used to indicate three standard reference levels: –16dBFS, –18dBFS and –20dBFS. For full details of this, see 8.7, “Reference levels”.

[8] Peak meters

These 15-segment peak meters show the input level or the recorded signal level, depending on the monitoring mode currently in operation (see 7, “Monitoring modes”).

NOTE

When using digital recording equipment, there is no headroom above the 0dB mark and no tape saturation is possible. Any signal which causes the “OVER” segment to light will cause audible distortion. For this reason you should take care not to let recording levels exceed this level.

Section 2 – Front Panel controls

The ballistics and peak hold times are selectable (see 8.8, “Meter modes”).

[9] RHSL (F 1) key and indicator

This key and indicator allow selection of the rehearsal mode in auto punch-in and out (see 6.6, “Punch-in and punch-out”).

When the **SHIFT** key [24] is pressed, this key becomes a function key.

[10] AUTO PUNCH (F 2) key and indicator

This key and indicator allow automatic punch-in and punch out following rehearsal (see 6.6, “Punch-in and punch-out”).

When the **SHIFT** key [24] is pressed, this key becomes a function key.

[11] CLEAR (F 3) key

This key defeats the rehearsal and auto modes during auto punch-in and out (see 6.6, “Punch-in and punch-out”). It is also used to cancel a format operation (see 6.1, “Formatting a tape”).

When the **SHIFT** key [24] is pressed, this key becomes a function key.

[12] AUTO PLAY (F 4) key and indicator

When this key is pressed (the indicator will light), the DA-98 will automatically start playing as soon as a preset location point has been reached (see 8.2.4, “Location and playback”).

When the **SHIFT** key [24] is pressed, this key becomes a function key.

[13] MEMO 1 (F 5)

When pressed, this key stores the current tape position into a memory location point which can be accessed using the **LOC 1** key [22]. The location can be “nudged” using the menu functions (see 8.1.2, “Checking, editing and manually entering MEMO 1 and MEMO 2”).

When the **SHIFT** key [24] is pressed, this key becomes a function key.

[14] MEMO 2 (+/-)

When pressed, this key stores the current tape position into a memory location point which can be accessed using the **LOC 2** key [23]. When the

function keys are used as number keys, this key is used as a “sign-change” key.

[15] DIGITAL IN switch and indicator

This switch controls the input to the DA-98. When on (indicator lights), the input is through the **DIGITAL I/O (TDIF-1)** connector on the rear panel, otherwise it is through the **ANALOG INPUT** connector.

[16] CHASE switch and indicator

The **CHASE** switch controls whether the DA-98’s transport is to “chase” a master machine (indicator is lit when chasing or flashing when preparing to chase) or to operate independently. The chase mode may be either timecode or ABS based (see 10.1, “ABS and SMPTE/EBU timecode”).

[17] CONFIDENCE MODE switch and indicator

The DA-98 features a confidence replay mode which allows off-tape monitoring. This switch and its associated indicator allow selection and viewing of the status of this monitoring mode.

For a full explanation of confidence monitoring, see 7.2, “Confidence mode”.

[18] ALL INPUT (F 6) key and indicator

When this key is pressed, the indicator will light, and, regardless of the transport mode, all outputs will be switched to the signals derived from the inputs. This is primarily for alignment purposes, and is equivalent to pressing all the **INPUT MONITOR** switches ([29]) together.

For a full treatment of monitoring modes on the DA-98, see 7, “Monitoring modes”

When the **SHIFT** key [24] is pressed, this key becomes a function key.

[19] AUTO MON (F 7) key and indicator

When this key is pressed (the indicator will light), the monitoring system of the DA-98 automatically changes between input and off-tape monitoring, depending on the transport mode.

For a full treatment of monitoring modes on the DA-98, see 7, “Monitoring modes”

When the **SHIFT** key [24] is pressed, this key becomes a function key.

[20] SHTL MON (F 8) key and indicator

When this key is pressed, shuttle monitoring is enabled (see 7.1.3, “Shuttle monitoring”).

When the **SHIFT** key [24] is pressed, this key becomes a function key.

[21] REPEAT (F 9) key and indicator

When this key is pressed, playback is repeated between the two memory locations set by [13] and [14] (see 8.2.5, “Repeat function” for details).

When the **SHIFT** key [24] is pressed, this key becomes a function key.

[22] LOC 1 (F 10) key

This key locates the tape to the position set by **MEMO 1** [13].

When the **SHIFT** key [24] is pressed, this key becomes a function key.

[23] LOC 2 (PRESET) key

This key locates the tape to the position set by **MEMO 2** [14].



When the **SHIFT** key [24] is pressed, this key allows the assignment of the function keys ([9] through [13], and [18] through [22]) (see 5.3, “Assigning menus to function keys”).

[24] SHIFT key and indicator

When this latching key is pressed (the indicator will flash), keys [9] through [13] and [18] through [22] become function keys, and key [23] takes on a new function as a **PRESET** key (see 5.3, “Assigning menus to function keys”).

[25] CURSOR keys

These keys are used to navigate the cursor through the menus controlling the DA-98 functions.

When a menu has been selected, the **UP** and **DOWN** keys ( and ) are used to set the values or select the choices within the menu).

See page 5-1 for details of how to use these keys in menu operations.

[26] SHUTTLE switch, indicator and control

When the **SHUTTLE** key is pressed, the indicator will light. The **SHUTTLE** control will then be active. Turning the control to the right provides

forward cueing and turning it to the left provides reverse cueing, similar to “rock and roll” on open-reel tape decks.

For details, see 8.6, “Shuttle operations”.

[27] ENTER and ESCAPE keys

These keys are used in conjunction with the cursor keys [25] to go “up and down” the menu hierarchy.

See page 5-1 for details of how to use these keys in menu operations.

[28] REC FUNCTION switches and indicators

These eight switches and indicators allow the setting and viewing of the record status on a track-by-track basis.

When one of these switches is pressed, the appropriate indicator will flash, the track is “armed”, and going into record mode will start recording on that track. When recording is being carried out on a track, the track’s indicator will light steadily.

[29] INPUT MONITOR switches and indicators

These switches allow the monitoring of inputs to tracks on a track-by-track basis, irrespective of the current transport status. The appropriate indicator(s) will light when monitoring track input(s) using these switches.

Note that the function of these switches is connected with the **ALL INPUT** key [18] (page 7-1).

[30] CLOCK switch and indicators

This switch and these indicators allow you to set and view the system clock. There are three options:

Setting	Meaning
INT	The DA-98 will provide its own clock reference
WORD	The clock will be synchronized to the signal received at the WORD SYNC IN connector
VIDEO	The clock will be synchronized to the signal received at the VIDEO IN connector

For full details of external synchronization, see 10, “Operations related to timecode”.

Section 2 – Front Panel controls

[31] TC REC switch and indicator

This switch is used when you wish to record timecode (either internally generated or from an external source) on a dedicated subcode track of the DA-98. No audio track is needed to record timecode. For full details of timecode operation, see 10, “Operations related to timecode”.

NOTE

It is not necessary to use timecode if two DTRS units (e.g. DA-88, DA-38 or DA-98 machines) are to be operated together. The **SYNC** connections will ensure synchronization between machines (see 9.2, “Machine ID and master/slave settings”).

If the DA-98 is in play mode, and the **REC** key is pressed, recording will start immediately on any “armed” tracks.

The **RECORD** key also is used to set punch-in points during auto punch-in/out operations (see 6.6, “Punch-in and punch-out”).

[32] REW key

Rewinds the tape at high speed.

If this key is pressed during recording, recording will stop and the tape will rewind.

[33] F FWD key

Winds the tape forward at high speed.

If this key is pressed during recording, recording will stop and the tape will wind forward.

NOTE

When either **REW** or **F FWD** is pressed for the first time after powering up, or loading a tape, the unit first configures itself for the reel hub diameter of the tape in use, during which the tape advances at low speeds. This takes several seconds. Thereafter, the transport momentarily goes into stop mode before the tape starts fast-winding.

[34] STOP key

Cancels any current tape transport mode, and stops the tape.

[35] PLAY key

Starts playing the tape. If this key pressed while recording is in progress, the DA-98 drops out of record mode.

[36] RECORD key

If the **PLAY** key ([35]) is pressed while the **RECORD** key is held down, recording will start on all “armed” tracks (see 6.3, “Preparing to record”).

3 – Rear Panel connectors

This section provides a brief description of the functions of the connectors on the rear panel. For full details of cables to be used, pinouts, etc., see 4, “Connections”.

[37] TIME CODE (IN and OUT)

This pair of XLR connectors (female for **IN** and male for **OUT**) provides the timecode connections for the synchronization functions of the DA-98. See 10, “Operations related to timecode” for full details.

[38] VIDEO (IN/THRU)

The **VIDEO** BNC connectors are used to carry video frame sync signals when the DA-98 is used with video equipment. The self-terminating **THRU** connector echoes messages received at the **IN**.

See 10.6, “Video resolution” and 11.1.1, “Video clocking” for details of video sync operation.

[39] WORD SYNC (IN/OUT/THRU)

These BNC connectors are used to carry the word clock between the DA-98 and other types of digital audio equipment. The **THRU** connector is self-terminating. See 8.10, “Digital recording” for full details.

[40] RS-422

This connector is used for controlling the DA-98 using controllers or editors which conform to the Sony P2 protocol (RS-422). See 11.1, “Use with 9-pin external control” for full details of how to use this connector.

[41] MIDI IN/OUT/THRU

These connectors carry MIDI Time Code (MTC) and MMC (MIDI Machine Control) commands. See 11.3, “MIDI Machine Control” for details of how these facilities are used when synchronizing to other units.

[42] CONTROL I/O

This connector is used for control of the DA-98 by external equipment. Consult your TASCAM dealer for full details of compatibility and the use of this connector.

The pinout for this connector is given in 15.1.6, “CONTROL I/O connector pinout”.

[43] REMOTE IN/SYNC IN

This connector is used to connect another “master” DTRS unit (e.g. DA-98, DA-88 or DA-38). See 9, “Synchronization with other DTRS units” for further details.

An RC-848 remote control unit may also be connected here, but not all functions of the DA-98 are available from the remote control unit.

[44] SYNC OUT

This is used to connect another DTRS unit in the “daisy-chain” or, if this DA-98 is the last unit in the chain, to attach a termination plug.

[45] TDIF-1 (DIGITAL I/O)

This connector carries the digital signals to and from the DA-98 in TEAC Digital Interface Format (TDIF-1).

[46] METER UNIT (MU-8824)

This connector carries power and signals to drive 8 channels of the optional MU-8824 24-channel Meter Unit.

Make the connection using a TASCAM PW-88M cable.

[47] ANALOG INPUT

This connector carries 8 balanced inputs at a nominal +4dBu level. This allows convenient and reliable single-cable connection to the **GROUP** outputs of a suitably-equipped console such as the TASCAM M-1600 series.

[48] ANALOG OUTPUT

This connector carries 8 balanced outputs at a nominal +4dBu level. This allows convenient and reliable single-cable connection to the tape return inputs of a suitably-equipped console such as the TASCAM M-1600 series.

[49] ~ IN

Use the provided AC power cord to connect the DA-98 to the AC power supply through this connector.

Section 3 – Rear Panel connectors

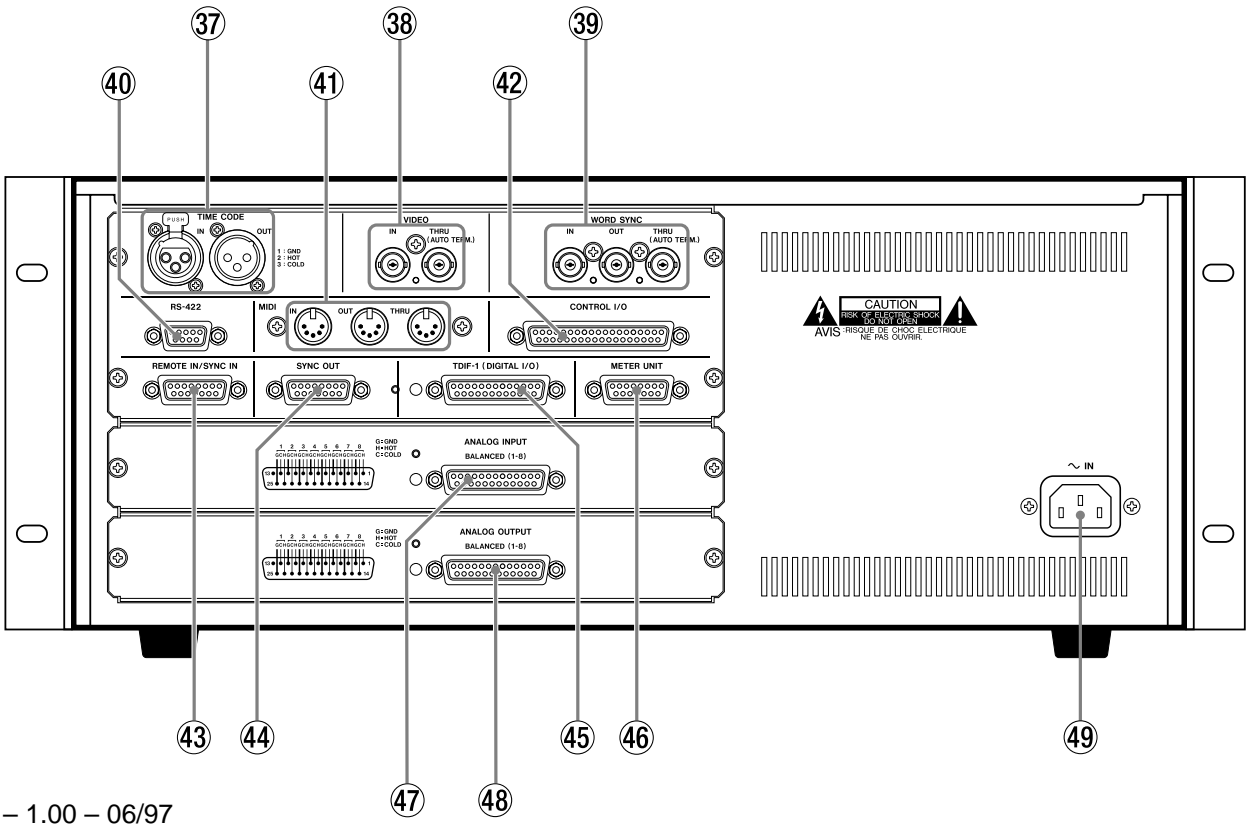
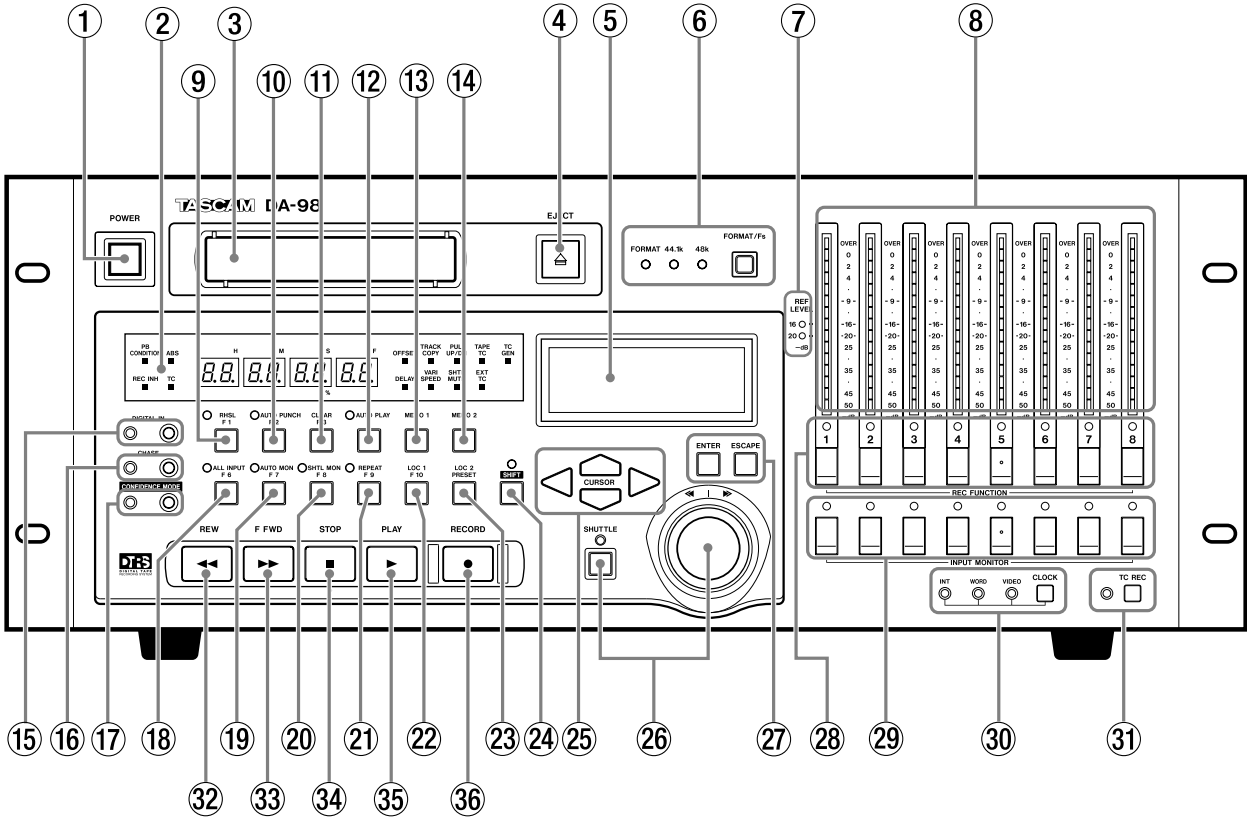

4 – Connections

This section explains how to connect other equipment to the DA-98 in a variety of situations. It is not intended as a complete reference to the use of the DA-98. See the appropriate sections for full details of how these connectors are used.

WARNINGS

- When making connections between the DA-98 and other equipment, whether audio or control, both the DA-98 and the other equipment must be turned **off**, otherwise damage may be caused to the DA-98 and/or the other equipment.
- Only use TASCAM-supplied and TASCAM-approved cables when making connections to the DA-98. Though the cables and connectors may resemble computer cables, they serve different purposes, and meet a different set of specifications. The use of cables other than TASCAM cables will at best cause the equipment to work erratically, and at worst cause damage to the equipment.
- If the use of cables other than TASCAM cables causes or results in damage, the warranty is voided.

4.1 Audio connections

Other audio equipment can be connected to the DA-98 either using analog or digital interfaces.

4.1.1 Analog audio connections

All analog audio connections to the DA-98 are made through 25-pin D-sub connectors (input signals through [47] and output signals through [48]).

This allows convenient and tidy cabling between the DA-98 and other units such as the TASCAM M-1600 series of mixing consoles.

It is not recommended that you make up your own cables—consult your TASCAM dealer for availability of suitable ready-made cables (and see 15.1.5, “Cables”). However, we recognize that every situation has its own unique features, and there are occasions when a special cable must be made.

Before starting to make the cable, we suggest you contact your TASCAM dealer for full details of cable specifications, etc.

The pinouts for both the **ANALOG OUTPUT** and **INPUT** connectors are as follows:

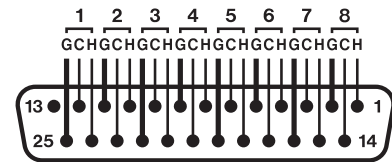

where **G**=ground, **H**=“hot” (+) and **C**=“cold” (–).

All audio inputs are balanced and are rated at a nominal +4dBu level.

The impedance of the inputs is 20kΩ and that of the outputs is 10Ω.

4.1.2 Digital audio connections

Digital audio input and output signals are carried on the same 25-pin D-sub connector [45]. The signals are in TDIF-1 format.

To carry signals between a DA-98 and another DTRS unit, use a PW-88D cable (1 meter long) or a PW-88DL cable (5 meters long). You may also use these cables to connect the DA-98 to other TDIF-1-equipped devices.

If you need to connect the DA-98 to a digital audio source using a different format, we recommend the use of the following units:

- TASCAM IF-88AE Interface Unit – converts between the TDIF-1 and AES/EBU formats (8 channels). It also provides S-PDIF format conversion facilities.
- TASCAM IF-88SD Interface Unit – converts between the TDIF-1 and SDIF-2 digital audio formats.

4.2 Synchronization connections

The DA-98 is equipped with sophisticated facilities for control and synchronization with other units. For full details of how to operate the DA-98 with other units, see 10, “Operations related to timecode”.

4.2.1 Analog timecode connections

The DA-98 can be synchronized to externally-generated timecode and is also equipped with an internal timecode generator. For full details of

Section 4 – Connections

how to use the DA-98 with timecode, see 10, “Operations related to timecode”.

The two XLR timecode connectors [37] carry balanced signals with the following polarity:

Pin # Connection

1	Ground
2	Hot
3	Cold

However, unbalanced signals may be used, with only pins 1 and 2 connected.

	IN (balanced)	OUT (balanced)
Level	0.5 V _{p-p} to 10.0V _{p-p}	2V _{p-p}
Impedance	> 10k Ω	< 100 Ω

The **TIMECODE OUT** connector either transmits internally-generated timecode or re-shaped or re-generated timecode echoed from the **TIMECODE IN** connector.

4.2.2 Video connections

This pair of BNC connectors [38] is used to provide video frame reference clocking when the DA-98 is used with video equipment.

The front panel **CLOCK** switch [30] is used to change between clock sources, and should be set to **VIDEO** when synchronizing to video sync.

Connect the **VIDEO IN** connector of the DA-98 to the **VIDEO OUT** of a video unit. This signal should be a 1 V_{p-p} composite signal.

If other equipment (such as other DTRS units) also need the video frame reference clock, the signal received at the **VIDEO IN** is echoed at the **VIDEO THRU** connector.

If the DA-98 is the last unit in the chain of video equipment, there is no need to terminate it, as this circuit is self-terminating.

For details of how the DA-98 can be synchronized to video frame information, see 11.1.1, “Video clocking”.

4.2.3 Word clock connections

This set of BNC connectors [39] is used to synchronize the DA-98 to other digital audio devices.

The front panel **CLOCK** switch (page 2-3) is used to change between clock sources, and should be set to **WORD** when synchronizing to an external word clock.

The **IN** jack should be connected to the **WORD SYNC OUT** of the digital audio device from which the DA-98 is to receive the synchronization clock.

Note the difference between the **OUT** and the **THRU** connectors. **OUT** is used to carry word clock signals generated by the DA-98, and **THRU** is used to echo the signals received at **IN**.

If the DA-98 is the last unit in the chain of video equipment, there is no need to terminate it, as this circuit is self-terminating.

Also note that if the DA-98 is connected to other DTRS units, the **WORD SYNC** jacks do not need to be connected between the DTRS units.

4.3 Control connections

4.3.1 RS-422 connector

This connector is used to connect the DA-98 to other controllers or editors which will control the DA-98 using the Sony P2 protocol, or a bus protocol, such as that used by the TASCAM ES-61.

If you are in doubt about the compatibility of such a device, please consult TASCAM or your TASCAM dealer, who will be able to advise you.

The DA-98 can emulate (through software control accessed through menu 6) a number of devices for compatibility with almost any controller. See 11.1.2, “Emulation” for details.

Full details of control using this connector are given in 11.1, “Use with 9-pin external control”.

4.3.2 MIDI connectors (IN , OUT and THRU)

These standard 5-pin DIN MIDI connectors [41] are used to carry MIDI Time Code (MTC) and MIDI Machine Control (MMC) information

between the DA-98 and other suitably-equipped units (for instance, sequencers capable of being synchronized to MTC, and capable of transmitting MMC commands).

The MIDI functions are accessed through menu group 7. See 10.4.5, “Using MIDI Time Code (MTC)” and 11.3.1, “MMC commands and the DA-98” for full details.

Note the difference between **MIDI OUT** and **MIDI THRU**. The **OUT** connector outputs signals which originate from the DA-98. The **THRU** connector echoes messages received at the **IN**.

4.3.3 Parallel control

Parallel control by and of the DA-98 is performed through the **CONTROL I/O** port [42]. See 15.1.6, “CONTROL I/O connector pinout” for details of how to connect other equipment to this port.

4.4 Connection to other TASCAM units

By a “TASCAM unit”, we mean another DA-98, a DA-88 or a DA-38 unit, or an optional remote control unit, which may also be connected in a “chain” with multiple DTRS units.

4.4.1 Multiple DTRS units

Use a TASCAM PW-88S cable when connecting other units to the **REMOTE/SYNC IN** connector [43] or to the **SYNC OUT** connector ([44]).

This synchronization cable will carry the internal synchronization code and the transport signals, etc. There is no need to make any other connections, apart from the audio connections (either digital or analog).

If more than one DTRS unit is to be used, the first unit in the chain must have its Machine ID set to “1”, (“0” in the case of DA-88s) and subsequent units must have their IDs set in order with no gaps in the numbering sequence. Note that the diagram below does not show any audio connections.

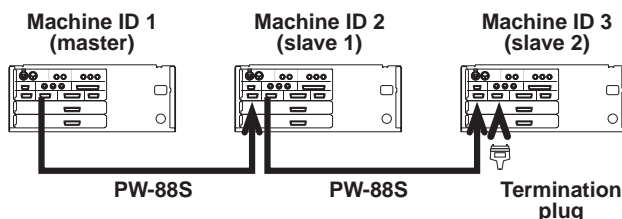

See 9.2.2, “Setting machine ID” for details of setting the Machine ID using menu group 3.

WARNINGS

The last unit in the chain must be terminated (a TASCAM termination plug must be plugged into the **SYNC OUT** of the last machine in the chain.

Once again, only use TASCAM cables for connection of equipment to and from the DA-98.

4.4.2 “Indirect” word sync

As mentioned earlier, there is usually no need to use a word clock when connecting DTRS units together. There is, however, an occasion when it is necessary to carry external word sync between DTRS units.

This is when a slave DTRS unit is recording digitally from another digital audio device:

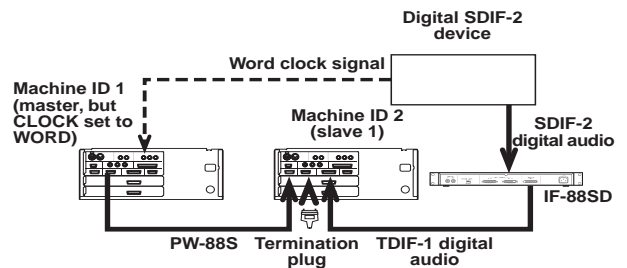

Though the slave will receive its word clock from the master unit, the master itself must receive its word clock from the other digital audio device.

In this case, the master unit will have its clock source set to **WORD**, and the slave will receive its clock from the master unit through the **SYNC IN** [43].

4.4.3 Meter unit (MU-8824)

The optional MU-8824 external meter bridge unit can be connected using a PW-88M cable from the **METER UNIT** connector [46]. You do not need to make any settings on the DA-98 when connecting the meter unit.

Section 4 – Connections

5 – Menu operations

Read this section to understand the basic principles of menu operation. This will help you find your way round the DA-98's functions easily and quickly.

5.1 The menus

The DA-98 has 12 menu groups, labelled from 0 through 9, and E and F. These are referred to in this manual as “menu group 0”, menu group E”, etc.

The menu which is used to select these 12 menus is called the “top” menu, and looks like this





```

Select Menu Group
  0 1 2 3 4 5 6 7
  8 9 - - - - E F
Dly/Tr.Cpy/Vari/Loc
  
```

The bottom row of the display is used as a quick reference to remind you of the currently-set value or the contents of the menu group.

5.1.1 Navigation around the menu system

The cursor keys [25] are used to navigate round the screen. In this manual, we use the following terms for these keys:

CURSOR key	Term used in text
	UP key
	DOWN key
	LEFT key
	RIGHT key

Notice that in the top menu, as you move the cursor between menus, the bottom line will change, reflecting the contents of the menu.

5.1.2 Using the ENTER key

From the top menu, when the cursor is beside the desired menu group, press **ENTER** [25] to enter that menu group. The screen will change, and the choices within that group will be shown.

These are the choices within menu 0:

```

Delay      Memo 1
Trk Copy  Memo 2
Vari Sed  Loc Pre
  1      0000 Sample
  
```

Use the cursor keys to navigate between menu items within the group. The bottom line of the display will change to show the currently-set values for the parameter beside the cursor.

When the cursor is beside the desired parameter, press the **ENTER** key. You can now change the values of that parameter.

5.1.3 The ESCAPE key

The **ESCAPE** key is used to move up through the menu hierarchy (from menu screens to sub-menus to the top menu). It is therefore used if you enter the wrong menu by mistake.

For a full description of the menu tree, see 12, “Menu and parameter reference”.

- There is also an alphabetical index of menu functions and items on page 12-8.

5.1.4 Editing values

When a parameter has been selected for editing, the function of the cursor keys is changed.

If there is only one parameter, the **LEFT** and **RIGHT** keys are not used, and the **UP** and **DOWN** keys are used to change the value of the parameter. If the parameter is a number, the **UP** key increases the value and the **DOWN** key decreases the value.

If there is more than one parameter or there are “sub-values” to the parameter, such as in the following example (menu group 8), the functions are a little changed:

```

Gen Start Fs shift
Gen Mod   TcRec Src
01:33:12:17 30NDF
  
```

Here, the internal timecode generator start time can be set. Obviously, we could edit the “frames”

field and keep pressing the **UP** key, but one hour would be $30 \times 60 \times 60 = 10,800$ key presses!

To avoid this, the **LEFT** and **RIGHT** keys move the cursor between the “fields”; in this case, hours, minutes, seconds and frames.

Regardless of whether one value or several sub-values have been edited, the changes to the values are made immediately. The cursor keys can then be used for navigation again.

In most time-based menus, when the “frames” field is being edited, the value can be changed from `00` to the number of frames in 1 second (the exact number varies between settings) and back to `00`.

However, if the cursor is moved to an invisible “field” to the right of the frames field, incrementing the value of the frames field above the number of frames in a second will increment the seconds field.

As an example:

- 1) **The menu screen shows: “00:01:43:29” when the frame rate is 30fps.**

- 2) **Press UP.**

- 3) **The menu screen shows: “00:01:43:00”.**

However:

- 1) **The menu screen shows “00:01:43:29_”.**

- 2) **Press UP.**

- 3) **The menu screen shows: “00:01:44:00_”.**

5.1.5 Resetting a menu value

Sometimes it is necessary to reset a menu value to a default value.

To do this quickly, hold down the **UP** key and press the **DOWN** key (or hold down the **DOWN** key and press the **UP** key). If the menu value is a time value in hh:mm:ss:ff format, all the fields will be reset to zero. If there is more than one independent field in a menu screen, use the cursor to point to the value that you want to reset to zero.

5.1.6 Changing menu values fast

Sometimes it is useful to be able to change a value fast (for instance, time values such as minutes and seconds). To do this, hold down the **UP** or **DOWN** key and press the **ENTER** key. The values will change faster as long as the **ENTER** key is held down.

5.1.7 Blanking the screen display

There are times when you may want to blank the backlit screen display (for instance, the light may be a visual distraction, or you may want to discourage tampering fingers).

- 1) **Press the ENTER key, and while holding it down, press ESCAPE.**

You can also hold down the **ESCAPE** key and press **ENTER**.

- 2) **The screen will blank, and the back light will go out.**

- 3) **To restore the screen display, press any of the following: ENTER, ESCAPE, or any of the CURSOR keys.**

The screen will be relit, and show the top menu.

NOTE

This can be used as an alternative way of returning to the top menu when you are inside the menu hierarchy

5.2 Function key modes

These keys are often used to jump to frequently-used menus (see 5.3, “Assigning menus to function keys”), but their function can be changed, as described here:

- 1) **Press and hold down the SHIFT key [24], and while holding it down, press the MEMO 2 key [14] to enter the Function Key Mode menu.**

As an alternative to the method above, you can go to menu group 7, move the cursor to `Function Mode` and press **ENTER**.

- 2) This menu gives you three choices, Menu, Locate Position and 10 Key:

```
Function Key Mode
Select

Menu
```

Menu uses the function keys as a quick way of jumping around the menu system (see 5.3, “Assigning menus to function keys”).

Locate Position assigns the ten function keys to location memories (see 8.2.1, “Storing a function key location memory”).

10 Key allows you to use the function keys as a numeric keypad for direct entry of numerical data (see 5.2.2, “Using the function keys as number keys”).

- 3) Select the option with the UP and DOWN keys.

NOTE

When you change the function of the “soft” keys between menu and location functions, the values assigned to the other function are not lost, and will be restored when you next change the function of the soft keys.

5.2.1 The SHIFT key and function keys

Usually, the 10 function keys and the LOC 2/PRE-SET and MEMO 2/ +/- keys perform the duties as marked on the top of their labels (e.g. key [19] usually works as the AUTO MON key).

To use the keys as function keys (whether location keys, preset menu keys or as number keys), press the SHIFT key.

The SHIFT indicator will start to flash.

While it is flashing, these keys are used as described on the bottom row of their labels (e.g. key [19] now becomes function key 7 (F 7)).

Press the SHIFT key again to stop the indicator flashing and return the keys to their original functions.

5.2.2 Using the function keys as number keys

When the Function Key Mode parameter has been set to 10 Key (see above), you can use the function keys as number keys for direct entry of numerical data.

The function key number is used to enter the digit (F 1 enters a 1, F 2 enters a 2, etc.) except for F 10, which enters a 0.

When you have entered the value using the function keys as number keys, you should press the PRESET key ([23]) to confirm the value you have just entered.

The following is a step-by-step guide to entering a value (1 minute and 5 seconds) into the Locate Pre-roll parameter (see 8.1.3, “Setting the location pre-roll time”).

- 1) Set the function key mode to 10 Key, as described above (page 5-2).
- 2) Go to menu group 0, move the cursor to Loc Pre, and press ENTER:

```
Locate Pre-roll

00min00sec
```

- 3) Press the SHIFT key [24]. The indicator will start to flash.
- 4) Press the F 1 key [9]:

```
Locate Pre-roll

00min01sec
```

The bottom line of the display will start to blink, showing that you are entering numerical data.

Notice that the number is entered from the right of the fields, even though the cursor position is not at the right of the field.

Section 5 – Menu operations

- 5) Press the F 10 key [22] (to enter a 0):

```
Locate Pre-roll
00min10sec
```

- 6) Press the F 5 key [13]:

```
Locate Pre-roll
01min05sec
```

- 7) The numbers for this value have now been entered, but the value itself has not. Press the LOC 2 (PRESET) key [23] to enter the value.

The bottom line of the display will stop blinking.

- 8) You can use the UP and DOWN keys to adjust the value you have just entered.
- 9) Press SHIFT again to restore the function keys to their “non-function” values.

NOTE

Some parameters (e.g. offsets) can take either positive or negative values. To change the sign of the value, use the MEMO 2 (+/-) key [14] to toggle between positive and negative values.

You can use the function keys as number keys in almost any menu where direct numerical input is possible.

You cannot use these keys as number keys when there are only two choices (even if they are numerical). An example of such a menu is the Recharge Mode menu (page 10-13), where the two options for the Window value are 1 second and 2 seconds. This parameter should be set using the UP and DOWN keys, not the number keys.

5.3 Assigning menus to function keys

It is quite likely that you will find yourself using a few of the same menu functions many times (for instance, manual adjustment of punch points) and

many of the menu functions only rarely (for instance, whether the DA-98 is a master or a slave unit).

Some of the keys below the tape counter ([9] through [13], and [18] through [22]) can be used as “soft keys”, providing instant access to the menu screens you use most often.

5.3.1 To assign a menu screen to a key

- 1) Set the function key mode to Menu as described in 5.2, “Function key modes”
- 2) Use the cursor and ENTER keys to get to the menu function you want to assign to a key.
- 3) Press the SHIFT key [24] (the indicator will flash).
- 4) Press the PRESET key [23]. The following will appear on the display.

```
Function Preset
"Push Function Key"
```

- 5) Press the key (F 1 through F 10) to which you want to assign the menu screen.

This will assign the menu screen to the key and the SHIFT indicator will go out.

5.3.2 Recalling an assigned menu function

- 1) Press the SHIFT [24] key (the indicator will flash).
- 2) Press the F key (1 through 10) which has been assigned to the menu function you want to recall.

The menu screen will be recalled, and the SHIFT indicator will go out.

6 – Basic operations

This section explains some of the basic operations using the DA-98. Section 8, “Advanced operations” describes more advanced operations.

Most operations on a DA-98 are similar to those on a traditional analog multitrack recorder, but we suggest that you read this section and the next to learn about the features of the DA-98.

6.1 Formatting a tape

Before you use a tape in the DA-98, you must first format it. This marks internal synchronization patterns for the servo to follow on subsequent passes through the tape as well as the subcode data (ABS). No audio data is normally recorded during a formatting operation (but see below).

While formatting is proceeding, you cannot perform any other transport operation except stopping the tape.

You cannot change the sampling rate while formatting is in progress.

- 1) **Switch on the DA-98 and load a tape into the tape loading slot [3]. As the tape is loaded and threaded, the tape counters will show**

--LOAD--

For details of tapes that you can use in the DA-98, see 1.5, “Recommended tapes”.

- 2) **Press REW [32] to take the tape to the beginning. When the beginning of the tape is reached, the tape counter will show *bot* (“beginning of tape”).**
- 3) **Press the FORMAT/Fs switch [6]. The FORMAT indicator will start blinking. Press the FORMAT/Fs switch again within 5 seconds. The FORMAT indicator will then light steadily.**

If you do not press the **FORMAT/Fs** switch twice within 5 seconds, the indicator will go out. This is

a feature designed to stop you formatting a tape accidentally.

NOTE

If you do press the **FORMAT/Fs** switch twice so that the indicator lights steadily and you then change your mind about formatting the tape, you can use the **CLEAR** key [11] to cancel the operation.

- 4) **Now use the FORMAT/Fs switch to select the sampling frequency (either 44.1kHz or 48kHz).**

The sampling frequency that you select depends on the eventual use for the recording. For audio work, selecting 44.1kHz will allow you to produce CD master tapes with no frequency conversion.

NOTE

If a digital signal is received at the **DIGITAL I/O** jack [45] as selected and shown by the **DIGITAL IN** switch and indicator [15], the DA-98’s recording and playback sampling frequency is automatically determined by the sampling frequency of the input signal and you cannot change it.

- 5) **To start formatting the tape, hold down the RECORD key [36] and press the PLAY key [35].**

NOTE

The tape counter may show a negative ABS time for a short while at the start of the formatting process. While it is displaying a negative value, no audio recording can take place.

- 6) **The tape will format to the end, and then rewind automatically, stopping at the *00000000* position.**

You are now able to use the tape for recording.

It is possible to format tapes on a number of DTRS units simultaneously. For details, see 9.4.1, “Synchronized formatting”.

6.1.1 Aborting the format process

To abort the process before formatting actually takes place (i.e. you have pressed the **FORMAT/Fs** switch twice in error), press the **CLEAR** key [11]. The **FORMAT** indicator will go out.

As explained earlier, the only transport operation you can perform once formatting has started is to stop the tape.

Section 6 – Basic operations

However, we do not recommend interrupting the formatting process, but suggest that you let the tape run to the end.

If you interrupt the formatting (or the formatting is interrupted by a power cut or events beyond your control), rewind the tape and start the format from the beginning of the tape again.

6.1.2 Recording while formatting

If you have armed any tracks (you have pressed its **REC FUNCTION** switch [28] and the indicator is flashing), any audio signal routed to that track will be recorded while formatting is in progress.

NOTES

- If you have recorded and formatted part of a tape, and you wish to continue formatting and recording on the rest of the tape (“assembly”), you should rewind to a pre-formatted, blank section of the tape and resume formatting and recording from there.
- Recording and formatting will continue at the sampling frequency used on the first part of the tape.
- Avoid re-starting recording and formatting from an unformatted section of the tape.

6.2 Recording the first tracks

There are a number of different ways of recording the first tracks. However, all follow the same basic principles.

NOTES

- When using a newly-formatted tape, we suggest that you record a blank “leader” about 30 seconds long, starting from the beginning of the tape, to avoid dropout. Leave a similar recorded blank “trailer” at the end of the recording. You can use the Rec Mute function as a convenient way of recording silence (see 8.12, “REC MUTE (recording silence)”).
- If the tape counter shows a negative value, you cannot record on the tape at that position.

6.3 Preparing to record

- 1) **If you have not already loaded a formatted blank tape, do so now.**
- 2) **Make sure that varispeed is turned off (check the VARI SPEED indicator [2] and see 8.5.2, “Resetting the speed to standard” if necessary).**

3) **If you are recording from a digital source, press the DIGITAL IN switch [15]. The indicator will light.**

4) **Select the input which will be routed to each track on which you will be recording.**

This may involve the use of an external patch bay (analog), but the DA-98 also incorporates a “virtual patch bay” which can be used for signal routing; both digital and analog. This is accessed through the Track Copy function (see 8.11.1, “Track Copy (channel-to-track routing)”).

With a digital recorder such as the DA-98, track crosstalk is almost negligible (better than 90dB at 1kHz). For this reason, you do not have to worry so much about the constraints of choosing physical track locations as you do with analog recordings.

If you need to copy a track to another track later in the recording process, remember that track copying in the digital domain will add no noise or distortion. A digital copy is a “clone” of the original, and no loss of quality is incurred.

6.3.1 Write-protecting cassettes

If you attempt to record on a cassette where the write-protect tab has been closed, an error message will appear on the screen as you press the **RECORD** key. Recording is, of course, not possible on a write-protected cassette.

Hi8 cassette write tabs work in the opposite manner to DAT cassettes, and “closed” means “write-protect”.

If the tape is write-protected, the **REC INHI** indicator to the left of the tape counter will be lit. Eject the tape, open the write-protect tab, replace the cassette, and try again.

NOTE

Sony Hi8 cassettes (and those from some other manufacturers) have the words “SAVE” (write-protected) and “REC” (write-enabled) molded into the cassette shell by the protection tab.

6.3.2 Recording the basic tracks (i)

1) **Arm the tracks on which you wish to record.**

Press the **REC FUNCTION** key of these tracks; the indicator will start flashing.

- 2) **Adjust the input signal levels so that the track meters read high, but the OVER segment does not light.**

NOTE

Use the reference level you have chosen (see 8.7, “Reference levels”) to be your “nominal” level.

- 3) **Hold down the RECORD key, and press the PLAY key. The tape will start moving and recording will start.**

The **REC FUNCTION** indicators of all tracks will light steadily.

When you start recording, the point at which recording starts is automatically stored into memory for punch-in purposes.

- 4) **To stop recording and stop the tape, press the STOP key. You can also press the PLAY key, which will continue the tape movement, but stop recording.**

6.3.3 Recording the basic tracks (ii)

This is an alternative method of recording basic tracks on a blank, formatted tape.

- 1) **Arm the tracks and adjust the levels as described in [1] and [2] above (6.3.2, “Recording the basic tracks (i)”).**
- 2) **Press the PLAY key. The tape will start moving.**
- 3) **When you reach the point at which you want to start recording, press the RECORD key.**

The **REC FUNCTION** indicators of all armed tracks will flash.

The **REC FUNCTION** indicators of all armed tracks will light steadily.

The point at which recording starts is automatically stored into memory for punch-in purposes.

- 4) **Stop recording as described above.**

6.3.4 Replaying the first tracks

When you have positioned the tape at the beginning of the recording you have just made (or at the pre-roll point), you can start playing back the tape.

- 1) **Turn off the RECORD FUNCTION switch of the track you have just recorded.**

We suggest turning off the **RECORD FUNCTION**. This will prevent you from accidentally hitting the **RECORD** key and going into record mode, overwriting what you have already recorded.

- 2) **Make sure that the INPUT MONITOR of the track you have just recorded is turned off (see 7.1.1, “ALL INPUT [18] and INPUT MONITOR [29]”).**
- 3) **Rewind the tape to the point that you started recording and press PLAY.**

6.4 Overdubbing

Overdubbing subsequent tracks is carried out in a very similar way to recording the first tracks.

If you are unsure about the difference between monitoring modes as implemented on the DA-98, now is a good time to read the section 7, “Monitoring modes”.

Obviously you will want to record while you listen to the off-tape signals from previously-recorded tracks and the input source on tracks where recording is taking place.

Note, however, that the use of confidence mode when overdubbing (see 7.2, “Confidence mode”) is not recommended, as the off-tape replay signals will be delayed, making it impossible to provide accurate cues.

6.5 Track bouncing

Though the DA-98 provides a method of copying tracks digitally (see 8.11.1, “Track Copy (channel-to-track routing)”), there is no way of combining tracks within the DA-98.

If you need to combine tracks, this must be done through an external console, routing all tracks to be combined through an output group, and routing that group to the appropriate track input.

6.6 Punch-in and punch-out

There are a number of ways in which the DA-98 can be used to perform reliable punch-in and punch-outs automatically. Punch points can be set

Section 6 – Basic operations

and edited to frame accuracy, either from a cue list or “on-the-fly” in real time.

The DA-98 provides a rehearsal mode which simulates the punching process, allowing the artists to perfect the timing of the new material.

The mechanics of punching on a digital recorder appear to the operator to be the same as on an analog recorder.

Crossfading, however, is an important and useful function on digital recorders, to ensure continuity between original and punched material. In the case of the DA-98, this crossfade time is adjustable from 10 milliseconds to 200 milliseconds (see 8.4, “Crossfade times”).

The **AUTO MON** mode is essential here: in both rehearsal and punch modes, the material prior to the punch point is monitored off tape. The monitoring of armed tracks changes to source while rehearsals and punching are carried out and then changes to off-tape again after the punch-out point.

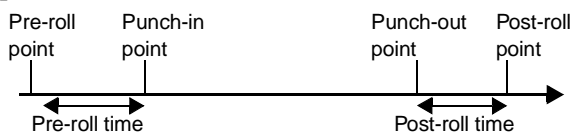

Rehearsal learn		
TAPE	SOURCE	TAPE
Rehearsal		
TAPE	SOURCE	TAPE
AUTO PUNCH		
TAPE	SOURCE	TAPE
Replay check		
TAPE	TAPE	TAPE

NOTE

Though you can perform punch recording in either the confidence mode (see 7.2, “Confidence mode”) or the ALL INPUT mode (see 7.1.1, “ALL INPUT [18] and INPUT MONITOR [29]”), the monitoring in these modes does not make it easy to perform accurate punch operations. We suggest that you turn these modes off if you want to perform punch-ins.

6.6.1 Automatic punch point setting

Whenever recording takes place, the time when recording begins is automatically stored as a

punch-in time, and the time when recording stops is stored as a punch-out time.

This is not usually the way in which you will want to set the punch points, however. There are several alternative ways in which you can set these points, as described below:

6.6.2 Setting punch points “on the fly”

This method demands sharp reflexes (but you can edit the punch points later as we show below).

1) **Press the AUTO MON key [19] (the indicator will light).**

2) **Arm the track(s) on which you will be recording (use REC FUNCTION).**

3) **Press the RHSL (rehearsal) key [9].**

The indicator will flash, showing that the DA-98 is in “rehearsal learn” mode.

4) **Rewind the tape to before where the punch is to occur.**

5) **Start playing the tape (press PLAY).**

You will monitor the off-tape signals.

6) **At the point where the punch is to occur, press RECORD.**

The **RECORD** key will flash, and the **REC FUNCTION** indicator of any armed tracks will light steadily.

The **INPUT MONITOR** indicator of any armed tracks will light and monitoring will change to input source recording for these tracks.

At any time when the rehearsal key is lit or flashing, this means that recording will not actually be carried out, even if the **RECORD** key and/or the **REC FUNCTION** indicators are lit.

7) **At the point where you want to punch out, press PLAY.**

The **REC FUNCTION** indicator of any armed tracks will start flashing again. The **RECORD** key will go out.

The **INPUT MONITOR** indicator of any armed tracks will go out, and monitoring of these tracks will return to off-tape status.

- 8) After the post-roll period, the tape will return to the pre-roll point (the punch-in point minus the pre-roll offset).

The **RHSL** indicator will now light steadily, showing that the DA-98 is in rehearsal mode.

NOTE

If you want to alter the pre-roll and post-roll times, see 6.6.4, “Editing the pre-roll and post-roll times”. The punch-in and punch-out points will remain the same while you change the pre- and post-roll times.

6.6.3 Setting punch points using the menus

- 1) Press the **RHSL** (rehearsal) key [9] twice (or until the indicator lights steadily).
- 2) Press the **AUTO MON** key [19] (the indicator will light).
- 3) Go to menu group 1 and select the **In Point** option using the cursor keys and **ENTER**:

```

Punch-in Point

00:09:21:12  ABS
```

- 4) Use the **LEFT** and **RIGHT** keys to select the “field” (hours, minutes, seconds or frames) that you want to edit, and use the **UP** and **DOWN** keys to change the values.

You can also use the function keys to enter the value directly, as described in 5.2.2, “Using the function keys as number keys”.

- 5) Press **ESCAPE** to return to menu group 1.
- 6) Select **Out Point** and repeat the process.

NOTE

You can also use this process to edit punch points which have been set “on the fly”.

- 7) Locate the tape to the punch-in point (minus the pre-roll time) by pressing **LOC 1** [22].

6.6.4 Editing the pre-roll and post-roll times

As shipped from the factory, the DA-98 will position the tape 5 seconds before the punch-in point, whether this has been set by you, or set automatically (as described above).

The post-roll is factory set to 3 seconds. You can alter both these times using the following method:

- 1) Enter menu group 1 and move the cursor to the **Pre/Post** menu option:

```

In Point X-Fade
Out Point Dither
Pre/Post Rec Mute
00:00:06:00  ABS
```

- 2) Press **ENTER** to set the pre-roll and post-roll times:

```

Pre-roll Post-roll

Pre Post
00m05s 00m10s
```

- 3) Use the **LEFT** and **RIGHT** keys to position the cursor by the “field” (minutes or seconds) that you want to change and use the **UP** and **DOWN** keys to alter the value.

You can also use the function keys to enter the value directly, as described in 5.2.2, “Using the function keys as number keys”.

Since there is little point in setting pre- and post-roll times to frame accuracy, you can only set these values to second accuracy.

The minimum values you can set are 5 seconds and the maximum value is 59 minutes 59 seconds.

Any punch operation from now will take your setting for pre-roll and use it when locating the tape to the punch-in point.

For example, if your pre-roll time has been set to 10 seconds (00:00:10:00), and the punch-in point is at 00:06:03:12, the tape will locate to 00:05:53:12 when starting rehearsal or punch-in.

Section 6 – Basic operations

- 4) **Post-roll is set in the same way. Use the LEFT and RIGHT keys until the cursor is by the `Post` field, and repeat the steps above.**

The minimum value for post-roll is 3 seconds.

6.6.5 Rehearsing the punch-in

After you have set the punch points, and you have located the tape to the pre-roll point, as described above, you can rehearse the punch process.

- 1) **Press the RHSL key [9] so that the indicator lights steadily.**

This indicates that you are now in rehearsal mode.

- 2) **Press PLAY. The tape will start playing from the pre-roll point.**

- 3) **At the punch-in point, monitoring will change to source.**

The **RECORD** key will flash, and the **REC FUNCTION** indicator of any armed tracks will light steadily. However, recording will not be carried out.

- 4) **At the punch-out point, monitoring will change back to off-tape monitoring.**

The tape will continue playing to the post-roll point and then rewind to the pre-roll point.

NOTE

If the **AUTO PLAY** mode is active (press the **AUTO PLAY** key [12] so that the indicator lights), playback will start again as soon as the pre-roll point is reached.

- 5) **Repeat the rehearsal process until you are satisfied with the performance.**

6.6.6 Interrupting a rehearsal or punch recording

Very often while rehearsing a punch-in, you will not want to run the tape all the way to the punch-out point (an entry cue is missed, or a mistake is made early on in the take). In these cases, the following procedure applies to both rehearsal and punch recording:

- 1) **While the tape is running, press the LOC 1 key [22].**

There is no need to press **STOP** first.

The tape will return to the punch-in point, minus the value specified in the punch-in offset (6.6.4, “Editing the pre-roll and post-roll times”).

NOTE

The pre-roll location time (see 8.1.3, “Setting the location pre-roll time”) is not used here.

- 2) **Pressing PLAY will then re-start the rehearsal or punch-in process.**

NOTES

- Pressing the **LOC 2** key will locate the tape to the punch-out position minus the punch-in pre-roll time.
 - These functions are only operative when the **RHSL** or **AUTO PUNCH** indicators are lit or flashing. When they are off, the **LOC 1** and **LOC 2** keys will act normally.
 - If the **SHIFT** key has been pressed, and the **SHIFT** indicator is flashing, the **LOC 1** and **LOC 2** keys will act as function keys (see 5.2.1, “The SHIFT key and function keys”).
-

6.6.7 Recording the punch-in

- 1) **Make sure the tape is at the pre-roll point, and press the AUTO PUNCH key [10] once.**

The indicator will flash, showing that the DA-98 is in auto-punch mode.

- 2) **Press PLAY. The tape will start playing.**

At the punch-in point, the **RECORD** indicator will light steadily, as will the **REC FUNCTION** indicators of any armed tracks. Monitoring will change from off-tape to source and the **INPUT MONITOR** of any armed tracks will light.

Recording will now actually take place. Any recorded material which was previously on the armed tracks between the punch points will be replaced by the new recording.

- 3) **At the punch-out point, the monitoring will go back to off-tape (the INPUT MONITOR indicators of armed tracks will go out), and when the post-roll point is reached, the tape will rewind to the pre-roll point.**

NOTE

If the **AUTO PLAY** mode is active (press the **AUTO PLAY** key [12] so that the indicator lights), playback will start again as soon as the pre-roll point is reached.

- 4) **The AUTO PUNCH indicator will light steadily, showing that the DA-98 is now in replay mode.**

6.6.8 Replaying the punched material

- 1) **To replay the punch-in, press the PLAY key.**
Playback will start (the **REC FUNCTION** indicators of the armed tracks will continue to flash).
- 2) **At the post-roll point, the tape will automatically rewind to the pre-roll point.**
- 3) **If you want to record the punch-in again, press the AUTO PUNCH key [10] so that the indicator flashes, and repeat the process described above.**
- 4) **If you are satisfied with the punch-in, follow the steps below, otherwise, press LOC 1 to return to the punch-in point, press the AUTO PUNCH key so that the indicator flashes, and repeat the take.**

6.6.9 Exiting punch-in mode

- 1) **Disarm any armed tracks (press the REC FUNCTION switches so that the indicators go out).**
- 2) **Press the CLEAR key [11].**
This will exit the **AUTO PUNCH** (or rehearsal) mode.

The **LOC 1** and **LOC 2** keys will return to their usual functions, but the punch points are still retained in memory.
- 3) **Press the AUTO MON key so that the indicator goes out.**

Normal monitoring modes will now be in operation (see 7, “Monitoring modes”)

7 – Monitoring modes

NOTE

We strongly advise you to read this section – the effective use of multitrack monitoring is one of the keys to an efficient recording session.

Like all multitrack recorders, the DA-98 has a number of different monitoring modes, depending on the current monitor status, transport status and whether the track is armed or not.

In addition to the “standard” modes common to most multitrack recorders, the DA-98 includes two new monitoring features: the **CONFIDENCE MODE** [17], and the individual track **INPUT MONITOR** switches [29]. These are described in this section.

7.1 Monitoring controls

The controls which affect monitoring are:

- **ALL INPUT** [18]
- **INPUT MONITOR** [29]
- **REC FUNCTION** [28]
- **CONFIDENCE MODE** [17]
- **AUTO MON** [19]
- **SHTL MON** [20]

7.1.1 ALL INPUT [18] and INPUT MONITOR [29]

When these are active, the signal from the DA-98’s outputs will always be the input source signal received at the input for the appropriate track or tracks.

When the **ALL INPUT** key is pressed, its indicator and the **INPUT MONITOR** indicators of all tracks will light. Monitoring for all tracks will be source monitoring, rather than off-tape.

When the **ALL INPUT** key is pressed again to turn off this mode, the status of the **INPUT MONITOR** indicators will revert to the status before the **ALL INPUT** key was turned on.

The **INPUT MONITOR** switches are disabled until the **ALL INPUT** key is turned off (the **ALL INPUT** indicator goes out).

The **INPUT MONITOR** switches allow you to perform the same function on a track-by-track basis, allowing you to adjust the level balance between off-tape monitoring and the input source, and are available from a number of modes as described in the table below.

7.1.2 AUTO MON

When replaying a track, you will usually want to monitor the program material recorded on the tape. However, there are times when you want to monitor the source input rather than the off-tape signal, even in play mode.

The following table shows what will be monitored from a track. This depends on the **AUTO MON** and the **REC FUNCTION** switch settings, and on the transport mode currently engaged.

AUTO MON	REC FUNCTION (track arming)	PLAY	RECORD	STOP, etc.
ON	ON	Tape	Source	Source
ON	OFF	Selectable ^a	Selectable	Selectable
OFF	ON	Selectable	Source ^b	Selectable
OFF	OFF	Selectable	Selectable	Selectable

a. “Selectable” as used here means that individual tracks’ **INPUT MONITOR** switches can be used to switch between source and tape monitoring. Off-tape monitoring is obviously only possible when the tape is moving (in recording or playback modes).

b. Confidence mode (see 7.2, “Confidence mode”) is possible in this mode (**AUTO MON** off and **REC FUNCTION** on) and when confidence mode is active, the monitoring is selectable between source and tape.

The **AUTO MON** function therefore allows you to switch automatically between monitoring modes as the tape transport function changes.

NOTE

The **ALL INPUT** key overrides the monitoring mode from the table above (when this mode is active, monitoring for all tracks will always be source monitoring, regardless of the status of **AUTO MON**).

7.1.3 Shuttle monitoring

In addition to these modes, there is one further control, **SHTL MON** [20], that affects monitoring, but only in one special case – shuttle mode. Usually, when shuttling the tape, you will want to monitor off-tape. However, if a track is armed, you may want to listen to the source input signal, rather than the off-tape recording.

NOTE

ALL INPUT overrides any shuttle monitoring selections described below. Any shuttle monitoring while **ALL INPUT** is on will always be source monitoring.

The **SHTL MON** key has no effect when **AUTO MON** is off. While shuttling, you can use tracks' **INPUT MONITOR** switches (regardless of arming status) to change between source and off-tape monitoring.

When the **AUTO MON** and **SHTL MON** are both on (the indicators will light), the output from all **armed** tracks will be the source input. This cannot be changed.

NOTE

You can always (regardless of any other status except **ALL INPUT**) use the **INPUT MONITOR** switch of unarmed tracks to switch between source and tape monitoring.

If **AUTO MON** is on, but **SHTL MON** is off, all armed tracks will monitor off-tape in shuttle mode. This cannot be changed.

NOTES

You can also disable off-tape shuttle monitoring with the Shuttle Mute function (see 8.6.2, “Shuttle muting”).

Shuttle monitoring is attenuated by 12 dB compared with other monitoring modes. This helps to avoid damage to tweeters, etc. when shuttling fast.

7.2 Confidence mode

When actually recording in a studio, it is usual to monitor the input signals, rather than the tape. This allows accurate synchronization between studio events and the actions of the control room staff. If a “glitch” is later discovered in the recording, or it is discovered that a signal has been

wrongly routed, resulting in an unwanted recording being produced, it is a relatively simple matter to re-record the take.

In a live recording situation, this luxury is not possible. One can hardly ask an orchestra giving a concert to repeat a movement of a symphony for re-recording purposes!

For this reason, the DA-98 includes a confidence mode which permits off-tape monitoring on a track-by-track basis while recording is in progress.

Confidence mode provides monitoring off-tape while recording for all tracks, except those tracks whose **INPUT MONITOR** switch is active. The monitoring of these tracks will be the input source, not tape.

The actual mechanics of how this is accomplished internally are quite complex, but the result is that off-tape signals are delayed by about 240 milliseconds relative to the input signal. This means that it is not recommended that you perform punch-ins, etc. in the confidence mode.

In the confidence mode, overdubbing will be out of sync with previously recorded tracks, as well as with the input source.

We suggest you use confidence mode only when laying down long takes of basic tracks which will not need punching for correction (e.g. laying down tracks from a video worktape, or classical live recordings). You may also choose to use confidence mode when you are dubbing from another audio multitrack tape to the DA-98, to ensure the quality of the transfer.

Another use for the confidence mode is when you are recording using dither (see 8.13, “Dither”). You may want to check the effects of dither on the re-quantized recording as the tracks are being laid down.

7.2.1 Arming tracks in pairs

In confidence mode, tracks are armed and unarmed in pairs (1+2, 3+4, 5+6, 7+8).

NOTE

Turning on confidence mode unarms any tracks which have been armed prior to turning on confidence mode.

- 1) **Pressing the REC FUNCTION of either track 1 or track 2, for instance, will arm both tracks 1 and 2.**
- 2) **Pressing either track 1 or track 2's REC FUNCTION key will unarm both tracks (regardless of which track's REC FUNCTION key was used to arm the tracks).**
- 3) **If confidence mode is turned off, track arming and unarming can now be carried out on a track-by-track basis.**

Even if tracks were armed in pairs while confidence mode was enabled, when confidence mode is disabled, they can now be unarmed individually.

7.2.2 Using confidence mode

- 1) **Adjust the recording levels on all armed tracks.**
- 2) **Turn off AUTO MON mode and make sure that the ALL INPUT switch is off.**

NOTE

Using confidence mode, it is possible to monitor some tracks off-tape during recording while monitoring the input source of others. However, as explained above, the way in which the confidence mode is implemented means that the off-tape signals are delayed by 240 milliseconds relative to the input source signals. Hence, the off-tape and source signals will be out of sync, and we suggest that if "mixed-mode" monitoring is to be carried out, the same operator should not attempt to listen to both off-tape and source monitor signals.

- 3) **Press the CONFIDENCE MODE key [17] once. The indicator will flash.**
- 4) **Press the CONFIDENCE MODE key again within five seconds of pressing it for the first time. The indicator will light steadily.**

If you do not press the **CONFIDENCE MODE** key twice within five seconds, the indicator will stop

flashing. This is to stop you from entering the confidence mode by accident.

- 5) **To leave confidence mode, press the CONFIDENCE MODE key once.**

8 – Advanced operations

8.1 Autolocation

The DA-98 contains two location memories, accessible through the **LOC 1** and **LOC 2** keys ([22] and [23]). These also allow a “A↔B repeat” facility, which allows you to rehearse part of a mixdown, for instance. These two location memory points are referred to as “MEMO 1” and “MEMO 2”.

In addition to these two location memories, the DA-98 can also store 10 more location memories, which are accessed through the function keys ([9] through [13] and [18] through [22]).

As with the punch recording points (see 6.6, “Punch-in and punch-out”), it is possible to set and edit these points in a number of ways.

8.1.1 Setting MEMO 1 and MEMO 2 “on the fly”

This can be done regardless of the current status of the tape transport (playing, recording, winding, stopped, or shuttle).

1) Press the MEMO 1 or MEMO 2 key; [13] or [14].

The current tape position will be stored to the appropriate location memory (MEMO 1 or MEMO 2).

The display screen will indicate that the location memory point has been stored.

```

Position saved in
location memory

10:03:12:24      ABS
  
```

8.1.2 Checking, editing and manually entering MEMO 1 and MEMO 2

The checking, editing, and manual entry of MEMO 1 and MEMO 2 location points are all essentially the same operation. Location points can be edited and entered to frame accuracy.

1) Go to menu group 0:

```

Delay      Memo 1
Trk Copy  Memo 2
Pitch      Loc Pre
10:04:12:12      ABS
  
```

If you are only checking the location points, you can see the value of the location point on the bottom line of the display screen. As you move the cursor between Memo 1 and Memo 2, the value shown will change appropriately. Press **ESCAPE** when you have finished checking.

2) Move the cursor to Memo 1 or Memo 2 and press ENTER to select the location point to edit.

```

Memo 1

00:04:12:12      ABS
  
```

3) Use the LEFT and RIGHT keys to select the field you wish to edit (hours, minutes, seconds or frames) and the UP and DOWN keys to change the value.

You can reset the value of a location point field to “000” by holding down the **UP** key and pressing the **DOWN** key (or the other way round).

There is also an “invisible” field to the right of the location value, which you can use to fine-tune the location point time, as described in 5.1.4, “Editing values”.

You can also use the function keys to enter the value directly, as described in 5.2.2, “Using the function keys as number keys”.

8.1.3 Setting the location pre-roll time

When you locate to a location memory (whether it is one of the MEMO 1/2 points or the 10 “function key” memories), the tape will stop at the memorized location point, minus a pre-defined pre-roll time.

As shipped, the DA-98’s default location pre-roll time is 0 seconds. You can edit this to a value between 0 seconds (the tape will locate to the

Section 8 – Advanced operations

exact location point) and 59 minutes, 59 seconds, in 1 second increments.

NOTE

This pre-roll time is independent of the punch pre-roll time (see 6.6.4, “Editing the pre-roll and post-roll times”).

- 1) **Go to menu group 0, move the cursor to Loc Pre, and press ENTER.**

```
Locate Pre-roll
00min06sec
```

- 2) **Use the LEFT and RIGHT keys to select the field you wish to edit (minutes or seconds) and the UP and DOWN keys to change the value.**

You can also use the function keys to enter the value directly, as described in 5.2.2, “Using the function keys as number keys”.

When you go to a location point, the tape will now locate to the location point, minus the value you have just entered. For instance, if the location point is at “00:12:04:03” and you have set a location pre-roll time of 5 seconds, the tape will locate to “00:11:59:03”.

8.1.4 Moving to MEMO 1 and MEMO 2

When you have set the location memories as described above, you simply need to press the **LOC 1** or **LOC 2** keys ([22] or [23]) to move the tape to these location points.

The display will show the location memory value and the pre-roll time.

```
Locate      Preroll
Point       Time
10:02:23:08 00m03s
```

The tape will locate to the location memory minus the location pre-roll time, as described above.

8.2 Function key location memories

As explained earlier, the ten “soft” function keys can be assigned to locate to memorized positions.

8.2.1 Storing a function key location memory

In addition to the MEMO 1 and MEMO 2 memories, you can also assign 10 additional memories to the function keys.

The function keys must be in “location memory” mode (see 5.2, “Function key modes”).

The tape transport can be in any function (play, record, stop, shuttle) when you store a memory and assign it to a function key.

- 1) **Press the SHIFT key.**

The **SHIFT** indicator will start to flash.

- 2) **Press the LOC 2/PRESET key [14]**

```
Function Preset
PUSH FUNCTION KEY
Locate Position
```

- 3) **Press the function key to which you want to assign a memory.**

The display screen will show the time of the location memory after you have stored it to a function key.

You can continue to press function keys to add location memory points. If you are recording a song, for example, you could run the tape from the beginning of the song and use the function key memories to mark the beginning of verses, choruses, instrumental breaks, etc. In post-production work, you could use this feature to mark important points in the video soundtrack.

- 4) **To use the function keys for their preset functions as written on the front panel, press SHIFT again so that the SHIFT indicator goes out.**

8.2.2 Editing function key memories

Function key memories can be edited in the same way as the MEMO 1 and MEMO 2 memories.

- 1) Go to menu group 7, move the cursor to `Loc (Func)`, and press **ENTER**:

```

Locate Position
(Function Key)

                                ABS
F. 1      10:04:23:15

```

- 2) Move the cursor to the function key number, and use the **UP** and **DOWN** keys to select the number of the function key memory that you want to change.
- 3) Use the **LEFT** and **RIGHT** keys to select the field (hours, minutes, seconds or frames) and use the **UP** and **DOWN** keys to change the value of the field.

There is an “invisible” field to the right of the number. Moving the cursor to this field and pressing the **UP** and **DOWN** keys will “fine-tune” the whole time value.

8.2.3 Locating to a function key memory

Once a location has been assigned to a function key, this is the procedure for location to the memory position:

- 1) Press the **SHIFT** key.
The **SHIFT** indicator will start to blink.
- 2) Press the function key corresponding to the memory to which you want to locate.
The display will show the location point and the pre-roll time, and the tape will start to locate to the appropriate location memory.
- 3) To use the function keys for their preset functions as written on the front panel, press **SHIFT** again so that the **SHIFT** indicator goes out.

8.2.4 Location and playback

If you press the **PLAY** key while the tape is locating (the **PLAY** key will flash), the tape will start playing when it reaches the location point.

If you press **PLAY** twice while the tape is locating, the **PLAY** key will light steadily, the tape will stop and playback will start immediately.

If you have pressed the **AUTO PLAY** key [12] before pressing the **SHIFT** key in step 1, (the **AUTO PLAY** indicator is on), replay will start automatically when the location point is reached.

8.2.5 Repeat function

You can repeat playback continuously between the two location memory points (`MEMO 1` and `MEMO 2`).

NOTE

When we talk about the “first” and the “second” locations here, we are referring to the earlier and later location times. `MEMO 1` could be at a later time than `MEMO 2`, and hence we would refer to it in this section as the “second location point”.

The tape will wind to a little before the first point (if it is not there already) and start playing. The off-tape monitoring will start at the first memory location and continue until the second location is reached. The tape will then stop playing, and rewind to a little before the first point and start playing again.

8.2.6 To start repeat play

- 1) When the two location points have been set, press the **REPEAT** key [21].
- 2) The tape will locate to the first location point and start playing until the second location point, rewind to the first location point, and play again. This process will be repeated.

While the tape position is between the two location points, the **REPEAT** indicator will be lit steadily. It will flash while the tape position is outside the two location points.

- 3) Stop the repeat function by pressing the **REPEAT** key.

The **REPEAT** indicator will go out.

If the tape is playing, it will continue playing (past the second location point).

Section 8 – Advanced operations

If the tape is rewinding to the first location point when the **REPEAT** key is pressed, it will stop.

NOTES

- The two location points must be at least 5 seconds apart for the repeat facility to be operational.
- If you have only set one location point, the repeat will be between “00:00:00:00” and the location point.
- Pressing any transport control while repeat play is in progress will stop the replay, but will not cancel the repeat mode. To restart the repeat playback, locate to either location point, and while the tape is winding, press **PLAY**. Alternatively, press **PLAY** while the tape is before the second location point.

8.3 Track delay

The DA-98 allows you to delay tracks relative to the other tracks, either when recording or playing back. You can use this function for post-production “slip”, compensate for delays caused by external processing equipment, allow for propagation delay in multi-microphone sessions or add special effects.

The track delay can be set from –200 samples to +7200 samples. A negative number means that the track on which the “delay” setting is made is advanced in time relative to the other tracks. However, this does not mean that the DA-98 includes a time machine! Since the monitoring head is a “virtual” head, made of a composite of delayed off-tape and input source signals, the “position” of the recording head can be adjusted in both directions.

The track delay, expressed in seconds, is between –4 to +150 milliseconds. At a typical sound propagation rate, the maximum value corresponds to about 50 meters (about 160 feet) of distance.

8.3.1 To set the track delay:

- 1) **Select menu group 0, and move the cursor to Delay. Press the ENTER key:**

```
Track Delay Time
-----
Track
1          00000 Sample
```

- 2) **To select the track whose delay time you want to change, move the cursor to the number at the bottom left of the screen and use the UP and DOWN keys to select the track.**

If the function keys are in number entry mode (see 5.2.2, “Using the function keys as number keys”), you can use keys **F 1** through **F 8** to select tracks 1 through 8 directly.

You can select tracks 1 through 8 or all (all) can be selected using function keys 9 or 10).

- 3) **By moving the cursor to the bottom right parameter (shown here as “Sample”), and using the UP and DOWN keys, you can display and set the track delay in either samples or milliseconds (ms).**
- 4) **Move the cursor to the central number. The UP and DOWN keys will change the delay value for the selected track(s).**

Remember that you can reset the value to zero by pressing and holding the **UP** key and then pressing the **DOWN** key. If “all” has been selected for the track, then all track delays will be reset to zero.

You can also use the function keys to enter the value directly, as described in 5.2.2, “Using the function keys as number keys”.

NOTE

When any track is set to be delayed, the **DELAY** indicator by the tape counter [2] will light.

8.4 Crossfade times

As we mentioned earlier (see 6.6, “Punch-in and punch-out”), digital punch recording requires that the original and new signal be crossfaded over a short period of time.

The factory default crossfade time for the DA-98 is 10 ms, and this can be adjusted in 10 millisecond steps to a maximum of 200 ms.

For the most part, 10ms is an adequate value and will produce seamless punches, but there may be times (matching reverb settings, etc.) when a longer crossfade is required.

- 1) Select menu group 1, move the cursor to `✕- Fade` and press **ENTER**.

```
Crossfade Time
          10ms
```

- 2) Use the **UP** and **DOWN** keys to adjust the crossfade time.

You can also use the function keys to enter the value directly, as described in 5.2.2, “Using the function keys as number keys”

8.5 Vari speed (pitch control)

The speed of recording and playback (and hence the pitch) of the DA-98 can be adjusted to 6% above or below normal speed in 0.1% steps.

NOTE

You cannot operate the pitch control when the DA-98 is slaved to another unit, or synchronized to an external word clock (see 4.2.3, “Word clock connections”) or to a video clock (see 4.2.2, “Video connections”).

8.5.1 To set a non-standard speed

- 1) Select menu group 0, move the cursor to `Vari Spd`, and press **ENTER**:

```
Vari Speed
          Fix + 0.0%
```

- 2) Use the **LEFT** and **RIGHT** keys to move the cursor by the left parameter (`Vari` or `Fix`).
- 3) Use the **UP** and **DOWN** keys to select `Vari` rather than `Fix`.
The **VARI SPEED** indicator by the tape counter [2] will light.
- 4) Move the cursor to the value setting and use the **UP** and **DOWN** keys to alter the speed in 0.1%

steps.

NOTES

- The **VARI SPEED** indicator by the tape counter [2] will light whenever the setting is `Vari`, even if the speed is set to `0.0%`.
- If pull up or pull down (`Fs` shift) is enabled (see 10.3.1, “Pull up and pull down (`Fs` shift)”, vari speed cannot be enabled.

Playback and recording will now take place at the new speed.

8.5.2 Resetting the speed to standard

- 1) Select menu 0, move the cursor to `Vari Spd`, and press **ENTER**:

```
Vari Speed
          Vari + 1.4%
```

- 2) Move the cursor to the `Vari` field.
- 3) Use the **UP** and **DOWN** keys to change `Vari` to `Fix`.

The **VARI SPEED** indicator by the tape counter [2] will go out.

NOTE

Remember that the **VARI SPEED** indicator reflects the status of the `Vari/Fix` parameter, not the value of the variable speed. If the speed is set to a value other than `0.0%`, and the status is `Fix`, the speed will remain at the standard value until `Fix` is changed to `Vari`.

8.6 Shuttle operations

The shuttle switch, indicator and knob [26] are used to simulate the “rock and roll” location method on open-reel tape decks, allowing you to locate a point on tape through audible cues.

As the knob is moved from the center detented position, the shuttle speed becomes higher.

The variation in speed is not continuous; but as you turn the knob from the center position, the shuttle speed changes, following these values (rel-

Section 8 – Advanced operations

ative to normal speed): 0.25, 0.5, 1.0, 2.0, 4.0, 8.0. The 1.0 speed is only available when shuttling in the forward direction.

Shuttle operations are only possible when the **SHUTTLE** indicator is lit (press the **SHUTTLE** switch).

NOTE

If the **SHUTTLE** knob remains untouched at the center position for 10 seconds, the shuttle mode is disabled, and the indicator goes off.

8.6.1 Shuttle monitoring

This is also covered in 7.1.3, “Shuttle monitoring”.

The default behavior of the DA-98 is that when shuttling the tape, you can choose whether to monitor off-tape or source when shuttling, using the tracks’ **INPUT MONITOR** switches.

NOTE

When monitoring in shuttle mode, the monitor signal is attenuated by 12 dB (to avoid possible damage to ears and speakers).

When **AUTO MON** [19] is on, the monitoring of any armed tracks will be off-tape, unless the **SHTL MON** [20] is on, in which case, the monitoring of armed tracks will be source input. The monitoring of all other (unarmed) tracks can still be switched on a track-by-track basis using the tracks’ **INPUT MONITOR** switches.

The **SHTL MON** key is only enabled when **AUTO MON** is on. When **AUTO MON** is off, it has no effect.

8.6.2 Shuttle muting

As explained above, shuttling the tape will usually allow off-tape monitoring. However, there may be times when you will want to mute all off-tape signals when shuttling.

- 1) Enter menu group 2, move the cursor to **Shttl Mute** and press **ENTER**:

```
Shuttle Mute
                                     off
```

- 2) Use the **UP** and **DOWN** keys to set the shuttle mute on or off.

8.7 Reference levels

The value of reference level (for analog inputs and outputs) on the DA-98 can be selected from among three standard values: TASCAM, SMPTE and European reference levels, depending on the application. The meanings of these three levels are:

Standard	Reference level (0dBFS)	Nominal level	Maximum level
TASCAM	-16dB	+4dBu	+20dBu
European	-18dB	+4dBu	+22dBu
SMPTE	-20dB	+4dBu	+24dBu

To set the reference level, perform the following steps:

- 1) Enter menu group 2, move the cursor to **Ref Level**, and press **ENTER**:

```
Analog In/Out
Reference Level
                                     -16 dB
```

- 2) Use the **UP** and **DOWN** keys to select between the following: -16dBFS, -18dBFS and -20dBFS.

The **REF LEVEL** indicators [7] will light in the following way to show the level selected:

Level	Indicators
-16 dB FS	16 indicator is lit
-18 dB FS	Neither indicator is lit
-20 dB FS	20 indicator is lit

NOTE

Any tapes produced with the TASCAM DA-88 or DA-38 will conform to the TASCAM standard.

8.8 Meter modes

The DA-98 peak bargraph meters can be customized to suit your working preferences. Both the peak hold time and the “ballistics” of the meters can be adjusted.

8.8.1 Peak hold time

- 1) Enter menu group 2, move the cursor to Meter Mode and press ENTER:

```

Level Meter Mode
Peak Hold      Release
0 sec          Fast
    
```

- 2) Use the LEFT and RIGHT keys to select the Peak Hold parameter and the UP and DOWN keys to set the value for the peak signal level hold time.

This value can be set to values between 0 seconds (peak levels are not held at all) and 9 seconds. There is another value, `Continue`, which will permanently display the maximum peak signal level. This can be useful if you are doing a “dry run” rehearsal, but you cannot keep your eyes on the meters all the time that the rehearsal is going on.

You can also use the function keys in the number key mode (see 5.2.2, “Using the function keys as number keys”) to enter the peak time directly.

NOTE

To turn off the peak hold display if `Continue` has been set, change the peak hold value to 0 seconds and the meter segments will “drop back”.

8.8.2 Meter ballistics

Use the same menu (`Level Meter Mode`) as described above to change the “fall-back” ballistics of the peak meters. You cannot change the rise time of the meters, which are fixed with peak meter characteristics.

- 1) Move the cursor to the `Release` parameter and use the UP and DOWN keys to select between `Slow`, `Medium` and `Fast`.

8.9 Sine oscillator

The DA-98 incorporates a digital oscillator for lineup and signal tracing purposes. This oscillator is a sine-wave oscillator at either the standard tuning frequency of 440Hz or the standard tape lineup frequency of 1kHz.

The oscillator signal level is at the nominal signal level of +4dBu (but note that since the oscillator is a constant sine wave, it cannot truly be compared with “real-world” transient signals).

To operate the oscillator:

- 1) Enter menu 2, move the cursor to `Sine Osc.` and press ENTER:

```

Sine Oscillator
off
    
```

- 2) Use the UP and DOWN keys to turn the oscillator between `off`, `440 Hz` and `1 kHz`.

When the oscillator is turned on, it overrides all other track inputs.

WARNING

When using the oscillator, you should turn down the monitor levels in the control room and studio to avoid damage to your ears (and the speakers).

8.9.1 Recording the oscillator

As mentioned above, the oscillator overrides all other track inputs, regardless of whether digital or analog input has been selected.

Recording the oscillator test tone is therefore similar to any other recording operation.

8.10 Digital recording

The DA-98 is able to accept (and output) digital signals at the **DIGITAL I/O** connector [45] in TDIF-1 format. The IF-88AE and IF-88SD interface units provide conversion to and from AES/EBU (and SP-DIF) and SDIF-2 formats.

The DA-98 should be connected to other TDIF-1 equipment using a PW-88D or PW-88DL connector cable.

WARNING

Only use a TASCAM digital cable when making digital audio connections to the DA-98. Other types of cable may cause damage to the system, and the warranty will be voided if such damage is caused by use of the wrong cables.

The DA-98 should be set to be either a word clock master or a word clock slave when connected to other digital equipment. There can only be one word clock master in a setup.

Since the TDIF-1 format carries a word clock as part of the interface, there is no need to make a word clock connection when recording through the **DIGITAL I/O** connector.

8.10.1 Changing between digital and analog inputs

To change between digital and analog inputs, simply press the **DIGITAL IN** switch [15]. The **DIGITAL IN** indicator will light.

NOTE

If you attempt to record digitally from a digital source which has a different frequency from that previously recorded as the DA-98's tape format, the Fs indicator corresponding to the tapes sampling frequency will start to flash. This indicates a frequency mismatch.

Recording with different sampling frequencies is not recommended – problems will certainly occur on replay of such a recording.

8.10.2 Selecting word length

When data is accepted through the **DIGITAL I/O** connector, the word length of the incoming data must be set. This can be selected from between 16-bit, 20-bit or 24-bit. To set the word length:

- 1) Select menu 2, move the cursor to `Word Len`, and press **ENTER**:

```
TDIF Word Length
                16 bit
```

- 2) Use the **UP** and **DOWN** keys to change the value between 16, 20 and 24 bits.

We suggest that you experiment with the dither settings (see 8.13, “Dither”) if you find you are recording quantization noise at low levels when the input word length is set to 20 or 24 bits.

Though you will lose a little in the signal-to-noise ratio, total harmonic distortion figures will be improved.

NOTE

If you are dubbing tracks from a DA-88, this value must always be set to 16 bits.

8.11 Routing digital inputs

When recording analog signals, it's usual to route them through a console's sub-grouping system or if the number of groups is not sufficient, through an external patchbay.

Neither of these is an easy option with digital signals, and so the DA-98 provides a kind of internal patchbay in the form of the Track Copy function (see 8.11.1, “Track Copy (channel-to-track routing”).

The default setting for this feature is “straight through”, as shown below.

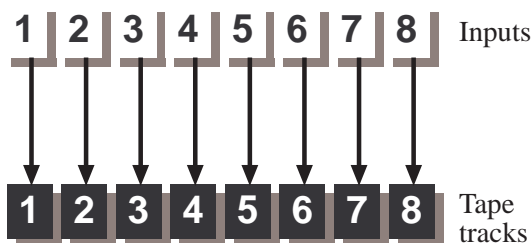

```
Track Copy
Input 12345678 (Dig)
Tape
Track 12345678 on
```

However, each track can be patched internally to take its input from any one of the eight inputs **or** from any one of the other tape tracks. Note that in the example below, it is possible for a track to act as an input source to another track at the same time that it is recording from an external input. This allows great flexibility in dubbing situations.

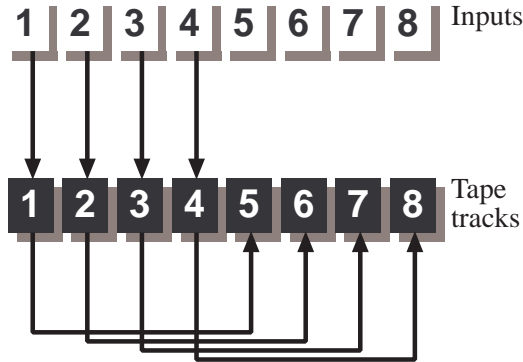

```
Track Copy
Input 1234 (Dig)
Tape 1234
Track 12345678 on
```

Naturally since the DA-98 tracks are digital, there is no loss of quality incurred when tracks are transferred.

NOTE

It is not possible to combine tracks (as in conventional “ping-pong”) using the Track Copy function. Combining of tracks must be carried out through an external mixing console. You can bounce a track to itself, but it is not a particularly meaningful process!

8.11.1 Track Copy (channel-to-track routing)

- 1) Select menu group 0, move the cursor to **Trk Copy** and press **ENTER**:

```
Track Copy
Input 12345678 (Ana)
Tape
Track 12345678 off
```

- 2) Use the **LEFT** and **RIGHT** keys to move the cursor to the **off** on the bottom line of the display and change it to **on**.

The **TRACK COPY** indicator will light.

- 3) Use the **LEFT** and **RIGHT** keys to move the cursor to the track you want to route.

You can also use the function keys as number keys for direct selection of the track (see 5.2.2, “Using the function keys as number keys”).

- 4) Use the **UP** and **DOWN** keys to change the track input between inputs 1 through 8 and tracks 1 through 8.

NOTE

If you change from analog to digital input (see 8.10.1, “Changing between digital and analog inputs”) or vice versa, the display will change between (Ana) and (Dig) as appropriate.

- 5) To re-route a track to its input, press and hold down the **UP** key and then press the **DOWN** key.

8.12 REC MUTE (recording silence)

There may be times when you wish to prevent any signal from reaching an armed track (in other words, when you record, you are recording silence onto the track).

- 1) Enter menu group 1, move the cursor to **Rec mute** and press **ENTER**:

```
Rec Mute
On
Off
trk 1 2 3 4 5 6 7 8
```

In the screen above, tracks 7 and 8 are muted (no input signal is routed to them).

- 2) Use the **LEFT** and **RIGHT** cursor keys to navigate between tracks. Use the **UP** and **DOWN** keys to switch the track muting of individual tracks on or off.

Pressing and holding the **UP** key and then pressing the **DOWN** key will reset the REC MUTE settings of all tracks.

8.13 Dither

Dither is the technique of adding a known noise to low-level signals, especially when converting from a high number of bits (for instance 24 or 20

input bits, as in the case of the DA-98) to a lower number (for instance 16, the DA-98's tape word length) to improve quantization.

Paradoxically, this technique of adding noise removes quantization noise and distortion at low signal levels and improves the overall distortion figures.¹

Though quantization noise is reduced, there is a loss of a few dB in the signal-to-noise ratio. For this reason, the DA-98 does not implement dither as a standard, but allows you to choose between no dither, rectangular or triangular (the shapes refer to the distribution of values in the digital noise). Rectangular gives about 3dB better signal-to-noise ratio than triangular, but there is noise modulation, which may be audible when recording and playing back low-level program sources.

NOTES

- We suggest using the confidence mode of off-tape monitoring when recording using dither in order to be able to check the effect instantly (see 7.2, "Confidence mode").
- Dither can be turned on and off while recording is taking place. However, there will probably be an audible change in the sound quality. We suggest making a test recording before a session using confidence mode. In this way you will be able to make an instant assessment of the effects of the different dither settings on your program material.

8.13.1 Selecting dither settings

- 1) **Select menu group 1, move the cursor to Dither and press ENTER.**

```
D i t h e r

Rectangular
```

- 2) **Use the UP and DOWN keys to select the dither function you want, and press ENTER to confirm the setting.**

¹ A full discussion of dither and other digital audio techniques is outside the scope of this manual. However, a good starting point for learning about this, and other aspects of digital audio, is John Watkinson's *The Art of Digital Audio*, pub Focal Press.

8.14 Setting the power-on message

You can set a power-on message of up to 20 characters (letters, numbers and some punctuation) which will be displayed when the DA-98 is turned on.

The default message is TASCAM. To set a message other than this:

- 1) **Select menu group 2, move the cursor to PwrOn Msg and press ENTER:**

```
Power-on Message

ROCKJOE STUDIOS

S CLEAR INIT
```

- 2) **To clear the current message, use the LEFT and RIGHT keys to move the cursor to CLEAR and press the ENTER key.**
- 3) **Use the LEFT and RIGHT keys to move the cursor to the left field, and press the UP and DOWN keys to select a character.**
Characters available are: A through Z, -, ., [space] and 1 through 9 (you can use the letter "0" for the "Ø" (zero) character).
- 4) **Press ENTER to confirm the character and add it to the end of the power-on message.**
- 5) **Press ESCAPE when all characters have been entered.**

NOTE

To reset the message to TASCAM, move the cursor to INIT and press the ENTER key. The current message will be erased and replaced.

9 – Synchronization with other DTRS units

This section describes the techniques and methods to be followed when the DA-98 is linked to other DTRS units (e.g. TASCAM DA-38, DA-88 and of course other DA-98 units).

Up to 16 DTRS units can be linked, for a total of 128 digital tracks.

If you are connecting DTRS units of different types to the DA-98, use the DA-98 as the master unit and the other units as slave units.

9.1 Synchronization connections

As described in 4.4.1, “Multiple DTRS units”, the cable to be used when connecting the DA-98 to other DTRS units for synchronization purposes should be a PW-88S cable. This is 1 meter (3 ft.) long. If you require a longer cable, please consult your TASCAM dealer.

WARNINGS

- Be sure to use only the optional PW-88S sync cables. The use of any other cables could damage the DA-98.
- Be sure to connect the termination plug that comes with the PW-88S cable to the last slave’s SYNC OUT connector [44], or else incorrect functions may occur.
- Turn on all the DTRS units in your system, regardless of whether you actually use all of them. A unit or units turned off will make synchronization impossible.
- To synchronize multiple DTRS units, use a pre-formatted tape in the master unit, and also in the slave units. Since the DTRS system uses ABS time to achieve synchronization, tapes without ABS time recorded on them make synchronization impossible.
- To synchronize multiple DTRS units, all the tapes in each unit must be formatted at the same sampling rate, or synchronization is impossible.

The synchronization connections form a “daisy-chain”, with the master unit at the head of the chain, and the last slave at the tail.

Connections are made from the **SYNC OUT** [44] of one unit to the **REMOTE IN/SYNC IN** [43] of the next.

You do not need to change the **CLOCK** setting

from **INT** [30] or to connect the **WORD SYNC** connectors [39].

WARNING

Always make and break all synchronization connections with the power to all units in the chain turned OFF.

9.2 Machine ID and master/slave settings

Each DTRS unit in the chain must be assigned a machine ID. The unit at the head of the chain (the master) should have ID number 1.

Though not strictly necessary, we suggest, that IDs are assigned in a consecutive sequential order from the head of the chain.

9.2.1 Differences between DTRS models

The DA-98 and DA-38 both use machine IDs that are set by software (the machine must be turned on for the ID to be set). The values for the IDs of these models start at “1” and go up to “16”.

The switch on the back of the DA-88 is only operative when the unit is turned off. It is marked from “0” through “F”.

When including DA-88s and DA-98s in the same chain, add 1 to the number shown on the DA-88’s rear panel machine ID switch to make the DA-88’s machine ID match the series of the DA-98 (and DA-38) IDs. Any DA-88 whose Machine ID is not 1 (the switch has been set to a value other than 0) will show its Slave ID briefly at power-on.

Therefore, for a chain of three units; a DA-98 as master, with a DA-88 and DA-38 as slaves, the machines’ IDs should be set as follows:

Unit	ID as shown	“Real” ID	How the ID is set	Power on or off when ID is set
DA-98	1	1	Menu system (see below)	ON
DA-88	1	2	Rotary switch on rear panel	OFF

Section 9 – Synchronization with other DTRS units

Unit	ID as shown	‘Real’ ID	How the ID is set	Power on or off when ID is set
DA-38	3	3	Tape counter menu system	ON

It therefore makes sense to set the machine IDs of all DA-88s in the chain first, immediately after connections have been made with the power off, and then turn on power to all units before setting the machine IDs of all DA-98s and DA-38s in the chain.

NOTE

When you set the machine IDs, you can set the ID of any machine first, but we recommend doing this in a standard sequence, working from the head of the chain to the end.

9.2.2 Setting machine ID

- 1) Select menu group 3, move the cursor to `Men ID`, and press **ENTER**:

```
Machine ID
          Machine 1
```

- 2) Use the **UP** and **DOWN** keys to select a value from 1 to 16.

NOTE

If you try to set the ID to a value other than 1 when the synchronization cable is not connected, the display will show an error message. Press **ESCAPE** to remove the message and continue.

9.2.3 Master/slave settings (CHASE mode)

Each unit with an ID greater than 1 is regarded as a slave unit.

- 1) On each slave unit, go to menu group 3, move the cursor to `TimeMode` and press **ENTER**:

```
Time Mode
          ABS
```

If the bottom line does not show `ABS` (if it shows `TC`), press the **UP** or **DOWN** key so that `ABS` is displayed.

- 2) On each slave unit, press the **CHASE** switch [16].

The **CHASE** indicator will start flashing.

- 3) Press any of the transport controls on the master unit (machine ID 1). The slave unit(s) will synchronize and follow the transport commands of the master.

When a slave unit is locked to the master unit, its **CHASE** indicator will light steadily.

- 4) To turn off chase mode on a slave unit, press the **CHASE** switch or the **STOP** key [34] so that the **CHASE** indicator goes off.

9.3 Machine offset

It is sometimes necessary to offset a unit in the chain relative to the master unit. This offset can be set to frame accuracy to a maximum value of $\pm 02:00:00:00$.

NOTE

This offset is unrelated to timecode offset and refers only to the machine offset when synchronized to other DTRS units.

9.3.1 Setting machine offset

- 1) Select menu group 3, move the cursor to `Men Offset`, and press **ENTER**:

```
Machine Offset
          +00:12:38:00  ABS
```

- 2) Use the **LEFT** and **RIGHT** keys to select the field to be edited (hours, minutes, seconds or frames) and the **UP** and **DOWN** keys to change the value of that field.

You can use the function keys as number keys (see 5.2.2, “Using the function keys as number keys”) to enter the value directly.

You can also change the sign of the offset value between + and - by moving the cursor to the sign.

- 3) Use the **ENTER** key to confirm the setting.

NOTE

There is an “invisible” field immediately to the right of the frames field. If you place the cursor there and increment or decrement the value, you can change the time as a whole (as the frame field passes its maximum value, the seconds field will increment).

9.3.2 Cancelling machine offset

To cancel machine offset, simply set the offset value to 00:00:00:00.

- 1) Press and hold down the **UP** key and press the **DOWN** key to reset the value in the **Machine Offset** menu (see above).

Machine offset will now be cancelled.

9.3.3 Setting machine offset “on the fly”

As well as entering an absolute number, it is also possible to enter a number “on the fly” as the tapes are playing.

- 1) On the slave machine, select menu group 3, move the cursor to **Mcn Offset**, and press **ENTER**.
- 2) Make sure chase mode (see 9.2.3, “Master/slave settings (CHASE mode)”) is off on the slave unit.
- 3) Use the **LEFT** and **RIGHT** keys to move the cursor to a second “invisible” field to the right of the frames field

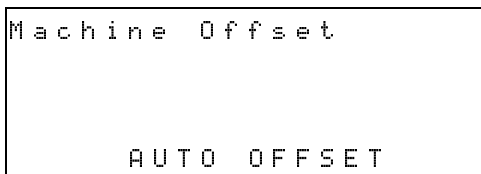

- 4) Locate the two tapes (master and slave) so that they have the right offset.

You can play the tapes and pause them or carry out the next operation while one or both tapes is being played back.

- 5) Press either the **UP** or **DOWN** key at the correct offset time to capture and store the offset.

The current difference between the master and slave tapes will be displayed on the bottom line of the display screen and stored as an offset.

NOTES

The value entered in this way can be edited later using the technique described above.

You cannot determine the offset from an unformatted tape, or if either tape is currently displaying a negative ABS value.

9.3.4 An example of setting offsets

A practical example of setting offsets is given here.

The master DA-98 contains the tape with the dialog and reference tracks from the video worktape. Another DA-98 (the slave) has a tape with some tracks containing video backing music. It is necessary to produce an offset between the two so that when the master is played, the music tracks will start at the correct time relative to the dialog and reference tracks.

Copy of video worktape audio tracks

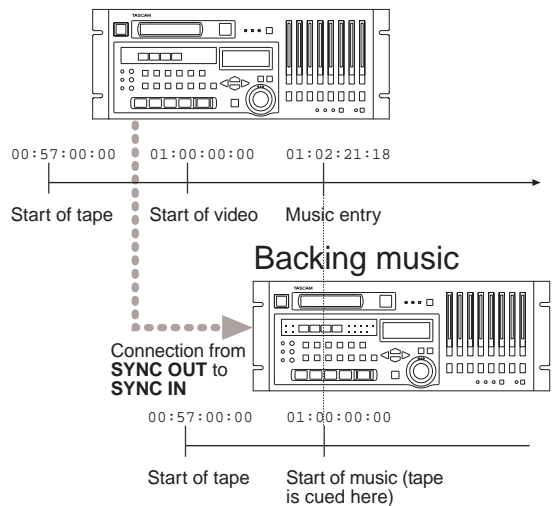

Press the **UP** or **DOWN** key at this point. Offset will be set to 00:02:21:18

Section 9 – Synchronization with other DTRS units

- 1) **Locate the slave tape with the backing music to the start of the music.**

The shuttle mode is useful here (see 8.6, “Shuttle operations”).

- 2) **Rewind the master to a little before you want the music to enter.**
- 3) **Make sure the slave is ready to accept an “on-the-fly” offset entry as described above.**
- 4) **Start playing the master DA-98.**
- 5) **When the music entry point is reached, press the UP or DOWN key to capture the offset point.**
- 6) **Stop the master, and set the slave into CHASE mode (see 9.2.3, “Master/slave settings (CHASE mode)”).**
- 7) **Rewind the master to a little before the music entry and start playing.**

The slave machine should now follow the transport movements of the master, with the appropriate offset, so that the music enters at the right point.

9.4 Digital dubbing

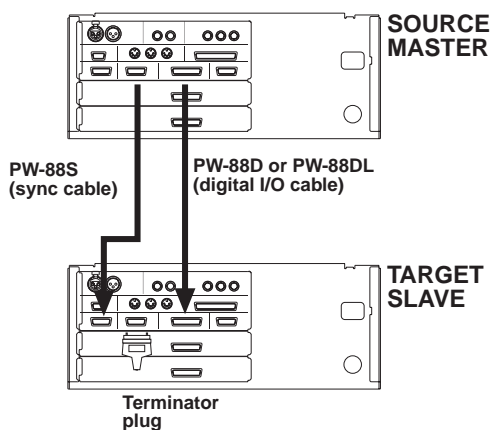

When you copy tapes between DTRS units in the digital domain, there is no loss of quality. A “worktape” or copy is therefore indistinguishable from the original. Additionally, the DA-98 uses low-cost media (Hi8 video cassettes).

NOTE

When you copy tracks from DA-88 units, the word length should be set to 16 bits (see 8.10.2, “Selecting word length”).

You may want to exploit these features of the DTRS system to make archive copies, and “safety copies” of important material (see 1.5, “Recommended tapes” for our suggestions on tape use).

- 1) **With the power to all units turned OFF, make the synchronization connections as described in 9.1, “Synchronization connections”.**

Remember to terminate the slave unit.

- 2) **Connect the DIGITAL I/O [45] of the master unit (source) to the DIGITAL I/O of the slave (target).**

Use only the approved cables (PW-88D or PW-88DL) to connect the DTRS units. Use of any other cables can cause damage to the units and will invalidate the warranties.

- 3) **Turn on both units. Make sure the machines’ IDs are correctly set (see 9.2.2, “Setting machine ID”).**
- 4) **Insert the master tape into the source master and a blank tape, formatted with the same sampling frequency as the master tape, into the target slave.**
- 5) **Select DIGITAL INPUT on the target slave (see 8.10.1, “Changing between digital and analog inputs”).**
- 6) **Put the target slave machine into CHASE mode (see 9.2.3, “Master/slave settings (CHASE mode)”).**
- 7) **Locate the master tape to a point before the material you want to duplicate.**

The target slave will also locate since it is in CHASE mode.
- 8) **Arm all tracks (REC FUNCTION) on the target slave machine.**
- 9) **Make sure that all REC FUNCTION switches on the source master are turned OFF.**

NOTE

If any **REC FUNCTION** switches on the source master are turned on, you will erase your master tape! You may want to use the tape’s write-protect tab (see 6.3.1, “Write-protecting cassettes”).

10) On the master machine, hold down RECORD and press PLAY.

No recording will take place on the source master, but the tracks will be recorded digitally on a one-to-one basis to the target slave.

There is no need to carry out any special pre-dubbing procedure such as timing the digital output – the digital and analog outputs are separate.

You can use the Track Copy functions on the target slave machine (see 8.11, “Routing digital inputs”) to transfer tracks from the source master tape to different tracks on the target slave. Note that you cannot combine tracks by this method.

9.4.1 Synchronized formatting

When several units are connected together, you can format several tapes simultaneously, using one machine as the master. This can be a very convenient way of saving time and effort.

- 1) **Make sure that all machines are connected together using the SYNC connections, as described above, and that the last unit in the chain is terminated.**
- 2) **Load a blank unformatted tape into each DTRS unit.**
Make sure all tapes are the same length.
- 3) **Press the CHASE switch [16] on all of the slave DTRS units. The indicator will flash.**
- 4) **Press FORMAT/Fs [6] twice within five seconds, on each of the DTRS units (master and all slaves) so that all FORMAT indicators are lit.**
The first time you press the FORMAT/Fs switch, the indicator will flash. Press it again within five seconds to select format mode. If you wait more than 5 seconds, the indicator will stop flashing.

If you press the **CLEAR** key [11] while the **FORMAT** indicator is lit steadily, you will cancel the format operation.
- 5) **Select the same sampling rate (48kHz or 44.1kHz) on each DTRS unit.**

Any slave DTRS unit which has a different sampling frequency selected from that selected on the master will display an error message.

- 6) **Press and hold PLAY and press RECORD on the master. All slave units’ CHASE indicators will light steadily, and the tapes will start to be formatted in synchronization.**

9.4.2 Recording while formatting

As with a single-machine format (see 6.1.2, “Recording while formatting”), it is possible to record while formatting.

You may want to use this feature when making a live multi-machine recording, and there has not been time to format all the tapes in advance of the performance.

Remember that you should let the tapes run to the end—you should not halt the formatting/recording process part of the way through the tape.

9.5 Error messages

These error messages refer to DTRS synchronization:

```
WARNING!
      TDIF(dubbing)cable
      not connected
```

Appears if the digital cable is not connected.. Reconnect the correct cable to the **DIGITAL I/O** connector.

```
WARNING!
No clock from MASTER
Check connections
and settings
```

Appears when the sync cable is not connected, the master has been turned off, or the master’s sampling frequency is different from that of the slave unit’s. Recheck these parameters.

If either of these messages appears, correct the fault, and press the **ESCAPE** key to return to normal operation.

Section 9 – Synchronization with other DTRS units

10 – Operations related to timecode

The DA-98 contains synchronization facilities, including a timecode generator, which allow it to act either as a timecode master or a timecode slave.

If timecode is recorded, a special discrete subcode track is used, which leaves all eight tracks free for recording and playback of audio material.

However, the DA-98 is able to synchronize with external timecode devices, even if the DA-98 tape has not been striped, by converting its internal servo subcode (ABS) to timecode “on-the-fly”.

A full range of options is provided for full compatibility with the widest possible range of other equipment.

10.1 ABS and SMPTE/EBU timecode

In some menus, by the time value, you may see either **ABS** or **TC**. Here, we explain these two different timing reference methods and the differences between them.

10.1.1 ABS time

“**ABS**” stands for “Absolute”, and is the absolute time of the tape as recorded on the subcode of the tape. This timing starts at the beginning of the tape with a value of 00:00:00:00. This is the timing reference used when the DA-98 is not using SMPTE/EBU timecode.

Timecode (whether SMPTE or EBU) contains a fixed number of frames per second. However, the ABS method of timing works in a slightly different way.

In three seconds of time, there are 100 frames. These frames are allocated as follows:

Second	Number of frames	Maximum frame value displayed
00 – 01	33	32
01 – 02	33	32
02 – 03	34	33

This pattern is repeated every three seconds, as you will notice when you set frame values using the menu system in ABS mode. When multiple DTRS units are connected together in DTRS sync mode, the master unit always outputs ABS timings to the slave unit(s).

10.1.2 Tape timecode

“**TC**” stands for timecode, and is shown whenever a SMPTE/EBU timecode value is used rather than the ABS value. The timecode may be internal or external and can be SMPTE/EBU, received and transmitted via the **TIME CODE IN/OUT** jacks [37], or SMPTE/EBU timecode synthesized from the ABS subcode (see 10.2, “Tape timecode mode”).

Whether the SMPTE/EBU timecode is generated or synthesized, we will refer to it as “timecode” in this manual, to distinguish it from ABS timing values.

SMPTE/EBU timecode can be re-produced independently of ABS timings and can be of any frame format supported by common timecode standards.

When multiple DTRS units are connected, and the master unit’s **CHASE** mode is set on, the master will chase to any incoming timecode, regardless of whether timecode or ABS timings have been selected as the time mode (see 10.1.3, “Selecting TC or ABS timing” below).

Timing information received and transmitted from and to external controllers (e.g. RS-422, MIDI or Bus) will always be referenced to timecode values.

When the DA-98 is referenced to its absolute timecode, the **ABS** indicator to the left of the tape counter [2] will light, and when referenced to timecode (internal or external), the **TC** indicator will light.

10.1.3 Selecting TC or ABS timing

NOTE

This procedure is fundamental to synchronization operations. If you select absolute timing mode when you want to synchronize with timecode, you will be unable to synchronize the DA-98.

Section 10 – Operations related to timecode

To change between the two different time reference modes, perform the following procedure:

- 1) **Select menu group 3 and press ENTER:**

```
Mc n ID      Ctrl Prt
Mc nOffset  Trk  Arm
TimeMode
          ABS
```

- 2) **Select Time Mode and press ENTER.**
- 3) **You can use the UP and DOWN keys to select either ABS (absolute) or TC (timecode).**

The appropriate indicator by the tape counter (either **ABS** or **TC**) will light.

10.1.4 Location point settings

NOTE

If you change an offset value (timecode or ABS), any punch points, location memories, etc. will be invalidated. For example, if you change the offset to 00:30:00:00 (30 minutes) from 00:00:00:00 (no offset), a punch point which was previously at 00:33:00:00 (33 minutes into the tape) will still have the same value (00:33:00:00), but will now be only 3 minutes into the tape.

10.2 Tape timecode mode

The following procedure allows you to select the source for tape timecode (including ABS timings used to synthesize SMPTE timecode. This synthesized timecode is treated exactly as if a tape had been striped with timecode).

- 1) **Go to menu group 5, move the cursor to TAPE TC, and press ENTER:**

```
Tape TC Mode
          Mode
          ABS
```

- 2) **Use the UP and DOWN keys to choose between the various options: TcTrack, ABS, ABS-Ofs, ABS-13 and ABS-23.**

These options are all described individually below.

10.2.1 TcTrack setting

This is the one setting in this menu which does not use the ABS conversion facility. You should only use this setting if you have already striped the dedicated timecode track with timecode (either from an external source or from the DA-98's own internal generator).

If you have selected **TcTrack** in the menu above, any timecode recorded on the tape will be used as the tape timecode source.

10.2.2 ABS setting

If you have selected **ABS** in the menu above, the ABS subcode time from the tape will be used as the timecode, with the start of the tape having a timecode value of 00:00:00:00, as with the ABS code itself.

The timecode frame rate used will be the frame rate as selected in 10.3, "Selecting the frame rate").

NOTE

If you are using ABS timings as timecode, the hours, minutes and seconds of the ABS time will correspond to the converted timecode, **unless** the frame rate is set to 29.97 non-drop or 30 drop. In these cases, the difference between ABS values and timecode values will be about 2 seconds per hour.

10.2.3 ABS-Ofs setting

As with the previous setting, this converts the ABS subcode timing to timecode, but allows you to add an offset to the absolute value so that the timecode does not start at the zero point.

When you select this option, the display will change to allow you to enter an offset time:

```
Tape TC Mode
Offset 30ND Mode
00:00:00:00 ABS-Ofs
```

- 1) Use the **LEFT** and **RIGHT** keys to choose the field to change (hours, minutes, seconds or frames) and then use the **UP** and **DOWN** keys to change the value of that field.

You can also enter a time offset directly using the function keys (see 5.2.2, “Using the function keys as number keys”).

The time you enter will then be the time at which the timecode starts from the beginning of the tape. For instance, if you enter an offset of 00:59:00:00, and the tape is positioned exactly 1 minute after the start, the timecode will be 01:00:00:00.

10.2.4 ABS-13 and ABS-23 settings

These settings are useful if you are recording many pieces on one tape. They automate the process of providing a timecode “pre-roll” and starting each piece at an easily-memorable timecode position.

The ABS-13 setting should be used to record pieces of 10 minutes or less in length, and the ABS-23 for pieces of 20 minutes or less.

With both of these settings, the start of the tape is automatically set with an offset of hh:57:00:00, where hh is the number of hours.

```

Tape TC Mode
Offset 30ND Mode
00:57:00:00 ABS-13
    
```

- 1) Use the **LEFT** and **RIGHT** keys to select the “hours” field.
- 2) Use the **UP** and **DOWN** keys to set the “hours” value.

Here we assume (for simplicity) that the “hours” value has been set to 00. If you set this to a different value, add the appropriate offset as you read this explanation.

Timecode is synthesized, starting at 00:57:00:00, allowing three minutes of timecode “pre-roll” before the nominal start of the piece at 01:00:00:00.

With ABS-13 selected, once the tape is positioned approximately 13 minutes from the start,

the timecode will restart at 01:57:00:00. If ABS-23 has been selected, this will occur approximately 23 minutes after the start of the tape (the piece is 20 minutes long). This allows another track to begin at 02:00:00:00.

This process continues until the end of the tape is reached. Wherever the tape is located, this calculation will be performed, allowing you to locate each track easily with reference to the timecode values.

The diagram below shows the relationship between the “synthesized” timecode and the absolute time on tape, assuming that the “hours” value has been set to 00.

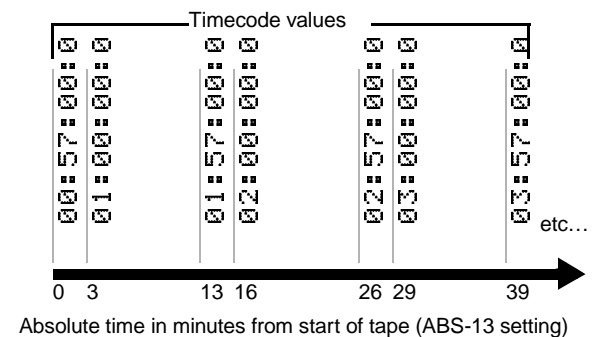

10.2.5 Checking tape TC

The TAPE TC indicator by the tape counter will light when timecode recorded on tape or synthesized from ABS is being read. The indicator will not light in areas of the tape where no timecode has been recorded if TCTrack has been selected, and will not light at the beginning or end of tape if any of the ABS modes has been selected. Timecode is not read in STOP mode and the indicator will not light in STOP mode.

As well as the tape counter, the display screen can also be used to show tape timecode values and the frame rate currently recorded on tape, as described below.

- 1) Go to menu group E, and move the cursor to TAPE TC:

```

Ext TC      Abs Diff
Tape TC     Rel Diff
Gen TC
01:02:48:17 30ND
    
```

Section 10 – Operations related to timecode

- 2) **Start playing the tape.**
- 3) **The selected timecode value will be displayed on the bottom line, together with the frame rate of the timecode.**

The frame rate displayed depends on the timecode frame rate as recorded on the tape (if `TC Track` has been selected) or on the selected frame rate (if another option has been chosen).

10.3 Selecting the frame rate

The DA-98 can use the following standards for timecode (including timecode synthesized by the ABS to TC facility): 30 non-drop, 30 drop, 29.97 non-drop, 29.97 drop, 25, and 24 frames per second (fps).

When using the DA-98 to chase to a timecode master, the system frame rate on the DA-98 must match the frame rate of the timecode master, otherwise chase operations are not possible.

The frame rate is automatically set when a tape which has been striped with timecode is inserted, or if power is switched on with a striped tape already inserted in the unit. The frame rate recorded on the tape will be used as the system frame rate.

To change the frame rate in other cases, follow the procedure below:

- 1) **Go to menu group 5, move the cursor to `TC Frame`, and press `ENTER`:**

```
TC Frame Mode
                29.97 NDF
```

- 2) **Use the `UP` and `DOWN` keys to select the frame rate for your project.**

10.3.1 Pull up and pull down (Fs shift)

When working in film post-production with NTSC telecine equipment, the frame rate of film (24 fps) and the NTSC color frame rate (29.97) do not form a simple mathematical ratio, and the sampling frequencies of either 44.1kHz and 48kHz are therefore affected on transfer back to film.

To avoid this, pull up and pull down functions are provided to adjust sampling frequencies to drop-frame rates, etc.

- 1) **Go to menu group 8, move the cursor to `Fs Shift`, and press `ENTER`:**

```
Fs Shift Mode
                off
```

- 2) **Use the `UP` and `DOWN` keys to select between `Pull Down 30NDF`, `Pull UP 29.97 NDF`, `Pull UP 29.97 DF`, `Pull Down 30DF` and `off`.**

The **PULL UP/DN** indicator by the tape counter [2] will light if the setting is anything other than `off`.

NOTES

- This setting is **not** memorized in the backup memory—you must reset it every time the DA-98 is turned off and on again.
- The clock source must be set to **INT** when using the `Fs` shift function to pull up, and to **VIDEO** when using this function to pull down.
- If vari speed is enabled (see 8.5, “Vari speed (pitch control)”, it is not possible to use the `Fs` shift function.
- When the `Fs` shift mode is operational, you cannot change the timecode frame rate (see 10.3, “Selecting the frame rate”).

10.4 Timecode input and output

Only timecode (not ABS timing) can be transmitted and received via the **TIME CODE IN** and **OUT** jacks. ABS timings are used for multiple DTRS unit synchronization.

10.4.1 Timecode input

There are two primary reasons for the DA-98 to receive timecode: when the DA-98 is chasing to timecode, and must receive the master timecode, and when the DA-98 is to record timecode from another unit (but see 10.5.5, “External timecode sources” below).

To view incoming timecode, follow the procedure below:

- 1) Go to menu group E, and move the cursor to Ext TC:

```

Ext TC      Abs Diff
Tape TC     Rel Diff
Gen TC
01:02:48:17  30ND

```

- 2) Incoming timecode will be displayed on the bottom line, together with the frame rate of the timecode.

The **EXT TC** indicator will light when timecode is received.

10.4.2 Timecode output

The timecode received at the **TIME CODE IN** jack, or the timecode recorded on tape, can be output from the **TIME CODE OUT** jack.

When the DA-98 is the timecode master, the timecode it outputs should be off tape.

However, when the DA-98 is in the middle of a timecode chain, you will probably want to retransmit the incoming timecode (the **OUT** functions as a **THRU**).

- 1) Go to menu group 5, move the cursor to OutTc Src (output timecode source), and press ENTER:

```

Output TC Source
External (regen)

```

- 2) Using the UP and DOWN keys, select one of the three options: **Tape**; timecode will be replayed off-tape, **External (regen)**; the external timecode will be re-generated by the DA-98's generator, resulting in a clean signal, or **External (reshape)**; the timecode

signal will be simply filtered before being re-transmitted.

NOTE

When the DA-98 is in CHASE mode, and the timecode output has been set to **TC Track** (see 10.2.1, "TcTrack setting"), the timecode output from the DA-98 will be the received timecode, with the offset value added or subtracted from it. This means that any other DTRS units slaved to the timecode output do not need to have separate offset settings, but can use the master DA-98's offset.

10.4.3 Timecode output format

This **Fast LTC** function controls the way in which timecode is output when fast winding the tape, or if shuttling is carried out at greater than normal playback speed.

The **5 Frame** setting means that timecode information is not output continuously. Here, the DA-98 reads the timecode from the tape as it is spooling, outputs 5 consecutive frames at normal speed starting with the value which has been read from tape, then reads the tape again, outputs another 5 consecutive frames based on the new tape position, and so on.

The **Leap** setting means that timecode is output continuously during fast operations, and will not be contiguous (it will leap between frames).

The **off** setting means that timecode is not output during fast operations.

- 1) Go to menu group 5, move the cursor to Fast LTC and press ENTER:

```

Fast LTC Mode
5 Frame

```

- 2) Use the UP or DOWN keys to select the option as described above.

10.4.4 Timecode output timing

Because of the nature of the digital-to-analog conversion, the timecode which is output from the DA-98 must be synchronized to match the audio timing from either the digital or the analog audio

- 2) Select timecode as the timing reference (see 10.1.3, “Selecting TC or ABS timing”).
- 3) Select a frame rate (see 10.3, “Selecting the frame rate”).
- 4) From menu group 8, move the cursor to **TcRec Src** (source for timecode recording) and press **ENTER**:

```

TC Record Source
-----
Generator TC
    
```

- 5) Use the **UP** and **DOWN** keys to select the source of the timecode as **Generator TC**.

The options here are **External TC** (received at **TIME CODE IN**), **Generator TC** (the internal generator) or the third option, which reflects the settings made in the **Tape TC Mode** menu (see 10.2, “Tape timecode mode”).

- 6) Go to menu group 8, move the cursor to **Gen Start** (generator start time) and press **ENTER**:

```

Generator Start Time
-----
00:00:00:00 30ND
    
```

- 7) Use the **LEFT** and **RIGHT** keys to select the field (hours, minutes, seconds or frames) to be edited, and the **UP** and **DOWN** keys to change the value.

You can also use the function keys as number keys to input the value directly, as described in 5.2.2, “Using the function keys as number keys”.

- 8) When you have finished setting the start time, press **ENTER**.

- 9) Go to menu group 8, move the cursor to **Gen Mode** (generator mode) and press **ENTER**:

```

Generate Mode
-----
00:55:00:00 30ND
Run/Stop Mode
Stop Reset
    
```

- 10) Press the **TC REC** switch [31].

The indicator will start flashing.

- 11) Now press the **UP** or **DOWN** key to start the timecode generator.

The **TC GEN** indicator by the tape counter will light.

- 12) Press and hold the **PLAY** and press the **RECORD** key and the tape will start recording.

The **TC REC** indicator will light steadily.

The display will change from **STOP** to **RUN**. Pressing the **UP** or **DOWN** key while the cursor is under this field will stop the generator.

You can also start recording and then start the timecode generator. In this case, an warning message will appear on the display screen as you start recording, to tell you that there is no timecode source.

If the **Mode** field is set to **Continue** rather than **Reset**, stopping the generator and then re-starting it will pick up the timecode values from where it left off.

Conversely, setting this field to **Reset** will restart from the start time set above every time the generator is stopped and re-started.

It is also possible to “drop into” timecode recording by starting the transport in record mode and then pressing the **TC REC** switch. However, we do not recommend this method of working, as it is impossible to check the timecode source prior to recording.

If the method described above (arming the timecode track, and then starting recording) is used, the tape counter is used to show the output from the timecode source (the generator) when the timecode track is armed, flashing when the tape is stopped, and steady when the tape is running.

Section 10 – Operations related to timecode

If there is no timecode source, the tape counter will show all hyphens while the timecode track is armed.

After starting the generator, you may want to make other settings, and will therefore have to change the display screen.

The tape counter shows the timecode from the generator, but you can use the following procedure to check the frame rate, especially in situations where you are using the output from the DA-98's generator to stripe another tape, etc.

- 1) Go to menu group E, and move the cursor to Gen TC:

```
Ext TC      Abs Diff
Tape TC     Rel Diff
Gen TC
01:05:12:23 30ND
```

- 2) The bottom line of the display screen will show the timecode values currently being output by the generator.

10.5.3 Synthesizing timecode from ABS timing

When you are synthesizing timecode from ABS, using any of the following options: ABS, ABS-Ofs, ABS-13 or ABS-23, as described in 10.2, "Tape timecode mode", the tape counter display behaves differently from the way as described above.

The tape counter will not flash when the timecode track is armed and the tape is stopped, and it will not display all hyphens, since the timecode source is always available.

In this case, you can start recording the timecode at any time (before or after) the tape has started moving.

10.5.4 Assembling timecode

You may want to use the assembly function when the first part of a tape contains timecode, and you want to stripe the rest of the tape with timecode that follows on seamlessly from the originally recorded timecode.

The assembly function reads a few seconds of timecode from tape and then uses this to jamsync the internal generator, which then stripes the rest of the tape.

- 1) Select TC Track from the Tape TC Mode menu (see 10.2.1, "TcTrack setting").
- 2) Go to menu group 8, move the cursor to TcRec Src (timecode record source) and press ENTER:

```
TC Record Source
Tape Assemble
```

- 3) Make sure the tape is rewound to a point which already contains timecode which can be used as the source for the rest of the tape.

- 4) Arm the timecode track (press TC REC so that the indicator is flashing).

The tape counter will show the last timecode read from tape as a flashing display.

- 5) Start playing the tape.

As timecode is read from the tape, the tape counter will show the values read from tape. If the tape does not contain timecode, the tape counter will show all hyphens.

- 6) Start recording when the tape counter is showing timecode (press the RECORD key).

The TC REC indicator will light steadily

Timecode will now be laid down in a continuous stream, starting at the current timecode value. The tape counter will display continuous timecode values.

It is also possible to press the TC REC key after starting audio recording.

10.5.5 External timecode sources

The following notes should help you when you must record timecode on the DA-98 from an external source (analog or digital). As mentioned earlier, though, you should only need to record timecode from an external source when the audio and timecode tracks have to be transferred

together, keeping a strict relationship between the audio and timecode tracks.

In all other cases, we suggest using either the DA-98's internal generator or timecode from tape. If you use these as sources, there will be no jitter problems, and any problems of synchronization with the digital audio clock are eliminated.

NOTE

When recording timecode from an external digital source, make sure the digital clock of the DA-98 and that of the external source are synchronized, as explained in 4.2.3, "Word clock connections" and 4.2.2, "Video connections". A warning message will appear if the timecode source and the DA-98 are not synchronized, but timecode can still be recorded. However, the resulting timecode recording will probably cause synchronization problems in the future.

When recording timecode from a timecode generator, make sure that there is a common video reference for both the DA-98 and the generator (set the **CLOCK** of the DA-98 to **VIDEO**).

When recording timecode from another DTRS unit, synchronize the two units using ABS chase (setting the timecode/audio source unit to be a slave unit as described in 9.2.3, "Master/slave settings (CHASE mode)"). After the two units have been synchronized in this way, timecode and audio can be transferred together.

When recording timecode from a digital source (audio or video), make sure that the DA-98 and the other unit are locked to a common word (audio recorder) or video (video recorder) clock reference. After the two machines have been synchronized in this way, timecode and audio can be transferred together.

When recording timecode from an analog recorder, feed the analog recorder or its external synchronizer and the DA-98 with a common video source, and use the video resolve function of the analog recorder or synchronizer, if this is provided.

If the analog recorder has no video resolve function, it may have a timecode chase function, which can be driven by any timecode source from the following list:

- timecode already recorded on an audio track of the DA-98
- timecode recorded on other DTRS units, using ABS chase with the DA-98
- timecode recorded on any other recorders synchronized with the DA-98
- a timecode generator, video-synchronized with the DA-98.

NOTE

Do not use any timecode recorded on the DA-98's dedicated subcode track as the timecode master when transferring timecode from an analog recorder.

If your analog recorder cannot chase to external timecode, you must first record the timecode from the analog recorder on an audio track of the DA-98 and then transfer the timecode to the dedicated timecode track.

Timecode recorded on the audio track in this way is synchronized to the audio clock, and can subsequently be transferred (through patching) to the timecode track.

10.5.6 Recording timecode from external sources

- 1) **Set the Time Mode to TC (see 10.1.3, "Selecting TC or ABS timing").**
- 2) **Set the timecode record source to External TC (see 10.5.1, "Selecting the timecode source").**
- 3) **Press the TC REC switch to arm the timecode track.**
- 4) **Start the external source to check the status of the external timecode.**

If no external timecode has been received since the DA-98 has been switched on, the tape counter will show all hyphens.

If external timecode has been received since the DA-98 has been switched on, but is not currently being received, the tape counter will flash.

If the external timecode is currently being received at normal (play) speed, the tape counter will show the value of the timecode currently being received. If the external timecode is being received from a

Section 10 – Operations related to timecode

source in fast wind mode, the tape counter will flash.

If the timecode source is not clock-synchronized with the DA-98, a warning will be shown on the display screen. In this case, although you can record timecode, it is not recommended, as this will probably cause problems later on.

5) Stop the external timecode source, and rewind or reset it to a point prior to where you want recording to begin.

The tape counter will now start to flash.

6) Restart the source.

The tape counter will display received timecode.

7) Press and hold down PLAY and press RECORD. Timecode will now be recorded from the external source onto the timecode track.

If the tape counter was flashing when the **TC REC** indicator was flashing (the timecode track was armed), the tape counter will now show all hyphens, and nothing will be recorded.

10.5.7 Checking external timecode

There is another way you can check external timecode, as described below. This method is useful for checking the frame rate of incoming timecode, if you are not sure what frame rate has been recorded or is being generated by the timecode source.

1) Go to menu group E, and move the cursor to Ext TC:

```
Ext TC      Abs Diff
Tape TC     Rel Diff
Gen TC
01:02:48:17 30ND
```

2) Incoming timecode will be displayed on the bottom line, together with the frame rate of the timecode.

10.6 Video resolution

As explained above, if the DA-98 is to be synchronized with a VTR, all units must share a common video reference for the digital audio clocks, generated either by the VTR or from a sync generator.

As well as the sample clock, the timecode can be referenced to a video clock (i.e. the start of each timecode frame is synchronized with each frame boundary received at the **VIDEO IN** terminal) or can be independent of the received frame clock.

Additionally, in a similar way to timecode rebase mode (page 10-13), the DA-98 can be set to rebase the video frame sync (muting playback output as it rebases), or to run freely once sync is achieved, ignoring any breaks in the received video signal.

1) Go to menu group 5, move the cursor to Vid Rslv (Video Resolve) and press ENTER:

```
Video Resolve
on/off      Mode
off         free
```

2) Use the LEFT and RIGHT keys to select the frame synchronization mode (on/off) and the UP and DOWN keys to toggle it on and off.

3) Use the LEFT and RIGHT keys to select the video rebase mode (either free or re-sync).

10.7 Chasing to timecode

The following sections describe the operation of the DA-98 when chasing to external timecode.

The operation of the **CHASE** switch is similar to the way the **CHASE** switch is used when synchronizing DTRS units (see 9.2.3, “Master/slave settings (CHASE mode)”), but in this case, the machine ID is not used.

10.7.1 Machine ID and timecode

Since a DA-98 with machine ID set to 1 is always a master unit as regards DTRS sync operation, there is no need to make any setting on such a machine if it is to be a timecode slave. As long as timecode is received at the **TIME CODE IN** connector [37] (the **EXT TC** indicator is lit), a unit whose machine ID is set to 1 will automatically enter timecode chase mode when the **CHASE** key is pressed.

However, when a DA-98 unit has its machine ID set to a value other than 1, there is a conflict when

the CHASE key is pressed. You must determine whether the chase mode refers to timecode or to the DTRS sync, and this is done using the Time Mode menu (see 10.1.3, “Selecting TC or ABS timing”). If **ABS** is selected, when **CHASE** is pressed, the machine will enter DTRS sync mode, but if **TC** is selected, the machine will attempt to lock to external timecode.

When the DA-98 is in “chase-ready” mode (the **CHASE** indicator is flashing) and timecode is received at the **TIME CODE IN** connector, the DA-98 will start to chase the timecode. When it is locked to the incoming timecode, the **CHASE** indicator will light steadily.

NOTES

- The timecode frame rate used on the DA-98 must match the frame rate of incoming timecode (see 10.3, “Selecting the frame rate”). If they do not match, a warning message will be shown, and the DA-98 will not chase to timecode. You can check the frame rate of incoming timecode (see 10.5.7, “Checking external timecode”) and of the timecode recorded on the DA-98’s tape (see 10.2.5, “Checking tape TC”)
- The timecode used internally by the DA-98 does not have to be an actual timecode striped tape. Instead, timecode can be “synthesized” from the ABS subcode timings, as described in 10.2, “Tape timecode mode”.

The exact ways in which it chases the timecode and handles transport functions, etc. are determined by a number of settings, as described below:

10.7.2 Setting timecode offset

You may enter a timecode offset for the audio from the DA-98 to match the audio (or video sequence) from the timecode master.

As with the machine offset (see 9.3.1, “Setting machine offset”), you can either set this manually, entering the numbers, or set it “on-the-fly” by ear. In either case, once the offset has been entered, it can then be edited.

The offset can be set to subframe accuracy (100 subframes = 1 frame).

10.7.3 Setting timecode offset from the menu

- 1) **Go to menu group 4, move the cursor to TC Offset and press ENTER:**

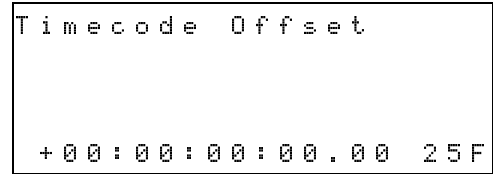

- 2) **Use the LEFT and RIGHT keys to select the field (hours, minutes, seconds, frames or subframes) and use the UP and DOWN keys to set the value.**

You can use the function keys in the number key mode (see 5.2.2, “Using the function keys as number keys”) to enter the offset (and the leading sign) directly.

If this value is set to anything other than 00:00:00:00.00, the **OFFSET** indicator by the tape counter will light.

If you move the cursor to the right digit of the subframe field, this will act as a “roll-over” field (i.e. if you are incrementing the value and it passes 99, the frame field will increment).

10.7.4 Cancelling timecode offset

When the timecode offset value is set to all zeros, timecode offset is cancelled and the **OFFSET** indicator goes out.

- 1) **From the Timecode Offset menu described above, press the UP and DOWN keys simultaneously to reset the value.**

10.7.5 Setting timecode offset on-the-fly

There is a second “invisible field” to the right of the subframe field (similar to that for machine offset settings – (page 9-3)). Moving the cursor to this field changes the display:

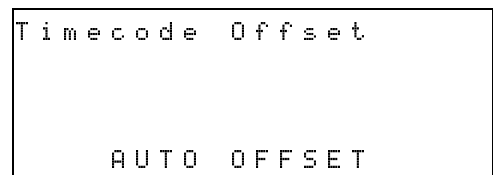

This screen allows you to set the offset by pressing the **UP** or the **DOWN** key. When you do this, the difference between incoming timecode and the

Section 10 – Operations related to timecode

internal timecode will be captured and stored as the timecode offset (either a positive or negative value).

Note that if the words `AUTO OFFSET` are not displayed on the screen, you cannot capture the offset value.

Once the offset value has been captured successfully, the display will change to show the captured offset value on the bottom line.

After the timecode offset has been entered in this way, you can “fine-tune” the value to subframe accuracy using the method described above.

10.7.6 Park position

When the DA-98 is slaved to an external timecode source, it will take some time between the master unit starting to play and starting to transmit timecode for the DA-98 to read.

These functions allow you to measure and test the optimum pre-roll position for the DA-98 (when it is a timecode slave) to park itself relative to the master timecode device so that it will lock up and start playing quickly.

- 1) **Go to menu group 4, move the cursor to Park Posi (park position) and press ENTER:**

```
Park Position
TEST
off      02s08f 25F
```

- 2) **The time value shows the current park setting, and this can be changed using the UP and DOWN keys, or the function keys.**

10.7.7 Automatic park position setting

When the DA-98 is acting as a timecode slave, it can automatically determine the optimum park pre-roll position to sync with the master.

- 1) **Go to menu group 4, move the cursor to Park Posi (park position) and press ENTER:**

```
Park Position
TEST
off      02s08f 25F
```

- 2) **Play and stop the master tape.**
- 3) **Turn the DA-98's CHASE on, if it is off.**
- 4) **Use the UP or DOWN keys to turn the TEST parameter on.**

The DA-98 will then rewind so that the relative difference is zero. When the DA-98 has stopped, go on to the next step below.

- 5) **Play the timecode master.**
When the value shown on screen has stopped changing and is stabilized, go on to the next step below.
- 6) **Turn TEST off (UP or DOWN key). The optimum park pre-roll time for the timecode master is now stored.**

10.7.8 Absolute and relative difference

The offset as set above (10.7.2, “Setting timecode offset”) can be called the “absolute difference” between the two times. However, if the slave machine “wanders” (actually, this is unlikely), the offset (theoretical difference) will not be equal to the absolute difference. The “relative difference” is expressed as below:

Relative difference = Absolute difference – Offset

Thus, if the offset is set on a slave machine to +00:10:00:00 (10 minutes) and while chasing, the two machines' counters read as follows:

Master	10:15:12:12
Slave	10:05:12:08

the slave is now 10 minutes and 4 frames behind the master.

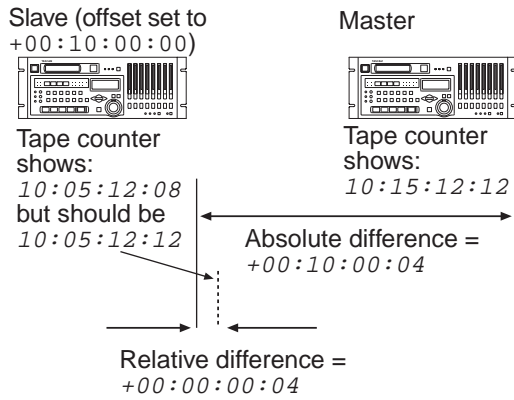

Since the slave is meant to be exactly 10 minutes behind the master, the difference, +4 frames, is the “relative difference” between the master and the slave.

To view the absolute and relative differences between master and slave machines:

- 1) Go to group menu E:

```

Ext TC      Abs Diff
Tape TC     Rel Diff
Gen TC
00:00:00:04      25F
    
```

- 2) Move the cursor to either Abs Diff (absolute difference) or Rel Diff (relative difference). The appropriate value will be shown on the bottom line of the display screen.

10.7.9 Rechasing timecode

When timecode is received, the DA-98 can either constantly monitor the internal off-tape timecode (or the ABS equivalent as set in 10.2, “Tape timecode mode”) and the external timecode, issuing “speed-up” and “slow-down” messages to the transport to keep itself in sync (rechasing), or it can synchronize once and run freely, ignoring the incoming timecode.

While the DA-98 is re-syncing (speeding up and slowing down), playback output will be muted, unless the clock is set to INT). Usually you should find that the DA-98 does not need to rebase, however, and you can leave it in free-running mode. If the timecode master tape includes a

break in the timecode, though, you may want the DA-98 to rebase the master.

As well as selecting rebase, you can also select the length of the “rebase window”. This means that if the difference between internal and incoming timecode is greater than the value of this window (1 or 2 seconds in the case of the DA-98), the synchronizer will start to rebase.

- 1) Go to menu group 4, move the cursor to Rechs Mod (rebase mode) and press ENTER:

```

Rebase Mode

Mode      Window
rebase    1 sec
    
```

- 2) Use the LEFT and RIGHT keys to select the Mode field, and the UP and DOWN keys to choose between rebase and free.
- 3) If you select rebase, use the RIGHT key to move to the Window field, and select a window of either 1 or 2 seconds.

10.7.10 Bypassing timecode errors

As timecode is received from a remote master unit, it may be subject to errors (dropouts on the timecode master tape, etc.). These errors can cause synchronization failure (the DA-98 will no longer be locked to the timecode of the master unit).

You can set the DA-98 to bypass and ignore incoming timecode errors of up to 30 frames in length, or up to 10 frames in length.

- 1) Go to menu group 4, move the cursor to ErrBypass (Error Bypass), and press ENTER:

```

Error Bypass

10 Frame
    
```

- 2) Use the UP and DOWN keys to select between 10 and 30 Frame.

11 – External control

The DA-98 can be controlled by other units, either through the **REMOTE IN/SYNC IN** TASCAM connector [43] as described in 9, “Synchronization with other DTRS units”, the 9-pin **RS-422** serial control connector [40], or through the **MIDI IN** connector [41] using MIDI Machine Control.

11.0.1 Selecting the control source (protocol)

- 1) Go to menu group 3, move the cursor to **Ctrl Prt (control protocol)** and press **ENTER**:

```
Control Protocol
          9Pin
```

- 2) Use the **UP** and **DOWN** keys to select between **9Pin**, **MIDI**, **Bus** and **off**.

These are all self-explanatory, except for the **Bus** setting, which refers to the sync/control bus carried through the **RS-422** connector [40]. An example of a device which can use this protocol is the TASCAM ES-61 editing controller.

NOTE

The selection of an external control protocol does not disable the local controls. When an external controller is selected, the last control pressed, whether local or remote, operates the DA-98.

11.1 Use with 9-pin external control

The RS-422 control allows the DA-98 to be controlled by a number of different editor/controllers, in the same way as a VTR or DAT.

11.1.1 Video clocking

If the DA-98 is to be controlled by a video editor, it is essential that the DA-98 and the controller receive identical video signals from the same source (a video generator, for example).

The DA-98 should also be set with video resolve set to **on**, either free-running or rebase (see 10.6, “Video resolution”).

The **CLOCK** switch of the DA-98 [30] should be pressed until the **VIDEO** indicator lights.

11.1.2 Emulation

The DA-98 is able to emulate a number of different units, so that when a Device-ID request is sent, the appropriate reply can be sent back in response.

- 1) Go to menu group 6, move the cursor to **Em1 Dev (Emulation Device)** and press **ENTER**:

```
Emulation Device
          PCM-7050
```

- 2) Use the **UP** and **DOWN** keys to select a device from the following list:

- PCM-7050
- BVH-3000
- BVU-950
- BVU-75
- PCM-800
- BVH-2000
- DUR-10
- TASCAM

- 3) Set your editor to control the device which is closest to the emulation you have just selected.

If the editor determines its controlling method from the reply to Device ID request, you should try using IDs starting from the top of the list.

If the editor recognizes “TASCAM” (and therefore bypasses video emulation) use the **TASCAM** emulation setting.

11.1.3 Record delay

Most recorders (both VTRs and audio recorders) drop into record a short time after they receive the command to start recording, and editor/controllers are programmed to take this into account.

However, the DA-98 starts recording immediately it receives the command. You can compensate for this using the Record Delay settings.

Section 11 – External control

- 1) Go to menu group 6, move the cursor to `Rec Dly` (Record Delay) and press **ENTER**:

```
Record Delay
          1 Frame
```

- 2) Use the **UP** and **DOWN** keys to select the record delay in frames.

This is the time that the DA-98 should delay between receiving a record command and actually starting to record.

This value can be between 0 and 9, or defaults to `Auto`. The value of the `Auto` setting depends on the emulation selected, as shown below:

Emulation	Frames
PCM-7050	3
BVH-3000	4
BVU-950	6
BVW-75	3
PCM-800	0
BVH-2000	4
DVR-10	5
TASCAM	0

The delay is calculated in the following way: the first frame boundary of the video signal received at the **VIDEO IN** after the record command is received is counted as "1". This number is incremented as subsequent frames are received, and when it equals the record delay value as set above, recording starts.

If the value is set to 0, recording starts instantly on receipt of the command, and if to 1, when the first frame edge is received.

If no correct video sync signals are being received, or if video sync mode is not enabled for some reason, internal data frame timing (every 30ms) is used instead.

This delay is also used for controlling the timing of the monitor switching.

11.1.4 Cue-up tally

When a locate command is received while the DA-98 is in 9-pin protocol mode, the transport

locates to the desired position, and then goes into pause mode.

What is then returned to the controller depends on the following setting:

- 1) Go to menu group 6, move the cursor to `Cueup Tly` (cue-up tally), and press **ENTER**:

```
Cueup Tally
          Stop
```

- 2) Use the **UP** and **DOWN** keys to select between `Stop` and `Still`.

Some controllers will only take their next action when they know that the controlled slaves are stopped. Select the `Stop` value for use with these controllers.

Other controllers (e.g. the LYNX II and MicroLynx synchronizers) make a distinction between pause and stop. When using such synchronizers, select the `Still` value.

11.1.5 Fast wind speed

There are two basic methods for locating used by controllers. The first method is to send a locate command. The second is to send fast wind and shuttle commands.

If the usual high speed winding of the DA-98 is used with the second method, the tape will almost invariably overshoot each time and never come to rest. For that reason, you can select between the fast wind modes (at 100 times play speed) and fast shuttle (8 times play speed) depending on the method used by your controller.

- 1) Go to menu group 6, move the cursor to `Fast Spd` (fast wind speed) and press **ENTER**:

```
Fast Wind Speed
          x 100
```

- 2) Use the UP and DOWN keys to select between 100 and 8.

To determine whether your controller is sending (a) locate commands or (b) fast wind commands, enter a locate operation from the remote controller.

If a true location command is being sent, the screen display will show the location point for a few seconds and only the fast forward and rewind keys will light. If the second type of command is received, the display will not change, and the fast forward and rewind indicators will light steadily, and the SHUTTLE indicator will flash.

11.1.6 Track mapping

When a controller arms and records on tracks, you need to specify which tracks on the controller correspond to particular tracks on the DA-98. The video controller protocol allows for control of up to eight digital and four analog audio tracks. The setting described here allows you to map controller tracks to DA-98 tracks.

This mapping does not imply any correspondence between the user interface of the controller and the DA-98 tracks—it refers to the relationship between the command signals transmitted by the controller and the DA-98 tracks. The relationship between the user interface of the controller and the command signals must be determined using the controller itself.

- 1) Go to menu group 6, move the cursor to Trk MAP (track mapping) and press ENTER:

Track Mapping								
Ana	1	2	3	4				
Dig					1	2	3	4
Trk	1	2	3	4	5	6	7	8

The lines above show the analog and digital tracks to which the DA-98 tracks on the bottom line are currently assigned.

The terms “analog” and “digital” used here have nothing to do with whether tracks actually are analog or digital. They correspond to the “Analog” and “Digital” tracks which the controller uses.

In the assignment above, therefore, when the controller refers to analog track 3, it is actually

addressing DA-98 track3, and when referring to digital track 4, it is addressing DA-98 track 8.

- 2) Use the UP and DOWN keys to select the track mapping for use with your setup. The pre-set options available are shown below:

DA-98 track =>	1	2	3	4	5	6	7	8
Analog	1	2	3	4				
Digital					1	2	3	4
Analog								
Digital	1	2	3	4	5	6	7	8
Analog	1	2	3	4	1	2	3	4
Digital								
Analog	1	1	2	2	3	3	4	4
Digital								
Analog								
Digital	1	2	3	4	1	2	3	4
Analog								
Digital	1	1	2	2	3	3	4	4

There are no user-settable track mappings, but the pre-set mappings are designed to cover every circumstance.

11.1.7 Timecode track mapping

This is a special instance of track mapping, where the track corresponding to analog track 3 in the controller’s command signals is mapped either to the digital audio track selected above (11.1.6, “Track mapping”), or to the DA-98’s dedicated timecode track.

- 1) Go to menu group 6, move the cursor to TC Rec EN and press ENTER:

TC Record Enable
disable

Section 11 – External control

- 2) Use the **UP** and **DOWN** keys to select between `enable` and `disable`.

If you choose `disable`, the track referred to by the controller's command signals as "analog 3" will be the audio track designated as "analog 3" in the `Track Mapping` menu above. If you choose `enable`, the DA-98's timecode track will be mapped to the track referred to by the controller's command signals as "analog 3".

11.1.8 Remote track arming

You may sometimes want to disable the arming of tracks from the remote system (either TASCAM bus, MIDI or 9-pin).

Since many video editors, etc. only provide for the control of four tracks, this means that you cannot control the eight tracks of the DA-98 from the editor, and so remote track arming should be disabled, allowing you to control the tracks locally.

- 1) Go to menu group 3, move the cursor to `Trk Arm`, and press **ENTER**:

```
Remote Track Arming
                               enable
```

- 2) Use the **UP** and **DOWN** keys to select between `enable` and `disable`.

11.2 Bus protocol

If Bus protocol is selected (see 11.0.1, "Selecting the control source (protocol)"), the DA-98 can be controlled by controllers such as the TASCAM ES-61.

Each DA-98 must be assigned a unique number between 1 and 127, as described below.

11.2.1 Assigning a MIDI and Bus ID to the DA-98

A MIDI ID is used in a MIDI Machine Control setup to identify each unit in the MIDI chain. The same number is also used as a Bus identifier.

One (and only one) of up to 127 units can be designated as the MIDI Timecode Master for the whole chain.

This MIDI ID is not the same as a MIDI Channel number (even though some units' manuals may refer to it as a "channel number"), and is not connected with the Machine ID (see 9.2, "Machine ID and master/slave settings"). To set the MIDI ID:

- 1) Go to menu group 7, move the cursor to `MIDI ID`, and press **ENTER**:

```
MIDI/Bus ID
                               001
```

- 2) Use the **UP** and **DOWN** keys to select a value between `001` and `127`, making sure that this ID is unique in your setup.

You can also use the function keys as number keys (see 5.2.2, "Using the function keys as number keys") to enter the MIDI ID directly.

You can also select the value `Receive All`, which allows the DA-98 to accept all MMC commands transmitted over the MIDI network (this setting has no effect if Bus is selected).

11.3 MIDI Machine Control

As well as control from the 9-pin RS-422 port, the DA-98 can also accept commands received at the **MIDI IN** port (page 3-1) using the MIDI Machine Control protocol.

Set the MIDI ID using the method described immediately above.

The MMC commands used by the DA-98 are listed in see 15, "Options, specifications and reference".

The control source must be set to `MIDI` (see 11.0.1, "Selecting the control source (protocol)") for this to be effective.

The implementation of the MIDI Machine Control protocol and the commands which are available are described in 15.3, "MMC Bit Map Array".

11.3.1 MMC commands and the DA-98

An example of a MIDI sequencer being used to control a DA-98 (using the auto-punch of the sequencer to punch in and out on the DA-98

tracks) is given below. Note that the sequencing software must be able to transmit MMC commands and also to sync to MTC for this to be effective:

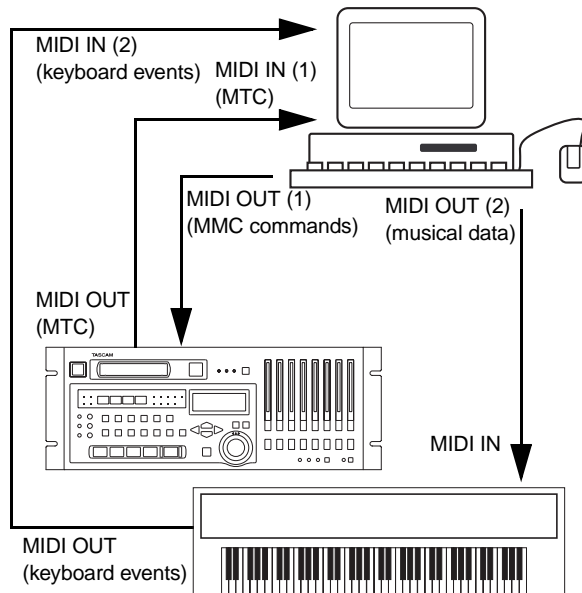

The sequencer is set up to transmit MMC commands, and is set so that it synchronizes to SMPTE/MTC.

When a “transport” command is given from the sequencer, the appropriate MMC command is transmitted to the DA-98. When the DA-98 has located and starts playback (or recording), the MTC is transmitted back to the sequencer, which locks in and starts at the correct point.

In this way, though the DA-98 is the timecode master, the sequencer is the transport master.

The arrangement shown here uses 2 inputs to the sequencer. The same effect could be achieved with the intelligent use of filtering mechanisms.

12 – Menu and parameter reference

12.1 Menu groups

This section provides a quick guide to the menus and their functions, providing a list of menus in each menu group, the parameters available in each menu, and the values that each parameter can take (default values are underlined). There is also, wherever appropriate, a reference to the section of the manual which describes the function.

Please note the 12.2, “Menu item index” which provides an alphabetically-sorted list of menu functions.

12.1.1 Menu group 0

<pre> Delay Memo 1 Trk Copy Memo 2 Vari Spd Loc Pre </pre>			
Menu item	Parameter(s)	Values	Reference
Track Delay Time	Track Delay time Unit	<u>1</u> through 8, All -200 through 7200 (samples) - 4 through 150 (msec) - default <u>0</u> <u>sample, msec</u>	8.3, “Track delay”
Track Copy	Track source Enabled	Input (digital or analog) 1 through 8 or track 1 through 8. Default is straight-through input to tracks assignment Turns track copy operations <u>on</u> or <u>off</u>	8.11.1, “Track Copy (channel-to-track routing)”
Vari Speed	Enabled Amount	<u>Fix, Vari</u> -6.0% through +6.0% (default is <u>0.0%</u>)	8.5, “Vari speed (pitch control)”
Memo 1	Time value	Defaults to <u>00:00:00:00</u>	8.1, “Autolocation”
Memo 2			
Locate Pre-roll	Minutes and seconds	<u>00min00sec</u> through <u>59min59sec</u>	8.1.3, “Setting the location pre-roll time”

Section 12 – Menu and parameter reference

12.1.2 Menu group 1

<pre>In Point X-Fade Out Point Dither Pre/Post Rec Mute</pre>			
Menu item	Parameter(s)	Values	Reference
Punch-in Point	Time value	Defaults to <u>00:00:00:00</u>	6.6, “Punch-in and punch-out”
Punch-out point			
Pre-roll Post-roll	Pre-roll time Post-roll time	<u>00m05s</u> through 59m59s <u>00m03s</u> through 59m59s	6.6.4, “Editing the pre-roll and post-roll times”
Crossfade Time	Milliseconds	<u>10 ms</u> through 200 ms in 10 ms steps	8.4, “Crossfade times”
Dither	Type of dither	<u>off</u> , Rectangular, Triangular	8.13, “Dither”
Rec Mute	Track muting	On or <u>off</u> for each track	8.12, “REC MUTE (recording silence)”

12.1.3 Menu group 2

<pre>Sht1 Mute MeterMode Word Len Sine Osc. Ref Level PwrOn Msg</pre>			
Menu item	Parameter(s)	Values	Reference
Shuttle Mute	Enabled	<u>off</u> or on	8.6.2, “Shuttle muting”
TDIF Word Length	Length in bits of incoming data	<u>16 bit</u> , 20 bit, 24 bit	8.10.2, “Selecting word length”
Analog In/Out Reference Level	Reference level in dB	<u>-16dB</u> , -18dB, -20dB	8.7, “Reference levels”
Level Meter Mode	Hold time Release rate	0 to 9 seconds or <u>Continue</u> (default 1) <u>Slow</u> , <u>Fast</u> , <u>Medium</u>	8.8, “Meter modes”
Sine Oscillator	Enabled	<u>off</u> , 440 Hz, 1 k Hz	8.9, “Sine oscillator”
Power-on Message	Up to 20 alphanumeric characters	If INIT is selected, defaults to TASCAM. CLEAR clears all entered characters. A through Z, 1 through 9, -, . and space may be entered	8.14, “Setting the power-on message”

12.1.4 Menu group 3

<pre> Mcn ID Ctrl Prt McnOffset Trk Arm TimeMode </pre>			
Menu item	Parameter(s)	Values	Reference
Machine ID	Machine ID for synchronization	1 through 16	9.2.2, “Setting machine ID”
Machine Offset	Time value to frame accuracy	Defaults to <u>+00:00:00:00</u> <u>± 02:00:00:00</u>	9.3.1, “Setting machine offset”
Time Mode	Time reference	<u>ABS</u> , TC	10.1.3, “Selecting TC or ABS timing”
Control Protocol	Type	<u>9Pin</u> , MIDI, Bus, off	11.0.1, “Selecting the control source (protocol)”
Remote Track Arming	Enabled	<u>enable</u> , disable	11.1.8, “Remote track arming”

12.1.5 Menu group 4

<pre> TcChs Rec TC Offset RechMode Park Posi ErrBypass </pre>			
Menu item	Parameter(s)	Values	Reference
TC Chase Individ. Rec	Enabled	<u>enable</u> , disable	10.7.11, “Individual recording while chasing timecode”
Rechase mode	Mode Window	<u>rechase</u> , free <u>1 sec</u> , 2 sec	10.7.9, “Rechasing timecode”
Error Bypass	Time in frames	<u>10 Frame</u> , 30 Frame	10.7.10, “Bypassing timecode errors”
Timecode Offset	Time to sub-frame accuracy	Defaults to <u>+00:00:00:00.00</u> <u>±12:00:00:00.00</u>	10.7.2, “Setting timecode offset”
Park Position	Test Manual entry	<u>off</u> , on <u>00s00f</u> through 2 seconds minus 1 frame	10.7.6, “Park position”

Section 12 – Menu and parameter reference

12.1.6 Menu group 5

Menu item	Parameter(s)	Values	Reference
TC Frame Mode	Frame Rate	30 DF, 30 NDF, 29.97 DF, 29.97 NDF, 25 F, 24 F	10.3, “Selecting the frame rate”
Output TC Timing	Output reference	Analog, Digital	10.4.4, “Timecode output timing”
Output TC Source	Source of timecode output	TAPE (ABS or IC Track), External (regen), External (reshape)	10.4.2, “Timecode output”
Fast LTC Mode	Linear timecode in fast wind	05 Frame, Leap, off	10.4.3, “Timecode output format”
Video Resolve	Enabled Mode	on, off free, re-sync	10.6, “Video resolution”
Tape TC Mode	Mode	IC Track, ABS, ABS-Ofs ^a , ABS-13, ABS-23	10.2, “Tape timecode mode”

a. If the ABS-Ofs (Absolute timing with offset) option is selected, the bottom line of the display changes to allow direct entry of the desired offset value.

12.1.7 Menu group 6

<pre> Em1 Dev TC Rec EN Rec Dly Fast Spd Trk Map Cueup Tly </pre>			
Menu item	Parameter(s)	Values	Reference
Emulation Device	Device name	PCM-7050, BVH-3000, BVU-950, BVW-75, PCM-800, BVH-2000, DUR-10, TASCAM	11.1.2, “Emulation”
Record Delay	Time in frames	0 through 9 frames or <u>Auto</u> (the number of frames depends on the selected emulation)	11.1.3, “Record delay”
Track Mapping	Track maps	Various mappings of DA-98 tracks to analog/digital. Default is DA-98 tracks 1 through 4 correspond to analog tracks 1 through 4 and DA-98 tracks 5 through 8 correspond to digital tracks 1 through 4.	11.1.6, “Track mapping”
TC Record Enable	Enabled	<u>disable</u> , <u>enable</u>	11.1.7, “Timecode track mapping”
Fast Wind Speed	Referenced to play speed	<u>x 100</u> , <u>x 8</u>	11.1.5, “Fast wind speed”
Cueup Tally	Message to remote	<u>Stop</u> , <u>Still</u>	11.1.4, “Cue-up tally”

12.1.8 Menu group 7

<pre> MTC Out MIDI ID FunctMode Loc(Func) </pre>			
Menu item	Parameter(s)	Values	Reference
MTC Output	Output Fast wind mode Stop	<u>on</u> , <u>off</u> <u>on</u> , <u>off</u> <u>on</u> , <u>off</u>	10.4.5, “Using MIDI Time Code (MTC)”
Function Key Mode Select	Mode for function keys	<u>Menu</u> , <u>Locate Position</u> , <u>10 Key</u>	5.2, “Function key modes”
MIDI/Bus ID	MIDI ID for MMC	001 through 127, <u>Receive All</u>	11.2.1, “Assigning a MIDI and Bus ID to the DA-98”
Locate Position (Function Key)	Enabled Function key Time value	<u>off</u> (if function key mode is “Locate Position”, location point is displayed. If the function key mode is not “Locate Position”, <u>off</u> is displayed) <u>F. 1</u> through <u>F. 10</u> Defaults to 00:00:00:00	8.2.2, “Editing function key memories”

Section 12 – Menu and parameter reference

12.1.9 Menu group 8

<pre> Gen Start Fs Shift Gen Mode TcRec Src </pre>			
Menu item	Parameter(s)	Values	Reference
Generate Start Time	Time value	Defaults to <u>00:00:00:00</u>	10.5.2, “Recording timecode using the generator”
Generate Mode	Run/Stop Mode	<u>Stop</u> , Run <u>Reset</u> , Continue	10.5.2, “Recording timecode using the generator”
Fs Shift Mode	Pull up/down parameters	<u>off</u> , Pull Down 30NDF, Pull Up 29.97NDF, Pull Up 29.97 DF, Pull Down 30DF	10.3.1, “Pull up and pull down (Fs shift)”
TC Record Source	Timecode source	<u>External TC</u> , Generator TC, Tape ^a	10.5.1, “Selecting the timecode source”

a. If Tape is selected, there will be another parameter automatically appended. This parameter will be Assemble, ABS, ABS/Offset, ABS/Auto13 or ABS/Auto23 depending on the setting made in the Tape TC Mode menu (page 12-4).

12.1.10 Menu group 9

<pre> Cleaning Setup BER Disp </pre>			
Menu item	Parameter(s)	Values	Reference
Cleaning Mode	on/off Counter	<u>off</u> , on Automatically incremented	14.1.1, “To clean the heads and transport”
Block Error Rate	Tape area	<u>Tape Edge</u> , Tape Center	14.1.2, “Checking error rates”
Setup	Setup memories Load/Save	1, 2, 3 and F (factory) Load, Save	14.3.1, “Saving user setups”

12.1.11 Menu group E

<pre>Ext TC Abs Diff Tape TC Rel Diff Gen TC</pre>			
Menu item	Parameter(s)	Values	Reference
Ext TC	There are no user-settable values in this menu. Moving the cursor to the menu item will display the relevant value on the bottom line of the display.		10, "Operations related to timecode"
Tape TC			
Gen TC			
Abs Diff			10.7.8, "Absolute and relative difference"
Rel Diff			

12.1.12 Menu group F

<pre>Sys Ver Front Ver Servo Ver Sync Ver Dr Total Dr Search</pre>			
Menu item	Parameter(s)	Values	Reference
Sys Ver	There are no user-settable values in this menu. Moving the cursor to the menu item will display the relevant value on the bottom line of the display.		14.4, "Checking version numbers"
Front Ver			
Servo Ver			
Sync Ver			
Dr Total			14.1.3, "Checking head time"
Dr Search			

Section 12 – Menu and parameter reference

12.2 Menu item index

Use this alphabetical list when you want to find out quickly to which menu group a menu item belongs.

Menu Item	Menu group	Menu Item	Menu group
Abs Diff	E	Park Position	4
Analog In/Out Reference Level	2	Power-on Message	2
Block Error Rate	9	Pre-roll Post-roll	1
Cleaning Mode	9	Punch-in Point	1
Control Protocol	3	Punch-out point	1
Crossfade Time	1	Rechase mode	4
Cueup Tally	6	Record Delay	6
Dither	1	Record Mute	1
Dr Search	F	Rel Diff	E
Dr Total	F	Remote Track Arming	3
Emulation Device	6	Servo Ver	F
Error Bypass	4	Setup	9
Ext TC	E	Shuttle Mute	2
Fast LTC Mode	5	Sine Oscillator	2
Fast Wind Speed	6	Sync Ver	F
Front Ver	F	Sys Ver	F
Fs Shift Mode	8	Tape TC	E
Function Key Mode Select	7	Tape TC Mode	5
Gen TC	E	Tc Chase Individ. Rec	4
Generate Mode	8	TC Frame Mode	5
Generate Start Time	8	TC Record Enable	6
Level Meter Mode	2	TC Record Source	8
Locate Position (Function Key)	7	TDIF Word Length	2
Locate Pre-roll	0	Time Mode	3
Machine ID	3	Timecode Offset	4
Machine Offset	3	Track Copy	0
Memo 1 & Memo 2	0	Track Delay Time	0
MIDI/Bus ID	7	Track Mapping	6
MTC Output	7	Vari Speed	0
Output TC Source	5	Video Resolve	5
Output TC Timing	5		

13 – Example setups

This section gives a few examples of how the DA-98 might be used in real-world situations together with other equipment.

13.1 An all-DA-98 setup

In this example, a small audio studio offers its clients 24 digital tracks by using three DA-98s synchronized together.

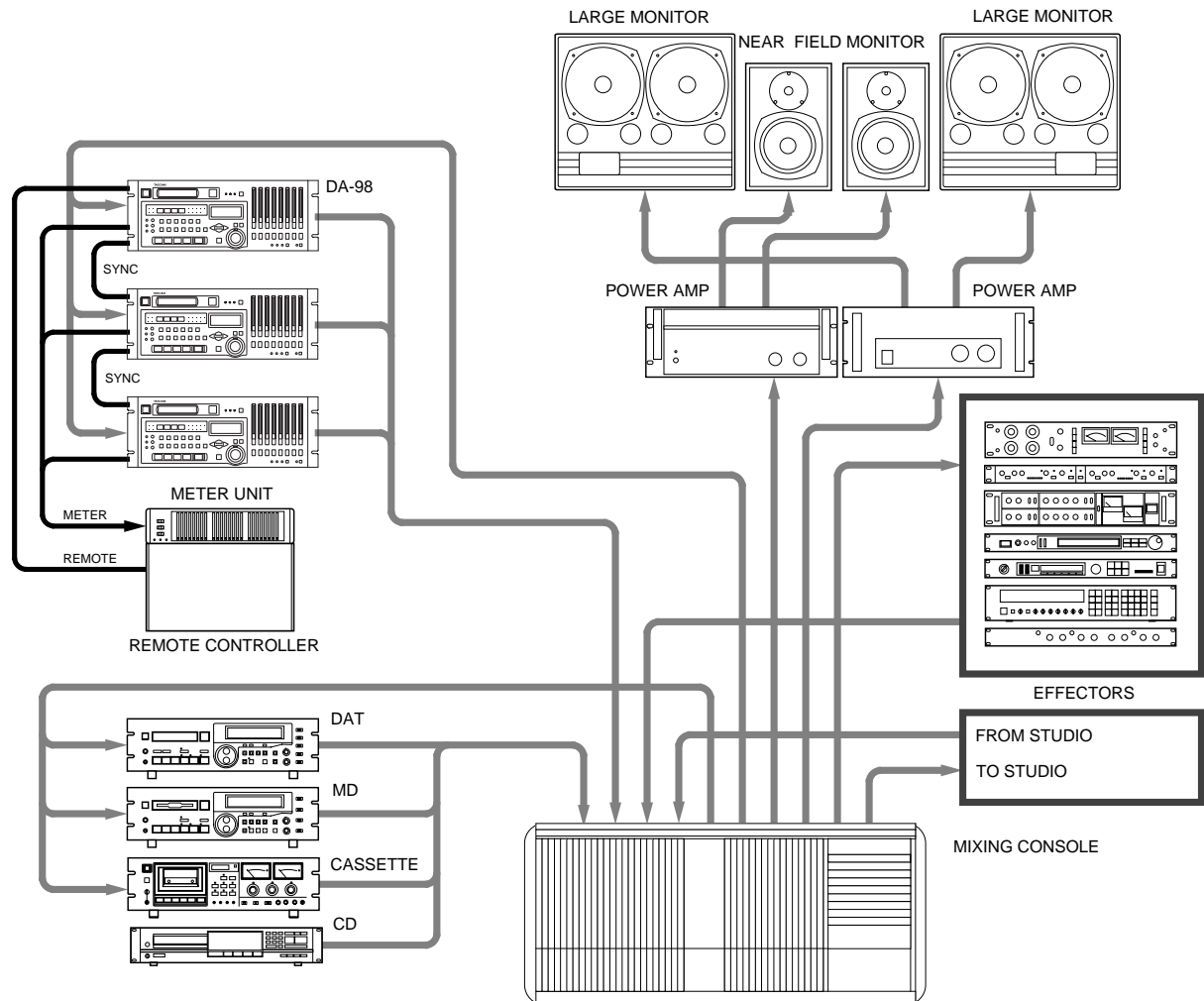

Many of the clients bring in worktapes or basic tracks recorded on their home DA-38s or from smaller project studios using a DTRS machine. The DA-98s in the studio can, naturally, use these tapes.

If a client brings in a different model of (timecode-based) machine and tape from a project studio, the DA-98's timecode facilities are used. Usually, though, timecode synchronization is not used, and the DA-98s are synchronized using DTRS synchronization.

The mixing console is a TASCAM M-5000 console. Since the integral patchbay of this console is already fitted with D-sub connectors, the cabling requirements are reduced – all track inputs and tape returns are carried on six cables, rather than 48.

Section 13 – Example setups

The tape returns and inputs are fed directly using cables such as the PW-10D and PW-4D into the patchbay's 25-pin D-sub connectors.

The studio is a small one, so there is no separate machine room, but the compact size of the DA-98 allows 24 fully-digital tracks to be kept in only 12U of rack space. A remote control and metering unit allows the whole studio to be controlled from one central location.

Mastering mixdown is carried out to DAT (TASCAM DA-30 MK II), with “take-home” copies made on MiniDisc (TASCAM MD-801) and analog cassette (TASCAM 302).

13.2 Post-production work.

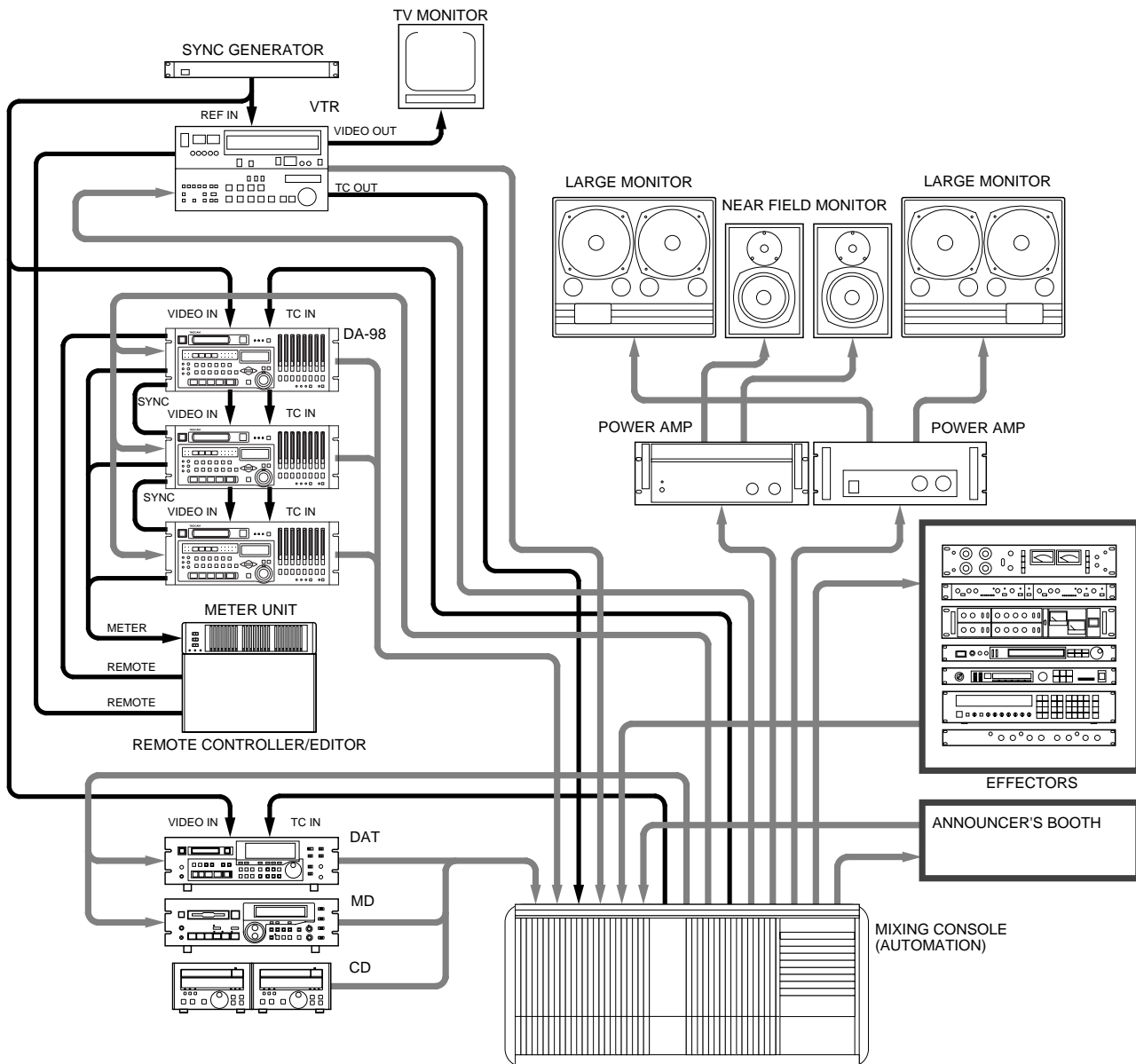

In the post-production world, the DA-98 excels, thanks to its flexible and sophisticated synchronization capabilities, which give it more control than ever before. The three DA-98 units are linked together in a timecode “daisy” chain, allowing them to function as one 24-track recorder, whether or not timecode is being received from the master source. The first (master) DA-98 has its timecode output set to TC Track, which means that

when timecode is received, it is re-transmitted, together with the offset set on the master unit(see 10.7.5, “Setting timecode offset on-the-fly”) . The slave DA-98s output reshaped timecode. When timecode is not being received, and the 3 DA-98s are to act as a single independent multitrack recorder, the **CHASE** key of the master DA-98 is the only key that needs to be pressed to change modes.

Each track can be individually delayed, with the delay units being selectable between milliseconds and samples, allowing even more precise synchronization.

Telecine facilities can also benefit from the extensive range of pull-up and pull-down sampling frequencies, allowing easy synchronization, even with the non-integer ratios imposed when converting standard 24fps film material to NTSC drop-frame color.

The DA-98 has the advantage of media compatibility with the DTRS tapes received from smaller suites and project studios, allowing a complete multitrack soundtrack to be built up from different sources.

In addition, the integration of the DA-98 into the post-production environment is completed by its extensive emulation facilities, allowing it to interface with a wide range of editor/controllers, reducing the need for additional investment. As new equipment is introduced, the “future-proof” nature of the DA-98 makes it ready for future developments

13.3 Project studio ('B' room)

The DA-98 provides an excellent recording solution for the smaller project studio.

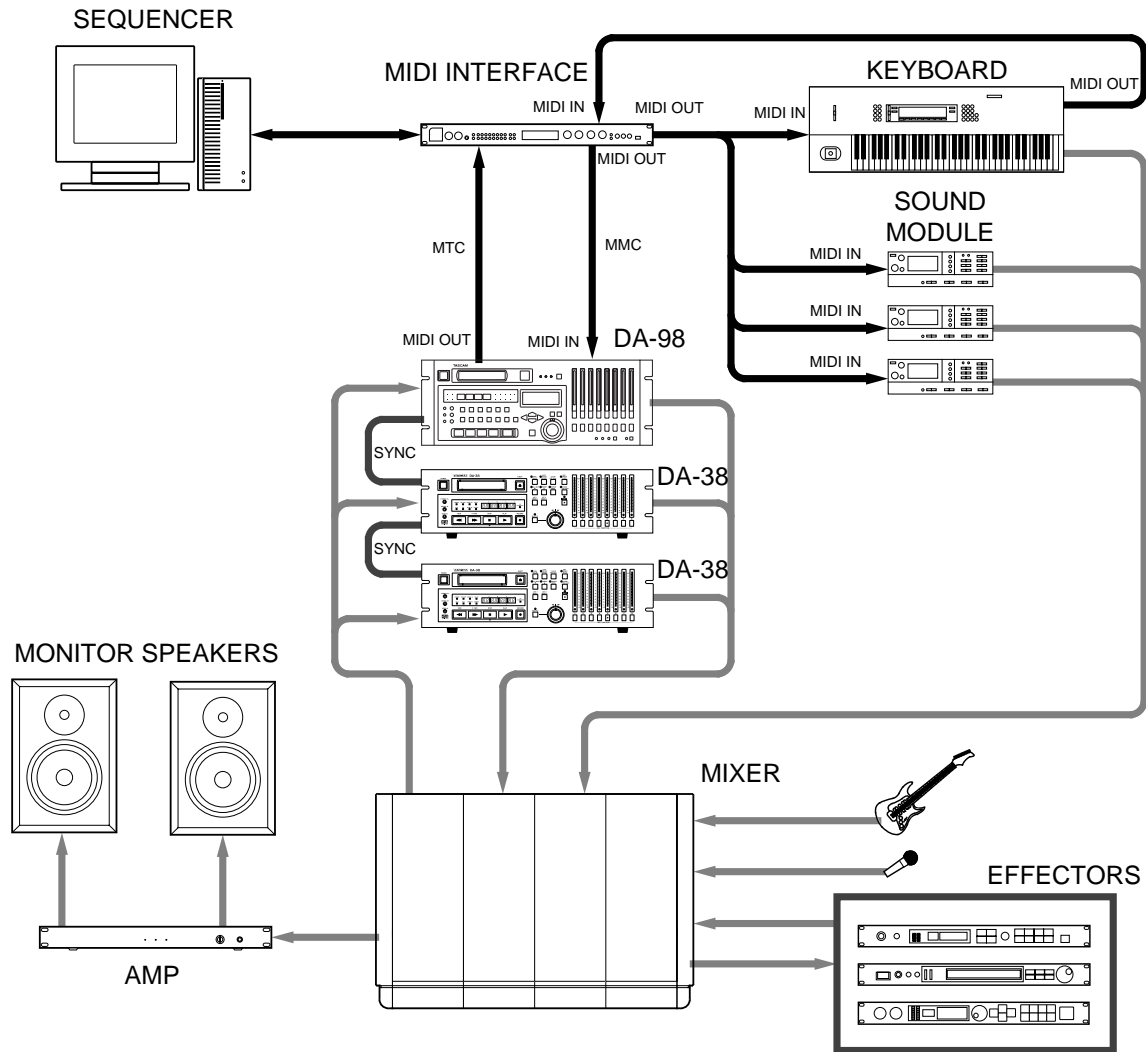

Since the machine itself is relatively small and portable, it can be transported to larger assembly studios which are not equipped with DTRS recorders. When the assembly studios use DTRS units, of course, the small size and compact nature of the Hi8 cassette medium makes it easy to transport working (and even master) tapes between locations.

Should the DA-98 be moved between locations, the different user setup memory banks allow instant switching of the DA-98 from the “master recorder” role in the project studio, to the “secondary recorder” role in the larger studio.

Digital dubbing involves no loss of quality, so project studio tapes may be duplicated as often as required, and the quality of the tapes produced “at home” is equal to those produced in the larger studio.

The DA-98 can be considered, in many ways, as a modular multitrack system, and hence the number of tracks available to the project studio can be incremented at relatively little cost and with no learning curve for the expansion. For project studios which are already using DTRS machines and require a little more functionality than is available from, say, the DA-38, the DA-98 represents an attractive upgrade path, adding addi-

tional tracks and integrated synchronization to the existing DA-38 system, while providing total media compatibility with existing recordings, as well as a familiar user interface.

The MIDI capabilities of the DA-98 are also of great value to the smaller studio, allowing the integration of the DA-98 with existing MIDI systems, synchronized using MIDI Time Code and, through MMC integration, effectively turning the digital audio tracks of the DA-98 into extra tracks of the sequencer.

Since recording can be carried out at the same time as formatting, it is possible to record whenever inspiration strikes, rather than being held back by the limitations of technology.

Section 13 – Example setups

14 – Maintenance and memory setups

14.1 Head and transport cleaning

The DA-98 incorporates an internal cleaning mechanism that not only cleans the rotary head, but also the tape as it enters the tape path. The provision of this cleaning mechanism significantly reduces the need for manual cleaning. If, despite the internal cleaning mechanism, the **PB CONDITION** indicator (page 2-1) lights, the heads are dirty and manual cleaning procedures should be followed.

Use a TEAC HC-8 cleaning tape (recommended) or a dry cleaning tape specially designed for Hi8 8mm video equipment.

WARNINGS

NEVER use a wet-type cleaning tape, as this will result in winding problems.

The use of the dry tape will reduce the head life of the DA-98 by about five hours. Use of manual cleaning is therefore discouraged.

We recommend the following schedule (based on our experience with the DTRS system) for cleaning and maintenance schedules. See 14.1.3, “Checking head time” below for details of how to check head usage time.

Every 350 to 400 hours Perform manual cleaning of heads and guides as described below. Check the tape path alignment after cleaning. This requires proper test and measurement equipment, and should be performed only by qualified service personnel.

Every 1000 hours (every third cleaning) A complete alignment check should be performed.

The above cleaning cycle timings are based on the assumption that the DA-98 is being operated in a clean environment. A dusty or smoky atmosphere

will shorten the time between cleaning operations.

NOTE

Most name brand tapes are of very high quality. However, it is sometimes possible to receive “bad” stock which exhibits excessive shedding characteristics. If you receive such tape stock, stop using it immediately, and follow the cleaning procedure as described below.

14.1.1 To clean the heads and transport

- 1) Use the cursor keys [25] so that the cursor is by menu group 9, and then press ENTER [27].

```
Select Menu Group
  0 1 2 3 4 5 6 7
  8 9 . . . E F
Clen/BER/Setup
```

If you do not see the screen above, press the **ESCAPE** key [27] until it appears.

- 2) Within menu group 9, move the cursor so that it is by **Cleaning**,

```
Cleaning Setup
BER DISP

Count:0000 off
```

- 3) Press ENTER:

```
Cleaning Mode

Count:0001 off
```

- 4) Press the **UP** or **DOWN** key to set the cleaning mode to **on**.

If a tape has already been loaded, it will automatically be ejected.

- 5) Insert the cleaning tape.

- 6) The cleaning tape will “play” for about 5 seconds and then be ejected automatically. The cleaning counter (number of times the heads have been cleaned) will be incremented by one.

Section 14 – Maintenance and memory setups

- Do not attempt to rewind or fast forward the cleaning tape, either in the DA-98 or in a video unit. Simply insert it into the DA-98 when you use it the next time.
- Excessive cleaning can cause excessive wear on the heads. Do not clean the heads too frequently, and never perform the head cleaning procedure more than 5 times running.
- In addition to cleaning the heads, we recommend that you have the DA-98 checked by an authorized TASCAM service technician every 500 hours or so of use.

14.1.2 Checking error rates

If you hear noise and distortion on playback, even after cleaning the heads, or if you are presented with a tape of dubious quality, you may want to check the error rate of the tape.

You can check the error rates at two tape positions, edge and center, for each of the two heads.

- 1) Use the cursor keys [25] so that the cursor is by menu group 9:

```
Select Menu Group
  0 1 2 3 4 5 6 7
  8 9 - - - - E F
Version/Drum time
```

- 2) Press ENTER:

```
Block Error Rate
AHead
BHead
      Tape Edge
```

- 3) Use the UP and DOWN keys to select between Edge and Center.

Block errors are shown by a solid block. It is inevitable that there will be a few errors, but if the display consists mainly of solid blocks while the tape is playing, something is wrong (and you will almost certainly be able to hear it!).

Use this display to show where the tape is in error, and which head is causing errors. In this way, you can pinpoint the cause of trouble.

If playing another tape seems to remove the errors, the problem is with the tape, otherwise you may want to clean the heads (see 14.1, “Head and transport cleaning”). Remember not to clean the heads more than 5 times in a row.

NOTE

If, after trying different tapes and cleaning the heads, you still see many errors, you should contact a TASCAM service technician to check your DA-98.

14.1.3 Checking head time

This function allows you to check the number of hours that the head has been used in play or record mode.

- 1) Use the cursor keys [25] so that the cursor is by menu group F, and then press ENTER [27].

```
Select Menu Group
  0 1 2 3 4 5 6 7
  8 9 - - - - E F
Version/Drum time
```

- 2) Within menu group F, move the cursor so that it is by the Dr total field. The number of whole hours that the head has been in use will be shown on the bottom line of the display.

```
Sys ver   Front ver
Servo ver  Sync ver
Dr total  Dr search
          0014
```

14.1.4 Checking head search time

This allows you to check the number of hours that the head has spent in fast forward and rewind modes:

- 1) Use the cursor keys [25] so that the cursor is by menu group F:

```
Select Menu Group
  0 1 2 3 4 5 6 7
  8 9 - - - - E F
Version/Drum time
```

- 2) Press ENTER.

- 3) Within menu group F, move the cursor so that it is by the `Dr search` field. The number of whole hours that the head has been in use for fast forward and fast rewind will be shown on the bottom line of the display.

```

Sys ver   Front ver
Servo ver Sync ver
Dr total  Dr search
          0002
    
```

14.2 Memory backup

The DA-98 includes non-volatile memory (NVRAM) which preserves almost all user settings after the power is turned off.

14.3 User setups

You can save commonly-used setups in one of three user setup memory banks: 1, 2 or 3. This enables you to pre-configure the DA-98 for different jobs (video or film post-production, or different recording setups, for example). There is also a preset memory bank which contains the factory settings (see below).

When the DA-98 is shipped, the contents of all setup memories are the same; they contain the factory settings.

14.3.1 Saving user setups

- 1) Go to menu group 9, move the cursor to `Setup` and press `ENTER`:

```

Setup
          Load  1 2 3 F
    
```

- 2) To store the current setup, use the `UP` and `DOWN` keys so that the bottom line reads `Save`:

```

Setup
          Save  1 2 3
    
```

- 3) Move the cursor to 1, 2 or 3, and press the `UP` or `DOWN` key:

```

Setup
          Ready ?
          Save  1 2 3
    
```

- 4) The word `Ready?` will flash on the screen. To save the current setup to the selected setup memory, press the `UP` or `DOWN` key.

The word `Done` will appear on the screen for about 2 seconds and the user settings will be stored to the selected setup memory bank.

14.3.2 Loading user setups

- 1) Go to menu group 9, move the cursor to `Setup` and press `ENTER`:

```

Setup
          Load  1 2 3 F
    
```

- 2) To load the setup memory into the current memory, use the `UP` and `DOWN` keys so that the bottom line reads `Load`:

```

Setup
          Load  1 2 3 F
    
```

- 3) Move the cursor to 1, 2 or 3, and press the `UP` or `DOWN` key:

```

Setup
          Ready ?
          Load  1 2 3 F
    
```

The word `Done` will appear on the screen for about 2 seconds..

The contents of the currently-selected setup will be loaded into memory.

Section 14 – Maintenance and memory setups

14.3.3 Resetting the memory

You may sometimes want to reset all of the memory to factory settings. The values of all the factory settings are listed in 12, “Menu and parameter reference”.

- 1) Go to menu group 9, move the cursor to Setup and press ENTER:

```
Setup
      Load 1 2 3 F
```

- 2) Press UP or DOWN to select Load from between Load and Save.
- 3) Use the RIGHT key to move the cursor to F (factory). Press the UP key, and you will see the word Ready? flashing on the screen.
- 4) Press the UP key again to change the Ready ? to Done. This confirms that the memory has been reset to factory settings.

14.4 Checking version numbers

In case of problems, you may need to quote the version number of the DA-98's internal software components to a TASCAM representative.

- 1) Use the cursor keys [25] so that the cursor is by menu group F, and then press ENTER [27].

```
Select Menu Group
      0 1 2 3 4 5 6 7
      8 9 - - - - E F
Version/Drum time
```

- 2) Within menu group F, move the cursor so that it is by the Sys ver (system version), Front ver (front panel software version), Servo ver (servo control software version) or Sync ver (version of the

synchronization software) field. The version number of the appropriate software will be shown on the bottom line of the display.

```
Sys ver   Front ver
Servo ver  Sync ver
Dr total  Dr search
          Ver 1.00
```

14.4.1 Software upgrades

TASCAM pursues a policy of continuous improvement to products, and there may be future enhancements to the DA-98 software. Your TASCAM dealer will be able to advise you of developments in this area.

15 – Options, specifications and reference

15.1 Options for the DA-98

You can purchase a number of options through your TASCAM dealer.

15.1.1 RM-98 Rack Mount Adaptor

The RM-98 Rack Mount Adaptor consists of a pair of rack handles which can be fitted to the DA-98 to help with removing it from the rack for transportation, etc.

To fit these handles, you must first remove the rack mounting ears fitted to the DA-98 as shipped, and attach the handles as shown in the illustration below.

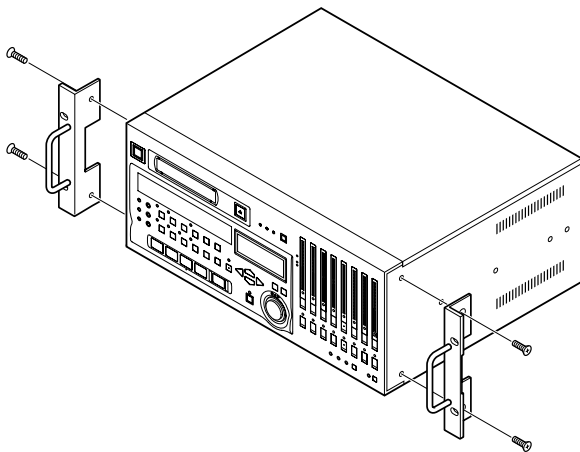

The DA-98 is also fitted with screw holes in the case which allow you to fit Accuride®¹ 200 series guide rails (18" or 20") which also help with removing and replacing the DA-98 from and to rack installations.

Accuride strips are fitted as shown below:

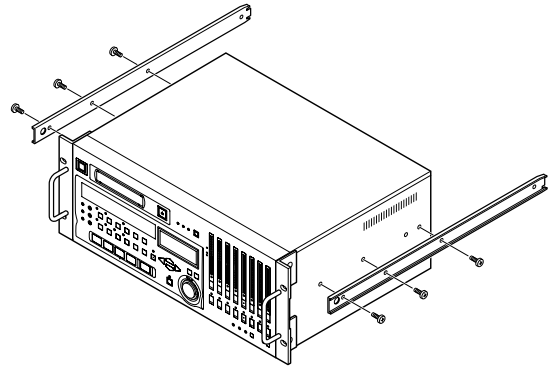

Make sure that all screws and bolts are securely tightened before replacing the DA-98 in the rack.

15.1.2 Remote control (RC-848)

The RC-848 Multi-unit Remote Controller can be used with the DA-98 as well as the DA-88 and DA-38 DTRS recorders. However, note that not all functions of the DA-98 can be used with the RC-848.

The RC-848 can be rack-mounted using the RM-8824, or placed on a roll-around stand (CS-848).

If a longer cable is required, the 10 meter (30 ft.) PW-848L can be used.

The RC-848 can also be connected to units with an ACCESSORY-2 connector. For these purposes, the PW88-AC2 cable is required.

- If an RC-848 controller is used, it should be connected to the DA-98's **REMOTE IN/SYNC IN** connector [43].
- Up to 6 DTRS units can be controlled using one RC-848 controller.
- The first DA-98 or DA-38 unit in the chain should be given Machine ID 1 (ID 0 for DA-88 units), even if an RC-848 is used.
- The last DTRS unit in the chain (even if it is the only one) must be terminated at the **SYNC OUT** connector [44] using a TASCAM terminator.

15.1.3 Meter unit (MU-8824)

The optional MU-8824 external meter bridge unit can be connected using a PW-88M cable from the **METER UNIT** connector [46].

¹ Accuride is a registered trademark of Accuride International Inc.

Section 15 – Options, specifications and reference

The meter can be rack mounted using the RM-8824 rack mount angle accessory or mounted on the RC-848 using the MK-8824 mounting kit.

No settings are necessary on the DA-98 to use this meter unit.

15.1.4 Digital audio convertors

TASCAM supply two types of convertor which allow conversion between TDIF-1 and other digital audio formats.

The IF-88AE converts between eight audio channels of TDIF-1 and AES/EBU (SPDIF), and the IF-88SD converts between eight audio channels of SDIF-2 and TDIF-1.

The cables used to connect the IF88-SD to the SDIF-2 device are:

Cable	Purpose
PW-SD1	IF-88 → SDIF-2
PW-SD2	SDIF-2 → IF-88

15.1.5 Cables

As mentioned, TASCAM cannot accept any responsibility for damage caused by the use of the wrong cables.

Always consult your TASCAM dealer to see if there is a ready-made cable to meet your needs. The TASCAM cables to be used with the DA-98 (at the time of writing this manual) are given in the table below:

Cable	Purpose
PW-88D	1 m (3 ft.) DA-98 ↔ DTRS digital dubbing cable
PW-88DL	5 m (15 ft.) DA-98 ↔ DTRS digital dubbing cable
PW-88S	1 m (3 ft.) DA-98 ↔ DTRS sync cable
PW-2D	2m (6 ft.) analog balanced audio I/O cable (e.g. DA-98 ↔ M1600)
PW-4D	4m (12 ft.) analog balanced audio I/O cable (e.g. DA-98 ↔ M1600)
PW-10D	10m (30 ft.) analog balanced audio I/O cable (e.g. DA-98 ↔ M1600)

Cable	Purpose
PW-1ES	1m (3 ft.) standard 9-pin RS-422 cable
PW-5ES	5m (15 ft) standard 9-pin RS-422 cable
PW-88M	External meter connecting cable

15.1.6 CONTROL I/O connector pinout

Pin No.	Signal	Pin No.	Signal
1	PLAY	20	SUB GND
2	FFWD	21	SERIAL OUT
3	REW	22	–
4	AUX 1	23	SERIAL IN
5	STOP	24	–
6	REC	25	2 FS
7	AUX 2	26	FLAG 1
8	CHASE	27	FLAG 2
9	–	28	C2
10	SUB GND	29	2F SYNC
11	PLAY TALLY	30	F SYNC
12	FFWD TALLY	31	–
13	REW TALLY	32	SRCK
14	STOP TALLY	33	–
15	REC TALLY	34	LOAD
16	LOCK TALLY	35	–
17	AUX 1 TALLY	36	SUB GND
18	AUX 2 TALLY	37	SUB 5 V (max 50mA)
19	ACTIVE SENSE		

15.2 Specifications

Maximum recording time	108 min (using P6 120 tape)
Other features	Up to 16 DTRS units can be synchronized, giving up to 128 recording tracks

15.2.1 Physical specifications

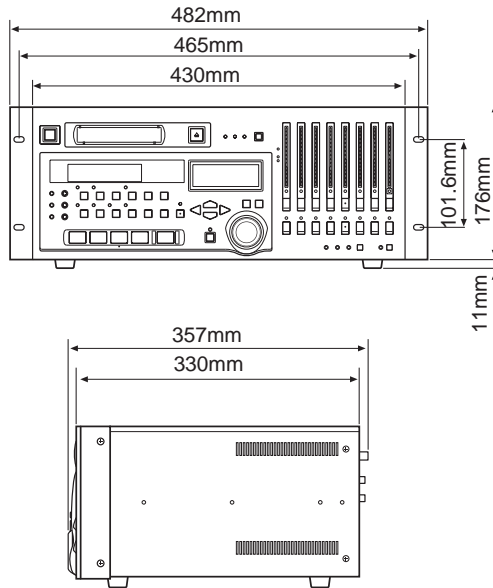

Size (exc feet) w x h x d	482 x 176 x 357 (mm)
	19 x 6.9 x 14.1 (in)
Weight	11 kg (24 lb)

15.2.2 Power specifications

Power requirements	USA/Canada 120 VAC, 60 Hz
	U.K./Europe 230 VAC, 50 Hz
	Australia 240 VAC, 50 Hz
Power consumption	62W

15.2.3 Digital recording characteristics

Number of recording tracks	8
Sub-code	ABS track, SMPTE/EBU timecode facility
Sampling frequency	44.1 kHz, 48 kHz
Recording resolution	16 bits linear
Error correction	Double-encoded Reed-Solomon code

15.2.4 Tape recorder section

Format	DTRS format
Recording method	Rotary-head, helical-scan method
Tracking method	ATF
Erasure method	Overwrite
Head construction	2 x record, 2 x playback
Tape type	Hi8 MP tape / Hi8 ME

Section 15 – Options, specifications and reference

15.2.5 Tape transport

Vari speed	±6% (0.1% steps)
Fast forward/rewind time	80 seconds (using P6 120 tape)
Time to play from stop	Less than 2 seconds
Search speed	Maximum of 100 x play speed
Shuttle speed	Forward and reverse at 8.0, 4.0, 2.0, 1.0, 0.5 and 0.25 play speed (1.0 speed available only in forward shuttle mode)
Positioning accuracy	To 1 sample
Positioning lock time	Within 8 seconds (when locating 2 DA-98s synced together)

15.2.6 Inputs and outputs

Analog inputs	D-sub 25-pin balanced +4 dBu nominal (fullscale –16, –18 or –20 dB, selectable) Impedance: 20k Ω
Analog outputs	D-sub 25-pin balanced +4 dBu nominal (fullscale = –16, –18 or –20 dB, selectable) Maximum output levels +20 dBu (ref. level –16 dB) +22 dBu (ref. level –18 dB) +24 dBu (ref. level –20 dB) Impedance: 10k Ω
Digital I/O	D-sub 25-pin TDIF-1 format
Remote in/sync in	D-sub 15-pin Conforms to REMOTE IN/ SYNC IN protocol
Sync out	D-sub 15-pin Conforms to REMOTE IN/ SYNC IN protocol
Word clock in/thru	BNC connector, 75 Ω at TTL level ON/OFF (THRU auto- terminated)
Word clock out	BNC connector, 75 Ω at TTL level
Level meter output	D-sub 15-pin
Timecode input	XLR-3 balanced Input impedance: > 10 k Ω Input level: 0.5 Vp-p to 10.0V p-p
Timecode output	XLR-3 balanced Output impedance (< 100 Ω) Output level: 2.0 V p-p

Video INPUT/THRU	NTSC or PAL Negative Sync Composite Video, Sync Composite Video or Frame Pulse (auto detect) 1 V p-p, ±0.2 V (Negative Sync Composite Video or Sync Composite Video) TTL Level (Frame Pulse) THRU automatically termi- nated (75 Ω)
MIDI RS-422	IN, OUT, THRU D-sub 9-pin Conforms to RS-422 specifi- cations

15.2.7 Audio specifications

Maximum output level	20 dBu, 22 dBu, 24 dBu, ±1dB 3 levels are selectable Impedance load of 10 k Ω
Frequency response	20 Hz to 20 kHz ±0.5 dB
Signal-to-noise ratio (Fs=48kHz, Ref level= –16 dB)	Source monitor > 100 dB (22 k LPF and A-weight) Recording / playback > 97 dB (22 k LPF and A-weight)
Dynamic range (Fs=48kHz, Ref level= –16 dB)	Source monitor > 100 dB (22 k LPF and A-weight) Recording / playback > 97 dB (22 k LPF and A-weight)
Total harmonic distortion and noise	Source monitor < 0.006% Recording / playback < 0.006% (REC/PLAY 1 kHz SIN full-scale –0.5dB, 22 k LPF and A-weight)
Crosstalk	> 90 dB at 1kHz
Emphasis	50/15 μ s (playback)
Cross-fade time	10ms to 200ms (10ms incre- ments)
Track delay	–200 to +7,200 samples (–4 to +150 ms) in single-unit increments. Can be set in samples or ms.
Offset	±2 hours (to frame accuracy)

15.2.8 9-pin (RS-422), MIDI, synchronizer specifications

MMC functions	Track delay, track copy con- trolled by System Exclusive messages
Supported timecode formats	SMPTE 30, 29.97 drop, 29.97 non-drop, EBU 25 and Film 24 fps

Timecode offset	Up to 24 hours (jamsync capability) ABS to SMPTE conversion facility (with offset)
Video sync	Video frame resolvable even when VIDEO not selected as clock source

Section 15 – Options, specifications and reference

15.3 MMC Bit Map Array

Commands unavailable on the DA-98 are struck through, as for example (~~RECORD PAUSE~~).

Byte	Bit 7	Bit 6 (40H)	Bit 5 (20H)	Bit 4 (10H)	Bit 3 (08H)	Bit 2 (04H)	Bit 1 (02H)	Bit 0 (01H)
c0	- 0	(06) RECORD STROBE	(05) REWIND	(04) FAST FORWARD	(03) DEFERRED PLAY	(02) PLAY	(01) STOP	(00) reserved
c1	- 0	(0D) MMC RESET	(0C) COMMAND ERROR RESET	(0B) CHASE	(0A) EJECT	(09) PAUSE	(08) RECORD PAUSE	(07) RECORD EXIT
c2	- 0	(14)	(13)	(12)	(11)	(10)	(0F)	(0E)
c3	- 0	(1B)	(1A)	(19)	(18)	(17)	(16)	(15)
c4	- 0	- 0	- 0	- 0	(1F)	(1E)	(1D)	(1C)
c5	- 0	(26)	(25)	(24)	(23)	(22)	(21)	(20)
c6	- 0	(2D)	(2C)	(2B)	(2A)	(29)	(28)	(27)
c7	- 0	(34)	(33)	(32)	(31)	(30)	(2F)	(2E)
c8	- 0	(3B)	(3A)	(39)	(38)	(37)	(36)	(35)
c9	- 0	- 0	- 0	- 0	(3F)	(3E)	(3D)	(3C)
c10	- 0	(46) SEARCH	(45) VARIABLE PLAY	(44) LOCATE	(43) UPDATE	(42) READ	(41) MASKED WRITE	(40) WRITE
c11	- 0	(4D) ADD	(4C) MOVE	(4B) MTC COMMAND	(4A) GENERATOR COMMAND	(49) ASSIGN SYS-MAS	(48) STEP	(47) SHUTTLE
c12	- 0	(54) DEFERRED VARI. PLAY	(53) COMMAND SEGMENT	(52) GROUP	(51) EVENT	(50) PROCEDURE	(4F) DROP FR. ADJUST	(4E) SUBTRACT
c13	- 0	(5B)	(5A)	(59)	(58)	(57)	(56)	(55) REC STROBE VARIABLE
c14	- 0	- 0	- 0	- 0	(5F)	(5E)	(5D)	(5C)
c15	- 0	(66)	(65)	(64)	(63)	(62)	(61)	(60)
c16	- 0	(6D)	(6C)	(6B)	(6A)	(69)	(68)	(67)
c17	- 0	(74)	(73)	(72)	(71)	(70)	(6F)	(6E)
c18	- 0	(7B)	(7A)	(79)	(78)	(77)	(76)	(75)
c19	- 0	- 0	- 0	- 0	(7F) RESUME	(7E)	(7D)	(7C) WAIT

Section 15 – Options, specifications and reference

Byte	Bit 7	Bit 6 (04H)	Bit 5 (20H)	Bit 4 (10H)	Bit 3 (08H)	Bit 2 (04H)	Bit 1 (02H)	Bit 0 (01H)
r0	- 0	(06) GENERATOR TIME CODE	(05) LOCK DEVIATION	(04) ACTUAL OFFSET	(03) REQUESTED OFFSET	(02) SELECTED MASTER CODE	(01) SELECTED TIME CODE	(00) reserved
r1	- 0	(0D) GP5	(0C) GP4	(0B) GP3	(0A) GP2	(09) GP1	(08) GP0/LOCATE POINT	(07) MTC INPUT
r2	- 0	(14)	(13)	(12)	(11)	(10)	(0F) GP7	(0E) GP6
r3	- 0	(1B)	(1A)	(19)	(18)	(17)	(16)	(15)
r4	- 0	- 0	- 0	- 0	(1F)	(1E)	(1D)	(1C)
r5	- 0	(26) Short GENERATOR TIME CODE	(25) Short LOCK DEVIATION	(24) Short ACTUAL OFFSET	(23) Short REQUIRED OFFSET	(22) Short SELECTED MASTER CODE	(21) Short SELECTED TIME CODE	(20) reserved
r6	- 0	(2D) Short GP5	(2C) Short GP4	(2B) Short GP3	(2A) Short GP2	(29) Short GP1	(28) Short GP0 LOCATE POINT	(27) Short MTC INPUT
r7	- 0	(34)	(33)	(32)	(31)	(30)	(2F) Short GP7	(2E) Short GP6
r8	- 0	(3B)	(3A)	(39)	(38)	(37)	(36)	(35)
r9	- 0	- 0	- 0	- 0	(3F)	(3E)	(3D)	(3C)
r10	- 0	(46) SELECTED TIME CODE SOURCE	(45) TIME STANDARD	(44) COMMAND ERROR LEVEL	(43) COMMAND ERROR	(42) RESPONSE ERROR	(41) UPDATE RATE	(40) SIGNATURE
r11	- 0	(4D) RECORD STATUS	(4C) RECORD MODE	(4B) FAST MODE	(4A) STOP MODE	(49) VELOCITY TALLY	(48) MOTION CONTROL TALLY	(49) SELECTED TIME CODE USER BITS
r12	- 0	(54) STEP LENGTH	(53) TRACK INPUT MONITOR	(52) TRACK SYNC MONITOR	(51) RECORD MONITOR	(50) GLOBAL MONITOR	(4F) TRACK RECORD READY	(4E) TRACK RECORD STATUS
r13	- 0	(5B) GENERATOR COMMAND TALLY	(5A) CHASE MODE	(59) RESOLVED PLAY MODE	(58) CONTROL DISABLE	(57) LIFTER DEFEAT	(56) FIXED SPEED	(55) PLAY SPEED REFERENCE
r14	- 0	- 0	- 0	- 0	(5F) MTC SETUP	(5E) MTC COMMAND TALLY	(5D) GENERATOR USER BITS	(5C) GENERATOR SETUP
r15	- 0	(66)	(65) FAILURE	(64) RESPONSE SEGMENT	(63) VITC INSERT ENABLE	(62) TRACK MUTE	(61) EVENT RESPONSE	(60) PROCEDURE RESPONSE
r16	- 0	(6D)	(6C)	(6B)	(6A)	(69)	(68)	(67)
r17	- 0	(74)	(73)	(72)	(71)	(70)	(6F)	(6E)
r18	- 0	(7B)	(7A)	(79)	(78)	(77)	(76)	(75)
r19	- 0	- 0	- 0	- 0	(7F) RESUME	(7E)	(7D)	(7C) WAIT

A

ABS frame rate *10-1*
 ABS time *10-1*
 auto timecode settings *10-3*
 ABS-13 setting *10-3*
 Absolute difference *10-12*
 Absolute time
 see "ABS time"
 AES/EBU conversion *15-2*
 ALL INPUT *7-1*
 Ambient temperature *1-3*
 Analog audio connections *4-1*
 Analog outputs
 synchronizing with timecode *10-6*
 Analog timecode connections *4-1*
 Analog track mapping *11-3*
 Arming tracks *7-3*
 Assembling timecode *10-8*
 Assigning menus to "soft keys" *5-4*
 Audio connections *4-1*
 AUTO MON function *7-1*
 Auto play *8-3*
 Autolocation
 see "Location points"
 Automatic park position setting *10-12*
 Automatic punch point setting *6-4*

B

Backup of parameters *14-3*
 BER
 see "Block Error Rate"
 Blanking the screen display *5-2*
 Block Error Rate *14-2*
 Bus ID *11-4*
 Bus protocol *11-4*
 Bypassing timecode errors *10-13*

C

Cables *15-2*
 Cancelling machine offset *9-3*
 Cassette types *1-4*
 Channel-to-track routing *8-8*
 Chase mode *9-2*
 Chase to timecode *10-10*
 Checking error rates *14-2*
 Checking head search time *14-2*
 Checking head time *14-2*
 Checking location points *8-1*
 Condensation *1-3*
 Confidence mode *7-2*
 Control connections *4-2*

Control protocol *11-1*
 Crossfade times *8-4*
 Cue-up tally *11-2*
 Cursor keys *5-1*

D

DA-38 *9-1*
 DA-88 *9-1*
 Default settings *14-4*
 Delaying tracks *8-4*
 Dew warning *1-3*
 Digital dubbing *9-4*
 Digital input selection *8-8*
 Digital outputs
 synchronizing with timecode *10-6*
 Digital recording characteristics *15-3*
 Digital track mapping *11-3*
 Dither *7-2, 8-8, 8-9*
 DTRS *1-4*
 DTRS synchronization *9-1*
 Dubbing *9-4*

E

Editing function key memories *8-2*
 Editing location points *8-1*
 Editing time values *5-2*
 Editing values *5-1*
 Electrical considerations *1-3*
 Emulation *4-2, 11-1*
 Environmental conditions *1-3*
 Error rate checking *14-2*
 ESCAPE *5-1*
 ESCAPE key *5-1*
 Exiting punch-in mode *6-7*
 External Control
 fast wind speed *11-2*
 External control
 bus protocol *11-4*
 cue-up tally *11-2*
 emulation *11-1*
 record delay *11-1*
 RS-422 *11-1*
 selecting source *11-1*
 timecode track mapping *11-3*
 track mapping *11-3*
 External timecode sources *10-8*

F

Factory settings
 restoring *14-4*
 Fast Wind Speed *11-2*

Index

Formatting *6-1*
Frame rate *10-4*
 ABS timing *10-1*
Fs shift *10-4*
Function keys
 location memories *8-2*
 menu setting *5-4*
 modes *5-2*
 numerical keypad *5-3*
 "Ten key" *5-3*

G

Generating timecode *10-6*

H

Head cleaning *14-1*
Head search time, checking *14-2*
Head time, checking *14-2*

I

ID
 see "Machine ID"
INPUT MONITOR *7-1*
Input selection *8-8*
Inputs and output specifications *15-4*
Interrupting a rehearsal or punch recording *6-6*

L

Location points
 auto play *8-3*
 auto-repeat *8-3*
 editing *8-1, 8-2*
 function key memories *8-2*
 locating *8-2*
 setting pre-roll time *8-1*
LTC *10-5*

M

Machine ID *9-1, 10-10*
 setting *9-2*
Machine offset *9-2*
Manually entering location points *8-1*
Mapping the timecode track *11-4*
Mapping tracks for external control *11-3*
Master/slave settings *9-1, 9-2*
ME tapes *1-4*
Memory backup *14-3*
Menu groups *5-1*

Menu operations *5-1*
Meter ballistics *8-7*
Meter unit *4-3, 15-1*
Meters *8-7*
MIDI functions *4-3*
MIDI ID *11-4*
MIDI Implementation Chart *15-8*
MIDI Machine Control *4-2, 11-4, 15-6*
MIDI Time Code *4-2, 10-6*
MMC
 see "MIDI Machine Control"
Monitoring *7-1*
Monitoring controls *7-1*
MP tapes *1-4*
MU-8824 *4-3, 15-1*

N

9-pin external control
 see "RS-422 external control"
Number keys *5-3*

O

Offset
 DTRS synchronization *9-2*
Offset (timecode) *10-11*
Off-tape monitoring *7-1, 7-2*
Oscillator *8-7*
Overdubbing *6-3*

P

P2 protocol *4-2*
Parallel control *4-3*
Park position *10-12*
Peak hold time *8-7*
Physical specifications *15-3*
Pitch control *8-5*
Post-roll time *6-5*
 see also "Pre-roll time" *6-5*
Power-on message *8-10*
Pre-roll time
 editing *6-5*
 location *8-1*
 punching *6-5*
Propagation delay *8-4*
Pull up and pull down *10-4*
Punch-in mode
 exiting *6-7*
Punch-ins
 crossfade times *8-4*
 interrupting *6-6*
 introduction *6-3*

- recording 6-6
- rehearsing 6-6
- replaying 6-7
- setting punch points 6-4, 6-5
- PW-88S (cable) 9-1

R

- Rack mount adaptor (RM-98) 15-1
- Rack mounting 1-3
- REC MUTE function 8-9
- Rechasing timecode 10-13
- Record delay 11-1
- Recording punch-ins 6-6
- Recording time 1-5
- Recording timecode from external sources 10-9
- Rectangular dither 8-10
- Reference levels 8-6
- Rehearsing punch-ins 6-6
- Relative difference 10-12
- Relative humidity 1-3
- Repeat function 8-3
- Repeat playback 8-3
- Replaying punched material 6-7
- Replaying tracks 6-3
- Resetting a menu value 5-2
- Resetting the memory 14-3
- Restoring factory settings 14-4
- Routing 8-9
- RS-422 external control 11-1

S

- Saving user settings 14-3
- SDIF-2 conversion 15-2
- Selecting the timecode source 10-6
- Selecting timecode or absolute timing 10-1
- Setting location points 8-1
- Setting machine ID 9-2
- Setting machine offset 9-2
- Setting machine offset “on the fly” 9-3
- Setting punch points “on the fly” 6-4
- Setting punch points using the menus 6-5
- Setting the location pre-roll time 8-1
- Shuttle 8-5
- Shuttle monitoring 7-2, 8-6
- Shuttle muting 8-6
- Sine oscillator 8-7
- Soft keys 5-4
 - see “Function keys” 5-4
- Software upgrades 14-4
- Software version numbers 14-4
- Sony P2 protocol 4-2
- Source monitoring 7-1

- Synchronization
 - PW-88S cable 9-1
 - with other DA units 9-1
- Synchronization connections 4-1, 9-1

T

- Tape errors 14-2
- Tape head cleaning 14-1
- Tape length 1-5
- Tape transport specifications 15-4
- Tape types 1-4
- TC time 10-1
- Telecine 10-4
- Test tone 8-7
- Timecode
 - ABS times 10-1
 - ABS to timecode with offset 10-2
 - absolute and relative difference 10-12
 - assemble 10-8
 - automatic settings 10-3
 - bypassing errors 10-13
 - chasing 10-10
 - checking external timecode 10-9
 - external sources 10-8
 - fast LTC 10-5
 - frame rate 10-4
 - from analog source 10-9
 - from digital source 10-9
 - from tape 10-6
 - generator 10-6
 - input 10-4
 - machine ID 10-10
 - offset 10-11
 - output 10-5
 - output during fast operations 10-5
 - output timing 10-5
 - park position 10-12
 - rechasing 10-13
 - recording from external sources 10-9
 - regenerating 10-5
 - selecting the source 10-6
 - synthesizing from ABS 10-8
 - synthesizing from ABS timings 10-2
 - TC time 10-1
 - video resolution 10-10
- Timecode Record Enable
 - see “Timecode track mapping”
- Timecode time
 - see “TC time”
- Timecode track mapping 11-3
- Top menu 5-1
- Track Copy 6-2, 8-8
- Track delay 8-4
- Track mapping 11-3

Index

U

User setups *14-3*

V

Vari-speed *8-5*

Video clock *10-10*

Video clock connections *4-2*

Video frame clock *11-1*

Video resolution *10-10*

Viewing incoming timecode *10-4*

W

Word clock connections *4-2*

Word length *8-8*

Write-protecting cassettes *6-2*

TASCAM

TEAC Professional Division

DA-98

TEAC CORPORATION

Phone: (0422) 52-5082

3-7-3, Nakacho, Musashino-shi, Tokyo 180-8550, Japan

TEAC AMERICA, INC.

Phone: (323) 726-0303

7733 Telegraph Road, Montebello, California 90640

TEAC CANADA LTD.

Phone: 905-890-8008 Facsimile: 905-890-9888

5939 Wallace Street, Mississauga, Ontario L4Z 1Z8, Canada

TEAC MEXICO, S.A. De C.V

Phone: 5-658-1943

Privada De Corina, No.18, Colonia Del Carmen Coyoacan, Mexico DF 04100

TEAC UK LIMITED

Phone: 01923-819699

5 Marlin House, Marlins Meadow, The Croxley Centre, Watford, Herts. WD1 8YA, U.K.

TEAC DEUTSCHLAND GmbH

Phone: 0611-71580

Bahnstrasse 12, 65205 Wiesbaden-Erbenheim, Germany

TEAC FRANCE S. A.

Phone: 01.42.37.01.02

17 Rue Alexis-de-Tocqueville, CE 005 92182 Antony Cedex, France

TEAC BELGIUM NV/SA

Phone: 0162-510860

Oeverkruid 15, NL-4941 VV Raamsdonksveer, Netherlands

TEAC NEDERLAND BV

Phone: 0162-510210

Oeverkruid 15, NL-4941 VV Raamsdonksveer, Netherlands

TEAC AUSTRALIA PTY.,LTD. A.C.N. 005 408 462

Phone: (03) 9644-2442

106 Bay Street, Port Melbourne, Victoria 3207, Australia

TEAC ITALIANA S.p.A.

Phone: 02-66010500

Via C. Cantù 11, 20092 Cinisello Balsamo, Milano, Italy