

E4210

[KYOCERA DuraMax]

User Guide



©2011 Sprint. SPRINT and the logo are trademarks of Sprint. KYOCERA is a registered trademark of Kyocera Corporation. Other marks are the property of their respective owners.

Table of Contents

Get Started.....	1
Your Phone at a Glance	1
Set Up Your Phone	1
Activate Your Phone.....	2
Set Up Voicemail.....	3
Sprint Account Information and Help.....	4
Sprint Account Passwords	4
Manage Your Account	4
Sprint Support Services	5
Phone Basics	6
Your Phone’s Layout.....	7
Key Functions	7
Turn Your Phone On and Off	9
Battery and Charger	9
View the Display Screen	10
Navigate Through the Menus	14
Display Your Phone Number.....	14
Enter Text.....	14
Select a Text Input Mode.....	15
T9 Text Input.....	16
ABC Mode	16
Set Text Entry Options.....	16
Simple Data Exchange.....	17
Phone Calls & Settings	20
Make Phone Calls	20
Call Using the Phone Keypad.....	20
Call With the Phone Closed.....	21
Call From History	21
Call From Contacts	21
Call Using the Plus (+) Code	22

Call Using a Speed Dial Number	22
Call Using Abbreviated Dialing Features	22
Call a Phone Number With Pauses	23
Call a Phone Number in a Message	23
Call Emergency Numbers	24
Receive Phone Calls	25
Answer an Incoming Call With the Phone Open.....	25
Answer an Incoming Call With the Phone Closed	25
Answer an Incoming Call in Speakerphone Mode	25
Answer a Roam Call With Roaming Guards Enabled	26
Mute the Ringer and Stop the Vibration.....	26
Send an Incoming Call to Voicemail	26
Reject an Incoming Call.....	26
Reject an Incoming Call and Send a Message.....	26
In-call Options.....	26
End Phone Calls.....	27
Missed Call Notification	27
Voicemail.....	27
Set Up Voicemail	27
Voicemail Notification	28
New Voicemail Message Alerts	28
Retrieve Your Voicemail Messages.....	28
Phone Call Options	29
Caller ID.....	29
Call Waiting.....	30
3-Way Calling	30
Call Forwarding.....	30
Phone Call Settings.....	31
Call Answer Mode.....	31
Auto-Answer Mode	31
Alert Notification.....	31
Airplane Mode.....	32
TTY Use With Sprint Service	32

Hearing Aid Device Compatibility	33
Sprint Direct Connect.....	34
About Sprint Direct Connect.....	34
Before Making Your First Direct Connect Call.....	34
Your Direct Connect Number	35
Dial Direct Connect Numbers	35
Save a Direct Connect Number	36
Display Your Direct Connect Number	37
Make and Answer Direct Connect Calls.....	37
Make a Direct Connect Call by Entering a Number	37
Make a Direct Connect Call From Contacts	38
Make a Direct Connect Call From History	38
Make a Direct Connect Call Using a Speed Dial Number	39
Make a Direct Connect Call With the Phone Closed	39
Answer Direct Connect Calls	40
End a Direct Connect Call	40
Direct Connect Permissions	41
Call Alerts	42
Send a Call Alert.....	42
Reply to a Call Alert.....	43
Group Connect	43
Make Group Connect Calls.....	43
Group Connect Call Information	45
Invites	45
Send an Invite	45
Reply to an Invite	46
TeamDC	46
Set Up a TeamDC Group	47
Update TeamDC Groups	47
Make a TeamDC Call	47
Remove Yourself from a TeamDC Group.....	48
TeamDC Call Information	48
Settings	49

Display Settings.....	49
Change the Screen Saver	49
Change the Brightness	50
Change the Backlight Settings.....	50
Set the Notification Pop-up	50
Select a Picture ID	50
Power Save Mode	51
Change the Clock/Calendar Display	51
Set a Custom Greeting	51
Change the Phone's Menu Style	51
Change the Font Size	51
Display Language	52
Volume Settings	52
Adjust the Phone's Volume Settings.....	52
Silence All	52
Ringer Settings.....	53
Ringers	53
Set Up Voice Guide	54
Select a Vibration Pattern	54
Messaging Settings.....	55
Set Clear Alerts Icon.....	55
Message Alerts	55
Set a Callback Number.....	55
Add a Customized Signature	55
Manage Preset Messages	56
Long Message Reassembly	56
Phone Setup Options	56
Navigation Key Shortcuts	57
Direct Connect Button.....	57
Keyguard	57
Headset Mode	57
Roaming	58
Roaming on Other Networks	58

Roaming Settings	59
Roaming Guards.....	59
Security Settings	61
Lock Your Phone	61
Limit Use	62
Delete Phone Content	63
Reset Your Phone and Phone Content	64
Security Features for Data Services	64
History	66
View History	66
The History List.....	66
History Icons	66
History Thread	67
History Details.....	67
History Options.....	67
Make a Call From History.....	68
Save the Information in Your History.....	68
Save a Number From History	69
Save a Group From History	69
Make a New Group Entry From History.....	69
Delete History.....	69
Contacts.....	71
About Contacts.....	71
View Contacts	71
The Contacts List.....	72
Contacts Details.....	72
View History From Contacts	72
Create a New Contacts Entry.....	72
Create a Personal Entry	72
Create a Group Entry.....	73
Save a Number Using the Phone Keypad	73
Edit a Contacts Entry.....	74
Edit a Contacts Entry.....	74

Delete a Contacts Entry	74
Add a Number to a Personal Entry	74
Assign a Ringer to a Personal Entry	75
Assign a Picture to a Personal Entry	75
Add Members to a Group Entry	75
Remove Members From a Group Entry.....	76
Find Contacts Entries	76
Find an Entry From Contacts	76
Find an Entry Using the Phone Keypad.....	77
Use Contacts Information in Other Applications.....	77
Assign Speed Dial Numbers	78
Secret Contacts Entries.....	78
Dial Sprint Services	79
Sprint Mobile Sync	79
Messaging.....	81
Text Messaging and Multimedia Messaging	81
Compose Messages	81
Access Messages.....	82
Threaded Messaging	82
Email	84
Calendar & Tools	85
Calendar.....	85
Add an Event to the Calendar.....	85
Add a To Do List Item to the Calendar	86
Calendar Alerts	87
View Events	87
Delete Events	87
Alarm	88
Bluetooth	89
Turn Bluetooth On and Off.....	89
Make Your Phone Discoverable	89
Bluetooth Menu.....	90
Pair Bluetooth Devices	90

View the Trusted Devices List	91
Send Items via Bluetooth.....	91
Voice Services.....	92
Automatic Speech Recognition (ASR).....	92
Manage Voice Memos	95
Calculator	97
World Clock.....	97
Countdown Timer	97
Stopwatch.....	98
Web and Data	99
Data Services	99
Your User Name	99
Launch a Web Connection	100
Data Connection Status and Indicators	100
Browser	100
Learn to Navigate the Web.....	100
Browser Menu.....	102
Download Games, Ringers, and More	104
GPS Navigation	107
GPS Services	107
GPS Navigation.....	107
Sprint Family Locator	108
Copyrights.....	110

Get Started

This section gives you all the information you need to set up your phone and Sprint service the first time.

[Your Phone at a Glance](#)

[Set Up Your Phone](#)

[Activate Your Phone](#)

[Set Up Voicemail](#)

[Sprint Account Information and Help](#)

Your Phone at a Glance

Set Up Your Phone

You must first install and charge the battery to begin setting up your phone.

1. Install the battery.
 - Insert the battery into the battery compartment, making sure the connectors align. Gently press down to secure the battery.
 - Align the tabs of the battery cover with the slots and press the battery cover down until it snaps into place.
 - Slide the battery cover release latch to the locked position.

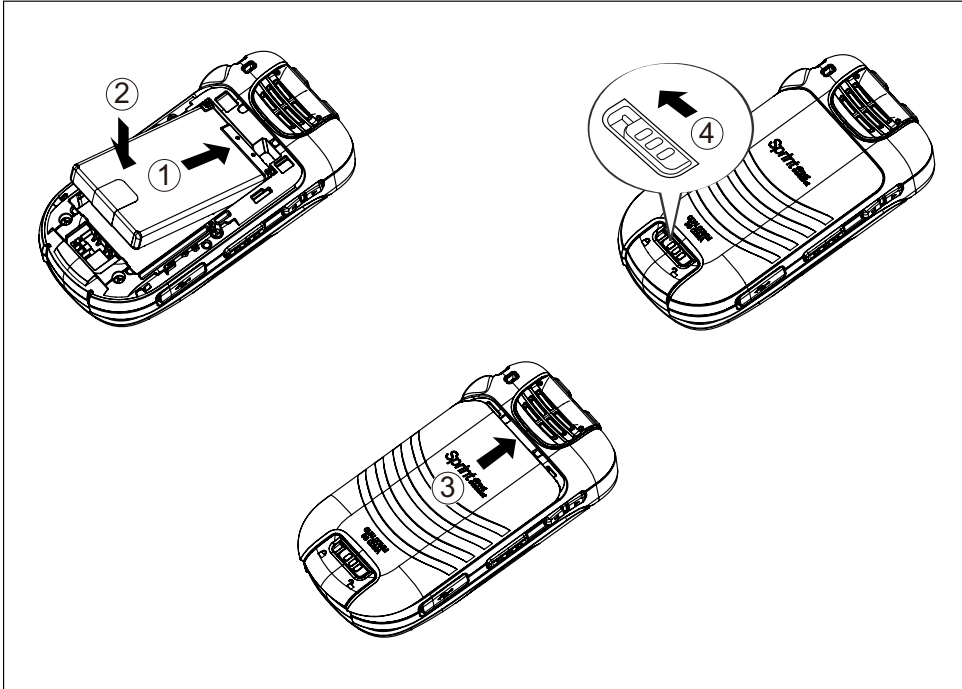

2. Charge your battery.

- Plug the USB connector into the charger/accessory jack on the lower left side of your phone.
- Plug the AC adapter into an electrical outlet.

Note: Your phone's battery should have enough charge for your phone to turn on and find a signal, set up your voicemail, and make a call. You should fully charge your battery as soon as possible.

3. Press  to turn the phone on.



- If your phone is activated, it will search for Sprint service and enter standby mode.
- If your phone is not yet activated, see [Activate Your Phone](#) for more information.

Activate Your Phone

Depending on your account or how and where you purchased your phone, it may be ready to use or you may need to activate it on your Sprint account.

- If you purchased your phone at a Sprint Store, it is probably activated and ready to use.

- If you received your phone in the mail and it is for a new Sprint account or a new line of service, it is designed to activate automatically.
- If you received your phone in the mail and you are activating a new phone for an existing number on your account (you're swapping phones), you can activate on your computer online or directly on your phone.
 - **Activate on your computer:**
 - Go to sprint.com/activate and follow the instructions to activate your phone.
 - **Activate on your phone:**
 - Turn on your new phone. (Make sure the old one is turned off.) Your phone will automatically attempt Hands-Free Activation. Follow the onscreen prompts to complete the activation process.
 - If an error occurs, press **ACTIVATE** (left softkey) to override auto-activation and start the manual activation wizard. Follow the onscreen prompts to complete the activation process.
- To confirm activation, make a phone call. If your phone is still not activated or you do not have access to the Internet, contact Sprint Customer Service at **1-888-211-4727** for assistance.

Tip: Do not press  while the phone is being activated. Pressing  cancels the activation process.

Note: If you are having any difficulty with activation, contact Sprint Customer Service by calling **1-888-211-4727** from any other phone.

Set Up Voicemail

Your phone automatically transfers all unanswered calls to your voicemail, even if your phone is in use or turned off. You should set up your Sprint Voicemail and personal greeting as soon as your phone is activated. Always use a password to protect against unauthorized access.

1. Press and hold  in standby mode to dial your voicemail number.
2. Follow the system prompts to:
 - Create your password.
 - Record your name announcement.
 - Record your greeting.

Note: Voicemail Password – Sprint strongly recommends that you create a password when setting up your voicemail to protect against unauthorized access. Without a password, anyone who has access to your phone is able to access your voicemail messages.

Sprint Account Information and Help

Find out about account passwords and information about managing your account and finding help.

[Sprint Account Passwords](#)

[Manage Your Account](#)

[Sprint Support Services](#)

Sprint Account Passwords

As a Sprint customer, you enjoy unlimited access to your personal account information, your voicemail account, and your data services account. To ensure that no one else has access to your information, you will need to create passwords to protect your privacy.

Account User Name and Password

If you are the account owner, you will create an account user name and password when you sign on to [sprint.com](#). (Click **Sign in/Sign up** and then click **Sign up now!** to get started.) If you are not the account owner (if someone else receives the bill for your Sprint service), you can get a sub-account password at [sprint.com](#).

Voicemail Password

You'll create your voicemail password when you set up your voicemail. See [Set Up Voicemail](#) for more information on your voicemail password.

Data Services Password

With your Sprint phone, you may elect to set up an optional data services password to control access and authorize Premium Service purchases.

For more information, or to change your passwords, sign on to [sprint.com](#) or call Sprint Customer Service at **1-888-211-4727**.

Manage Your Account

Manage your Sprint account from your computer, your Sprint phone, or any other phone.

Online: [sprint.com](#)

- Access your account information.
- Check your minutes used (depending on your Sprint service plan).
- View and pay your bill.
- Enroll in Sprint online billing and automatic payment.

- Purchase accessories.
- Shop for the latest Sprint phones.
- View available Sprint service plans and options.
- Learn more about data services and other products like games, ringers, screen savers, and more.

From Your Sprint Phone

- Press ***#*# 4#* TALK** to check minute usage and account balance.
- Press ***#*# 3#* TALK** to make a payment.
- Press ***#*# 2#* TALK** to access a summary of your Sprint service plan or get answers to other questions.

From Any Other Phone

- Sprint Customer Service: **1-888-211-4727**.
- Business Customer Service: **1-888-788-4727**.

Sprint Support Services

Sprint 411

Sprint 411 gives you access to a variety of services and information, including residential, business, and government listings; movie listings or showtimes; driving directions, restaurant reservations, and major local event information. You can get up to three pieces of information per call, and the operator can automatically connect your call at no additional charge.

There is a per-call charge to use Sprint 411, and you will be billed for airtime.

Press **4#* 1# 1# TALK**.

Sprint Operator Services

Sprint Operator Services provides assistance when you place collect calls or when you place calls billed to a local telephone calling card or third party.

Press **0#* TALK**.

For more information or to see the latest in products and services, visit us online at sprint.com.

Phone Basics

Your phone is packed with features that simplify your life and expand your ability to stay connected to the people and information that are important to you. The topics in this section will introduce the basic functions and features of your phone.

Tip: Phone Software Upgrades - Updates to your phone's software may become available from time to time. Sprint will automatically upload critical updates to your phone. You can also use the menu to check for and download updates. Press  > **Tools > Update Phone > Update Firmware** to search for and download available updates.

[Your Phone's Layout](#)

[Turn Your Phone On and Off](#)

[Battery and Charger](#)

[View the Display Screen](#)

[Navigate Through the Menus](#)

[Display Your Phone Number](#)

[Enter Text](#)

[Simple Data Exchange](#)

Your Phone's Layout



Key Functions

- **Earpiece** lets you hear the caller and automated prompts.
- **Main Screen** displays all the information needed to operate your phone, such as the call status, the Contacts list, the date and time, and the signal and battery strength.
- **Softkeys** let you select softkey actions or menu items corresponding to the bottom left and right lines on the main screen while the phone is open.
- **Navigation Key** lets you scroll through the phone's menu options.
- **MENU/OK Key** lets you access the phone's menus and selects the highlighted choice when navigating through a menu.

- **Camera Key** lets you activate the camera or video mode and take pictures and videos with the phone open.
- **TALK Key** allows you to place or receive calls, answer Call Waiting, use Three-Way Calling, or activate Automatic Speech Recognition (ASR).
- **SPEAKER Key** lets you place or receive calls in speakerphone mode or turn the speakerphone on and off during a call.
- **Microphone** allows other callers to hear you clearly when you are speaking to them.
- **BACK Key** deletes characters from the display in text input mode. When in a menu, pressing it returns you to the previous menu. This key also allows you to return to the previous screen in a data session.
- **END/POWER Key** lets you turn the phone on or off, end a call, or cancel your input and return to standby mode.
- **Keypad** lets you enter numbers, letters, and characters, and perform functions.
- **Internal Antenna** facilitates reception and transmission. To maximize performance, do not touch the bottom portion of your phone where the internal antenna is located while using the phone.
- **Call List Button** lets you display the recent call history or end a call.
- **External Speaker Button** lets you place or receive calls in speakerphone mode, turn the speakerphone on and off during a call, activate Automatic Speech Recognition (ASR), or unlock the keyguard.
- **Volume Button** allows you to adjust the ringer volume in standby mode or the voice volume during a call.
- **Speaker** lets you hear the different ringers and sounds. The speaker also lets you hear the caller's voice in speakerphone mode.
- **Direct Connect Button (DC Button)** allows you to make Direct Connect calls, send Call Alerts, and view Direct Connect call history. See [Sprint Direct Connect](#).
- **Outer Screen** displays the information such as the call status, the date and time, and the signal and battery strength.
- **Charger/Accessory Jack** allows you to connect a compatible charging cable or USB data cable (not included).

CAUTION! Inserting an accessory into the incorrect jack may damage the phone.

- **LED Indicator** shows your phone's status at a glance.
- **Camera Lens**, as part of the built-in camera, lets you take pictures and videos.
- **Flash** allows you to take pictures in low light situations.
- **Headset Jack** allows you to plug in an optional headset for convenient, hands-free conversations.

CAUTION! Inserting an accessory into the incorrect jack may damage the phone.

- **Battery Cover Release Latch** opens the battery cover to replace the battery.

Turn Your Phone On and Off

Turn Your Phone On

- Open the phone and press .

Turn Your Phone Off

- Open the phone and press and hold  for two seconds until you see the powering-down animation on the main screen.

Your screen remains blank while your phone is off (unless the battery is charging).

Battery and Charger

Warning: Use only Sprint-approved or Kyocera-approved batteries and chargers with your phone. The failure to use a Sprint-approved or Kyocera-approved battery and charger may increase the risk that your phone will overheat, catch fire, or explode, resulting in serious bodily injury, death, or property damage.

Sprint-approved or Kyocera-approved batteries and accessories can be found at Sprint Stores or through Kyocera; or call 1-866-866-7509 to order. They're also available at sprint.com.

Battery Capacity

Your phone is equipped with a Lithium Ion (Li-Ion) battery. It allows you to recharge your battery before it is fully drained.

For a quick check of your battery level, glance at the battery charge indicator located in the upper right corner of your phone's display screen. When there are approximately five minutes of talk time left, the battery icon turns red and the phone sounds a warning tone.

After an additional five minutes or so, the phone sounds a warning tone three times and then turns off.

Note: Long backlight settings, searching for service, vibrate mode, browser use, and other variables may reduce the battery's talk and standby times.

Tip: Watch your phone's battery level indicator and charge the battery before it runs out of power.

Install the Battery

See [Set Up Your Phone](#).

Remove the Battery

1. Make sure the power is off so that you don't lose any stored numbers or messages.
2. Slide the battery cover release latch to the right to unlock the cover.
3. Slide your thumbnail or a coin under the slot on either side of the phone and pop off the cover.
4. Remove the battery and replace the cover. See [Set Up Your Phone](#).

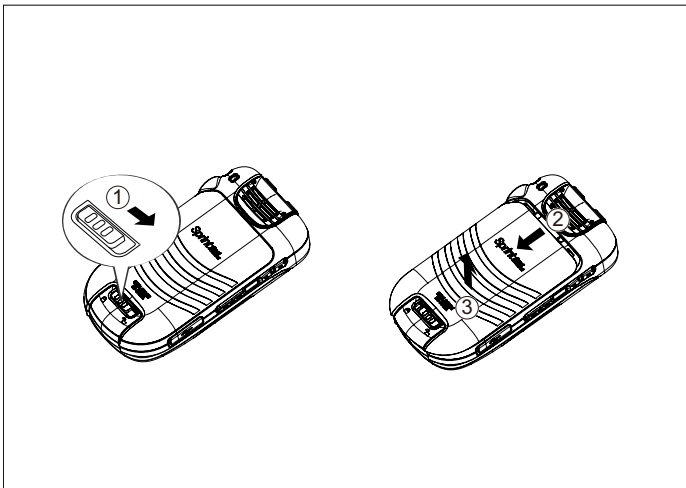

Warning: Do not handle a damaged or leaking Li-Ion battery as you can be burned.

View the Display Screen

The status bar at the top of your phone's display screen provides information about your phone's status and options. The following tables identify the symbols you'll see on your phone's display screen.

Tip: To view a list of your phone's icons and descriptions, from the main menu select **Settings > Phone Info > Icon Glossary**.

Service Icons	Description
	Signal Strength - Your phone's current signal strength. (More bars = stronger signal.)

	No Service - Your phone cannot find a usable signal.
	Roaming - Your phone is “roaming” off the Nationwide Sprint Network.
	DC Unavailable - Direct Connect services are unavailable in your current location.
	Data Service Available - Sprint data service is available. When active, the icon is animated.
	Data Service Dormant - Sprint data service is currently dormant.
	Data Service Unavailable - Sprint data service is currently unavailable.

Status Icons	Description
	Battery - Your phone’s current battery charge level. (The icon to the left shows the battery is fully charged.) The icon is animated while the battery is charging.
	Location On - Your phone’s location feature is on and available for location-based services such as GPS Navigation.
	Location Off - Your phone’s location feature is off. Your location is available only for 911.
	Silence All - Your phone’s sound is turned off.
	Vibrate All - Your phone’s sound is turned off but vibrate is turned on.
	Ringer Off - Your phone’s ringer is turned off.
	1 Beep - A beep sounds when you receive an incoming call, a message, etc.
	1 Beep and Vibrate - 1 Beep and vibrate are set.
	Ringer and Vibrate - The volume level is set to between 1 and 8 and vibrate is turned on.
	DC Speaker On - The speakerphone is on for Direct Connect calls.
	DC Speaker Off - The speakerphone is off for Direct Connect calls. The earpiece or an optional headset must be used to hear DC calls.

Messaging and Alert Icons	Description
	New Messages - You have one or more new messages waiting.
	New Voicemail - You have one or more new voicemail messages waiting.

	Urgent Messages - You have one or more new urgent messages waiting.
	Multiple Alerts - You have different kinds of alerts waiting.
	Urgent Multiple Alerts - You have different kinds of alerts (including urgent messages) waiting.
	Application Alerts - You have alert messages from Java applications activated in the background.
	Call Alert - You have a Direct Connect Call Alert waiting. Press the DC button to reply to the alert.

Bluetooth Icons	Description
	Visible - Your phone is discoverable by (visible to) other Bluetooth devices.
	Connected - Your phone is connected to a Bluetooth device.
	Enabled - Your phone's Bluetooth feature is enabled.
	Connected via HFP - Your phone is connected to or communicating with a Bluetooth device via Hands-free Profile (HFP).

Note: The above icons will blink while your phone is communicating with a Bluetooth device.

Voice Call Icons	Description
	Missed Call - You have one or more missed voice calls.
	Missed DC Call - You have one or more missed Direct Connect calls, or your group is updated.
	Bluetooth Device - A call is in progress using a Bluetooth device.
	Headset - A call is in progress using an optional wired headset.
	Car Kit - A call is in progress using an optional car kit device.

Other Icons	Description
	TTY - Your phone is connected to a TTY device.
	Alarm - An alarm or countdown is set.
	Calendar - You have event notifications.
	HAC Enabled - Your phone's HAC (hearing aid compatibility) setting is enabled.

	<p>Multitasking Virtual Machine - Java applications are running. The number next to the plus sign indicates the number of running applications.</p>
--	--

Navigate Through the Menus





The navigation key on your phone lets you scroll through onscreen items. To navigate through a menu, press the navigation key up or down.

Many menus feature a scroll bar on the right to help you keep track of your position in the menu.

Select Menu Items

As you navigate through the menu, menu options are highlighted. Select any option by highlighting it and pressing . If the option is numbered, you can select it by pressing the corresponding number on the phone's keypad.

For example, to view the Icon Glossary screen:

1. Press  to access the main menu.
2. Select **Settings** by highlighting it and pressing .
3. Select **Phone Info** by highlighting it and pressing .
4. Select **Icon Glossary** by highlighting it and pressing .

For the purposes of this guide, the above steps condense into:

- Press  > **Settings** > **Phone Info** > **Icon Glossary**.

Back Up Within a Menu

To go to the previous menu:

- Press .

To return to standby mode:

- Press .

Display Your Phone Number

- Press  > **Settings** > **Phone Info** > **Phone#/User ID**.

Your phone number and other information about your phone and account will be displayed.

Enter Text

You can type on your phone using various input modes.

Select a Text Input Mode

T9 Text Input

ABC Mode

Set Text Entry Options

Select a Text Input Mode

Your phone provides convenient ways to enter letters, numbers, and symbols whenever you are prompted to enter text.

1. From a screen where you can enter text, press **OPTIONS** (right softkey) to change the text mode. (If you are in the message entry screen, press **OPTIONS** [right softkey] > **Text Mode**.)
2. Select one of the following options:
 - **Abc** to enter characters by using the alphabet mode. See [ABC Mode](#).
 - **T9Word** to enter text using a predictive text system that reduces the number of key presses required while entering a word.
 - **123** to enter numeric characters.
 - **Symbols** to enter symbols.
 - **Smileys** to enter smile icons.
 - **Emoticons** to enter “emoticons.” (This is available, for example, when composing a message or when editing a Schedule or To Do description in Calendar.)
 - **Paste List** to paste copied or cut text (if applicable).
 - **Web Shortcuts** to enter Web shortcuts (for example, www., http://, or .com).
 - **Text Options** to display the text entry options menu (if applicable). See [Set Text Entry Options](#).

Tip: When entering text, press  to change the capitalization style as **Abc** > **ABC** > **abc** (ABC mode), or as **T9Word** > **T9WORD** > **T9word** (T9Word mode). The selected style is displayed in the bottom-right corner of the screen, above the right softkey label (if applicable).

T9 Text Input

T9 Text Input lets you enter text by pressing keys just once per letter. To select the **T9 Word** mode when entering text, see [Select a Text Input Mode](#).

T9 Text Input uses an intuitive word database to analyze the letters you enter and create a suitable word. (The word may change as you type.)

1. Select the **T9Word** text input mode.
2. Press the corresponding keys once per letter to enter a word. (For example, to enter the word “Bill,” press **2** **4** **5** **5**.) (If you make a mistake, press **BACK** to erase a single character. Press and hold **BACK** to erase an entire word.)

If the word you want is not displayed after you have entered all the letters, press the navigation key to scroll through additional word selections. To accept a word and insert a space, press **SPACE**.

Add a Word to the T9 Database

If a word you want to enter is not displayed in a T9 word choice list when you are using T9 Input, add it to the database.

1. While you are in **T9Word** mode, enter a letter. (A word choice list opens.)
2. Scroll down the list and select **<Add Word>**.
3. Enter a word and press **SAVE** (left softkey). The word will appear as an option the next time you scroll through options during T9 Text Input.

For more information about T9 Text Input, visit the Nuance website at nuance.com/t9/xt9/.

ABC Mode

In **Abc** mode, also known as multi-tap entry, you press keys one, two, three, or four times to enter the letters you see on the keypad.

By default, the first letter of a sentence is capitalized and the following letters are lowercased. To switch between lowercase and uppercase, press the **SHIFT** key. After a character is entered, the cursor automatically advances to the next space after two seconds or when you enter a character on a different key.

1. Select the **Abc** text input mode. See [Select a Text Input Mode](#).
2. Press the corresponding key repeatedly until the correct letter appears. For example, to enter “Abc,” press **2** once for “a,” twice for “b,” and three times for “c.”

Set Text Entry Options

The text entry options menu allows you to specify a suitable feature during the text entry process.

1. When entering text, press **OPTIONS** (right softkey) > **Text Options**.

– or –

Press  > **Settings** > **Text Entry**.

2. Highlight an option and press .

- **Word Complete** to suggest possible words based on letters you have entered when the T9 mode is enabled.
- **Next Word Complete** to automatically display the word that may follow the current text input.
- **Phrase Complete** to set the phone to predict possible phrases after one word with a space is entered.
- **Word Scan** to allow the predictive text input system to recognize words by searching Contacts.
- **Word Choice List** to select whether to display the word choice list.
- **Input Language** to select the language to enter (English or Spanish).
- **My Words** to edit or delete custom words you have added to the predictive text database.
 - **Add Word** to store words that you frequently use.
- **Select Text** to select text for copying, cutting or adding (if applicable).
- **Delete All** to delete all text (if applicable).
- **Help** to view the T9 instructions.

Simple Data Exchange

This feature makes it easy to select certain information in a message and automatically save it or use it in a related application.

Simple Data Exchange works with these types of information:

- Email addresses
- Street addresses
- Phone numbers and Direct Connect numbers
- Web addresses (URLs)

Email Address Options

Highlight an email address, press , and then select an option:

- **Send Message** to select **Message**. The messaging application will open and the email address will appear as the message's recipient.
- **Share** to select **Message**. The messaging application will open and the email address will appear in the message body.
- **Save to Contacts** to save the email address in Contacts.
- **Contact Details** to display the Contacts entry if the email address is already saved in Contacts.

Street Address Options

Highlight a street address, press , and select an option:

- **Navigate** to show directions to the address using Sprint Navigation.
- **Map** to show the address location on a map.
- **Share** to select **Message**. The messaging application will open and the address will appear in the message body.
- **Save to Contacts** to save the address in Contacts.

Phone Number Options

Highlight a phone number, press , and then select an option:

- **Call** to call the phone number.
- **Direct Connect** to call the Direct Connect number.
- **Call Alert** to send a Call Alert.
- **Prepend** to prepend a number to the phone number.
- **Send Message** to send a message to the phone number. The messaging application will open and the phone number will appear in the **To:** field.
- **Share** to select **Message**. The messaging application will open and the phone number will appear in the message body.
- **Save to Contacts** to save the phone number in Contacts.
- **Contact Details** to display the Contacts entry if the phone number is already saved in Contacts.

Web Address (URL) Options

Highlight a Web address (URL), press , and select an option:

- **Browse** to open the browser to the Web page.
- **Share** to select **Message**. The messaging application will open and the Web address will appear in the message body.
- **Save to Contacts** to save the Web address in Contacts.

Phone Calls & Settings

With the Nationwide Sprint Network, you can enjoy clear calling across the country. This section explains the features related to phone calls.

[Make Phone Calls](#)

[Receive Phone Calls](#)

[End Phone Calls](#)

[Missed Call Notification](#)

[Voicemail](#)

[Phone Call Options](#)

[Phone Call Settings](#)

Note: The calling information in this section refers to traditional wireless phone calls. For information on making and answering Direct Connect calls, Group Connect calls, and TeamDC calls, see [Sprint Direct Connect](#).

Make Phone Calls

There are several convenient ways to place calls from your phone.

[Call Using the Phone Keypad](#)

[Call With the Phone Closed](#)

[Call From History](#)

[Call From Contacts](#)

[Call Using the Plus \(+\) Code](#)

[Call Using a Speed Dial Number](#)

[Call Using Abbreviated Dialing Features](#)





[Call a Phone Number With Pauses](#)

[Call a Phone Number in a Message](#)

[Call Emergency Numbers](#)

Call Using the Phone Keypad

The most “traditional” way to place a call is by using the phone’s keypad.

1. Enter a phone number from standby mode. (If you make a mistake while dialing, press  to erase the numbers.)
2. Press , , or the external speaker button.
3. Press  when you are finished.

Call With the Phone Closed



You can make a phone call using Automatic Speech Recognition (ASR) with the phone closed. It also works with the phone open. See [Automatic Speech Recognition \(ASR\)](#).

1. Press and hold the external speaker button to unlock the keyguard if the buttons are locked. See [Keyguard](#).
2. Press and hold the external speaker button to activate ASR.
3. Follow the voice prompts. Say “Call” and the name of an entry saved in your Contacts or a phone number. See [Make a Voice Call Using ASR](#).
 - The call will be made in speakerphone mode unless you have a headset connected to the phone.
4. Press the call list button when you are finished.

Tip: You can redial your most recent call using the Recent Calls list. Press the call list button to display the list and select the entry you want to call.

Call From History

Place a call to the numbers in your History.

1. Press  > **History**.
– or –
Press  or the call list button in standby mode.
2. Highlight an entry and press .

Tip: To redial your last outgoing call, press  twice.

Note: You cannot make calls from History to entries identified as **No Caller ID**, **Private (Restricted ID)**, or **Unavailable ID**.



Call From Contacts

Place a call to the numbers stored in your Contacts.

1. From standby mode, press **CONTACTS** (right softkey).
2. Highlight the entry you want to call.



3. Press  to dial the entry's default phone number.

– or –

To dial another number from the same entry, press  to select the entry, highlight a number, and then press .

Call Using the Plus (+) Code

When placing international calls, use Plus Code Dialing to automatically enter the international access code for your location (for example, 011 for international calls made from the U.S.).

1. Press and hold  to display “+” on your phone screen.
2. Enter the country code and phone number, and then press . (The phone automatically prepends the access code for international dialing, followed by the country code and phone number.)

Call Using a Speed Dial Number

You can store up to 98 numbers in your phone's speed dial memory to make contacting friends and family easier.

You must have already assigned a speed dial number to an existing phone number. See [Assign Speed Dial Numbers](#).

To use speed dial for locations 2-9:

1. From standby mode, press and hold the appropriate key for approximately two seconds.

To use speed dial for locations 10-99:

1. From standby mode, enter a two-digit speed dial number, and then press .

The display confirms that the number has been dialed when it shows “Connecting...”

Call Using Abbreviated Dialing Features

Abbreviated Dialing is similar to speed dialing. You can use either of the following abbreviated dialing features.

- **Contacts Match** - Retrieve any number saved in your Contacts by entering four or more digits of any part of the number.
- **Prepend** - Prepend the first five or six digits (for example, the area code and prefix) to any four or five digits you enter.

To activate the Prepend feature:

1. Press  > **Settings** > **Others** > **Call Setup** > **Abbrev. Dial**.

2. Select **Prepend > On**.
3. Enter a five- or six-digit number and press .



To place a call using Abbreviated Dialing:

1. Enter the four or more digits of any part of a Contacts entry's phone number to use the Contacts Match feature.

– or –

Enter the last four or five digits of the number to use the Prepend feature.

Note: Contacts Match will not retrieve numbers if you enter 911 or reserved three-digit service numbers such as 411 or 711.

2. Press  to call the displayed number. (If there are two or more matched numbers in your Contacts, a list is displayed. Highlight the name or the phone number you want to call, and then press  to place a call.)

Call a Phone Number With Pauses

You can dial or save phone numbers with pauses for use with automated systems, such as voicemail or credit card billing numbers.

There are two types of pauses available on your phone:

- **Hard Pause** sends the next set of numbers when you press **SEND TONES** (left softkey).
- **2-Sec. Pause** automatically sends the next set of numbers after two seconds.

Note: You can have multiple pauses in a phone number and combine two-second and hard pauses.

To dial or save phone numbers with pauses:

1. Enter all or part of a number.
2. Press **OPTIONS** (right softkey) > **Hard Pause** or **2-Sec. Pause**.
3. Enter additional numbers.
4. Press  to dial the number.

Note: When dialing a number with a hard pause, press **SEND TONES** (left softkey) to send the next set of numbers.

Call a Phone Number in a Message

You can place a call to a number that appears in a message.

1. In standby mode, press **MESSAGING** (left softkey) > **Messages**.

2. Select a message with the number you want to call.
3. Select the number and select **Call**.

For more information on utilizing the information in a message, see [Simple Data Exchange](#).

Call Emergency Numbers

You can place calls to 911 even if your phone is locked or your account is restricted.

Press    .

Note: After you have placed an emergency call, your phone automatically enters Emergency mode.

During an emergency call, press **OPTIONS** (right softkey) to display your options. Highlight an option and press .

- **Transfer Audio** to switch the call to an external device (if applicable).
- **Contacts** to show the Contacts list.
- **Voice Memo** to record the other party's voice.
- **Phone Info** to display information about your phone.

Tip: Press **MY PHONE#** (left softkey) to display your phone number during an emergency call.

To exit emergency mode:

1. Press  to end a 911 call.
2. Press  .

Enhanced 911 (E911) Information

This phone features an embedded Global Positioning System (GPS) chip necessary for utilizing E911 emergency location services where available.

When you place an emergency 911 call, the GPS feature of your phone seeks information to calculate your approximate location. Depending on several variables, including availability and access to satellite signals, it may take up to 30 seconds or more to determine and report your approximate location.

Important: Always report your location to the 911 operator when placing an emergency call. Some designated emergency call takers, known as Public Safety Answering Points (PSAPs) may not be equipped to receive GPS location information from your phone.

Receive Phone Calls

Your phone notifies you of incoming calls in the following ways:

- The phone rings or vibrates.
- The LED indicator flashes.
- The backlight illuminates.
- The screen displays an incoming call message.

If the incoming call is from a number stored in your Contacts, the entry's name is displayed. The caller's phone number may also be displayed, if available.

Note: If your device is turned off, all calls automatically go to voicemail.

[Answer an Incoming Call With the Phone Open](#)

[Answer an Incoming Call With the Phone Closed](#)

[Answer an Incoming Call in Speakerphone Mode](#)

[Answer a Roam Call With Roaming Guards Enabled](#)

[Mute the Ringer and Stop the Vibration](#)

[Send an Incoming Call to Voicemail](#)

[Reject an Incoming Call](#)

[Reject an Incoming Call and Send a Message](#)

[In-call Options](#)

Answer an Incoming Call With the Phone Open

- Press  to answer an incoming call. (Depending on your settings, you may also answer incoming calls by pressing other keys. See [Call Answer Mode](#).)

Answer an Incoming Call With the Phone Closed

- When your phone rings or vibrates, press the external speaker button. (The call will be answered in speakerphone mode.)

– or –

Open the phone to use the earpiece. See [Call Answer Mode](#).

Answer an Incoming Call in Speakerphone Mode

- Press  or the external speaker button.

Answer a Roam Call With Roaming Guards Enabled

1. Press **TALK**.
2. Read the message and press **END**.

See [Roaming Guards](#) for more information on Roaming Guards.

Mute the Ringer and Stop the Vibration

- Press **Silence** on the screen.
- or –
- Press **BACK**, the DC button, or the volume button up or down.

Send an Incoming Call to Voicemail

- Press **Send to Voicemail** on the screen.

Reject an Incoming Call

- Press **END** or the call list button.
- or –
- Press and hold **BACK**.

Reject an Incoming Call and Send a Message

- Press **Ignore with Text**.

In-call Options

Pressing **OPTIONS** (right softkey) during a call displays a list of available in-call features. To select an option, highlight the option and press **OK**.

- **Transfer Audio** to switch the call to a Bluetooth device (if applicable).
- **Save** to save the current call's phone number in your Contacts.
- **Contact Details** to display information about the caller stored in your Contacts.
- **Main Menu** to display the phone's main menu.
- **3-Way Call** to open a call with two other parties.
- **Contacts** to display your Contacts list.
- **Voice Memo** to record the other party's voice.
- **Phone Info** to display information about your phone.

- Press **MUTE/UNMUTE** (left softkey) to mute/unmute the microphone.
- Press the volume button up or down to adjust the receiver volume.
- Press  or the external speaker button to turn the speaker on. Press again to turn it off.

Warning: Because of higher volume levels, do not place the phone near your ear during speakerphone use.

End Phone Calls



- Press  or the call list button.

After you have finished your call, the phone will display the caller's name (if already in your Contacts), phone number (if available), and the duration of the call. Pressing **OPTIONS** (right softkey) will display the Recent History options. See [History Options](#) for details.

Missed Call Notification

When an incoming call is not answered, your screen displays the Missed Call log. Press  to dial the phone number.

To display a Missed Alerts entry from standby mode:

1. Press  > **Missed Alerts**.
2. Highlight the entry you wish to view and press .

Voicemail

Your phone automatically transfers all unanswered calls to your voicemail, even if your phone is in use or turned off. You should set up your Sprint Voicemail and personal greeting as soon as your phone is activated. Always use a password to protect against unauthorized access.

[Set Up Voicemail](#)

[Voicemail Notification](#)

[New Voicemail Message Alerts](#)

[Retrieve Your Voicemail Messages](#)

Set Up Voicemail

1. Press and hold  in standby mode to dial your voicemail number.
2. Follow the system prompts to:
 - Create your password.
 - Record your name announcement.

- Record your greeting.

Important: **Voicemail Password** – Sprint strongly recommends that you create a password when setting up your voicemail to protect against unauthorized access. Without a password, anyone who has access to your phone is able to access your voicemail messages.

Voicemail Notification

There are several ways your phone alerts you to a new message:

- By displaying a message on the screen.
- By sounding the assigned ringer type.
- By displaying at the top of the screen.

New Voicemail Message Alerts

When you receive a new voicemail message, your phone alerts you and prompts you to call your voicemail.

To call your voicemail from the notification screen:

1. Press .
2. Enter your voicemail password if prompted.
3. Follow the voice prompts to listen to and manage your voicemail messages.

Note: When you are roaming off the Nationwide Sprint Network, you may not receive notification of new voicemail messages. Sprint recommends that you periodically check your voicemail. See [Check for Voicemail Messages While Roaming](#). Roaming rates apply when you access voicemail while roaming off the Nationwide Sprint Network.

Note: Your phone accepts messages even when it is turned off. However, your phone notifies you of new messages **only** when it is turned on and you are in a Sprint service area.

To set the frequency of new message alerts:

1. Press  > **Settings** > **Others** > **Alerts** > **Repeated Tone** > **Voicemail**.
2. Select **Single Tone** (once only) or **Repeated Tone** (once every minute).

Retrieve Your Voicemail Messages

You can review your messages directly from your wireless phone or from any other touch-tone phone.

Use Your Phone to Access Your Messages

1. Press and hold .

– or –

In standby mode, press **MESSAGING** (left softkey) > **Voicemail**.

2. Enter your voicemail password if prompted.
3. Follow the voice prompts to listen to and manage your voicemail messages.

Note: You are charged for airtime minutes when you are accessing your voicemail from your wireless phone.

Use Another Phone to Access Messages

1. Dial your wireless phone number.
2. When your voicemail answers, press  (the star key).
3. Enter your password.

Tip: When you call into voicemail, you first hear the header information (date, time, and sender information) for the message. To skip directly to the message, press  during the header.

Phone Call Options

Your phone application provides many useful features and options to help you make the most of your calling experience.

[Caller ID](#)





[Call Waiting](#)

[3-Way Calling](#)

[Call Forwarding](#)

Caller ID

Caller ID identifies a caller before you answer the phone by displaying the number of the incoming call. If you do not want your number displayed when you make a call, follow these steps.

1. Enter   .
2. Enter the number you want to call.
3. Press .

To permanently block your number, call Sprint Customer Service.

Call Waiting

When you're on a call, Call Waiting alerts you to incoming calls by sounding a beep. Your phone's screen informs you that another call is coming in and displays the caller's phone number (if available).

To respond to an incoming call while you're on a call:

- Press **TALK**. (This puts the first caller on hold and answers the second call.)

To switch back to the first caller:

- Press **TALK** again.

Tip: For those calls where you don't want to be interrupted, you can temporarily disable Call Waiting by pressing ***33# 7## 0*** before placing your call. Call Waiting is automatically reactivated once you end the call.

3-Way Calling

With 3-Way Calling, you can talk to two people at the same time. When using this feature, the normal airtime rates will be charged for each of the two calls.

1. Enter a number and press **TALK**.
2. Once you have established the connection, press **TALK**. (This puts the first caller on hold.)
3. Select **Contacts**, **Recent History**, or **Enter Phone#**.
4. Select a number from your Contacts or Recent History, or enter a number directly, and then press **TALK**.
5. When you're connected to the second party, press **TALK** again to begin your 3-way call.

If one of the people you called hangs up during your call, you and the remaining caller stay connected. If you initiated the call and are the first to hang up, all callers are disconnected.

Call Forwarding

Call Forwarding lets you forward all your incoming calls to another phone number—even when your phone is turned off. You can continue to make calls from your phone when you have activated Call Forwarding.

Note: You are charged a higher rate for calls you have forwarded.

To activate Call Forwarding:

1. Enter ***33# 7## 2##**.
2. Enter the area code and phone number to which you want your calls forwarded.
3. Press **TALK**. (You will hear a tone to confirm the activation of Call Forwarding.)

To deactivate Call Forwarding:

1. Enter *33*7*2*0*.
2. Press TALK (You will hear a tone to confirm the deactivation.)

Phone Call Settings

Various call-related settings are available.

[Call Answer Mode](#)

[Auto-Answer Mode](#)

[Alert Notification](#)

[Airplane Mode](#)

[TTY Use With Sprint Service](#)

[Hearing Aid Device Compatibility](#)

Call Answer Mode

Select how to answer incoming calls on your phone.

1. Press MENU > **Settings** > **Others** > **Call Setup** > **Call Answer**.
2. Select **Talk Key**, **Any Key**, or **Flip Open**.

Auto-Answer Mode

Set your phone to automatically pick up incoming calls. Remember, your phone will answer calls in auto-answer mode even if you are not present.

1. Press MENU > **Settings** > **Others** > **Call Setup** > **Auto-Answer**.
2. Highlight an option and press.
 - **Hands-free** to answer calls automatically when the phone is connected to an optional headset or hands-free device.
 - **Speakerphone** to answer calls automatically in speakerphone mode.
3. Highlight the time you would like your phone to wait before answering and press.

Alert Notification

Set your phone to alert you with an audible tone when you change service areas, once a minute during a voice call, or when a call has been connected.

1. Press MENU > **Settings** > **Others** > **Alerts**.

2. Select **Beep Each Minute**, **Out of Service**, or **Connect**.
3. Select **On** or **Off**.

Airplane Mode

Airplane Mode allows you to use many of your phone's features, such as games and voice memos, when you are on an airplane or in any other area where making or receiving calls or data is prohibited. When you set your phone to Airplane Mode, it cannot send or receive any calls or access online information.

1. Press > **Settings** > **Others** > **Airplane Mode**.
2. Read the disclaimer and press.
3. Select an option from the following:
 - **On** to activate Airplane Mode. Airplane Mode will be deactivated when you turn the phone off.
 - **Off** to deactivate Airplane Mode.
 - **On Power-up** to activate Airplane Mode each time you turn the phone on.

While in Airplane Mode, your phone's screen will display "Phone Off."

TTY Use With Sprint Service

A TTY (also known as a TDD or Text Telephone) is a telecommunications device that allows people who are deaf, hard of hearing, or who have speech or language disabilities to communicate by telephone.

Your phone is compatible with select TTY devices. Please check with the manufacturer of your TTY device to ensure that it is compatible with digital cell phones. Your phone and TTY device will connect via a special cable that plugs into your phone's headset jack. If this cable was not provided with your TTY device, contact your TTY device manufacturer to purchase the connector cable.

To turn TTY Mode on or off:

1. Press > **Settings** > **Others** > **Accessibility** > **TTY**. (You will see an informational message.)
2. Press.
3. Select one of the following options:
 - **TTY Off** to disable TTY mode.
 - **TTY VCO** to enable TTY mode in Voice Carry Over mode, which allows you to send voice and receive text during a call.

- **TTY HCO** to enable TTY mode in Hearing Carry Over mode, which allows you to send text and receive voice during a call.
- **TTY Full** to enable all TTY settings. You can send and receive text during a call.

To access the state Telecommunications Relay Service (TRS) for assistance with TTY calls:

Dial      and press  to reach an operator.

For additional information about Sprint Relay Services and TTY compatibility, call Sprint Relay Customer Service at **800-676-3777** or visit sprintrelay.com.

Note: In TTY Mode, your phone will display the TTY icon if a TTY device or an optional headset is connected to your phone.

Note: When enabled, TTY mode may impair the audio quality of non-TTY devices connected to the headset jack.

Warning: 911 Emergency Calling

Sprint recommends that TTY users make emergency calls by other means, including Telecommunications Relay Services (TRS), analog cellular, and landline communications. Wireless TTY calls to 911 may be corrupted when received by public safety answering points (PSAPs), rendering some communications unintelligible. The problem encountered appears related to software used by PSAPs. This matter has been brought to the attention of the FCC, and the wireless industry and the PSAP community are currently working to resolve this.

Hearing Aid Device Compatibility

Your phone has been tested and rated for hearing aid device compatibility. To use this function effectively, set the hearing aid option to **On**.

1. Press > **Settings** > **Others** > **Accessibility** > **Hearing Aid**.
2. Read the disclaimer and press.
3. Select **On** or **Off**.
 - **On** to use a hearing aid device with your phone.
 - **Off** to use your phone without a hearing aid device.

Sprint Direct Connect

Sprint Direct Connect® on your Sprint phone offers instant, two-way “walkie-talkie-style” communication between you and your family, friends, and co-workers, all at the click of a button. Perfect for get-in get-out conversations such as checking status, getting information, getting directions, or coordinating with others—fast. Call Alert sends an alert to other Direct Connect users to let them know you want to reach them.

[About Sprint Direct Connect](#)

[Before Making Your First Direct Connect Call](#)

[Your Direct Connect Number](#)

[Make and Answer Direct Connect Calls](#)

[Call Alerts](#)

[Group Connect](#)

[Invites](#)

[TeamDC](#)

About Sprint Direct Connect

The following Sprint Direct Connect services are available:

- **Direct Connect®** - Allows two-way radio communication with any other Direct Connect users.
- **Group Connect®** - Create and manage groups in Contacts, “on the fly,” or online to connect instantly with up to 20 other Direct Connect users at the same time. (Currently Sprint phones do not support Group Connect calls with Nextel or PowerSource phones.)*
- **TeamDCSM** - Create a group online that allows nationwide group calling with up to 34 other Direct Connect users (with Sprint phones only). With TeamDC, all members can access the most up-to-date group list on their phone.

**In the future, users will be able to include Direct Connect users with Nextel phones in their Group Connect groups.*

Before Making Your First Direct Connect Call

To enable Direct Connect on your phone, a Sprint Customer Service representative must add Direct Connect service to your account.

Register and Activate Direct Connect

1. Confirm the Direct Connect feature is currently activated on your account.
2. Press > **Settings** > **DC Settings** > **Update DC**.
 - This validates your Direct Connect service with the Sprint Network and then restarts the phone.
3. Verify that Direct Connect is now active:
 - You should not see the  icon at the top of the screen.

Important: When the Direct Connect feature is active, your phone's data services are enabled and the Net Guard feature is disabled (**Settings** > **Others** > **Data Settings** > **Data and Net Guard**).

Your Direct Connect Number

Your Sprint phone allows you two different options for your Direct Connect number:

- Separate numbers (**DC Only**) - Your Direct Connect number is a unique number (not your wireless number). It is made up of three sets of digits separated by asterisks (for example, 444*5555*111).
- A single number (**Mobile+DC**) - Your Direct Connect number is the same as your wireless number (for example, 555-555-1234).

Dial Direct Connect Numbers

Save a Direct Connect Number

Display Your Direct Connect Number

Dial Direct Connect Numbers

- If the person you are calling has a separate number for Direct Connect, make sure you dial any asterisks (*) in the number. If you are saving the number in your Contacts, choose **DC Only** for the phone type.
- If the person you are calling has a single number for both voice calls and for Direct Connect, use that ten-digit phone number to make Direct Connect calls. You do not need to add any asterisks (*) to the number. If you are saving this number in your contacts, choose **Mobile+DC** for the phone type.

Tip: Users with a Nextel phone must always add asterisks (*) between sets of numbers to dial Direct Connect numbers. If you use a single number, make sure to tell your contacts with Nextel phones to dial the ten-digit number using asterisks (*) in place of hyphens (for example, 555*555*1234).

Tip: One way to easily ensure that your contacts have your correct number is to call them so that they can save your number from their Call Log. Ask them for their contact information. Remember you will need all digits of the number to make a successful call. Also, if they have a Nextel phone or a separate number for Direct Connect, you will need to enter asterisks (*) between sets of numbers.

To tell if a number is a valid Direct Connect number:

Check the icon for the highlighted number. If it has a Mobile+DC icon or a DC Only icon (), it is a valid Direct Connect number.

– or –

Highlight a contact and press. “DC capable” will appear below the valid Direct Connect number.

Save a Direct Connect Number

1. Use your keypad to enter a Direct Connect number.
 - The Direct Connect number may be the ten-digit wireless phone number of the contact.
 - or –
 - The Direct Connect number may be a unique number made up of three sets of digits separated by asterisks (for example, 444*5555*111). When saving this type of number, always include the asterisks (*).
2. Press **OPTIONS** (right softkey) > **Save**.
3. Select **New Entry** or **Existing Entry**.
4. Select a number type for the entry:
 - Select **Mobile+DC** if the wireless phone number and the Direct Connect number are the same.
 - Select **DC Only** if the Direct Connect number is different from the wireless phone number. Make sure to include the asterisks (*) between the sections of a DC Only number.

Note: All Direct Connect users with Nextel or PowerSource phones must ALWAYS use an asterisk (*) between sets of digits, even if they are calling another user whose DC number is the same as their wireless phone number. Make sure to include the asterisks when giving your number to a Nextel or PowerSource user (for example, if your number is 555-555-1234, when giving it to a Nextel or PowerSource user, it should be 555*555*1234).

5. Press **DONE** (left softkey) to save the entry.

Tip: You can also save a Direct Connect number from History. From a History listing, press **OPTIONS** (right softkey) > **Save Contact**, and then complete steps 3-5 in [Save a Direct Connect Number](#). To create a new Contacts entry with a Direct Connect Number, see [Create a Personal Entry](#).

Display Your Direct Connect Number

Press  > **Settings** > **Phone Info** > **Phone#/User ID**.

Your Direct Connect number and other information about your phone and account will be displayed.

Make and Answer Direct Connect Calls

You can make a Direct Connect call by entering a Direct Connect number manually or by selecting an entry containing a Direct Connect number in your Contacts or History. For information on saving Direct Connect numbers to Contacts, see [Save a Direct Connect Number](#).

Note: Bluetooth devices cannot be used for Direct Connect calls.

[Make a Direct Connect Call by Entering a Number](#)

[Make a Direct Connect Call From Contacts](#)

[Make a Direct Connect Call From History](#)

[Make a Direct Connect Call Using a Speed Dial Number](#)

[Make a Direct Connect Call With the Phone Closed](#)

[Answer Direct Connect Calls](#)

[End a Direct Connect Call](#)

[Direct Connect Permissions](#)

Make a Direct Connect Call by Entering a Number

1. Use your keypad to enter a Direct Connect number.
 - The Direct Connect number may be the ten-digit wireless phone number of the person you are calling (Mobile+DC).
– or –
If calling a Nextel customer, the Direct Connect number may have three parts with an asterisk between each part (for example: 444*5555*111). When dialing or saving this type of number, always include the asterisks ().
2. Press and release the Direct Connect button (DC button) on the side of your phone.

- Pressing and releasing the DC button “pings” the recipient. The recipient’s phone emits an incoming tone and displays your name or number. If available, he or she can choose to respond and begin the conversation.
 - Alternatively, you can hold the button and speak after you first press and hear the tone. In this case, your voice will broadcast instantly over the recipient’s speaker. Pinging the recipient’s phone by pressing and releasing may avoid unintentional interruptions.
3. After the recipient accepts your call:
 - Wait for “**Open**” to appear onscreen.
 - Press and hold the DC button.
 - Wait for a tone to sound and “**Me**” to appear onscreen before you begin talking.
 4. Release the DC button to listen.
 5. Press  to end the call.

Note: All Direct Connect calls end automatically if there is no activity on the call for several seconds.

Tip: To display your Direct Connect number, press > **Settings** > **Phone Info** > **Phone#/User ID**.

Make a Direct Connect Call From Contacts

1. In standby mode, press **CONTACTS** (right softkey).
2. Highlight an entry and press and release the DC button.
3. Continue the Direct Connect call as described previously.

Make a Direct Connect Call From History

1. Press > **History**.

– or –

From standby mode, press the DC button to display your Direct Connect (including Call Alert) call history only.

- The following icons indicate the types of Direct Connect history entries.

	Incoming	Outgoing	Missed
Direct Connect Call			
Group Connect Call			
TeamDC Call			
Call Alert			
Group Connect Invite			

2. Highlight a Direct Connect entry and press and release the DC button.
3. Continue the Direct Connect call as described previously.

Tip: To redial your most recent Direct Connect call, press and hold the DC button.

Make a Direct Connect Call Using a Speed Dial Number

From standby mode, enter a speed dial number and press the DC button.

To assign a Direct Connect number to a speed dial location, see [Assign Speed Dial Numbers](#).

Make a Direct Connect Call With the Phone Closed



1. Press and hold the external speaker button to unlock the keyguard if the buttons are locked. See [Keyguard](#).
2. Press and hold the external speaker button until you see “DC Speaker mode on” on the external display.
3. Press and release the DC button to display the History on the external display.
4. Use the volume button to scroll through the list and highlight an entry.
5. Press and hold the DC button to begin talking.

Tip: If you see the incoming caller’s information on the external display, but you cannot hear the caller, the audio is being routed to the internal speaker. Press the external speaker button again to route the conversation to the external speaker.

6. Press the call list button to finish the DC call.

Answer Direct Connect Calls

When you receive a Direct Connect call, you hear an incoming tone or the phone vibrates, depending on your settings. You will see the Direct Connect number and the caller's name (if available) on your screen. You may also hear the caller's voice through the speakerphone. Default for Direct Connect calls is speakerphone on. You can turn the speakerphone off and listen to Direct Connect calls through the earpiece as you would a regular call, or you can listen through a headset.

1. Press  or the external speaker button to either enable or disable the Direct Connect speakerphone feature.
 - If you enable the Direct Connect speakerphone () , you will hear the caller's voice through the speakerphone on the front of the phone.
 - If you disable the Direct Connect speakerphone () , you will only hear the caller's voice through the earpiece.
2. Accept the incoming call. If available, the caller's name and Direct Connect number also appear on the display.
3. When the caller has finished speaking, you will hear a tone and see **"Push to Talk"** on the display.
4. Press and hold the DC button and wait for a tone to sound and a message ("**Me**") to appear onscreen. Continue the Direct Connect call as described previously.

Tip: Press  or the call list button to dismiss an incoming Direct Connect call.

End a Direct Connect Call

Do nothing; the call will automatically end after several seconds if neither party presses the DC button.

– or –

Press  or the call list button.

Convert a Direct Connect Call to a Voice Call

1. While on a Direct Connect call, press **OPTIONS** (right softkey) > **Convert Call**.
2. Read the message, and then select a number (if more than one number is available) or select **CONVERT CALL** (left softkey).

Your phone ends the Direct Connect call and dials the selected number.

Tip: **Quieting incoming calls and increasing your privacy.** When you are in an area where incoming Direct Connect calls may disturb others, or if you wish to increase the privacy of your calls, please set your speakerphone to off and your ringer to vibrate.

When the speakerphone is off, Direct Connect calls use the phone's earpiece and microphone, while still utilizing the DC button. You may also use an earbud or other hands-free device for increased convenience.

Direct Connect Permissions

You can control which numbers can reach your phone using Direct Connect.

Set Direct Connect Permissions

1. Press > **Settings** > **DC Settings** > **Permissions**.
2. Select **Accept all DC calls, except those from numbers I block** or **Reject all DC calls, except those from numbers I allow**.
3. If you selected **Accept all DC calls, except those from numbers I block**, select **Block Another #** > **New Number**, **Contacts**, or **Recent DC's**.

– or –

If you selected **Reject all DC calls, except those from numbers I allow**, select **Allow Another #** > **New Number** or **Contacts**.

4. Follow the instructions to add or edit the **BLOCKED DC #S** or the **ALLOWED DC #S** list.
5. The blocked numbers show a red circle with a bar, and the allowed numbers a tick mark in a green circle, both on the phone type icons which appear next to the numbers on the Contacts list, Contacts details, etc.

Tip: You can also allow or block numbers directly from the Contacts list or History. From the Contacts or Recent History list, press **OPTIONS** (right softkey) > **Allow DC Calls** or **Block DC Calls** and follow the onscreen instructions.

Change Permissions

You can change the permissions approach from specifying the blocked numbers to specifying the allowed numbers, or vice versa. All the entries on your existing Blocked DC #s or Allowed DC #s list will be deleted when this switch is made.

1. Press > **Settings** > **DC Settings** > **Permissions**.
2. Press **OPTIONS** (right softkey) > **Change Approach**.
3. Read the message and press **CHANGE** (left softkey) > **Block Another #** or **Allow Another #**.
4. Follow the instructions to add or edit the **Blocked DC #s** or the **Allowed DC #s** list.

Call Alerts

Call Alerts let you notify others that you want to communicate with them using Direct Connect. When a user receives a Call Alert, the phone sounds a tone and displays your name or Direct Connect number.

[Send a Call Alert](#)

[Reply to a Call Alert](#)

Send a Call Alert

Send a notification to start a Direct Connect call.

1. Enter a Direct Connect number or select a number from History or Contacts.

Note: When sending a Call Alert, make sure you select the Direct Connect number for the person you are trying to reach. See [To tell if a number is a valid Direct Connect number](#).

2. Press **MSG/ALERT** (left softkey) > **Call Alert**. (You will see a prompt.)
3. Press and release the DC button. (The receiving phone emits an incoming tone and displays an alert.)

Tip: If you get an error message saying that your contact “is not reachable via Direct Connect” or “this number is not DC capable,” please check to see that you have entered or highlighted a valid Direct Connect number. See [To tell if a number is a valid Direct Connect number](#).

Preset Text Feature With Call Alert

You may attach a brief preset text message to the call alert.

1. Enter a Direct Connect number or select a number from History or contacts.
2. Press **MSG/ALERT** (left softkey) > **Call Alert**. (You will see a prompt.)
3. Press the navigation key left or right to scroll through available messages.
4. Display a message and press and release the DC button.

Note: Preset text messages with Call Alert can only be sent to and from Direct Connect users with Sprint phones. If you send a Call Alert with text to another Direct Connect subscriber without this capability (such as a Nextel user), the user will receive the Call Alert but will not receive the text message.

Note: There is no additional charge to send preset text messages with Call Alerts.

Reply to a Call Alert

Call Alerts continue to repeat for a set amount of time (default is five minutes) or until you return the call or dismiss the alert. You can adjust the default time in the **Settings > DC Settings > Call Alerts > Repetition > Repeat** menu.

1. With the Call Alert displayed, press and hold the DC button to return the call.
2. Continue with the Direct Connect call as previously detailed.

To dismiss a Call Alert:

- Press **IGNORE** (right softkey).

Group Connect

A Group Connect call is a Direct Connect call made to up to 20 Direct Connect users with Sprint phones nationwide at one time. You can make a Group Connect call in several different ways:

- By setting up a group entry in Contact on your phone.
- By using the Sprint Mobile Sync tool available at sprint.com. See [Sprint Mobile Sync](#).
- By selecting or entering multiple numbers for a one-time call.

For information on creating groups and storing them in Contacts, see [Create a Group Entry](#).

Important: When making a Group Connect call or creating a group list for Group Connect calls in Contacts, you must select an entry's DC-capable number. If you select a non-DC-capable number, the name will be added to the list, but Group Connect calls will not go through to that group member.

Make Group Connect Calls

Group Connect Call Information

Make Group Connect Calls

You can make Group Connect calls by selecting saved groups from your Contacts, selecting from group calls saved in History, or by creating groups for one-time use.

Make a Group Connect Call From Contacts

1. In standby mode, press **CONTACTS** (right softkey).
2. Highlight a group and press the DC button to begin the Group Connect call.
3. Continue the Group Connect call in the same manner as a one-to-one Direct Connect call.

Note: Only one person at a time may speak on a Group Connect Call.

4. When you are finished, press  to end the call. (By default, when you end a Group Connect call that you initiated, all other participants are dropped from the call. To change this option, see [Set Group Termination Options](#).)

Note: If you get an error message saying that your contact “is not reachable via Direct Connect” or “this number is not DC capable,” please check to see that you have entered or highlighted a valid Direct Connect number.

Note: Currently Sprint phones do not support Group Connect calls with Nextel and PowerSource phones. This enhancement is planned for future implementation. If your calls are not going through, please check to see whether your contact is using a Sprint phone.

Make a Group Connect Call From History

1. Press > **History**.
2. Highlight a group entry and press the DC button.
3. Continue the Group Connect call as described previously.

Make a Group Connect Call Without Saving

1. In standby mode, press > **Contacts** > **Add New** > **New Group**.
2. Press **START** (left softkey) to add Contacts entries with DC-capable numbers to the group.
 - When adding a contact for the Group Connect call, make sure you highlight the entry’s DC-capable number (**DC Only** or **Mobile+DC**).
3. When you have finished selecting entries, press the DC button.
4. Continue the Group Connect call as described previously.

Join or Rejoin a Group Connect Call

If you are not available at the beginning of a Group Connect call, or if you drop off the call temporarily, you can rejoin an in-progress Group Connect call.

1. Press > **History**.
2. Highlight the call and press the DC button.
3. Continue the Group Connect call as described previously.

Tip: You can also join or rejoin a Group Connect call from your Contacts list if you have stored the group. See [Create a Group Entry](#). Select the group entry and press the DC button.

Note: If the Group Connect call has already ended, pressing the DC button initiates a new Group Connect call.

Note: If you do not want to participate in a Group Connect call, press .

Set Group Termination Options

1. Press > **Settings** > **DC Settings** > **Group Call Options**.
2. Highlight an option and press.
 - **End the call for everyone:** terminates the call session for all connected members.
 - **Allow the call to continue:** keeps the call active even after you hang up. The call will remain active until the last members disconnect.

Group Connect Call Information

During a Group Connect call, the following information may appear on your screen:

- The name of the group.
- The name or Direct Connect number of the person speaking.
- The number of group members who are connected to the call out of the number invited (for example, 4 out of 6).

Invites

You can send an Invite to initiate a Group Connect call. When the group members receive an Invite, their phones sound a tone and display your name (if it is in Contacts).

While on a call, you may also send an invitation message to a specific Contacts entry, or to the group members who have not joined the call yet.

[Send an Invite](#)

[Reply to an Invite](#)

Send an Invite

Send an Invite to start a call

1. Select a group from History or Contacts.
2. Press **MSG/INVITE** (left softkey) > **DC Invite**. (You will see a prompt.)
3. Press and release the DC button.

Send an Invite during a call

To send an Invite to the group members who have not joined the call yet during a Group Connect call:

While on a Group Connect call, press **OPTIONS** (right softkey) > **Send Invites**.

To send an Invite to a personal or group Contacts entry during a Direct Connect or Group Connect call:

1. While on a Direct Connect or Group Connect call, press **OPTIONS** (right softkey) > **Add to Call**.
2. Select an entry from the displayed list or select one of the following options:
 - **Go to Contacts** to select an entry from the available Contacts list.
 - **NEW #** (left softkey) to enter a Direct Connect number and press **NEXT** (left softkey).
3. Press **Send Invites**.

Reply to an Invite

1. With the DC Invite displayed, press and hold the DC button to return the call.
2. Continue with the Direct Connect call as previously detailed.

To dismiss an Invite:

Press **IGNORE** (right softkey).

TeamDC

TeamDC lets Direct Connect users make group calls to up to 34 other users nationwide. With TeamDC, any Direct Connect or Sprint user can create a TeamDC group online, which the system then automatically pushes to all the group members' phones. Once a user creates and distributes a TeamDC group, any member of the group can make a TeamDC call to the entire group. If the user who created the group makes any changes to the group, the system automatically sends updates to the members' phones.

Note: The TeamDC feature supports group calls only with Direct Connect users with Sprint phones. You cannot include users with Nextel phones in TeamDC groups.

[Set Up a TeamDC Group](#)

[Update TeamDC Groups](#)

[Make a TeamDC Call](#)

[Remove Yourself from a TeamDC Group](#)

Set Up a TeamDC Group

Any Direct Connect subscriber on a Sprint phone can create TeamDC groups online. Only the TeamDC group creator or an account administrator may modify a group member list once he or she has created it.

1. Sign on to your account at sprint.com.
2. From your account summary page, click **My Online Tools > Sprint Mobile Sync > My Contacts > Add Group > TeamDC**.
3. Add TeamDC members directly (using Direct Connect numbers) or select individual members or groups from your Contacts list.
4. **(Optional)** Click **Set Talker Priority** to select a Talker Priority for each group member. (Default is **Medium**.)
 - You can assign a priority of **Low**, **Medium**, or **High** to each member.
 - During a TeamDC call, members with a higher Talker Priority can “break in” when members with a lower priority are speaking.

Note: Talker Priority: The optional TeamDC “Talker Priority” feature lets you define a priority level (Low, Medium, or High) for each member of a TeamDC group. When a TeamDC call is active, members with a higher priority may interrupt a member with a lower priority while he or she is speaking. By default, the system all members of a TeamDC group a “Medium” priority level.

5. Click **Save** to save the TeamDC group and distribute it to the other group members.

Update TeamDC Groups

1. In standby mode, press **CONTACTS** (right softkey).
2. Highlight any entry in the list and press **OPTIONS** (right softkey) > **List TeamDC Groups**.
 - Your phone will connect to the network and retrieve a current list of TeamDC Groups for your account.

Make a TeamDC Call

1. In standby mode, press **CONTACTS** (right softkey).
– or –
Press > **History**.
2. Highlight a TeamDC group and press the DC button.

3. Continue the TeamDC call as any other Direct Connect or Group Connect call.
4. When you are finished, press  to end the call. (When you end a TeamDC call that you initiated, all other participants are dropped from the call.)

Note: Group Termination Options: By default, when the originator of a Group Connect or TeamDC call ends the call, the system disconnects all other participants as well. When available, you will be able to select a setting in **Settings > DC Settings > Group Call Options** to allow Group Connect and TeamDC calls you initiate to remain active after you leave the call.

Join or Rejoin a TeamDC Call

If you are not available at the beginning of a call, or if you drop off the call temporarily, you can rejoin the in-progress TeamDC call.

1. Press **> History**.
2. Highlight the TeamDC entry and press the DC button.
3. Continue the TeamDC call as described previously.

Tip: You may also join or rejoin a TeamDC call from your Contacts. Select the TeamDC group and press the DC button.

Note: If the TeamDC call has already ended, pressing the DC button initiates a new TeamDC call.

Remove Yourself from a TeamDC Group

1. In standby mode, press **CONTACTS** (right softkey).
2. Highlight a TeamDC group and press **OPTIONS** (right softkey) **> Remove Me**.
3. Press **REMOVE** (left softkey).

Note: This action also deletes the TeamDC group you belonged to from your Contacts.

Note: TeamDC group membership can either be forced or non-forced. With a forced TeamDC group, an end user on the same account cannot be removed from the group, whereas a user not on the same account can.

TeamDC Call Information

During a TeamDC call, the following information may appear on your screen:

- The name of the group.
- The name or Direct Connect number of the person speaking.
- The number of TeamDC members who are connected to the call out of the number invited (for example, 4 out of 6).

Settings

This section provides an overview of items you can change using your phone's **Settings** menus.

[Display Settings](#)

[Volume Settings](#)

[Ringer Settings](#)

[Messaging Settings](#)

[Phone Setup Options](#)

[Roaming](#)

[Security Settings](#)

Display Settings

Adjusting your phone's display settings not only helps you see what you want, it can also help increase battery life.

[Change the Screen Saver](#)

[Change the Brightness](#)

[Change the Backlight Settings](#)

[Set the Notification Pop-up](#)

[Select a Picture ID](#)

[Power Save Mode](#)

[Change the Clock/Calendar Display](#)

[Set a Custom Greeting](#)

[Change the Phone's Menu Style](#)

[Change the Font Size](#)

[Display Language](#)

Change the Screen Saver

You can set a screen saver to display while in standby mode.

1. Press > **Settings** > **Display** > **Screensaver**.
2. Select a screen saver option by pressing the navigation key up or down, and select a screen saver.

Change the Brightness

You can adjust the brightness on the main screen.

1. Press > **Settings** > **Display** > **Brightness**.
2. Highlight a brightness level and press twice.

Change the Backlight Settings

Select how long the display screen remains backlit after any keypress is made. You can also change the backlight settings for a Java application that is running in the foreground.

To change the main screen backlight setting:

1. Press > **Settings** > **Display** > **Backlight**.
2. Select **Backlight Dim** or **Backlight Off**.
 - If you select **Backlight Dim**, select **Always Bright**, **Always Dim**, or a preset length of time to elapse before the screen backlight dims.
 - If you select **Backlight Off**, select a preset length of time to elapse before the screen and keypad backlights turn off. (When you select **Always Bright** for the **Backlight Dim** setting in step 2, the keypad backlight will turn off after about one minute.)

Note: Long backlight settings reduce the battery's talk and standby times.

To change the Java application backlight setting:

1. Press > **Settings** > **Display** > **Backlight** > **Java Backlight** > **Default** or **Continuous**.

Set the Notification Pop-up

This option allows you to enable or disable notification pop-up when you receive a new notification (except for incoming call and alarm).

1. Press > **Settings** > **Display** > **Notification**.
2. Select **Enable Pop-up** or **Disable Pop-up**.

Tip: If you select **Disable Pop-up**, you will see only a notification icon. (The notification pop-up will not appear while an application is running.)

Select a Picture ID

You can select an image as a picture ID.

1. Press > **Settings** > **Display** > **Picture ID**.
2. Select **Contact**, **Unsaved Numbers**, or **Private / Unknown**.
 - If you select **Contact**, select an entry.
3. Select a picture ID option and press.
4. Select an image and press to assign it.

Power Save Mode

This feature helps conserve your battery power by automatically adjusting the backlight setting of your phone.

1. Press > **Settings** > **Display** > **Power Save Mode**.
2. Select **On**. (Select **Off** to deactivate this feature.)
3. Read the message and press **CONTINUE** (left softkey).

Change the Clock/Calendar Display

Select a clock/calendar display on the main screen in standby mode.

1. Press > **Settings** > **Display** > **Clock/Calendar**.
2. Highlight an option and press twice.

Set a Custom Greeting

You can display your own custom greeting in standby mode.

1. Press > **Settings** > **Display** > **Greeting** > **Custom**.
2. Enter a custom greeting and press.
3. Press **DONE** (left softkey) to save your greeting.

Change the Phone's Menu Style

Choose the layout of your phone's menu.

1. Press to display the main menu.
2. Press **OPTIONS** (right softkey) > **Grid View** or **List View** to change the menu style.

Change the Font Size

Adjust the font size for the main screen. This setting does not affect all screens.

1. Press > **OPTIONS** (right softkey) > **Large Font** or **Normal Font**.

– or –

1. Press > **Settings** > **Others** > **Accessibility** > **Font Size**.
2. Highlight a font size. You can see the current and new font sizes in the display window above the menu.
3. If you are satisfied with the font size, press **SAVE** (left softkey).

Display Language

You can choose to display your phone's onscreen menus in English or in Spanish.

1. Press > **Settings** > **Others** > **Language**.
2. Select **English** or **Español**.

Volume Settings

Adjust your phone's volume settings to suit your needs and your environment.

[Adjust the Phone's Volume Settings](#)

[Silence All](#)

Adjust the Phone's Volume Settings

You can separately adjust the volume of various sounds your phone makes.

1. Press > **Settings** > **Volume**.
2. Select **Incoming Ringer**, **Playback Volume**, **Power Up/Down**, or **Key Beeps**.
 - If you select **Power Up/Down**, select **On** or **Off**.
 - If you select **Key Beeps**, select **Tone Volume** or **Tone Type**.
3. Select a volume level and press.

Tip: You can adjust the ringer volume in standby mode or during an incoming call and the volume during playback by using the volume button.

Silence All

The Silence All option allows you to mute all sounds without turning your phone off.

To activate Silence All:

1. Press and hold the volume button down in standby mode. (The screen will display "Silence All.")

To deactivate Silence All:

Press the volume button up repeatedly to select a volume level.

Ringer Settings

You can assign a ringer or vibration pattern to incoming calls, messages, etc. and also enable audio guidance.

Ringers

Set Up Voice Guide

Select a Vibration Pattern

Ringers

Ringers help you identify incoming calls and messages. You can assign ringers to individual Contacts entries, types of calls, and messages.

Select Ringers for Incoming Calls/Messages

1. Press > **Settings** > **Ringers** > **Incoming Calls** or **Messages**.
2. Select **Contacts**, **Unsaved Numbers**, or **Private / Unknown**.
 - If you select **Contacts**, select **All Contacts**, or select **One Contact** and then select an entry.
3. Select a ringer option by pressing the navigation key up or down, and then select a ringer. (See [Get New Ringers](#) if you selected **Downloaded** > **Get New**.)

Tip: Ringers can be assigned from the **Contacts** menu. See [Assign a Ringer to a Personal Entry](#).

Select Ringers for Direct Connect

1. Press > **Settings** > **Ringers** > **Direct Connect**.
2. Select **Incoming DC Calls** or **Chirp**.
3. Select a ringer option by pressing the navigation key up or down, and then select a ringer.

Select Ringers for Voicemail, Calendar, and Power Up/Down

1. Press > **Settings** > **Ringers**.
2. Select **Voicemail**, **Calendar**, or **Power Up/Down**.
3. Select a ringer option by pressing the navigation key up or down, and then select a ringer.

Get New Ringers

A wide variety of new ringers is available from the Sprint Digital Lounge, and you can access them right from your phone. (Additional charges may apply, but some are free.)

1. Press > **Settings** > **Ringers**.
2. Select a ringer type category (**Incoming Calls**, **Voicemail**, **Messages**, etc.) and any applicable subcategories.
3. Select **Downloaded** > **Get New**. (The Digital Lounge will launch and display the Ringers menu.)
4. Use the navigation key and keypad to search through available ringers. When you find one you want, highlight it and press.
5. To purchase the ringer, use your navigation key to move the cursor over **Buy**. When the cursor changes from an arrow into a hand, press. (The ringer will download automatically.)
6. When the download is finished, select an option to continue:
 - **Listen** to listen to the ringer.
 - **Assign** to assign the ringer to a call or message type or to a specific contact.
 - **Shop** to browse for other items to download.

Set Up Voice Guide

Voice Guide allows you to hear voice prompts and spoken numbers or key names as you press a key, and also to hear menus and options, Contacts names, email addresses, URLs, etc., as you highlight each item onscreen. (The default setting is **Off**.)

1. Press > **Settings** > **Others** > **Accessibility** > **Voice Services** > **Voice Guide**.
2. Select **On** or **Off**.

Note: When the ringer volume is set to **Silence All** or **Vibrate All**, Voice Guide does not work.

Select a Vibration Pattern

You can select vibration patterns for incoming calls, messages, alarms, and scheduled events.

1. Press > **Settings** > **Others** > **Accessibility** > **Vibrate Type**.
2. Select **Incoming Calls**, **Voicemail**, **Messages**, or **Alarm/Calendar**.
3. Highlight a vibration pattern and press.

Messaging Settings

Your phone's advanced messaging capabilities let you send and receive different kinds of messages without placing a voice call.

Messaging settings allow you to create a signature with each sent message and your own preset messages.

[Set Clear Alerts Icon](#)

[Message Alerts](#)

[Set a Callback Number](#)

[Add a Customized Signature](#)

[Manage Preset Messages](#)

[Long Message Reassembly](#)

Set Clear Alerts Icon

Clear Alerts Icon will clear the envelope icon on the display.

1. In standby mode, press **MESSAGING** (left softkey) > **OPTIONS** (right softkey) > **Clear Alerts Icon**.
2. Press **YES** (left softkey).

Message Alerts

You can set how often your phone alerts you when there is a new message notification.

1. In standby mode, press **MESSAGING** (left softkey) > **OPTIONS** (right softkey) > **Repeated Tone** > **Messages**.
2. Select **Single Tone** (once only) or **Repeated Tone** (once every minute).

Set a Callback Number

With this feature, you can specify the callback number your recipients see when you send messages.

1. In standby mode, press **MESSAGING** (left softkey) > **OPTIONS** (right softkey) > **Callback Number**.
2. Select **None**, **My Phone Number**, or **Other**. If you select **Other**, enter a callback number and press.

Add a Customized Signature

Add a customized signature to each message you send.

1. In standby mode, press **MESSAGING** (left softkey) > **OPTIONS** (right softkey) > **Signature**.
2. Select **On**. (If you do not wish to attach a signature to your outgoing messages, select **Off**.)
3. Enter a signature and press.

Manage Preset Messages

Your phone is loaded with 20 preset messages to help make sending messages easier. Customize or delete these messages, such as “Where are you?,” “Let’s get lunch,” and “Meet me at” to suit your needs, or add your own messages to the list.

To edit or delete a preset message:

1. In standby mode, press **MESSAGING** (left softkey) > **OPTIONS** (right softkey) > **Preset Messages**. The list of preset messages will be displayed.
2. To edit or delete a message, highlight it and press **OPTIONS** (right softkey).
3. Select **Edit**, edit the message, and press.

– or –

Select **Delete** > **YES** (left softkey) to delete the message. (You can also reset all messages by selecting **Reset all messages** > **YES** [left softkey].)

To change the language of the preset message:

1. In standby mode, press **MESSAGING** (left softkey) > **OPTIONS** (right softkey) > **Preset Messages**.
2. Press **OPTIONS** (right softkey) > **Select Language**.
3. Select **English** or **Spanish**.

Long Message Reassembly

When you receive a long message, it is divided into up to 15 messages and delivered to your phone. You can choose to combine them to display as one message rather than segmented ones.

1. In standby mode, press **MESSAGING** (left softkey) > **OPTIONS** (right softkey) > **Long Message Re-assembly**.
2. Select **On** or **Off**.

Phone Setup Options

[Navigation Key Shortcuts](#)

Direct Connect Button

Keyguard

Headset Mode

Navigation Key Shortcuts

You can use the navigation keys as shortcuts to access specific menu items directly from standby mode. You can reassign the default shortcuts to the menu items you choose.

1. Press **> Settings > Others > Navigation Keys**.
2. Highlight the navigation key you wish to reassign and press.
3. Using the navigation key or your keypad, highlight a function.
4. Press **ASSIGN** (left softkey) to save. (For options with submenu levels, such as Settings, you can assign submenu options by navigating to the desired option before pressing **ASSIGN**.)

Direct Connect Button

When you are not provisioned for Direct Connect service, you can assign the DC button to other function.

1. Press the DC button in standby mode and then press **CUSTOMIZE** (left softkey).
– or –
Press **> Settings > Others**.
2. Select **DC Button > Do Nothing, Calendar, Bluetooth, or Alarm**.

Keyguard

This feature enables you to lock side buttons while the phone is closed.

1. Press **> Settings > Keyguard**.
2. Select **On**.

Tip: You can deactivate this feature temporarily by pressing and holding the external speaker button while the phone is closed.

Headset Mode

Set up your phone for hands-free use, the type of headset (mono or stereo), and the ringer mode.

To set the audio mode:

Press **> Settings > Others > Headset Mode > Earpiece > Stereo or Mono**.

To set the ringer mode:

Press > **Settings** > **Others** > **Headset Mode** > **Ringer Sound** > **Normal** or **Headset Only**.

To set the headset button mode:

Press > **Settings** > **DC Settings** > **Headset Mode** > **Headset Button** > **Headset button starts Voice calls**. [TALK Key] or **Headset button starts DC calls**. [DC button].

Roaming

Roaming is the ability to make or receive calls and access data services when you're off the Nationwide Sprint Network.

[Roaming on Other Networks](#)

[Roaming Settings](#)

[Roaming Guards](#)

Roaming on Other Networks

When you're roaming on other networks, your call quality and security will be similar to the quality you receive when making calls on the Nationwide Sprint Network. However, you may not be able to access certain features, such as data services, depending on the available network.

Note: If you're on a call when you leave the Nationwide Sprint Network, your call is dropped. If your call is dropped in an area where you think Sprint service is available, turn your phone off and on again to reconnect to the network.

Roaming Icon

Your phone's display screen always lets you know when you're off the Nationwide Sprint Network.

Anytime you are roaming, the phone displays the roaming icon ().

Note: **Sprint Direct Connect** - Direct Connect services are not available while roaming off the Nationwide Sprint Network.

Check for Voicemail Messages While Roaming

When you are roaming off the Nationwide Sprint Network, you may not receive on-phone notification of new voicemail messages. Callers can still leave messages, but you will need to periodically check your voicemail for new messages if you are in a roaming service area for an extended period of time.

1. Dial your ten-digit wireless phone number.
2. When you hear your voicemail greeting, enter .

3. Enter your password at the prompt and follow the voice prompts.

When you return to the Nationwide Sprint Network, voicemail notification will resume as normal.

Roaming Settings

Your phone allows you to control your roaming capabilities. By using the Roaming menu option, you can determine which signals your phone accepts.

To set the roaming mode:

1. Press > **Settings** > **Others** > **Roaming** > **Roaming Mode**.
2. Select an option:
 - **Sprint Only** to access only the Nationwide Sprint Network and prevent roaming on other networks.
 - **Automatic** to seek service on the Nationwide Sprint Network. When Sprint service is unavailable, the phone searches for an alternate service.

When the roaming mode is set to Automatic, you can specify which services are available while roaming.

1. Press > **Settings** > **Others** > **Roaming** > **Roaming Settings**.
2. Highlight each service you want to enable when roaming and press:
 - **Domestic Voice** to access voice service while roaming domestically.
 - **Domestic Data** to access data service while roaming domestically.
 - **International Voice** to access voice service while roaming internationally.
 - **International Data** to access data service while roaming internationally.
3. Press **DONE** (left softkey) > **YES** (left softkey).

Note: Data service is not available without the voice service for both domestic and international settings. Enabling data service automatically enables its voice service and disabling voice service automatically disables its data service.

Roaming Guards



Your phone has two ways of alerting you when you are roaming off the Nationwide Sprint Network: the onscreen roaming icon and Roaming Guards. Roaming Guards make it easy to manage your roaming by requiring an extra step before you can place calls, answer calls, or access data services (such as messaging) while roaming. (This extra step is not required when you are using the Nationwide Sprint Network.) Roaming Guards can be configured separately for domestic and international usage.

To turn Roaming Guards on or off:

1. Press > **Settings** > **Others** > **Roaming** > **Roaming Guards** > **Domestic or International**.
2. Highlight each service you want to enable Roaming Guards for and press.
 - **Voice** to display a prompt that will require you to respond anytime you attempt to access voice service while roaming in the selected region (domestic or international).
 - **Data** to display a prompt that will require you to respond when you attempt to access data service while roaming in the selected region (domestic or international). The prompt will not appear again while you are in the data session you allowed.
 - **Outgoing SMS** to display a prompt that will require you to respond anytime you attempt to send a text message while roaming internationally.
3. Press **DONE** (left softkey).

Note: Roaming Guards are turned on by default on your phone.

To place roaming calls with Roaming Guards on:

1. From standby mode, dial the area code followed by the seven-digit number and press .
2. Read the message and press .

To answer incoming roaming calls with Roaming Guards on:

1. Press .
2. Read the message and press .

To access data services while roaming with Roaming Guards on:

- When a notification appears informing you that data roam charges may apply, press **ROAM** (left softkey) to connect.

To send a text message while roaming with Roaming Guards on:

- When a notification appears informing you that data roam charges may apply, select **Send Now**. You can select **Auto Send Later** to send the message automatically when you return to Sprint coverage, or you can simply save the message by selecting **Save**.

Note: You can turn a Roaming Guard off by selecting **Never Ask** when the message is displayed.

Security Settings

The Security settings menus let you set phone security, lock code, and more.

[Lock Your Phone](#)

[Limit Use](#)

[Delete Phone Content](#)

[Reset Your Phone and Phone Content](#)

[Security Features for Data Services](#)

Lock Your Phone

When your phone is locked, you can only make calls to 911 and Sprint Customer Service.

1. Press > **Settings** > **Lock Phone**.
2. Enter your lock code.
3. Select **Lock Now**.

Tip: The first time you access the Lock Phone menu, you will be advised to change the default lock code by pressing **CHANGE** (left softkey). Enter and re-enter your new lock code to proceed. For details, see [Change the Lock Code](#).

Unlock Your Phone

1. From standby mode, press **UNLOCK** (left softkey).
2. Enter your lock code.

Change the Lock Code

1. Press > **Settings** > **Lock Phone** and enter your lock code.
2. Select **Change Lock Code**.
3. Enter your new lock code.
4. Re-enter your new lock code. (You will be prompted to create a lock code hint to help you remember your new lock code.)
5. If you want to create a lock code hint, select **YES** (left softkey). Enter a hint and press.

– or –

Select **NO** (right softkey) to return to the previous menu.

To edit or delete a lock code hint:

1. Press > **Settings** > **Lock Phone** and enter your lock code.
2. Select **Lock Code Hint**.
3. Edit the hint and press.

– or –

Delete the hint by pressing  and press.

Tip: If you can't recall your lock code, try using the last four digits of your wireless phone number or check your lock code hint. If this doesn't work, call Sprint Customer Service at **1-888-211-4727**.

Limit Use

This feature allows you to limit the use of certain functions on the phone.

Activate the Limit Use Feature

1. Press > **Settings** > **Limit Use** > **On/Off** > **On**.
2. Enter your new code.
3. Re-enter your new code.

The next time you try to access this setting, you will be required to enter your Limit Use code.

Change the Limit Use Code

1. Press > **Settings** > **Limit Use** and enter your limit use code.
2. Select **Change Limit Use Code**.
3. Enter your new code.
4. Re-enter your new code.

Restrict Voice Calls and Messages

1. Press > **Settings** > **Limit Use** and enter your limit use code.
2. Select **Restriction**.
3. Read the message and press **CONTINUE** (left softkey).
4. Select an option:
 - **Voice Calls** to restrict incoming and outgoing voice calls except those placed to 911 or Sprint Customer Service.
 - **Messages** to restrict sending messages except to designated recipients.

5. Select **On/Off** > **On**. Read the message and press **OK** (left softkey).

Note: If you select **On**, you cannot add, edit, and delete any **Contacts** or **Group** entries.

6. Select **Allowed Contacts** > **All Contacts** or **Choose Contacts**.
 - If you select **Choose Contacts**, select **<Add Contact>**, and then choose a member from the list. If you want to remove a member from the list, highlight the member and press **REMOVE** (left softkey).

Restrict Web, Camera, and Location Mode

1. Press > **Settings** > **Limit Use** and enter your limit use code.
2. Select **Restriction**.
3. Read the message and press **CONTINUE** (left softkey).
4. Select an option:
 - **Web** to prevent using the browser.
 - **Camera/Camcorder** to disable the camera and camcorder function.
 - **Force Location On** to prevent turning the Location function off. See [GPS Services](#).
5. Select **On**.

Delete Phone Content

You can quickly and easily delete all the content that you have created or stored in your phone.

1. Press > **Settings** > **Reset/Delete** and enter your lock code.
2. Select **Delete Stuff**.
3. Highlight an option and press.
 - **Messages** to delete all messages.
 - **Call Logs** to delete all call history from the phone.
 - **Browser Cookies and Cache** to delete all Web cookies and all Web cache memory saved in the phone.
 - **Downloaded Content** to delete all data downloaded to your phone.
 - **Contacts** to delete all of your Contacts including speed dial numbers saved in your Contacts.
 - **Voice Memo** to delete all voice data and call memos saved in the phone.

- **My Photos & Videos** to delete all pictures and videos stored in My Photos & Videos.
 - **File Manager(In Phone)** to delete all files saved in File Manager.
 - **All Stuff** to delete all user-added data.
4. Read the message and press **DELETE** (left softkey).

Reset Your Phone and Phone Content

This option lets you clear different types of personal information stored on your phone, reset your phone to factory settings, or both.

1. Press > **Settings** > **Reset/Delete**.
2. Enter your lock code.
3. Highlight an option and press.
 - **Reset Settings** to restore all the factory defaults, including ringer types and display settings. Contacts, History, Calendar, and Messaging are not affected.
 - **Reset Phone** to reset all settings and erase all data on your phone.
4. Read the message and press the left softkey (**RESET SETTINGS** or **RESET PHONE**).

Security Features for Data Services

Enable Data Services

Although your phone's data services are turned off by default, you may enable them at any time.

To enable data services:

1. Press > **Settings** > **Others** > **Data Settings** > **Data** > **On**. (A message is displayed.)
2. Press **YES** (left softkey) to enable data services.

Note: If Direct Connect services are enabled on your phone, this setting is set to **On** automatically and is not displayed.

Disable Data Services

You can disable data services again without turning off your phone; however, you will not have access to all data services, including Web and messaging. Disabling data services will avoid any charges associated with these services. While signed out, you can still place or receive phone calls, check voicemail, and use other voice services.

To disable data services:

1. Press > **Settings** > **Others** > **Data Settings** > **Data** > **Off**.

2. Read the disclaimer and press **DISABLE** (right softkey) to sign out.

Net Guard

When you first connect to the Web, the Net Guard will be displayed to confirm that you want to connect. The Net Guard helps you avoid accidental connections. You can disable the Net Guard in the future by selecting **Auto-Connect** when you see Net Guard displayed.

To change your Net Guard settings:

Press > **Settings** > **Others** > **Data Settings** > **Net Guard**.

- **On** to activate the Net Guard.
- **Off** to deactivate the Net Guard.

Note: When enabled, Net Guard appears only once as long as you have not turned the phone off and on.

If Direct Connect services are enabled on your phone, this setting is set to Off automatically and is not displayed.

History

History keeps track of the calls placed, received, and missed on your phone.

[View History](#)

[History Options](#)

[Make a Call From History](#)

[Save the Information in Your History](#)

[Delete History](#)

View History

History is a list of the last 60 incoming, outgoing, or missed phone calls and Direct Connect calls including Call Alerts. History makes redialing fast and easy. It is continually updated as new numbers or entries are added to the beginning of the list and the oldest entries are removed from the bottom of the list.

Each entry contains the phone number (if available) and Contacts entry name (if the number is in your Contacts). Duplicate calls (calls from the same number) may appear only once on the list.

[The History List](#)

[History Icons](#)

[History Thread](#)

[History Details](#)

The History List

Press > **History**.

Shortcut: From standby mode, press  or the call list button to display your recent calls.

Tip: From standby mode, press the DC button to display your Direct Connect (including Call Alert) call history only.

Note: History records only calls that occur while the phone is turned on. If a call is received while your phone is turned off, it will not be included in History.

History Icons

You can determine if an entry was an incoming, outgoing, or missed call from the icons shown below.

	Incoming	Outgoing	Missed
Phone Call			
Direct Connect Call			
Call Alert			
Group Connect Call			
TeamDC Call			
Group Connect Invite			

History Thread

The History thread screen shows all history for a selected entry. You can also keep track of all the messages you have sent and received for the selected entry.

To display a History thread:

1. Press > **History**.
2. Highlight an entry and press.

History Details

To display History details:

1. Press > **History**.
2. Highlight an entry from the list and press. The History thread is displayed.
3. Highlight an entry and press.

An onscreen menu may also be available according to the type of call. See [History Options](#).

History Options

You may see several menu items on the onscreen menu. Press **OPTIONS** (right softkey) for additional options.

- **Call** to call the selected entry.
- **Send Message** to send a message to the selected entry.
- **New Group** to create a new Group entry. See [Create a Group Entry](#).

- **Contact Details** to display information about the entry if it has already been saved in your Contacts.
- **Save Contact** to save a phone number. See [Save a Number From History](#).
- **Group Details** to display information about the group if it has already been saved in your Contacts.
- **Save Group** to save a Group entry. See [Save a Group From History](#).
- **Delete** to delete the entry.
- **Delete All** to delete all History entries. See [Delete History](#).
- **Prepend** to add numbers to the beginning of the selected number.
- **Allow DC Calls/Block DC Calls** to allow or block a phone number for Direct Connect calls. See [Direct Connect Permissions](#).
- **Call Alert** to send an alert to someone that you'd like to talk with using a Direct Connect call. See [Send a Call Alert](#).
- **Recent DC's** to display the Direct Connect call history.
- **Rename** to change an entry's current name to Caller ID name.
- **Remove Me** to remove yourself from the TeamDC group. See [Remove Yourself from a TeamDC Group](#).

Make a Call From History

1. Press > **History**.
2. Highlight an entry and press .

Note: You cannot make calls from History to entries identified as **No Caller ID**, **Private (Restricted ID)**, or **Unavailable ID**.

Save the Information in Your History

You can store the information which appears in your History into your Contacts.

[Save a Number From History](#)

[Save a Group From History](#)

[Make a New Group Entry From History](#)

Save a Number From History

1. Press > **History**.
2. Highlight an entry and press **OPTIONS** (right softkey) > **Save Contact**.
3. Select **New Entry** or **Existing Entry**.
4. If **New Entry** was selected, select a number type, and then enter the new entry name.

– or –

If **Existing Entry** was selected, select an existing entry to which you want to save the number, and then highlight a number type and press.

5. Press **DONE** (left softkey) to save the entry.

Save a Group From History

1. Press > **History**.
2. Highlight a group entry and press **OPTIONS** (right softkey) > **Save Group**.
3. Enter a group name and use the keypad to complete or edit the group entry.
4. Press **SAVE** (left softkey).

Make a New Group Entry From History

1. Press > **History** > **OPTIONS** (right softkey) > **New Group**.
2. Read the message and press **START** (left softkey).
3. Highlight an entry you want to add to a group and press. A check mark will appear in the box next to the selected entry.

Tip: Press **OPTIONS** (right softkey) > **Enter New Address** or **Contacts** to enter a new phone number or address or to select an entry from your history.

Note: Each group entry can contain up to 40 members for sending messages, or up to 20 members for making Direct Connect group calls.

4. When you have selected all the entries you want to add, press **CONTINUE** (left softkey).
5. Enter a group name and press > **SAVE** (left softkey).

Delete History

You can delete individual or all entries in your History.

1. Press > **History**.
2. Highlight an entry you wish to delete and press **OPTIONS** (right softkey) > **Delete**.

3. Select **Delete All** to delete all entries.
4. If you are certain you want to delete one or all entries from History, press **DELETE** (left softkey).

Contacts

Your phone's Contacts help you stay in touch with family, friends, and colleagues by keeping track of all their contact information. This section explains how to use your phone's Contacts.

[About Contacts](#)

[View Contacts](#)

[Create a New Contacts Entry](#)

[Edit a Contacts Entry](#)

[Find Contacts Entries](#)

[Use Contacts Information in Other Applications](#)

[Assign Speed Dial Numbers](#)

[Secret Contacts Entries](#)

[Dial Sprint Services](#)

[Sprint Mobile Sync](#)

About Contacts

There are three types of Contacts entries:

- **Personal Contacts Entry** – An entry for an individual. Your phone can store up to 600 personal Contacts entries. Each entry can contain up to seven phone numbers (including direct Connect numbers), and three email addresses, IM addresses, and Web addresses.
- **Group Connect Entry** – An entry that contains more than one personal Contacts entry. Your phone can store up to 25 group connect entries. Each group entry can contain up to 40 members for sending messages, or up to 20 members for making Direct Connect group calls.
- **TeamDC Entry** – An entry created and managed online, which contains up to 35 personal Contacts entries including the creator. Once created, the TeamDC entry is distributed to the members via server and only the creator or an account administrator may modify the entry. Your phone can store up to 40 TeamDC entries.

View Contacts

Access your Contacts entries currently stored in your phone.

[The Contacts List](#)

[Contacts Details](#)

[View History From Contacts](#)

The Contacts List

1. In standby mode, press **CONTACTS** (right softkey). You will see the Contacts list.
2. Highlight a personal entry to show the entry's main phone number, or highlight a group entry to show how many members it has.

Contacts Details

1. In standby mode, press **CONTACTS** (right softkey).
2. Highlight an entry and press **ENTER** to show the details.

Tip: Highlight any data field and press **ENTER** on the details screen. Menu options for that field will appear, if available.

View History From Contacts

You can view the history of a selected Contacts entry from the Contacts list.

1. In standby mode, press **CONTACTS** (right softkey).
2. Highlight an entry and press **OPTIONS** (right softkey) > **Contact History**.

Create a New Contacts Entry

Add new Contacts entries to your Contacts to build it up.

Note: Your Contacts also stores TeamDC entries, but a user must create TeamDC entries online. See [Set Up a TeamDC Group](#).

[Create a Personal Entry](#)

[Create a Group Entry](#)

[Save a Number Using the Phone Keypad](#)

Create a Personal Entry

1. In standby mode, press **CONTACTS** (right softkey) > **Add New...** > **New Contact**.
2. Enter a name for the new entry and press the navigation key down.
3. Enter the phone number or Direct Connect number and press. See [Your Direct Connect Number](#) for information on Direct Connect numbers.

4. Highlight a number type for the entry (**Mobile, Mobile+DC, Home, Work, DC Only, Pager, Fax, or Other**) and press.
5. Press **DONE** (left softkey).

After you have saved the number, the new Contacts entry is displayed.

Tip: ICE - In Case of Emergency

To make it easier for emergency personnel to identify important contacts, you can list your local emergency contacts under “ICE” in your phone’s Contacts list. For example, if your mother is your primary emergency contact, list her as “ICE-Mom” in your Contacts list. To list more than one emergency contact, use “ICE1-___,” “ICE2-___,” etc.

Create a Group Entry

You can create a group by assigning personal Contacts entries as members and then naming the new group. Each group entry can contain up to 40 members for sending messages, or up to 20 members for making Direct Connect group calls. Currently, Sprint phones do not support Group Connect calls with Nextel or PowerSource phones. When creating a group entry, please make sure to include only users with Sprint phones.

1. In standby mode, press **CONTACTS** (right softkey) > **Add New... > New Group**.
2. Read the message and press **START** (left softkey).
3. Highlight an entry you want to add to a group and press. A check mark will appear in the box next to the selected entry.

Tip: Press **OPTIONS** (right softkey) > **Enter New Address** or **Recent History** to enter a new phone number or address or to select an entry from your history.

Note: When creating a group for Direct Connect group calls, you must select an entry’s DC-capable number. If you select a non-DC-capable number, the name will be added to the list, but Group Connect calls will not go through to that group member.

4. When you have selected all the entries you want to add, press **CONTINUE** (left softkey).
5. Enter a group name and press > **SAVE** (left softkey).

Save a Number Using the Phone Keypad

You can save a phone number to Contacts directly from the phone keypad.

1. From standby mode, enter a phone number or Direct Connect number.
2. Press **OPTIONS** (right softkey) > **Save**. (If this is the first time you are saving an entry to Contacts, skip to step 4.)
3. Select **New Entry** or **Existing Entry**.
4. If you chose **New Entry**, select a number type, and then enter the new entry name.

– or –

If you chose **Existing Entry**, select an entry to which you want to save the number, and then highlight a number type and press.

5. Press **DONE** (left softkey) to save the entry.

Edit a Contacts Entry

Once you've added a Contacts entry, you can add or edit the information in the entry.

[Edit a Contacts Entry](#)

[Delete a Contacts Entry](#)

[Add a Number to a Personal Entry](#)

[Assign a Ringer to a Personal Entry](#)

[Assign a Picture to a Personal Entry](#)

[Add Members to a Group Entry](#)

[Remove Members From a Group Entry](#)

Edit a Contacts Entry

1. In standby mode, press **CONTACTS** (right softkey).
2. Highlight the entry you want to edit and press **OPTIONS** (right softkey) > **Edit Contact** or **Edit Group**.
3. Highlight the information you wish to edit.
4. Add or edit the information and press.
5. Press **DONE** (left softkey) or **SAVE** (left softkey) to save your changes.

Delete a Contacts Entry

1. In standby mode, press **CONTACTS** (right softkey).
2. Highlight an entry or a group you want to delete.
3. Press **OPTIONS** (right softkey) > **Delete Contact** or **Delete Group**.
4. Press **DELETE** (left softkey).

Add a Number to a Personal Entry

1. In standby mode, press **CONTACTS** (right softkey).

2. Highlight the entry you want to add a number to and press **OPTIONS** (right softkey) > **Edit Contact** > **<Add Number>**.
3. Enter the new number and press.
4. Highlight a label for the number and press.
5. Press **DONE** (left softkey) to save the new number.

Assign a Ringer to a Personal Entry

Assign a ringer to a Contacts entry so that you can identify the caller by the ringer. See [Ringers](#).

1. In standby mode, press **CONTACTS** (right softkey).
2. Highlight an entry and press.
3. Select **Set Ringers** > **Incoming Calls** or **Message**.
4. Select **Change**.
5. Highlight a ringer category, such as **Default Ringer**, **My Videos**, **Downloaded**, **Preloaded Ringers**, or **No Ringer** and then press.
6. Highlight a ringer and press.

Tip: If you select **Downloaded** > **Get New** in step 5, you can purchase and download new ringers right from your phone. For details, see [Get New Ringers and Download Games, Ringers, and More](#).

Assign a Picture to a Personal Entry

Assign a picture to display each time a certain contact calls you.

1. In standby mode, press **CONTACTS** (right softkey).
2. Highlight an entry and press.
3. Highlight and press.
4. Select **Choose Photo**.
5. Select a photo category and press.
6. Select an image and press to assign it.

Add Members to a Group Entry

You can add a group member to an existing Group.

1. In standby mode, press **CONTACTS** (right softkey).

2. Highlight the group you want to add members to and press **OPTIONS** (right softkey) > **Edit Group** > **Add More**.
3. Read the message and press **START** (left softkey).
4. Highlight an entry you want to add and press.
 - If the entry has more than one number, select a number or numbers. Each selected number will be added as a separate entry to the group.
5. Repeat step 4 to add additional members.
6. Press **CONTINUE** (left softkey) > **SAVE** (left softkey).

Remove Members From a Group Entry

1. In standby mode, press **CONTACTS** (right softkey).
2. Highlight the group you want to remove members from and press **OPTIONS** (right softkey) > **Edit Group**.
3. Highlight a member and press **OPTIONS** (right softkey) > **Remove from Group** > **YES** (left softkey).
4. Repeat step 3 to remove additional members.
5. Press **SAVE** (left softkey).

Find Contacts Entries

You can easily search the information stored in your Contacts.

[Find an Entry From Contacts](#)

[Find an Entry Using the Phone Keypad](#)

Find an Entry From Contacts

1. In standby mode, press **CONTACTS** (right softkey).
2. Scroll through all the entries.

– or –

Enter the first few letters of any part of an entry's name. Contacts with matching letters are listed. (The more letters you enter, the more your search narrows.)
3. Highlight an entry and press  to dial the number displayed. (Press the navigation key left or right to display other listed numbers.)

– or –

Highlight an entry and press **OK** to display the details.

Find an Entry Using the Phone Keypad

You can search Contacts entries for the numbers that contain a specific string of numbers.

1. Enter four or more digits of the number in standby mode. (The more numbers you enter, the more specific the search becomes.)
2. All Contacts entries matching the entered numbers will be displayed.
3. Highlight an entry and press **OK** to dial the number.

– or –

Highlight an entry and press **OK** to display further options available.

Use Contacts Information in Other Applications

You can use saved Contacts information in other applications.

To copy information into a message:

1. In standby mode, press **CONTACTS** (right softkey).
2. Highlight an entry and press **OK**.
3. Highlight the information you want to copy, such as phone numbers, email addresses, URLs, or street addresses, and press **OK**.
4. Select **Share > Message**.

After you select one or more recipients, the text entry screen for the type of message specified will open, and the selected text will appear in the body of the message.

Note: For more information about messaging, see [Messaging](#).

To copy address information into a Sprint Navigation application:

1. In standby mode, press **CONTACTS** (right softkey).
2. Highlight an entry and press **OK**.
3. Highlight an address and press **OK**.
4. Highlight an option and press **OK**.
 - **Navigate** to get directions to the street address using Sprint Navigation.
 - **Map** to display the address on a map.

Note: For more information about your phone's navigation features, see [GPS Navigation](#).

Assign Speed Dial Numbers

Your phone can store up to 98 phone numbers or Direct Connect numbers in speed dial locations. (See [Call Using a Speed Dial Number](#) and [Make a Direct Connect Call Using a Speed Dial Number](#).)

1. Add a number to a new or to an existing Contacts entry. See [Add a Number to a Personal Entry](#), if the number is not in your Contacts.

– or –

In standby mode, press **CONTACTS** (right softkey), highlight an entry and press.

2. Highlight the number and press **OPTIONS** (right softkey) > **Set Speed Dial**.
3. Highlight an available speed dial location and press.
4. Press  to return to the Contacts menu.

Tip: To replace a current assignment, select a location and press **REPLACE** (left softkey).

To check speed dial assignments:

1. In standby mode, press **CONTACTS** (right softkey).
2. Press **OPTIONS** (right softkey) > **Settings** > **Speed Numbers**.

Secret Contacts Entries

When you make an entry secret and hide it, that entry is not displayed in your Contacts. In History, a telephone number is displayed but the Contacts entry's name is not. You cannot make TeamDC entries secret.

To set or unset an entry secret:

1. In standby mode, press **CONTACTS** (right softkey).
2. Highlight an entry and press **OPTIONS** (right softkey) > **Set as Secret** or **Set as Not Secret**.

To hide or show secret entries:

1. In standby mode, press **CONTACTS** (right softkey).
2. Press **OPTIONS** (right softkey) > **Settings** > **Hide Secret** or **Show Secret**.
3. Enter the four-digit lock code.

Tip: If you can't recall your lock code, try using the last four digits of your wireless phone number. If this doesn't work, call Sprint Customer Service at **1-888-211-4727**.

Dial Sprint Services

Your Contacts list is preprogrammed with contact numbers for various Sprint services.

To dial a service from your Contacts:

1. In standby mode, press **CONTACTS** (right softkey).
2. Press **OPTIONS** (right softkey) > **Settings** > **Services**.
3. Select **Hear Minutes** (Account Info.), **Customer Solution** (Service), **Directory Assistance** (Sprint 411), **Sprint Operator**, **Hear Balance**, **Voicemail**, **Community Information**, **Non Emergency Services**, **Traffic Information**, **Carrier Repair Service**, **TRS Relay for TTY**, **Call Before You Dig**, or **Emergency**.
4. Press.

To dial a service from standby mode using your keypad:

Dial the appropriate service number:

- Account Info. - *336 436 7663
- Customer Service - *336 236
- Sprint 411 - 411 111 111
- Sprint Operator - 011

Sprint Mobile Sync

You can add and edit all your contacts and groups, including TeamDC groups, online using the Sprint Mobile Sync service. With Sprint Mobile Sync you can:

- **Add and edit contacts and groups.** Use your computer to easily add, edit, and manage contacts and groups, and set up and manage TeamDC groups.
- **Synchronize and back up your contacts.** Save all the contacts information from your phone in a secure location, and automatically synchronize new information from the computer to the phone and from the phone to the computer.
- **Transfer contacts to a new phone.** When you activate a new phone, Sprint Mobile Sync sends your existing contact information to the phone upon activation.
- **Erase contact information from a lost phone.** If your phone is lost or stolen, Sprint Mobile Sync can remotely remove all the contact information. You can then send the information to your replacement phone.

- **Import and export contacts with online address books.** Import or export contact information from or to Outlook, or other compatible databases.

Prepare Your Phone for Sprint Mobile Sync Service

Once your phone makes itself available to the Mobile Sync service, it will display a message on the screen and prompt you to activate the service. Follow the onscreen instructions to activate the service. (You will see a message when the process is complete.)

Activate Sprint Mobile Sync

1. Press > **Tools** > **Mobile Sync**.
2. Follow the onscreen instructions to complete activation.

Access Sprint Mobile Sync Online

1. Sign on to your **MySprint** page at sprint.com.
2. Click **MyOnline Tools** > **Sprint Mobile Sync** > **My Contacts**.
3. Follow the onscreen instructions to add, edit, and manage all your contact information

Messaging

Send your messages to your family and friends with Text Messaging (SMS) and Multimedia Messaging (MMS). You can also set up an Email account on your phone.

Text Messaging and Multimedia Messaging

Email

Text Messaging and Multimedia Messaging

With messaging, you can send and receive messages between your phone and another messaging-ready phone. When you receive a new message, it will automatically display on your phone's screen.

In addition, messaging includes a variety of preset messages, such as "The meeting has been cancelled," that make composing messages fast and easy. Use your phone to customize your own preset messages (up to 50 characters).

There are two types of messaging, Text Messaging (SMS) and Multimedia Messaging (MMS).

Text messages can be composed of up to six segments of 160 (140 in Spanish) characters each, for a total of 960 (840 in Spanish) characters per text message. The current segment and total segment count is displayed at the top of each segment. For example, (5/6) at the top of a segment would indicate you are viewing segment five of a six-segment message.

Multimedia messages consist of both text and multimedia files, such as pictures, videos, or voice recordings. Outgoing multimedia messages can be up to 1 MB with up to 1000 text characters.

Compose Messages

Access Messages

Threaded Messaging

Compose Messages

1. Press > **Messaging**.

Shortcut: Press **MESSAGING** (left softkey) in standby mode.

2. Press **Send Message**.
3. Select a recipient from the list or from the following options:
 - **Go to Contacts** to select a recipient from your Contacts. (Qualifying Contacts entries must contain a phone number or an email address.)

- **MULTIPLE** (left softkey) to select multiple recipients. Press **CONTINUE** (left softkey) when you have finished selecting and entering recipients. (You may include up to 40 recipients per message.)
 - **NEW ADDRESS** (right softkey) to enter a recipient's phone number or email address directly. Press **CONTINUE** (left softkey) to proceed.
4. Compose a message.
 - Press **OPTIONS** (right softkey) to select additional options.
 5. Select **<Add Attachment>** and select a category of files you would like to attach (**Picture, Video, Voice, Audio, or File Manager**).
 6. Select a location where your file is stored. (You can also choose to take a new picture or video, or to record a new voice or audio clip.)
 7. Select files you would like to attach.
 8. Review your message and press **SEND** (left softkey).

Access Messages

To read a message:

- When you receive a message, your phone will display a notification message. Use your navigation key or select **View**.

To reply to a message:

1. While the message is displayed, press **REPLY** (left softkey).
 - Select **Reply to Sender**, or select **Reply All** if you are replying to an MMS message with multiple recipients.
2. Compose a reply and press **SEND** (left softkey).

Threaded Messaging

Threaded messaging lets you follow a chain of messages to and from a particular contact.

To display the thread list:

- In standby mode, press **MESSAGING** (left softkey) > **Messages**.

You will see a thread list. Each thread has an entry's name (if saved in Contacts), a phone number, or an email address. You will also see the number of unread messages, if any, for each thread.

View Messages

Highlight a thread and press  to display the messages sent to and received from a particular contact, in reverse chronological order. Failed, pending, and draft messages are also listed.

Highlight a message to see details for that message.

- **Me** - Message you sent.
- **Me (Failed)** - Message you did not send successfully.
- **Me (Pending)** - Message you have not sent yet because your phone has no network connection. The message will be sent automatically when your phone reconnects to the network.
- **Me (Draft)** - Message you saved as a draft. Only one draft can be saved in each thread, and that draft appears at the top of the thread.



Message Details

Highlight a message and press  to display the message details and view the entire message.

You can select certain information from a message and automatically save it or use it in a related application. See [Simple Data Exchange](#).

Threaded Messaging Options

When you are viewing a messaging thread list, a message thread, or a message details screen, you can choose from among the following options. (Options will vary according to screen.)

- Press  or  to make a call.
- Press **SEND MESSAGE** (left softkey) to send a message to the entry.
- Press **REPLY** (left softkey) to reply to a message.
- Press **SEND** (left softkey) to send a draft message.
- Press **RESEND** (left softkey) to resend a failed message.
- Select a message, press **OPTIONS** (right softkey) and select an option:
 - **Forward** to forward the selected message.
 - **Call Alert** to send a Call Alert.
 - **Send Invite** to send an Invite.
 - **Lock** to lock the selected message.

- **Unlock** to unlock the selected message.
- **Unlock All** to unlock all messages.

Note: Messages are automatically deleted starting with the oldest. To save messages, lock them.

- **Delete** to delete the selected message.
- **Delete All** to delete all messages.
- **Call** to dial the phone number appearing in the selected message.
- **Launch** to open the URL appearing in the selected message.
- **Save Number** to save the phone number appearing in the selected message.
- **Save Email** to save the email address appearing in the selected message.
- **Manage Text Blocking** to block text messages from specific phone numbers or email addresses.
- **Settings** to display the Messaging Settings menu.
- **Combine/Uncombine** to display segmented messages as one message or vice versa.

Email

Messaging allows you to stay connected 24 hours a day anywhere on the Nationwide Sprint Network.

Get Started With Email

1. Press > **Web**.
2. From the SprintWebSM home page, select **Messaging > Email**.
3. Select **Yahoo! Mail**, **AOL & AIM Mail**, or **MSN Hotmail**.
4. Use your keypad to enter the required sign-in information for the selected provider, such as user name, email address, or password, and select **Sign In**. (Your mailbox for the selected provider will be displayed.)
5. Follow the onscreen instructions to read, reply to, compose, and send messages and manage your email account.

Calendar & Tools

Learn how to use many of your phone's productivity-enhancing features.

[Calendar](#)

[Alarm](#)

[Bluetooth](#)

[Voice Services](#)

[Calculator](#)

[World Clock](#)

[Countdown Timer](#)

[Stopwatch](#)

Calendar

Use Calendar to create and manage events, meeting, and appointments. Your Calendar helps organize your time and reminds you of important events.

[Add an Event to the Calendar](#)

[Add a To Do List Item to the Calendar](#)

[Calendar Alerts](#)

[View Events](#)

[Delete Events](#)

Add an Event to the Calendar

Your Calendar helps organize your time and reminds you of up to 100 important events.

1. Press > **Tools** > **Calendar**.
2. Highlight a day to which you would like to add an event and press **OPTIONS** (right softkey) > **Add Schedule**.
3. Enter a description and press.
4. Select a category for the event (Appointment, Meeting, etc.) by highlighting the category field and pressing.

5. Select a priority for the event by highlighting the priority field and pressing.
6. Select a start and end time for the event by highlighting the start and end time fields and pressing.
7. Highlight the location field and enter a location for the event and press.
8. Select a ringer type for the alarm by highlighting the ringer field and pressing.
 - To download ringers, select **Downloaded** > **Get New**.
9. Select an alarm time by highlighting the alarm time field and pressing.
10. Select a repeat status for the alarm by highlighting the repeat field and pressing.
 - If you chose **Specific Period**, set a start and end date for the repeat status and press **OK** (left softkey).
 - If you chose **Weekly**, select the check box for each day of week you wish to set and press **DONE** (left softkey).
11. Press **SAVE** (left softkey).

Tip: To change the calendar display views, press the left softkey (**MONTH** or **WEEK**) repeatedly to toggle between monthly and weekly views.

Tip: On the weekly view, press the navigation key up or down to display the previous week or the next week, respectively.

Tip: Press **OPTIONS** (right softkey) > **Settings** > **Holiday/Weekday** to enter holidays and weekdays.

Add a To Do List Item to the Calendar

Your phone can store and manage up to 40 To Do list items.

1. Press > **Tools** > **Calendar**.
2. Highlight a day to which you would like to add a To Do list item and press **OPTIONS** (right softkey).
3. Press the navigation key right and select **Add To Do**.
4. Enter a description and press.
5. Select a category for the item by highlighting the category field and pressing.
6. Select a priority for the item by highlighting the priority field and pressing.
7. Select a time and date for the item by highlighting the time and date field and pressing.

8. Select a status for the item by highlighting the status field and pressing. When you add an item, set it to **Needs Action**.
9. Press **SAVE** (left softkey).

Calendar Alerts

If you have an event on the Calendar, your phone alerts you by a ringing or vibrating alarm and displays a summary of the event.

To respond to the alarm, select an available onscreen menu or press the appropriate softkey:

- Press **SNOOZE** (left softkey) or **Snooze** to stop the alarm and start snooze mode (if applicable).
- Press **DISMISS** (right softkey) to clear the alarm (if applicable).
- Select **View** to display the event detail screen.

Tip: To change the alarm settings, press **OPTIONS** (right softkey) > **Settings** > **Alarm** to set the snooze options.

View Events

Tip: Days with scheduled events are indicated by small colored rectangles just below the date. A rectangle's color depends on the repeat status for an event.

1. Press > **Tools** > **Calendar**.
2. Highlight the day for which you would like to view events and press. The day's event list is displayed.

– or –

Press **OPTIONS** (right softkey) > **Schedule List** or **To Do List**.
3. Highlight an event and press. The event's details are displayed. You can edit the event on this screen.

Delete Events

1. Press > **Tools** > **Calendar**.
2. Highlight the day from which you would like to delete an event and press.

– or –

Press **OPTIONS** (right softkey) > **Schedule List** or **To Do List**.
3. Highlight an event and press **OPTIONS** (right softkey) > **Delete**.
4. Highlight an option and press.

- **This** to delete the highlighted event.
- **Select** to delete multiple events.
- **All on This List** to delete all events on the list.
- **All Completed Events** to delete completed To Do List items.

5. Press **YES** (left softkey).

To delete old events or all events:

Press > **Tools** > **Calendar** > **OPTIONS** (right softkey) > **Delete Memory** > **Delete Old** (or **Delete All**) > **YES** (left softkey).

Alarm

Your phone comes with a built-in alarm that has multiple alarm capabilities.

1. Press > **Tools** > **Alarm**.
2. Highlight an alarm number and press.
3. Turn the alarm on or off by highlighting the alarm field and pressing.
 - Highlight **On** or **Off** and press.
4. Enter a description for the alarm by highlighting the description field and pressing.
5. Select a time for the alarm by highlighting the time field and pressing.
6. Select a repeat status for the alarm by highlighting the repeat field and pressing.
7. Select a ringer option for the alarm by highlighting the ringer field and pressing.
8. Select a volume level for the alarm by highlighting the volume field and pressing.
9. Select a ringer length for the alarm by highlighting the ringer length field and pressing.
10. Select a snooze interval for the alarm by highlighting the snooze interval field and pressing.
11. Select the number of times the snooze should repeat by highlighting the snooze time field and pressing.
12. Press **SAVE** (left softkey).

Tip: Press **ON** or **OFF** (left softkey) to toggle the alarm on and off.

Bluetooth

Bluetooth® is a short-range communications technology that allows you to connect wirelessly to a number of Bluetooth devices, such as headsets and hands-free car kits, and Bluetooth-enabled handhelds, computers, printers, and wireless phones. The Bluetooth communication range is usually approximately 30 feet.

[Turn Bluetooth On and Off](#)

[Make Your Phone Discoverable](#)

[Bluetooth Menu](#)

[Pair Bluetooth Devices](#)

[View the Trusted Devices List](#)

[Send Items via Bluetooth](#)

Turn Bluetooth On and Off

By default, your phone's Bluetooth feature is turned off. Turning Bluetooth on enables your phone's Bluetooth functions.

1. Press **> Tools > Bluetooth > On/Off**.
2. Press **ON** (left softkey) to enable Bluetooth. Press **OFF** (left softkey) to disable Bluetooth.

Make Your Phone Discoverable

To make your phone discoverable (allowing other Bluetooth devices to detect it), you must set your phone's visibility to other than **Hidden**.

1. Press **> Tools > Bluetooth > Visibility**.
2. Select **Visible for 3 min** or **Always visible**. If you select **Always visible**, your phone will be discoverable by all in-range Bluetooth devices until you change the setting. If you select **Visible for 3 min**, your phone will return to hidden mode after three minutes.

Bluetooth Status Indicators

The following icons show your Bluetooth connection status at a glance:

Bluetooth feature is on.

Your phone is visible to other Bluetooth devices.

Your phone is connected to a Bluetooth device.

Your phone is connected to or communicating with a Bluetooth device via Hands-free Profile (HFP).

Your phone is connected to or communicating with a Bluetooth device via Advanced Audio Distribution Profile (A2DP).

The above icons will blink while your phone is communicating with a Bluetooth device.

Bluetooth Menu

The **Bluetooth** menu allows you to set up many of the characteristics of your phone's Bluetooth service, including:

- Setting your phone's visibility (or "discoverability") for other Bluetooth devices.
- Adding a new Bluetooth device to your phone.
- Displaying your Bluetooth trusted devices list.
- Displaying your phone's Bluetooth information.

To access the Bluetooth menu:

Press > **Tools** > **Bluetooth** to select from following options:

- Select **On/Off** to enable or disable Bluetooth.
- Select **Visibility** > **Hidden**, **Visible for 3 min**, or **Always visible** to set your Bluetooth visibility.
- Select **Add New** to add a new Bluetooth device.
- Select **Trusted Devices** to display a list of trusted Bluetooth devices.
- Select **My Bluetooth Info** to display your phone's Bluetooth name, address, class, and supported profiles.

Pair Bluetooth Devices

The Bluetooth pairing process allows you to establish trusted connections between your phone and another Bluetooth device. When devices are paired, a passkey (PIN) is shared between devices, allowing for fast, secure connections while bypassing the discovery and authentication process.

1. Press > **Tools** > **Bluetooth** > **Add New**.
2. Select the device you wish to pair with and press.
3. Enter the passkey and press.
4. (Optional) Edit the device name and press **SAVE** (left softkey).

Note: Due to different specifications and features of other Bluetooth compatible devices, display and operations may be different, and functions such as transfer or exchange may not be possible with all Bluetooth compatible devices.

View the Trusted Devices List

This list displays a list of devices which are paired with your device and set as trusted devices.

Press > **Tools** > **Bluetooth** > **Trusted Devices**.

Trusted Devices List Menu

Once you have created trusted devices, several options are available from the Trusted Devices list.

Left Softkey Menus

1. Press > **Tools** > **Bluetooth** > **Trusted Devices**.
2. Highlight a device and press the available left softkey options:
 - **CONNECT...** to connect to the selected Bluetooth device, if not connected (for headsets, hands-free and other devices, excluding computers, PDAs, phones, or printers).
 - **TRANSFER...** to send data saved on your phone to the selected Bluetooth device (for computers, PDAs, or phones). See [Send Items via Bluetooth](#).
 - **PRINT...** to print pictures using the selected Bluetooth-enabled printer.

Options Menu

1. Press > **Tools** > **Bluetooth** > **Trusted Devices**.
2. Highlight a device and press **OPTIONS** (right softkey) to display the following options:
 - **Add New** to add a new Bluetooth device.
 - **Delete** to delete the selected device from the list.
 - **Delete All** to delete all devices from the list.
 - **Auto-Accept** to configure your phone's accessibility to other Bluetooth devices.
 - **View/Edit Info** to view or edit the information of the selected device.
 - **Help** to display the Trusted Devices list help.

Send Items via Bluetooth

Depending on your paired devices' settings and capabilities, you may be able to send pictures or videos, Contacts information, or other items using a Bluetooth connection.

1. Press > **Tools** > **Bluetooth** > **Trusted Devices**.
2. Select the device from the Trusted Devices list and press **TRANSFER...** (left softkey).
3. Select an item (**Contacts**, **Photos / Videos**, **Music**, **Files**, or **Calendar Events**) and press.
4. Follow the onscreen instructions to select items to send.
5. Read the message and press **SEND** (left softkey).

Voice Services

Your phone's voice services let you place calls using your voice, store voice reminders, and record memos right on your phone. This section includes easy-to-follow instructions for using voice-activated features and managing voice memos.

Automatic Speech Recognition (ASR)

Manage Voice Memos

Automatic Speech Recognition (ASR)

You can use your phone's built-in automatic speech recognition (ASR) software to dial a phone number or to launch phone functions. All you have to do is to talk into the phone, and ASR will recognize your voice and complete tasks by itself.

Activate ASR

- From standby mode, press and hold , , or the external speaker button.

Tip: You can also activate ASR and use certain features with the phone closed. Press and hold the external speaker button while in standby mode, and follow the voice prompts.

The phone prompts you to say the name of the command you want to use. To complete your task, simply follow the voice prompts.

Available ASR commands include:

- **Call** <Name or #> to call an entry in your Contacts list or a spoken phone number. See [Make a Voice Call Using ASR](#) for details.
- **Send Message** <Name or #> to send a message to an entry in your Contacts list or to a spoken phone number. See [Send a Message Using ASR](#) for details.
- **Lookup** <Name> to display the detail screen of an entry in your Contacts list. See [Display a Contacts Entry's Information Using ASR](#) for details.
- **Go To** <Menu> to jump directly to menu items or applications. See [Open Menus Using ASR](#) for details.

- **Check** <Item> to check your phone's status. See [Check Phone Status Using ASR](#) for details.

Tip: Use ASR in a quiet environment so it can accurately recognize your commands.

Tip: During ASR operation, press **TUTORIAL** (left softkey) or **HELP** (left softkey) to get instructions for using the software.

Make a Voice Call Using ASR

1. Press and hold, , or the external speaker button.
2. When you hear "Say a command," say "**Call.**"
3. When you hear "Say the name or number," say a name or a phone number.
4. When you hear "Which location?," say a number type (for example, "Mobile").

Tip: You can skip steps 3 and 4 by saying a name and location after "Call" without pausing (for example, "**Call John Jones mobile**").

Note: If ASR does not recognize the name, it will find the most likely matches and display a list of up to three names or numbers. You will hear "Did you say Call?" followed by the name or number. You can confirm by saying "Yes." Say "No" to change the selection.

Send a Message Using ASR

1. Press and hold, , or the external speaker button.
2. When you hear "Say a command," say "**Send Message.**"
3. When you hear "Say the name or number," say a name or a phone number.
4. When you hear "Which location?," say a number type (for example, "Mobile"). The phone displays the text entry screen. See page [Messaging](#) for how to compose a message.

Display a Contacts Entry's Information Using ASR

1. Press and hold, , or the external speaker button.
2. When you hear "Say a command," say "**Lookup.**"
3. When you hear "Say the name," say a Contacts entry's name. The phone displays the detail screen for that Contacts entry.

Open Menus Using ASR

You can jump directly to many menu items or applications by saying "Go to" followed by a menu option.

1. Press and hold, , or the external speaker button.
2. When you hear "Say a command," say "**Go To.**"
3. When you hear "Which shortcut?," say an application name (for example, "Messaging").

4. The phone opens the selected menu.

Tip: Say “**More options**” to display additional application names.

Check Phone Status Using ASR

You can use ASR to obtain information about your phone:

- **Status** (all of the following except My Phone Number)
 - **Time**
 - **Signal Strength**
 - **Network**
 - **Battery**
 - **My Phone Number**
1. Press and hold, , or the external speaker button.
 2. When you hear “Say a command,” say “**Check.**”
 3. When you hear “Which status item?,” say a command.

ASR Settings

To change ASR confirmation:

1. Press and hold, , or the external speaker button.
2. Press **SETTINGS** (right softkey) > **Confirmation**.
 - **Automatic** to ask for confirmation only when the system is not sure what you said.
 - **Always Confirm** to always ask for confirmation.
 - **Never Confirm** to never ask for confirmation.

To adapt the system to your voice:

1. Press and hold, , or the external speaker button.
2. Press **SETTINGS** (right softkey) > **Adaptation** > **Adapt Voice**.
3. Press **START** (left softkey) and repeat each word, phrase, or telephone number you hear.

To reset the adaptation:

1. Press and hold, , or the external speaker button.

2. Press **SETTINGS** (right softkey) > **Adaptation** > **Reset Voice** > **YES** (left softkey).

To change the ASR mode:

1. Press and hold, , or the external speaker button.
2. Press **SETTINGS** (right softkey) > **Audio Modes**.
3. Highlight an option and press.
 - **Expert Mode** to sound a beep only.
 - **Prompt Mode** to prompt for required information.
 - **Readout Mode** to prompt for required information and to read the text displayed on the main screen.

To change the ASR dialing region:

1. Press and hold, , or the external speaker button.
2. Press **SETTINGS** (right softkey) > **Dialing Region**.
3. Highlight an option and press.
 - **North America** to recognize only numbers valid in North America.
 - **Other** to recognize any number regardless of location.

To display the ASR software version:

1. Press and hold, , or the external speaker button.
2. Press **SETTINGS** (right softkey) > **About**.



Manage Voice Memos

Use your phone's Voice Memo to record brief memos to remind you of important events, phone numbers, or grocery list items and to record call memos of the other party's voice during a phone call.

Note: You can store up to 600 memos on your phone. Maximum recording time depends on the available memory space on your phone.

Record Voice Memos

To record an audio memo:

1. Press > **Tools** > **Voice Services** > **Voice Memo** > **Record**.
2. Start recording after the beep.
3. To end the recording, press , , or **STOP** (right softkey).

To record the other party's voice during a phone call:

1. During a call, press **OPTIONS** (right softkey) > **Voice Memo**.
2. Start recording after the beep.

Note: Only the other party's voice is recorded during this process.

3. To stop recording, press **END** or **STOP** (left softkey).

Play Voice Memos

To play one or all memos:

1. Press > **Tools** > **Voice Services** > **Voice Memo** > **List**.
2. Select **In Phone** or **Memory Card**.
3. Highlight the memo you want to play and press.

– or –

Press **OPTIONS** (right softkey) > **Play** > **All** to play all memos continuously.

To play multiple memos:

1. Press > **Tools** > **Voice Services** > **Voice Memo** > **List**.
2. Select **In Phone** or **Memory Card**.
3. Press **OPTIONS** (right softkey) > **Play** > **Multiple** and select memos you want to play.
4. Press **PLAY** (left softkey).

Voice Memo Options

Your phone offers several options for managing voice memos you have recorded.

1. Press > **Tools** > **Voice Services** > **Voice Memo** > **List**.
2. Select **In Phone** or **Memory Card**.
3. Highlight a memo and press **OPTIONS** (right softkey) to display available voice memo options:
 - **Play** to play selected memos or all memos.
 - **Speaker On** or **Speaker Off** to activate or deactivate the speakerphone mode.
 - **Edit Title** to edit the title of a memo.
 - **Properties** to display information about a memo.
 - **Type Filter** to filter only audio memos, only call memos, or to display all memos.

- **Sort by** to sort memos by time recorded, name, or file size.
- **Go to Time** to set the point from which the memo starts playing.
- **Go to Card/Go to Phone** to switch between memos recorded on the memory card and to the In Phone folder.
- **Send Media** to send a memo by attaching it to a message.
- **Send via Bluetooth** to send memos via Bluetooth.
- **Copy to Card/Copy to Phone** to copy selected memos to the memory card or to the In Phone folder.
- **Move to Card/Move to Phone** to move selected memos to the memory card or to the In Phone folder.
- **Delete** to delete either selected memos or all memos. Select from **This**, **Multiple**, or **All**.

Calculator

Your phone comes with a built-in calculator.

1. Press > **Tools** > **Calculator**.
2. Enter numbers using your keypad.
 - Press the appropriate key for an arithmetic option (+ - × ÷).
 - Press the left softkey to enter a decimal point.
 - Press **CLEAR** (right softkey) to clear all numbers.
3. Press for the total.

World Clock

To view the time in different locations:

1. Press > **Tools** > **World Clock**.
2. Press the navigation key left or right to scroll through different time zones.

Note: Press **OPTIONS** (right softkey) > **Standard** or **Summer** to change between daylight saving time and standard time.

Countdown Timer

This feature allows you to use your phone as a countdown timer to alert you when a specified period of time has elapsed. You can set up to five timers.

1. Press **> Tools > Countdown.**
2. Highlight a countdown timer number and press.
3. Highlight a setting and press.
 - **Time** to enter the length of the countdown.
 - **Alarm** to set the countdown alarm to on or off.
4. Press **SAVE** (left softkey).

Tip: Press **ON** or **OFF** (left softkey) to toggle the countdown alarm on and off.

Stopwatch

You can record split times or lap times with the built-in stopwatch.

1. Press **> Tools > Stopwatch.**
2. Press **MODE** (left softkey) to select split timing or lap timing.
3. Press **START** (right softkey) to start the stopwatch.
4. Press **SPLIT** or **LAP** (left softkey) to record the time.
5. Press **STOP** (right softkey) to stop timing.
6. Press **RESET** (left softkey) to reset the stopwatch to zero.

Web and Data

Your phone's data capabilities let you wirelessly access the Internet. This section addresses your phone's data connections and the built-in Web browser.

Data Services

Browser

Download Games, Ringers, and More

Data Services

With your Sprint service, you are ready to start enjoying the advantages of data services. This section will help you learn the basics of using your data services, including managing your user name, launching a data connection, and navigating the Web with your phone.

Your User Name

Launch a Web Connection

Data Connection Status and Indicators

Your User Name

When you buy your phone and sign up for service, you're automatically assigned a user name, which is typically based on your name and a number, followed by "@sprintpcs.com." (For example, the third John Smith to sign up for Sprint data services might have jsmith003@sprintpcs.com as his user name.)

When you use data services, your user name is submitted to identify you to the Nationwide Sprint Network. Your user name will be automatically programmed into your phone. You don't have to enter it.

Find Your User Name

If you aren't sure what your user name is, you can easily find it on your phone.

Press > **Settings** > **Phone Info** > **Phone#/User ID**.

Update Your User Name

If you choose to change your user name and select a new one online, or make any changes to your services, you must then update the profile on your phone.

Press > **Settings** > **Others** > **Data Settings** > **Update Data Profile**. (To cancel, press  before completing the update.)

Launch a Web Connection

Launching a Web connection is as simple as opening the browser on your phone.

Press > **Web**. (Your data connection starts and you see the SprintWebSM home page.)

Note: If Net Guard is enabled and displayed (see [Net Guard](#)), press **YES** (left softkey) to continue and launch the Web.

While connecting, you may see an animation before the home page appears.

Tip: To change the default launch page to the last page you viewed, press **Options** (right softkey) and select **Browser settings > Startup page > Use the last page I visited > Confirm** (left softkey).

Data Connection Status and Indicators

Your phone displays the current status of your data connection through indicators at the top of the screen. The following symbols are used:

Your phone is within the Sprint data network service area. This icon animated while your phone is transferring data (for example, when you are opening a Web page).

Your phone is within the Sprint data network service area, but you are not transferring data (for example, when you are viewing a Web page that has already been opened), or you are signed out or disconnected from the data network.

Your phone is outside of the Sprint data network service area.

Browser

Your phone's Web browser gives you access to websites on the go, using data connections.

[Learn to Navigate the Web](#)

[Browser Menu](#)

Learn to Navigate the Web

Navigating through menus and websites during a data session is easy once you've learned a few basics.

Note: Before you access the SprintWebSM home page, you may be asked to enter your ten-digit wireless phone number and press. Entering your phone number is not required for access to other Web pages.

Softkeys

During a data session, the bottom line of your phone's display screen contains one or more softkeys. These keys are shortcut controls for navigating around the Web, and they correspond to the softkeys directly below the phone's display screen.

Tip: Depending on which websites you visit, the labels on the softkeys may change to indicate their function.

To use softkeys:

- Press a softkey. (If an additional pop-up menu is displayed when you press the softkey, select the menu items using your keypad [if they're numbered], or by highlighting the option and pressing.)

Scrolling

As with other parts of your phone's menu, you'll have to scroll up and down to see everything on some websites.

To scroll line by line through websites:

- Press the navigation key up or down.

Selecting

Once you've learned how to use softkeys and scroll, you can start navigating the Web.

To select onscreen items:

- Use the navigation key to highlight an item, and then press the left softkey (or press).

Tip: You'll find that the left softkey is used primarily for selecting items. This softkey is often labeled "GO."

Tip: If the items on a page are numbered, you can use your keypad (number keys) to select an item.

Links, which are displayed as underlined text, allow you to jump to Web pages, select special functions, or even place phone calls.

To select links:

- Highlight the link and press the appropriate softkey.

Go Back

To go back one page:

- Press  on your phone.

Tip: You can also use  for deleting text (like a BACKSPACE key) when you are entering text.

Go Home

To return to the home page from any other page:

- Press and hold .

Browser Menu

Although the SprintWebSM home page offers a broad and convenient array of sites and services for you to browse, not all sites are represented, and certain functions, such as going directly to specific websites, are not available. For these and other functions, you will need to use the browser menu. The browser menu offers additional options to expand your use of the Web on your phone.

Open the Browser Menu

You may open the browser menu anytime you have an active data session, from any page you are viewing.

- From any open Web page, press **Navigation** (left softkey). Use a navigation key for the following operations.

To open a specific page:

- Highlight a text input field on the top, enter a URL and press.

To open a new window:

- Highlight a page icon labeled **Open a new page** and press.

To switch windows:

- Highlight a page icon you want to display and press.

To close a window:

- Highlight a cross mark on the top right of a page icon you want to close and press.

To go back a page:

- Highlight  and press.

To go forward a page:

- Highlight  and press.

To reload a page:

Highlight and press.

Open the Browser Options:

From any open Web page, press **Options** (right softkey).

Options available within the browser menu include:

- to change the display font size on the Web page.
- **Search the web** to launch a Web search.
- **Add this page to bookmarks** to store the address of the currently viewed Web page.
- **View all bookmarks** to display a bookmark list.
- **View browsing history** to display a list of the Web pages visited.
- **Send this page to a friend** to send a URL of the currently viewed Web page.
- **Overview mode** to display the entire web page.
- **Browser settings**
 - **Startup page** to change the default launch page.
 - **Automatic overview mode** to change the default view to overview mode.
 - **Default zoom size** to select the zoom value.
 - **Do not show images/Show images** to display or hide the images on the Web page.
 - **Icon row** to display or hide the area showing icons.
 - **Popups** to allow or block the popups.
 - **Clear private data** to delete the cookies, cache, history, or stored passwords.
 - **Advanced**
 - **Page information** to display information about the currently viewed page.
 - **Browser information** to display information about the browser.
 - **Disable Javascript/Enable Javascript** to disable or enable Java scripting.
 - **Disable Error Log/Enable Error Log** to set whether to save error logs (text files useful for debugging browser errors). To display the error log, select the **View error log** option from the submenu (available only when the error log is enabled).

- **Do not send referrer header/Send referrer header** to set whether to send HTTP URL referrer information.
- **Turn off redirect prompt/Turn on redirect prompt** to set whether to display a prompt when your data is being redirected.
- **Root certificate** to display the certifications.
- **Disable virtual mouse/Enable virtual mouse** to activate or deactivate the virtual mouse.
- **Virtual mouse** to set the speed of the virtual mouse.
- **Reset browser** to reset all browser settings.

Download Games, Ringers, and More

You have access to a dynamic variety of downloadable content, such as games, ringers, screen savers, and other applications. (Additional charges may apply.) Follow the basic steps below to access and download these items.

Access the Download Menus

1. Press > **My Stuff**.
2. Select a download category (**Games, Ringers, Screen Savers, or Applications**), and then select **Get New**.

– or –

Select **Call Tones**. (The browser will start and take you to the corresponding download menu.)

– or –

1. From the SprintWebSM home page, select **Downloads**, and then select **Sprint Downloads**.
2. Select a download category (**Call Tones, Games, Ringers, Screen Savers, or Applications**) to go to the corresponding download menu. For more information on navigating the Web, see [Learn to Navigate the Web](#).

Select an Item to Download

You can search for available items to download in a number of ways:

- **Featured** displays a selection of featured items.

- **Categories** allows you to narrow your search to a general category. (There may be several pages of available content in a list. Select **Next 9** to view additional items.)
- **Search** allows you to use your keypad to enter search criteria to locate an item. You may enter an entire word or title or perform a partial-word search.

Download an Item

Once you've selected an item you wish to download, highlight it and press. You will see a summary page for the item including its title, the vendor, the download details, and the cost. Links allow you to view the **License Info** page, which outlines the price, license type, and length of license for the download, and the **Terms of Use** page, which details the Premium Services Terms of Use and your responsibility for payment.

To download a selected item:

1. From the information page, use your navigation key to move the cursor over **Buy**. When the cursor changes from an arrow into a hand, press. The item will download automatically. When you see the **NEW DOWNLOAD** screen, you have successfully downloaded the item to your phone. (When you download a call tone, you will not see the **NEW DOWNLOAD** screen. Instead, you will see a screen giving you the option to set the downloaded call tone as your default.)

Note: If you have not previously purchased an item, you will be prompted to create your purchasing profile.

2. Select an option to continue:
 - Select a menu such as **Run/Open/Listen/View/Play** to start the downloaded item. Your data session will end, and your phone will redirect you to the appropriate phone menu screen.
 - Select **Assign** to assign a ringer or screen saver to a phone function.
 - Select **Settings** to configure downloaded games or applications.
 - Select **Shop** to browse for other items to download.
 - Press  to quit the browser and return to standby mode.

My Content Manager

Whether you purchase your content from your phone or from your online account management page at sprint.com, **My Content Manager** stores all of your purchases and you may download them to your phone from there.

My Content Manager is a storage area on the Nationwide Sprint Network that allows you to store all your purchased files. The files remain in My Content Manager until their license terms have expired—even after you have downloaded the content to your phone. This provides you

with a convenient place to access information about your downloaded files without having to store the information in your phone's memory.

To access My Content Manager:

1. From the SprintWebSM home page, select **Categories > Downloads > My Content Manager**. (You will see a list of your purchased items.)
2. Highlight a category and press. (You will see your downloads for that category.)

To download purchased content from My Content Manager:

1. From the **My Content Manager** display, highlight the item you wish to download, and press. (You will see the information page for the selected item.)
2. Highlight **Download** and press. The item will download automatically. When you see the **NEW DOWNLOAD** screen, you have successfully downloaded the item to your phone. (When you download a call tone, you will not see the **NEW DOWNLOAD** screen. Instead, you will see a screen giving you the option to set the downloaded call tone as your default.)
3. Select an option to continue:
 - Select a menu such as **Run/Open/Listen/View/Play** to start the downloaded item. Your data session will end, and your phone will redirect you to the appropriate phone menu screen.
 - Select **Assign** to assign a ringer or screen saver to a phone function.
 - Select **Settings** to configure downloaded games or applications.
 - Select **Shop** to browse for other items to download.
 - Press  to quit the browser and return to standby mode.

Tip: You can also access My Content Manager through the phone's main menu. Go to **My Stuff > [Games, Ringers, Screen Savers, Applications, or IM & Email] > My Content Manager**. The browser will open and take you to the corresponding content.

For complete information and instructions on downloading **Games, Ringers, Screen Savers, and Applications**, visit the Digital Lounge at sprint.com.

GPS Navigation

Your phone's built-in GPS capability gives you access to a number of location-based services.

[GPS Services](#)

[GPS Navigation](#)

[Sprint Family Locator](#)



GPS Services

Before using any of the location-based services, you must turn on your phone's location mode.

Activate Location Mode

To enable your phone's Location feature:

1. Press > **Settings** > **Others** > **Location** > **On/Off**. (You will see the Location disclaimer.)
2. Read the disclaimer and press.
3. Select **On**.

When the Location feature is on, your phone's standby screen will display the  icon. When Location is turned off, your phone will display the  icon.

To send the GPS log to other devices:

1. Press > **Settings** > **Others** > **Location** > **NMEA Output**.
2. Select **Bluetooth** or **USB**.

Note: Turning Location on will allow the network to detect your position using GPS technology, making some Sprint applications and services easier to use. Turning Location off will disable the GPS location function for all purposes except 911, but will not hide your general location based on the cell site serving your call. No application or service may use your location without your request or permission. GPS-enhanced 911 is not available in all areas.

GPS Navigation

Sprint Navigation gives you turn-by-turn directions onscreen and over speakerphone.

Note: Depending on your service plan, Sprint Navigation may require a monthly subscription. Contact Sprint for information and pricing.

Register Sprint Navigation

Before you can use Sprint Navigation, your phone and service must be registered.

1. Press > **Maps** > **Sprint Navigation**.
2. Follow the onscreen instructions to enter and submit the required information.

Use Sprint Navigation

1. Press > **Maps** > **Sprint Navigation**.
2. Select an option and follow the onscreen instructions to get directions or view maps.
 - **Drive To** lets you enter an address (vocally or using the keypad) or select from categories such as **My Favorites**, **Recent Places**, or **Businesses** to search for turn-by-turn directions.
 - **Search** provides a categorized list of locations such as **Gas Stations**, **Grocery Stores**, and **Hospitals** to help find local businesses and services.
 - **Maps & Traffic** lets you view maps and get traffic information for your current location or for any other location (same categories as **Drive To**).
 - **Share & More** provides access to additional services such as **Share Address**, **Record Location**, and **Preferences**.

Note: For more information about Sprint Navigation, visit sprint.com/navigation.

Sprint Family Locator

Sprint Family Locator uses GPS technology to locate your child's phone and display the location on an interactive map.

Note: Sprint Family Locator service requires an additional monthly fee. Visit sprint.com/familylocator for complete details.

Sign Up for Sprint Family Locator

1. Press > **Maps** > **Sprint Family Locator**.
2. Follow the onscreen instructions to enter and submit the required information.

Note: You can also sign up for Sprint Family Locator online at sprint.com/familylocator.

Use Sprint Family Locator

1. Press > **Maps** > **Sprint Family Locator**.
2. Enter the parent phone number and password to sign in to your account.

3. Select a phone to locate from the available child phone list.
4. When you are finished, select **Sign Out**.

Note: You may also use Sprint Family Locator with any computer with an Internet connection. Visit sprint.com/familylocator for complete details.

Copyrights

©2011 Sprint. SPRINT and the logo are trademarks of Sprint. KYOCERA is a registered trademark of Kyocera Corporation. Other marks are the property of their respective owners.

This product contains NetFront Browser of ACCESS CO., LTD. ACCESS and NetFront are trademarks or registered trademarks of ACCESS CO., LTD. in Japan and other countries. This software is based in part on the work of the Independent JPEG Group.

The Bluetooth word mark and logos are owned by the Bluetooth SIG, Inc. and any use of such marks by Kyocera Corporation is under license. Other trademarks and trade names are those of their respective owners.

T9[®] is a registered trademark of Nuance Communications, Inc. and its affiliates in the United States and other countries. Copyright © 2011 Nuance Communications, Inc. All rights reserved.