

OPERATION GUIDE

FS-1028MFP/FS-1128MFP



Introduction

Thank you for your purchase of FS-1028MFP/FS-1128MFP.

This Operation Guide is intended to help you operate the machine correctly, perform routine maintenance and take a simple troubleshooting action as necessary, so that you can always use the machine in good condition.

Please read this Operation Guide before you start using the machine, and keep it close to the machine for easy reference.

We recommend the use of our own brand supplies. We will not be liable for any damage caused by the use of third party supplies in this machine.

This Operation Guide also includes instructions on FS-1028MFP/DP.

Included Guides

The following guides are supplied with the machine. Refer to them as necessary.

Operation Guide (This Guide)

Describes how to load paper, basic copy, print and scan operations, and troubleshooting.

Safety Conventions in This Guide

The sections of this guide and parts of the machine marked with symbols are safety warnings meant to protect the user, other individuals and surrounding objects, and ensure correct and safe usage of the machine. The symbols and their meanings are indicated below.



WARNING: Indicates that serious injury or even death may result from insufficient attention to or incorrect compliance with the related points.



CAUTION: Indicates that personal injury or mechanical damage may result from insufficient attention to or incorrect compliance with the related points.

Symbols

The \triangle symbol indicates that the related section includes safety warnings. Specific points of attention are indicated inside the symbol.



.... [General warning]



.... [Warning of danger of electrical shock]



.... [Warning of high temperature]

The \otimes symbol indicates that the related section includes information on prohibited actions. Specifics of the prohibited action are indicated inside the symbol.



.... [Warning of prohibited action]



.... [Disassembly prohibited]

The \bullet symbol indicates that the related section includes information on actions which must be performed. Specifics of the required action are indicated inside the symbol.



.... [Alert of required action]



.... [Remove the power plug from the outlet]



.... [Always connect the machine to an outlet with a ground connection]

Please contact your service representative to order a replacement if the safety warnings in this Operation Guide are illegible or if the guide itself is missing (fee required).

NOTE: An original which resembles a bank note closely may not be copied properly in some rare cases because this machine is equipped with a counterfeiting prevention function.

Contents

	Caution / Warning Labels	v
	Installation Precautions	vi
	Precautions for Use	viii
	Laser Safety (Europe)	xii
	Safety Instructions Regarding the Disconnection of Power (Europe)	xiii
	SAFETY OF LASER BEAM (USA)	xiv
	Safety Instructions Regarding the Disconnection of Power (USA)	xvi
	Legal Restriction on Copying/Scanning	xviii
	Legal and Safety Information	xix
1	Part Names	
	Operation Panel	1-2
	Machine	1-4
2	Preparation before Use	
	Check bundled items	2-2
	Determining the Connection Method and Preparing Cables	2-3
	Connecting Cables	2-5
	Switching the Language for Display [Language]	2-7
	Setting Date and Time	2-9
	Network Setup (LAN Cable Connection)	2-12
	Installing Software	2-24
	COMMAND CENTER (Settings for E-mail)	2-25
	Sending E-mail	2-26
	Loading Paper	2-28
	Loading Originals	2-44
3	Basic Operation	
	Power On/Off	3-2
	Auto Low Power Mode	3-4
	Sleep and Auto Sleep	3-5
	Login/Logout	3-6
	One-Touch Keys and Program Keys	3-7
	Message Display	3-8
	Copying	3-9
	Printing - Printing from Applications	3-18
	Sending	3-20
	Confirm Destination Screen	3-27
	Specifying Destination	3-28
	Canceling Jobs	3-31
	Checking Remaining Toner and Paper	3-32
	Program (Copying and Sending)	3-33
4	Copying Functions	
	Original Size	4-2
	Paper Selection	4-4
	Original Orientation	4-8
	EcoPrint	4-10
	Combine Mode	4-11
	Continuous Scan	4-15

	Job Finish Notice	4-16
	File Name Entry	4-18
	Print Override	4-19
5	Sending Functions	
	Original Size	5-2
	Sending Size	5-4
	Zoom	5-6
	Duplex Sending	5-7
	Original Orientation	5-8
	File Format	5-10
	Original Image	5-12
	Adjusting Density	5-13
	Scan Resolution	5-14
	Color / Grayscale / Black and White Selection	5-15
	Continuous Scan	5-16
	File Name Entry	5-17
	Subject and Body Entry	5-18
	WSD Scan	5-19
	Job Finish Notice	5-21
	FTP Encrypted TX	5-23
	Sanning Image using Application	5-24
6	Document Box	
	Printing Documents Stored in USB Memory	6-2
	Saving Documents to USB Memory (Scan to USB)	6-4
	Removing USB Memory	6-6
7	Status / Job Cancel	
	Checking Job Status	7-2
	Checking Job History	7-8
	Sending the Job Log History	7-13
	Pause and Resumption of Jobs	7-19
	Canceling of Jobs	7-19
	Device/Communication	7-20
8	Default Setting (System Menu)	
	Common Settings	8-2
	Copy Settings	8-56
	Sending Settings	8-62
	Document Box Settings	8-66
	Printer Settings	8-69
	Printing Reports/Sending Notice	8-81
	Adjustment/Maintenance	8-87
	Date/Timer	8-92
	Editing Destination (Address Book/Adding One-Touch Keys)	8-112
	Restarting the System	8-127
	Network Setup	8-128
	Network Security	8-138
	Interface Block Setting	8-146
	Security Level (Security Level setting)	8-150
	Optional Functions	8-151

9	Maintenance	
	Cleaning	9-2
	Toner Container	9-5
10	Troubleshooting	
	Solving Malfunctions	10-2
	Responding to Error Messages	10-5
	Clearing Paper Jams	10-11
11	Management	
	User Login Administration	11-2
	Job Accounting	11-13
	Checking the Counter	11-37
	Appendix	
	Optional EquipmentAppendix-2
	Character Entry MethodAppendix-5
	PaperAppendix-9
	SpecificationsAppendix-18
	GlossaryAppendix-23
	Index	

Caution / Warning Labels

Caution / Warning labels have been attached to the machine at the following locations for safety purposes. Be sufficiently careful to avoid fire or electric shock when removing a paper jam or when replacing toner.

Laser inside the machine (Laser radiation warning)

DANGER CLASS 3B INVISIBLE LASER RADIATION WHEN OPEN. AVOID DIRECT EXPOSURE TO BEAM.
ATTENTION CLASS 3B RAYONNEMENT LASER INVISIBLE EN CAS D'OUVERTURE. EXPOSITION DANGEREUSE AU FASCEAU.
VORSICHT KLASSE 3B UNSICHTBARE LASERSTRAHLUNG, WENN ABDECKUNG GEÖFFNET. NICHT DEM STRAHL AUSSETZEN.
ATTENZIONE CLASSE 3B RADIAZIONE LASER INVISIBLE IN CASO DI APERTURA. EVITARE L'ESPOSIZIONE AL FASCO.
PRECAUCION CLASSE 3B RADIACIONE LASER INVISIBLE CUANDO SE ABRE. EVITAR EXPOSERSE AL RAYO.
VARO! AVATTARESSA OLET ALTITINA LUOKAN 3B NÄKYMÄTTÖMÄLLE LASERIRÄTEVYLLE. ÄLÄ KATSO SÄTEESEEN.
警告 该产品为3B级不可见激光产品。打开盖子后会有激光辐射。请避免光束照射。
警告 该产品为3B级不可见激光产品。打开盖子后会有激光辐射。请避免光束照射。
위험 CLASS 3B 레이저광선용 직접 보지마십시오.
警告 この装置はクラス3B不可見レーザー光が放射します。
注意 直射光を避け、直射光を避けてください。

CAUTION
HOT SURFACE
ACHTUNG
HEISSE OBERFLÄCHE
ATTENTION
TEMPERATURE ÉLEVÉE
ATTENCIÓN
EXTERIOR CALIENTE
ATTENZIONE
SUPERFICIE CHE SCOTIA
高温注意
고온 주의

High temperature inside. Do not touch parts in this area, because there is a danger of getting burned.

For U.S.A. and Canada

FS-1028MFP
 AC 120V 60Hz 7.8A
 TAMAKI PLANT
 704-19 NOJINO, TAMAKI-TOWN
 WATARAI-COUNTY, MIE-PREF. JAPAN
 MANUFACTURED: C11

Contains FCC ID : E522KP0110
 Contains IC : 1059B-2KP0110

This device complies with Part 15 of the FCC Rules. Operation is subject to the following two conditions: (1) This device may not cause harmful interference, and (2) this device must accept any interference received, including interference that may cause undesired operation.

This Class B digital apparatus complies with Canadian ICES-005.
 Cet appareil numérique de la classe B est conforme à la norme NMB-003 du Canada.

Complies with FDA radiation performance standards 21 CFR Subchapter J.

• REMOVE POWER CORD BEFORE SERVICE AND FUSE REPLACEMENT.
 • POUR PRÉVENIR LES CHOCS ÉLECTRIQUES, COUPER L'ALIMENTATION AVANT DE REMPLACER LE FUSIBLE.

>ABS<

KYOCERA MITA Corporation
 DESIGNED IN JAPAN / ASSEMBLED IN CHINA

For Europe, Asia, and other countries

FS-1128MFP
 AC 220-240V 50/60Hz 4.0A
 • Apparatet må tilsluttes jordet stikkontakt.
 • Apparatet skall anslutas till jordat uttag.
 • Laitte on liitettävä suojamaadoituskeskittimillä varustettuun pistosasiaan.

CLASS 1 LASER PRODUCT
KLASSE 1 LASER PRODUKT

• REMOVE POWER CORD BEFORE SERVICE.
 • VOR WARTUNG BITTE NETZSTECKER ZIEHEN.
 • POUR PRÉVENIR LES CHOCS ÉLECTRIQUES, COUPER L'ALIMENTATION AVANT DE MANIPULER.
 • DESHONRARE EL CORDON DE ALIMENTACIÓN ANTES DEL SERVICIO.
 • PRIMA DI ESEGUIRE RIPARAZIONI, STACARE IL CAVO DI ALIMENTAZIONE.

>ABS<

KYOCERA MITA Corporation
 DESIGNED IN JAPAN / ASSEMBLED IN CHINA

NOTE: Do not remove these labels.

Installation Precautions

Environment

CAUTION

Avoid placing the machine on or in locations which are unstable or not level. Such locations may cause the machine fall down or fall over. This type of situation presents a danger of personal injury or damage to the machine.



Avoid locations with humidity or dust and dirt. If dust or dirt become attached to the power plug, clean the plug to avoid the danger of fire or electrical shock.



Avoid locations near radiators, heaters or other heat sources, or locations near flammable items to avoid the danger of fire.



To keep the machine cool and facilitate changing of parts and maintenance, allow access space as shown below. Leave adequate space, especially around the rear cover, to allow air to be properly ventilated out of the machine.

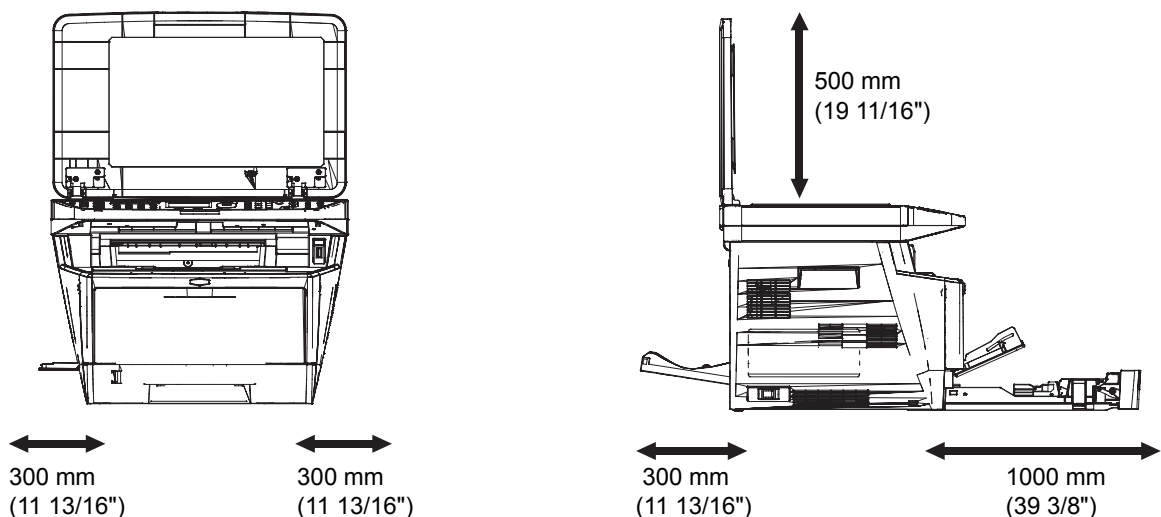

Other precautions

The service environmental conditions are as follows:

- Temperature: 50 to 90.5 °F (10 to 32.5 °C)
- Humidity: 15 to 80 %

However, adverse environmental conditions may affect the image quality. Avoid the following locations when selecting a site for the machine.

- Avoid locations near a window or with exposure to direct sunlight.
- Avoid locations with vibrations.
- Avoid locations with drastic temperature fluctuations.

-
- Avoid locations with direct exposure to hot or cold air.
 - Avoid poorly ventilated locations.

If the floor is delicate against casters, when this machine is moved after installation, the floor material may be damaged.

During copying, some ozone is released, but the amount does not cause any ill effect to one's health. If, however, the machine is used over a long period of time in a poorly ventilated room or when making an extremely large number of copies, the smell may become unpleasant. To maintain the appropriate environment for copy work, it is suggested that the room be properly ventilated.

Power supply/Grounding the machine

WARNING

Do not use a power supply with a voltage other than that specified. Avoid multiple connections in the same outlet. These types of situations present a danger of fire or electrical shock.



Plug the power cord securely into the mains power outlet and the power socket on the machine. A buildup of dust around the prongs on the plug or contact between the prongs and metallic objects may cause a fire or electric shock. Incomplete electrical contact could cause overheating and ignition.



Always connect the machine to an outlet with a ground connection to avoid the danger of fire or electrical shock in case of an electric short. If an earth connection is not possible, contact your service representative.



Other precautions

Connect the power plug to the closest outlet possible to the machine.

Handling of plastic bags

WARNING

Keep the plastic bags that are used with the machine away from children. The plastic may cling to their nose and mouth causing suffocation.



Precautions for Use

Cautions when using the machine

WARNING

Do not place metallic objects or containers with water (flower vases, flower pots, cups, etc.) on or near the machine. This type of situation presents a danger of fire or electrical shock should they fall inside.



Do not remove any of the covers from the machine as there is a danger of electrical shock from high voltage parts inside the machine.



Do not damage, break or attempt to repair the power cord. Do not place heavy objects on the cord, pull it unnecessarily or cause any other type of damage. These types of situations present a danger of fire or electrical shock.



Never attempt to repair or disassemble the machine or its parts as there is a danger of personal injury, fire, electrical shock or exposure to the laser. If the laser beam escapes, there is a danger of it causing blindness.



If the machine becomes excessively hot, smoke appears from the machine, there is an odd smell, or any other abnormal situation occurs, there is a danger of fire or electrical shock. Turn the main power switch off immediately, be absolutely certain to remove the power plug from the outlet and then contact your service representative.



If anything harmful (paper clips, water, other fluids, etc.) falls into the machine, turn the main power switch off immediately. Next, remove the power plug from the outlet to avoid the danger of fire or electrical shock. Then contact your service representative.



Do not remove or connect the power plug with wet hands, as there is a danger of electrical shock.



Always contact your service representative for maintenance or repair of internal parts.



CAUTION

Do not pull the power cord when removing it from the outlet. If the power cord is pulled, the wires may become broken and there is a danger of fire or electrical shock. (Always grasp the power plug when removing the power cord from the outlet.)



Always remove the power plug from the outlet when moving the machine. If the power cord is damaged, there is a danger of fire or electrical shock.



Always hold the designated parts only when lifting or moving the machine.



If this machine will be left unused for an extended period (e.g. overnight), turn it off at the main power switch. If the machine will not be used for an even longer period of time (e.g. vacation), remove the power plug from the outlet as a safety precaution. If using the FS-1128MFP, note that turning the machine off at the main power switch disables fax transmission and reception.



For safety purposes, always remove the power plug from the outlet when performing cleaning operations.



If dust accumulates within the machine, there is a danger of fire or other trouble. It is therefore recommended that you consult with your service representative in regard to cleaning of internal parts. This is particularly effective if accomplished prior to seasons of high humidity. Consult with your service representative in regard to the cost of cleaning the internal parts of the machine.



Other precautions

Do not place heavy objects on the machine or cause other damage to the machine.

Do not open the front cover, turn off the main power switch, or pull out the power plug during copying.

When lifting or moving the machine, contact your service representative.

Do not touch electrical parts, such as connectors or printed circuit boards. They could be damaged by static electricity.

Do not attempt to perform any operations not explained in this guide.

Caution: Use of controls or adjustments or performance of procedures other than those specified herein may result in hazardous radiation exposure.

Do not look directly at the light from the scanning lamp as it may cause your eyes to feel tired or painful.

Cautions when handling consumables

CAUTION

Do not attempt to incinerate the toner container or the waste toner box. Dangerous sparks may cause burns.



Keep the toner container and the waste toner box out of the reach of children.



If toner happens to spill from the toner container or the waste toner box, avoid inhalation and ingestion, as well as contact with your eyes and skin.



- If you do happen to inhale toner, move to a place with fresh air and gargle thoroughly with a large amount of water. If coughing develops, contact a physician.
- If you do happen to ingest toner, rinse your mouth with water and drink 1 or 2 cups of water to dilute the contents of your stomach. If necessary, contact a physician.
- If you do happen to get toner in your eyes, flush them thoroughly with water. If there is any remaining tenderness, contact a physician.
- If toner does happen to get on your skin, wash with soap and water.

Do not attempt to force open or destroy the toner container or the waste toner box.



If using the FS-1128MFP the main power switch is off, transmitting/receiving Fax is disabled. Do not turn off the main power switch, but press the **Power** key on the operation panel to enter Sleep mode.

Other precautions

Return the exhausted toner container and waste toner box to your dealer or service representative. The collected toner container and waste toner box will be recycled or disposed in accordance with the relevant regulations.

Store the machine while avoiding exposure to direct sunlight.

Store the machine in a place where the temperature stays below 40°C while avoiding sharp changes of temperature and humidity.

If the machine will not be used for an extended period of time, remove the paper from the cassette and the Multi Purpose (MP) Tray, return it to its original package and reseal it.

Laser Safety (Europe)

Laser radiation could be hazardous to the human body. For this reason, laser radiation emitted inside this machine is hermetically sealed within the protective housing and external cover. In the normal operation of the product by user, no radiation can leak from the machine.

This machine is classified as Class 1 laser product under IEC 60825.

Caution: Performance of procedures other than those specified in this manual may result in hazardous radiation exposure.

These labels are attached to the laser scanner unit inside the machine and are not in a user access area.

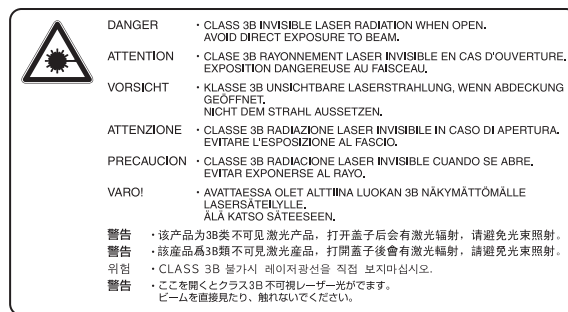

The label shown below is attached on the rear side of the machine.



Safety Instructions Regarding the Disconnection of Power (Europe)

Caution: The power plug is the main isolation device! Other switches on the equipment are only functional switches and are not suitable for isolating the equipment from the power source.

VORSICHT: Der Netzstecker ist die Hauptisoliervorrichtung! Die anderen Schalter auf dem Gerät sind nur Funktionsschalter und können nicht verwendet werden, um den Stromfluß im Gerät zu unterbrechen.



DECLARATION OF CONFORMITY TO

2004/108/EC, 2006/95/EEC, 93/68/EEC and 1999/5/EC

We declare under our sole responsibility that the product to which this declaration relates is in conformity with the following specifications.

EN55024

EN55022 Class B

EN61000-3-2

EN61000-3-3

EN60950-1

EN60825-1

EN300 330-1

EN300 330-2

TBR21

Radio Frequency Transmitter

This machine contains the transmitter module. We, the manufacturer hereby declare that this equipment is in compliance with the essential requirements and other relevant provisions of Directive 1999/5/EC.

Radio Tag Technology

In some countries the radio tag technology used in this equipment to identify the toner container may be subject to authorization and the use of this equipment may consequently be restricted.

NOTE: Product marked with the Crossed-out Wheeled Bin Symbol includes the battery that complies with the European Parliament and Council Directive 2006/66/EC (the "Battery Directive") in European Union.

Do not remove and dispose of the batteries included in this machine.



SAFETY OF LASER BEAM (USA)



1. Safety of laser beam

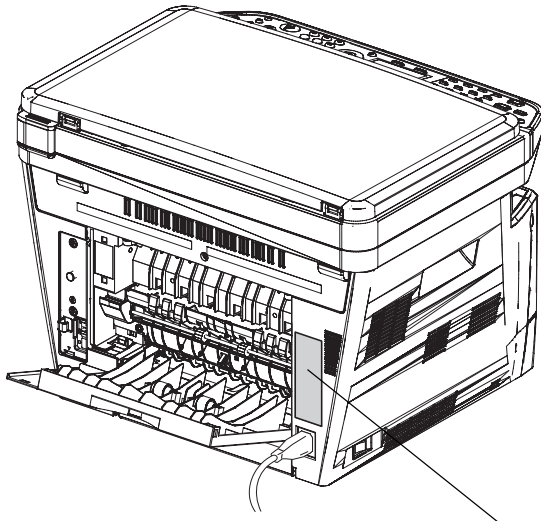

This machine has been certified by the manufacturer to Class 1 level under the radiation performance standards established by the U.S.DHHS (Department of Health and Human Services) in 1968. This indicates that the product is safe to use during normal operation and maintenance. The laser optical system, enclosed in a protective housing and sealed within the external covers, never permits the laser beam to escape.

2. The CDRH Act

A laser-product-related act was implemented on Aug. 2, 1976, by the Center for Devices and Radiological Health (CDRH) of the U.S. Food and Drug Administration (FDA). This act prohibits the sale of laser products in the U.S. without certification, and applies to laser products manufactured after Aug. 1, 1976. The label shown below indicates compliance with the CDRH regulations and must be attached to laser products marketed in the United States. On this machine, the label is on the rear.



FS-1028MFP
AC 120V 60Hz 7.8A
TAMAKI PLANT 704-19 NOJINO, TAMAKI-TOWN WATARAI-COUNTY, MIE-PREF. JAPAN MANUFACTURED: C11
 
Contains FCC ID : E522KP0110 Contains IC : 1059B-2KP0110
This device complies with Part 15 of the FCC Rules. Operation is subject to the following two conditions: (1) This device may not cause harmful interference, and (2) this device must accept any interference received, including interference that may cause undesired operation.
This Class B digital apparatus complies with Canadian ICES-003. Cet appareil numérique de la classe B est conforme à la norme NMB-003 du Canada.
Complies with FDA radiation performance standards 21 CFR Subchapter J.
*REMOVE POWER CORD BEFORE SERVICE AND FUSE REPLACEMENT. *POUR PRÉVENIR LES CHOCES ELECTRIQUES COUPER L'ALIMENTATION AVANT DE REMPLACER LE FUSIBLE. >ABS-C
KYOCERA MITA Corporation DESIGNED IN JAPAN / ASSEMBLED IN CHINA

FS-1128MFP
AC 120V 60Hz 7.8A
TAMAKI PLANT 704-19 NOJINO, TAMAKI-TOWN WATARAI-COUNTY, MIE-PREF. JAPAN MANUFACTURED: C11
 
Contains FCC ID : E522KP0110 Contains IC : 1059B-2KP0110
This device complies with Part 15 of the FCC Rules. Operation is subject to the following two conditions: (1) This device may not cause harmful interference, and (2) this device must accept any interference received, including interference that may cause undesired operation.
This Class B digital apparatus complies with Canadian ICES-003. Cet appareil numérique de la classe B est conforme à la norme NMB-003 du Canada.
Complies with FDA radiation performance standards 21 CFR Subchapter J.
*REMOVE POWER CORD BEFORE SERVICE AND FUSE REPLACEMENT. *POUR PRÉVENIR LES CHOCES ELECTRIQUES COUPER L'ALIMENTATION AVANT DE REMPLACER LE FUSIBLE. >ABS-C
KYOCERA MITA Corporation DESIGNED IN JAPAN / ASSEMBLED IN CHINA

3. Optical unit

When checking the optical unit, avoid direct exposure to the laser beam, which is invisible. Shown at below is the label located on the cover of the optical unit.

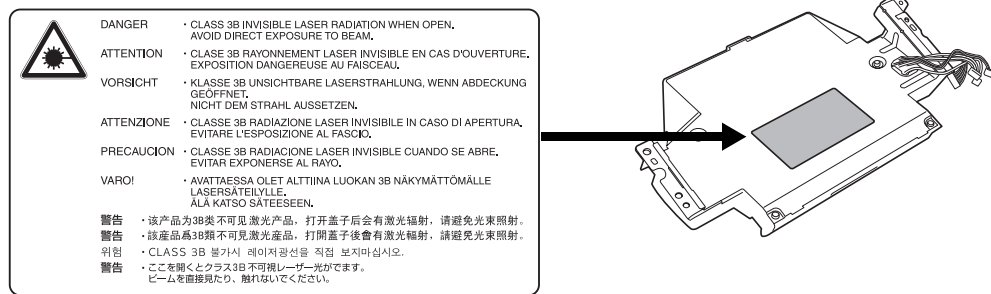

4. Maintenance

For safety of the service personnel, follow the maintenance instructions in the other section of this manual.

Safety Instructions Regarding the Disconnection of Power (USA)

Caution: The power plug is the main isolation device! Other switches on the equipment are only functional switches and are not suitable for isolating the equipment from the power source.

Attention: Le débranchement de la fiche secteur est le seul moyen de mettre l'appareil hors tension. Les interrupteurs sur l'appareil ne sont que des interrupteurs de fonctionnement: ils ne mettent pas l'appareil hors tension.

WARNING

This equipment has been tested and found to comply with the limits for a Class B digital device, pursuant to Part 15 of the FCC Rules. These limits are designed to provide reasonable protection against harmful interference in a residential installation. This equipment generates, uses and can radiate radio frequency energy and, if not installed and used in accordance with the instructions, may cause harmful interference to radio communications. However, there is no guarantee that interference will not occur in a particular installation. If this equipment does cause harmful interference to radio or television reception, which can be determined by turning the equipment off and on, the user is encouraged to try to correct the interference by one or more of the following measures:

- Reorient or relocate the receiving antenna.
- Increase the separation between the equipment and receiver.
- Connect the equipment into an outlet on a circuit different from that to which the receiver is connected.
- Consult the dealer or an experienced radio/TV technician for help.
- The use of a non-shielded interface cable with the referenced device is prohibited.

CAUTION — The changes or modifications not expressly approved by the party responsible for compliance could void the user's authority to operate the equipment.

This device complies with Part 15 of FCC Rules and RSS-Gen of IC Rules.

Operation is subject to the following two conditions; (1) this device may not cause interference, and (2) this device must accept any interference, including interference that may cause undesired operation of the device.

* The above warning is valid only in the United States of America.

Radio Tag Technology

In some countries the radio tag technology used in this equipment to identify the toner container may be subject to authorization and the use of this equipment may consequently be restricted.

MERCURY WARNING



THE LAMP(S) INSIDE THIS PRODUCT CONTAIN MERCURY AND MUST BE RECYCLED OR DISPOSED OF ACCORDING TO LOCAL, STATE OR FEDERAL LAWS.

Other precautions (for users in California, the United States)

This product contains a CR Coin Lithium Battery which contains Perchlorate Material - special handling may apply. See www.dtsc.ca.gov/hazardouswaste/perchlorate.

Warranty (USA)

FS-1028MFP/FS-1128MFP MULTIFUNCTIONAL PRODUCT LIMITED WARRANTY

Kyocera Mita America, Inc. and Kyocera Mita Canada, Ltd. (both referred to as “Kyocera”) warrant the Customer’s new Multifunctional Product (referred to as “MFP”), and the new accessories installed with the initial installation of the MFP, against any defects in material and workmanship for a period of one (1) year, or 100,000 copies/prints from date of installation, whichever first occurs. In the event the MFP or an accessory is found to be defective within the warranty period, Kyocera’s only obligation and the Customer’s exclusive remedy shall be replacement of any defective parts. Kyocera shall have no obligation to furnish labor.

This warranty covers Maintenance Kits and the components of Maintenance Kits included with the original MFP for a period of three years or 100,000 copies/prints, whichever first occurs. Maintenance Kits consist of the developing unit, the drum unit, the transfer belt, and the fixing unit. Replacement Maintenance Kits have a 90 day Limited Warranty.

This warranty is valid only for the original retail purchaser (referred to as the “Customer”) of a new Kyocera MFP in the United States of America or Canada, based upon the country of purchase.

In order to obtain performance of this warranty, the Customer must immediately notify the Authorized Kyocera Dealer from whom the product was purchased. If the Kyocera Dealer is not able to provide service, write to Kyocera at the address below for the name and address of the Authorized Kyocera Dealer in your area, or check Kyocera’s website at www.kyoceramita.com/us.

This warranty does not cover MFPs or accessories which: (a) have become damaged due to operator negligence, misuse, accidents, improper storage or unusual physical or electrical stress, (b) have used parts or supplies which are not genuine Kyocera brand parts or supplies, (c) have been installed or serviced by a technician not employed by Kyocera or an Authorized Kyocera Dealer, or (d) have had the serial number modified, altered, or removed.

This warranty gives the Customer specific legal rights. The Customer may also have other rights, which vary from state to state, or province to province. Neither the seller, nor any other person, is authorized to extend the time period or expand this warranty on behalf of Kyocera.

THIS WARRANTY IS MADE IN LIEU OF ALL OTHER WARRANTIES AND CONDITIONS, EXPRESS OR IMPLIED, AND KYOCERA SPECIFICALLY DISCLAIMS ANY IMPLIED WARRANTY OR CONDITION OF MERCHANTABILITY OR FITNESS FOR A PARTICULAR PURPOSE. THIS WARRANTY SHALL NOT EXTEND TO, AND KYOCERA SHALL NOT BE LIABLE FOR, ANY INCIDENTAL OR CONSEQUENTIAL DAMAGES WHICH MAY ARISE OUT OF THE USE OF, OR INABILITY TO USE, THE MFP.

KYOCERA MITA AMERICA, INC.

225 Sand Road
Fairfield, New Jersey
07004-0008, USA

KYOCERA MITA CANADA, LTD.

6120 Kestrel Road
Mississauga, Ontario L5T 1S8
Canada

Legal Restriction on Copying/Scanning

- It may be prohibited to copy/scan copyrighted material without permission of the copyright owner.
- Copying/Scanning the following items is prohibited and may be penalized by law. It may not be limited to these items. Do not knowingly copy/scan the items that are not to be copied/scanned.
 - Paper money
 - Bank note
 - Securities
 - Stamp
 - Passport
 - Certificate
- Local laws and regulations may prohibit or restrict copying/scanning of other items not mentioned above.

Legal and Safety Information

Please read this information before using your machine. This chapter provides information on the following topics.

- Legal Information xx
- Regarding Trade Names..... xxi
- Energy Saving Control Function xxv
- Automatic 2-Sided Copy Function xxv
- Paper Recycling xxv
- Energy Star (ENERGY STAR®) Program..... xxv
- About this Operation Guide.....xxvi
- Conventions in This Guide..... xxvii

Legal Information

Copying or other reproduction of all or part of this guide without the prior written consent of Kyocera Mita Corporation is prohibited.

Regarding Trade Names

- PRESCRIBE and ECOSYS are trademarks of Kyocera Corporation.
- KPDL is a trademark of Kyocera Corporation.
- Microsoft, MS-DOS, Windows, Windows NT and Internet Explorer are registered trademarks of Microsoft Corporation in the U.S.A. and/or other countries.
- Windows Me, Windows XP and Windows Vista are trademarks of Microsoft Corporation.
- PCL is a trademark of Hewlett-Packard Company.
- Adobe Acrobat, Adobe Reader and PostScript are trademarks of Adobe Systems, Incorporated.
- Ethernet is a registered trademark of Xerox Corporation.
- Novell and NetWare are registered trademarks of Novell, Inc.
- IBM and IBM PC/AT are trademarks of International Business Machines Corporation.
- Power PC is a trademark of IBM in the U.S.A. and/or other countries.
- AppleTalk is a registered trademark of Apple Computer, Inc.
- This machine has been developed using embedded real-time operating system Tornado™ by Wind River Systems, Inc.
- TrueType is a registered trademark of Apple Computer, Inc.
- TypeBankG-B, TypeBankM-M and Typebank-OCR are trademarks of TypeBank®.
- All European language fonts installed in this machine are used under licensing agreement with Monotype Imaging Inc.
- Helvetica, Palatino and Times are registered trademarks of Linotype-Hell AG.
- ITC Avant Garde Gothic, ITC Bookman, ITC ZapfChancery and ITC ZapfDingbats are registered trademarks of International Type-face Corporation.
- UFST™ MicroType® fonts by Monotype Imaging Inc. are installed in this machine.
- This machine contains the software having modules developed by Independent JPEG Group.

All other brands and product names are registered trademarks or trademarks of their respective companies. The designations ™ and ® will not be used in this Operation Guide.

GPL

Firmware of this machine is using in part the GPL applied codes (www.fsf.org/copyleft/gpl.html). Please access "<http://www.kyoceramita.com/gpl>" for more information on how to make GPL applied codes available.

Open SSLeay License

Copyright (c) 1998-2006 The OpenSSL Project. All rights reserved.

Redistribution and use in source and binary forms, with or without modification, are permitted provided that the following conditions are met:

- 1 Redistributions of source code must retain the above copyright notice, this list of conditions and the following disclaimer.
- 2 Redistributions in binary form must reproduce the above copyright notice, this list of conditions and the following disclaimer in the documentation and/or other materials provided with the distribution.
- 3 All advertising materials mentioning features or use of this software must display the following acknowledgment:
"This product includes software developed by the OpenSSL Project for use in the OpenSSL Toolkit. (<http://www.openssl.org/>)"
- 4 The names "OpenSSL Toolkit" and "OpenSSL Project" must not be used to endorse or promote products derived from this software without prior written permission.
For written permission, please contact openssl-core@openssl.org.
- 5 Products derived from this software may not be called "OpenSSL" nor may "OpenSSL" appear in their names without prior written permission of the OpenSSL Project.
- 6 Redistributions of any form whatsoever must retain the following acknowledgment: "This product includes software developed by the OpenSSL Project for use in the OpenSSL Toolkit (<http://www.openssl.org/>)"

THIS SOFTWARE IS PROVIDED BY THE OpenSSL PROJECT "AS IS" AND ANY EXPRESSED OR IMPLIED WARRANTIES, INCLUDING, BUT NOT LIMITED TO, THE

IMPLIED WARRANTIES OF MERCHANTABILITY AND FITNESS FOR A PARTICULAR PURPOSE ARE DISCLAIMED. IN NO EVENT SHALL THE OpenSSL PROJECT OR ITS CONTRIBUTORS BE LIABLE FOR ANY DIRECT, INDIRECT, INCIDENTAL, SPECIAL, EXEMPLARY, OR CONSEQUENTIAL DAMAGES (INCLUDING, BUT NOT LIMITED TO, PROCUREMENT OF SUBSTITUTE GOODS OR SERVICES; LOSS OF USE, DATA, OR PROFITS; OR BUSINESS INTERRUPTION) HOWEVER CAUSED AND ON ANY THEORY OF LIABILITY, WHETHER IN CONTRACT, STRICT LIABILITY, OR TORT (INCLUDING NEGLIGENCE OR OTHERWISE) ARISING IN ANY WAY OUT OF THE USE OF THIS SOFTWARE, EVEN IF ADVISED OF THE POSSIBILITY OF SUCH DAMAGE.

Original SSLeay License

Copyright (C) 1995-1998 Eric Young (eay@cryptsoft.com) All rights reserved.

This package is an SSL implementation written by Eric Young (eay@cryptsoft.com). The implementation was written so as to conform with Netscapes SSL.

This library is free for commercial and non-commercial use as long as the following conditions are aheared to. The following conditions apply to all code found in this distribution, be it the RC4, RSA, lhash, DES, etc., code; not just the SSL code. The SSL documentation included with this distribution is covered by the same copyright terms except that the holder is Tim Hudson (tjh@cryptsoft.com).

Copyright remains Eric Young's, and as such any Copyright notices in the code are not to be removed.

If this package is used in a product, Eric Young should be given attribution as the author of the parts of the library used.

This can be in the form of a textual message at program startup or in documentation (online or textual) provided with the package.

Redistribution and use in source and binary forms, with or without modification, are permitted provided that the following conditions are met:

- 1** Redistributions of source code must retain the copyright notice, this list of conditions and the following disclaimer.
- 2** Redistributions in binary form must reproduce the above copyright notice, this list of conditions and the following disclaimer in the documentation and/or other materials provided with the distribution.
- 3** All advertising materials mentioning features or use of this software must display the following acknowledgement:
"This product includes cryptographic software written by Eric Young (eay@cryptsoft.com)"
The word 'cryptographic' can be left out if the rouines from the library being used are not cryptographic related :-).
- 4** If you include any Windows specific code (or a derivative thereof) from the apps directory (application code) you must include an acknowledgement:
"This product includes software written by Tim Hudson (tjh@cryptsoft.com)"

THIS SOFTWARE IS PROVIDED BY ERIC YOUNG "AS IS" AND ANY EXPRESS OR IMPLIED WARRANTIES, INCLUDING, BUT NOT LIMITED TO, THE IMPLIED WARRANTIES OF MERCHANTABILITY AND FITNESS FOR A PARTICULAR PURPOSE ARE DISCLAIMED. IN NO EVENT SHALL THE AUTHOR OR CONTRIBUTORS BE LIABLE FOR ANY DIRECT, INDIRECT, INCIDENTAL, SPECIAL, EXEMPLARY, OR CONSEQUENTIAL DAMAGES (INCLUDING, BUT NOT LIMITED TO, PROCUREMENT OF SUBSTITUTE GOODS OR SERVICES; LOSS OF USE, DATA, OR PROFITS; OR BUSINESS INTERRUPTION) HOWEVER CAUSED AND ON ANY THEORY OF LIABILITY, WHETHER IN CONTRACT, STRICT LIABILITY, OR TORT (INCLUDING NEGLIGENCE OR OTHERWISE) ARISING IN ANY WAY OUT OF THE USE OF THIS SOFTWARE, EVEN IF ADVISED OF THE POSSIBILITY OF SUCH DAMAGE.

The licence and distribution terms for any publically available version or derivative of this code cannot be changed. i.e. this code cannot simply be copied and put under another distribution licence [including the GNU Public Licence.]

Monotype Imaging License Agreement

- 1** *Software* shall mean the digitally encoded, machine readable, scalable outline data as encoded in a special format as well as the UFST Software.
- 2** You agree to accept a non-exclusive license to use the Software to reproduce and display weights, styles and versions of letters, numerals, characters and symbols (*Typefaces*) solely for your own customary business or personal purposes at the address stated on the registration card you return to Monotype Imaging. Under the terms of this License Agreement, you have the right to use the Fonts on up to three printers. If you need to have access to the fonts on more than three printers, you need to acquire a multi-user license agreement which can be obtained from Monotype Imaging. Monotype Imaging retains all rights, title and interest to the Software and Typefaces and no rights are granted to you other than a License to use the Software on the terms expressly set forth in this Agreement.
- 3** To protect proprietary rights of Monotype Imaging, you agree to maintain the Software and other proprietary information concerning the Typefaces in strict confidence and to establish reasonable procedures regulating access to and use of the Software and Typefaces.
- 4** You agree not to duplicate or copy the Software or Typefaces, except that you may make one backup copy. You agree that any such copy shall contain the same proprietary notices as those appearing on the original.
- 5** This License shall continue until the last use of the Software and Typefaces, unless sooner terminated. This License may be terminated by Monotype Imaging if you fail to comply with the terms of this License and such failure is not remedied within thirty (30) days after notice from Monotype Imaging. When this License expires or is terminated, you shall either return to Monotype Imaging or destroy all copies of the Software and Typefaces and documentation as requested.
- 6** You agree that you will not modify, alter, disassemble, decrypt, reverse engineer or decompile the Software.
- 7** Monotype Imaging warrants that for ninety (90) days after delivery, the Software will perform in accordance with Monotype Imaging-published specifications, and the diskette will be free from defects in material and workmanship. Monotype Imaging does not warrant that the Software is free from all bugs, errors and omissions.

The parties agree that all other warranties, expressed or implied, including warranties of fitness for a particular purpose and merchantability, are excluded.
- 8** Your exclusive remedy and the sole liability of Monotype Imaging in connection with the Software and Typefaces is repair or replacement of defective parts, upon their return to Monotype Imaging.

In no event will Monotype Imaging be liable for lost profits, lost data, or any other incidental or consequential damages, or any damages caused by abuse or misapplication of the Software and Typefaces.
- 9** Massachusetts U.S.A. law governs this Agreement.
- 10** You shall not sublicense, sell, lease, or otherwise transfer the Software and/or Typefaces without the prior written consent of Monotype Imaging.
- 11** Use, duplication or disclosure by the Government is subject to restrictions as set forth in the Rights in Technical Data and Computer Software clause at FAR 252-227-7013, subdivision (b)(3)(ii) or subparagraph (c)(1)(ii), as appropriate. Further use, duplication or disclosure is subject to restrictions applicable to restricted rights software as set forth in FAR 52.227-19 (c)(2).
- 12** You acknowledge that you have read this Agreement, understand it, and agree to be bound by its terms and conditions. Neither party shall be bound by any statement or representation not contained in this Agreement. No change in this Agreement is effective unless written and signed by properly authorized representatives of each party. By opening this diskette package, you agree to accept the terms and conditions of this Agreement.

Energy Saving Control Function

The device comes equipped with a **Low Power Mode** where energy consumption is reduced after a certain amount of time elapses since the device was last used, as well as a **Sleep Mode** where printer and fax functions remain in a waiting state but power consumption is still reduced to a minimum when there is no activity with the device within a set amount of time.

Low Power Mode

The device automatically enters Low Power Mode when 2 minutes have passed since the device was last used. The amount of time of no activity that must pass before Low Power Mode is activated may be lengthened. For more information refer to *Auto Low Power Mode on page 3-4*.

Sleep

The device automatically enters Sleep when 15 minutes have passed since the device was last used. The amount of time of no activity that must pass before Sleep is activated may be lengthened. For more information see *Sleep and Auto Sleep on page 3-5*.

Automatic 2-Sided Copy Function

This device includes 2-sided copying as a standard function. For example, by copying two 1-sided originals onto a single sheet of paper as a 2-sided copy, it is possible to lower the amount of paper used. For more information see *Duplex Copying on page 3-14*.

Paper Recycling

This device supports the recycled paper which reduces the load on the environment. Your sales or service representative can provide information about recommended paper types.

Energy Star (ENERGY STAR®) Program



We have determined as a participating company in the International Energy Star Program that this product is compliant with the standards laid out in the International Energy Star Program.

About this Operation Guide

This Operation Guide contains the following chapters.

Chapter 1 - Part Names

Identifies machine parts and operation panel keys.

Chapter 2 - Preparation before Use

Explains adding paper, placing originals, connecting the machine, and necessary configurations before first use.

Chapter 3 - Basic Operation

Describes the procedures for basic copying, printing and scanning.

Chapter 4 - Copying Functions

Describes the functions you can use when copying.

Chapter 5 - Sending Functions

Describes the functions you can use when sending originals.

Chapter 6 - Document Box

Provides a basic guide to using document boxes.

Chapter 7 - Status / Job Cancel

Explains how to check the job status and job history and how to cancel jobs being printed or waiting to print. Also explains how to check the remaining paper and device status and how to cancel fax transmission

Chapter 8 - Default Setting (System Menu)

Describes the System Menu options for general machine operation.

Chapter 9 - Maintenance

Describes cleaning and toner replacement.

Chapter 10 - Troubleshooting

Explains how to handle error messages, paper jams and other problems.

Chapter 11 - Management

Explains user login administration and job accounting. Also describes the procedure for Data Security Kit installation.

Appendix

Explains how to enter characters, and lists the machine specifications. Introduces the convenient optional equipment available for this machine. Provides information on media types and paper sizes. Also includes a glossary of terms.

Conventions in This Guide

The following conventions are used depending on the nature of the description.

Convention	Description	Example
Bold	Indicates the operation panel keys or a computer screen.	Press the Start key.
[Regular]	Indicates a selection item on the Message Display.	Select [System].
<i>Italic</i>	Indicates a message displayed on the Message Display.	<i>Ready to copy</i> is displayed.
	Used to emphasize a key word, phrase or references to additional information.	For more information refer to <i>Sleep and Auto Sleep on page 3-5</i> .
Note	Indicates supplemental information or operations for reference.	NOTE:
Important	Indicates items that are required or prohibited so as to avoid problems.	IMPORTANT:
Caution	Indicates what must be observed to prevent injury or machine breakdown and how to deal with it.	CAUTION:

1 Part Names

This chapter identifies the machine parts and operation panel keys.

- Operation Panel 1-2
- Machine 1-4

Operation Panel

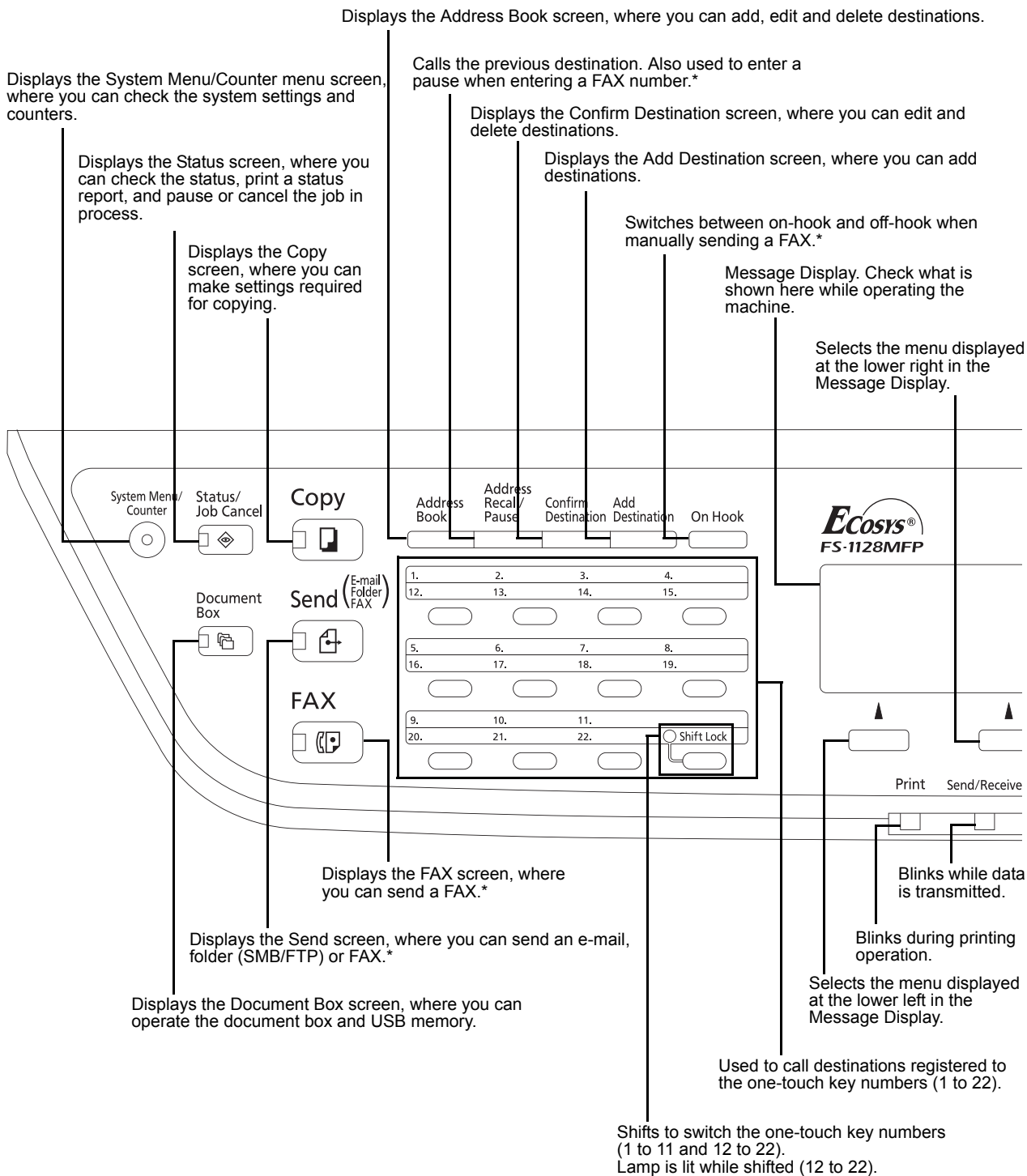

* FAX functions available only in FS-1128MFP.

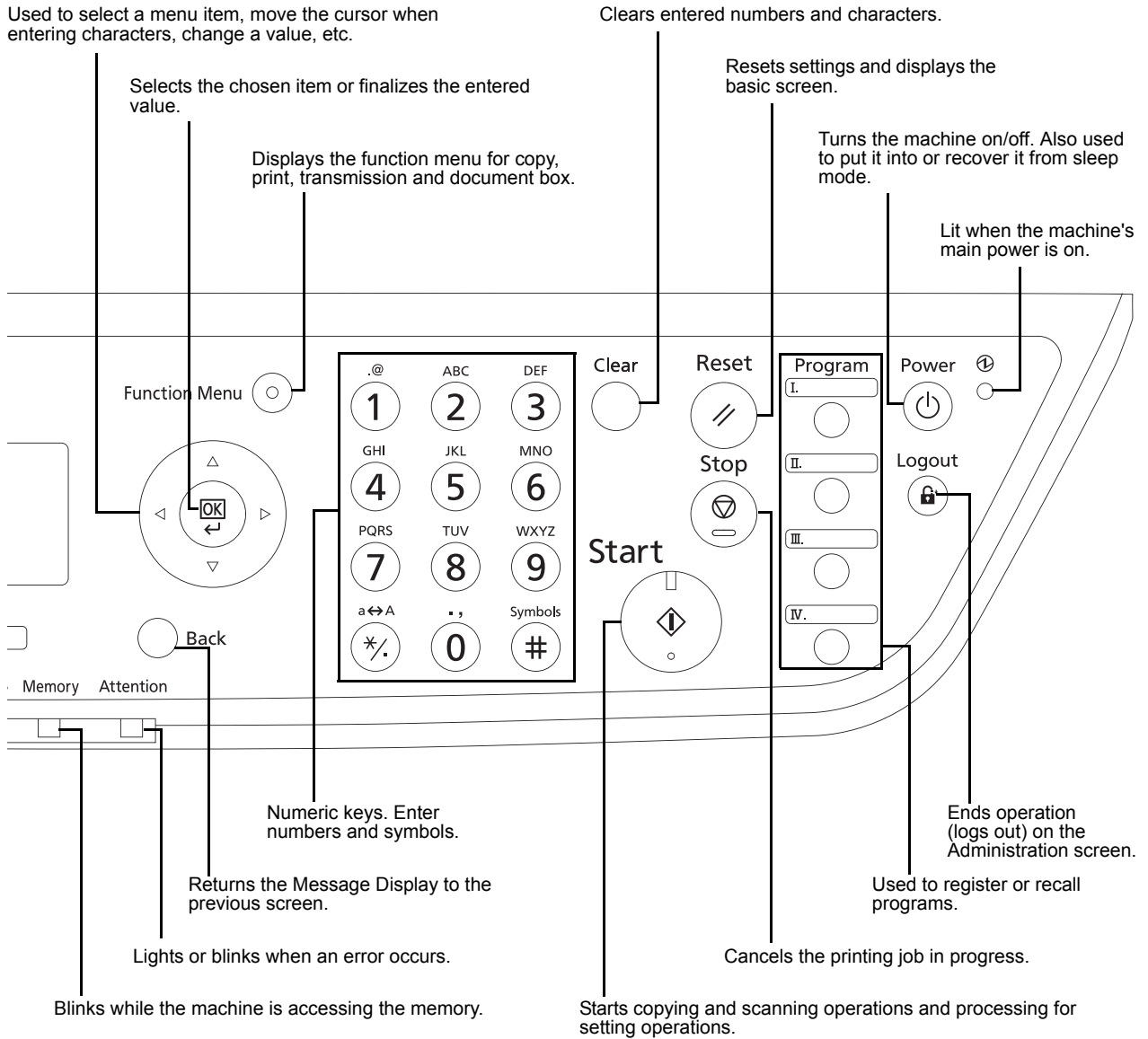

Machine

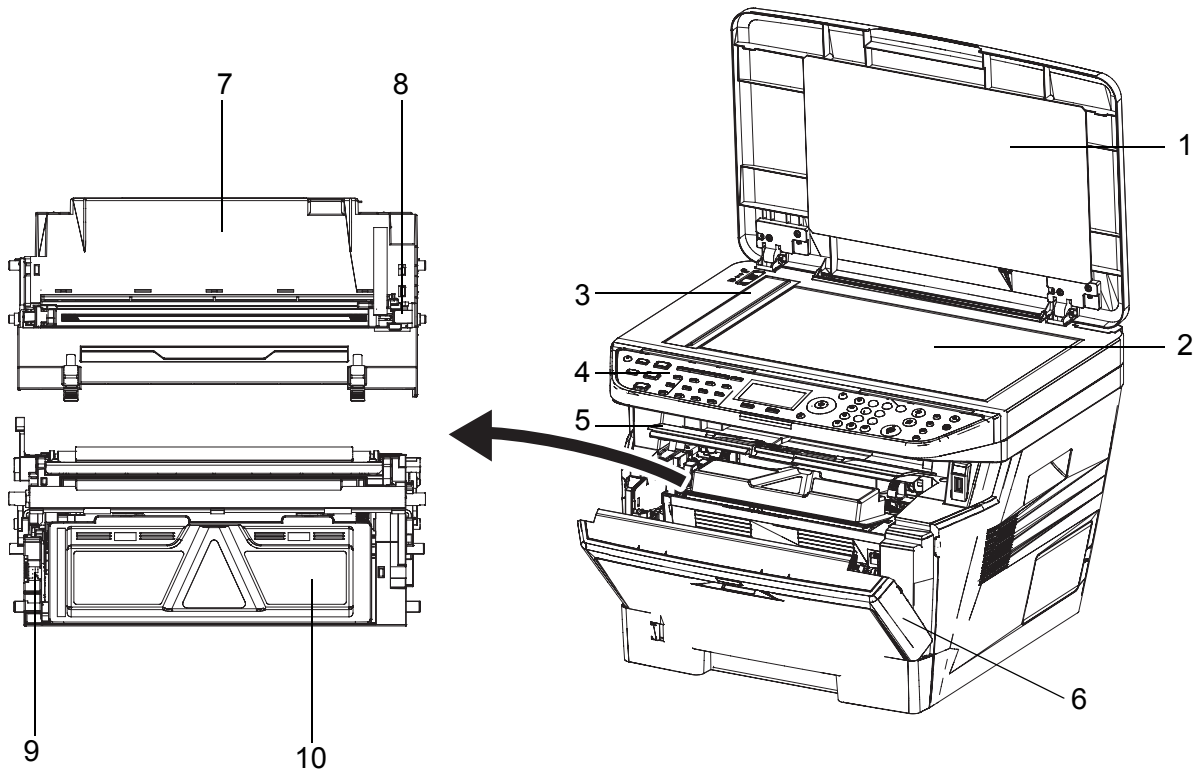

- 1** Original Cover (For FS-1028MFP only)
- 2** Platen
- 3** Original Size Indicator Plate
- 4** Operation Panel
- 5** Top Cover
- 6** Front Cover
- 7** Drum Unit
- 8** Main Charger Cleaner
- 9** Lock Lever
- 10** Toner Container

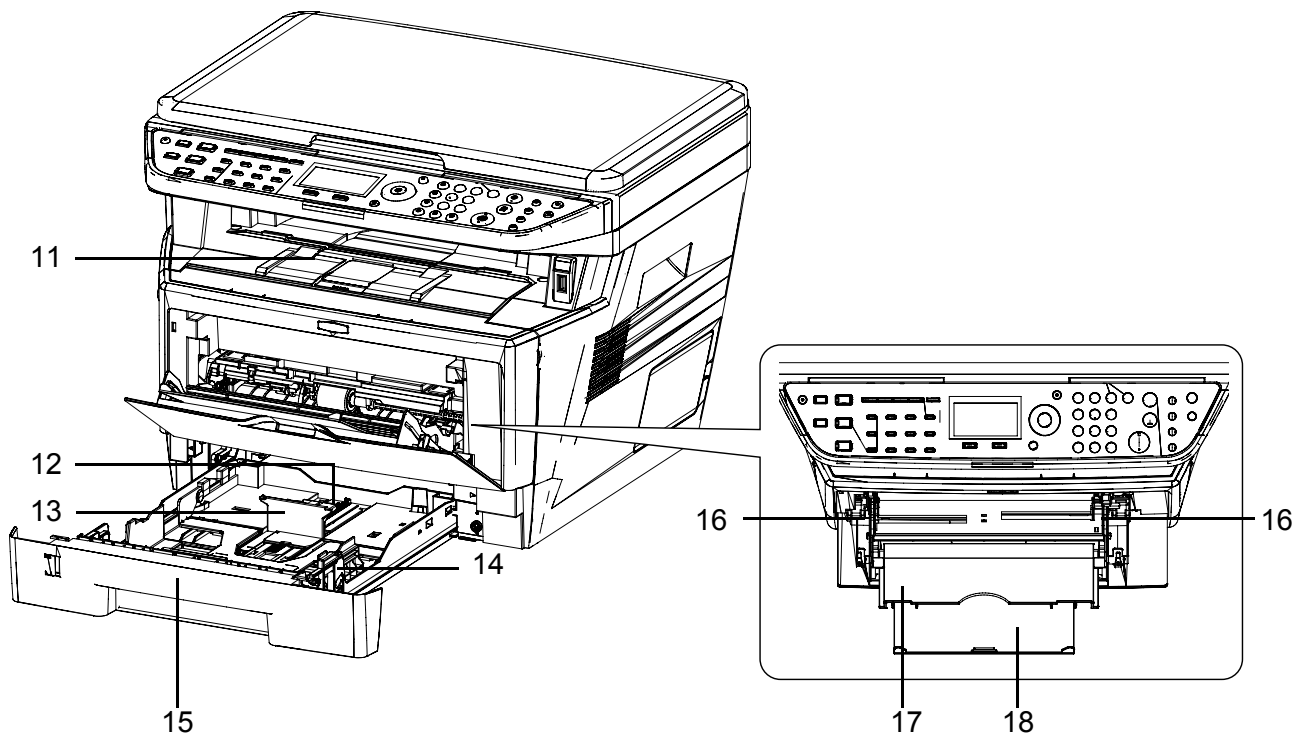

- 11** Top Tray
- 12** Paper Length Guide
- 13** Paper Stopper
- 14** Paper Width Guides
- 15** Cassette
- 16** Paper Width Guides (MP Tray)
- 17** MP (Multi-Purpose) Tray
- 18** MP Tray Extension

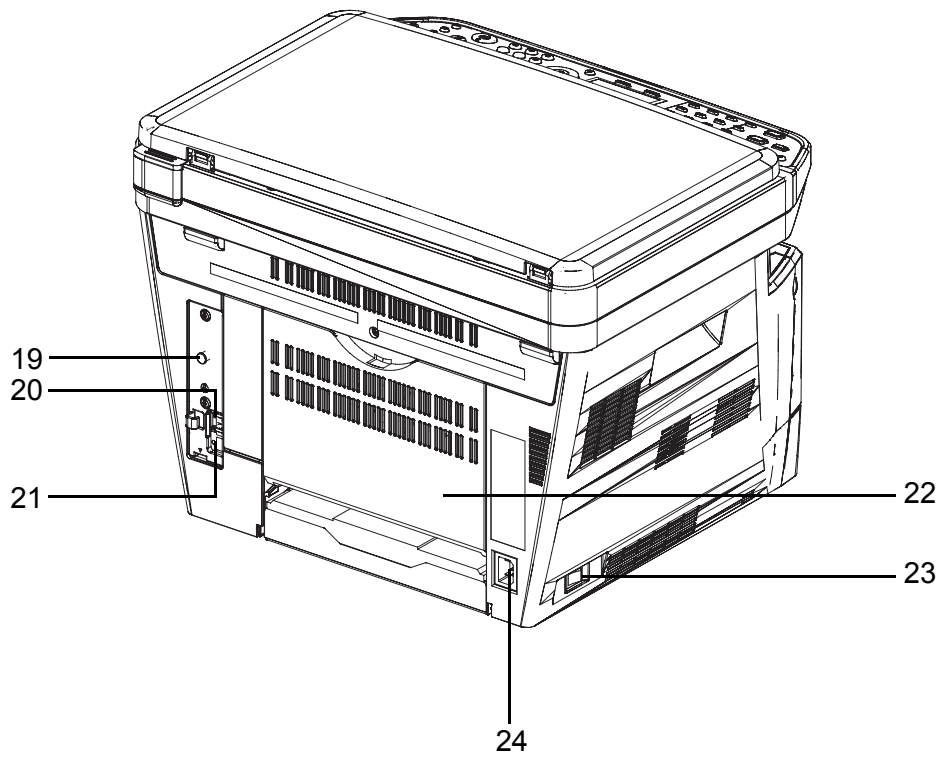

- 19** Anchor Pin
- 20** USB Interface Connector
- 21** Network Interface Connector
- 22** Rear Cover
- 23** Main Power Switch
- 24** Power Cord Connector

2 Preparation before Use

This chapter explains the preparations before using this equipment for the first time as well as the procedures for loading papers and originals.

- Check bundled items2-2
- Determining the Connection Method and Preparing Cables.....2-3
- Connecting Cables.....2-5
- Switching the Language for Display [Language].....2-7
- Setting Date and Time2-9
- Network Setup (LAN Cable Connection)2-12
- Installing Software.....2-24
- COMMAND CENTER (Settings for E-mail)2-25
- Sending E-mail.....2-26
- Loading Paper.....2-28
- Loading Originals.....2-44

Check bundled items

Check that the following items have been bundled.

- Printed material
- CD-ROM(Product Library)
- CD-ROM(TWAIN compatible application)

Documents Contained in the Included CD-ROM

The following documents are contained in the included CD-ROM (Product Library). Refer to them as necessary.

Documents

KYOCERA COMMAND CENTER Operation Guide

Printer Driver User Guide

Network FAX Driver Operation Guide

KM-NET for Direct Printing Operation Guide

PRESCRIBE Commands Technical Reference

PRESCRIBE Commands Command Reference

Determining the Connection Method and Preparing Cables

Check the method to connect the equipment to a PC or network, and prepare the necessary cables.

Connection Example

Determine the method to connect the equipment to a PC or network by referring to the illustration below.

Connecting a scanner to your PC network with a network cable (100BASE-TX or 10BASE-T)

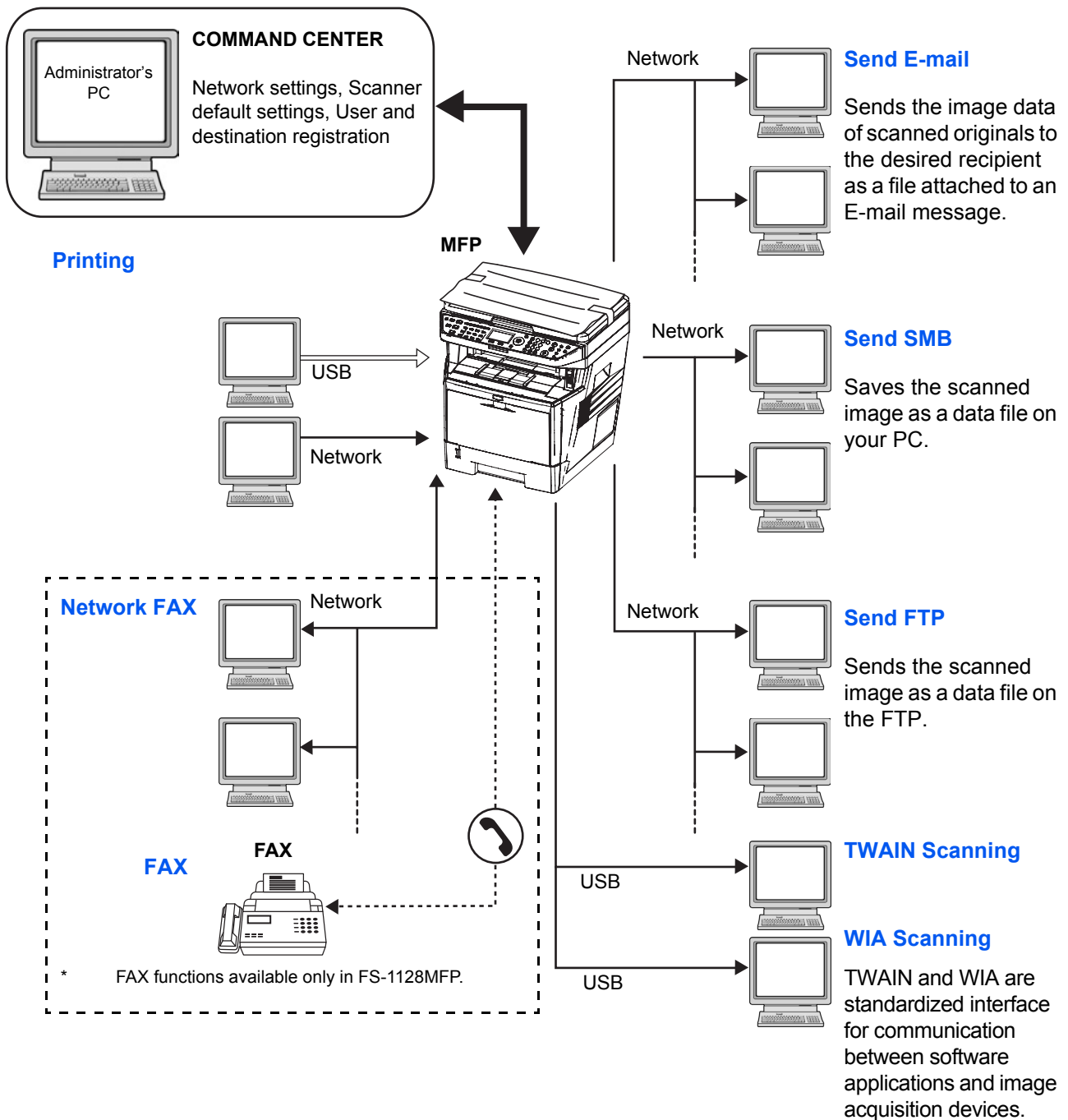

Preparing Necessary Cables

The following interfaces are available to connect the equipment to a PC. Prepare the necessary cables according to the interface you use.

Available Standard Interfaces

Function	Interface	Necessary Cable
Printer/Scanner /Network FAX*	Network interface	LAN (10Base-T or 100Base-TX, Shielded)
Printer/TWAIN Scanning/WIA Scanning	USB interface	USB2.0 compatible cable (Hi-Speed USB compliant, Max. 5.0 m, Shielded)

* Network FAX and FAX functions available only in FS-1128MFP. For details on Network FAX, refer to the *FAX Operation Guide*.

Connecting Cables

Follow the steps below to connect cables to the machine.

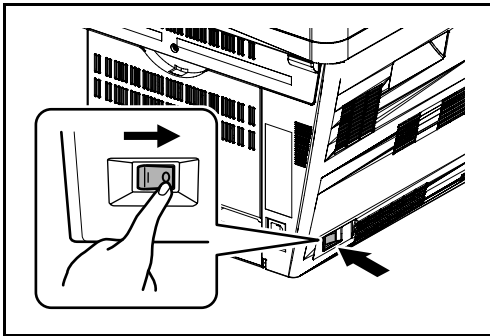

- 1 Turn the main power switch off (O).

2

- 2 Connect the machine to the PC or your network device. When using the network interface, remove the cap..

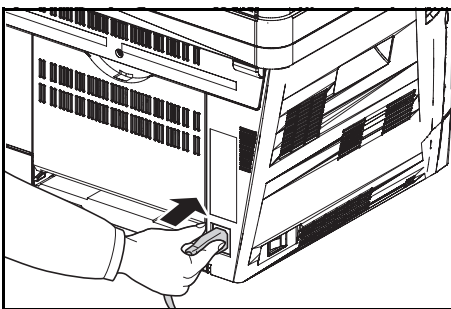
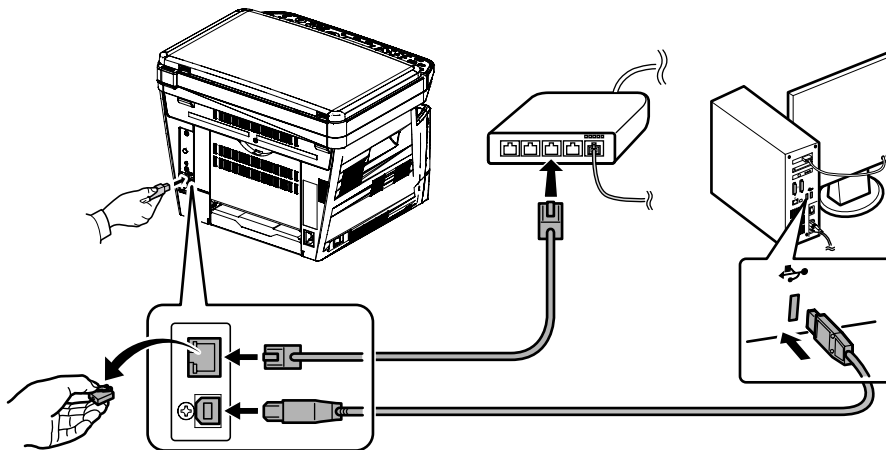

- 3 Connect one end of the supplied power cable to the machine and the other end to a power outlet.

IMPORTANT: Only use the power cable that comes with the machine.

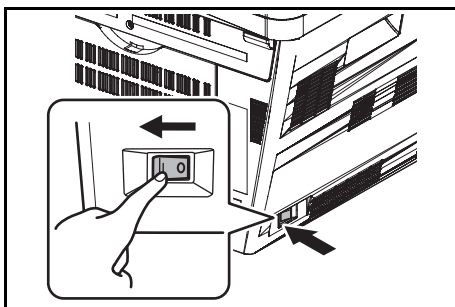

4 Turn the main power switch on (I). The machine begins to warm up.

5 When connecting the network cable, configure the network. For details, refer to *Network Setup (LAN Cable Connection)* on page 2-12.

Switching the Language for Display [Language]

Select the language displayed on the Message Display.

Use the procedure below to select the language.

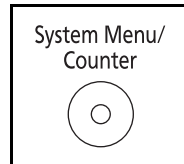

- 1 Press the **System Menu/Counter** key on the main unit operation panel.

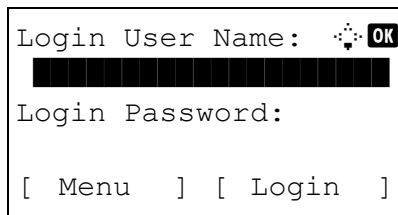

When you are performing user management and have not logged in, a login screen will appear. Then, enter the user ID and password to log in.

NOTE:

- Refer to *Character Entry Method on Appendix-5* for details on entering characters.
- If [Netwk Authentic.] is selected as the user authentication method, press [Menu] (the **Left Select** key) to select the authentication destination.

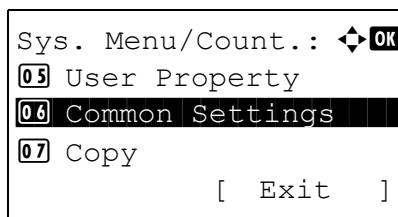

- 2 In the Sys. Menu/Count. menu, press the Δ or ∇ key to select [Common Settings].

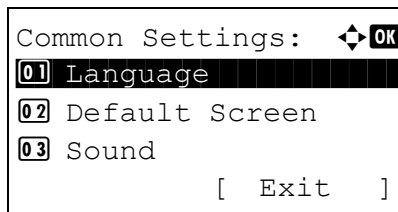

- 3 Press the **OK** key. The Common Settings menu appears.

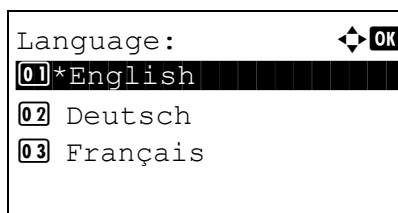

- 4 Press the Δ or ∇ key to select [Language].

- 5 Press the **OK** key. Language appears.

- 6 Press the Δ or ∇ key to select the desired language and then press the **OK** key.

Completed. is displayed and the screen returns to the Common Settings menu.

Setting Date and Time

Follow the steps below to set the local date and time at the place of installation.

When you send an E-mail using the transmission function, the date and time as set here will be printed in the header of the E-mail message. Set the date, time and time difference from GMT of the region where the machine is used.

2

NOTE: Be sure to set the time difference before setting the date and time.

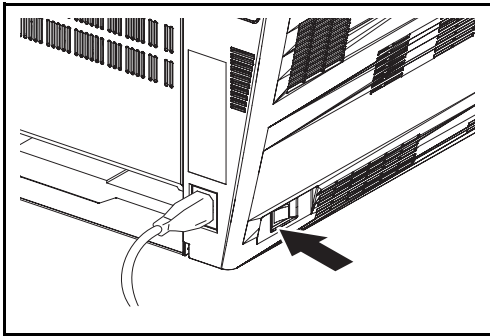

1 Turn on the main power switch.

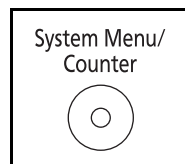

2 Press the **System Menu/Counter** key on the main unit operation panel.

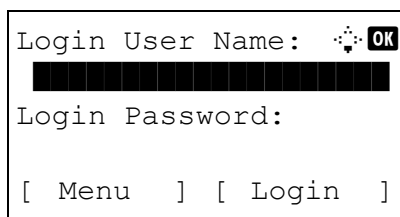

When you are performing user management and have not logged in, a login screen will appear. Then, enter the user ID and password to log in.

NOTE: If [Netwk Authentic.] is selected as the user authentication method, press [Menu] (the **Left Select** key) to select the authentication destination.

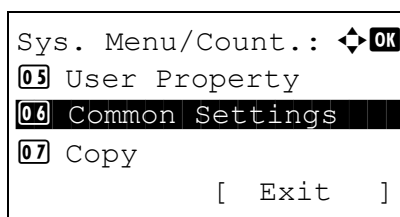

3 In the Sys. Menu/Count. menu, press the Δ or ∇ key to select [Common Settings].

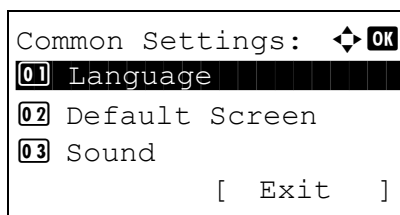

4 Press the **OK** key. The Common Settings menu appears.

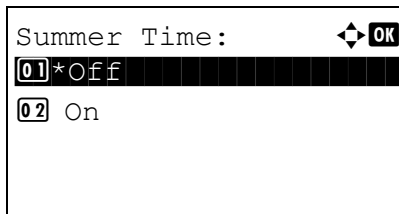
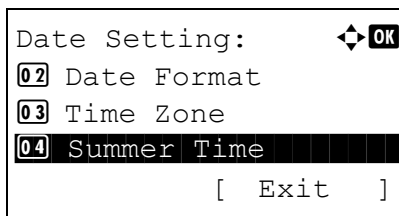
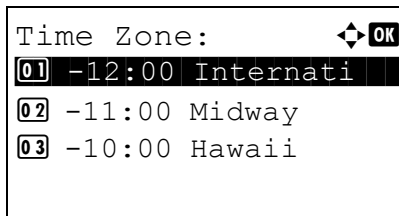
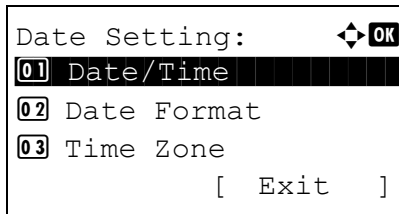
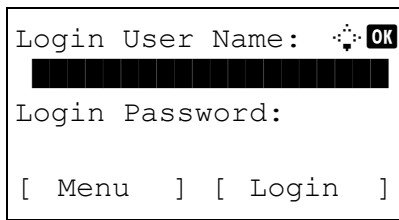

- 5 Press the Δ or ∇ key to select [Date Setting].
- 6 A login screen will appear. Then, enter the user ID and password to log in.
- 7 Press the **OK** key. The Date Setting menu appears.
- 8 Press the Δ or ∇ key to select [Time Zone].
- 9 Press the **OK** key. Time Zone appears.
- 10 Press the Δ or ∇ key to select your region and then press the **OK** key.
Completed. is displayed and the screen returns to the Date Setting menu.
- 11 Press the Δ or ∇ key to select [Summer Time].
- 12 Press the **OK** key. Summer Time appears.
- 13 Press the Δ or ∇ key to select [On] or [Off] and then press the **OK** key.

```

Date Setting: ⏏ OK
01 Date/Time
02 Date Format
03 Time Zone
      [ Exit ]

```

- 14 Press the Δ or ∇ key to select [Date/Time].

```

Date/Time: ⏏ OK
Year  Month  Day
2009    01    01
(Time Zone:Tokyo )

```

- 15 Press the **OK** key. Date/Time appears.

```

Date/Time: ⏏ OK
Hour  Min.  Second
    11:   45:   50
(Time Zone:Tokyo )

```

- 16 Press the \triangleleft or \triangleright key to move the cursor position, press the Δ or ∇ key to enter year, month and day, and then press the **OK** key.

- 17 Press the \triangleleft or \triangleright key to move the cursor position, press the Δ or ∇ key to enter hours, minutes and seconds, and then press the **OK** key.

Completed. is displayed and the screen returns to the Date Setting menu.

```

Date Setting: ⏏ OK
01 Date/Time
02 Date Format
03 Time Zone
      [ Exit ]

```

- 18 Press the Δ or ∇ key to select [Date Format].

```

Date Format: ⏏ OK
01 *Month/Day/Year
02 Day/Month/Year
03 Year/Month/Day

```

- 19 Press the **OK** key. Date Format appears.

- 20 Press the Δ or ∇ key to select the desired display format and then press the **OK** key.

Completed. is displayed and the screen returns to the Date Setting menu.

Network Setup (LAN Cable Connection)

The machine is equipped with network interface, which is compatible with network protocols such as TCP/IP (IPv4), TCP/IP (IPv6), IPX/SPX, NetBEUI, IPsec, and AppleTalk. It enables network printing on the Windows, Macintosh, UNIX, NetWare and other platforms.

This section explains the *TCP/IP (IPv4) Setup* and *AppleTalk Setup* procedures. For other network settings, refer to *Network Setup on page 8-128*.

- TCP/IP (IPv4) Setup ...2-12
- AppleTalk Setup ...2-22

TCP/IP (IPv4) Setup (by Entering IP Addresses)

Set up TCP/IP to connect to the Windows network. Set the IP addresses, subnet masks, and gateway addresses. The default settings are "TCP/IP Protocol: On, DHCP: On, Bonjour: Off".

NOTE: Prior to the IP address entries, obtain permission from the network administrator.

Use the procedure below to setup the TCP/IP (IPv4) setting.

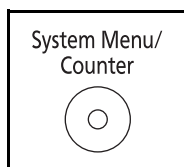

- 1 Press the **System Menu/Counter** key on the main unit operation panel.

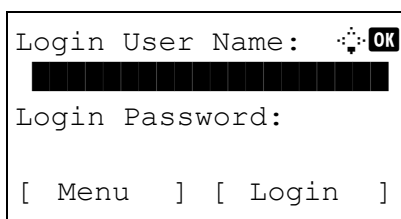

When you are performing user management and have not logged in, a login screen will appear. Then, enter the user ID and password to log in.

NOTE:

- Refer to *Character Entry Method on Appendix-5* for details on entering characters.
- If [Netwk Authentic.] is selected as the user authentication method, press [Menu] (the **Left Select** key) to select the authentication destination.

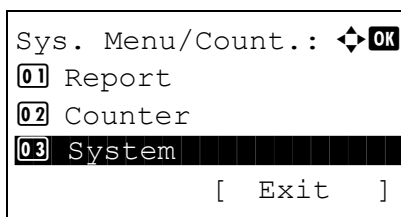

- 2 In the Sys. Menu/Count. menu, press the Δ or ∇ key to select [System], and then press the **OK** key.

```
Administrator only.
```

```
System: ⬆️ OK
01 Network Setting
02 I/F Block Set.
03 Security Level
      [ Exit ]
```

```
Network Setting: ⬆️ OK
01 TCP/IP Settings
02 NetWare
03 AppleTalk
      [ Exit ]
```

```
TCP/IP Settings: ⬆️ OK
01 TCP/IP
02 IPv4 Setting
03 IPv6 Setting
      [ Exit ]
```

```
TCP/IP: ⬆️ OK
01 Off
02 *On
```

IMPORTANT: To make the settings, you must have logged in using a user ID with administrator privileges. The default settings of the login user name and login password are both 2800.

If you have logged in using a user ID without administrator privileges, the screen will display *Administrator only.* and return to the standby screen.

3 In the System menu, press the Δ or ∇ key to select [Network Setting].

4 Press the **OK** key. The Network Setting menu appears.

5 Press the Δ or ∇ key to select [TCP/IP Settings].

6 Press the **OK** key. The TCP/IP Settings menu appears.

7 Press the Δ or ∇ key to select [TCP/IP].

8 Press the **OK** key. TCP/IP appears.

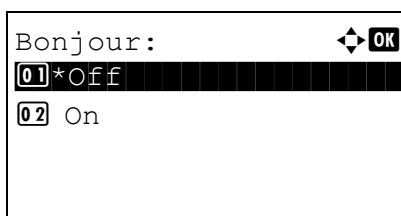
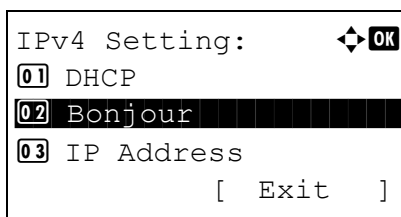
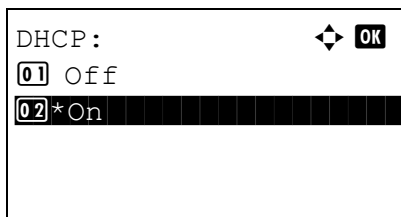
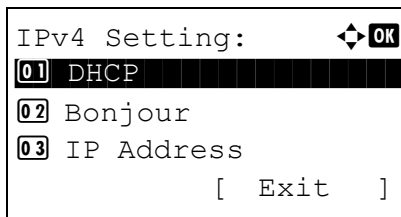
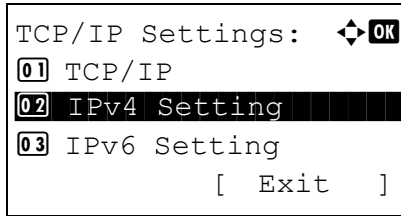

9 Press the Δ or ∇ key to select [On] and then press the **OK** key.

Completed. is displayed and the screen returns to the TCP/IP Settings menu.

10 Press the Δ or ∇ key to select [IPv4 Setting].

11 Press the **OK** key. The IPv4 Setting menu appears.

12 Press the Δ or ∇ key to select [DHCP].

13 Press the **OK** key. DHCP appears.

14 Press the Δ or ∇ key to select [Off] and then press the **OK** key.

Completed. is displayed and the screen returns to the IPv4 Setting menu.

15 Press the Δ or ∇ key to select [Bonjour].

16 Press the **OK** key. Bonjour appears.

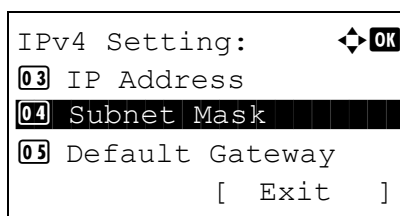
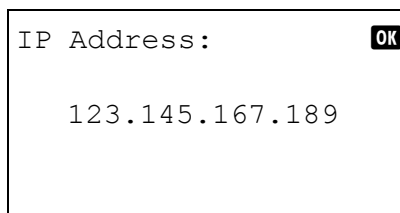
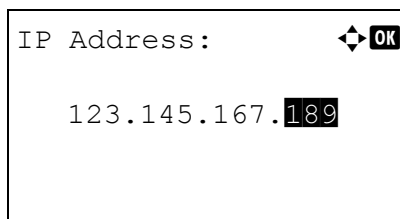
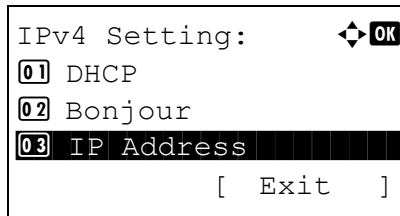

- 17 Press the Δ or ∇ key to select [Off] and then press the **OK** key.

Completed. is displayed and the screen returns to the IPv4 Setting menu.

- 18 Press the Δ or ∇ key to select [IP Address].

- 19 Press the **OK** key. IP Address appears.

- 20 Use the arrow keys to enter the IP address.

Press the \triangleleft or \triangleright key to move the cursor position horizontally.

Press the Δ or ∇ key or the numeric keys to enter the IP Address. Each 3 digits can be set between 000 and 255.

IMPORTANT: When the DHCP Setting (*page 2-18*) is [On], the current IP address is displayed and cannot be changed.

When setting an IP address, set the DHCP Setting (*page 2-18*) to Off.

- 21 Press the **OK** key. *Completed.* is displayed and the screen returns to the IPv4 Setting menu.

- 22 Press the Δ or ∇ key to select [Subnet Mask].

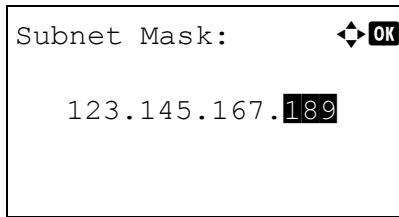

23 Press the **OK** key. Subnet Mask appears.

24 Use the arrow keys to enter the Subnet Mask.

Press the ◀ or ▶ key to move the cursor position horizontally.

Press the ▲ or ▼ key or the numeric keys to enter the Subnet Mask. Each 3 digits can be set between 000 and 255.

IMPORTANT: When the DHCP Setting (*page 2-18*) is [On], the current Subnet Mask is displayed and cannot be changed.

When setting an Subnet Mask, set the DHCP Setting (*page 2-18*) to Off.

25 Press the **OK** key. *Completed.* is displayed and the screen returns to the IPv4 Setting menu.

26 Press the ▲ or ▼ key to select [Default Gateway].

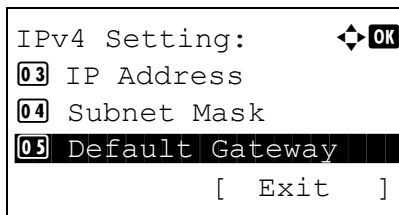

27 Press the **OK** key. Default Gateway appears.

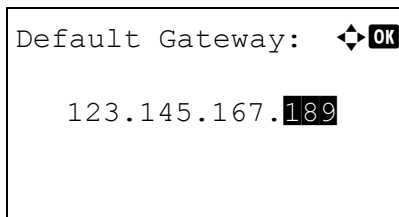

28 Use the arrow keys to enter the Default Gateway.

Press the ◀ or ▶ key to move the cursor position horizontally.

Press the ▲ or ▼ key or the numeric keys to enter the Default Gateway. Each 3 digits can be set between 000 and 255.

IMPORTANT: When the DHCP Setting (page 2-18) is [On], the current Default Gateway is displayed and cannot be changed.

When setting an Default Gateway, set the DHCP Setting (page 2-18) to Off.

29 Press the **OK** key. *Completed.* is displayed and the screen returns to the IPv4 Setting menu.

DHCP Settings

Select whether or not to use the DHCP server. The default setting is *On*.

Use the procedure below to specify the DHCP setting.

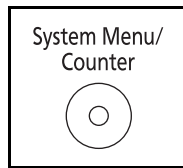

- 1 Press the **System Menu/Counter** key on the main unit operation panel.

When you are performing user management and have not logged in, a login screen will appear. Then, enter the user ID and password to log in.

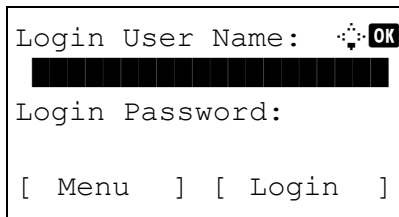

NOTE:

- Refer to *Character Entry Method on Appendix-5* for details on entering characters.
- If [Netwk Authentic.] is selected as the user authentication method, press [Menu] (the **Left Select** key) to select the authentication destination.

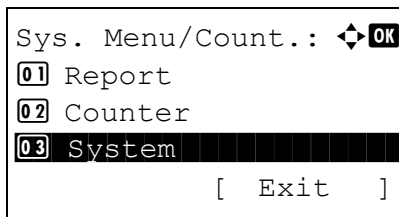

- 2 In the Sys. Menu/Count. menu, press the Δ or ∇ key to select [System], and then press the **OK** key.

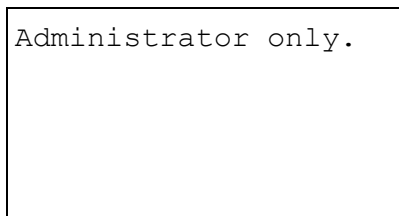

IMPORTANT: To make the settings, you must have logged in using a user ID with administrator privileges.

If you have logged in using a user ID without administrator privileges, the screen will display *Administrator only.* and return to the standby screen.

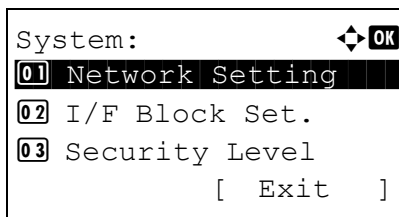

- 3 In the System menu, press the Δ or ∇ key to select [Network Setting].

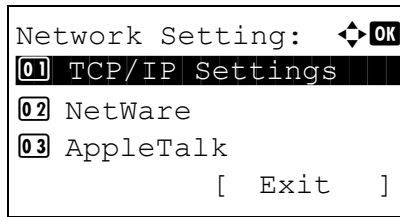

- 4 Press the **OK** key. The Network Setting menu appears.

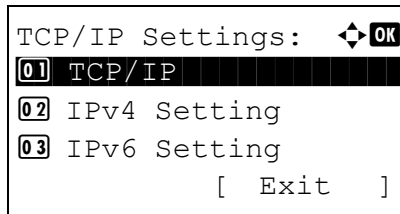

- 5 Press the Δ or ∇ key to select [TCP/IP Settings].
- 6 Press the **OK** key. The TCP/IP Settings menu appears.

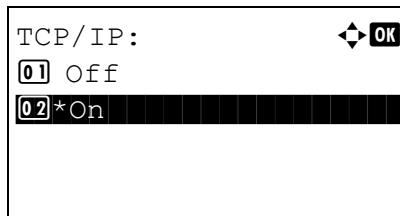

- 7 Press the Δ or ∇ key to select [TCP/IP].
- 8 Press the **OK** key. TCP/IP appears.

- 9 Press the Δ or ∇ key to select [On] and then press the **OK** key.

Completed. is displayed and the screen returns to the TCP/IP Settings menu.

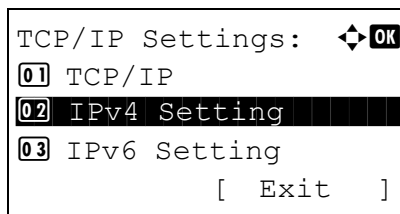

- 10 Press the Δ or ∇ key to select [IPv4 Setting].

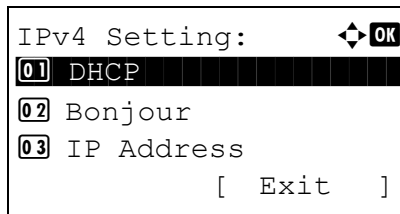

- 11 Press the **OK** key. The IPv4 Setting menu appears.

- 12 Press the Δ or ∇ key to select [DHCP].

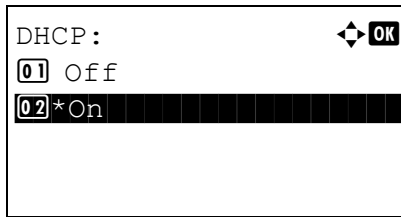

13 Press the **OK** key. DHCP appears.

14 Press the Δ or ∇ key to select [On] or [Off] and then press the **OK** key.

Completed. is displayed and the screen returns to the IPv4 Setting menu.

Bonjour Settings

Select whether or not to use Bonjour. The default setting is *Off*.

Use the procedure below to specify the Bonjour setting.

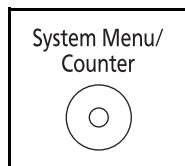

1 Press the **System Menu/Counter** key on the main unit operation panel.

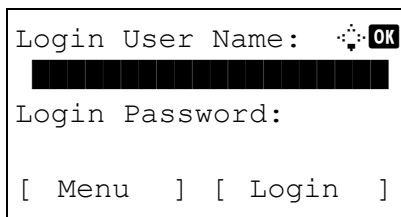

When you are performing user management and have not logged in, a login screen will appear. Then, enter the user ID and password to log in.

NOTE:

- Refer to *Character Entry Method on Appendix-5* for details on entering characters.
- If [Netwk Authentic.] is selected as the user authentication method, press [Menu] (the **Left Select** key) to select the authentication destination.

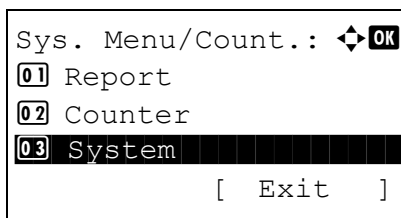

2 In the Sys. Menu/Count. menu, press the Δ or ∇ key to select [System], and then press the **OK** key.

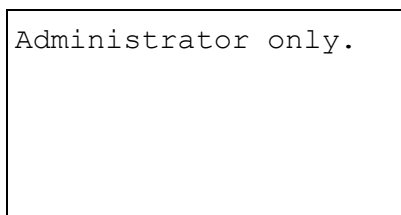

IMPORTANT: To make the settings, you must have logged in using a user ID with administrator privileges.

If you have logged in using a user ID without administrator privileges, the screen will display *Administrator only.* and return to the standby screen.

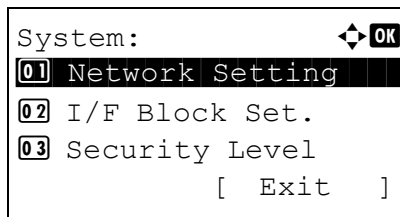

- 3 In the System menu, press the Δ or ∇ key to select [Network Setting].

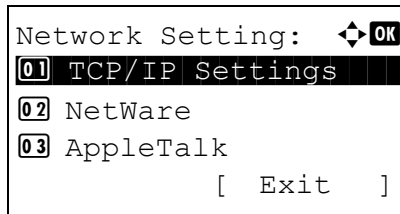

- 4 Press the **OK** key. The Network Setting menu appears.

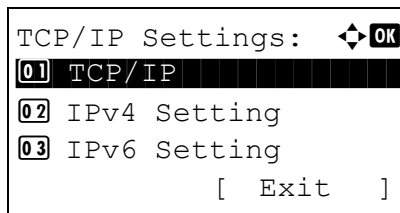

- 5 Press the Δ or ∇ key to select [TCP/IP Settings].
- 6 Press the **OK** key. The TCP/IP Settings menu appears.

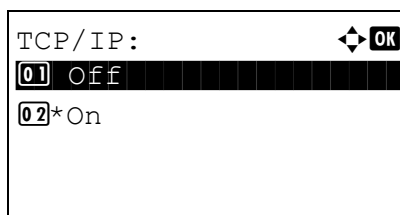

- 7 Press the Δ or ∇ key to select [TCP/IP].
- 8 Press the **OK** key. TCP/IP appears.

- 9 Press the Δ or ∇ key to select [On] and then press the **OK** key.

Completed. is displayed and the screen returns to the TCP/IP Settings menu.

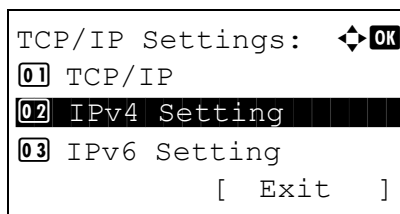

- 10 Press the Δ or ∇ key to select [IPv4 Setting].

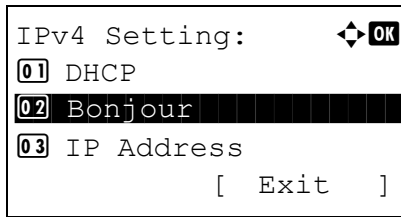

11 Press the **OK** key. The IPv4 Setting menu appears.

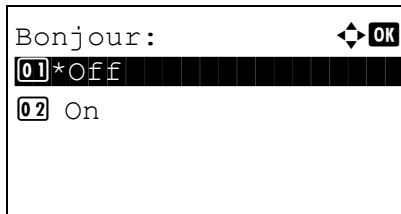

12 Press the Δ or ∇ key to select [Bonjour].

13 Press the **OK** key. Bonjour appears.

14 Press the Δ or ∇ key to select [On] or [Off] and then press the **OK** key.

Completed. is displayed and the screen returns to the IPv4 Setting menu.

AppleTalk Setup

Select the Apple Talk network connection. The default setting is *On*.

Use the procedure below to setup the AppleTalk setting.

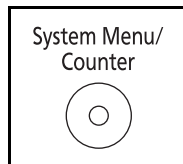

1 Press the **System Menu/Counter** key on the main unit operation panel.

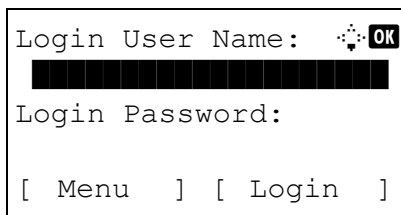

When you are performing user management and have not logged in, a login screen will appear. Then, enter the user ID and password to log in.

NOTE:

- Refer to *Character Entry Method on Appendix-5* for details on entering characters.
- If [Netwk Authentic.] is selected as the user authentication method, press [Menu] (the **Left Select** key) to select the authentication destination.

```

Sys. Menu/Count.:  OK
01 Report
02 Counter
03 System
[ Exit ]

```

- In the Sys. Menu/Count. menu, press the Δ or ∇ key to select [System], and then press the **OK** key.

```

Administrator only.

```

IMPORTANT: To make the settings, you must have logged in using a user ID with administrator privileges.

If you have logged in using a user ID without administrator privileges, the screen will display *Administrator only.* and return to the standby screen.

```

System:  OK
01 Network Setting
02 I/F Block Set.
03 Security Level
[ Exit ]

```

- In the System menu, press the Δ or ∇ key to select [Network Setting].

```

Network Setting:  OK
01 TCP/IP Settings
02 NetWare
03 AppleTalk
[ Exit ]

```

- Press the **OK** key. The Network Setting menu appears.

```

AppleTalk  OK
01 Off
02*On

```

- Press the Δ or ∇ key to select [AppleTalk].
- Press the **OK** key. AppleTalk appears.

- Press the Δ or ∇ key to select [On] or [Off] and then press the **OK** key.

Completed. is displayed and the screen returns to the Network Setting menu.

Installing Software

Install appropriate software on your PC from the included Product Library CD-ROM (Product Library) if you want to use the printer function of this machine or perform TWAIN / WIA transmission or FAX transmission from your PC.

NOTE: Installation on Windows XP, Windows 2000, Server 2003 and Windows Vista must be done by a user logged on with administrator privileges.

Plug and Play is disabled on this device when in Sleep Mode. Wake the device from Low Power Mode or Sleep Mode before continuing. See *Auto Low Power Mode on page 3-4* and *Sleep and Auto Sleep on page 3-5*.

FAX functions available only in FS-1128MFP.

COMMAND CENTER (Settings for E-mail)

COMMAND CENTER is a tool used for tasks such as verifying the operating status of the machine and changing the settings for security, network printing, E-mail transmission and advanced networking.

NOTE: Here, information on the FAX settings has been omitted. For more information on using the FAX, refer to the *Fax Kit Operation Guide*.

FAX functions available only in FS-1128MFP.

The procedure for accessing COMMAND CENTER is explained below.

- 1 Launch your Web browser.
- 2 In the Address or Location bar, enter the machine's IP address.

E.g.) <http://192.168.48.21/>

The web page displays basic information about the machine and COMMAND CENTER as well as their current status.



- 3 Select a category from the navigation bar on the left of the screen. The values for each category must be set separately.

If restrictions have been set for COMMAND CENTER, enter the correct password to access pages other than the startup page. The default setting is admin00. The password can be changed.

For details, refer to the *KYOCERA COMMAND CENTER Operation Guide*.

Sending E-mail

Specifying the SMTP settings allows you to send images loaded onto this machine as E-mail attachments.

To use this function, this machine must be connected to a mail server using the SMTP protocol.

Before sending images loaded onto this machine as E-mail attachments, check the following:

- The network environment used to connect this machine to the mail server
A full-time connection via a LAN is recommended.
- SMTP Settings
Use COMMAND CENTER to register the IP address or host name of the SMTP server.
- If limits have been set on the size of E-mail messages, it may not be possible to send very large E-mails.
- Sender address

The procedure for specifying the SMTP settings is explained below.

- 1 Click Advanced -> SMTP -> General.

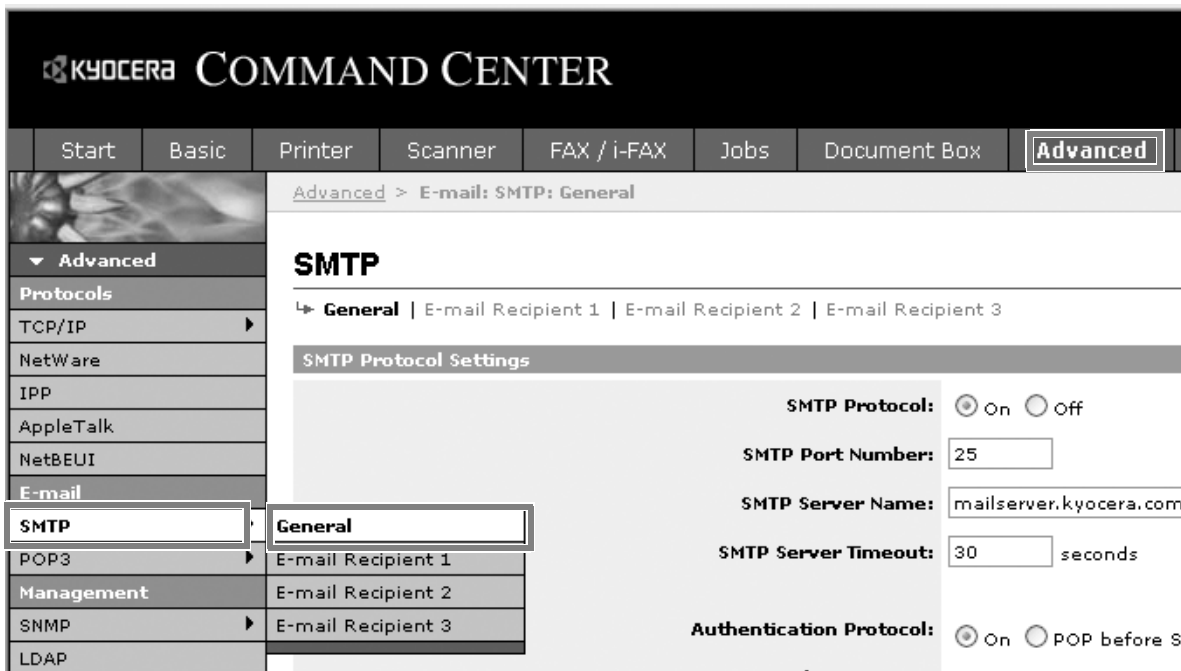

2 Enter the correct settings in each field.

The settings to be specified in the SMTP settings screen are shown below.

Item	Description
SMTP Protocol	Enables or disables SMTP protocol. To use E-mail, this protocol must be enabled.
SMTP Port Number	Set the SMTP Port Number or use the SMTP default port 25.
SMTP Server Name	Enter the SMTP server IP address or its name. The maximum length of the SMTP server name and IP address is 64 characters. If entering the name, a DNS server address must also be configured. The DNS server address may be entered on the TCP/IP General tab.
SMTP Server Timeout	Enter the default time out for the server in seconds.
Authentication Protocol	Enables or disables the SMTP authentication protocol or sets POP before SMTP as the protocol. The SMTP authentication supports Microsoft Exchange 2000.
Authenticate as	Authentication can be set from three POP3 accounts or you can choose a different account.
Login User Name	When Other is selected for Authenticate, the login user name set here will be used for SMTP authentication. The maximum length of the login user name is 64 characters.
Login Password	When Other is selected for Authenticate, the password set here will be used for authentication. The maximum length of the login password is 64 characters.
POP before SMTP Timeout	Enter the timeout (in seconds) if you chose POP before SMTP as the Authentication Protocol.
Test	This will test if the SMTP connection can be successfully established.
E-mail Size Limit	Enter the maximum size of E-mail that can be sent in kilobytes. When the value is 0, the limitation for E-mail size is disabled.
Sender Address	Enter the E-mail address of the person responsible for the machine, such as the machine administrator, so that a reply or non-delivery report will go to a person rather than to the machine. The sender address must be entered correctly for SMTP authentication. The maximum length of the sender address is 128 characters.
Signature	Enter the signature. The signature is free form text that will appear at the end of the E-mail body. It is often used for further identification of the machine. The maximum length of the signature is 512 characters.
Domain Restriction	Enter the domain names that can be permitted or rejected. The maximum length of the domain name is 32 characters. You can also specify E-mail addresses.

3 Click Submit.

Loading Paper

Paper can be loaded standardly in the cassette and the multi purpose tray. A paper feeder is also available as an option (refer to *Optional Equipment on Appendix-2*).

Before Loading Paper

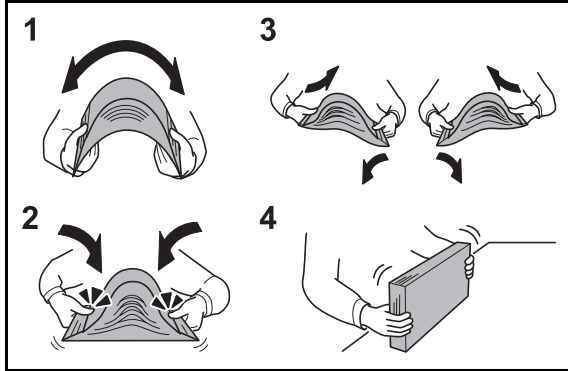

When you open a new package of paper, fan the sheets to separate them slightly prior to loading in the following steps.

- 1 Bend the whole set of sheets to swell them in the middle.
- 2 Hold the stack at both ends and stretch it while keeping the entire stack swelled.
- 3 Raise the right and left hands alternately to create a gap and feed air between the papers.
- 4 Finally, align the papers on a level, flat table.

If the paper is curled or folded, straighten it before loading. Paper that is curled or folded may cause a jam.

CAUTION: If you copy onto used paper (paper already used for copying), do not use paper that is stapled or clipped together. This may damage the machine or cause poor image quality.

NOTE: If printouts are curled or not neatly stapled, turn the stack in the cassette upside down.

Avoid exposing opened paper to high temperatures and high humidity as dampness can be a cause of problems. Seal any remaining paper after loading in the multi purpose tray or cassettes back in the paper storage bag.

If the machine will not be used for a prolonged period, protect all paper from humidity by removing it from the cassettes and sealing it in the paper storage bag.

NOTE: If you use special paper such as letterhead, paper with holes or paper with pre-prints like logo or company name, refer to *Paper on Appendix-9*.

Loading Paper in the Cassettes

The standard cassette will each hold plain paper, recycled paper or color paper.

The standard cassette holds up to 250 sheets of A4 or smaller plain paper (80 g/m²).

The following paper sizes are supported: Legal, Oficio II, Letter, Executive, Statement, A4, B5, A5, A6, Folio, and 16K.

2

IMPORTANT:

- You should not use inkjet printer paper or any paper with a special surface coating. (Such papers may cause paper jams or other faults.)
- When using media types other than plain paper (such as recycled or colored paper), always specify the media type setting. (Refer to *Specifying Paper Size and Media Type for the Cassettes* on page 2-38)
The cassettes can hold paper with weights up to 120 g/m².
- Do not load thick paper that is heavier than 120 g/m² in the cassettes. Use the multi purpose tray for paper that is heavier than 120 g/m².

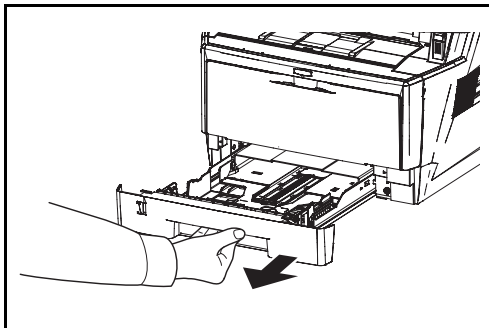

- 1 Pull the cassette completely out of the machine.

IMPORTANT: When pulling the cassette out of the machine, ensure it is supported and does not fall out.

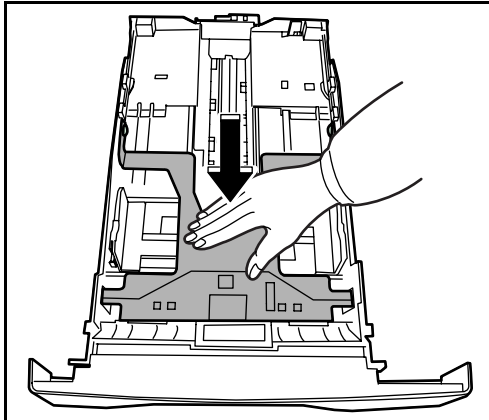

- 2 Press the bottom plate down until it locks.

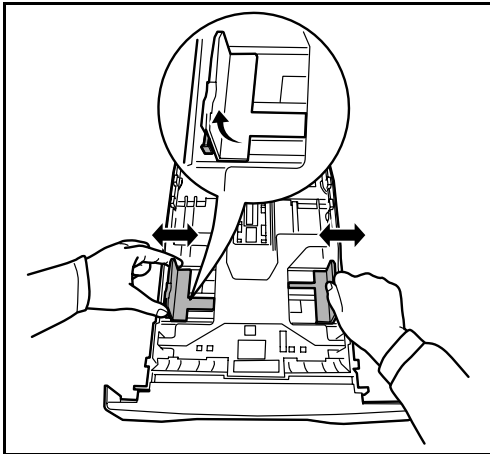

- 3 Adjust the position of the paper width guides located on the left and right sides of the cassette. Press the paper width adjusting tab on the left guide and slide the guides to the paper size required.

NOTE: Paper sizes are marked on the cassette.

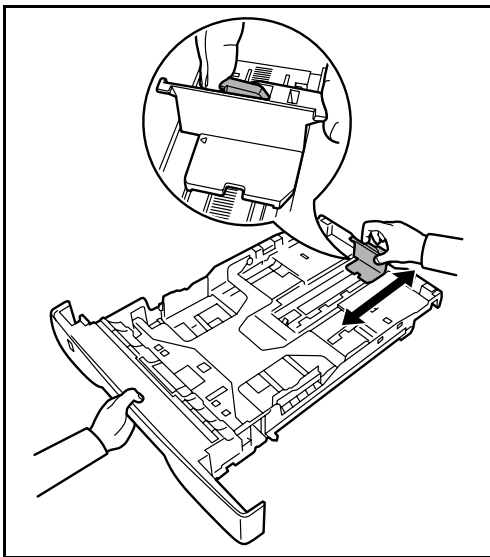

- 4 Adjust the paper length guide to the paper size required.

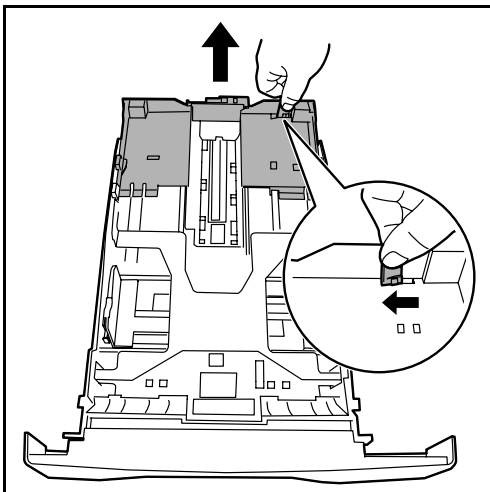

If you are going to use paper that is longer than A4, pull out the extension paper cassette by pushing the release lever one by one and adjust it to the desired paper size.

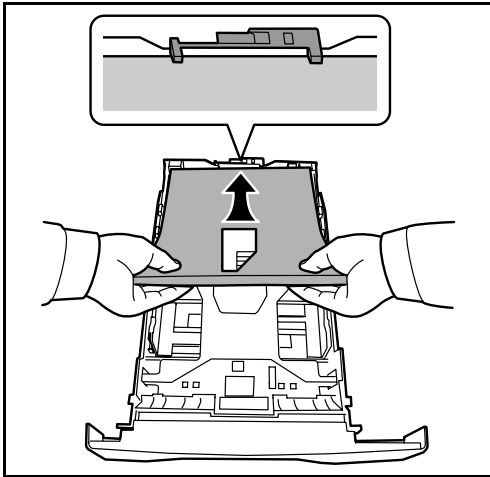

- 5** Load the paper in the cassette. Ensure the side to be printed is facing down and the paper is not folded, curled, or damaged.

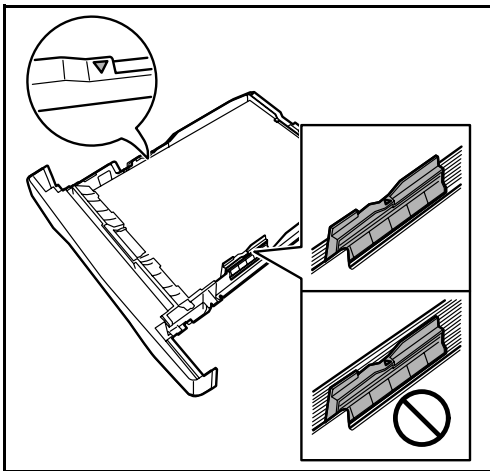

IMPORTANT: Do not load paper above the triangle mark located on the width guide.

- Before loading the paper, be sure that it is not curled or folded. Paper that is curled or folded may cause paper jams.
- Ensure that the loaded paper does not exceed the level indicator (see illustration below).
- When loading the paper, keep the side that was closest the package seal facing up.
- The paper length and width guides must be adjusted to the paper size. Loading the paper without adjusting these guides may cause skewed feeding and paper jams.
- Be sure that the paper length and width guides rest securely against the paper. If there is a gap, readjust the guides to fit the paper.

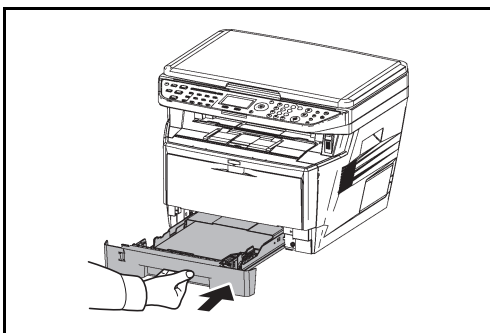

- 6** Insert the paper cassette into the slot in the machine. Push it straight in as far as it will go.

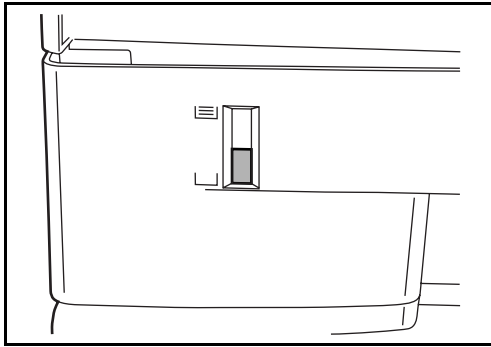

There is a paper gauge on the left side of the front of the paper cassette to indicate the remaining paper supply. When paper is exhausted, the pointer will go down to the level of (empty).

NOTE: If the machine will not be used for a prolonged period, protect all paper from humidity by removing it from the cassettes and sealing it in the paper storage bag.

- 7 Select the media type (plain, recycled, etc.) loaded in the cassette. (Refer to *Specifying Paper Size and Media Type for the Cassettes* on page 2-38.)

Loading Paper in the Multi Purpose Tray

The multi purpose tray will hold up to 50 sheets of A4 or smaller plain paper (80 g/m²).

The multi purpose tray accepts paper sizes from A4 to A6 and Hagaki and from Legal to Statement-R, and 16K. Be sure to use the multi purpose tray when you print on any special paper.

IMPORTANT: When using media types other than plain paper (such as recycled or colored paper), always specify the media type setting. (Refer to *Specifying Paper Size and Media Type for the Multi Purpose Tray* on page 2-41.) If you are using a paper weight of 106 g/m² or more, set the media type to *Thick*.

The capacity of the multi purpose tray is as follows.

- A4 or smaller plain paper (80 g/m²), recycled paper or color paper: 50 sheets
- Hagaki: 15 sheets
- OHP film: 1 sheet
- Envelope DL, Envelope C5, Envelope #10 (Commercial #10), Monarch, Youkei 4, Youkei 2: 1 sheet

NOTE: When you load custom size paper, enter the paper size by referring to *Specifying Paper Size and Media Type for the Multi Purpose Tray* on page 2-41.

When you use special paper such as transparencies or thick paper, select the media type by referring to *Specifying Paper Size and Media Type for the Multi Purpose Tray* on page 2-41.

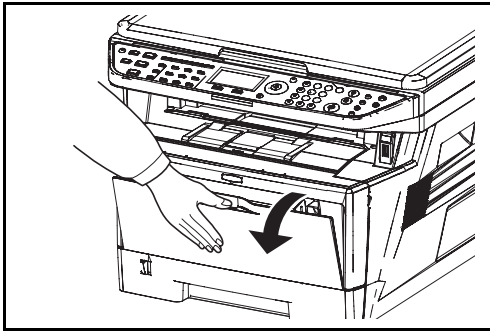

1 Pull the MP tray towards you until it stops.

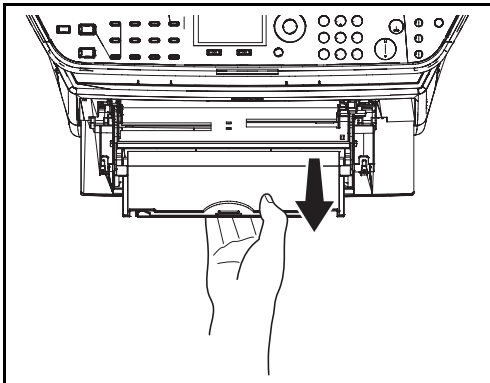

2 Pull out the subtray.

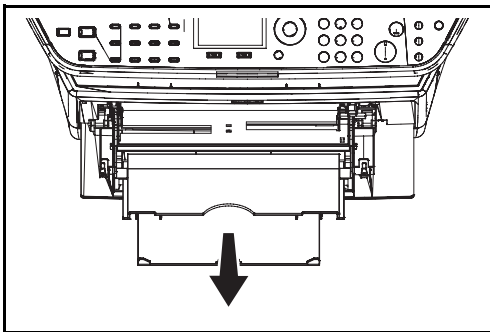

3 Adjust the position of the paper guides on the MP tray. Standard paper sizes are marked on the MP tray or Manual Feed tray. For standard paper sizes, slide the paper guides to the corresponding mark.

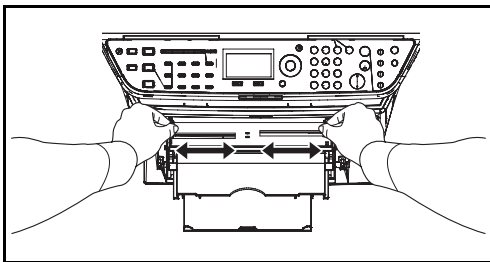

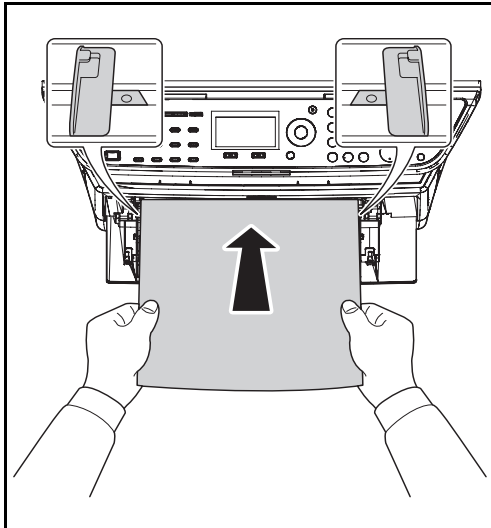

- 4 Align the paper with the paper guides and insert as far as it will go.

IMPORTANT: Keep the side that was closest the package seal facing up.

Curled paper must be uncurled before use.

Straighten the top edge if it is curled.

When loading paper into the multi purpose tray, check that there is no paper left over in the tray from a previous job before loading the paper. If there is just a small amount of paper left over in the multi purpose tray and you want to add more, first remove the left-over paper from the tray and include it with the new paper before loading the paper back into the tray.

Loading Envelopes

1 envelope may be loaded in the multi purpose tray.

Acceptable envelope sizes are as follows.

Acceptable Envelope	Size
Hagaki	148×100 (mm)
Oufuku Hagaki	148×200 (mm)
Youkei 2	162×114 (mm)
Youkei 4	235×105 (mm)
Monarch	3 7/8"×7 1/2"
Envelope #10 (Commercial #10)	4 1/8"×9 1/2"
Envelope DL	110×220 (mm)
Envelope C5	162×229 (mm)
Executive	7 1/4"×10 1/2"
Envelope #9 (Commercial #9)	3 7/8"×8 7/8"
Envelope #6 (Commercial #6 3/4)	3 5/8"×6 1/2"
ISO B5	176×250 (mm)

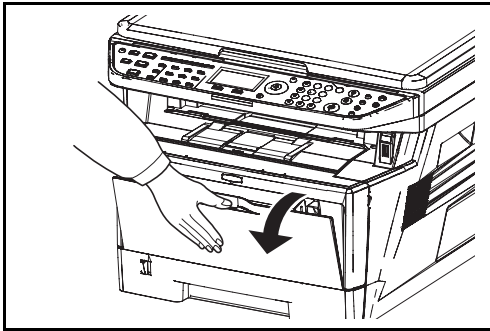

1 Pull the MP tray towards you until it stops.

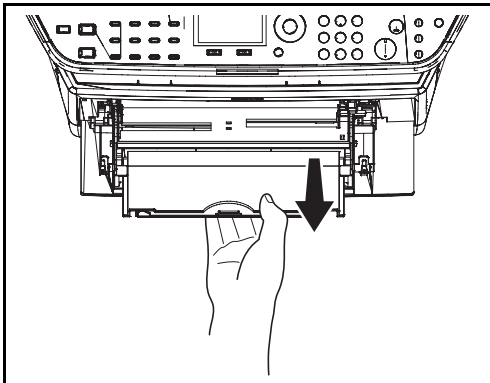

2 Pull out the subtray.

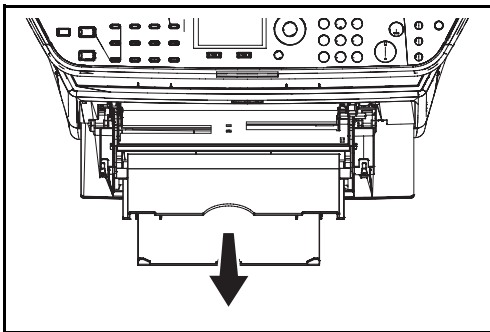

3 Adjust the position of the paper guides on the MP tray. Standard paper sizes are marked on the MP tray or Manual Feed tray. For standard paper sizes, slide the paper guides to the corresponding mark.

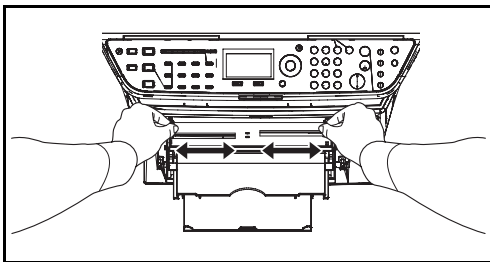

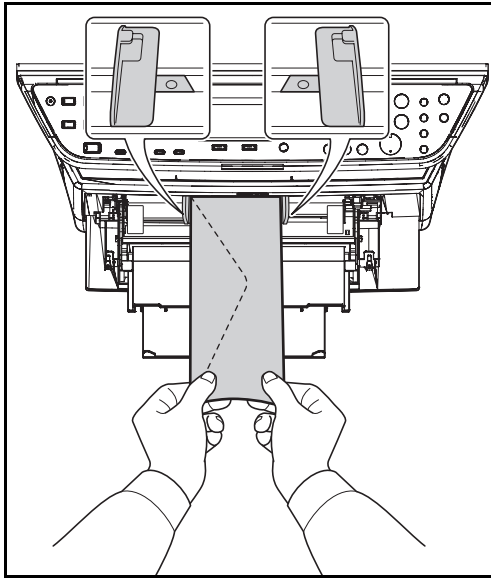

4 Align the paper with the paper guides and insert as far as it will go.

5 For landscape form envelopes, close the flap. Insert the envelope all the way along the width guides, keeping the printing side face-up and the edge with the flap facing towards you.

For portrait form envelopes, close the flap. Insert the envelope all the way along the width guides, keeping the printing side face-up and the edge with the flap facing the insertion slot.

When you load envelopes or cardstock in the multi purpose tray

Load envelope with the print side facing up.

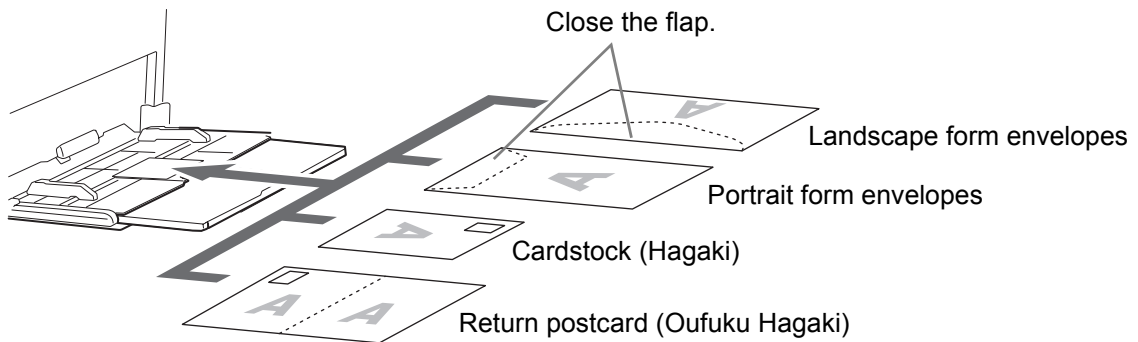

NOTE: Use unfolded return postcard (Oufuku Hagaki).

IMPORTANT: How to load envelopes (orientation and facing) will differ depending on the type of envelope. Be sure to load it in correctly, otherwise printing may be done in the wrong direction or on the wrong face.

NOTE: When you load envelopes in the multi purpose tray, select the envelope type by referring to *Specifying Paper Size and Media Type for the Multi Purpose Tray* on page 2-41.

Specifying Paper Size and Media

The default paper size setting for cassette, for multi purpose tray and for the optional paper feeder (cassettes 2 and 3) is [Letter], and the default media type setting is [Plain].

To fix the type of paper to be used in cassettes, specify the paper size and media type setting. (Refer to *Specifying Paper Size and Media Type for the Cassettes on page 2-38.*)

To fix the type of paper to be used in multi purpose tray, specify the paper size setting. (Refer to *Specifying Paper Size and Media Type for the Multi Purpose Tray on page 2-41.*)

Specifying Paper Size and Media Type for the Cassettes

To fix the type of paper to be used in cassette or the optional paper feeder (cassettes 2 and 3), specify the paper size. Also, you use a media type other than plain paper, specify the media type setting.

Selection Item	Selectable Size/Type
Paper Size	Select from the standard sizes. Selectable paper sizes are as follows. Inch size: Letter, Legal, Statement and Oficio II Metric size: A4, A5, A6, B5, Folio, and 16K
Media Type	Plain, Rough, Recycled, Preprinted, Bond, Color, Prepunched, Letterhead, High Quality and Custom 1~8

* To change to a media type other than *Plain*, refer to *Paper Weight on page 8-17.*

NOTE: If using the FS-1128MFP, the available media types for printing received faxes are as shown below. *Plain, Recycled, Bond, Color, High Quality and Rough*

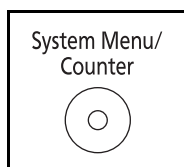

- 1 Press the **System Menu/Counter** key on the main unit operation panel.

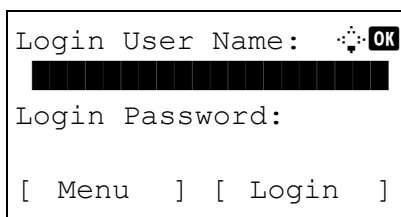

When you are performing user management and have not logged in, a login screen will appear. Then, enter the user ID and password to log in.

NOTE:

- Refer to *Character Entry Method on Appendix-5* for details on entering characters.
- If [Netwk Authentic.] is selected as the user authentication method, press [Menu] (the **Left Select** key) to select the authentication destination.

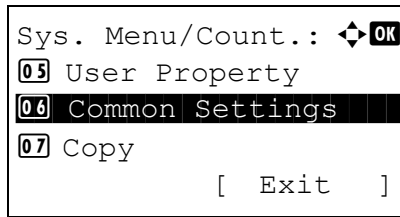

- 2 In the Sys. Menu/Count. menu, press the Δ or ∇ key to select [Common Settings].

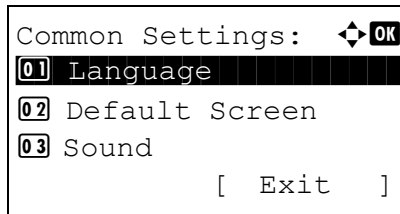

- 3 Press the **OK** key. The Common Settings menu appears.

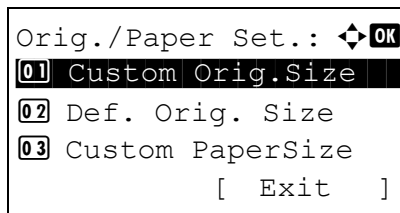

- 4 Press the Δ or ∇ key to select [Orig./Paper Set.].

- 5 Press the **OK** key. The Orig./Paper Set. menu appears.

- 6 Press the Δ or ∇ key to select from [Cassette 1 Set.] to [Cassette 3 Set.].

NOTE: [Cassette 2] and [Cassette 3] are shown when the optional cassettes are installed.

Follow the steps below when you select the main unit cassette (Cassette 1). Operate in a similar fashion when you select an optional cassette (Cassette 2 or 3).

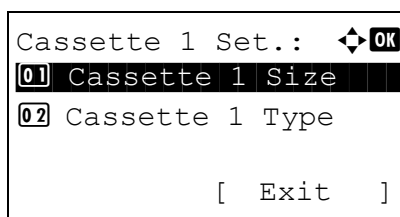

- 7 Press the **OK** key. The Cassette 1 Set. menu appears.

- 8 Press the Δ or ∇ key to select [Cassette 1 Size].

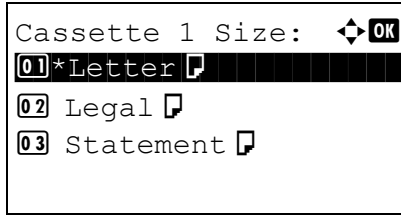

9 Press the **OK** key. Cassette 1 Size appears.

10 Press the Δ or ∇ key to select the desired paper size and then press the **OK** key.

Completed. is displayed and the screen returns to the Cassette 1 Set. menu.

11 Press the Δ or ∇ key to select [Cassette 1 Type].

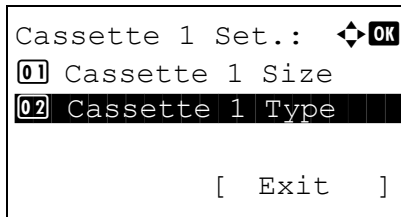

12 Press the **OK** key. Cassette 1 Type appears.

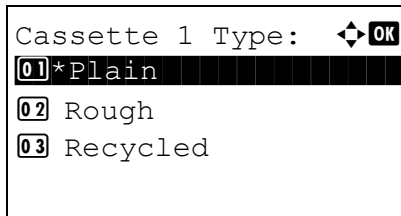

13 Press the Δ or ∇ key to select the desired paper type and then press the **OK** key.

Completed. is displayed and the screen returns to the Cassette 1 Set. menu.

Specifying Paper Size and Media Type for the Multi Purpose Tray

To fix the type of paper to be used in the multi purpose tray, specify the paper size. When using other than a plain paper, specify the media type.

Item		Description
Paper Size	Standard Sizes	Select from the standard sizes. Selectable paper sizes are as follows. Inch size: Letter, Legal, Statement, Executive, and Oficio II Metric size: A4, A5, A6, B5, B6, Folio and 16K
	Others	Select from special standard sizes and custom sizes. Selectable paper sizes are as follows. ISO B5, Envelope #10 (Commercial #10), Envelope #9 (Commercial #9), Envelope #6 (Commercial #6 3/4), Envelope Monarch, Envelope DL, Envelope C5, Hagaki, Oufuku Hagaki, Youkei 4, Youkei 2
	Size Entry	Enter the size not included in the standard size. Selectable paper sizes are as follows. Inch size X (Horizontal): 5.83~14.02" (in 0.01" increments), Y (Vertical): 2.75~8.50" (in 0.01" increments) Metric size X (Horizontal): 148~356 mm (in 1mm increments), Y (Vertical): 80~216 mm (in 1mm increments)
Media Type		Selectable media types are as follows. Plain, Transparency, Rough, Vellum, Labels, Recycled, Preprinted, Bond, Cardstock, Color, Prepunched, Letterhead, Envelope, Thick, High Quality and Custom 1~8

* To change to a media type other than *Plain*, refer to *Paper Weight* on page 8-17.

NOTE: If using the FS-1128MFP and the multi purpose tray is used to print a received FAX, the available media types are as shown below.

Plain, Recycled, Bond, Color, High Quality and Rough

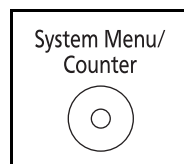

- 1 Press the **System Menu/Counter** key on the main unit operation panel.

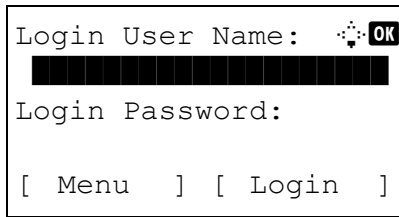

When you are performing user management and have not logged in, a login screen will appear. Then, enter the user ID and password to log in.

NOTE:

- Refer to *Character Entry Method on Appendix-5* for details on entering characters.
- If [Netwk Authentic.] is selected as the user authentication method, press [Menu] (the **Left Select** key) to select the authentication destination.

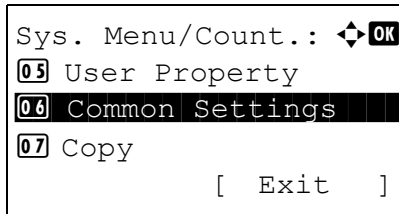

2 In the Sys. Menu/Count. menu, press the Δ or ∇ key to select [Common Settings].

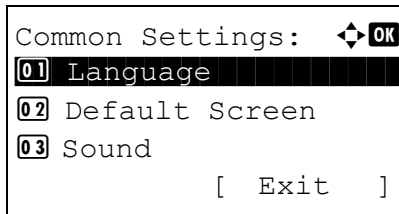

3 Press the **OK** key. The Common Settings menu appears.

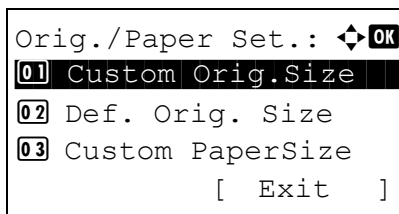

4 Press the Δ or ∇ key to select [Orig./Paper Set.].

5 Press the **OK** key. The Orig./Paper Set. menu appears.

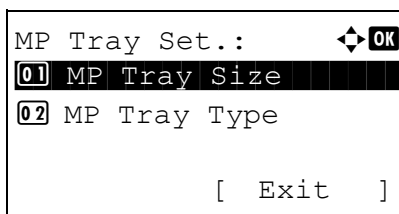

6 Press the Δ or ∇ key to select [MP Tray Set.].

7 Press the **OK** key. The MP Tray Set. menu appears.

8 Press the Δ or ∇ key to select [MP Tray Size].

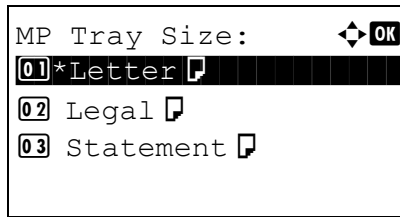

- 9 Press the **OK** key. MP Tray Size appears.

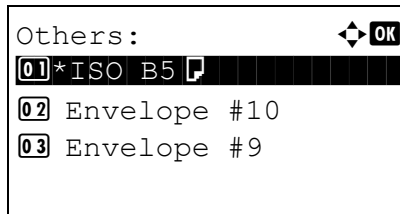

- 10 Press the Δ or ∇ key to select the desired paper size and then press the **OK** key.

If you select [Others], select one of the other options and then press the **OK** key.

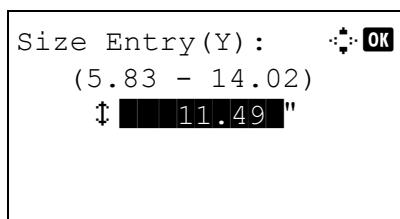

If you select [Size Entry], use the numeric keys to enter the Y (vertical) size and press the **OK** key, and then enter the X (horizontal) size and press the **OK** key.

Completed. is displayed and the screen returns to the MP Tray Set. menu.

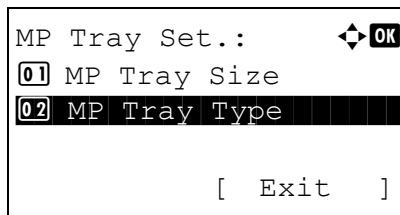

- 11 Press the Δ or ∇ key to select [MP Tray Type].

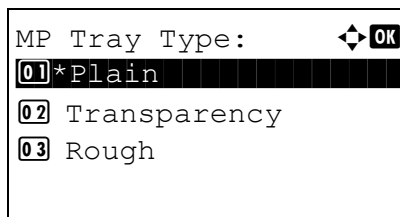

- 12 Press the **OK** key. MP Tray Type appears.

- 13 Press the Δ or ∇ key to select the desired paper type and then press the **OK** key.

Completed. is displayed and the screen returns to the MP Tray Set. menu.

Loading Originals

Follow the steps below to load originals for copying, sending or storing.

Placing Originals on the Platen

You may place books or magazines on the platen in addition to ordinary sheet originals.

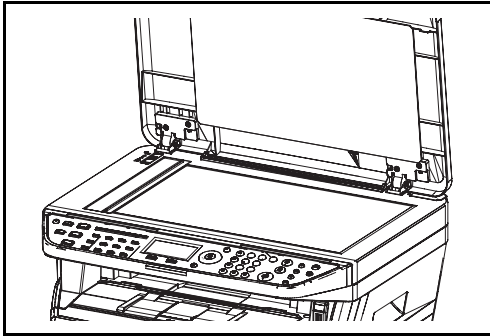

- 1 Open the original cover.

NOTE: If the optional document processor (DP-110) is installed, open the document processor. Before opening the document processor, be sure that there are no originals left on the original table or on the original eject table. Originals left on the original table or on the original eject table may fall off when the document processor is opened.

Keep the document processor open if the original is 30 mm or thicker.

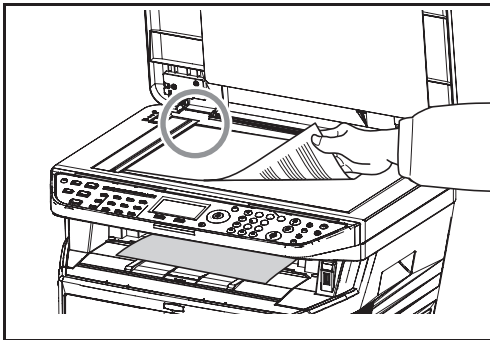

- 2 Place the original. Put the scanning side facedown and align it flush against the original size indicator plates with the back left corner as the reference point.

- 3 Close the original cover.

IMPORTANT: Do not push the original cover forcefully when you close it. Excessive pressure may crack the platen glass.

Do not close the document processor when the original is 30 mm or thicker. The connector of the document processor will be removed from the machine.

NOTE: Shadows may be produced around the edges and in the middle of open-faced originals.

CAUTION: Do not leave the document processor open as there is a danger of personal injury.



Loading Originals in the Document Processor

The optional document processor automatically scans each sheet of multiple originals. Both sides of two-sided originals are scanned.

Part Names of the Document Processor

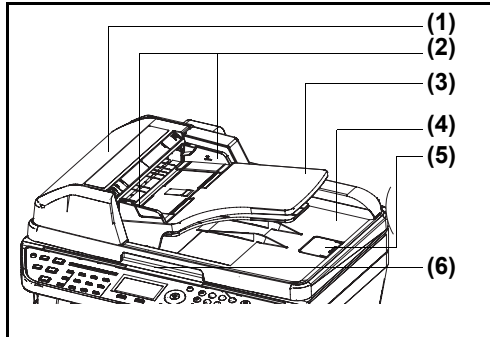

- (1) Top cover
- (2) Original width guides
- (3) Original table
- (4) Original eject table
- (5) Original stopper
- (6) Opening handle

Originals Supported by the Document Processor

The document processor supports the following types of originals.

Weight	50 to 120 g/m ² (duplex: 50 to 110 g/m ²)
Size	Maximum A4 to Minimum A5 Maximum Legal to Minimum Statement
Capacity	Plain paper, Colored paper, Recycled paper, High quality paper: 50 sheets Thick paper (110 g/m ²): 36 sheets Thick paper (120 g/m ²): 33 sheets Art paper: 1 sheet

Originals Not Supported by the Document Processor

Do not use the document processor for the following types of originals.

- Soft originals such as vinyl sheets
- Transparencies such as OHP film
- Carbon paper
- Originals with very slippery surfaces
- Originals with adhesive tape or glue
- Wet originals
- Originals with correction fluid which is not dried
- Irregularly shaped (non-rectangular) originals
- Originals with cut-out sections
- Crumpled paper
- Originals with folds (Straighten the folds before loading. Failure to do so may cause the originals to jam).
- Originals bound with clips or staples (Remove the clips or staples and straighten curls, wrinkles or creases before loading. Failure to do so may cause the originals to jam).

How to Load Originals

IMPORTANT: Before loading originals, be sure that there are no originals left on the original eject table. Originals left on the original eject table may cause the new originals to jam.

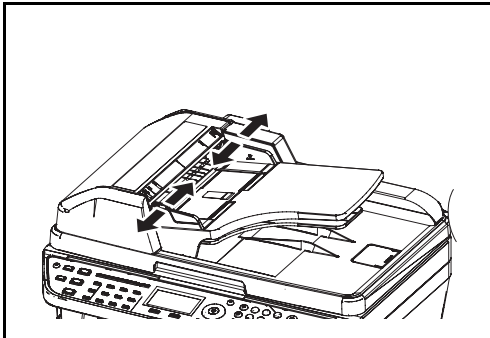

- 1 Adjust the original width guides to fit the originals.

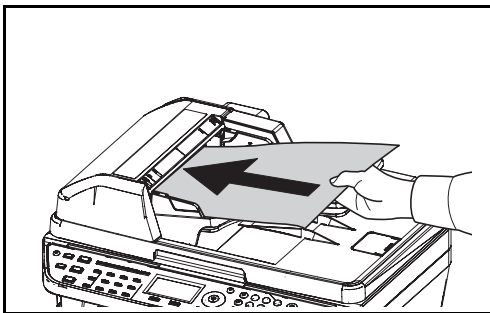

- 2 Place the originals. Put the side to be scanned (or the first side of two-sided originals) face-up. Slide the leading edge into the document processor as far as it will go.

IMPORTANT: Confirm that the original width guides exactly fit the originals. If there is a gap, readjust the original width guides. The gap may cause the originals to jam.

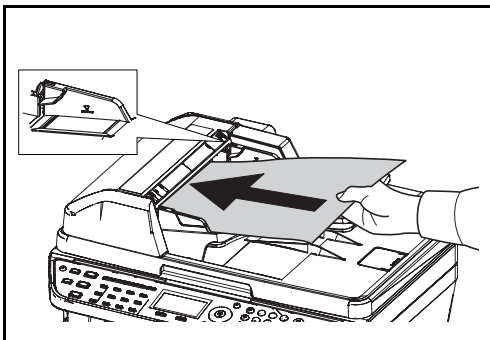

Ensure that loaded originals do not exceed the level indicator. Exceeding the maximum level may cause the originals to jam (see the figure).

Originals with punched holes or perforated lines should be placed in such a way that the holes or perforations will be scanned last (not first).

3 Basic Operation

This chapter explains the following operations.

- Power On/Off 3-2
- Auto Low Power Mode..... 3-4
- Sleep and Auto Sleep 3-5
- Login/Logout 3-6
- One-Touch Keys and Program Keys..... 3-7
- Message Display..... 3-8
- Copying..... 3-9
- Printing - Printing from Applications..... 3-18
- Sending..... 3-20
- Confirm Destination Screen 3-27
- Specifying Destination 3-28
- Canceling Jobs 3-31
- Checking Remaining Toner and Paper 3-32
- Program (Copying and Sending) 3-33

Power On/Off

Power On

When the main power indicator is lit...

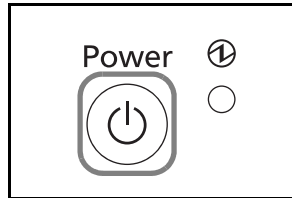

Press the **Power** key.

When the main power indicator is off...

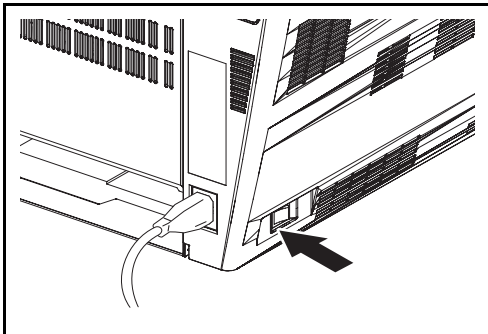

Turn the main power switch on.

IMPORTANT: When turning off the main power switch, do not turn on the main power switch again immediately. Wait more than 5 seconds, and then turn on the main power switch.

Power Off

Before turning off the main power switch, press the **Power** key on the operation panel to off. Make sure that the **Power** and the **memory** indicator are off before turning off the main power switch.

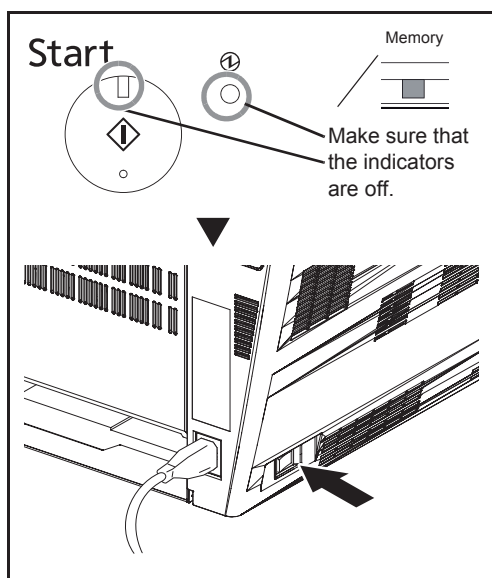

In case of not using the machine for a extended period of time



CAUTION: If this machine will be left unused for an extended period (e.g. overnight), turn it off at the main power switch. If the machine will not be used for an even longer period of time (e.g. vacation), remove the power plug from the outlet as a safety precaution. If using the FS-1128MFP, note that turning the machine off at the main power switch disables fax transmission and reception.

CAUTION: Remove paper from the cassettes and seal it in the paper storage bag to protect it from humidity.

Auto Low Power Mode

Auto Low Power Mode automatically switches the machine into Low Power Mode if left idle for 2 minutes.

Sleep and Auto Sleep

Sleep

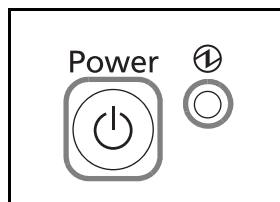

To enter Sleep, press the **Power** key. Message Display and all indicators on the operation panel will go out to save a maximum amount of power except the Main Power indicator. This status is referred to as Sleep.

If print data is received during Sleep, the print job is performed while the Message Display remains unlit.

If you are using the FS-1128MFP, received fax data is printed out while the operation panel also remains unlit.

To resume, press the **Power** key. The machine will be ready to operate in about 15 seconds.

Note that ambient environmental conditions, such as ventilation, may cause the machine to respond more slowly.

Auto Sleep

Auto Sleep automatically switches the machine into Sleep Mode if left idle for 15 minutes.

Login/Logout



If user login administration is enabled, it is necessary to enter the login user name and password to use the machine.

NOTE: You will be unable to log in if you forget your login user name or login password. In this event, log in with administrator privileges and change your login user name or login password.

Login

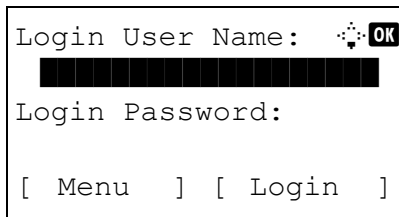
NOTE: Refer to *Character Entry Method on Appendix-5* for details on entering characters.



Login User Name:  

Login Password:

[Menu] [Login]

- 1** If the screen shown appears during operations, enter the login user name.
- 2** Press the ∇ key. The input cursor moves to Login Password.
- 3** Enter the login password.
Press the Δ key to move the input cursor to Login User Name.
- 4** Check the login user name and password are correct, and press [Login] (the **Right Select** key).

NOTE: If [Netwk Authentic.] is selected as the user authentication method, press [Menu] (the **Left Select** key) to select the authentication destination.

Logout

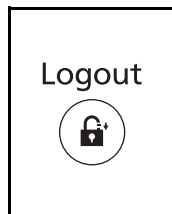

To logout from the machine, press the **Logout** to return to the login user name/password entry screen.

One-Touch Keys and Program Keys

The one-touch keys and program keys on the operation panel are described below.

One-Touch Key

Register destinations to one-touch keys, and you can enter the desired destination by pressing the applicable one-touch key. For registering a destination to a one-touch key, refer to *Adding a Destination on One-touch Key on page 8-124*.

Entering Destination with One-touch Key

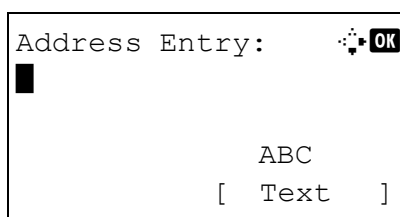

- 1 In Address Entry, press the **one-touch** key where the desired destination is registered.

Recalling from One-touch Keys 1 to 11

Press the **one-touch** key where the destination is registered.

Recalling from One-touch Keys 12 to 22

Press the **Shift Lock** key to turn on the lamp next to the keys, and then press the **one-touch** key where the destination is registered.

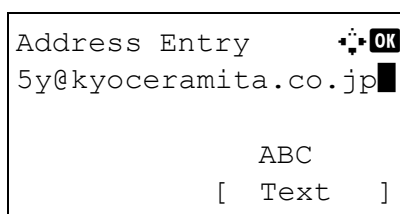

- 2 The destination registered to the **one-touch** key is recalled and automatically entered on the screen.

IMPORTANT: Any destination already entered is overwritten.

Program Keys

Settings of various functions frequently used for copying and sending can be collectively registered as a program. Then, you can change the current settings of various functions to the registered settings by just pressing the applicable program key. For registering settings to a program key, refer to *Program (Copying and Sending) on page 3-33*.

Message Display



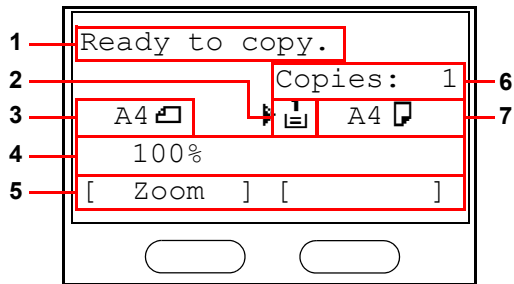

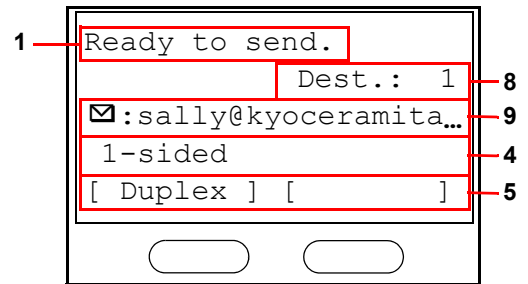

The following examples explain the messages and icons used on the message display.



Copier Screen



Send Screen

Reference number	Meaning
1	Indicates the current status of the machine. Also displays the title of the current menu whenever the operation panel is being used.
2	Displays an icon that indicates the currently selected source of paper feed. The meaning of each icon is as indicated below. <ul style="list-style-type: none">  The standard paper cassette is currently selected. When this icon is displayed as , there is no paper in the cassette.  The paper cassette for the optional paper feeder is currently selected. When this icon is displayed as  or , there is no paper in the cassette.  The MP Tray is currently selected. When this icon is displayed as , there is no paper in the MP Tray.
3	Displays the size of the original(s).
4	Displays the current setting when there is a corresponding menu that can be selected using the left or right Select keys.
5	Displays the title of the corresponding menu that can be selected using the left or right Select keys.
6	Displays the number of copies.
7	Displays the paper size to be copied.
8	Displays the number of destinations.
9	Displays the destination.

Copying

Follow the steps as below for basic copying.

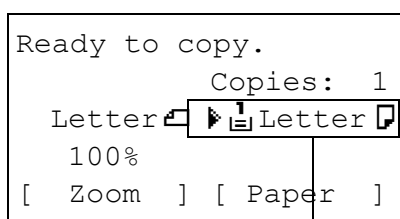
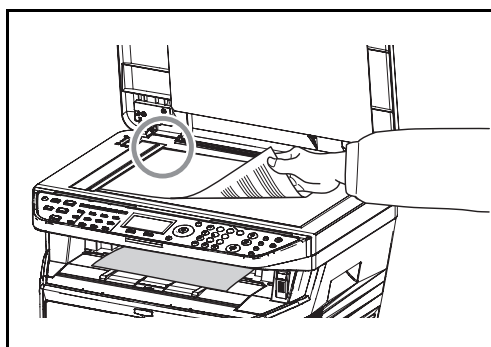
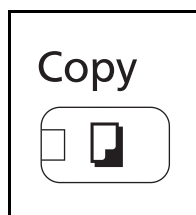

Paper source

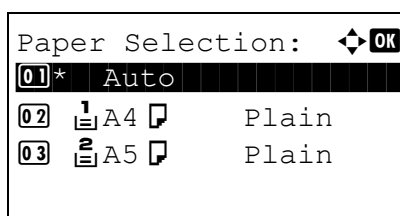

- 1 Press the **Copy** key when the **Copy** key/indicator is off.

NOTE: If the Message Display is turned off, press the **Power** key and wait for the machine to warm up.

- 2 Place the originals on the platen or in the optional document processor.

NOTE: For loading instructions, refer to *Loading Originals* on page 2-44.

- 3 The paper source for copying is the location displayed on the panel.

When you need to change the paper source, use the Paper Selection menu. If [Auto] is selected, the most suitable paper source is automatically selected.

For specifying the paper source, refer to *Paper Selection* on page 4-4.

- 4 Use the numeric keys to enter the copy quantity. Specify the desired number up to 999.

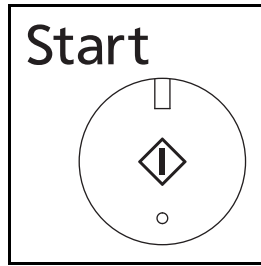

5 Press the **Start** key to start copying.

6 Remove the finished copies from the top tray.

Adjusting Density

Use this procedure to adjust the density when copying.

Density Adjustment Option	Description
Manual	Adjust density using 7 levels.
Auto	Optimum density is selected according to the density of the original.

NOTE: You may choose Auto mode as the default setting (refer to *Density on page 8-37*).

The procedure for adjusting the density of copies is explained below.

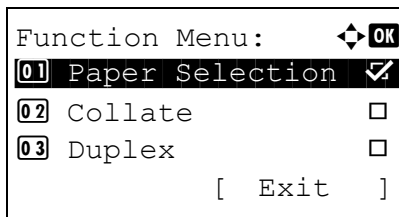

1 Press the **Function Menu** key. Function Menu appears.

2 Press the Δ or ∇ key to select [Density].

3 Press the **OK** key. Density appears.

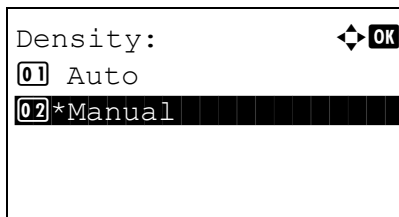

4 Press the Δ or ∇ key to select [Auto] or [Manual].

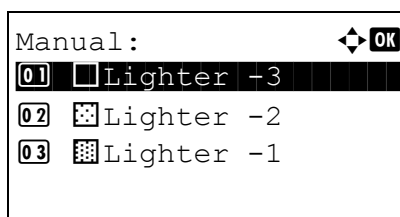

- 5 Press the **OK** key.

When [Manual] is selected, Manual appears. Press the Δ or ∇ key to select your desired density and then press the **OK** key.

Completed. is displayed and the screen returns to the basic screen.

- 6 Press the **Start** key. Copying begins.

3

Selecting Image Quality

Select image quality suited to the type of original.

The table below shows the quality options.

Image Quality Option	Description
Text+Photo	For originals with both text and photographs.
Photo	For photos taken with a camera.
Text	For originals primarily consisting of text.

The procedure for selecting the quality of copies is explained below.

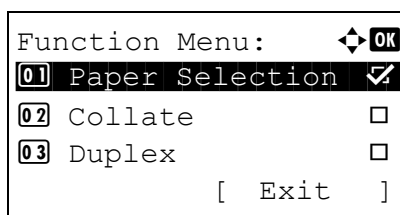

- 1 Press the **Function Menu** key. Function Menu appears.

- 2 Press the Δ or ∇ key to select [Original Image].

- 3 Press the **OK** key. Original Image appears.

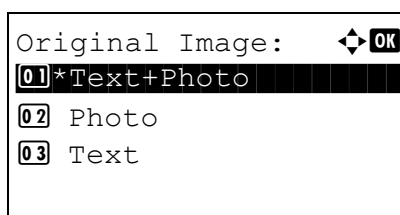

- 4 Press the Δ or ∇ key to select the image quality suited to the type of original.
- 5 Press the **OK** key. *Completed.* is displayed and the screen returns to the basic screen.
- 6 Press the **Start** key. Copying begins.

Zoom Copying

Adjust the magnification to reduce or enlarge the original image. The following zoom options are available.

Auto Zoom

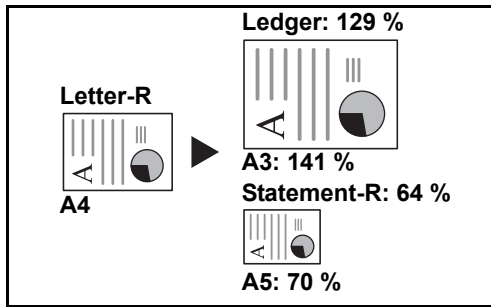

Automatically reduces or enlarges the original image suitably to the selected paper size.

Zoom Entry

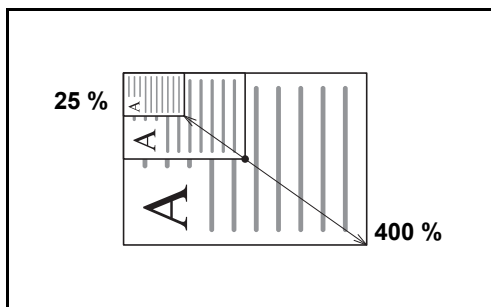

Manually reduces or enlarges the original image in 1% increments between 25% and 400%.

Standard Zoom

Reduces or enlarges at preset magnifications.

The following magnifications are available.

Model	Zoom Level (OriginalCopy)	
Inch Models	Standard	100%, 400% (Max.), 200%, 129% (Statement >> Letter), 78% (Legal >> Letter), 64% (Letter >> Statement), 50%, 25% (Min.)
	Other	141% (A5 >> A4), 115% (B5 >> A4), 90% (Folio >> A4), 86% (A4 >> B5), 70% (A4 >> A5)
Metric Models	Standard	100%, 400% (Max.), 200%, 141% (A5 >> A4), 115% (B5 >> A4), 86% (A4 >> B5), 70% (A4 >> A5), 50%, 25% (Min.)
	Other	129% (Statement >> Letter), 90% (Folio >> A4), 78% (Legal >> Letter), 64% (Letter >> Statement)

Model	Zoom Level (OriginalCopy)	
Metric Models (Asia Pacific)	Standard	100%, 400% (Max.), 200%, 141% (A5 >> A4), 115% (B5 >> A4), 90% (Folio >> A4), 86% (A4 >> B5), 70% (A4 >> A5), 50%, 25% (Min.)
	Other	129% (Statement >> Letter), 78% (Legal >> Letter), 64% (Letter >> Statement)

The procedure for using zoom copying is explained below.

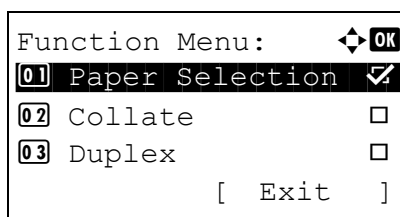

- 1 Press the **Function Menu** key. Function Menu appears.

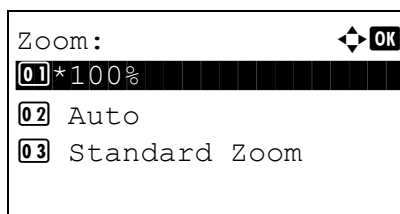

- 2 Press the Δ or ∇ key to select [Zoom].
- 3 Press the **OK** key. Zoom appears.

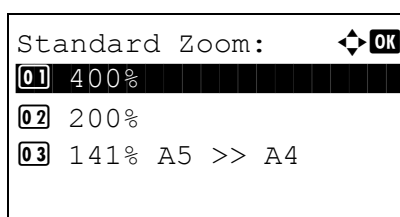

- 4 Press the Δ or ∇ key to select the desired magnification.

To copy in the same size as the original, select [100%].

To select automatic zoom, select [Auto].

To use fixed magnifications, select [Standard Zoom] and press the **OK** key. Standard Zoom appears. Press the Δ or ∇ key to select the desired magnification. If you select [Other] and press the **OK** key, you can select from additional magnifications.

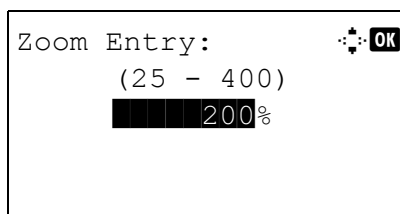

To enter a magnification, select [Zoom Entry] and press the **OK** key. Zoom Entry appears. Use the numeric keys to enter the any magnification.

- 5 Press the **OK** key. *Completed.* is displayed and the screen returns to the basic screen.
- 6 Press the **Start** key. Copying begins.

Duplex Copying

Produce two-sided copies. The following duplex options are available.

You can also create single-sided copies from two-sided originals or originals with facing pages such as books. The following modes are available.

One-sided to Two-sided

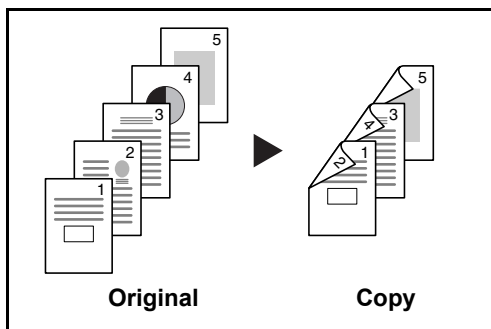

Produces two-sided copies from one-sided originals. In case of an odd number of originals, the back side of the last copy will be blank.

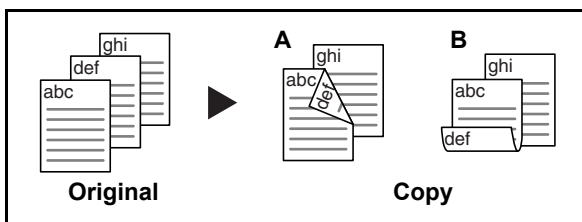

The following binding options are available.

- A Original Left/Right to *Binding Left/Right*: Images on the second sides are not rotated.
- B Original Left/Right to *Binding Top*: Images on the second sides are rotated 180°. Copies can be bound on the top edge, facing the same orientation when turning the pages.

Two-sided to One-sided

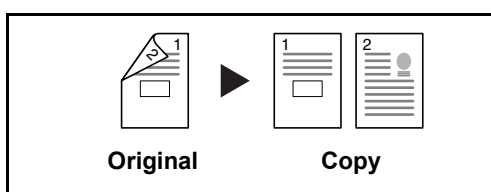

Copies each side of a two-sided original onto two individual sheets. The optional document processor is required.

The following binding options are available.

- *Binding Left/Right*: Images on the second sides are not rotated.
- *Binding Top*: Images on the second sides are rotated 180°.

Two-sided to Two-sided

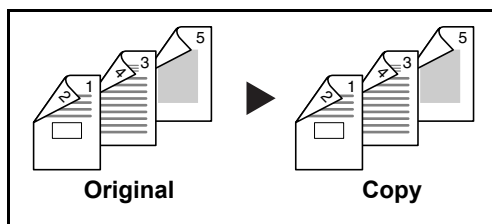

Produces two-sided copies from two-sided originals. The optional document processor is required.

NOTE: The paper sizes supported in Two-sided to Two-sided are Legal, Letter, Oficio II, Executive, A4, B5, A5 and Folio.

The procedure for using two-sided/duplex copying is explained below.

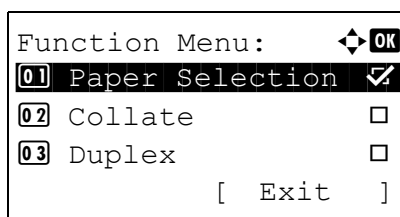

1 Press the **Function Menu** key. Function Menu appears.

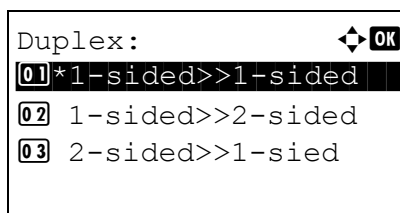

2 Press the Δ or ∇ key to select [Duplex].

3 Press the **OK** key. Duplex appears.

4 Press the Δ or ∇ key to select the desired duplex copying mode.

NOTE: [2-sided>>1-sided] and [2-sided>>2-sided] are shown only when the optional document processor (DP-110) is installed.

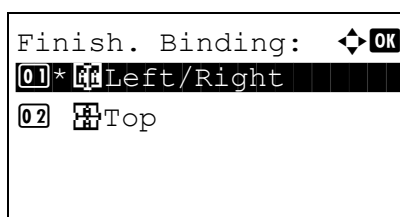

If you select [1-sided>>2-sided], press [Detail] (the **Right Select** key) and you can select the binding edge of the finished copies and the original setting orientation.

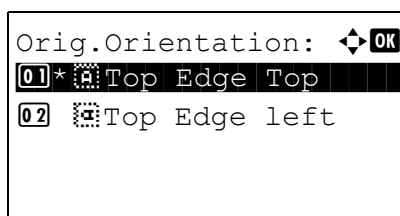

After pressing the **OK** key, select the binding edge of the finished copies and the original setting orientation.

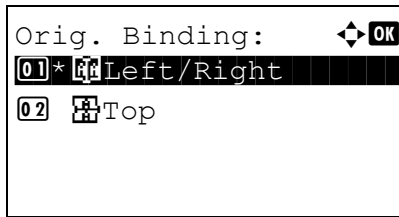

If you select [2-sided>>1-sided], press [Detail] (the **Right Select** key) and you can select the binding edge of the original and the original setting orientation.

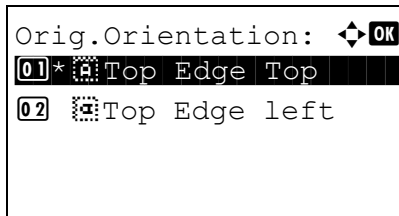

After pressing the **OK** key, select the binding edge of the original and finished copies, and the original setting orientation.

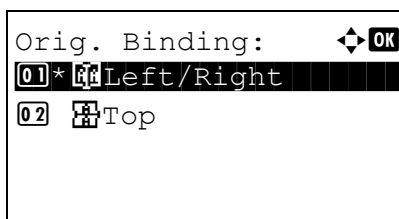

If you select [2-sided>>2-sided], press [Detail] (the **Right Select** key) and you can select the binding edge of the original and the original setting orientation.

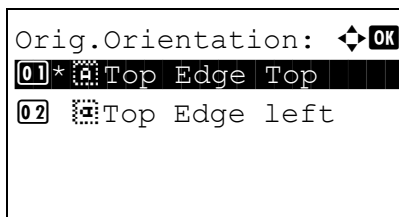

After pressing the **OK** key, select the binding edge of the finished copies and the original setting orientation.

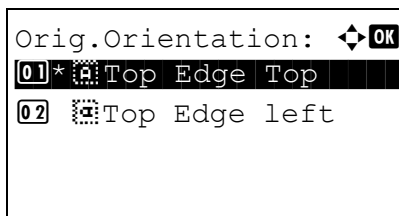

After pressing the **OK** key, select the binding edge of the original and finished copies, and the original setting orientation.

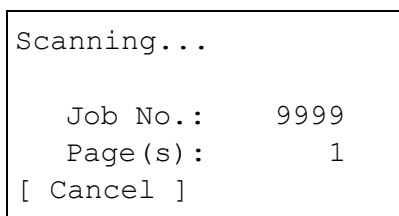

- 5 Press the **OK** key. *Completed.* is displayed and the screen returns to the basic screen.
- 6 Press the **Start** key. Copying begins.

If the original is placed on the platen, replace it with the next one before pressing the **Start** key.

```

Set original
and press Start key.
  Job No.:    9999
  Page(s):    3
[ Cancel ] [End Scan]

```

If there is no next original, press [End Scan] (the **Right Select** key). Copying begins.

Collate Copying

The machine can collate at the same time as it copies.

You can use the Collate copy function for tasks such as those shown below.

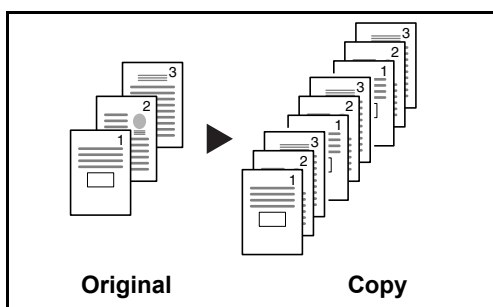

Scan multiple originals and deliver complete sets of copies as required according to page number.

```

Function Menu:  ⬇ OK
01 Paper Selection  ✓
02 Collate         □
03 Duplex         □
                [ Exit ]

```

```

Collate:      ⬇ OK
01 Off
02*On

```

The procedure for using collate copying is explained below.

- 1 Press the **Function Menu** key. Function Menu appears.
- 2 Press the Δ or ∇ key to select [Collate].
- 3 Press the **OK** key. Collate appears.
- 4 Press the Δ or ∇ key to select [Off] or [On].
- 5 Press the **OK** key. *Completed.* is displayed and the screen returns to the basic screen.
- 6 Press the **Start** key Copying begins.

Printing - Printing from Applications

Follow the steps below to print documents from applications.

NOTE: To print the document from applications, install the printer driver on your computer from the supplied CD-ROM (Product Library).

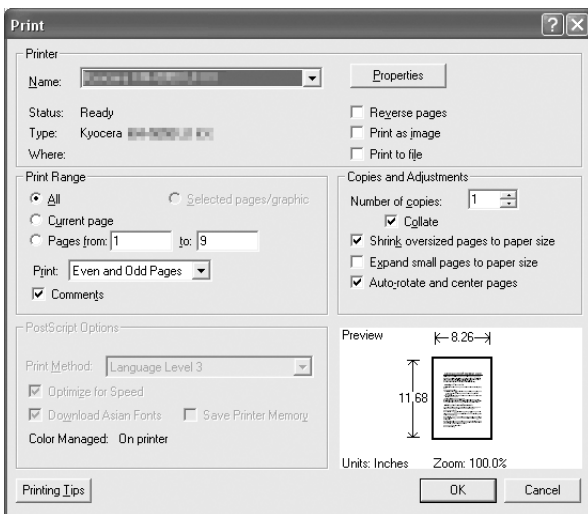

- 1 Create a document using an application.
- 2 Click **File** and select **Print** in the application. The **Print** dialog box appears.
- 3 Click the ▼ button next to the Name field and select this machine from the list.

- 4 Enter the desired print quantity in the **Number of copies** box. Enter any number up to 999.

When there is more than one document, select **Collate** to print out one by one in the sequence of the page numbers.

- 5 Click **Properties** button. The **Properties** dialog box appears.

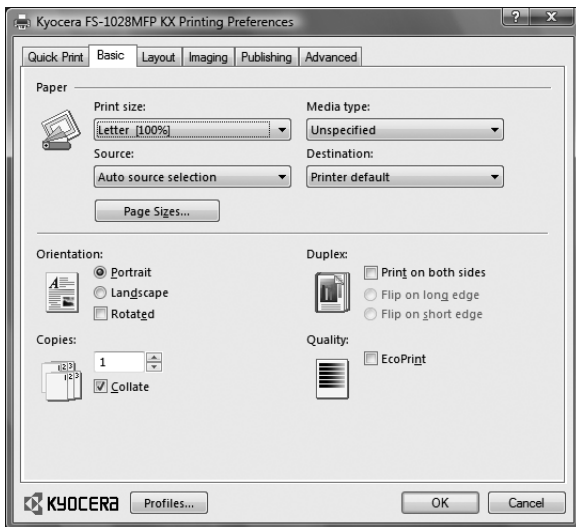

- 6 Select the **Basic** tab and click **Page Size** button to select the paper size.

To print on the special paper such as thick paper or transparency, click the **Media Type** menu and select the media type.

- 7 Click **Source** and select the paper source.

NOTE: If you choose **Auto Select**, papers are supplied automatically from the paper source loaded with paper of optimum size and type. To print on special paper such as envelope or thick paper, place it on the multi purpose tray and select **MP Tray**.

- 8 Select paper orientation, either **Portrait** or **Landscape**, to match the orientation of the document.

Selecting **Rotate 180°** will print the document rotated 180°.

- 9 Click **OK** button to return to the **Print** dialog box.
- 10 Click **OK** button to start printing.

Sending

This machine can send a scanned image as an attachment to an E-mail message or to a PC linked to the network. In order to do this, it is necessary to register the sender and destination (recipient) address on the network.

A network environment which enables the machine to connect to a mail server is required. It is recommended that a Local Area Network (LAN) be used to assist with transmission speed and security issues.

At the same time as you send a scanned image, you can also print the image or send it to the Document Box.

To use the Scanning Function perform the following steps:

- Program the settings, including the E-mail setting on the machine.
- Use COMMAND CENTER (the internal HTML web page) to register the IP address, the host name of the SMTP server, and the recipient.
- Register the destination in the Address Book or One-touch keys.
- When the PC Folder (SMB/FTP) is selected, it is necessary to share the destination folder. For setting-up the PC Folder, contact your administrator.
- Detailed transmission settings (to select a Document Box as the destination or to print and send the image at the same time)

Follow the steps below for basic sending. The following four options are available.

- Send as E-mail: Sends a scanned original image as an E-mail attachment...page 3-21
- Send to Folder (SMB): Stores a scanned original image in a shared folder of any PC...page 3-23
- Send to Folder (FTP): Stores a scanned original image in a folder of an FTP server...page 3-23
- Image Data Scanning with TWAIN / WIA: Loads the document data stored in a Custom Box to a PC...Refer to the *TWAIN/WIA Driver Operation Guide*

NOTE: Different sending options can be specified in combination. Refer to *Sending to Different Types of Destinations (Multi Sending)* on page 3-30.

Send as E-mail

Sends a scanned original image as an E-mail attachment.

NOTE:

- You must have a network environment in which this machine can connect to a mail server. It is recommended that the machine be used in an environment in which it can connect to the mail server at any time over a LAN.
- Access the COMMAND CENTER beforehand and specify the settings required for sending e-mail. For details, see *COMMAND CENTER (Settings for E-mail)* on page 2-25.
- Refer to *Character Entry Method on Appendix-5* for details on entering characters.

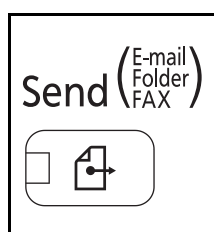

- 1 Press the **Send** key.
Displays the screen for sending.

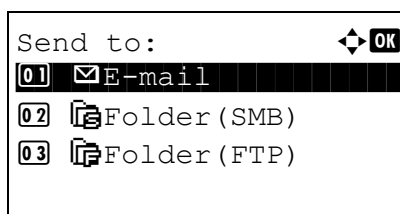

- 2 Press the Δ or ∇ key to select [E-mail].

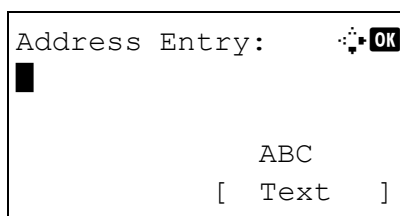

- 3 Press the **OK** key. Address Entry appears.

- 4 Enter the destination e-mail address.

NOTE: Destination can be specified using the Address Book or the One-touch keys. Refer to *Specifying Destination* on page 3-28.

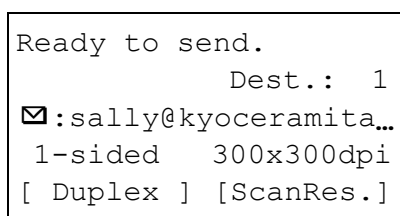

- 5 Press the **OK** key. *Completed.* is displayed and the screen returns to the basic screen.

NOTE: If the screen for confirming the entry of a new destination (*page 8-64*) is set to [On], a screen to confirm the entered e-mail address appears. Enter the same e-mail address again and press the **OK** key.

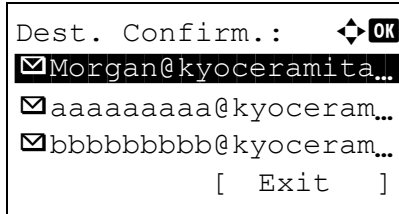

6 If there are additional destinations, press the **Add Destination** key. Repeat steps 2 to 5 to enter additional destinations. Up to 100 destinations can be specified.

7 Press the **Confirm Destination** key to confirm the registered destinations.

Press the Δ or ∇ key to select a destination and press the **OK** key. Then, you can edit or delete the destination.

Press [Exit] (the **Right Select** key) to return to the basic screen.

8 Press the **Start** key. Transmission starts.

NOTE: If the screen for confirming the destination before transmission (*page 8-64*) is set to [On], the Confirm Destination screen appears when the **Start** key is pressed. For more information, refer to *Confirm Destination Screen* on *page 3-27*.

Send to Folder (SMB)/Send to Folder (FTP)

Stores a scanned original image file in the specified shared folder of any PC.

Stores a scanned original image in a folder of an FTP server.

NOTE:

- Refer to Help of your operating system for details on how to share a folder.
- Be sure that **SMB Protocol** or **FTP** in the COMMAND CENTER is *On*. For details, refer to the *KYOCERA COMMAND CENTER Operation Guide*.
- Refer to *Character Entry Method on Appendix-5* for details on entering characters.

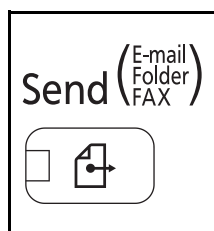

- 1 Press the **Send** key.
Displays the screen for sending.

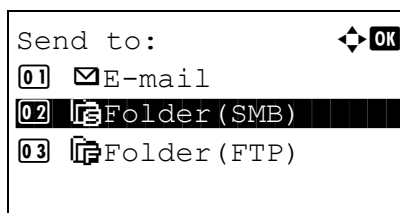

- 2 Press the Δ or ∇ key to select [Folder(SMB)] or [Folder(FTP)].

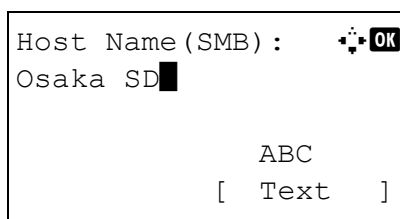

- 3 Press the **OK** key. Host Name(SMB) or Host Name(FTP) appears.

- 4 Enter the host name.

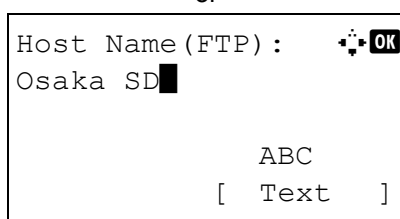

- 5 Press the **OK** key. Path appears.

NOTE: Destination can be specified using the Address Book or the One-touch keys. Refer to *Specifying Destination on page 3-28*.

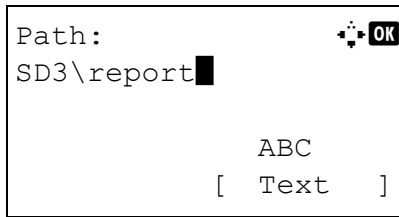

6 Enter the path name. Consider, that the share name but not the foldername on the destination pc has to be typed in.

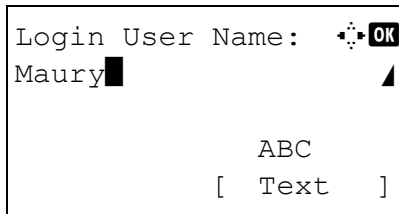

7 Press the **OK** key. Login User Name appears.

8 Enter the login user name. You have to enter the account name of the destination pc.

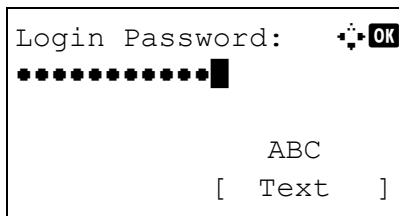

9 Press the **OK** key. Login Password appears.

10 Enter the login password (account on the destination pc.)

11 Press the **OK** key. A confirmation screen appears.

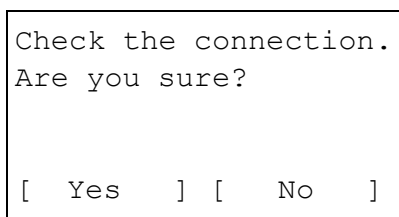

NOTE: If the screen for confirming the entry of a new destination (*page 8-64*) is set to [On], screens to confirm the entered host name and path name appear. Enter the same host name and path name again and press the **OK** key on their respective screens.

Data to be entered are as follows.

NOTE: You will be unable to send the data if you forget your login user name or login password. Contact your administrator and check your login user name or login password.

For send to folder (SMB)

Item	Data to be entered	Max. characters
Host Name (SMB)*	Host name or IP address of the PC to receive the data.	Up to 64 characters
Path	Path to the receiving folder such as follows. For example, <i>User\Sharename</i> .	Up to 128 characters
Login User Name	User name to access the PC For example, <i>abcdnet\james.smith</i>	Up to 64 characters
Login Password	Password to access the PC	Up to 64 characters

* To specify a port number different from the default (139), enter using the format "host name: port number" (e.g., SMBhostname: 140).

For send to folder (FTP)

Item	Data to be entered	Max. characters
Host Name (FTP)*	Host name or IP address of FTP server	Up to 64 characters
Path	Path to the receiving folder. For example, <i>User\ScanData</i> . Otherwise the data will be saved in the home directory.	Up to 128 characters
Login User Name	FTP server log-in user name	Up to 64 characters
Login Password	FTP server log-in password	Up to 64 characters

* To specify a port number different from the default (21), enter using the format "host name: port number" (e.g., FTPhostname: 140).

```

Dest. Confirm.:  [OK]
[M]Morgan@kyoceramita...
[+]0667640000
[+]0667741234
[ Exit ]

```

- 12** Press [Yes] (the **Left Select** key). This makes a connection with the entered destination.

If the connection is successful, *Connected.* is displayed on the screen. Press [OK] (the **Right Select** key). *Completed.* is displayed and the screen returns to the basic screen.

If the connection failed, *Cannot connect.* is displayed. Press [OK] (the **Right Select** key). The screen shown in step 3 reappears. Check and re-enter the destination.

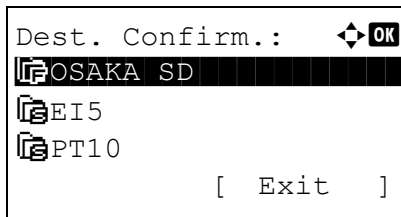

13 If there are additional destinations, press the **Add Destination** key. Repeat steps 2 to 12 to enter additional destinations. Up to 100 destinations can be specified.

14 Press the **Confirm Destination** key to confirm the registered destinations.

Press the Δ or ∇ key to select a destination and press the **OK** key. Then, you can edit or delete the destination.

Press [Exit] (the **Right Select** key) to return to the basic screen.

15 Press the **Start** key. Transmission starts.

NOTE: If the screen for confirming the destination before transmission (page 8-64) is set to [On], the Confirm Destination screen appears when the **Start** key is pressed. For more information, refer to *Confirm Destination Screen* on page 3-27.

Confirm Destination Screen

If the screen for confirming the destination before transmission (page 8-64) is set to [On], *Check through the all destination and press [Next]*. appears when the **Start** key is pressed.

Use the procedure below to operate the Confirm Destination screen.

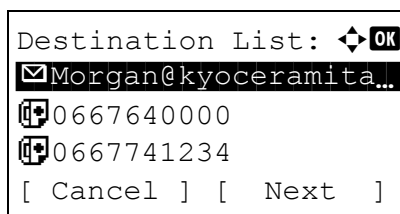

- 1 Press the Δ or ∇ key to check all destinations.

Press the **OK** key to edit or delete the selected destination.

To add a destination, press [Cancel] (the Left Select key) to return to the previous screen.

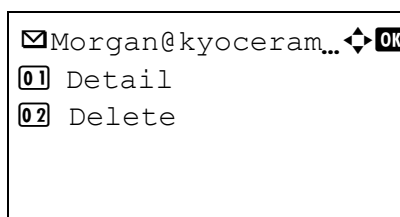

- 2 After the checking is finished, press [Next] (the **Right Select** key). *Set original and press Start key.* is displayed on the screen.

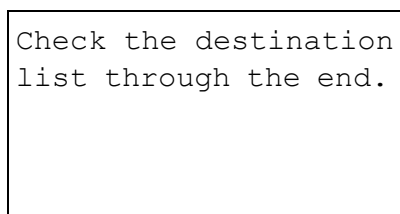
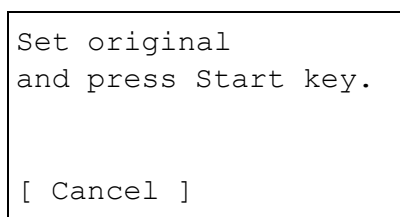

If there are destinations that are hidden and not yet checked, the screen displays *Check the destination list through the end.* and returns to the Destination List screen. Check all destinations.

- 3 Place the original on the platen and press the **Start** key. Transmission starts.

Specifying Destination

When specifying destination, choose from the Address Book or use the One-touch keys.

Choosing from the Address Book

Select a destination registered in the Address Book.

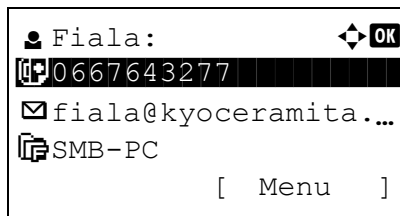
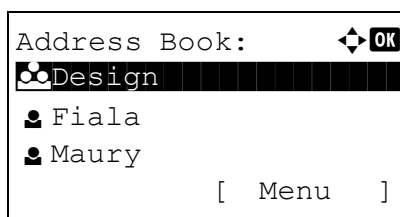
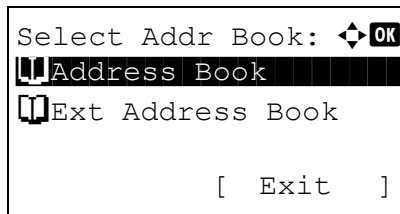

1 In the basic screen for sending, press the **Address Book** key. The Select Addr Book menu appears.

2 Press the Δ or ∇ key to select [Address Book] and then press the **OK** key. Address Book appears.

To use an address book on the LDAP server, select [Ext Address Book].

NOTE: If external address book is not registered, [Ext Address Book] is not displayed.

3 Press the Δ or ∇ key to select the desired user or group, and then press the **OK** key.

If you select a user, the list of destinations registered to the user appears.

If you select a group, proceed to step 5.

4 Press the Δ or ∇ key to select the desired destination and then press the **OK** key.

5 *Completed.* is displayed and the screen returns to the basic screen.

Destination Search

Destinations registered in the Address Book can be searched.

The procedures for using the different search modes are explained below.

Search in Address Book

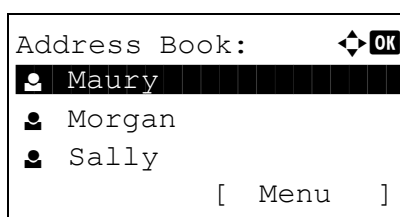
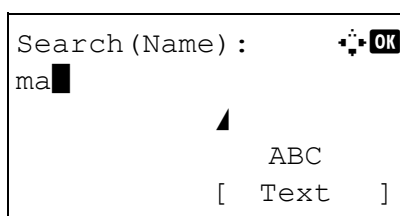
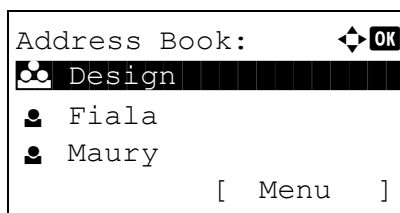
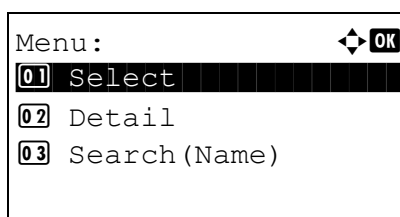

- 1 In Address Book, press [Menu] (the **Right Select** key). Menu appears.
- 2 Press the Δ or ∇ key to select [Search(Name)] and then press the **OK** key. A search screen appears.
- 3 Enter the characters you want to search.
- 4 Press the **OK** key. The address book appears with the user that starts with the entered character string at the top.

3

Search in External Address Book

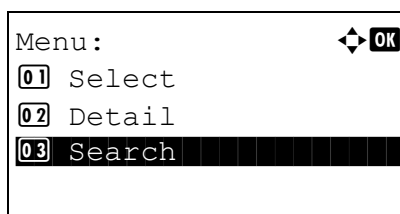
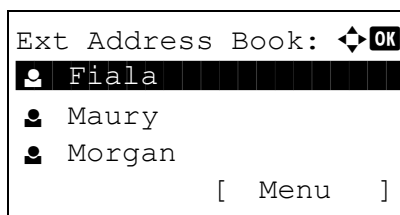

- 1 In Ext Address Book, press [Menu] (the **Right Select** key). Menu appears.
- 2 Press the Δ or ∇ key to select [Search] and then press the **OK** key. A search screen appears.

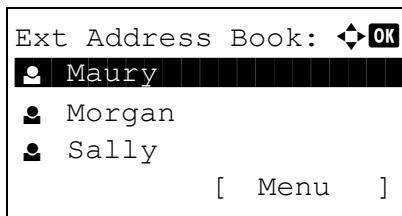
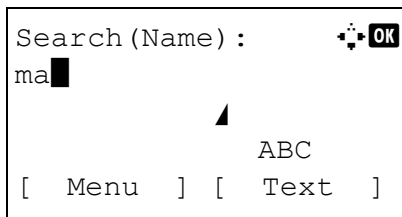

- 3 Enter the characters you want to search.
If you press [Menu] (the **Right Select** key) and then the **OK** key, Search by appears where you can specify the search key and match condition. Select the desired item for each and then press the **OK** key.
- 4 Press the **OK** key. The address book appears with the user that starts with the entered character string at the top.

NOTE: If you first open the extended address book, the search screen appears first. Then, operate from step 3.

Choosing by One-Touch Key

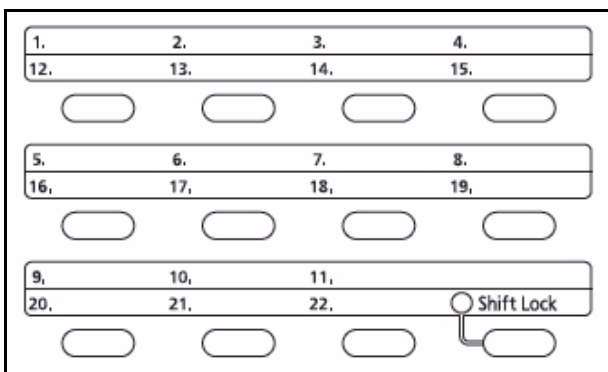

Select the destination using the One-touch keys.
In the basic screen for sending or the destination entry screen, press the one-touch key where the destination is registered.

NOTE: Refer to *Adding a Destination on One-touch Key* on page 8-124 for more information on adding one-touch keys.

Sending to Different Types of Destinations (Multi Sending)

You can specify destinations that combine e-mail addresses, folders (SMB or FTP) and fax numbers. This is referred to as *Multi Sending*. This is useful for sending to different types of destination (e-mail addresses, folders, etc.) in a single operation.

No. of broadcast items	E-mail	: Up to 100
	Folders (SMP, FTP)	: Total of 1 SMB and FTP
	FAX	: Up to 100

Also, depending on the settings, you can send and print at the same time.

Procedures are the same as used in specifying the destinations of respective types. Continue to enter E-mail address or folder path so that they appear in the destination list. Press the **Start** key to launch transmission to all destinations at one time.

Canceling Jobs

Follow the steps below to cancel any print or send job being executed.

Canceling Jobs

You can also cancel jobs by pressing the **Stop** key.

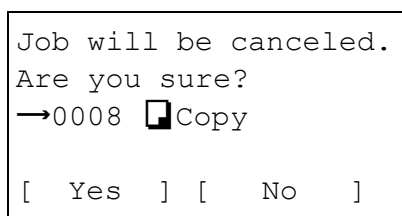
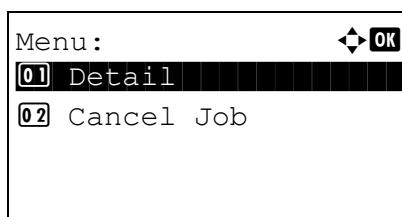
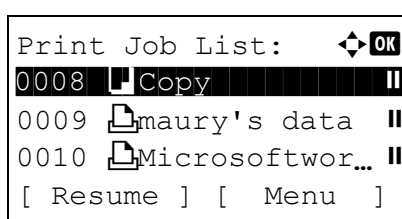
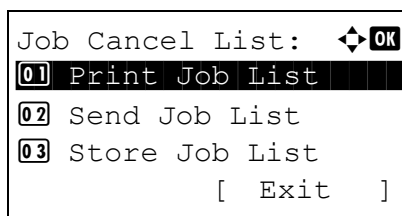

- 1 During a printing or sending job, press the **Stop** key. The Job Cancel List menu appears.

NOTE: Pressing the **Stop** key pauses a printing job but does not pause a sending job.

- 2 Press the Δ or ∇ key to select the type of job you want to stop, and then press the **OK** key. An output queue of the selected job type is displayed.
- 3 Press the Δ or ∇ key to select the job you want to stop, and then press [Menu] (the **Right Select** key). Menu appears.
- 4 Press the Δ or ∇ key to select [Cancel Job] and then press the **OK** key. A confirmation screen appears.
- 5 Press [Yes] (the **Right Select** key). The screen displays *Canceling....* and returns to the output queue of the selected job type after the job is canceled.

To cancel other jobs, repeat steps 3 to 5.

Checking Remaining Toner and Paper

You can check the remaining amount of toner and that of paper in each feeder cassette.

Checking Remaining Toner

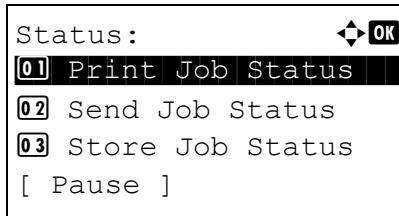

1 Press the **Status/Job Cancel** key. The Status menu appears.

2 Press the Δ or ∇ key to select [Toner Status].

3 Press the **OK** key. Toner Status appears.

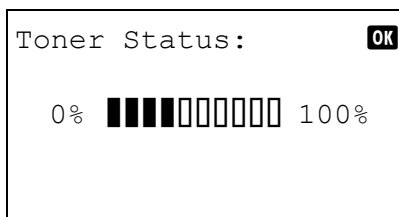

The remaining amount of toner is displayed in one of 10 levels.

Checking Remaining Paper

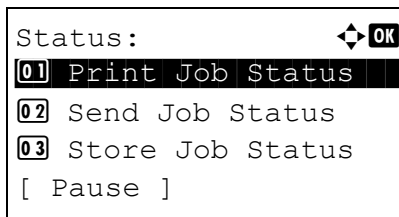

1 Press the **Status/Job Cancel** key. The Status menu appears.

2 Press the Δ or ∇ key to select [Paper Status].

3 Press the **OK** key. Paper Status appears.

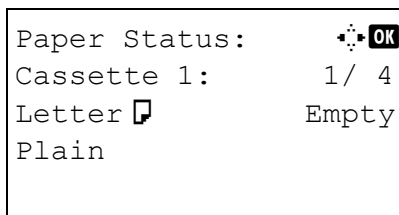

Press the \triangleleft or \triangleright key to switch the display of remaining paper amount among the main unit cassette, optional cassette (if installed) and MP tray.

Program (Copying and Sending)

Settings of various functions frequently used for copying and sending can be collectively registered as a program. Then, you can change the current settings of various functions to the registered settings by just pressing one of the **Program 1 to 4** keys.

Registering Settings

```
Registered.
→Program 1
```

After making settings, press and hold the one of the **Program 1 to 4** keys where you want to register the settings for 3 seconds. The current settings are registered to the selected program key.

3

Changing and Deleting Settings

```
Menu: ◀ ▶ OK
[01] Overwrite
[02] Delete
```

1 Press and hold the one of the **Program 1 to 4** keys where the settings you want to change/delete are registered for 3 seconds. Menu appears.

```
Overwrite.
Are you sure?
→Program 1
[ Yes ] [ No ]
```

2 To replace the registered settings with the current settings, press the Δ or ∇ key to select [Overwrite] and then press the **OK** key. A confirmation screen appears. Press [Yes] (the **Left Select** key) to change the settings.

```
Delete.
Are you sure?
→Program 1
[ Yes ] [ No ]
```

To delete the registered settings, press the Δ or ∇ key to select [Delete] and then press the **OK** key. A confirmation screen appears. Press [Yes] (the **Left Select** key) to delete the registered settings.

Recalling Settings

Press the one of the **Program 1 to 4** keys where the settings you want to recall are registered. The current settings of various functions are replaced with the registered settings.

4 Copying Functions

This chapter explains the functions available for copying.

- Original Size..... 4-2
- Paper Selection..... 4-4
- Original Orientation 4-8
- EcoPrint 4-10
- Combine Mode..... 4-11
- Continuous Scan..... 4-15
- Job Finish Notice 4-16
- File Name Entry 4-18
- Print Override..... 4-19

Original Size

Specify the size of originals being scanned. Be sure to select the original size before starting the copying process.

The following options are available.

Item	How to Select	Sizes
Standard Sizes	Select from standard sizes.	Letter, Legal, Statement, Executive, Officio II, A4, A5, A6, B5, B6, Folio, 16K
Others	Select from envelope, postcard or the custom sized originals*.	ISO B5, Envelope #10, Envelope #9, Envelope #6, Envelope Monarch, Envelope DL, Envelope C5, Hagaki, Oufuku Hagaki, Youkei 4, Youkei 2 and Custom

* For instructions on how to specify the custom original size, refer to *Custom Original Size Setup on page 8-8*.

Use the procedure below to select the original size.

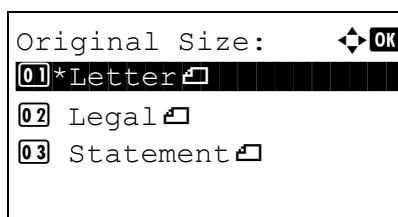
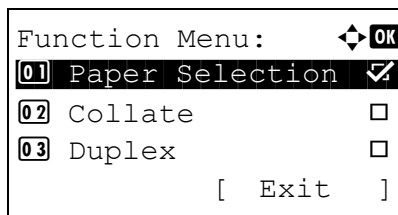

- 1 Press the **Copy** key.
- 2 Place the originals on the platen.
- 3 Press the **Function Menu** key. Function Menu appears.
- 4 Press the Δ or ∇ key to select [Original Size].
- 5 Press the **OK** key. Original Size appears.
- 6 Press the Δ or ∇ key to select the desired original size and then press the **OK** key.

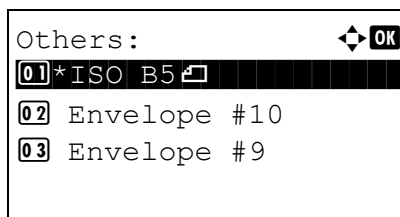

If you select [Others], select one of the other options and then press the **OK** key.

Completed. is displayed and the screen returns to the basic screen for copying.

- 7 Press the **Start** key to start copying.

4

Paper Selection

Select the paper source that contains the required paper size.

NOTE: Specify in advance the size and type of the paper loaded in the cassette (refer to *Original/Paper Settings* on page 8-8).

Selecting the Cassette

Use the procedure below to select the paper supply cassette.

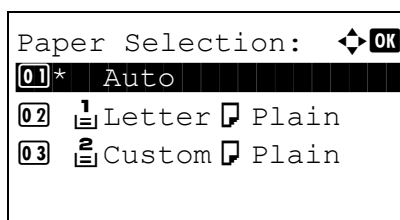
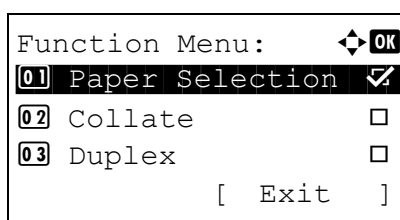

- 1 Press the **Copy** key.
- 2 Place the originals on the platen.
- 3 Press the **Function Menu** key. Function Menu appears.
- 4 Press the Δ or ∇ key to select [Paper Selection].
- 5 Press the **OK** key. Paper Selection appears.
- 6 Press the Δ or ∇ key to select the desired paper size.

If [Auto] is selected, the paper matching the size of the original is selected automatically.
- 7 Press the **OK** key.

Completed. is displayed and the screen returns to the basic screen for copying.
- 8 Press the **Start** key to start copying.

Selecting the Multi Purpose Tray

Change the paper size and media type.

The available paper sizes and media types are shown in the table below.

Category	Item	How to Select	Sizes
Paper Size	Standard Sizes	Select from the standard size.	Letter, Legal, Statement, Executive, Oficio II, A4, A5, A6, B5, B6, Folio and 16K
	Others	Select from envelope, postcard or the custom sized originals	ISO B5, Envelope #10, Envelope #9, Envelope #6, Envelope Monarch, Envelope DL, Envelope C5, Hagaki, Oufuku Hagaki, Youkei 4, Youkei 2 and Custom
	Size Entry	Enter the size not included in the standard sizes 1 and 2**.	Inch models Horizontal: 5.83 to 14.02" (in 0.01" increments), Vertical: 2.76 to 8.50" (in 0.01" increments) Metric models Vertical: 70 to 216 mm (in 1 mm increments), Horizontal: 148 to 356 mm (in 1 mm increments)
Media Type	Plain, Transparency, Rough, Vellum, Labels, Recycled, Preprinted***, Bond, Cardstock, Color, Prepunched***, Letterhead***, Envelope, Thick, High Quality, Custom 1 to 8***		

* For instructions on how to specify the custom paper size (Custom), refer to *Adding a Custom Size and Media Type for Paper to Print on page 8-11*.

** The input units can be changed in the System menu. Refer to *Switching Unit of Measurement on page 8-27*.

*** For instructions on how to specify the custom paper types 1 to 8, refer to *Paper Weight on page 8-17*.
To print on preprinted or prepunched paper or on letterhead, refer to *Special Paper Action on page 8-24*.

NOTE: You can conveniently select in advance the size and type of paper that will be used often and set them as default (refer to *Paper Size and Media Type Setup for Multi Purpose Tray on page 8-15*).

Use the procedure below to select the paper size and media type.

- 1** Press the **Copy** key.
- 2** Place the originals on the platen.

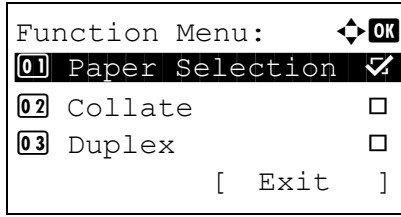

3 Press the **Function Menu** key. Function Menu appears.

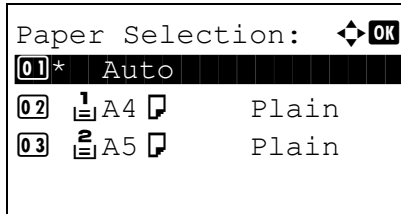

4 Press the Δ or ∇ key to select [Paper Selection].

5 Press the **OK** key. Paper Selection appears.

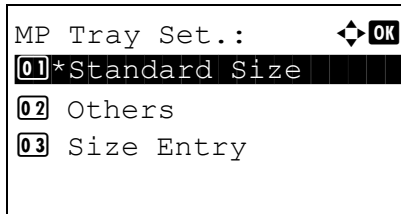

6 Press the Δ or ∇ key to select [MP Tray Set.].

7 Press the **OK** key. MP Tray Set. appears.

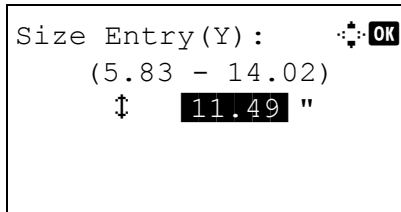

8 Press the Δ or ∇ key to select [Standard Size], [Others] or [Size Entry] and press the **OK** key, select the desired paper size, and then press the **OK** key.

If you select [Size Entry], using the numeric keys to enter the Y (vertical) size and press the **OK** key, and then enter the X (horizontal) size and press the **OK** key.

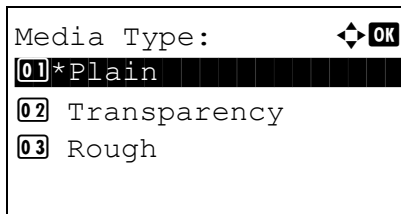

9 Press the Δ or ∇ key to select the desired paper type and then press the **OK** key.

Completed. is displayed and the screen returns to the basic screen for copying.

10 Place paper in the multi purpose tray.

11 Press the **Start** key to start copying.

If Add paper in MP tray. is displayed during the copying process, add paper in the multi purpose tray, and then press the **OK** key. Copying then resumes.

Original Orientation

Select the original orientation to use the following functions.

- Duplex
- Combine mode

When placing originals on the platen

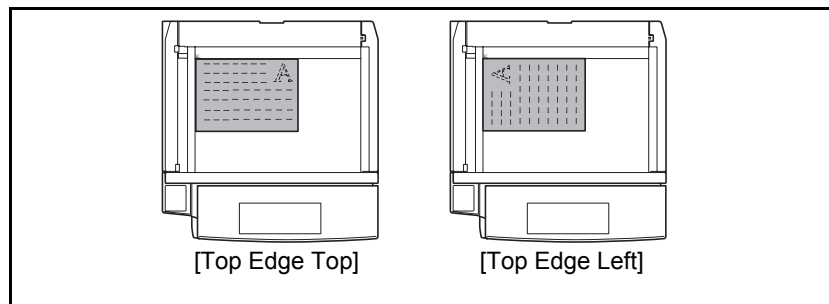

When placing originals on the optional document processor

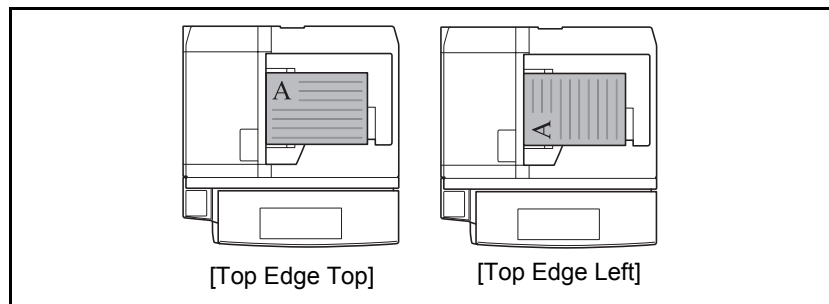

NOTE: To change the default setting for the original orientation, refer to *Orig.Orientation* on page 8-30.

Use the procedure below to select the orientation when placing the originals on the platen.

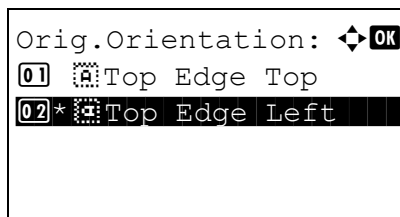
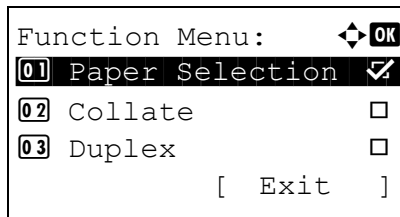

- 1 Press the **Copy** key.
- 2 Place the originals on the platen.
- 3 Press the **Function Menu** key. Function Menu appears.
- 4 Press the Δ or ∇ key to select [Orig.Orientation].
- 5 Press the **OK** key. Orig.Orientation appears.
- 6 Press the Δ or ∇ key to select [Top Edge Top] or [Top Edge Left].
- 7 Press the **OK** key.
Completed. is displayed and the screen returns to the basic screen for copying.
- 8 Press the **Start** key to start copying.

EcoPrint

Use EcoPrint to save toner when printing. Use this function for test copies or any other occasion where high quality print is unnecessary.

The procedure for making copies using EcoPrint is explained below.

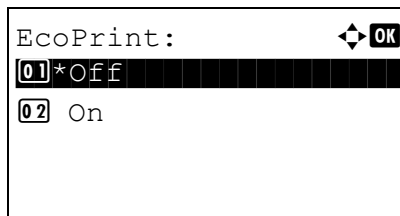
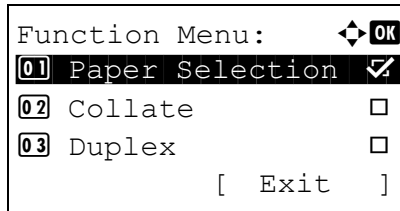

- 1 Press the **Copy** key.
- 2 Place the originals on the platen.
- 3 Press the **Function Menu** key. Function Menu appears.
- 4 Press the Δ or ∇ key to select [EcoPrint].
- 5 Press the **OK** key. EcoPrint appears.
- 6 Press the Δ or ∇ key to select [On] and then press the **OK** key.
Completed. is displayed and the screen returns to the basic screen for copying.
- 7 Press the **Start** key to start copying.

Combine Mode

This mode allows you to copy 2 or 4 originals combined onto a single page. 2-in-1 mode or 4-in-1 mode. The page boundary of each original can be indicated.

NOTE: Combine mode is available for the copy paper sizes of Folio, A4, B5, Legal, Oficio II, Letter, Statement and 16K.

2-in-1 Mode

For copying two originals onto a single sheet. This mode can be used with Duplex mode to copy four originals onto one sheet.

The following 2-in-1 options and output orientations are available.

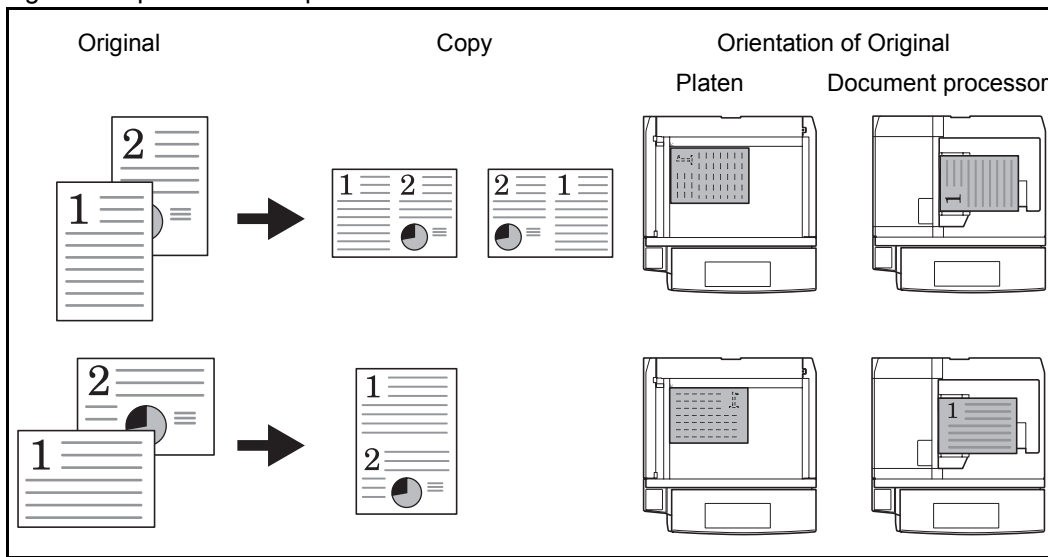

NOTE: When placing the original on the platen, be sure to copy the originals in page order.

4-in-1 Mode

For copying four originals onto a single sheet. This mode can be used with Duplex mode to copy eight originals onto one sheet.

The following 4-in-1 options and output orientations are available.

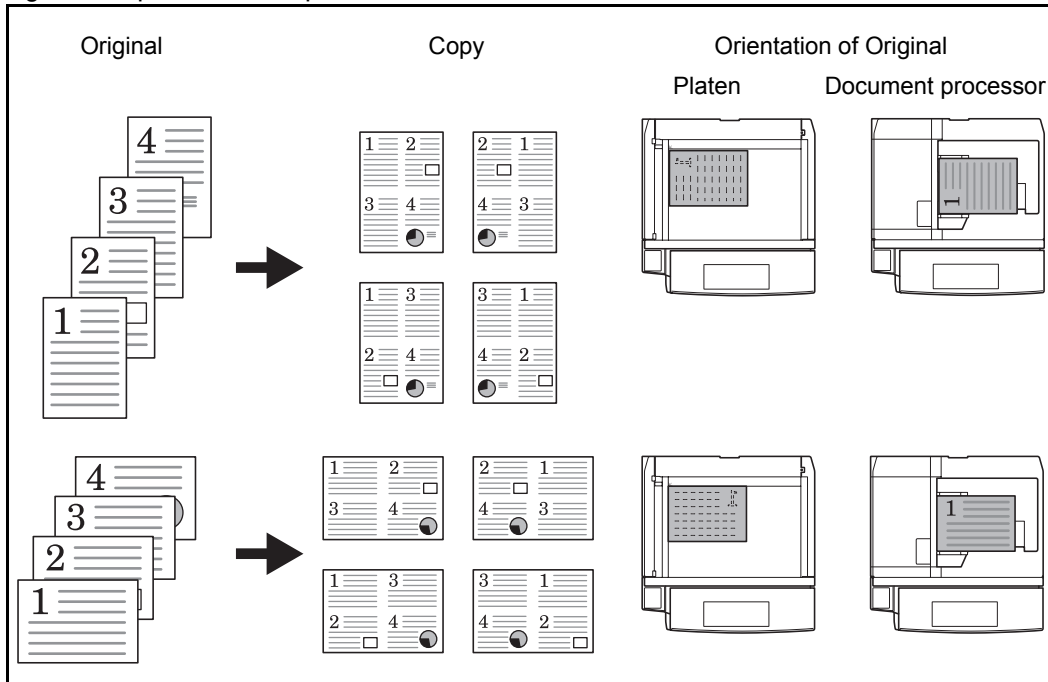

NOTE: When placing the original on the platen, be sure to copy the originals in page order.

Types of Page Boundary Lines

The following types of the boundary lines are available.

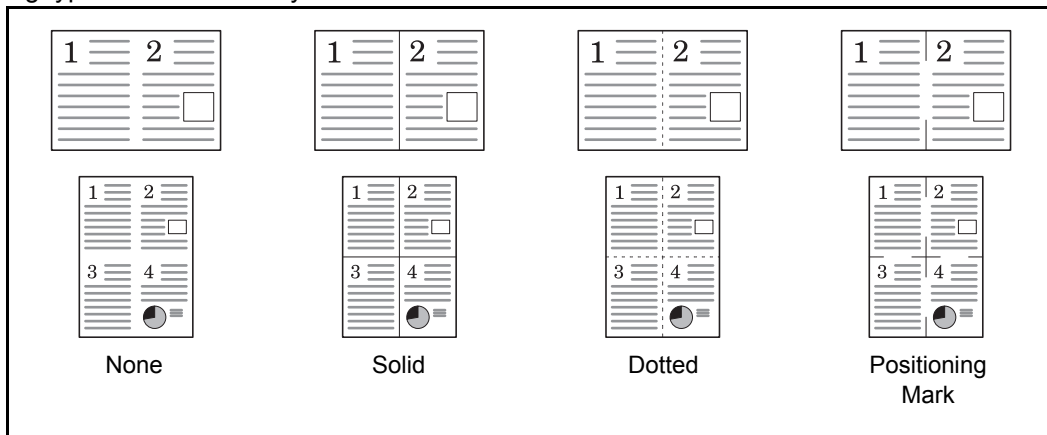

The procedure for using Combine mode copying is explained below.

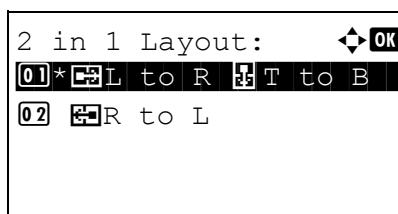
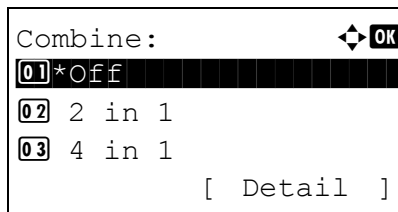
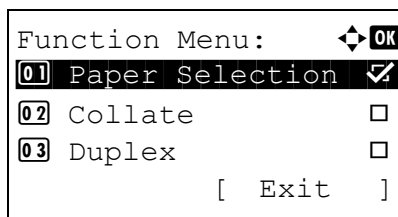

- 1 Press the **Copy** key.
- 2 Place the originals on the platen.
- 3 Press the **Function Menu** key. Function Menu appears.
- 4 Press the Δ or ∇ key to select [Combine].
- 5 Press the **OK** key. Combine appears.
- 6 Press the Δ or ∇ key to select [2 in1] or [4 in 1].
- 7 Press [Detail] (the **Right Select** key).
- 8 Press the Δ or ∇ key to select the desired layout and then press the **OK** key.

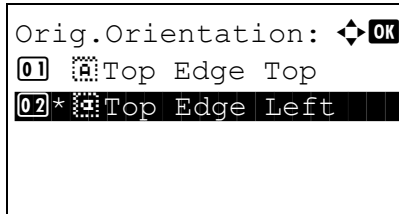
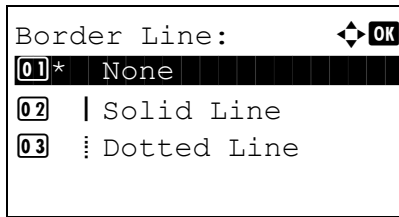

9 Press the Δ or ∇ key to select the desired border line type and then press the **OK** key.

10 Press the Δ or ∇ key to select the orientation of the original and then press the **OK** key.

Completed. is displayed and the screen returns to the basic screen for copying.

11 Press the **Start** key. Scanning begins.

If the original is placed on the platen, replace the original and press the **Start** key.

After scanning all originals, press [End Scan] (the **Right Select** key) to start copying.

Continuous Scan

When a large number of originals cannot be placed in the document processor at one time, the originals can be scanned in separate batches and then copied as one job. With this function, originals are scanned until you press [End Scan] (the **Right Select** key).

The procedure for making copies using Continuous Scan is explained below.

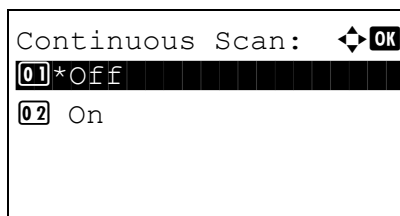
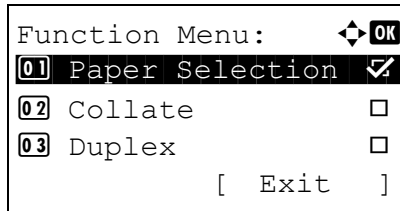

- 1 Press the **Copy** key.
 - 2 Press the **Function Menu** key. Function Menu appears.
 - 3 Press the Δ or ∇ key to select [Continuous Scan].
 - 4 Press the **OK** key. Continuous Scan appears.
 - 5 Press the Δ or ∇ key to select [On] and then press the **OK** key.
Completed. is displayed and the screen returns to the basic screen for copying.
 - 6 Place the originals in the document processor or on the platen and press the **Start** key.
 - 7 Place the next original and press the **Start** key. Repeat these steps to scan the remaining originals.
- After scanning all originals, press [End Scan] (the **Right Select** key) to start copying.

Job Finish Notice

Sends a notice by E-mail when a copy job is complete. User can be notified of the completion of a copy job while working at a remote desk, saving the time spent waiting beside the machine for copying to finish.

NOTE: PC should be configured in advance so that E-mail can be used.

Example of Job Finish Notice

To:	h_pttr@owl-net.net
Subject:	1234 Job end report mail
Job No.:	000002
Result:	OK
End Time:	Wed 27 Apr 2005 14:56:08
File Name:	doc27042005145608
Job Type:	Copy

1234	
[00:c0:ee:d0:01:14]	

Use the procedure below to enable job finish notification when making copies.

- 1 Press the **Copy** key.
- 2 Place the originals on the platen.
- 3 Press the **Function Menu** key. Function Menu appears.

Function Menu:	OK
01 Paper Selection	✓
02 Collate	<input type="checkbox"/>
03 Duplex	<input type="checkbox"/>
[Exit]	

- 4 Press the Δ or ∇ key to select [JobFinish Notice].

```

JobFinish Notice:  ⏏ OK
01 *Off
02 On

```

```

Destination:      ⏏ OK
01 *Address Book
02 Address Entry

```

```

Address Book:     ⏏ OK
☑ Fiala
☑ Maury
☑ Morgan
[ Menu ]

```

```

Address Entry:   ⏏ OK
*****@abcdefg.jp
ABC
[ Text ]

```

5 Press the **OK** key. JobFinish Notice appears.

6 Press the Δ or ∇ key to select [On] and then press the **OK** key.

7 Press the Δ or ∇ key to select [Address Book] or [Address Entry], and then press the **OK** key.

8 If you select [Address Book], select [Address Book] on the next screen and press the **OK** key, and then select the notice destination.

Press [Menu] (the **Right Select** key), select [Detail] on the next screen and press the **OK** key to view the details of the selected notice destination.

If you select [Address Entry], enter the address of the notice destination.

NOTE: Refer to *Character Entry Method on Appendix-5* for details on entering characters.

9 Press the **OK** key.

Completed. is displayed and the screen returns to the basic screen for copying.

10 Press the **Start** key to start copying. Upon completion of the job, an E-mail notice is sent to the selected destination.

File Name Entry

Names a copy job. Add other information such as date and time or job number as necessary. You can check a job history or job status using the job name, date and time, or job number specified here.

Use the procedure below to assign a name to your copy job.

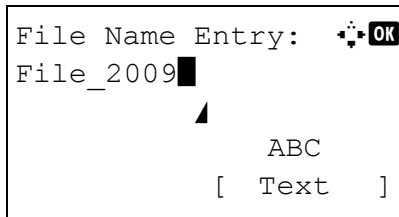
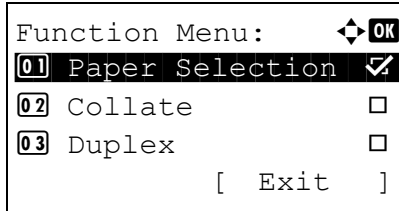

- 1 Press the **Copy** key.
- 2 Place the originals on the platen.
- 3 Press the **Function Menu** key. Function Menu appears.
- 4 Press the Δ or ∇ key to select [File Name Entry].
- 5 Press the **OK** key. File Name Entry appears.
- 6 Enter the file name, press the **OK** key. Additional Info. appears.
- 7 Enter the date, job number, etc. on the screen, and then press the **OK** key.

NOTE: Refer to *Character Entry Method on Appendix-5* for details on entering characters.

NOTE: Refer to *Character Entry Method on Appendix-5* for details on entering characters.

Completed. is displayed and the screen returns to the basic screen for copying.

- 8 Press the **Start** key to start copying.

Print Override

This function allows you to suspend the current print job when you need to make copies immediately. When the interrupt copy job is completed, the machine resumes the suspended print job.

NOTE: If the machine is left for 60 seconds in the interruption copy mode, the interrupt copy job is automatically canceled and the print job resumed.

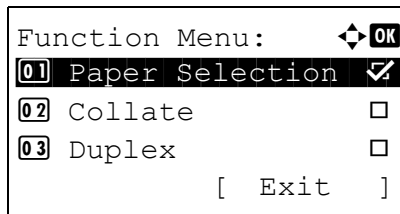

- 1 Press the **Function Menu** key. Function Menu appears.

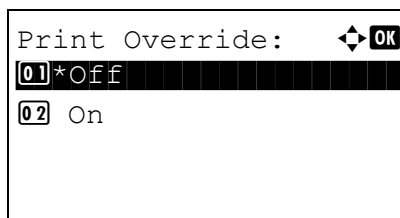

- 2 Press the Δ or ∇ key to select [Print Override].
- 3 Press the **OK** key. Print Override appears.
- 4 Press the Δ or ∇ key to select [On].
- 5 Press the **OK** key. *Completed.* is displayed, the machine is put into the interruption copy mode, and the basic screen appears.
- 6 Perform the interrupt copy job in the same fashion as a normal copy job. When the interrupt copy job is completed, the machine resumes the suspended print job.

5 Sending Functions

This chapter explains the functions available for sending originals.

- Original Size..... 5-2
- Sending Size..... 5-4
- Zoom..... 5-6
- Duplex Sending..... 5-7
- Original Orientation 5-8
- File Format..... 5-10
- Original Image..... 5-12
- Adjusting Density 5-13
- Scan Resolution..... 5-14
- Color / Grayscale / Black and White Selection 5-15
- Continuous Scan..... 5-16
- File Name Entry 5-17
- Subject and Body Entry 5-18
- WSD Scan 5-19
- Job Finish Notice 5-21
- FTP Encrypted TX 5-23

Original Size

Select the size of originals that will serve as the basis for scanning. Be sure to select the original size before starting the sending process.

Choose the original size from the following groups of original size.

Item	Detail	Size
Standard Sizes	Select from standard sizes.	Letter, Legal, Statement, Executive, Officio II, A4, A5, A6, B5, B6, Folio, 16K
Others	Select from Hagaki and Custom Original Size *.	ISO B5, Envelope #10, Envelope #9, Envelope #6, Envelope Monarch, Envelope DL, Envelope C5, Hagaki, Oufuku Hagaki, Youkei 4, Youkei 2 and Custom

* Regarding the setting method of Custom Original Size, refer to *Custom Original Size Setup on page 8-8*.

Use the procedure below to select the original size when sending scanned images.

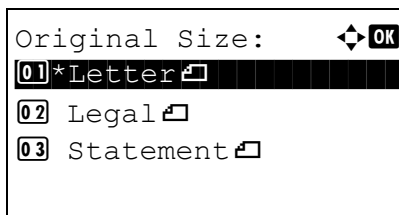

- 1 Press the **Send** key.
- 2 Place the originals on the platen.
- 3 Press the **Function Menu** key. Function Menu appears.
- 4 Press the Δ or ∇ key to select [Original Size].
- 5 Press the **OK** key. Original Size appears.
- 6 Press the Δ or ∇ key to select the desired original size and then press the **OK** key.

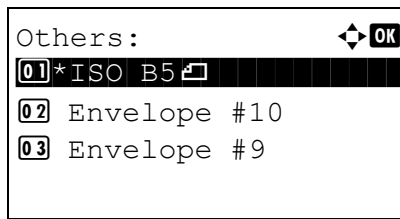

If you select [Others], select one of the other options and then press the **OK** key.

Completed. is displayed and the screen returns to the basic screen for sending.

- 7 Specify the destination, and press the **Start** key to start sending.

Sending Size

Select the sending size (the size of image to be sent).

The table below lists the sizes.

Item	Detail	Size
Standard Sizes	Select from Same as Original Size or Standard Size.	Same as OrigSize, Legal, Letter, Statement, Executive, Offcio II, A4, A5, A6, B5, B6, Folio and 16K
Others	Select from envelope, postcard or the custom sized originals*.	ISO B5, Envelope #10, Envelope #9, Envelope #6, Envelope Monarch, Envelope DL, Envelope C5, Hagaki, Oufuku Hagaki, Youkei 4 and Youkei 2

* For instructions on how to specify the custom original size, refer to *Custom Original Size Setup on page 8-8*.

Relationship between Original Size, Sending Size, and Zoom

Original Size (page 5-2), Sending Size, and Zoom (page 5-6) are related to each other. Refer to the following table.

Original Size and the size you wish to send as are	the same	different
Original Size	Specify as necessary	Specify as necessary
Sending Size	Select [Same as OrigSize]	Select the required size
Zoom	Select [100%] (or [Auto])	Select [Auto]

NOTE: When you select Sending Size that is different from Original Size, and select the Zoom [100%], you can send the image as the actual size (No Zoom).

Use the procedure below to select the size for transmission when sending scanned images.

- 1 Press the **Send** key.
- 2 Place the originals on the platen.
- 3 Press the **Function Menu** key. Function Menu appears.



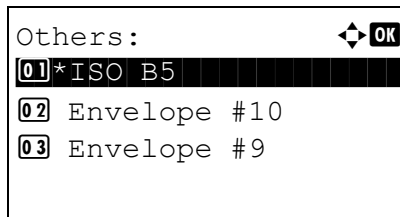
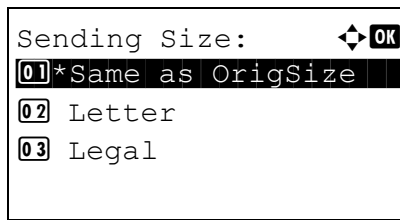

- 4 Press the Δ or ∇ key to select [Sending Size].
- 5 Press the **OK** key. Sending Size appears.

- 6 Press the Δ or ∇ key to select the desired sending size.

If you select [Others], select one of the other options.

5

- 7 Press the **OK** key.

Completed. is displayed and the screen returns to the basic screen for sending.

- 8 Specify the destination, and press the **Start** key to start sending.

Zoom

Scans the original by automatically zooming it depending on the sending size.

The table below lists the available options.

Item	Detail
100%	No Zoom (to be scanned at actual size)
Auto	Zoomed automatically according to the specified sending size.

NOTE: When zooming in or out, see *Sending Size on page 5-4* when selecting the sending size.

When Custom Size or *Size Entry* is selected as the original size, the originals are sent at normal size and zooming cannot be used.

Depending on the combination of original size and sending size, the image is placed at the edge of the paper.

Use the procedure below to enlarge or reduce the original to match the transmission size.

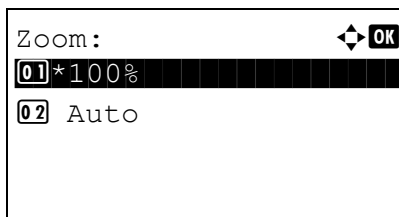

- 1 Press the **Send** key.
- 2 Place the originals on the platen.
- 3 Select the transmission size.
- 4 Press the **Function Menu** key. Function Menu appears.
- 5 Press the Δ or ∇ key to select [Zoom].
- 6 Press the **OK** key. Zoom appears.
- 7 Press the Δ or ∇ key to select [100%] or [Auto] and then press the **OK** key.

Completed. is displayed and the screen returns to the basic screen for sending.
- 8 Specify the destination, and press the **Start** key to start sending.

Duplex Sending

Select the type and binding of original depending on the original.

The table below lists the binding directions for each original type.

Original	Type	Binding	Binding
1-sided Sheet Original	1-sided	—	—
2-sided Sheet Original	2-sided*	Binding Left/Right, Binding Top	Top Edge Top, Top Edge Left

* Only when the optional document processor is installed for FS-1028MFP.

Use the procedure below to select the original type and binding direction when sending scanned originals.

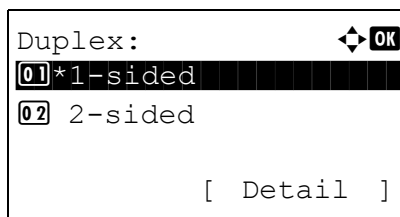

- 1 Press the **Send** key.
- 2 Place the originals on the platen.
- 3 Press the **Function Menu** key. Function Menu appears.

- 4 Press the Δ or ∇ key to select [Duplex].
- 5 Press the **OK** key. Duplex appears.

- 6 Press the Δ or ∇ key to select [1-sided] or [2-sided].

If you select [2-sided], press [Detail] (the **Right Select** key), select the binding edge and press the **OK** key, and then select the original setting orientation on the next screen.

- 7 Press the **OK** key.

Completed. is displayed and the screen returns to the basic screen for sending.

- 8 Specify the destination, and press the **Start** key to start sending.

Original Orientation

To send the document in the orientation that can be read properly, specify the upper orientation of original. To use the functions below, select the orientation in which the original is set on the platen.

- 1-sided / 2-sided Selection

When placing the original on the platen

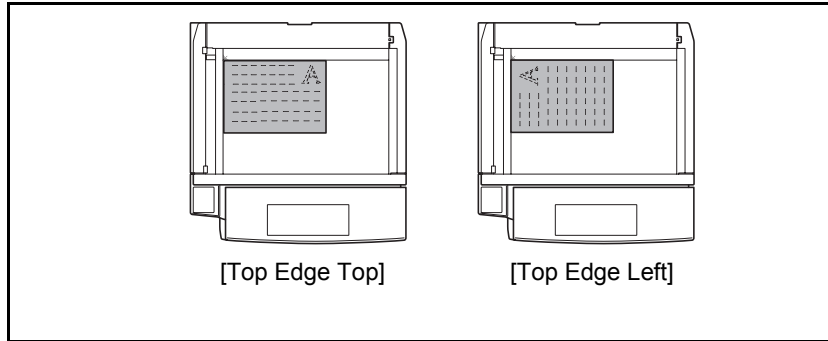

When placing the original on the optional document processor

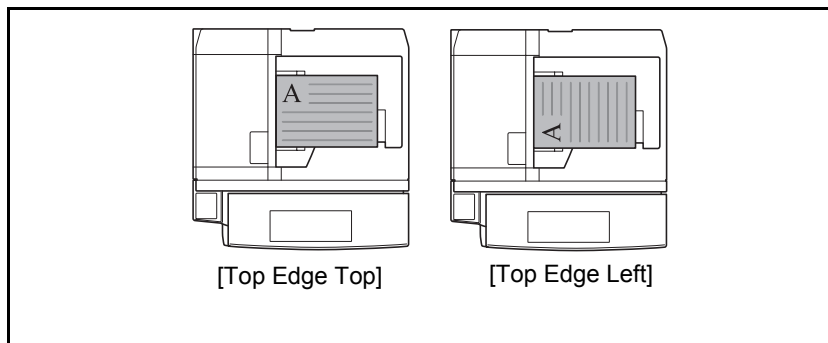

Use the procedure below to select the orientation when placing the originals on the platen for sending.

- 1 Press the **Send** key.
- 2 Place the originals on the platen.
- 3 Press the **Function Menu** key. Function Menu appears.



- 4 Press the Δ or ∇ key to select [Orig.Orientation].

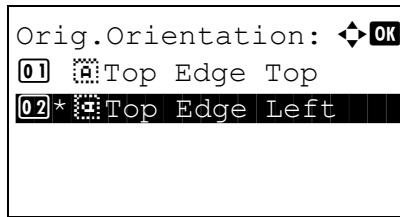

5 Press the **OK** key. Orig.Orientation appears.

6 Press the Δ or ∇ key to select [Top Edge Top] or [Top Edge Left].

7 Press the **OK** key.

Completed. is displayed and the screen returns to the basic screen for sending.

8 Specify the destination, and press the **Start** key to start sending.

5

File Format

Select the file format of the image to send.

The table below lists the file formats and their details.

File Format	Adjustable range of image quality	Color mode
PDF	1 Low Quality (High Comp.) to 5 High Quality (Low Comp.)	Full Color, Grayscale, Black and White
TIFF	1 Low Quality (High Comp.) to 5 High Quality (Low Comp.)	Full Color, Grayscale, Black and White
XPS	1 Low Quality (High Comp.) to 5 High Quality (Low Comp.)	Full Color, Grayscale
JPEG	1 Low Quality (High Comp.) to 5 High Quality (Low Comp.)	Full Color, Grayscale

NOTE: You cannot select [JPEG] if [Black and White] is selected for the color mode.

Use the procedure below to select the file format for transmission.

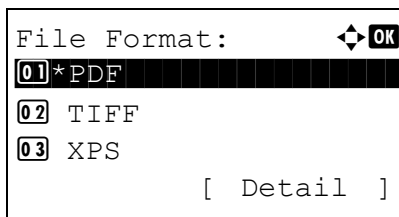

- 1 Press the **Send** key.
- 2 Place the originals on the platen.
- 3 Press the **Function Menu** key. Function Menu appears.
- 4 Press the Δ or ∇ key to select [File Format].
- 5 Press the **OK** key. File Format appears.
- 6 Press the Δ or ∇ key to select the file format from [PDF], [TIFF], [XPS] or [JPEG].

If Full Color or Grayscale has been selected for the color mode for scanning, press [Detail] (the **Right Select** key) and select the image quality.

7 Press the **OK** key.

Completed. is displayed and the screen returns to the basic screen for sending.

8 Specify the destination, and press the **Start** key to start sending.

Original Image

Select image quality suitable to the type of original.

The table below shows the quality options.

Item	Detail
Text+Photo	Text and photos together.
Photo	For photos taken with a camera.
Text	Only text, no photos.

Use the procedure below to select the quality when sending scanned originals.

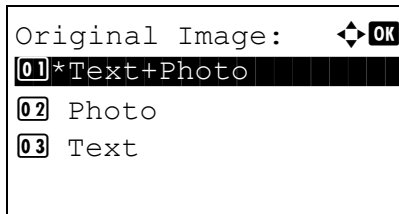

- 1 Press the **Send** key.
- 2 Place the originals on the platen.
- 3 Press the **Function Menu** key. Function Menu appears.
- 4 Press the Δ or ∇ key to select [Original Image].
- 5 Press the **OK** key. Original Image appears.
- 6 Press the Δ or ∇ key to select the desired image quality.
- 7 Press the **OK** key.
Completed. is displayed and the screen returns to the basic screen for sending.
- 8 Specify the destination, and press the **Start** key to start sending.

Adjusting Density

Use the procedure below to adjust the density when scanning the originals.

The table below shows the available settings.

Item	Detail
Manual	Adjust density using 7 levels.
Auto	Optimum density is selected according to the density of the original.

The procedure for adjusting the density is explained below.

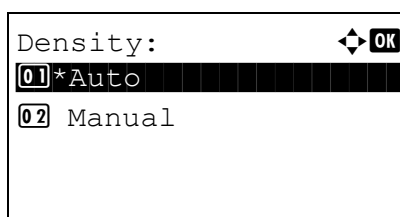

- 1 Press the **Send** key.
- 2 Place the originals on the platen.
- 3 Press the **Function Menu** key. Function Menu appears.
- 4 Press the Δ or ∇ key to select [Density].
- 5 Press the **OK** key. Density appears.
- 6 Press the Δ or ∇ key to select [Auto] or [Manual].
If you select [Manual], press the **OK** key, and then select the density on the next screen.
- 7 Press the **OK** key.
Completed. is displayed and the screen returns to the basic screen for sending.
- 8 Specify the destination, and press the **Start** key to start sending.

Scan Resolution

Select the fineness of scanning resolution. The finer the scanning becomes (the larger the number becomes), the better the image quality becomes. However, better resolution also results in larger file size (file capacity) and longer scanning and sending times. The selectable resolution is 200x100dpi Normal, 200x200dpi Fine, 200x400dpi Super Fine, 300x300dpi, 400x400dpi Ultra Fine, or 600x600dpi.

The procedure for adjusting the scanning resolution when sending a scanned image is explained below.

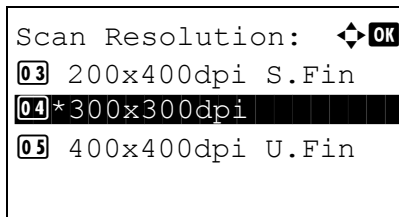
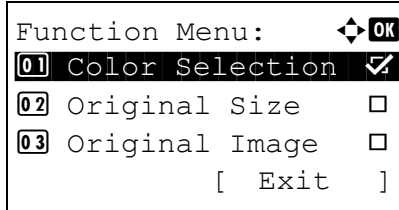

- 1 Press the **Send** key.
- 2 Place the originals on the platen.
- 3 Press the **Function Menu** key. Function Menu appears.
- 4 Press the Δ or ∇ key to select [Scan Resolution].
- 5 Press the **OK** key. Scan Resolution appears.
- 6 Press the Δ or ∇ key to select the desired scan resolution.
- 7 Press the **OK** key.
Completed. is displayed and the screen returns to the basic screen for sending.
- 8 Specify the destination, and press the **Start** key to start sending.

Color / Grayscale / Black and White Selection

This feature allows you to select the color mode used for scanning when sending images. You can select from Full Color, Grayscale or Black & White.

Use the procedure below to select the color mode when sending scanned images.

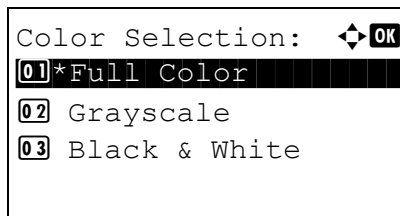

- 1 Press the **Send** key.
- 2 Place the originals on the platen.
- 3 Press the **Function Menu** key. Function Menu appears.
- 4 Press the Δ or ∇ key to select [Color Selection].
- 5 Press the **OK** key. Color Selection appears.
- 6 Press the Δ or ∇ key to select the desired color mode.
- 7 Press the **OK** key.
Completed. is displayed and the screen returns to the basic screen for sending.
- 8 Specify the destination, and press the **Start** key to start sending.

Continuous Scan

When the multi-page originals cannot be placed in the document processor at one time, the originals can be scanned in separate batches and then sent as one job. With this function, originals can be scanned one after another until you press [End Scan] (the **Right Select** key).

The procedure for using continuous scanning when sending scanned images is explained below.

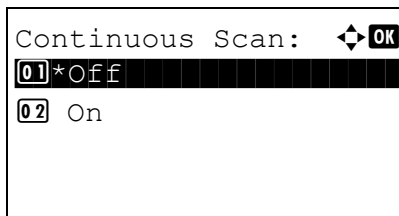

- 1 Press the **Send** key.
- 2 Press the **Function Menu** key. Function Menu appears.
- 3 Press the Δ or ∇ key to select [Continuous Scan].
- 4 Press the **OK** key. Continuous Scan appears.
- 5 Press the Δ or ∇ key to select [On] and then press the **OK** key.

Completed. is displayed and the screen returns to the basic screen for sending.
- 6 Specify the destination.
- 7 Place the original, and press the **Start** key.
- 8 Place the next original, and press the **Start** key. Scan the remaining originals by the same procedure.

When you have scanned all the originals, press [End Scan] (the **Right Select** key) to start sending.

File Name Entry

This setting allows you to assign a document name to scanned images. You can specify a default for the document name.

Use the procedure below to assign names to scanned documents that you are sending.

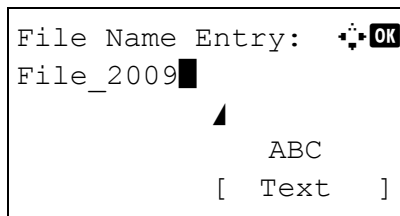

- 1 Press the **Send** key.
- 2 Place the originals on the platen.
- 3 Press the **Function Menu** key. Function Menu appears.
- 4 Press the Δ or ∇ key to select [File Name Entry].
- 5 Press the **OK** key. File Name Entry appears.

NOTE: Refer to *Character Entry Method on Appendix-5* for details on entering characters.

- 6 Enter the file name, press the **OK** key. Additional Info. appears.

NOTE: Refer to *Character Entry Method on Appendix-5* for details on entering characters.

- 7 Enter the date, job number, etc. on the screen, and then press the **OK** key.

NOTE: Refer to *Character Entry Method on Appendix-5* for details on entering characters.

Completed. is displayed and the screen returns to the basic screen for sending.

- 8 Specify the destination, and press the **Start** key to start sending.

Subject and Body Entry

When sending E-mail, enter the subject and body of the E-mail.

Use the procedure below to enter the subject and body for an E-mail message and then send the E-mail.

NOTE: Refer to *Character Entry Method on Appendix-5* for details on entering characters.

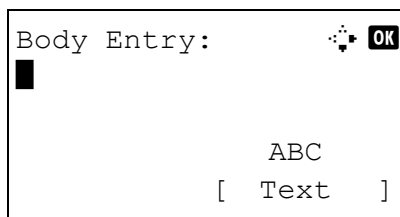
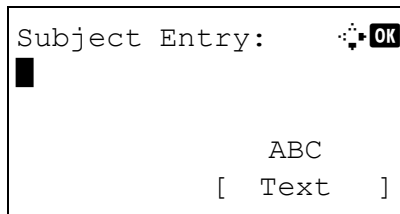

- 1 Press the **Send** key.
- 2 Press the **Function Menu** key. Function Menu appears.
- 3 Press the Δ or ∇ key to select [Subject/Body].
- 4 Press the **OK** key. Subject Entry appears.

- 5 Enter the subject and press the **OK** key.

NOTE: Up to 60 characters can be entered for the subject.

- 6 Enter the body and press the **OK** key.

NOTE: Up to 500 characters can be entered for the body.

Completed. is displayed and the screen returns to the basic screen for sending.

- 7 Specify the destination, and press the **Start** key to start sending.

WSD Scan

WSD Scan saves images of originals scanned on this machine as files on a WSD-compatible computer.

NOTE: For information on operating the computer, refer to the operating system help for your computer. To use WSD Scan, *WSD Scan Setup* (page 8-132) must be set to [On] in the network settings.

Procedure using computer

- 1 Install the WIA driver on your computer in the custom mode from the supplied CD-ROM (Product Library).

NOTE: For details of installation for WIA driver, refer to *Setup Guide*.

- 2 Select **Start** button of the Windows display, and then **Network**.
- 3 Select the machine displayed *Multifunctional Devices*, and then right-click **Install**.
Installing of the driver starts.
- 4 After installing the driver, click **Close**.

Procedure using this machine

- 1 Press the **Send** key.
- 2 Place the originals in the document processor or on the platen.
Displays the screen for sending.

NOTE: Depending on the settings, the address book screen may appear. In this event, press [Cancel] to display the screen for sending.

- 3 Press the Δ or ∇ key to select [WSD Scan].

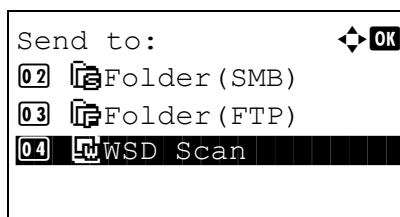

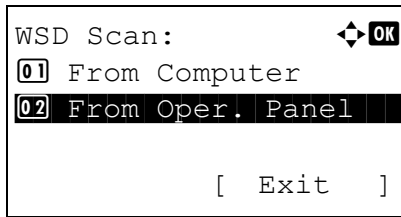

4 Press the **OK** key. WSD Scan appears.

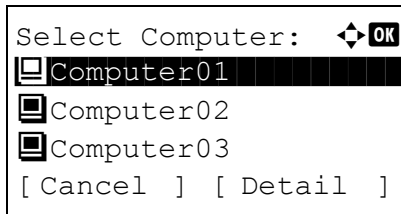

5 Press the Δ or ∇ key to select [From Oper. Panel].

6 Select the destination computer from the computer list.

Press [Detail] (the **Right Select** key) to see the information of the selected computer.

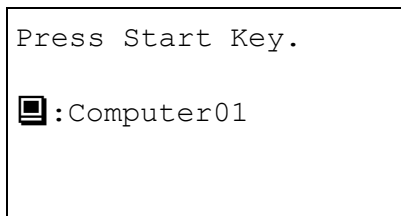

7 Press the **OK** key to confirm the destination, and then press the **Start** key. Transmission starts.

NOTE: To change the destination computer, press the **Back** key and then press [Yes] (the **Left Select** key). This brings you back to step 6.

NOTE: To use WSD Scan from your computer, press [From Computer] in step 5 and then scan the original from the computer.

Job Finish Notice

This feature sends an e-mail providing notification that transmission has been completed.

Use the procedure below to specify the Job Finish Notice settings.

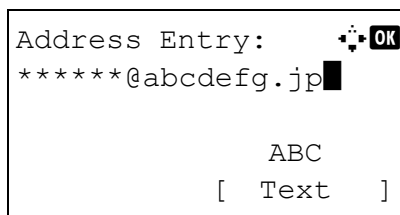
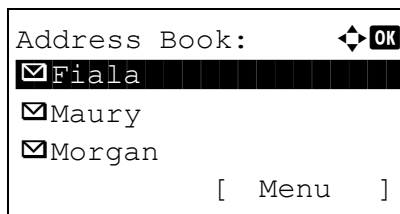
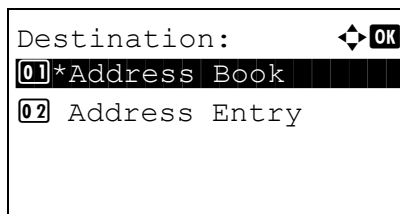
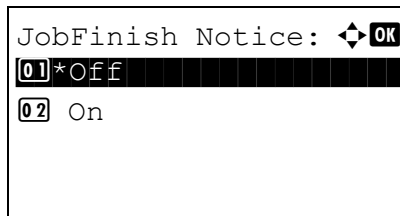

- 1 Press the **Send** key.
- 2 Place the originals on the platen.
- 3 Press the **Function Menu** key. Function Menu appears.
- 4 Press the Δ or ∇ key to select [JobFinish Notice].
- 5 Press the **OK** key. JobFinish Notice appears.
- 6 Press the Δ or ∇ key to select [On] and then press the **OK** key.
- 7 Press the Δ or ∇ key to select [Address Book] or [Address Entry], and then press the **OK** key.
- 8 If you select [Address Book], select [Address Book] on the next screen and press the **OK** key, and then select the notice destination.

Press [Menu] (the **Right Select** key), select [Detail] on the next screen and press the **OK** key to view the details of the selected notice destination.

If you select [Address Entry], enter the address of the notice destination.

NOTE: Refer to *Character Entry Method* on Appendix-5 for details on entering characters.

- 9** Press the **OK** key.

Completed. is displayed and the screen returns to the basic screen for sending.

- 10** Specify the destination, and press the **Start** key to start sending.

When the sending is completed, the finish notice is sent to the specified E-mail address.

FTP Encrypted TX

This allows you to encrypt documents when you send them. If you select [On] in this option, you can then select the encryption method in the basic send screen.

Use the procedure below to scan and send originals as encrypted files.

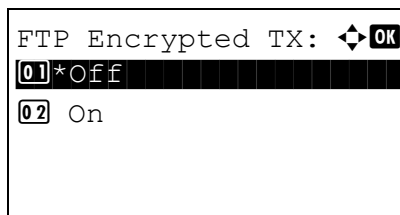

- 1 Press the **Send** key.
- 2 Place the originals in the document processor or on the platen.
- 3 Press the **Function Menu** key. Function Menu appears.
- 4 Press the Δ or ∇ key to select [FTP Encrypted TX].
- 5 Press the **OK** key. FTP Encrypted TX appears.
- 6 Press the Δ or ∇ key to select [On] and then press the **OK** key.

Completed. is displayed and the screen returns to the basic screen for sending.

NOTE: Click *Advanced* -> Secure Protocols in the COMMAND CENTER. Be sure that **SSL** of **Secure Protocol Settings** is *On* and more than two effective encryptions are selected in **Clientside Settings**. For details, refer to the *KYOCERA COMMAND CENTER Operation Guide*.

Sanning Image using Application

Be sure that you connect your PC with the machine using the USB cable and install the Kyocera TWAIN or WIA Driver. The scan can be carried out from any TWAIN or WIA compatible application program. For details of installation for TWAIN or WIA driver, refer to *Setup Guide*.

The following procedure is an example for scan operation using the TWAIN Driver. Operate the WIA Drivers in the same manner.

- 1** Connect your computer to the machine using a USB cable.
- 2** Place the originals in the document processor or on the platen.
- 3** Use the TWAIN-compatible application to scan from your computer.

NOTE: When the login user name and password entry screen appears, enter them and click the OK button.

- 4** Choose the appropriate settings and click Scan. The scanned data will be sent to your computer.

6 Document Box

This chapter explains the typical procedure for utilizing Document Box.

- Printing Documents Stored in USB Memory6-2
- Saving Documents to USB Memory (Scan to USB)6-4
- Removing USB Memory6-6

Printing Documents Stored in USB Memory

Plugging USB memory directly into the machine enables you to quickly and easily print the files stored in the USB memory without having to use a computer.

Limitations

- The following file types can be printed:
 - PDF file (Version 1.5)
 - TIFF file (TIFF V6/TTN2 format)
 - XPS file
- PDF files you wish to print should have an extension (.pdf).
- Files to be printed should be saved no further down than the top 3 folder levels.
- Plug the USB memory directly into the USB memory slot (A1). We do not guarantee that USB memory printing is error free if a USB hub is used.

Printing

Print documents stored in the removable USB memory.

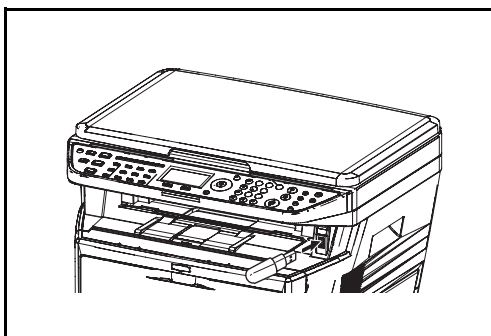

- 1 Plug the USB memory into the USB memory slot.

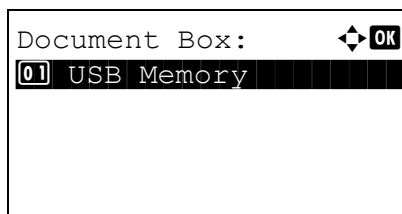

- 2 Press the **Document Box** key. The Document Box menu appears.

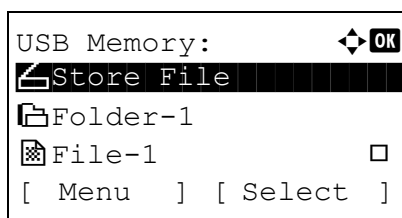

- 3 Press the Δ or ∇ key to select [USB Memory].
- 4 Press the **OK** key. USB Memory appears.

- 5 Press the Δ or ∇ key to select the the file you want to print.

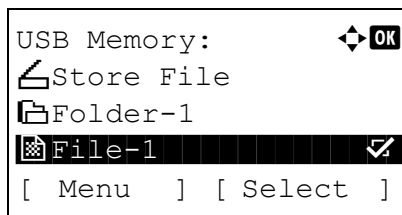

Select a folder and press the **OK** key to view the files in the folder. Documents in the top 3 folder levels including the root directory can be viewed.

- 6** Press [Select] (the **Right Select** key). The selected file name is indicated by a checkmark next to it.

When you want to print additional files, repeat steps 5 to 6 to select them.

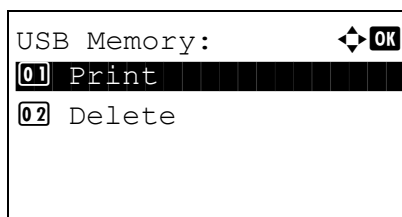

- 7** Press the **OK** key. A menu appears.

- 8** Press the Δ or ∇ key to select [Print].

- 9** Press the **OK** key. The basic screen appears. Change the number of copies, 1-sided/2-sided printing, etc., as necessary. For changing print settings, refer to *Copying on page 3-9* and *Copying Functions on page 4-1*.

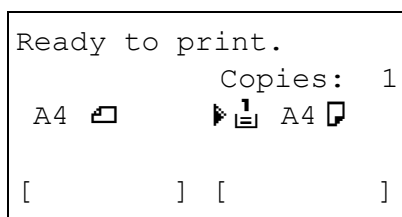

- 10** Press the **Start** key. Printing of the selected file begins.

Saving Documents to USB Memory (Scan to USB)

This function allows you to store scanned image files in USB memory connected to the machine. You can store files in PDF, TIFF, JPEG or XPS format.

NOTE: The maximum number of the storable files is 100.

Storing Documents

The procedure for storing documents in removable USB memory is explained below.

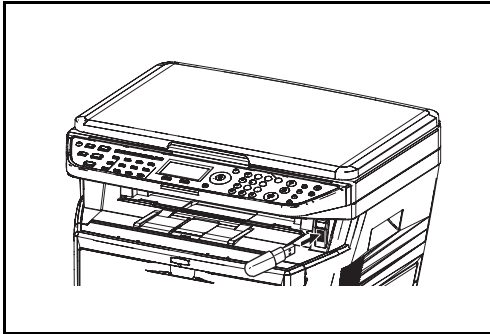

1 Plug the USB memory into the USB memory slot .

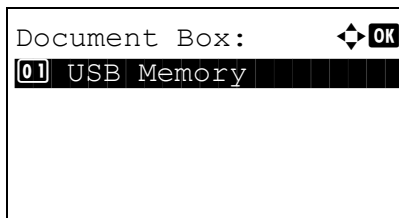

2 Press the **Document Box** key. The Document Box menu appears.

3 Press the Δ or ∇ key to select [USB Memory].

4 Press the **OK** key. USB Memory appears.

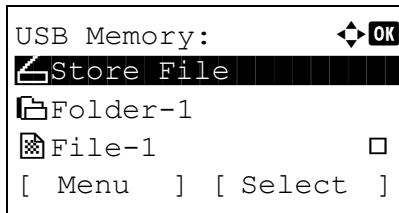

5 Press the Δ or ∇ key to select [Store File].

6 Press the **OK** key. The basic screen appears. Change the original type, file format, etc., as necessary. For changing scan settings, refer to *Sending Functions on page 5-1*.

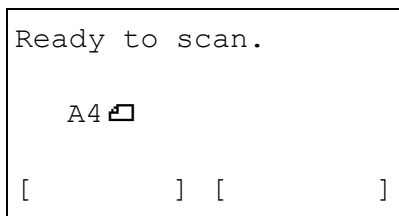

7 Press the **Start** key. The original is scanned and the data is stored in the USB memory.

IMPORTANT: When removing the USB memory, ensure that you use the correct removal procedure, as described in *Removing USB Memory on page 6-6*.

Removing USB Memory

Remove the USB memory.

IMPORTANT: Be sure to follow the proper procedure to avoid damaging the data or USB memory.

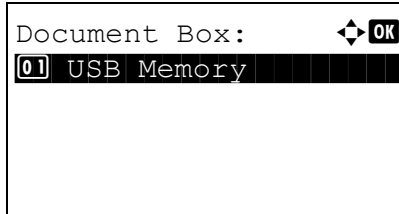

1 Press the **Document Box** key. The Document Box menu appears.

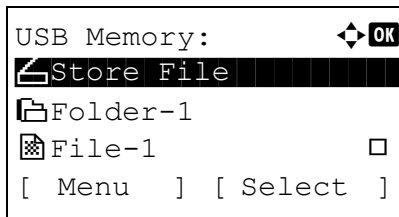

2 Press the Δ or ∇ key to select [USB Memory].

3 Press the **OK** key. USB Memory appears.

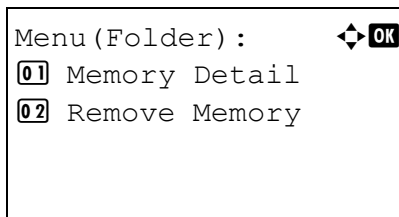

4 Press [Menu] (the **Left Select** key). A menu appears.

NOTE: This is the image on the screen when a folder is selected. [Open] is not displayed when a file is selected.

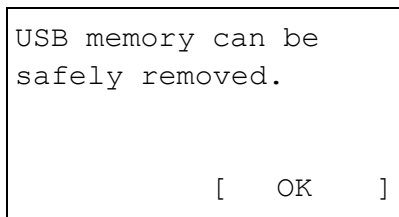

5 Press the Δ or ∇ key to select [Remove Memory].

6 Press the **OK** key. A confirmation message appears.

7 Press [OK] (the **Right Select** key) or remove the USB memory. The screen returns to the Document Box menu.

7 Status / Job Cancel

This chapter explains how to check the status and history of jobs and cancel the jobs being processed or waiting to be printed.

This chapter also explains how to check the remaining amount of toner and paper and the status of devices, and how to cancel the fax communication.

- Checking Job Status 7-2
- Checking Job History 7-8
- Sending the Job Log History 7-13
- Pause and Resumption of Jobs 7-19
- Canceling of Jobs 7-19
- Device/Communication 7-20

Checking Job Status

Check the status of jobs being processed or waiting to be printed.

Available Status Screens

The processing and waiting statuses of jobs are displayed as a list on the Message Display in four different screens - Print Job, Send Job, Store Job and Scheduled Job. The following job statuses are available.

Screen	Job statuses to be displayed
Print Job	<ul style="list-style-type: none"> • Copy • Printer • FAX reception • Document Box • E-mail reception • Job Report /List • Printing data from removable memory
Send Job	<ul style="list-style-type: none"> • FAX transmission • PC (SMB/FTP) transmission • E-mail • Application • Multiple destination • Sending Job FAX using Delayed transmission
Store Job	<ul style="list-style-type: none"> • Scan • FAX
Scheduled Job	<ul style="list-style-type: none"> • FAX

Print Job Status Screen

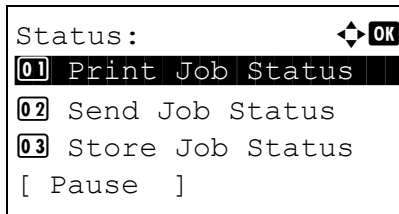

1 Press the **Status/Job Cancel** key. The Status menu appears.

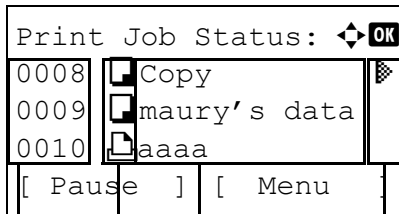

2 Press the Δ or ∇ key to select [Print Job Status].

3 Press the **OK** key. Print Job Status appears. Press the Δ or ∇ key to check the print queue.

1 2 3 4

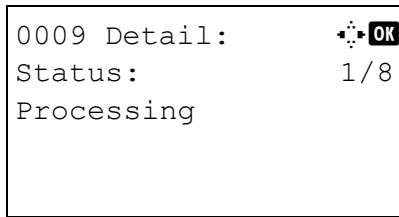

Press the **OK** key to check detailed information of the selected job.

NOTE: You can also check the job information by pressing [Menu] (the **Right Select** key) and selecting [Detail] in the menu that appears.







Press the < or > key to switch the display to other information items. The items displayed are as follows:

- Status (status of job)
- Accepted Time
- Job Name
- Job Type
- User Name
- Page and Copy
(number of pages and copies to be printed)
- Original Page (number of pages of the original)

When complete job name not displayed in detailed information

When the job name in Job Name is displayed in a short form, press [Detail] (the **Right Select** key) to see the complete job name. Press the **OK** key to return to the original screen.

The table below lists the items displayed in the Printing Jobs Status screen.

No.	Item / Key	Detail
1	Job No.	Acceptance No. of job
2	Type	Icons that indicate the job type ■ Copy job  ■ Printer job  ■ FAX reception  ■ E-mail reception  ■ Job from Document Box  ■ Report / List  ■ Data from Removable Memory 
3	Job Name	Job Name or file name

No.	Item / Key	Detail
4	Status	Status of job 🖨️: Printing ⏸️: Print Waiting no icon: Pausing print job or error 🖨️: Preferential print job is running ⏸️: Suspended because preferential print job is running

Send Job Status screen

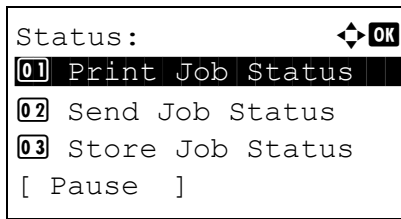

1 Press the **Status/Job Cancel** key. The Status menu appears.

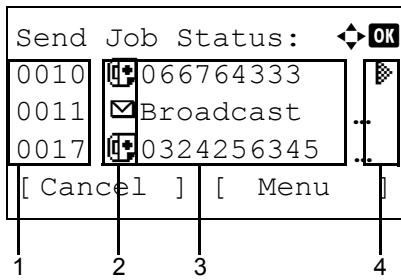

2 Press the Δ or ∇ key to select [Send Job Status].

3 Press the **OK** key. Send Job Status appears. Press the Δ or ∇ key to check the send queue.

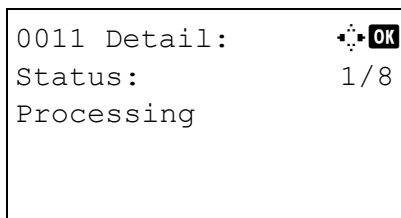

Press the **OK** key to check detailed information of the selected job.

NOTE: You can also check the job information by pressing [Menu] (the **Right Select** key) and selecting [Detail] in the menu that appears.

Press the \triangleleft or \triangleright key to switch the display to other information items. The items displayed are as follows:

- Status (status of job)
- Accepted Time
- Job Name
- Job Type
- User Name
- Original Pages (number of pages of the original)
- Color/B & W (color mode of the original)
- Destination

When complete job name not displayed in detailed information

Press [Detail] (the **Right Select** key) in Job Name to see the complete job name. Press the **OK** key to return to the original screen.







When complete destination name not displayed in detailed information

When there is only one destination, press [Detail] (the **Right Select** key) in Destination to see the complete destination name. Press the **OK** key to return to the original screen.

When there are two or more destinations, press [List] (the **Right Select** key) in Destination to display the destination list. Press the Δ or ∇ key to select the desired destination and press the **OK** key. This displays the complete name of the destination. Press the **OK** key to return to the destination list.

Pressing [Exit] (the **Right Select** key) while the destination list is displayed brings you back to the original screen.

The table below lists the items displayed in the Sending Jobs Status screen.

No.	Item / Key	Detail
1	Job No.	Acceptance No. of job
2	Type	Icons that indicate the job type ■ Sending Job FAX  ■ Sending Job PC (SMB)  ■ Sending Job PC (FTP)  ■ Sending Job E-mail  ■ Sending Job TWAIN2  ■ Sending Job WSD Scan  When broadcast sending is done, <i>Broadcast</i> is displayed next to the icon.
3	Destination	Destination (Either destination name, FAX number, E-mail address, or server name)
4	Status	Status of job  : Sending no icon: Sending Waiting II: Pausing the job X: Stop sending

Store Job Status screen

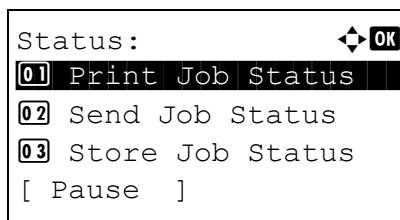

1 Press the **Status/Job Cancel** key. The Status menu appears.

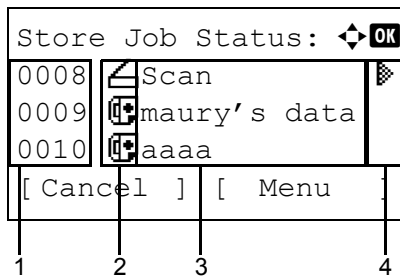

2 Press the Δ or ∇ key to select [Store Job Status].

3 Press the **OK** key. Store Job Status appears. Press the Δ or ∇ key to check the store queue.

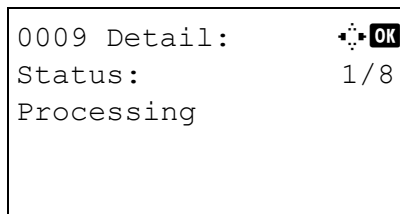

Press the **OK** key to check detailed information of the selected job.

NOTE: You can also check the job information by pressing [Menu] (the **Right Select** key) and selecting [Detail] in the menu that appears.

Press the \triangleleft or \triangleright key to switch the display to other information items. The items displayed are as follows:

- Status (status of job)
- Accepted Time
- Job Name
- Job Type
- User Name
- Original Pages (number of pages of the original)
- Color/B & W (color mode of the original)
- Sender Info. (destination information)



When complete job name not displayed in detailed information

Press [Detail] (the **Right Select** key) in Job Name to see the complete job name. Press the **OK** key to return to the original screen.

When complete destination information not displayed in detailed information

Press [Detail] (the **Right Select** key) in Sender Info. to see the complete destination information. Press the **OK** key to return to the original screen.

The table below lists the items displayed in the Storing Jobs Status screen.

No.	Display / Key	Details
1	Job No.	Acceptance No. of job
2	Type	Icons that indicate the job type ■ Storing Job Scan  ■ Storing Job FAX 
3	Job Name	Job name or file name is displayed.
4	Status	Status of job ▶ : Storing Data no icon: Storing Waiting

Checking Job History

Check the history of completed jobs.

NOTE: Job history is also available by COMMAND CENTER or KM-NET VIEWER from the computer.

Available Job History Screens

The job histories are displayed separately in three screens - Print Job, Send Job, Store Job and Scheduled Job. The following job histories are available.

Screen	Job histories to be displayed
Print Job	<ul style="list-style-type: none"> • Copy • Printer • FAX reception • E-mail reception • Job Report / List • Printing data from removable memory
Send Job	<ul style="list-style-type: none"> • FAX • PC (SMB/FTP) • E-mail • Application • Multiple destination
Store Job	<ul style="list-style-type: none"> • Scan • FAX
Scheduled Job	<ul style="list-style-type: none"> • FAX

Displaying Print Job Log

```
Status: ⏏ OK
01 Print Job Status
02 Send Job Status
03 Store Job Status
[ Pause ]
```

1 Press the **Status/Job Cancel** key. The Status menu appears.

```
Print Job Log: ⏏ OK
0006  maury's da. ⚠
0007  tom's da. OK
0008  susan's da. OK
[ Detail ]
```

2 Press the Δ or ∇ key to select [Print Job Log].

3 Press the **OK** key. Print Job Log appears. Press the Δ or ∇ key to check the print log.

A job result icon is displayed on the extreme right of each job.

OK : Job completed normally

⚠ : Job error

⊘ : Job aborted

NOTE: For details of other items, refer to *Print Job Status Screen on page 7-2*.

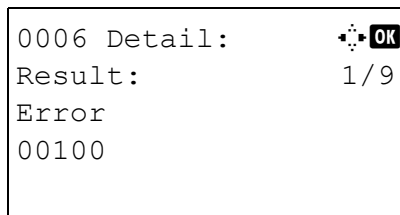

Press the **OK** key or [Detail] (the **Right Select** key) to check the detailed information of the selected print log.

Press the < or > key to switch the display to other information items. The items displayed are as follows:

Result
 Accepted Time
 End Time
 Job Name
 Job Type
 User Name
 Page and Copy
 (number of pages and copies to be printed)
 Original Page (number of pages of the original)
 Sender Info. (destination information)

7

When complete job name not displayed in detailed information

When the job name in Job Name is displayed in a short form, press [Detail] (the **Right Select** key) to see the complete job name. Press the **OK** key to return to the original screen.

When complete destination information not displayed in detailed information

Press [Detail] (the **Right Select** key) in Sender Info. to see the complete destination information. Press the **OK** key to return to the original screen.

Displaying Send Job Log

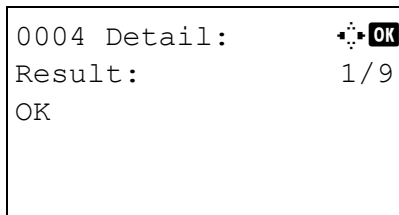
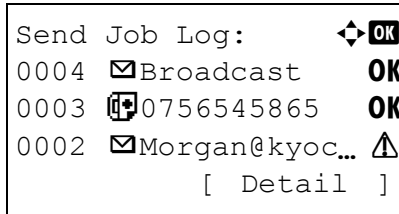
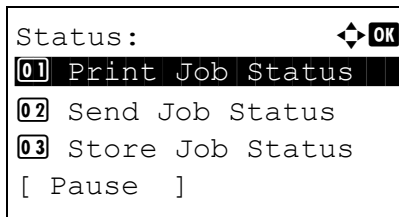

1 Press the **Status/Job Cancel** key. The Status menu appears.

2 Press the Δ or ∇ key to select [Send Job Log].

3 Press the **OK** key. Send Job Log appears. Press the Δ or ∇ key to check the send log.

A job result icon is displayed on the extreme right of each job.

OK : Job completed normally

Δ : Job error

∇ : Job aborted

NOTE: For details of other items, refer to *Send Job Status* screen on page 7-4.

Press the **OK** key or [Detail] (the **Right Select** key) to check the detailed information of the selected send log.

Press the \triangleleft or \triangleright key to switch the display to other information items. The items displayed are as follows:

- Result
- Accepted Time
- End Time
- Job Name
- Job Type
- User Name
- Original Pages (number of pages of the original)
- Color/B & W (color mode of the original)
- Destination

When complete job name not displayed in detailed information

Press [Detail] (the **Right Select** key) in Job Name to see the complete job name. Press the **OK** key to return to the original screen.

When complete destination name not displayed in detailed information



When there is only one destination, press [Detail] (the **Right Select** key) in Destination to see the complete destination name. Press the **OK** key to return to the original screen.

When there are two or more destinations, press [List] (the **Right Select** key) in Destination to display the destination list. Press the Δ or ∇ key to select the desired destination and press the **OK** key. This displays the complete name of the destination. Press the **OK** key to return to the destination list.

Pressing [Exit] (the **Right Select** key) while the destination list is displayed brings you back to the original screen.

Displaying Store Job Log

```
Status: ⏏ OK
01 Print Job Status
02 Send Job Status
03 Store Job Status
[ Pause ]
```

```
Store Job Log: ⏏ OK
0008  Scan OK
0009  maury's data ⚠
0010  aaaaa ⚠
[ Detail ]
```

1 Press the **Status/Job Cancel** key. The Status menu appears.

2 Press the Δ or ∇ key to select [Store Job Log].

3 Press the **OK** key. Store Job Log appears. Press the Δ or ∇ key to check the store queue.

A job result icon is displayed on the extreme right of each job.

OK : Job completed normally

Δ : Job error

 : Job aborted

NOTE: For details of other items, refer to *Store Job Status* screen on page 7-6.

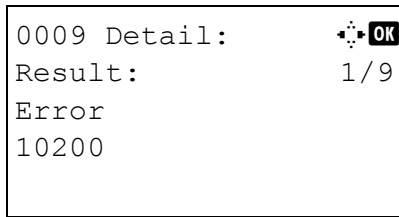

Press the **OK** key or [Detail] (the **Right Select** key) to check the detailed information of the selected job.

Press the < or > key to switch the display to other information items. The items displayed are as follows:

- Result
- Accepted Time
- End Time
- Job Name
- Job Type
- User Name
- Original Pages (number of pages of the original)
- Color/B & W (color mode of the original)
- Sender Info. (destination information)

When complete job name not displayed in detailed information

Press [Detail] (the **Right Select** key) in Job Name to see the complete job name. Press the **OK** key to return to the original screen.

When complete destination information not displayed in detailed information

Press [Detail] (the **Right Select** key) in Sender Info. to see the complete destination information. Press the **OK** key to return to the original screen.

Sending the Job Log History

You can send the job log history by e-mail. You can either send it manually as needed or have it sent automatically whenever a set number of jobs is reached.

Displaying Job Log History Menu

```
Sys. Menu/Count.:  OK
01 Report
02 Counter
03 System
[ Exit ]
```

```
Login User Name:  OK
[REDACTED]
Login Password:
[ Menu ] [ Login ]
```

```
Sys. Menu/Count.:  OK
01 Report
02 Counter
03 System
[ Exit ]
```

```
Report:  OK
01 Report Print
02 Result Rpt Set.
03 Job Log History
[ Exit ]
```

```
Copy, print, send,
storing functions
are restricted now.
23:00 - 08:30
```

- 1 Press the **System Menu/Counter** key on the main unit operation panel. The Sys. Menu/Count. menu appears.

When you are performing user management and have not logged in, a login screen will appear. Then, enter the user ID and password to log in.

NOTE:

- Refer to *Character Entry Method* on Appendix-5 for details on entering characters.
- If [Netwk Authentic.] is selected as the user authentication method, press [Menu] (the **Left Select** key) to select the authentication destination.

- 2 In the Sys. Menu/Count. menu, press the Δ or ∇ key to select [Report].

- 3 Press the **OK** key. The Report menu appears.

IMPORTANT: When a time period to prohibit acceptance of jobs is set in timer settings, the screen will display *Copy, print, send, storing functions are restricted now.* and return to the standby screen.

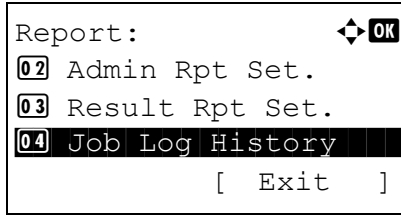

4 Press the Δ or ∇ key to select [Job Log History].

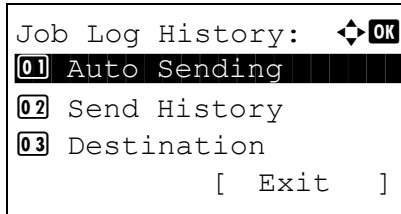

5 Press the **OK** key. The Job Log History menu appears.

Setting the destination

Set the destination to which job log histories are sent.

Use the procedure below to set the destination.

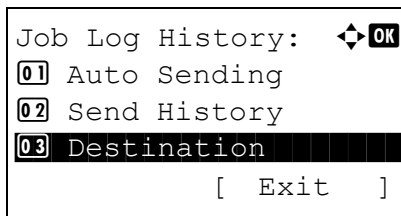

1 In the Job Log History menu, press the Δ or ∇ key to select [Destination].

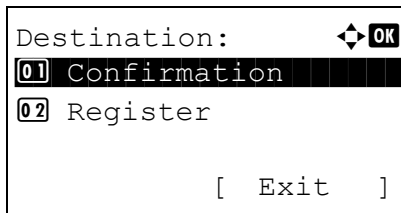

2 Press the **OK** key. The Destination menu appears.

Confirming Current Destination

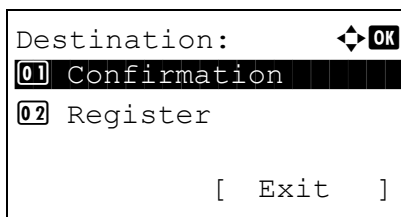

1 In the Destination menu, press the Δ or ∇ key to select [Confirmation].

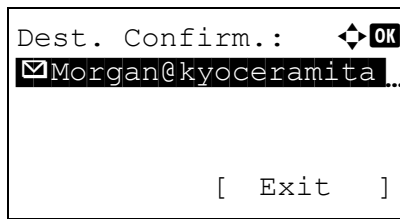

- 2 Press the **OK** key. Dest. Confirm. appears.

NOTE: Press the **OK** key to edit/delete the current destination. Refer to *Character Entry Method on Appendix-5* for details on entering characters.

- 3 Press [Exit] (the **Right Select** key). The basic screen reappears.

Registering Destination

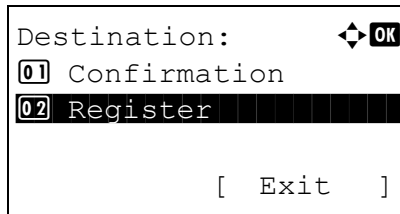

- 1 In the Destination menu, press the Δ or ∇ key to select [Register].

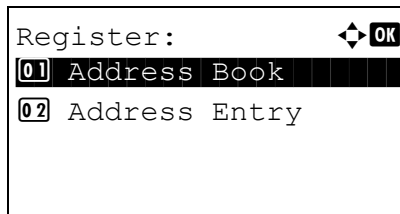

- 2 Press the **OK** key. Register appears.

To select a destination from the address book, press the Δ or ∇ key to select [Address Book] and then press the **OK** key. This displays the address book. Select your desired destination.

NOTE: For selecting a destination from the address book, refer to *Specifying Destination on page 3-28*.

To directly enter a destination, press the Δ or ∇ key to select [Address Entry] and then press the **OK** key. This displays an entry screen. Enter the destination address directly.

- 3 Press the **OK** key. *Completed.* is displayed and the screen returns to the Destination menu.

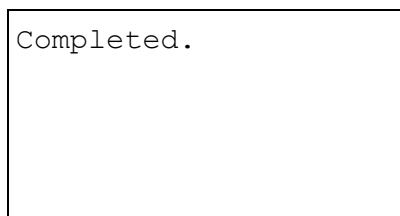

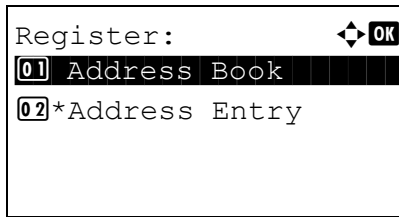

NOTE: If the address of the selected destination has been changed after you selected the destination from the address book, [*] is displayed before [Address Entry]. Refer to *Confirming Current Destination on page 7-14* and reconfirm the destination address.

Automatic Job Log History Transmission

This function automatically sends the job log history to the specified destinations whenever a set number of jobs has been logged.

Use the procedure below to set automatic job log history transmission.

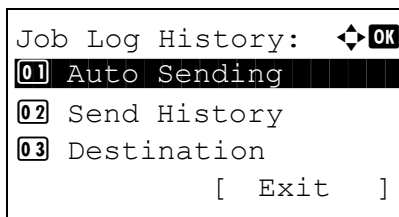

1 In the Job Log History menu, press the Δ or ∇ key to select [Auto Sending].

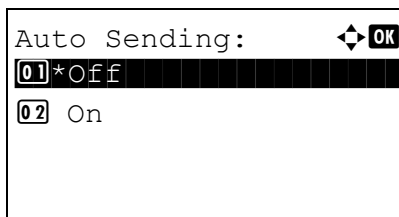

2 Press the **OK** key. Auto Sending appears.

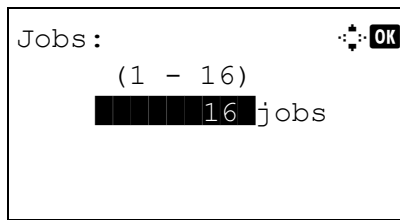

- Press the Δ or ∇ key to select [Off] or [On].

If you select [On] and press the **OK** key, Jobs appears. Use the numeric keys to enter the number of jobs to be sent at a time.

- Press the **OK** key. *Completed.* is displayed and the screen returns to the Job Log History menu.

Manual Job Log History Transmission

You can also send the job log history to the specified destinations manually.

Use the procedure below to send the job log history manually.

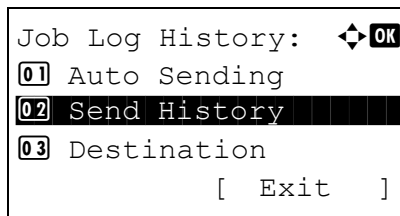

- In the Job Log History menu, press the Δ or ∇ key to select [Send History].

7

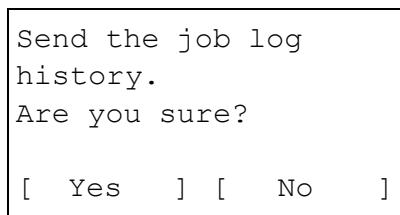

- Press the **OK** key. A confirmation screen appears.

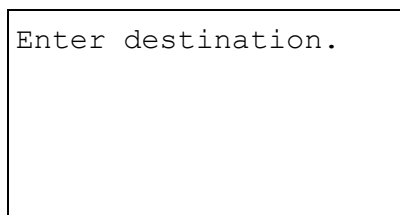

IMPORTANT: If no destination is registered, Enter destination is displayed. Refer to *Registering Destination on page 7-15* and register the desired destination.

- Press [Yes] (the **Left Select** key). Accepted. is displayed and the job log is sent to the registered destination before the screen returns to the Job Log History menu.

Setting E-mail Subject

Set the subject automatically entered when sending job log histories by e-mail.

Use the procedure below to set the subject.

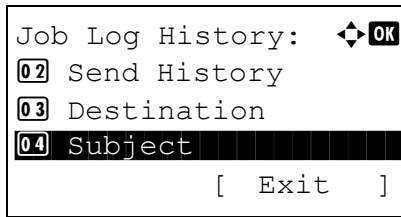

1 In the Job Log History menu, press the Δ or ∇ key to select [Subject].

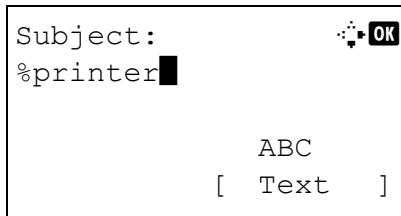

2 Press the **OK** key. Subject appears.

NOTE: Refer to *Character Entry Method on Appendix-5* for details on entering characters.

3 Enter the destination address.

4 Press the **OK** key. *Completed.* is displayed and the screen returns to the Job Log History menu.



Pause and Resumption of Jobs

Pause /resume all printing jobs in printing/waiting.



The procedure for pausing and resuming jobs is explained below.

```
Status: ⏏ OK
01 Print Job Status
02 Send Job Status
03 Store Job Status
[ Pause ]
```

- 1 Press the **Status/Job Cancel** key. The Status menu appears.

```
Print Job Status: ⏏ OK
0008  Copy
0009  maury's data
0010  aaaa
[ Pause ] [ Menu ]
```

- 2 Press the Δ or ∇ key to select [Print Job Status].
- 3 Press the **OK** key. Print Job Status appears.

```
Pausing: ⏏ OK
0008  Copy ||
0009  maury's data ||
0010  aaaa ||
[ Resume ] [ Menu ]
```

- 4 Press [Pause] (the **Left Select** key). Printing is paused.

When you press [Resume] (the **Left Select** key) to resume printing.

```
Resume paused jobs.
Are you sure?

[ Yes ] [ No ]
```

NOTE: When you press the **Back** key, a confirmation screen appears. Press [Yes] (the **Left Select** key) to resume printing.

Canceling of Jobs

For canceling jobs, refer to *Canceling Jobs* on page 3-31.

Device/Communication

Configure the devices/lines installed or connected to this machine or check their status. You can also control devices depending on their status.

Check of Device Status

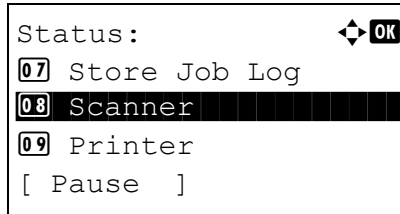

1 Press the **Status/Job Cancel** key. The Status menu appears.

2 Press the Δ or ∇ key to select [Scanner], [Printer] or [FAX].

3 Press the **OK** key. This displays the status of the device selected in step 2.

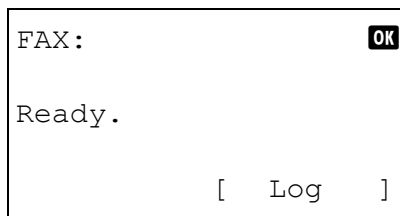
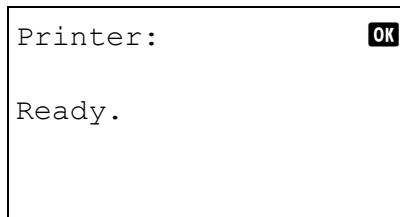
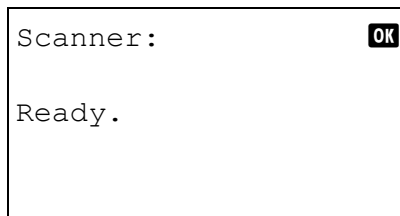

4 Press the **OK** key. The screen returns to the Status menu.

The items you can check are described below.

Scanner

The information (scanning, pausing, etc.) is displayed.

Printer

Information (waiting, printing, etc.) is displayed.

FAX

The information (sending, waiting, etc.) is displayed.

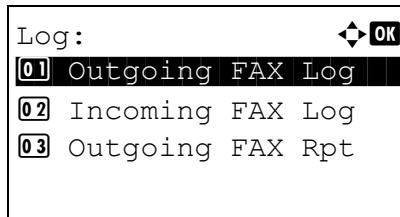

If you press [Log] (the **Right Select** key), the Log menu appears. From this screen, you can check or print the transmission/reception history.

NOTE: If you are using a user management function, the menu for printing the transmission/reception history appears only when you have logged in as an administrator.

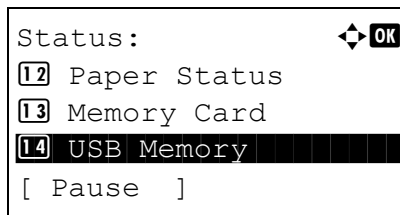
Handling the Devices

1 Press the **Status/Job Cancel** key. The Status menu appears.

2 Press the Δ or ∇ key to select [USB Memory].

3 Press the **OK** key. This displays the status of the USB memory.

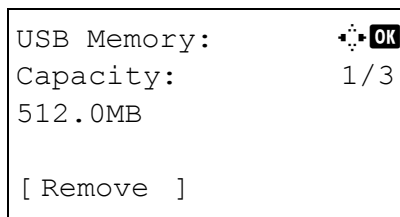

Press the \triangleleft or \triangleright key to switch the display to other information items. The items displayed are as follows:

Capacity
Used Area
Free Space

When you press [Remove] (the **Left Select** key), a confirmation screen appears and you can remove the USB memory.

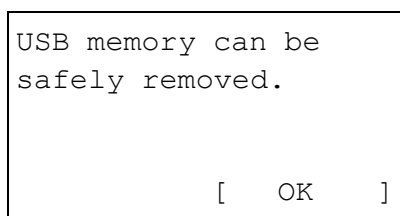

4 Press the **OK** key. The screen returns to the Status menu.

8 Default Setting (System Menu)

This chapter explains how to configure various settings of the machine using the menus on the operation panel.

- Common Settings8-2
- Copy Settings.....8-56
- Sending Settings.....8-62
- Document Box Settings8-66
- Printer Settings8-69
- Printing Reports/Sending Notice.....8-81
- Adjustment/Maintenance8-87
- Date/Timer8-92
- Editing Destination (Address Book/Adding One-Touch Keys). 8-112
- Restarting the System.....8-127
- Network Setup8-128
- Network Security.....8-138
- Interface Block Setting8-146
- Security Level (Security Level setting).....8-150
- Optional Functions.....8-151

Common Settings

Common settings include;

- How to display the Sys. Menu/Count. menu ...8-2
- Switching the Language for Display [Language] ...8-2
- Default Screen ...8-5
- Sound ...8-6
- Display Bright. ...8-7
- Original/Paper Settings ...8-8
- Switching Unit of Measurement ...8-27
- Error Handling ...8-28
- Function Defaults ...8-30
- Login Operation ...8-55

How to display the Sys. Menu/Count. menu

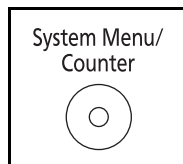

- 1 Press the **System Menu/Counter** key on the main unit operation panel.

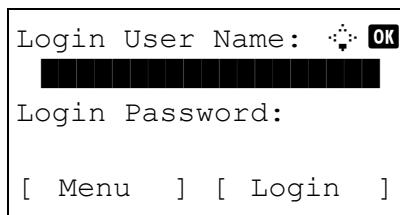

When you are performing user management and have not logged in, a login screen will appear. Then, enter the user ID and password to log in.

NOTE:

- Refer to *Character Entry Method on Appendix-5* for details on entering characters.
 - If [Netwk Authentic.] is selected as the user authentication method, press [Menu] (the **Left Select** key) to select the authentication destination.
-

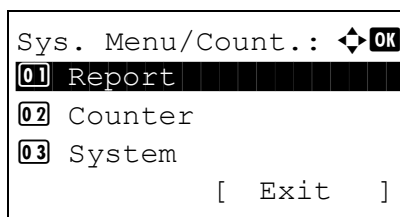

- 2 The Sys. Menu/Count. menu appears.

Switching the Language for Display [Language]

You can select the language of the message display by following the procedure given below. You can optionally download messages in other languages. Contact your service technician for information.

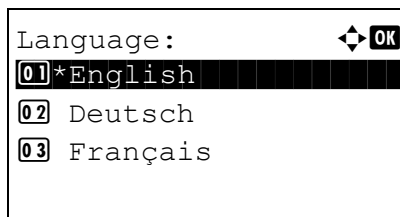
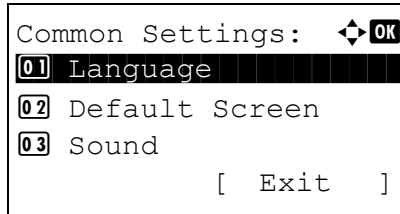
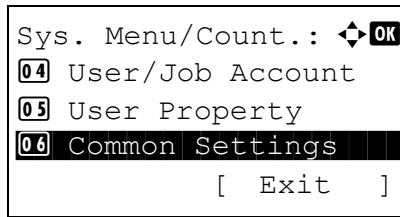

1 In the Sys. Menu/Count. menu, press the Δ or ∇ key to select [Common Settings].

2 Press the **OK** key. The Common Settings menu appears.

3 Press the Δ or ∇ key to select [Language].

4 Press the **OK** key. The Language menu appears.

The available languages are as follows:

- English
- Deutsch
- Français
- Español
- Italiano
- Nederlands
- Русский
- Português

The optional languages are as follows:

Optional language	Message display
Turkish	Türkçe
Greek	Ελληνικά
Polish	Polski
Czech	Čech
Hungarian	Magyar
Finnish	Suomi
Hebrew	אנגלית
Arabic	اربيك
Swedish	Svensk
Danish	Dansk
Norwegian	Norsk
Romanian	Român

Optional language	Message display
Korean	한국어
Simplified Chinese	简体中文
Traditional Chinese	繁體中文

If you are using one of the optional languages, it is displayed in place of Portugues.

- 5 Press the Δ or ∇ key to select a language.
- 6 Press the **OK** key. *Completed.* is displayed and the screen returns to the Common Settings menu.

Default Screen

Select the screen appearing right after start-up (default screen). The options are as follows.

The table below lists the available screens.

Item	Description
Status	The Status/Job Cancel screen (the screen shown when the Status/Job Cancel key is pressed) appears.
Copy	The Copy screen (the screen shown when the Copy key is pressed) appears.
Send	The Send screen (the screen shown when the Send key is pressed) appears.
FAX	The FAX screen (the screen shown when the FAX key is pressed) appears.
Document Box	The Document Box screen (the screen shown when the Document Box key is pressed) appears.

8

Use the procedure below to select the default startup screen.

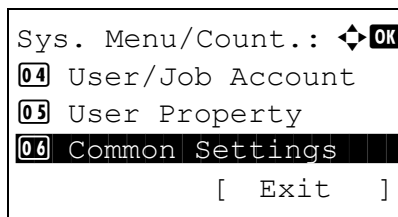

- 1 In the Sys. Menu/Count. menu, press the Δ or ∇ key to select [Common Settings].

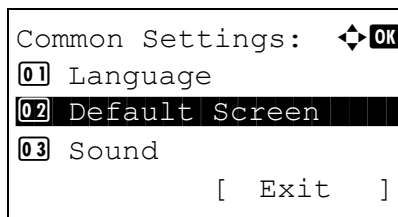

- 2 Press the **OK** key. The Common Settings menu appears.
- 3 Press the Δ or ∇ key to select [Default Screen].

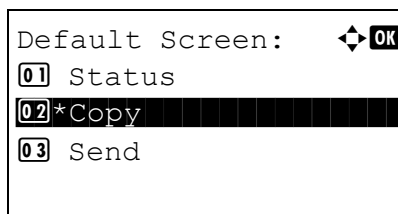

- 4 Press the **OK** key. Default Screen appears.
- 5 Press the Δ or ∇ key to select the default screen.
- 6 Press the **OK** key. *Completed.* is displayed and the screen returns to the Common Settings menu.

Sound

Set options for buzzer sound during the machine operations.

The table below lists the buzzer types and their settings and details. The asterisk in the table is a default setting.

Item	Value	Description
Key Confirmation	Off, On *	Emit a sound when the control panel are pressed.
Job Finish	Off*, On	Emit a sound when a print job is normally completed.
Ready	Off*, On	Emit a sound when the warm-up is completed.
Warning	Off, On*	Emit a sound when errors occur.

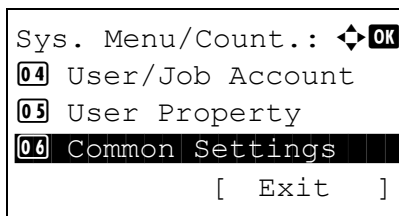

1 In the Sys. Menu/Count. menu, press the Δ or ∇ key to select [Common Settings].

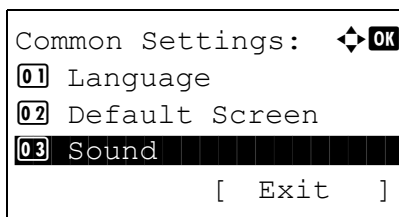

2 Press the **OK** key. The Common Settings menu appears.

3 Press the Δ or ∇ key to select [Sound].

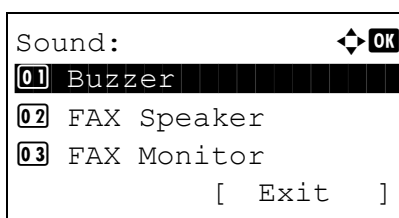

4 Press the **OK** key. Sound appears.

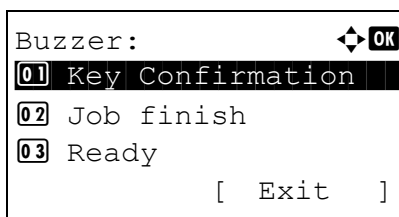

5 Press the Δ or ∇ key to select [Buzzer].

6 Press the **OK** key. Buzzer appears.

7 Press the Δ or ∇ key to select [Key Confirmation].

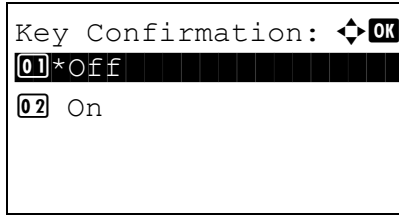

- 8 Press the **OK** key. Key Confirmation appears.
- 9 Press the Δ or ∇ key to select [On] or [Off].
- 10 Press the **OK** key. *Completed.* is displayed and the screen returns to the Buzzer menu.

Display Bright.

Set the brightness of the display.

Use the procedure below to adjust the display brightness.

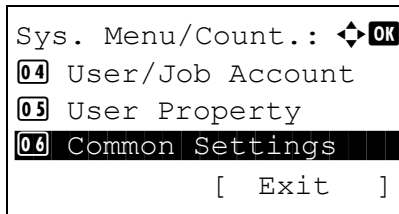

- 1 In the Sys. Menu/Count. menu, press the Δ or ∇ key to select [Common Settings].

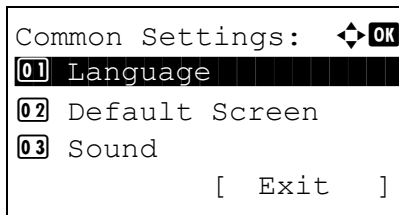

- 2 Press the **OK** key. The Common Settings menu appears.

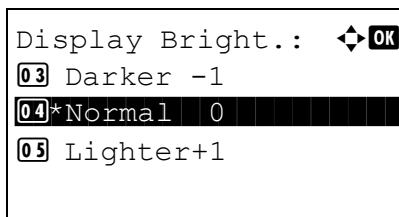

- 3 Press the Δ or ∇ key to select [Display Bright.].
- 4 Press the **OK** key. Display Bright. appears.
- 5 Press the Δ or ∇ key to select the display brightness from [Darker -3] to [Lighter +3].
- 6 Press the **OK** key. *Completed.* is displayed and the screen returns to the Common Settings menu.

Original/Paper Settings

Register additional types and sizes of originals and paper.

Custom Original Size Setup

Set up frequently-used custom original size. The dimensions available are as follows.

The table below lists the sizes that can be registered.

Input units	Dimensions
Inch models	X: 1.97 to 14.02" (in 0.01" increments) Y: 1.97 to 8.50" (in 0.01" increments)
Metric models	X: 50 to 356 mm (in 1 mm increments) Y: 50 to 216 mm (in 1 mm increments)

Use the procedure below to set a custom original size.

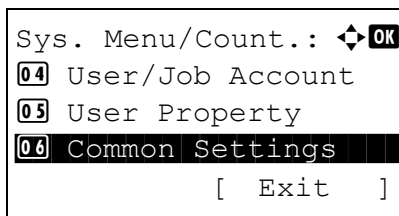

1 In the Sys. Menu/Count. menu, press the Δ or ∇ key to select [Common Settings].

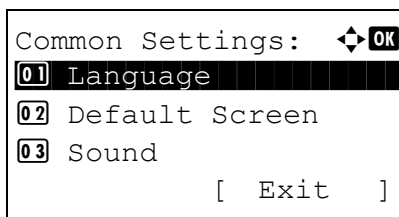

2 Press the **OK** key. The Common Settings menu appears.

3 Press the Δ or ∇ key to select [Orig./Paper Set.].

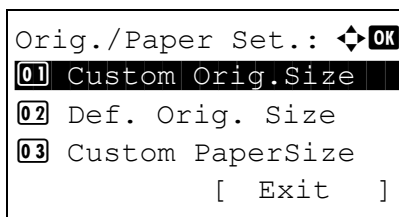

4 Press the **OK** key. The Orig./Paper Set. menu appears.

5 Press the Δ or ∇ key to select [Custom Orig.Size].

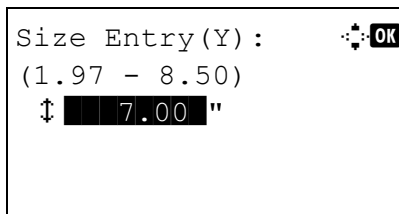

6 Press the **OK** key. Size Entry(Y) appears.

7 Use the numeric keys to enter the paper length (Y).

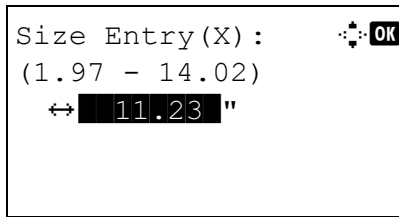

8 Press the **OK** key. Size Entry(X) appears.

9 Use the numeric keys to enter the paper width (X).

10 Press the **OK** key. *Completed.* is displayed and the screen returns to the Orig./Paper Set. menu.

Default Original Size Setup

In the screen for setting the paper size for the paper feed cassette or multi purpose tray, select the paper size to be used as the default value.

Use the procedure below to select the paper size to be used as the default value.

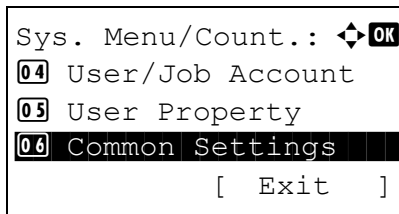

- 1 In the Sys. Menu/Count. menu, press the Δ or ∇ key to select [Common Settings].

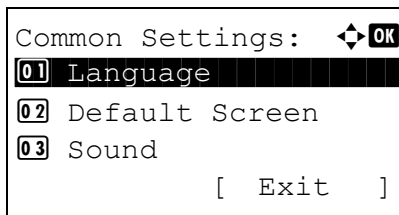

- 2 Press the **OK** key. The Common Settings menu appears.

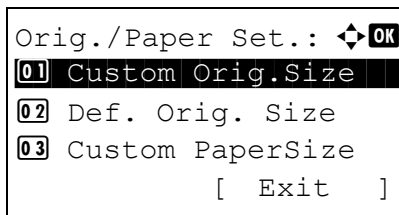

- 3 Press the Δ or ∇ key to select [Orig./Paper Set.].

- 4 Press the **OK** key. The Orig./Paper Set. menu appears.

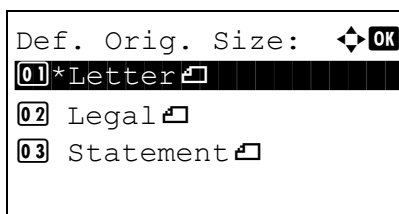

- 5 Press the Δ or ∇ key to select [Def. Orig. Size].

- 6 Press the **OK** key. Def. Orig. Size appears.

- 7 Press the Δ or ∇ key to select the paper size to be used as the default value.

- 8 Press the **OK** key. *Completed.* is displayed and the screen returns to the Orig./Paper Set. menu.

Adding a Custom Size and Media Type for Paper to Print

Set up a frequently-used custom paper size. The custom size options are displayed on the screen to select paper.

The table below lists the sizes that can be registered.

Input units	Dimensions	
Inch models	Cassette:	X: 4.13 to 8.50" (in 0.01" increments) Y: 5.83 to 14.02" (in 0.01" increments)
	Paper Feeder PF-100:	X: 5.83 to 8.50" (in 0.01" increments) Y: 8.27 to 14.02" (in 0.01" increments)
	MP Tray:	X: 2.75 to 8.50" (in 0.01" increments) Y: 5.83 to 14.02" (in 0.01" increments)
Metric models	Cassette:	X: 105 to 216 (in 1 mm increments) Y: 148 to 356 (in 1 mm increments)
	Paper Feeder PF-100:	X: 148 to 216 (in 1 mm increments) Y: 210 to 356 (in 1 mm increments)
	MP Tray:	X: 70 to 216 (in 1 mm increments) Y: 148 to 356 (in 1 mm increments)

Custom paper sizes can be added for each paper source.

Select media type for each paper size.

Media type: Plain, Transparency, Rough, Vellum, Labels, Recycled, Preprinted, Bond, Cardstock, Color, Prepunched, Letterhead, Thick, Envelope, High Quality, Custom 1-8

NOTE: Refer to *Paper Weight* on page 8-17 for Custom 1-8 for media type.

Use the procedure below to select a custom paper size and media type.

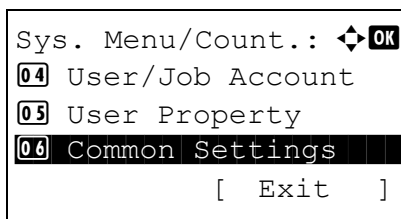

1 In the Sys. Menu/Count. menu, press the Δ or ∇ key to select [Common Settings].

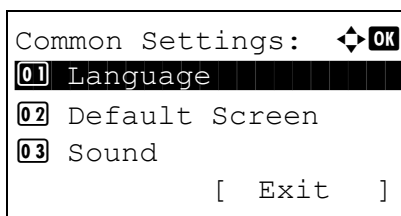

2 Press the **OK** key. The Common Settings menu appears.

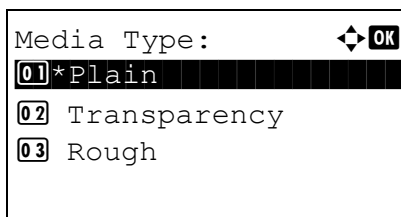
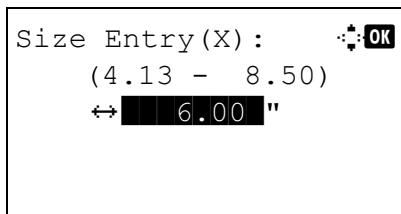
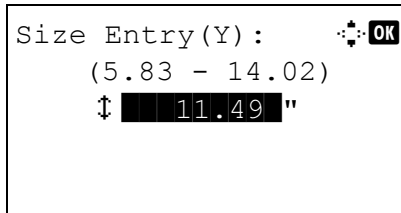
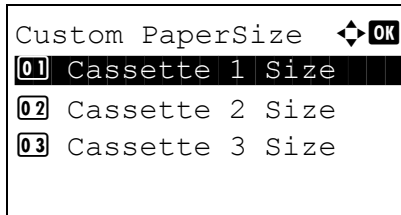
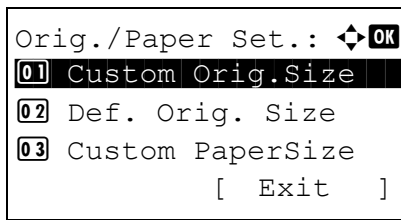

- 3 Press the Δ or ∇ key to select [Orig./Paper Set.].
- 4 Press the **OK** key. The Orig./Paper Set. menu appears.
- 5 Press the Δ or ∇ key to select [Custom PaperSize].
- 6 Press the **OK** key. The Custom PaperSize menu appears.
- 7 Select the paper source in which you want to set the custom size and press the **OK** key. Size Entry(Y) appears.
- 8 Use the numeric keys to enter the paper length (Y).
- 9 Press the **OK** key. Size Entry(X) appears.
- 10 Use the numeric keys to enter the paper width (X).
- 11 Press the **OK** key. Mediatype appears.
- 12 Press the Δ or ∇ key to select the media type for which you want to set the custom size.
- 13 Press the **OK** key. *Completed.* is displayed and the screen returns to the Orig./Paper Set. menu.

Paper Size and Media Type Setup for Cassettes

Select paper size and media type for Cassette 1 and optional paper feeders (Cassette 2 and 3).

The available paper sizes and media types are shown in the table below.

Item	Description
Paper Size	Letter, Legal, Statement*, Executive, Oficio II, A4, A5, A6*, B5, Folio, 16K, Custom
Media Type	Plain (105 g/m ² or less), Rough, Vellum (64 g/m ² or less), Recycled, Preprint***, Bond**, Color, Prepunched***, Letterhead***, Thick (106 g/m ² and more)**, High Quality, Custom 1-8**

* Cassette 1 only

** To change to a media type other than *Plain*, refer to *Paper Weight* on page 8-17.

*** To print on preprinted or prepunched paper or on letterhead, refer to *Special Paper Action* on page 8-24.

Use the procedure below to select the paper size and media type for each cassette.

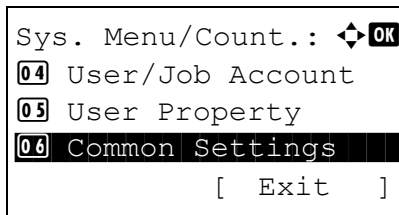

1 In the Sys. Menu/Count. menu, press the Δ or ∇ key to select [Common Settings].

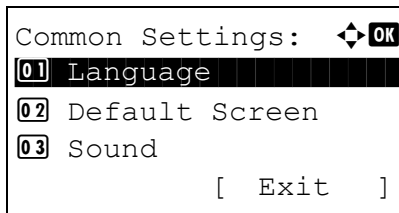

2 Press the **OK** key. The Common Settings menu appears.

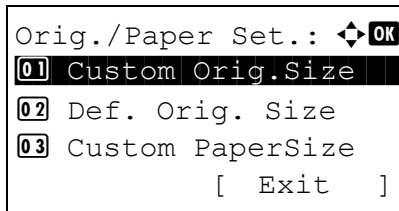

3 Press the Δ or ∇ key to select [Orig./Paper Set.].

4 Press the **OK** key. The Orig./Paper Set. menu appears.

5 Press the Δ or ∇ key to select [Cassette 1 Set.], [Cassette 2 Set.] or [Cassette 3 Set.].

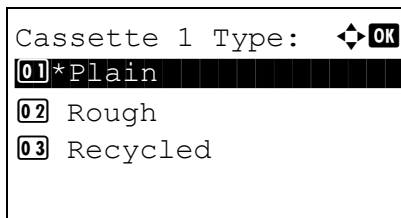
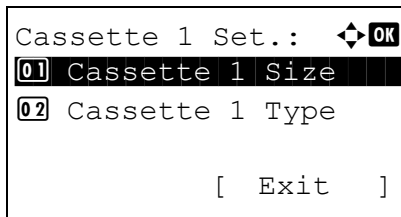
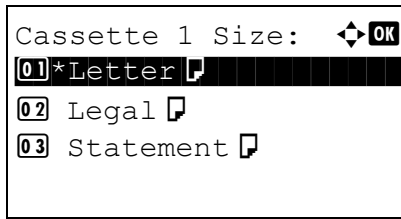
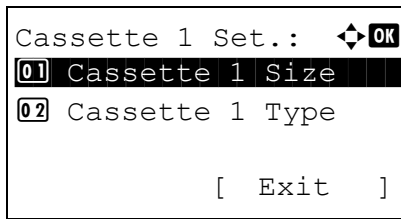

Follow the steps below when you select the main unit cassette ([Cassette 1]). Operate in a similar fashion when you select an optional cassette ([Cassette 2 or 3])

- 6 The Cassette 1 Set. menu appears.
- 7 Press the Δ or ∇ key to select [Cassette 1 Size].
- 8 Press the **OK** key. Cassette 1 Size appears.
- 9 Press the Δ or ∇ key to select the paper size.
- 10 Press the **OK** key. The screen returns to the Cassette 1 Set. menu.
- 11 Press the Δ or ∇ key to select [Cassette 1 Type].
- 12 Press the **OK** key. Cassette 1 Type appears.
- 13 Press the Δ or ∇ key to select the paper type.
- 14 Press the **OK** key. *Completed.* is displayed and the screen returns to the Cassette 1 Set. menu.

Paper Size and Media Type Setup for Multi Purpose Tray

Select size and media type for multi purpose tray. Set up frequently-used size and media type before use.

The available paper sizes and media types are shown in the table below.

Item		Description
Paper Size	Standard Sizes	Letter, Legal, Statement, Executive, Oficio II, A4, A5, A6, B5, B6, Folio, 16K
	Others	Select special standard sizes or custom size*. ISO B5, Envelope #10, Envelope #9, Envelope #6, Envelope Monarch, Envelope DL, Envelope C5, Hagaki, Oufuku Hagaki, Youkei 4, Youkei 2, Custom
	Size Entry	Enter a size not displayed in the standard sizes. Inch models: X: 2.75 to 8.50" (in 0.01" increments) Y: 5.83 to 14.02" (in 0.01" increments) Metric models: X: 70 to 216 (in 1 mm increments) Y: 148 to 356 (in 1 mm increments)
Media Type		Plain (105 g/m ² or less), Transparency, Rough, Vellum (64 g/m ² or less), Labels, Recycled, Preprinted**, Bond, Cardstock, Color, Prepunched**, Letterhead**, Envelope, Thick (106 g/m ² and more), High Quality, Custom 1-8**

* Refer to *Adding a Custom Size and Media Type for Paper to Print on page 8-11* for selecting Custom Paper Size.

** Refer to *Paper Weight on page 8-17* for selecting Custom 1- 8 from Media Type.
To print on preprinted or prepunched paper or on letterhead, refer to *Special Paper Action on page 8-24*.

NOTE: To change to a media type other than *Plain*, refer to *Paper Weight on page 8-17*

Use the procedure below to select the paper size and media type for manual paper feed.

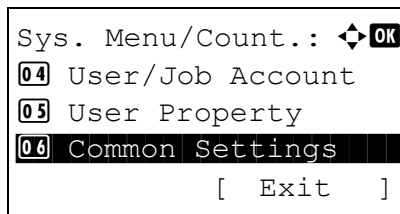

- 1 In the Sys. Menu/Count. menu, press the Δ or ∇ key to select [Common Settings].

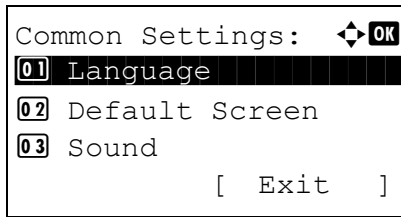

2 Press the **OK** key. The Common Settings menu appears.

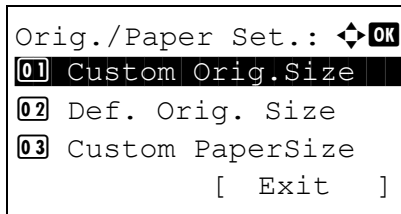

3 Press the Δ or ∇ key to select [Orig./Paper Set.].

4 Press the **OK** key. The Orig./Paper Set. menu appears.

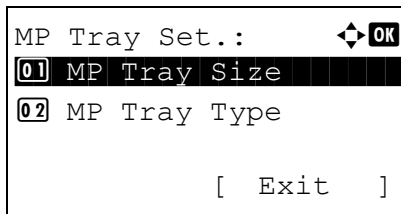

5 Press the Δ or ∇ key to select [MP Tray Set.].

6 Press the **OK** key. The MP Tray Set. menu appears.

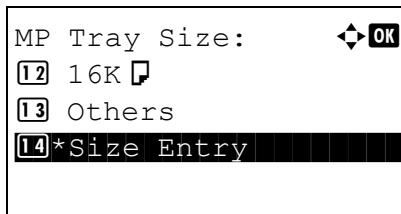

7 Press the Δ or ∇ key to select [MP Tray Size].

8 Press the **OK** key. MP Tray Size appears.

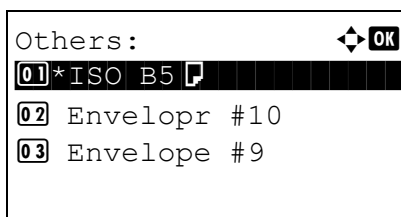

9 Press the Δ or ∇ key to select the paper size.

If you select [Others], you can select from additional paper sizes.

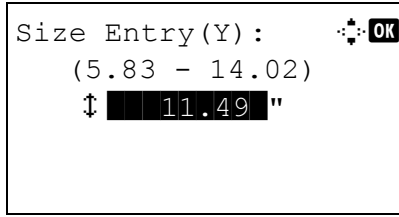

If you select [Size Entry], you can register a custom size. In the screen that appears, set the vertical size (Y) and horizontal size (X) of the paper using the numeric keys.

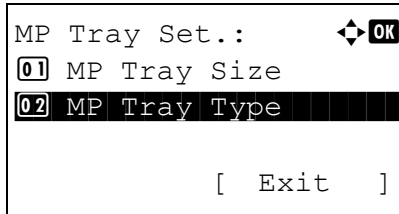

10 Press the **OK** key. The screen returns to the MP Tray Set. menu.

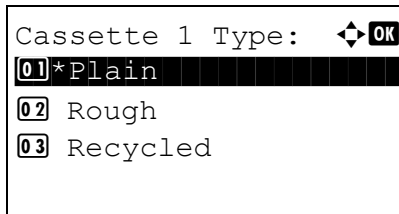

11 Press the Δ or ∇ key to select [MP Tray Type].

12 Press the **OK** key. MP Tray Type appears.

13 Press the Δ or ∇ key to select the paper type.

14 Press the **OK** key. *Completed.* is displayed and the screen returns to the MP Tray Set. menu.

Paper Weight

Select weight for each media type. The options for media type and weight of paper are as follows.

Paper types and weights

●: Available ×: Not available

Paper Weight	Light	Normal 1	Normal 2	Normal 3	Heavy 1	Heavy 2	Heavy 3	Extra Heavy
Plain	●	●	●	●**	×	×	×	×
Transparency	×	×	×	×	●	●	●	●
Rough	●	●	●	●	●	●	●	×
Vellum	●	●	●	●	×	×	×	×
Labels	●	●	●	●	●	●	●	●
Recycled	●	●	●	●	×	×	×	×
Preprinted	●	●	●	●	×	×	×	×
Bond	●	●	●	●	●	●	●	×

Paper Weight	Light	Normal 1	Normal 2	Normal 3	Heavy 1	Heavy 2	Heavy 3	Extra Heavy
Cardstock	x	x	x	x	●	●	●	●
Color	●	●	●	●	x	x	x	x
Prepunched	●	●	●	●	x	x	x	x
Letterhead	●	●	●	●	x	x	x	x
Thick	x	x	x	x	●	●	●	●
Envelope	x	x	x	x	●	●	●	●
High Quality	●	●	●	●	x	x	x	x
Custom 1-8	●	●	●	●	●	●	●	●

For Custom 1-8, settings for duplex printing and media type name can be changed.

Item		Description
Duplex	Prohibit	Duplex printing not allowed.
	Permit	Duplex printing allowed.
Name		Change names for Custom 1-8. Names should be not more than 16 characters. Selecting media type at multi purpose tray, the name after change will be displayed.

Use the procedure below to set the paper weight.

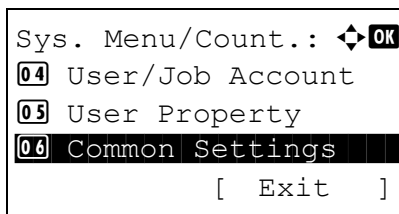

1 In the Sys. Menu/Count. menu, press the Δ or ∇ key to select [Common Settings].

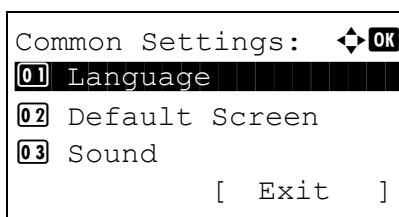

2 Press the **OK** key. The Common Settings menu appears.

3 Press the Δ or ∇ key to select [Orig./Paper Set.].

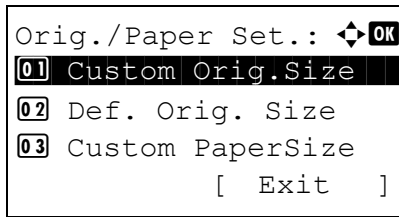

4 Press the **OK** key. The Orig./Paper Set. menu appears.

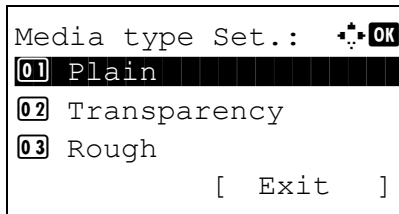

5 Press the Δ or ∇ key to select [Media Type Set.].

6 Press the **OK** key. Media Type Set. menu appears.

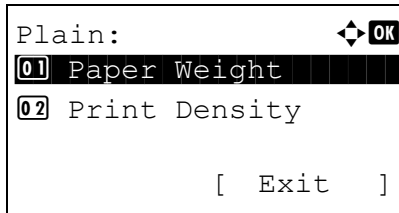

7 Press the Δ or ∇ key to select the paper type for which you want to make settings.

8 Press the **OK** key. The menu for the selected paper type appears.

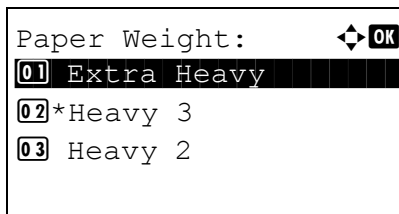

9 Press the Δ or ∇ key to select [Paper Weight].

10 Press the **OK** key. The Paper Weight menu appears.

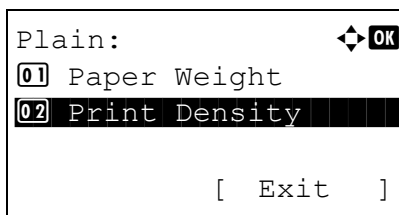

11 Press the Δ or ∇ key to select the weight of paper.

12 Press the **OK** key. *Completed.* is displayed and the screen returns to the menu for the selected paper type.

13 Press the Δ or ∇ key to select [Print Density].

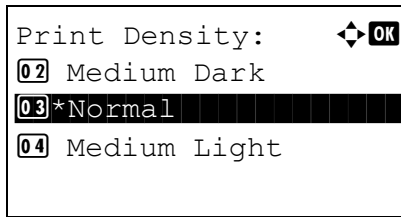

14 Press the **OK** key. The Print Density menu appears.

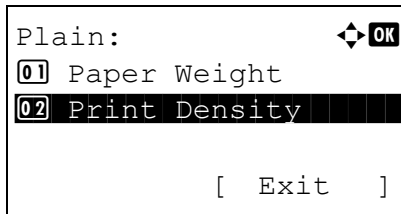

15 Press the Δ or ∇ key to select the print density.

16 Press the **OK** key. *Completed.* is displayed and the screen returns to the menu for the selected paper type.

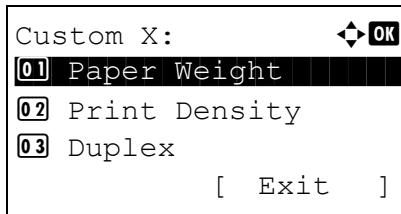

When the selected paper type is [Custom 1 to 8], you can further set whether to enable or disable duplex and the name of the custom paper type.

17 Press the Δ or ∇ key to select [Duplex].

18 Press the **OK** key. The Duplex menu appears.

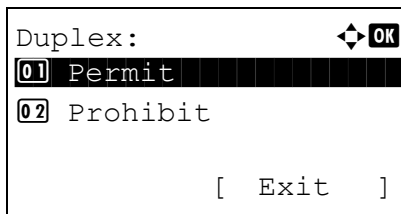

19 Press the Δ or ∇ key to select whether to enable or disable duplex.

20 Press the **OK** key. *Completed.* is displayed and the screen returns to the menu for the selected custom paper type.

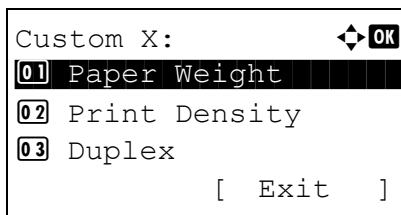

21 Press the Δ or ∇ key to select [Name].

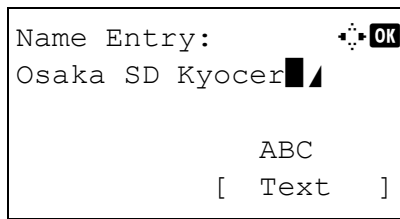

22 Press the **OK** key. Name Entry is displayed.

Enter the name of the custom paper type.

NOTE: Refer to *Character Entry Method on Appendix-5* for details on entering characters.

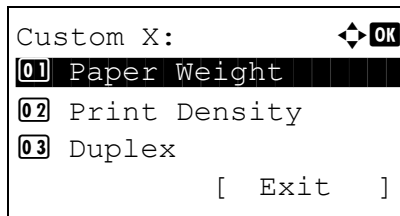

23 Press the **OK** key. *Completed.* is displayed and the screen returns to the menu for the selected custom paper type.

Default Paper Source

Select the default paper source from Cassette 1-3 and Multi Purpose Tray.

NOTE: [Cassette 2] and [Cassette 3] are displayed when the optional side feeder installed.

Use the procedure below to select the default paper source.

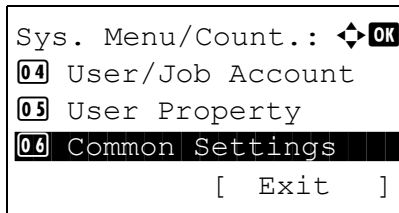

1 In the Sys. Menu/Count. menu, press the Δ or ∇ key to select [Common Settings].

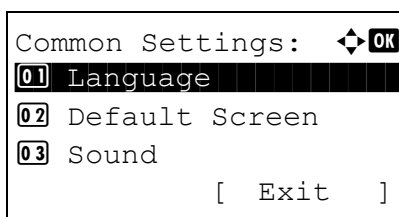

2 Press the **OK** key. The Common Settings menu appears.

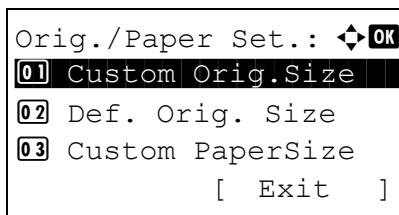

3 Press the Δ or ∇ key to select [Orig./Paper Set.].

4 Press the **OK** key. The Orig./Paper Set. menu appears.

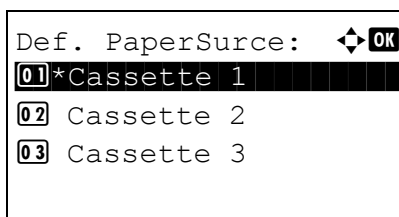

5 Press the Δ or ∇ key to select [Def. PaperSource].

6 Press the **OK** key. Def. PaperSource appears.

7 Press the Δ or ∇ key to select the paper source to be used preferentially.

8 Press the **OK** key. *Completed.* is displayed and the screen returns to the Common Settings menu.

Media for Auto Selection

When [Auto] is selected in Paper Selection, the paper source that is automatically selected can be limited by media types. If *Plain* is selected, the paper source with plain paper loaded in the specific size is selected. Select [All Media Types] for the paper source with any kind of paper loaded in the specific size.

Use the procedure below to select the paper size and media type used by Auto Selection.

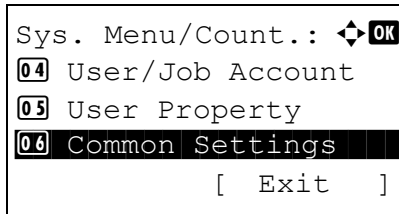

- 1 In the Sys. Menu/Count. menu, press the Δ or ∇ key to select [Common Settings].

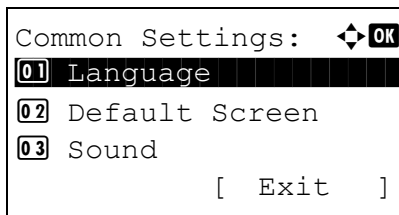

- 2 Press the **OK** key. The Common Settings menu appears.

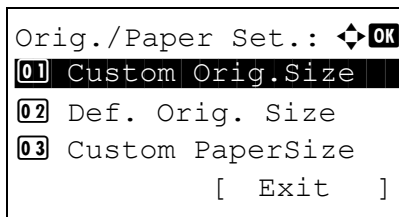

- 3 Press the Δ or ∇ key to select [Orig./Paper Set.].
- 4 Press the **OK** key. The Orig./Paper Set. menu appears.

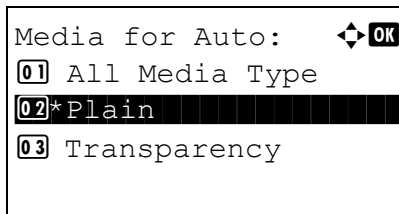

- 5 Press the Δ or ∇ key to select [Media for Auto].
- 6 Press the **OK** key. Media for Auto appears.
- 7 Press the Δ or ∇ key to select [All Media Type] or the paper type to be used for paper selection.
- 8 Press the **OK** key. *Completed.* is displayed and the screen returns to the Orig./Paper Set. menu.

Special Paper Action

When printing on Prepunched, Preprint, and Letterhead, punch-holes might not be aligned or the print direction might be upside-down depending on how originals are set and the combination of copying functions. In such a case, select [Adj. PrintDirect] to adjust the print direction. When paper orientation is not important, select [Speed Priority].

The table below lists the available settings and their details.

Item	Description
Adj. PrintDirect	Adjust print direction. Print speed is a little slower. Select this item to print on Prepunched, Preprint and Letterhead.
Speed Priority	Give the job speed top priority and disregard the paper orientation. Select this item when paper orientation is not important.

If you select [Adj. PrintDirect], load paper according to the steps below.

Example: copying on Letterhead

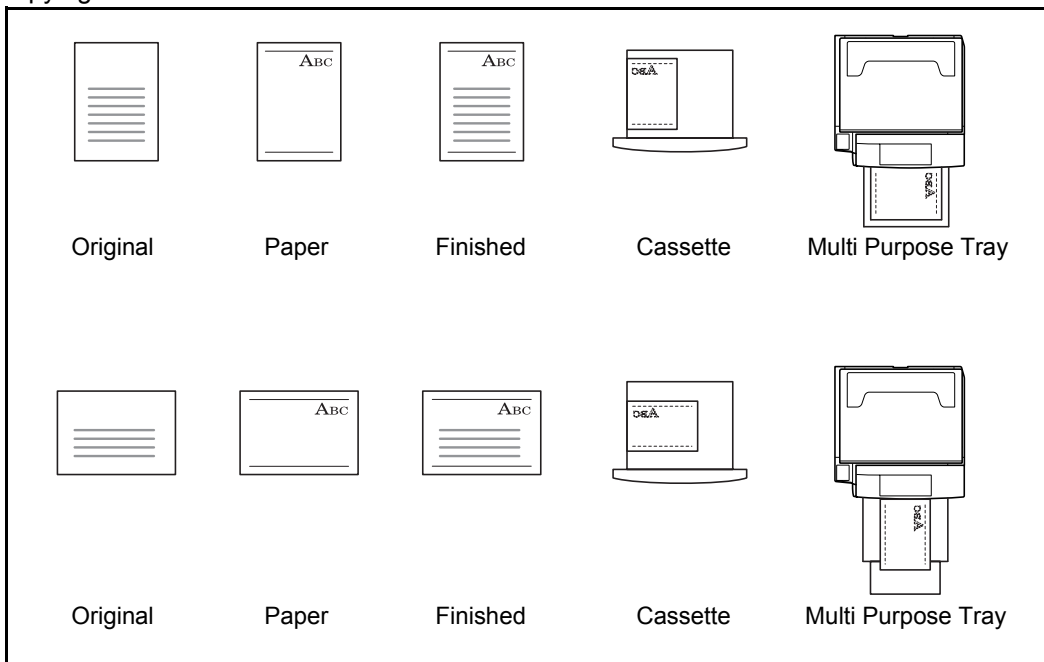

NOTE: When loading cover paper in a cassette or multi purpose tray, load the face, on which printing is supposed to be done, upward.

Use the procedure below to specify the actions performed for special paper types.

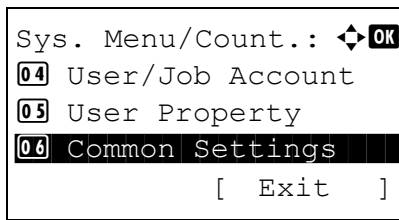

1 In the Sys. Menu/Count. menu, press the Δ or ∇ key to select [Common Settings].

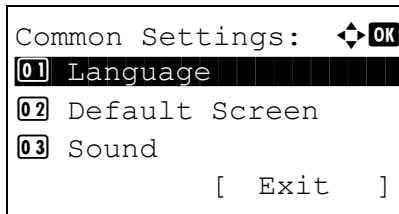

2 Press the **OK** key. The Common Settings menu appears.

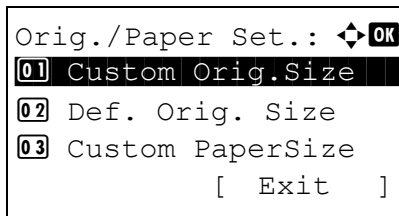

3 Press the Δ or ∇ key to select [Orig./Paper Set.].

4 Press the **OK** key. The Orig./Paper Set. menu appears.

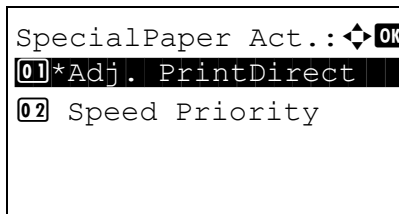

5 Press the Δ or ∇ key to select [SpecialPaper Act.].

6 Press the **OK** key. SpecialPaper Act. appears.

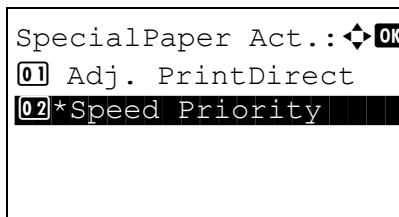

7 Press the Δ or ∇ key to select [Adj. PrintDirect] or [Speed Priority].

8 Press the **OK** key. *Completed.* is displayed and the screen returns to the Orig./Paper Set. menu.

Preset Limit

Restrict the number of copies that can be made at one time. Options are 1-999 copies.

Use the procedure below to set the limit on the number of copies.

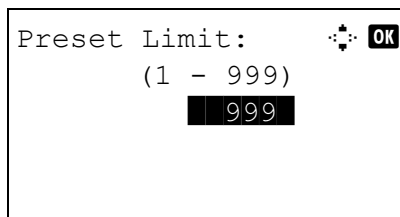
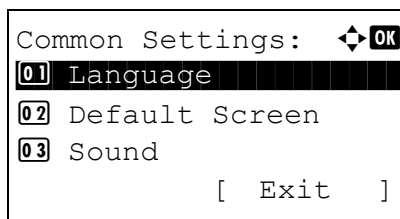
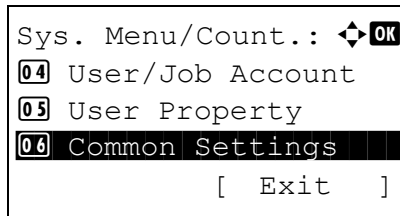

- 1 In the Sys. Menu/Count. menu, press the Δ or ∇ key to select [Common Settings].
- 2 Press the **OK** key. The Common Settings menu appears.
- 3 Press the Δ or ∇ key to select [Preset Limit].
- 4 Press the **OK** key. The Preset Limit menu appears.
- 5 Press the Δ or ∇ key to enter the number of copies.
- 6 Press the **OK** key. *Completed.* is displayed and the screen returns to the Common Settings menu.

Switching Unit of Measurement

Select inch or metric for the unit for paper dimensions.

Use the procedure below to change the input units.

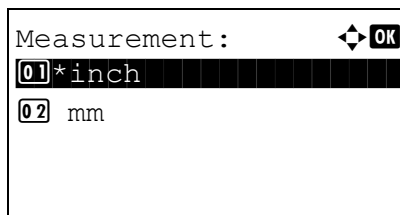
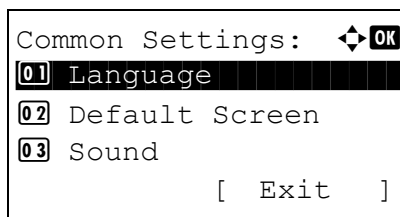
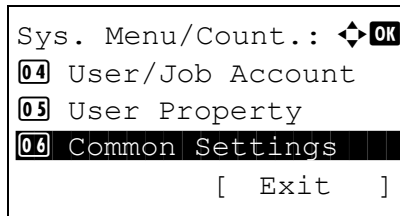

- 1 In the Sys. Menu/Count. menu, press the Δ or ∇ key to select [Common Settings].
- 2 Press the **OK** key. The Common Settings menu appears.
- 3 Press the Δ or ∇ key to select [Measurement].
- 4 Press the **OK** key. The Measurement menu appears.
- 5 Press the Δ or ∇ key to select [inch] or [mm].
- 6 Press the **OK** key. *Completed.* is displayed and the screen returns to the Common Settings menu.

Error Handling

Select whether to cancel or continue the job when error has occurred. The possible errors and what to do for the errors are as follows.

Duplexing Error

Select what to do when duplex printing is not possible for the selected paper size and media type.

Item	Description
1-sided	Printed in 1-sided
Display Error	Error message to cancel printing is displayed.

Paper Mismatch Error

Select the method to handle if the selected paper size or paper type does not match the paper size or paper type set in the paper source when printing from your computer.

Item	Description
Ignore	Printing continues.
Display Error	Error message to cancel printing is displayed.

Use the procedure below to specify the settings for error handling.

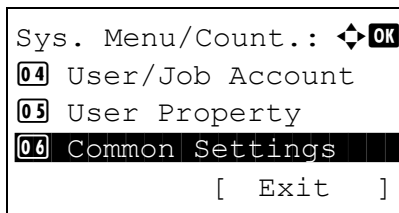

- 1 In the Sys. Menu/Count. menu, press the Δ or ∇ key to select [Common Settings].

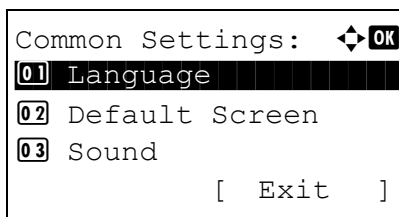

- 2 Press the **OK** key. The Common Settings menu appears.

- 3 Press the Δ or ∇ key to select [Error Handling].

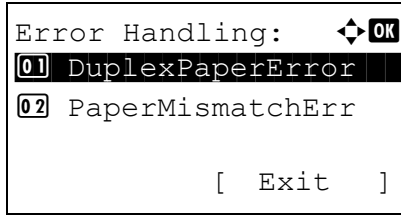

4 Press the **OK** key. The Error Handling menu appears.

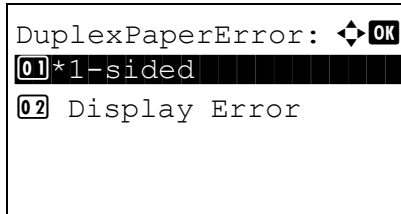

5 Press the Δ or ∇ key to select [DuplexPaperError].

6 Press the **OK** key. DuplexPaperError appears.

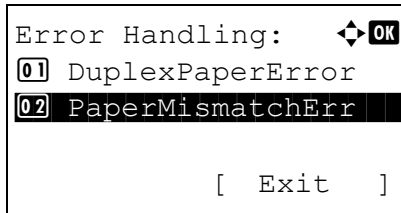

7 Press the Δ or ∇ key to select the method to handle if duplex is disabled.

8 Press the **OK** key. *Completed.* is displayed and the screen returns to the Error Handling menu.

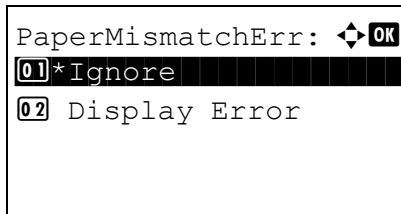

9 Press the Δ or ∇ key to select [PagerMismatchErr].

10 Press the **OK** key. PagerMismatchErr appears.

11 Press the Δ or ∇ key to select the method to handle paper mismatch.

12 Press the **OK** key. *Completed.* is displayed and the screen returns to the Error Handling menu.



Function Defaults

Defaults are the values automatically set after the warm-up is completed or the **Reset** key is pressed.

Set the defaults for available settings such as copying and sending. Setting the frequently-used values as defaults makes subsequent jobs easier.

Orig.Orientation

Set the original orientation defaults. The available default settings are shown below.

Item	Description
 Top Edge Top	Select the original's top edge at the top.
 Top Edge Left	Select the original's top edge at the left.

Refer to *page 4-8 for Original Orientation*.

Use the procedure below to select the default orientation when originals are placed on the platen.

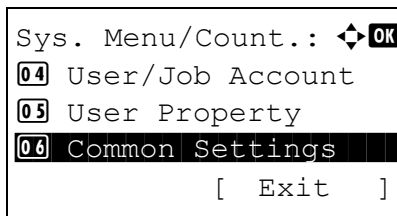

- 1 In the Sys. Menu/Count. menu, press the Δ or ∇ key to select [Common Settings].

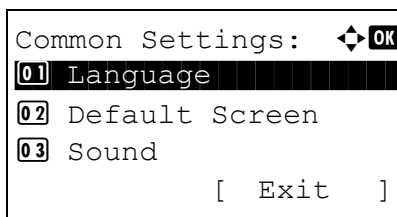

- 2 Press the **OK** key. The Common Settings menu appears.

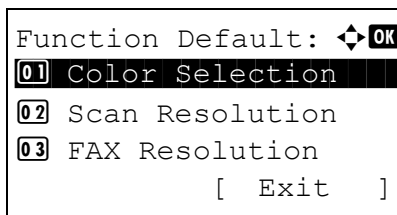

- 3 Press the Δ or ∇ key to select [Function Default].
- 4 Press the **OK** key. The Function Default menu appears.

- 5 Press the Δ or ∇ key to select [Orig.Orientation].

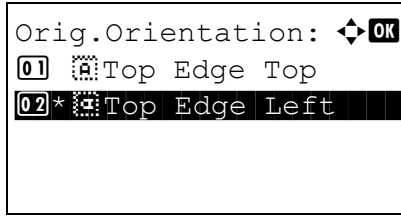

6 Press the **OK** key. Orig.Orientation appears.

7 Press the Δ or ∇ key to select [Top Edge Top] or [Top Edge Left] .

8 Press the **OK** key. *Completed.* is displayed and the screen returns to the Function Default menu.

Continuous Scan

Set the continuous scan defaults. The available default settings are shown below.

Item	Description
Off	Continuous scan not performed
On	Continuous scan performed

Refer to page 4-8 for Original Orientation.

Use the procedure below to select the default settings for continuous scanning.

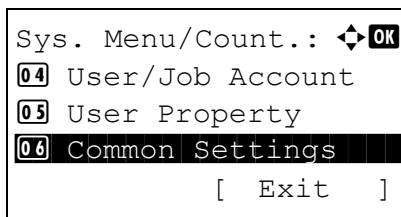

1 In the Sys. Menu/Count. menu, press the Δ or ∇ key to select [Common Settings].

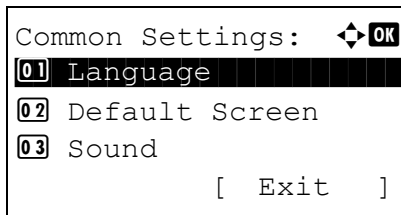

2 Press the **OK** key. The Common Settings menu appears.

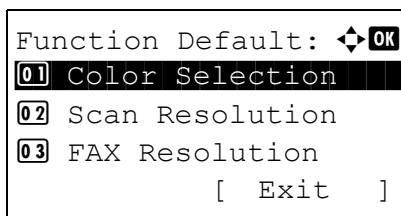

3 Press the Δ or ∇ key to select [Function Default].

4 Press the **OK** key. The Function Default menu appears.

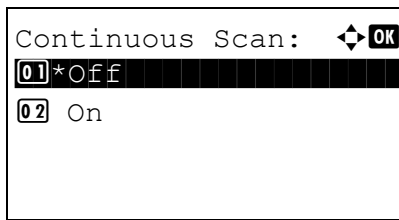

- 5 Press the Δ or ∇ key to select [Continuous Scan].
- 6 Press the **OK** key. Continuous Scan appears.
- 7 Press the Δ or ∇ key to select [Off] or [On].
- 8 Press the **OK** key. *Completed.* is displayed and the screen returns to the Function Default menu.

Original Image

Set the default original document type. The available default settings are shown below.

Item	Description
Text+Photo	Text and photos together.
Photo	For photos taken with a camera.
Text	Only text, no photos.
for OCR	Image quality suitable for OCR software.

Use the procedure below to select the default quality setting for originals.

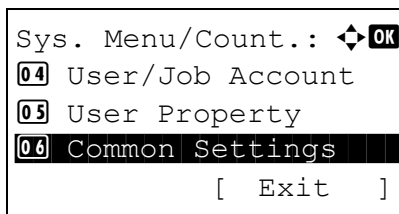

- 1 In the Sys. Menu/Count. menu, press the Δ or ∇ key to select [Common Settings].

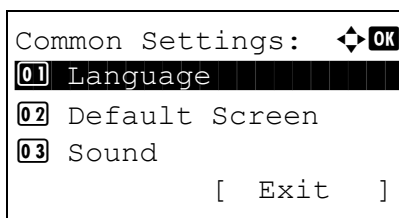

- 2 Press the **OK** key. The Common Settings menu appears.

- 3 Press the Δ or ∇ key to select [Function Default].

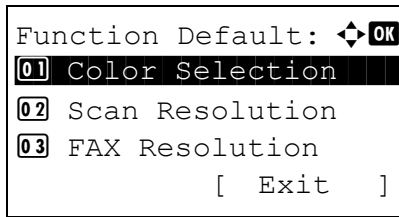

4 Press the **OK** key. The Function Default menu appears.

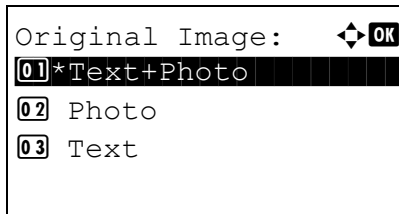

5 Press the Δ or ∇ key to select [Original Image].

6 Press the **OK** key. Original Image appears.

7 Press the Δ or ∇ key to select [Text+Photo], [Photo], [Text] or [for OCR].

8 Press the **OK** key. *Completed.* is displayed and the screen returns to the Function Default menu.

Scan Resolution

Select the default scanning resolution. The options are 600x600dpi, 400x400dpi U.Fin (Ultra Fine), 300x300dpi, 200x400dpi S.Fin (Super Fine), 200x200dpi Fine, 200x100dpi Norm. (Normal).

Use the procedure below to select the default resolution setting.

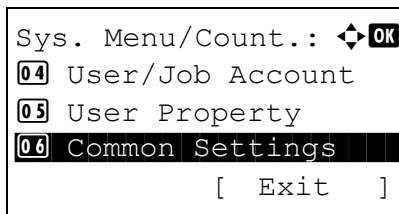

1 In the Sys. Menu/Count. menu, press the Δ or ∇ key to select [Common Settings].

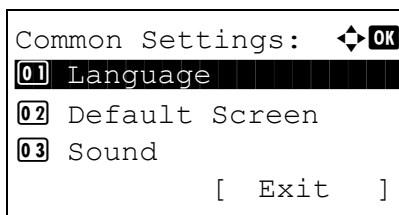

2 Press the **OK** key. The Common Settings menu appears.

3 Press the Δ or ∇ key to select [Function Default].

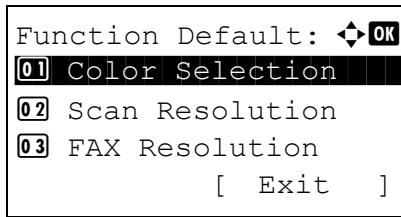

4 Press the **OK** key. The Function Default menu appears.

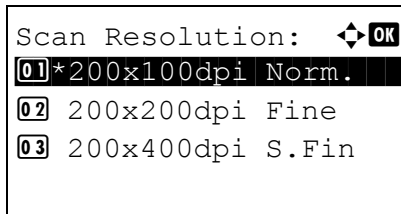

5 Press the Δ or ∇ key to select [Scan Resolution].

6 Press the **OK** key. Scan Resolution appears.

7 Press the Δ or ∇ key to select [200x100dpi Norm.], [200x200dpi Fine], [200x400dpi S.Fin], [300x300dpi], [400x400dpi U.Fin] or [600x600dpi].

8 Press the **OK** key. *Completed.* is displayed and the screen returns to the Function Default menu.

Color Selection

Select the default color mode setting. The available default settings are shown below.

Color mode	Description
Full Color	Scan document in full color.
Grayscale	Scan document in grayscale for smoother and finer finish.
Black & White	Scan document in black and white.

Use the procedure below to select the default color mode setting.

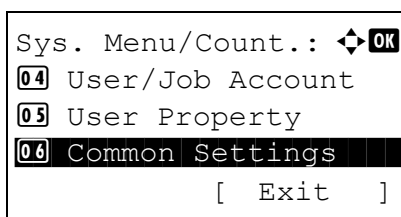

1 In the Sys. Menu/Count. menu, press the Δ or ∇ key to select [Common Settings].

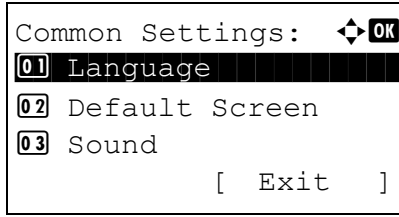

2 Press the **OK** key. The Common Settings menu appears.

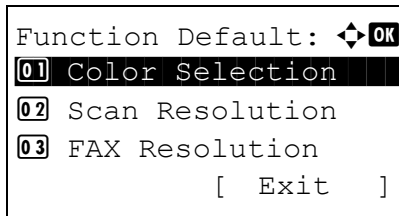

3 Press the Δ or ∇ key to select [Function Default].

4 Press the **OK** key. The Function Default menu appears.

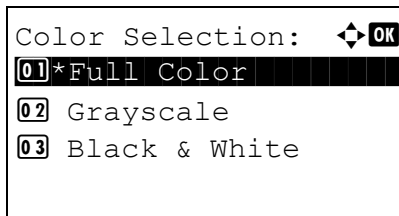

5 Press the Δ or ∇ key to select [Color Selection].

6 Press the **OK** key. Color Selection appears.

7 Press the Δ or ∇ key to select [Full Color], [Grayscale] or [Black & White].

8 Press the **OK** key. *Completed.* is displayed and the screen returns to the Function Default menu.

File Format

Select the default file type to send the scanned originals. The available default settings are shown below.

File Format	Description
PDF	Send files in PDF format.
TIFF	Send files in TIFF format.
XPS	Send files in XPS format.
JPEG	Send files in JPEG format.

NOTE: Refer to page 5-10 for file formats.

Use the procedure below to select the default file format.

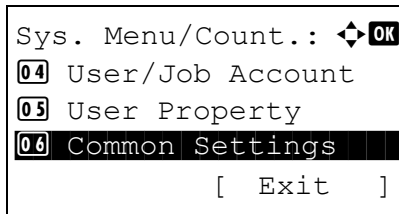

- 1 In the Sys. Menu/Count. menu, press the Δ or ∇ key to select [Common Settings].

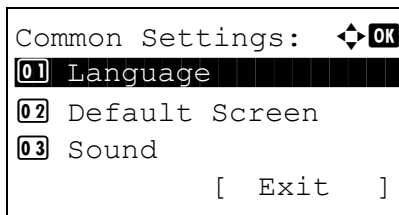

- 2 Press the **OK** key. The Common Settings menu appears.

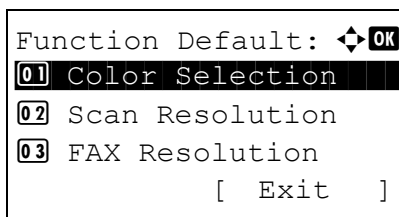

- 3 Press the Δ or ∇ key to select [Function Default].
- 4 Press the **OK** key. The Function Default menu appears.

- 5 Press the Δ or ∇ key to select [File Format].

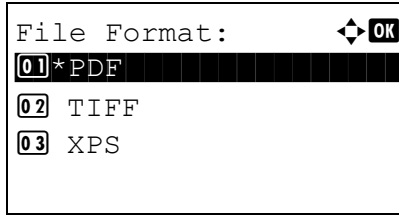

- 6 Press the **OK** key. File Format appears.
- 7 Press the Δ or ∇ key to select [PDF], [TIFF], [XPS] or [JPEG].
- 8 Press the **OK** key. *Completed.* is displayed and the screen returns to the Function Default menu.

Density

Set the default density. The available default settings are shown below.

Item	Description
Manual (Normal 0)	Set to (Normal 0) in the Manual density.
Auto	Set to Auto density.

Use the procedure below to select the default zoom setting.

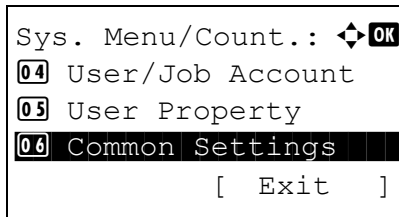

- 1 In the Sys. Menu/Count. menu, press the Δ or ∇ key to select [Common Settings].

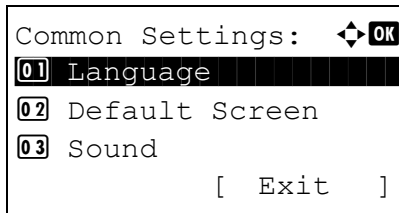

- 2 Press the **OK** key. The Common Settings menu appears.

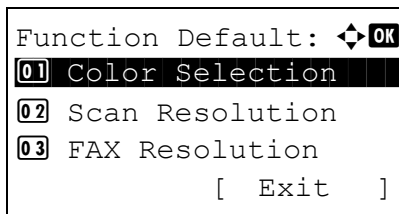

- 3 Press the Δ or ∇ key to select [Function Default].
- 4 Press the **OK** key. The Function Default menu appears.
- 5 Press the Δ or ∇ key to select [Density].

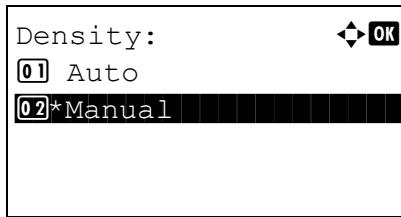

6 Press the **OK** key. Density appears.

7 Press the Δ or ∇ key to select [Auto] or [Manual].

8 Press the **OK** key. *Completed.* is displayed and the screen returns to the Function Default menu.

Zoom

Select the enlarged/reduced default when paper size/sending size changed after the originals set. The available default settings are shown below.

Item	Description
100%	Copy (send/save) at actual size (100%).
Auto	Automatically reduce or enlarge the originals to match paper size/ sending size.

Use the procedure below to select the default zoom setting.

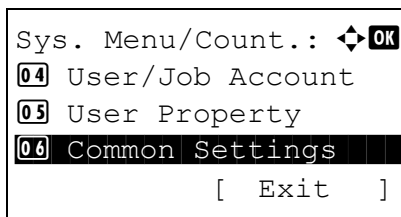

1 In the Sys. Menu/Count. menu, press the Δ or ∇ key to select [Common Settings].

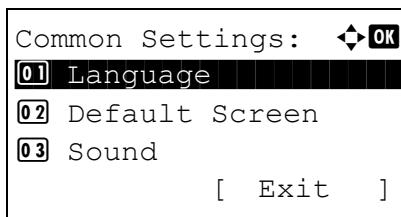

2 Press the **OK** key. The Common Settings menu appears.

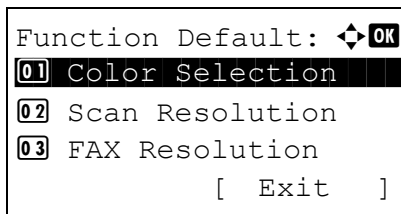

3 Press the Δ or ∇ key to select [Function Default].

4 Press the **OK** key. The Function Default menu appears.

5 Press the Δ or ∇ key to select [Zoom].

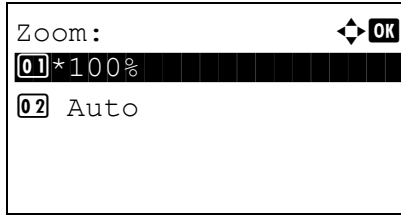

6 Press the **OK** key. Zoom appears.

7 Press the Δ or ∇ key to select [100%] or [Auto].

8 Press the **OK** key. *Completed.* is displayed and the screen returns to the Function Default menu.

File Name Entry

Set an automatically entered name (default) for jobs. Additional information such as Date and Time and Job No. can also be set.

The table below lists the additional information available.

Item	Description
None	No additional information available.
Date	Adds date and time.
Job No.	Adds the job number.
Job No. + Date	Adds the job number plus date and time.
Date + Job No.	Adds date and time plus the job number.

NOTE:

- Refer to *page 4-18* and *page 5-17* for name entry.
- Refer to *Character Entry Method on Appendix-5* for details on entering characters.

Use the procedure below to set the default file name.

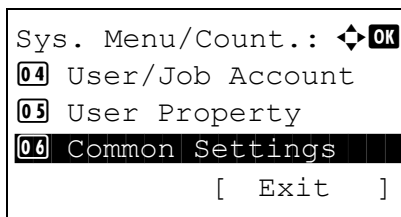

1 In the Sys. Menu/Count. menu, press the Δ or ∇ key to select [Common Settings].

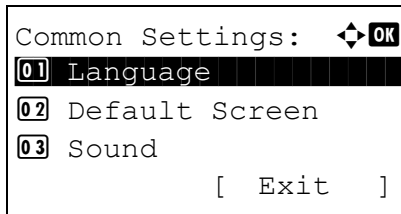

2 Press the **OK** key. The Common Settings menu appears.

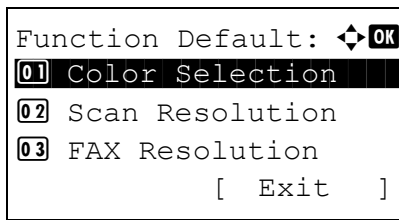

- 3 Press the Δ or ∇ key to select [Function Default].
- 4 Press the **OK** key. The Function Default menu appears.

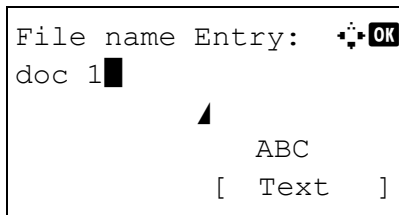

- 5 Press the Δ or ∇ key to select [File Name Entry].
- 6 Press the **OK** key. File Name Entry appears. Enter the document name (up to 32 characters).

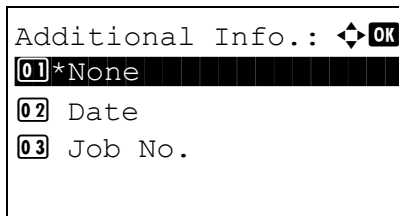

- 7 Press the **OK** key. Additional Info appears.
- 8 Press the Δ or ∇ key to select [None], [Date], [JobNo.], [JobNo. + Date] or [Date + JobNo.].
- 9 Press the **OK** key. *Completed.* is displayed and the screen returns to the Function Default menu.

Subject/Body

Set the subject and body automatically entered (default subject and body) when sending the scanned originals by E-mail.

NOTE:

- Refer to *Send as E-mail on page 3-21.*
 - Refer to *Character Entry Method on Appendix-5* for details on entering characters.
-

Use the procedure below to set the default e-mail subject and message body.

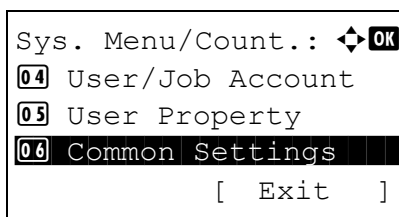

- 1 In the Sys. Menu/Count. menu, press the Δ or ∇ key to select [Common Settings].

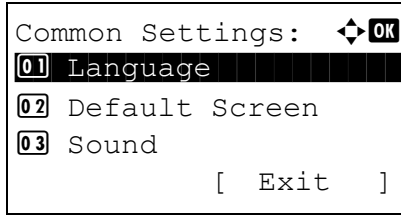

2 Press the **OK** key. The Common Settings menu appears.

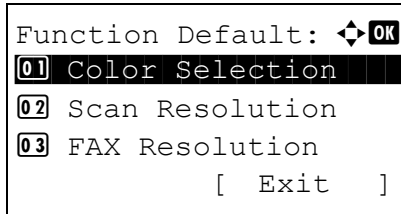

3 Press the Δ or ∇ key to select [Function Default].

4 Press the **OK** key. The Function Default menu appears.

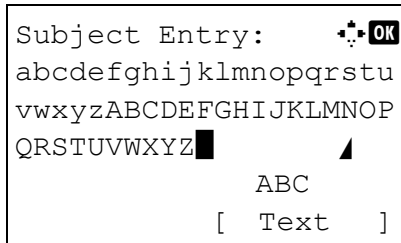

5 Press the Δ or ∇ key to select [Subject/Body].

6 Press the **OK** key. Subject Entry appears. Enter the e-mail subject (up to 60 characters).

If you press the Back key, you can return to the Function Default menu.

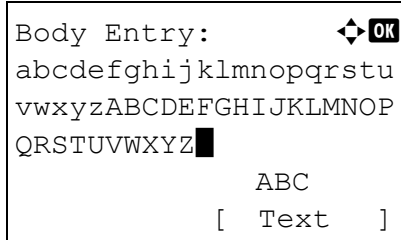

7 Press the **OK** key. Body Entry appears. Enter e-mail body text (up to 500 characters).

If you press the Back key, you can return to Subject Entry.

8 Press the **OK** key. *Completed.* is displayed and the screen returns to the Function Default menu.

Collate

Set the defaults for Collate. The table below shows the available settings.

Item		Description
Collate	Off	Collate not performed.
	On	Collate performed.

NOTE: Refer to page 3-17 for Collate/Offset.

Use the procedure below to set the default Collate/Offset settings.

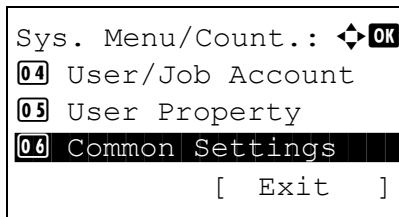

1 In the Sys. Menu/Count. menu, press the Δ or ∇ key to select [Common Settings].

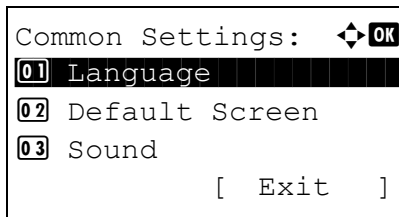

2 Press the **OK** key. The Common Settings menu appears.

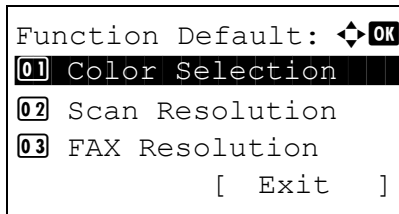

3 Press the Δ or ∇ key to select [Function Default].

4 Press the **OK** key. The Function Default menu appears.

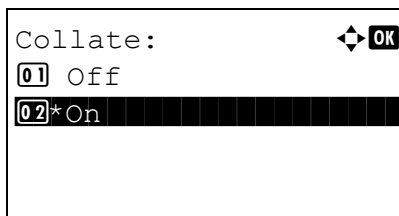

5 Press the Δ or ∇ key to select [Collate].

6 Press the **OK** key. Collate appears.

7 Press the Δ or ∇ key to select [Off] or [On].

- 8 Press the **OK** key. *Completed.* is displayed and the screen returns to the Function Default menu.

EcoPrint

Select the EcoPrint default. The table below shows the available settings.

Item	Description
Off	No EcoPrint performed.
On	EcoPrint performed.

NOTE: Refer to page 4-10 for EcoPrint.

Use the procedure below to set the default EcoPrint setting.

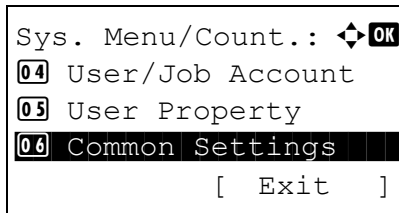

- 1 In the Sys. Menu/Count. menu, press the Δ or ∇ key to select [Common Settings].

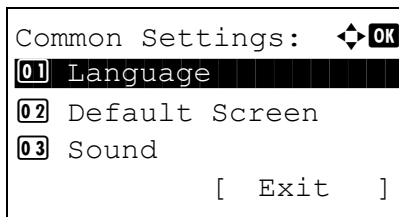

- 2 Press the **OK** key. The Common Settings menu appears.

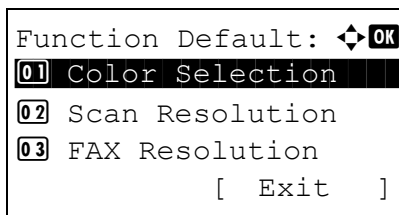

- 3 Press the Δ or ∇ key to select [Function Default].

- 4 Press the **OK** key. The Function Default menu appears.

- 5 Press the Δ or ∇ key to select [EcoPrint].

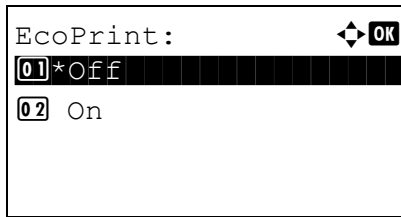

6 Press the **OK** key. EcoPrint appears.

7 Press the Δ or ∇ key to select [Off] or [On].

8 Press the **OK** key. *Completed.* is displayed and the screen returns to the Function Default menu.

2 in 1 Layout

Select the default value for layout when [2 in 1] is selected for Combine. Items available for the default value are as follows:

Item	Description
L to R T to B	Arranges from left to right or top to bottom.
R to L	Arranges from right to left.

Use the procedure below to select the default value for layout.

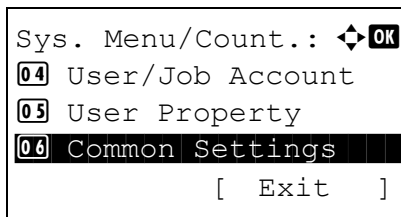

1 In the Sys. Menu/Count. menu, press the Δ or ∇ key to select [Common Settings].

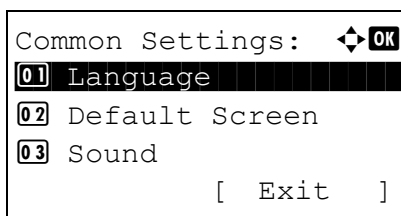

2 Press the **OK** key. The Common Settings menu appears.

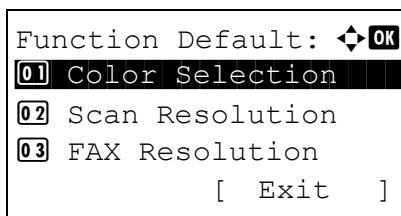

3 Press the Δ or ∇ key to select [Function Default].

4 Press the **OK** key. The Function Default menu appears.

5 Press the Δ or ∇ key to select [Detail Setting].

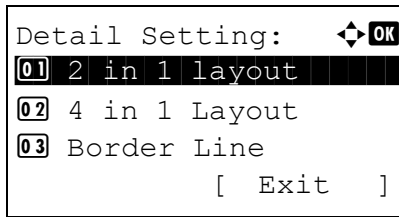

6 Press the **OK** key. The Detail Setting menu appears.

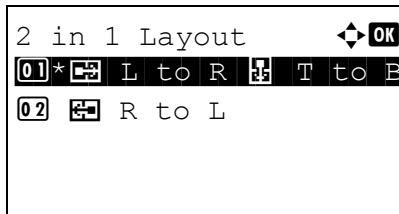

7 Press the Δ or ∇ key to select [2 in 1 Layout].

8 Press the **OK** key. 2 in 1 Layout appears.

9 Press the Δ or ∇ key to select [$\left[\begin{smallmatrix} \text{L} \\ \text{R} \end{smallmatrix} \right]$ L to R $\left[\begin{smallmatrix} \text{T} \\ \text{B} \end{smallmatrix} \right]$ T to B] or [$\left[\begin{smallmatrix} \text{R} \\ \text{L} \end{smallmatrix} \right]$ R to L].

10 Press the **OK** key. *Completed.* is displayed and the screen returns to the Detail Setting menu.

4 in 1 Layout

Select the default value for layout when [4 in 1] is selected for Combine. Items available for the default value are as follows:

Item	Description
$\left[\begin{smallmatrix} \text{R} \\ \text{D} \end{smallmatrix} \right]$ Right then Down	Arranges from upper left to right.
$\left[\begin{smallmatrix} \text{D} \\ \text{R} \end{smallmatrix} \right]$ Down then Right	Arranges from upper left to bottom.
$\left[\begin{smallmatrix} \text{L} \\ \text{D} \end{smallmatrix} \right]$ Left then Down	Arranges from upper right to left.
$\left[\begin{smallmatrix} \text{D} \\ \text{L} \end{smallmatrix} \right]$ Down then Left	Arranges from upper right to bottom.

Use the procedure below to select the default value for layout.

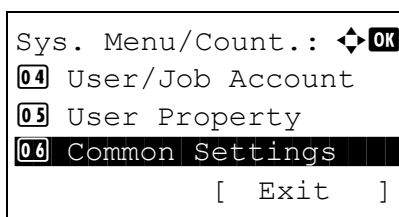

1 In the Sys. Menu/Count. menu, press the Δ or ∇ key to select [Common Settings].

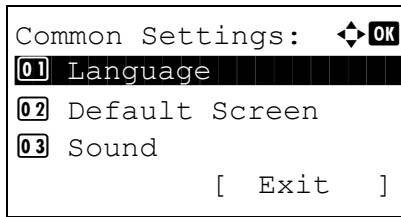

2 Press the **OK** key. The Common Settings menu appears.

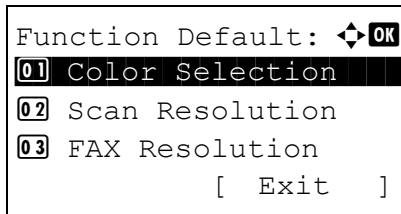

3 Press the Δ or ∇ key to select [Function Default].

4 Press the **OK** key. The Function Default menu appears.

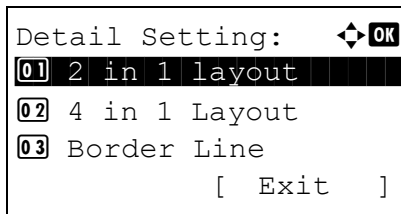

5 Press the Δ or ∇ key to select [Detail Setting].

6 Press the **OK** key. The Detail Setting menu appears.

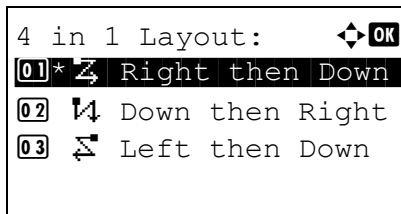

7 Press the Δ or ∇ key to select [4 in 1 Layout].

8 Press the **OK** key. 4 in 1 Layout appears.

9 Press the Δ or ∇ key to select [⤴ Right then Down], [⤵ Down then Right], [⤴ Left then Down] or [⤵ Down then Left].

10 Press the **OK** key. *Completed.* is displayed and the screen returns to the Detail Setting menu.

Border Line

Select the default value for border line when [2 in 1] is selected for Combine. Items available for the default value are as follows:

Item	Description
None	No border line.
Solid Line	Draws solid border lines.
⋮ Dotted Line	Draws dotted border lines.
‡ Positioning Mark	Puts a mark on the border line position.

Use the procedure below to select the default value for border line.

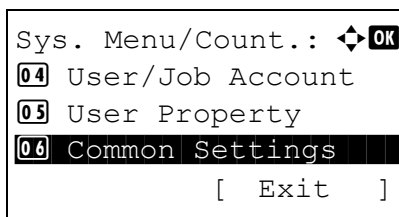

- 1 In the Sys. Menu/Count. menu, press the Δ or ∇ key to select [Common Settings].

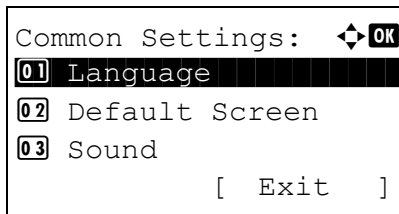

- 2 Press the **OK** key. The Common Settings menu appears.

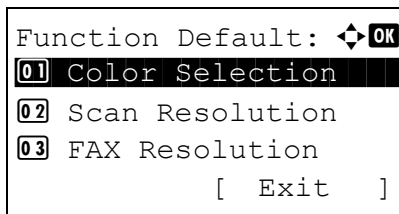

- 3 Press the Δ or ∇ key to select [Function Default].

- 4 Press the **OK** key. The Function Default menu appears.

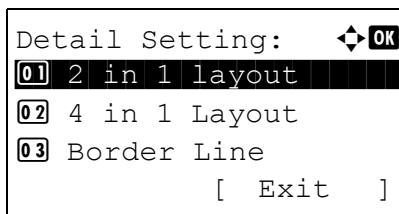

- 5 Press the Δ or ∇ key to select [Detail Setting].

- 6 Press the **OK** key. The Detail Setting menu appears.

- 7 Press the Δ or ∇ key to select [Border Line].

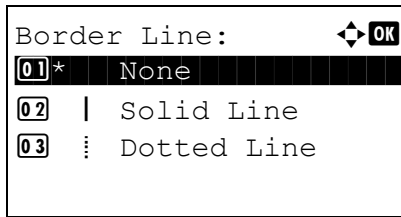

- 8 Press the **OK** key. Border Line appears.
- 9 Press the Δ or ∇ key to select [None], [| Solid Line], [: Dotted Line] or [+ Positioning Mark].
- 10 Press the **OK** key. *Completed.* is displayed and the screen returns to the Detail Setting menu.

Orig. Binding

Select the default value for the binding edge of the original when [2-sided>>1-sided] or [2-sided>>2-sided] is selected for Duplex. Items available for the default value are as follows:

NOTE: This setting is shown only when the optional document processor (DP-110) is installed.

Item	Description
Left/Right	Left/right binding
Top	Top binding

Use the procedure below to select the default value for the binding edge of the original.

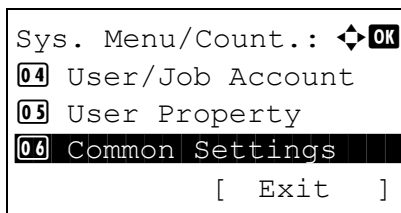

- 1 In the Sys. Menu/Count. menu, press the Δ or ∇ key to select [Common Settings].

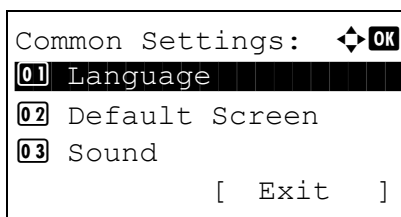

- 2 Press the **OK** key. The Common Settings menu appears.
- 3 Press the Δ or ∇ key to select [Function Default].

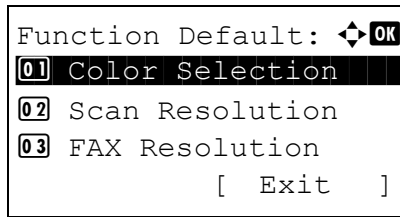

- 4 Press the **OK** key. The Function Default menu appears.

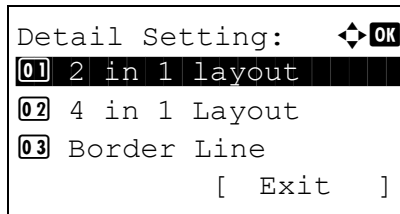

- 5 Press the Δ or ∇ key to select [Detail Setting].
- 6 Press the **OK** key. The Detail Setting menu appears.

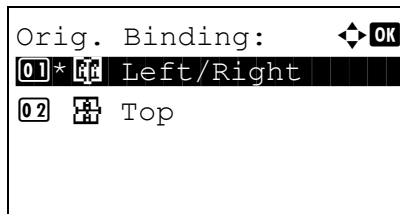

- 7 Press the Δ or ∇ key to select [Orig. Binding].
- 8 Press the **OK** key. Orig. Binding appears.

- 9 Press the Δ or ∇ key to select [**LR** Left/Right] or [**T** Top].
- 10 Press the **OK** key. *Completed.* is displayed and the screen returns to the Detail Setting menu.

Finish Binding

Select the default value for the binding edge of the finished copies when [1-sided>>2-sided] or [2-sided>>2-sided] is selected for Duplex. Items available for the default value are as follows:

Item	Description
 Left/Right	Left/right binding
 Top	Top binding

Use the procedure below to select the default value for the binding edge of the finished copies.

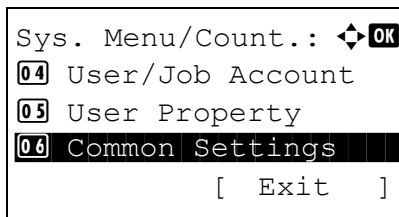

1 In the Sys. Menu/Count. menu, press the Δ or ∇ key to select [Common Settings].

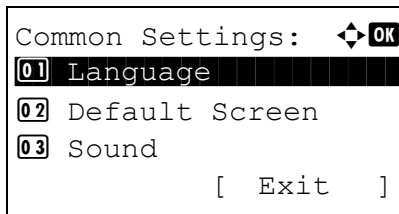

2 Press the **OK** key. The Common Settings menu appears.

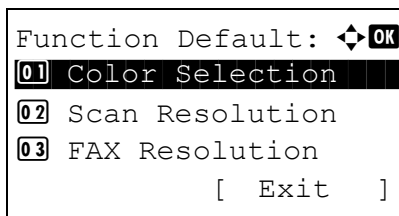

3 Press the Δ or ∇ key to select [Function Default].

4 Press the **OK** key. The Function Default menu appears.

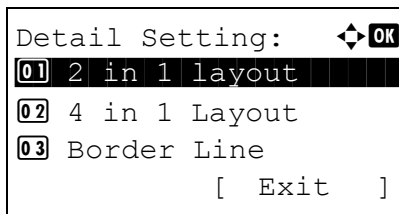

5 Press the Δ or ∇ key to select [Detail Setting].

6 Press the **OK** key. The Detail Setting menu appears.

7 Press the Δ or ∇ key to select [Finish Binding].

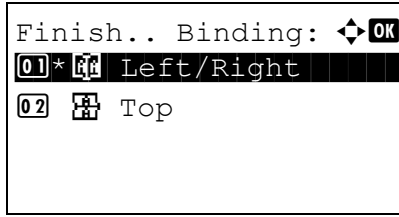

8 Press the **OK** key. Finish Binding appears.

9 Press the Δ or ∇ key to select [Left/Right] or [Top].

10 Press the **OK** key. *Completed.* is displayed and the screen returns to the Detail Setting menu.

Image Quality

Select the default value for image quality when File Format is selected. Select the default value in the range from [1 Low(High Comp)] (high compression) to [5 High(Low Comp)] (low compression).

Use the procedure below to select the default value for image quality.

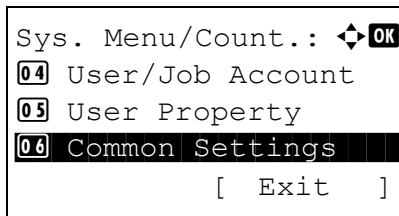

1 In the Sys. Menu/Count. menu, press the Δ or ∇ key to select [Common Settings].

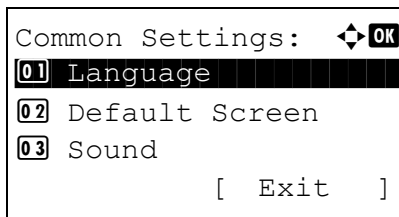

2 Press the **OK** key. The Common Settings menu appears.

3 Press the Δ or ∇ key to select [Function Default].

4 Press the **OK** key. The Function Default menu appears.

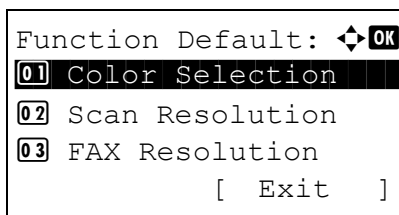

5 Press the Δ or ∇ key to select [Detail Setting].

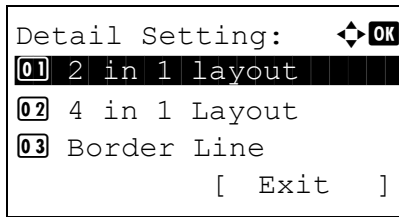

6 Press the **OK** key. The Detail Setting menu appears.

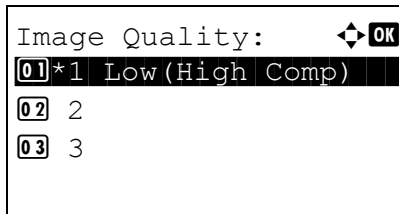

7 Press the Δ or ∇ key to select [Image Quality].

8 Press the **OK** key. Image Quality appears.

9 Press the Δ or ∇ key to select from [1 Low(High Comp)] to [5 High(Low Comp)].

10 Press the **OK** key. *Completed.* is displayed and the screen returns to the Detail Setting menu.

Color TIFF Comp.

Set the default value for compression method for TIFF images handled by this machine.

Use the procedure below to set the default value for color TIFF compression method.

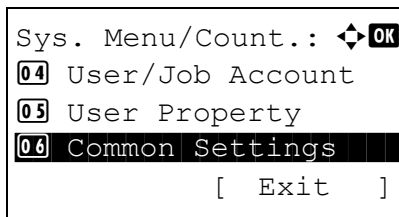

1 In the Sys. Menu/Count. menu, press the Δ or ∇ key to select [Common Settings].

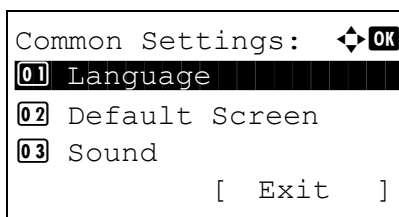

2 Press the **OK** key. The Common Settings menu appears.

3 Press the Δ or ∇ key to select [Function Default].

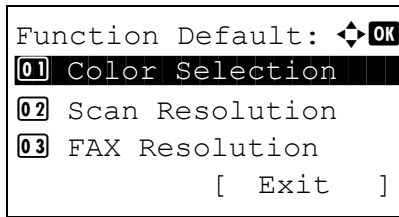

- 4 Press the **OK** key. The Function Default menu appears.

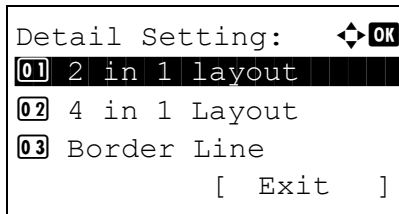

- 5 Press the Δ or ∇ key to select [Detail Setting].
- 6 Press the **OK** key. The Detail Setting menu appears.

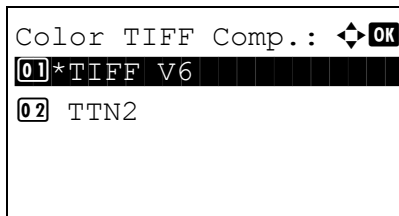

- 7 Press the Δ or ∇ key to select [Color TIFF Comp.].
- 8 Press the **OK** key. Color TIFF Comp. appears.

- 9 Press the Δ or ∇ key to select [TIFF V6] or [TTN2].
- 10 Press the **OK** key. *Completed.* is displayed and the screen returns to the Detail Setting menu.

XPS FitTo Page

Set the default value for XPS print range setting for printing an XPS document after enlarging or reducing it to the size that fits in the print area.

Use the procedure below to set the default value for XPS print range setting.

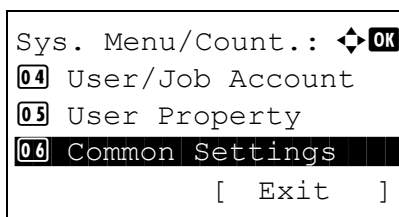

- 1 In the Sys. Menu/Count. menu, press the Δ or ∇ key to select [Common Settings].

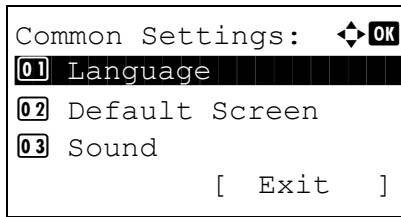

2 Press the **OK** key. The Common Settings menu appears.

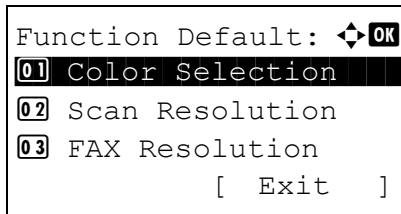

3 Press the Δ or ∇ key to select [Function Default].

4 Press the **OK** key. The Function Default menu appears.

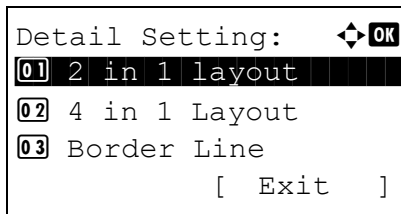

5 Press the Δ or ∇ key to select [Detail Setting].

6 Press the **OK** key. The Detail Setting menu appears.

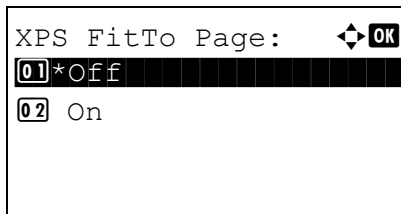

7 Press the Δ or ∇ key to select [XPS FitTo Page].

8 Press the **OK** key. XPS FitTo Page appears.

9 Press the Δ or ∇ key to select [On] or [Off].

10 Press the **OK** key. *Completed.* is displayed and the screen returns to the Detail Setting menu.

Login Operation

Specify the character entry method in the login screen that appears when user management is enabled.

Item	Description
Use Numeric Key	Use the numeric keys to select and enter characters.
Select Character	Enter characters by selecting them from the character palette that appears.

Use the procedure below to adjust the Login Operation.

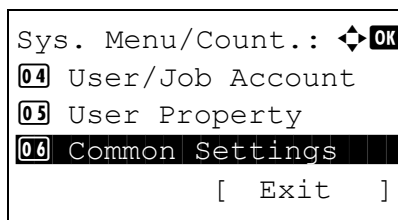

- 1 In the Sys. Menu/Count. menu, press the Δ or ∇ key to select [Common Settings].

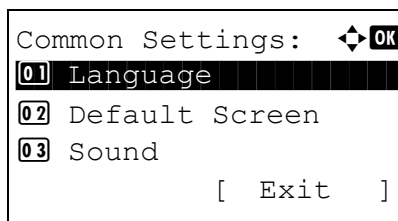

- 2 Press the **OK** key. The Common Settings menu appears.

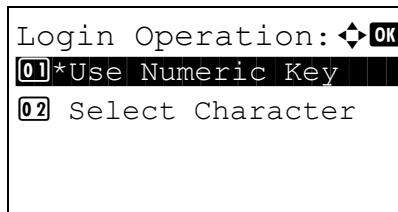

- 3 Press the Δ or ∇ key to select [Login Operation].
- 4 Press the **OK** key. Login Operation appears.

- 5 Press the Δ or ∇ key to select [Use Numeric Key] or [Select Character].
- 6 Press the **OK** key. *Completed.* is displayed and the screen returns to the Common Settings menu.

Copy Settings

The following settings are available for copying functions.

- Photo Processing ...8-56
- Paper Selection ...8-57
- Auto Paper Selection ...8-58
- Auto % Priority ...8-58
- Select Key Set ...8-60

NOTE: If user login administration is enabled, you can only change the settings by logging in with administrator privileges.

Photo Processing

Set the resolution for copying a photo.

Item	Description
Dithering(Normal)	Sets the resolution to standard.
Dithering(Rough)	Sets the resolution to low.

Use the procedure below to set Photo Processing.

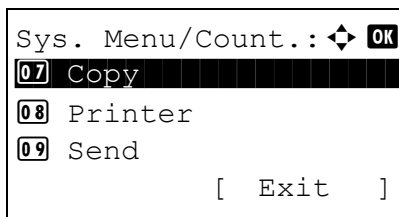

- 1 In the Sys. Menu/Count. menu, press the Δ or ∇ key to select [Copy].

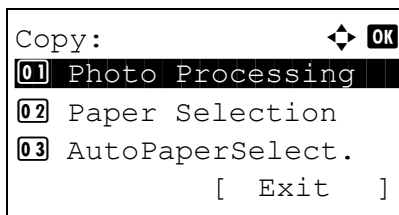

- 2 Press the **OK** key. The Copy menu appears.

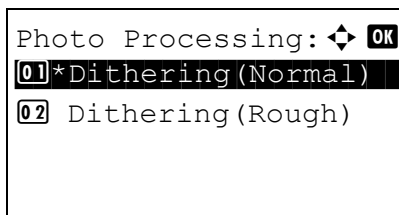

- 3 Press the Δ or ∇ key to select [Photo Processing].
- 4 Press the **OK** key. Photo Processing appears.

- 5 Press the Δ or ∇ key to select [Dithering(Normal)] or [Dithering(Rough)].
- 6 Press the **OK** key. *Completed.* is displayed and the screen returns to the Copy menu.

Paper Selection

Set the default paper selection. The table below shows the available settings.

Item	Description
Auto	Automatically select the cassette containing paper in the same size as originals.
Def. PaperSource	Select paper source set by Default Paper Source (refer to <i>page 8-22</i>).

Use the procedure below to set the default paper selection.

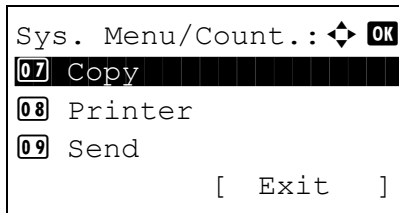

- 1 In the Sys. Menu/Count. menu, press the Δ or ∇ key to select [Copy].

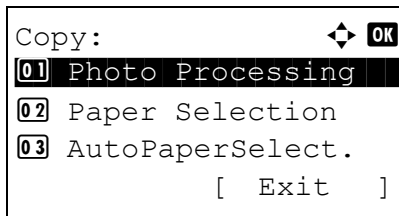

- 2 Press the **OK** key. The Copy menu appears.

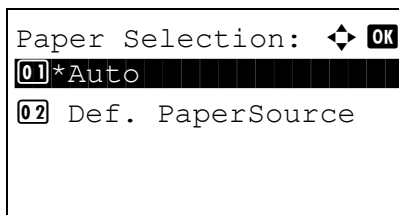

- 3 Press the Δ or ∇ key to select [Paper Selection].
- 4 Press the **OK** key. Paper Selection appears.

- 5 Press the Δ or ∇ key to select [Auto] or [Def. Paper Source].
- 6 Press the **OK** key. *Completed.* is displayed and the screen returns to the Copy menu.

Auto Paper Selection

If [Auto] is selected for Paper Selection, set the paper size selection method when the zoom changes. The table below shows the available settings.

Item	Description
MostSuitableSize	Select paper based on the current zoom and the size of the original.
Same as OrigSize	Select paper that matches the size of the original, regardless the zoom.

Use the procedure below to specify the action performed for Auto Paper Selection.

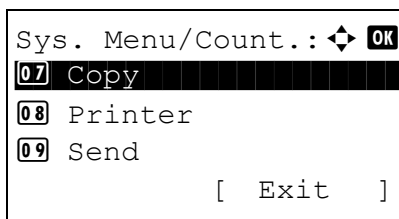

- 1 In the Sys. Menu/Count. menu, press the Δ or ∇ key to select [Copy].

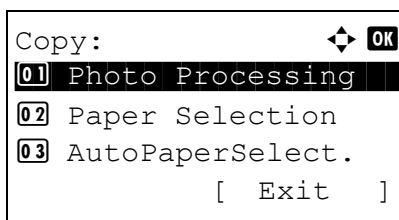

- 2 Press the OK key. The Copy menu appears.

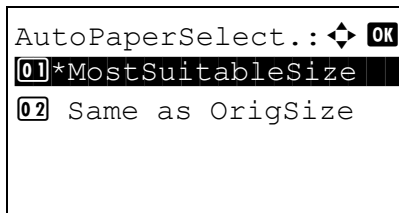

- 3 Press the Δ or ∇ key to select [AutoPaperSelect.].

- 4 Press the OK key. AutoPaperSelect. appears.

- 5 Press the Δ or ∇ key to select [MostSuitableSize] or [Same as OrigSize].

- 6 Press the OK key. *Completed.* is displayed and the screen returns to the Copy menu.

Auto % Priority

When a paper source of different size from the original is selected, select whether automatic zoom (reduce/zoom) is performed.

The table below shows the available settings. The default setting is *Off*.

Item	Detail
Off	No zoom performed (copied in original size).
On	Automatic zoom performed as appropriate.

Use the procedure below to specify the automatic zoom priority.

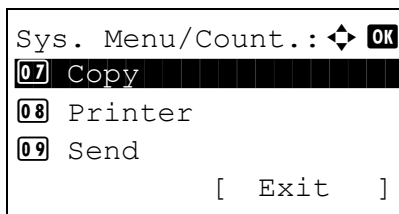

1 In the Sys. Menu/Count. menu, press the Δ or ∇ key to select [Copy].

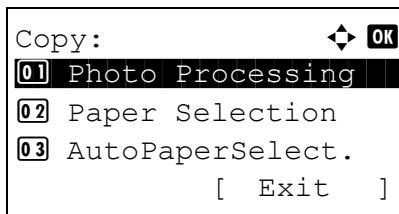

2 Press the OK key. The Copy menu appears.

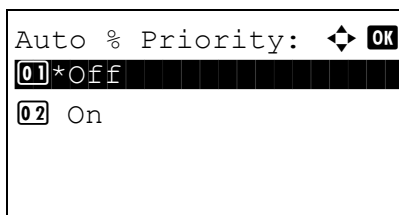

3 Press the Δ or ∇ key to select [Auto % Priority.].

4 Press the OK key. AutoPaperSelect. appears.

5 Press the Δ or ∇ key to select [Off] or [On].

6 Press the OK key. *Completed.* is displayed and the screen returns to the Copy menu.

Select Key Set

If you register a function to the **Left Select** key or **Right Select** key, you can quickly set the function when using copy functions.

You can register one of the following functions to each key.

- None
- Paper Selection
- Collate
- Duplex
- Zoom
- Combine
- Original Size
- Orig.Orientation
- Original Image
- Density
- EcoPrint
- Continuous Scan
- File Name Entry
- JobFinish Notice
- Print Override

Use the procedure below to set Select Key Set.

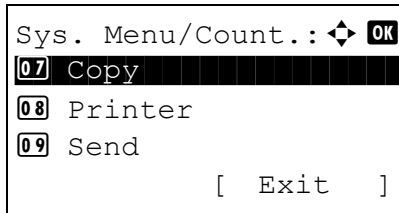

- 1 In the Sys. Menu/Count. menu, press the Δ or ∇ key to select [Copy].

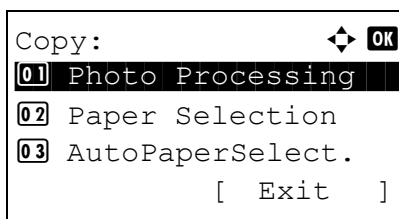

- 2 Press the **OK** key. The Copy menu appears.

- 3 Press the Δ or ∇ key to select [Select Key Set.].

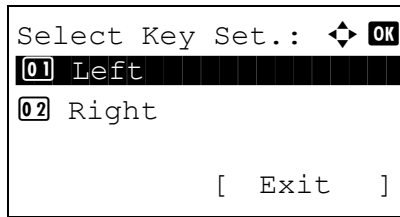

4 Press the **OK** key. Select Key Set. appears.

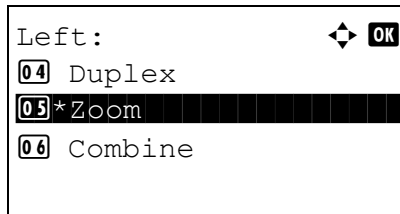

5 Press the Δ or ∇ key to select [Left] or [Right].

6 Press the **OK** key. This displays the function selection screen for the flexible key selected in step 5. The screen shown is the one when [Left] is selected.

7 Press the Δ or ∇ key to select the function you want to register to the flexible key.

8 Press the **OK** key. *Completed.* is displayed and the screen returns to the Copy menu.

This function is
already registered.

IMPORTANT: If you try to set the function that is registered to the other flexible key, you cannot set it and *This function is already registered.* is displayed.

Sending Settings

The sending settings allow you to specify the following sending function options.

- Select Key Set ...8-62
- DestinationCheck ...8-64

NOTE: If user login administration is enabled, you can only change the settings by logging in with administrator privileges.

Select Key Set

If you register a function to the **Left Select** key or **Right Select** key, you can quickly set the function when using sending functions.

You can register one of the following functions to each key.

- None
- Color Selection
- Original Size
- Original Image
- Scan Resolution
- Sending Size
- Zoom
- Orig.Orientation
- Continuous Scan
- File Format
- File Name Entry
- Subject/Body
- JobFinish Notice
- FAX Resolution
- FAX Direct TX
- FAX Delayed TX
- FAX RX Polling
- Density
- Duplex
- FTP Encrypted TX

Use the procedure below to set Select Key Set.

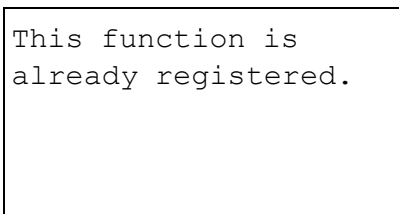
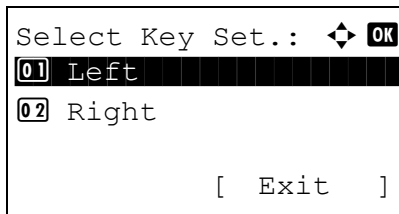
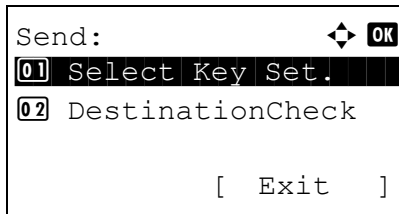
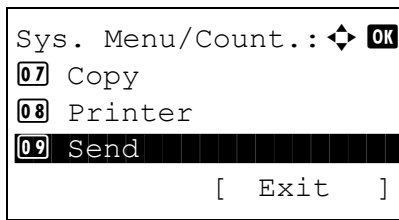

- 1 In the Sys. Menu/Count. menu, press the Δ or ∇ key to select [Send].
- 2 Press the **OK** key. The Send menu appears.
- 3 Press the Δ or ∇ key to select [Select Key Set.].
- 4 Press the **OK** key. Select Key Set. appears.
- 5 Press the Δ or ∇ key to select [Left] or [Right].
- 6 Press the **OK** key. This displays the function selection screen for the flexible key selected in step 5. The screen shown is the one when [Left] is selected.
- 7 Press the Δ or ∇ key to select the function you want to register to the flexible key.
- 8 Press the **OK** key. *Completed.* is displayed and the screen returns to the Send menu.

IMPORTANT: If you try to set the function that is registered to the other flexible key, you cannot set it and *This function is already registered.* is displayed.

DestinationCheck

Set whether or not to display the destination confirmation screen before transmission. The setting items are as follows:

Item	Description
Dest. Confirm.	Sets whether or not to display the destination confirmation screen before transmission.
Check New Dest.	Sets whether or not to display the destination confirmation screen for a new destination.

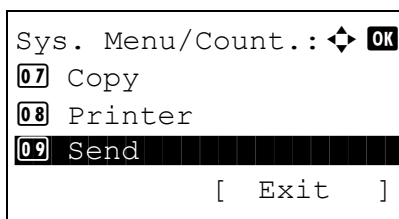

1 In the Sys. Menu/Count. menu, press the Δ or ∇ key to select [Send].

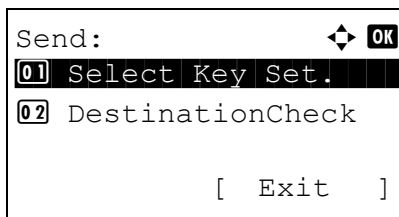

2 Press the **OK** key. The Send menu appears.

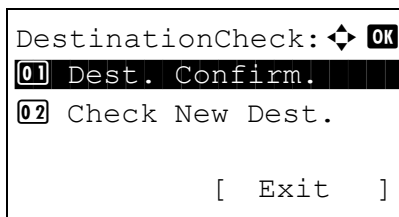

3 Press the Δ or ∇ key to select [DestinationCheck].

4 Press the **OK** key. The DestinationCheck menu appears.

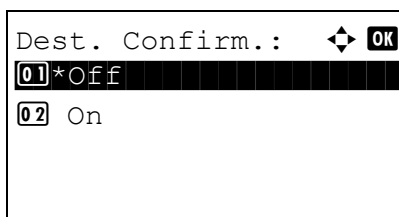

5 Press the Δ or ∇ key to select [Dest. Confirm.] or [Check New Dest.].

6 Press the **OK** key. This displays the setting screen for the selected function.

The screen shown is the one when Dest. Confirm is selected.

- 7 Press the Δ or ∇ key to select [Off] or [On].
- 8 Press the **OK** key. *Completed.* is displayed and the screen returns to the Send menu.

Document Box Settings

The following settings are available for Document Box.

- Select Key Set ...8-66

Select Key Set

If you register a function to the **Left Select** key or **Right Select** key, you can quickly set the function when printing from or saving to a document box.

You can register one of the following functions to each key for either of printing from and saving to a document box.

Print

- None
- Collate
- Paper Selection
- Duplex
- File Name Entry
- JobFinish Notice
- Print Override
- Encrypted PDF

Store

- None
- Color Selection
- Original Size
- Original Image
- Scan Resolution
- Storing Size
- Zoom
- Orig.Orientation
- Continuous Scan
- File Format
- File Name Entry
- JobFinish Notice
- Density
- Duplex

Use the procedure below to set Select Key Set.

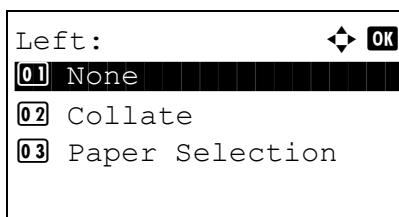
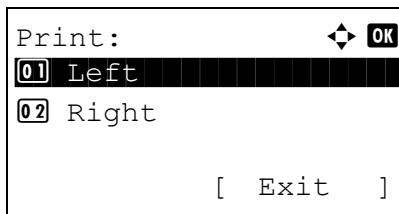
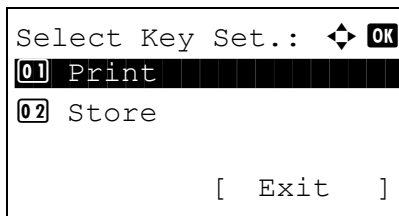
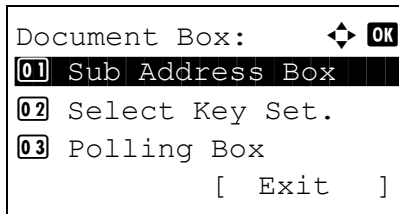
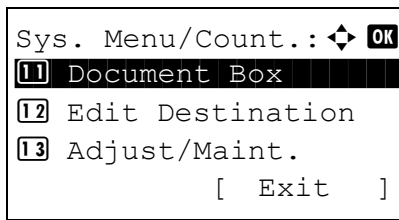

- 1 In the Sys. Menu/Count. menu, press the Δ or ∇ key to select [Document Box].
- 2 Press the **OK** key. The Document Box menu appears.
- 3 Press the Δ or ∇ key to select [Select Key Set.].
- 4 Press the **OK** key. Select Key Set. appears.
- 5 Press the Δ or ∇ key to select [Print] or [Store].
- 6 Press the **OK** key. This displays the flexible key selection screen for the function selected in step 5. The screen shown is the one when [Print] is selected.
- 7 Press the Δ or ∇ key to select [Left] or [Right].
- 8 Press the **OK** key. This displays the function selection screen for the flexible key selected in step 7. The screen shown is the one when [Left] is selected.
- 9 Press the Δ or ∇ key to select the function you want to register to the flexible key.
- 10 Press the **OK** key. *Completed.* is displayed and the screen returns to the Document Box menu.

This function is
already registered.

IMPORTANT: If you try to set the function that is registered to the other flexible key, you cannot set it and *This function is already registered.* is displayed.

Printer Settings

Printing from computers, settings are generally made on the application software screen. However, the following settings are available for configuring the defaults to customize the machine.

- Emulation Set ...8-69
- EcoPrint ...8-72
- Override A4/LTR ...8-73
- Duplex ...8-74
- Copies ...8-75
- Orientation ...8-76
- FormFeed Timeout ...8-77
- LF Action ...8-77
- CR Action ...8-78
- Paper Feed Mode...8-79

NOTE: If user login administration is enabled, you can only change the settings by logging in with administrator privileges.

Emulation Set

Select the emulation for operating this machine by commands oriented to other types of printers.

Selection of emulation

This machine can emulate the following printers:

- Line Printer
- IBM Proprinter
- DIABLO 630
- EPSON LQ-850
- PCL6
- KPDL
- KPDL(Auto)

Use the procedure below to select the emulation.

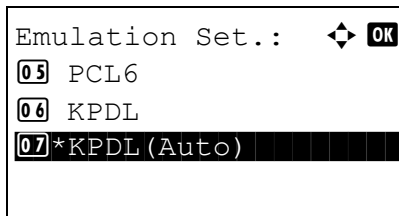
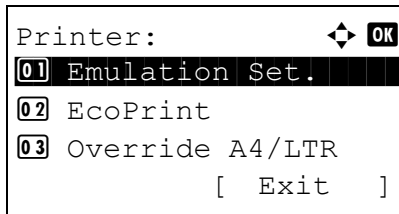
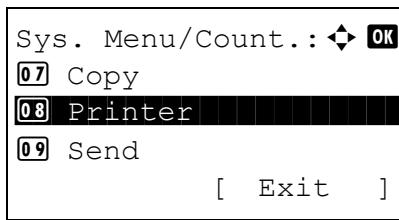

- 1 In the Sys. Menu/Count. menu, press the Δ or ∇ key to select [Printer].
- 2 Press the **OK** key. The Printer menu appears.
- 3 Press the Δ or ∇ key to select [Emuration Set.].
- 4 Press the **OK** key. Emuration Set. appears.
- 5 Press the Δ or ∇ key to select the printer you want to emulate.
- 6 Press the **OK** key. *Completed.* is displayed and the screen returns to the Printer menu.

NOTE: If you select [KPDL] or [KPDL(Auto)], the operation after selecting the emulation is different from others.

If you select [KPDL], refer to *page 8-71*.
If you select [KPDL(Auto)], refer to *page 8-71*.

When KPDL Is Selected for Emulation

When you use the KPDL emulation mode, set whether or not to output KPDL error reports. The default setting is *Off*.

Use the procedure below to make the setting.

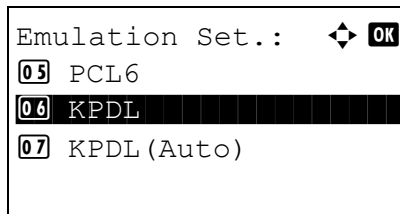

1 In Emulation Set, press the Δ or ∇ key to select [KPDL].

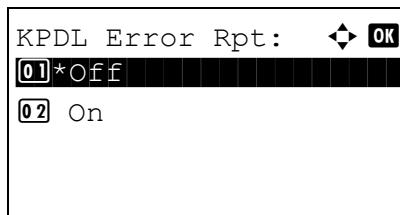

2 Press the **OK** key. KPDL Error Rpt appears.

3 Press the Δ or ∇ key to select [Off] or [On].

4 Press the **OK** key. *Completed.* is displayed and the screen returns to the Printer menu.

8

When KPDL(Auto) Is Selected for Emulation

If you use the KPDL(Auto) emulation mode, KPDL and another emulation mode can be automatically switched according to the data (alternative emulation).

For alternative emulation, you can select one of the following printers. The default setting is *PCL6*.

- Line Printer
- IBM Proprinter
- DIABLO 630
- EPSON LQ-850
- PCL6

Also, as when you select [KPDL], set whether or not to output KPDL error reports. The default setting is *Off*.

Use the procedure below to make the setting.

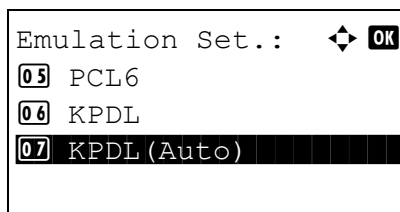

1 In Emulation Set, press the Δ or ∇ key to select [KPDL(Auto)].

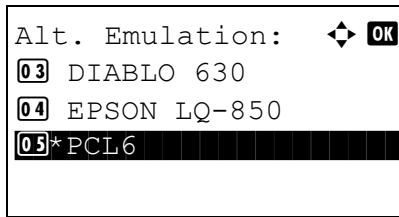

2 Press the **OK** key. Alt. Emulation appears.

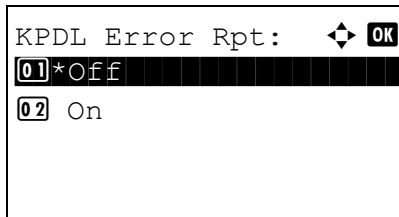

3 Press the Δ or ∇ key to select the printer for alternative emulation.

4 Press the **OK** key. KPDL Error Rpt appears.

5 Press the Δ or ∇ key to select [Off] or [On].

6 Press the **OK** key. *Completed.* is displayed and the screen returns to the Printer menu.

EcoPrint

EcoPrint conserves toner when printing. This is recommended for test copies where faded printing is not a problem.

Use the procedure below to specify the EcoPrint setting.

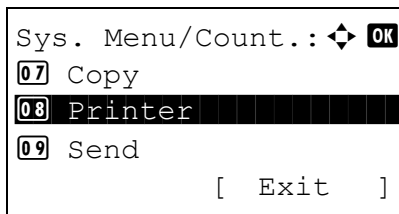

1 In the Sys. Menu/Count. menu, press the Δ or ∇ key to select [Printer].

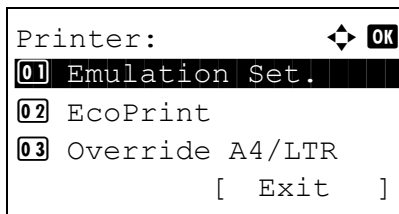

2 Press the **OK** key. The Printer menu appears.

3 Press the Δ or ∇ key to select [EcoPrint].

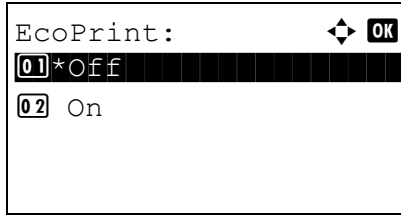

- 4 Press the **OK** key. EcoPrint appears.
- 5 Press the Δ or ∇ key to select [Off] or [On].
- 6 Press the **OK** key. *Completed.* is displayed and the screen returns to the Printer menu.

Override A4/LTR

Select whether to treat A4 size and Letter, which are similar in size, as the same size when printing. The table below shows the available settings.

Item	Description
On	A4 and Letter are regarded as the same in size. The machine will use whichever size is in the paper source.
Off	A4 and Letter are not regarded as the same in size.

Use the procedure below to specify the override A4/Letter setting. The default setting is *On*.

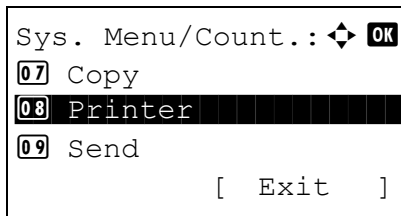

- 1 In the Sys. Menu/Count. menu, press the Δ or ∇ key to select [Printer].

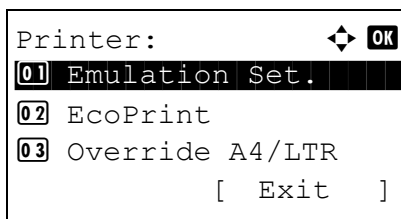

- 2 Press the **OK** key. The Printer menu appears.
- 3 Press the Δ or ∇ key to select [Override A4/LTR].

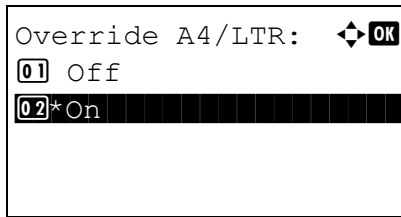

4 Press the **OK** key. Override A4/LTR appears.

5 Press the Δ or ∇ key to select [Off] or [On].

6 Press the **OK** key. *Completed.* is displayed and the screen returns to the Printer menu.

Duplex

Select binding orientation for duplex mode. The table below shows the available settings.

Item	Description	Finish
Off	No duplex mode	
Bind Long Edge	Longer edge bound	
Bind Short Edge	Shorter edge bound	

Use the procedure below to select a duplex setting.

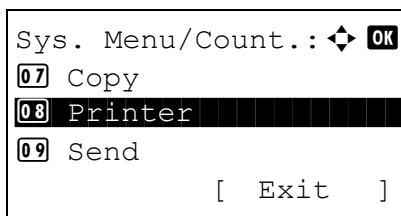

1 In the Sys. Menu/Count. menu, press the Δ or ∇ key to select [Printer].

2 Press the **OK** key. The Printer menu appears.

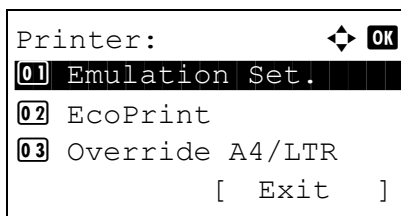

3 Press the Δ or ∇ key to select [Duplex].

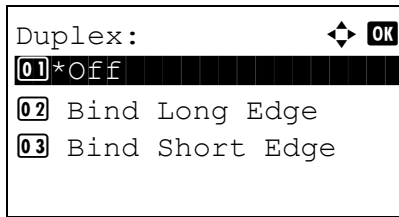

- 4 Press the **OK** key. Duplex appears.
- 5 Press the Δ or ∇ key to select [Off], [Bind Long Edge] or [Bind Short Edge].
- 6 Press the **OK** key. *Completed.* is displayed and the screen returns to the Printer menu.

Copies

Set the default number of copies, from 1 to 999.

Use the procedure below to specify the default number of copies.

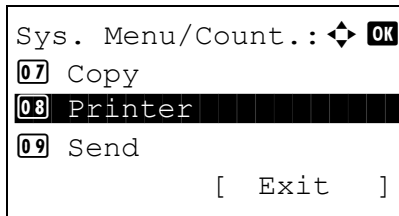

- 1 In the Sys. Menu/Count. menu, press the Δ or ∇ key to select [Printer].

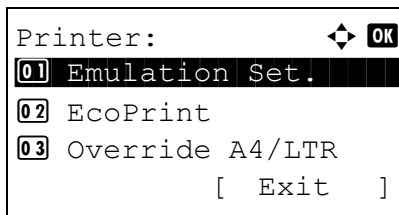

- 2 Press the **OK** key. The Printer menu appears.

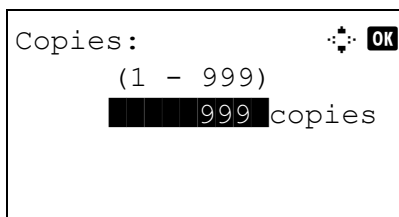

- 3 Press the Δ or ∇ key to select [Copies].
- 4 Press the **OK** key. Copies appears.
- 5 Press the Δ or ∇ key or the numeric keys to set the default number of copies.
- 6 Press the **OK** key. *Completed.* is displayed and the screen returns to the Printer menu.

Orientation

Set the default orientation, *Portrait* or *Landscape*.

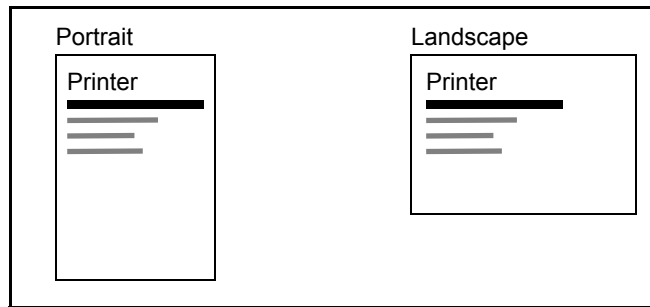

Use the procedure below to set the default orientation for printing.

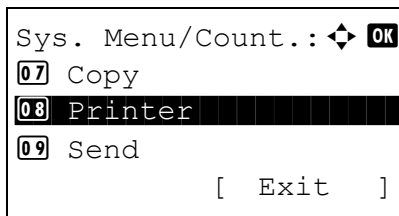

- 1 In the Sys. Menu/Count. menu, press the Δ or ∇ key to select [Printer].

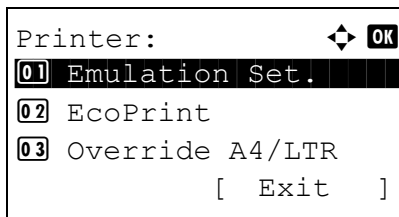

- 2 Press the **OK** key. The Printer menu appears.

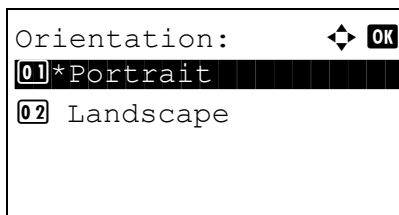

- 3 Press the Δ or ∇ key to select [Orientation].

- 4 Press the **OK** key. Orientation appears.

- 5 Press the Δ or ∇ key to select [Portrait] or [Landscape].

- 6 Press the **OK** key. *Completed.* is displayed and the screen returns to the Printer menu.

FormFeed Timeout

Receiving print data from the computer, the machine may sometimes wait if there is no information signalling that the last page does not have any more data to be printed. When the preset timeout passes, the machine automatically prints paper. The options are between 5 and 495 seconds.

Use the procedure below to set the form feed timeout.

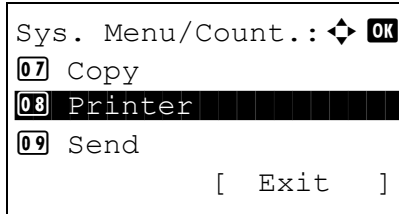

1 In the Sys. Menu/Count. menu, press the Δ or ∇ key to select [Printer].

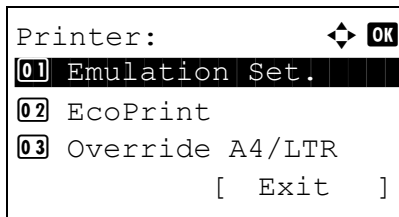

2 Press the **OK** key. The Printer menu appears.

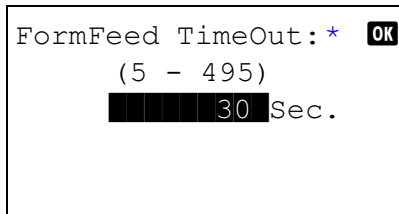

3 Press the Δ or ∇ key to select [FormFeed Timeout].

4 Press the **OK** key. FormFeed Timeout appears.

5 Press the Δ or ∇ key to set the Form Feed Timeout. You can set the timeout delay in seconds. You cannot use the numeric keys to enter this value.

6 Press the **OK** key. *Completed.* is displayed and the screen returns to the Printer menu.

LF Action

Set the line feed action when the machine receives the line feed code (character code 0AH). The table below shows the available settings. The default setting is *LF Only*.

Item	Description
LF Only	Only line feed performed.
LF and CR	Line feed and character return performed.

Item	Description
Ignore LF	No line feed performed.

Use the procedure below to specify a LF action.

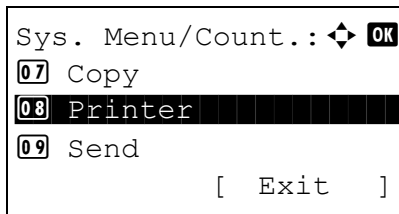

1 In the Sys. Menu/Count. menu, press the Δ or ∇ key to select [Printer].

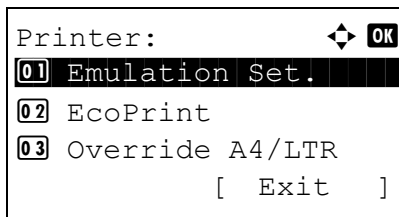

2 Press the **OK** key. The Printer menu appears.

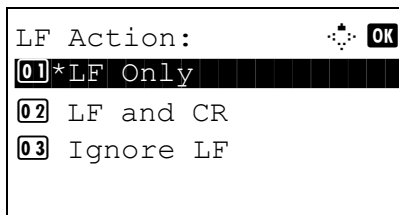

3 Press the Δ or ∇ key to select [LF Action].

4 Press the **OK** key. LF Action appears.

5 Press the Δ or ∇ key to select [LF Only], [LF and CR] or [Ignore LF].

6 Press the **OK** key. *Completed.* is displayed and the screen returns to the Printer menu.

CR Action

Set the character return action when the machine receives the character return code (character code 0DH). The table below shows the available settings. The default setting is *CR Only*.

Item	Description
CR Only	Only character return performed.
LF and CR	Character return and line feed performed.
Ignore CR	No character return performed.

Use the procedure below to specify a CR action.

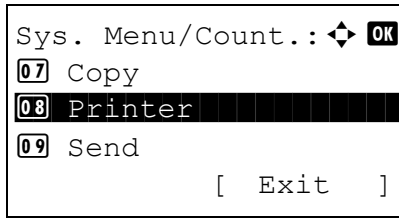

1 In the Sys. Menu/Count. menu, press the Δ or ∇ key to select [Printer].

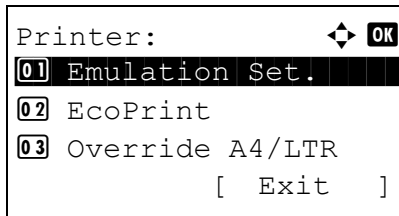

2 Press the **OK** key. The Printer menu appears.

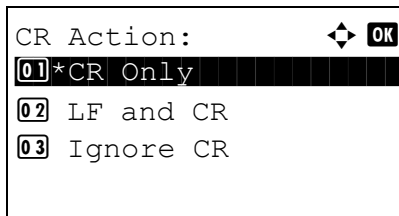

3 Press the Δ or ∇ key to select [CR Action].

4 Press the **OK** key.

5 Press the Δ or ∇ key to select [CR Only], [LF and CR] or [Ignore CR].

6 Press the **OK** key. *Completed.* is displayed and the screen returns to the Printer menu.

Paper Feed Mode

Set the default value of the paper feed direction used for the printer functions. The default setting is *Auto*.

Item	Description
Auto	Sets the paper feed direction automatically.
Fixed	Sets the paper feed direction the same as in the previous printing operation.

Use the procedure below to set Paper Feed Mode.

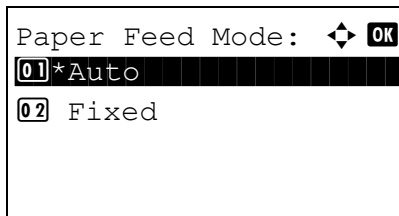
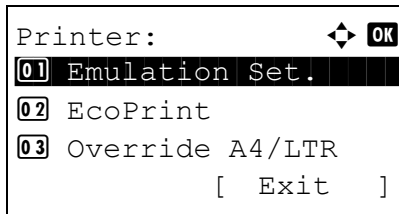
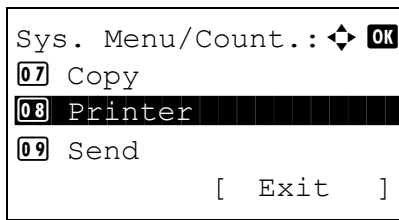

- 1** In the Sys. Menu/Count. menu, press the Δ or ∇ key to select [Printer].
- 2** Press the **OK** key. The Printer menu appears.
- 3** Press the Δ or ∇ key to select [Paper Feed Mode].
- 4** Press the **OK** key. Paper Feed Mode appears.
- 5** Press the Δ or ∇ key to select [Auto] or [Fixed].
- 6** Press the **OK** key. *Completed.* is displayed and the screen returns to the Printer menu.

Printing Reports/Sending Notice

Print reports to check the machine settings and status. Default settings for printing the result reports can also be configured.

NOTE: If user login administration is enabled, you can only print by logging in with administrator privileges.

Printing Reports

Printable reports are as follows.

Menu map

Outputs a menu map of this machine.



Status Page

Check the information including current settings, available memory space, and optional equipment installed.



Font List

Check the font samples installed in the machine.

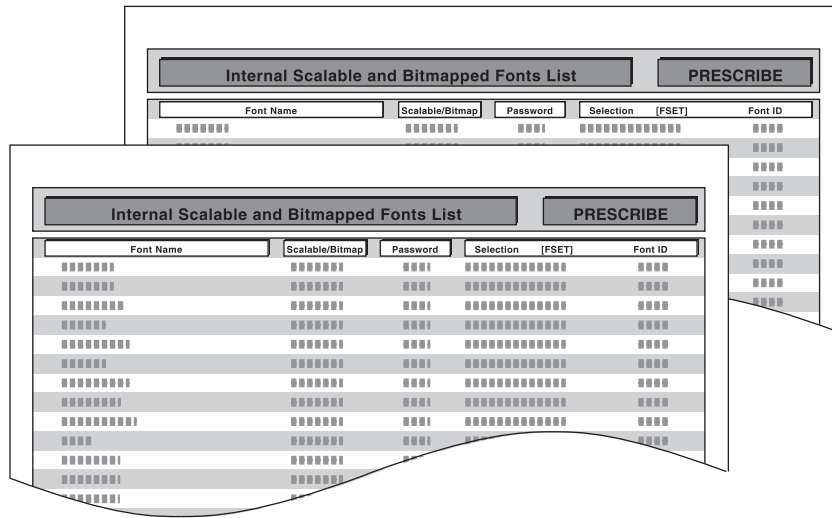

Use the procedure below to print a Menu Map / Status Page / Font List.

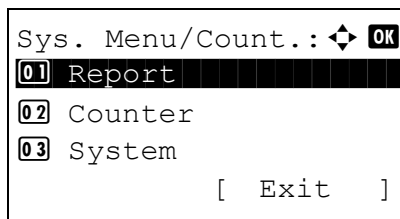

- 1 In the Sys. Menu/Count. menu, press the Δ or ∇ key to select [Report].

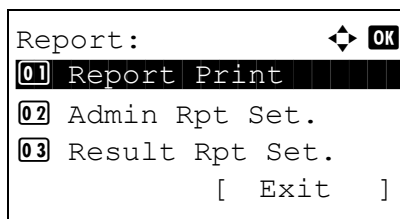

- 2 Press the **OK** key. The Report menu appears.

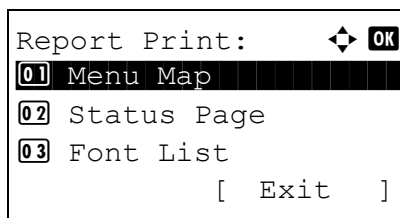

- 3 Press the Δ or ∇ key to select [Report Print].
- 4 Press the **OK** key. The Report Print menu appears.

- 5 Press the Δ or ∇ key to select [Menu Map], [Status Page] or [Font List].

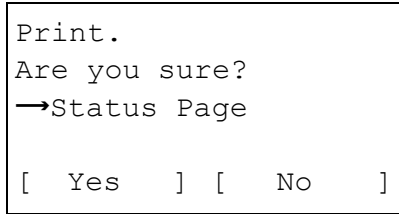

- 6 Press the **OK** key. A confirmation screen appears. The screen shown is the one when Status Page is selected.
- 7 Press [Yes] (the **Left Select** key). The selected report is output. *Accepted.* is displayed and the screen returns to the Report Print menu.

NOTE: When acceptance of jobs is prohibited, *Print, storing functions are restricted now.* is displayed and the output is canceled.

Service Status Page

More detailed information is available than on the Status Page. Service personnel usually print the service status pages for maintenance purpose.

Network Status Page

Check the information including network interface firmware version, network address and protocol.

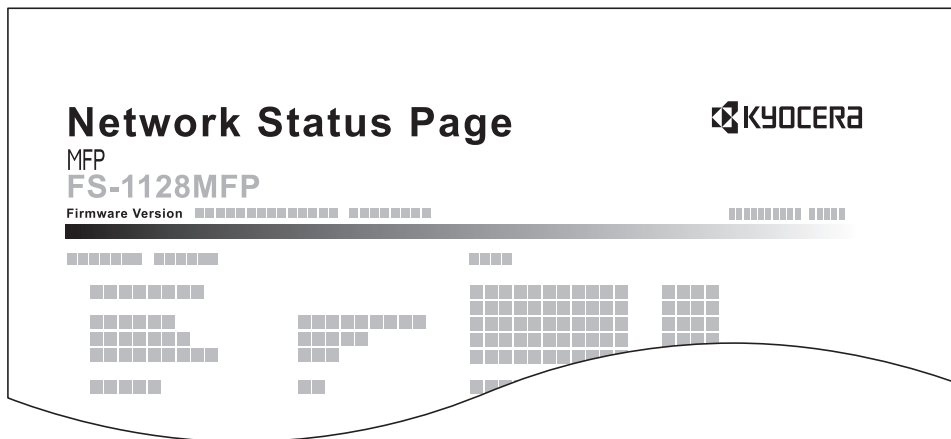

Use the procedure below to print a Service Status / Network Status.

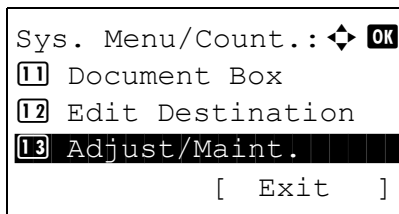

- 1 In the Sys. Menu/Count. menu, press the Δ or ∇ key to select [Adjust/Maint.].

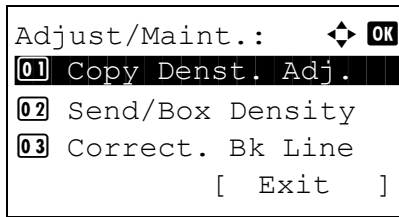

2 Press the **OK** key. The Adjust/Maint. menu appears.

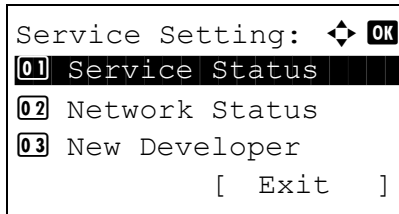

3 Press the Δ or ∇ key to select [Service Setting].

4 Press the **OK** key. Service Setting appears.

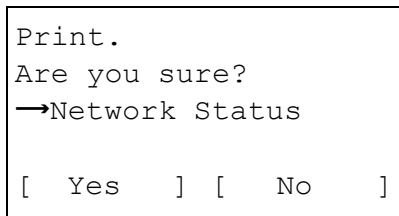

5 Press the Δ or ∇ key to select [Service Status] or [Network Status].

6 Press the **OK** key. A confirmation screen appears. The screen shown is the one when Network Status is selected.

7 Press [Yes] (the **Left Select** key). The selected report is output. *Accepted.* is displayed and the screen returns to the Adjust/Maint. menu.

NOTE: When acceptance of jobs is prohibited, *Print, storing functions are restricted now.* is displayed and the output is canceled.

Send Result Report

Automatically print a report of transmission result when a transmission is complete. The table below shows the available settings. The default setting is *Error Only*.

Item	Description
Off	No result report printed.
On	Result report automatically printed. Transmitted images can also be attached.
Error Only	Result report printed only when a transmission ends in an error. If two or more destinations are registered, the reports are printed only for the destinations with the errors. Transmitted images can also be attached.

Use the procedure below to send a Result Report.

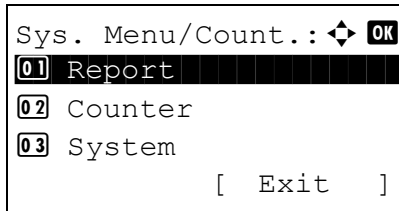

- 1 In the Sys. Menu/Count. menu, press the Δ or ∇ key to select [Report].

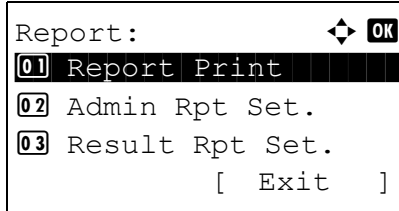

- 2 Press the **OK** key. The Report menu appears.

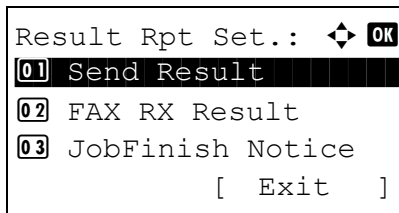

- 3 Press the Δ or ∇ key to select [Result Rpt Set.].
- 4 Press the **OK** key. The Result Rpt Set. menu appears.

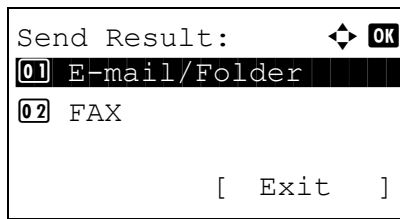

5 Press the Δ or ∇ key to select [Send Result]. The Send Result menu appears.

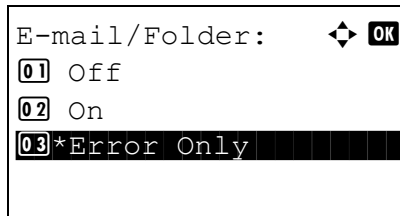

6 Press the Δ or ∇ key to select [E-mail/Folder]. E-mail/Folder appears.

7 Press the Δ or ∇ key to select [Off], [On] or [Error Only].

8 Press the **OK** key. A Result Report is sent. *Completed.* is displayed and the screen returns to the Send Result menu.

Adjustment/Maintenance

Adjust printing quality and conduct machine maintenance.

- Copy Denst. Adj. ...8-87
- Send/Box Density ...8-88
- Correct. Bk Line ...8-89
- New Developer...8-90

NOTE: If user login administration is enabled, you can only change the settings by logging in with administrator privileges.

Copy Denst. Adj.

Adjust copy density. Adjustment can be made in 7 levels both in auto and manual density modes.

Use the procedure below to adjust the copy density.

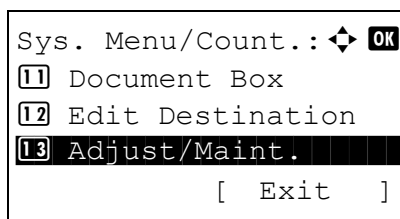

- 1 In the Sys. Menu/Count. menu, press the Δ or ∇ key to select [Adjust/Maint.].

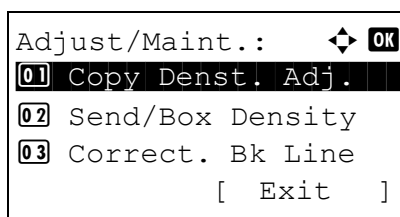

- 2 Press the **OK** key. The Adjust/Maint. menu appears.

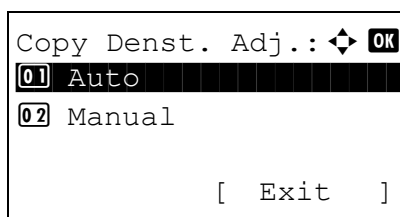

- 3 Press the Δ or ∇ key to select [Copy Denst. Adj.].
- 4 Press the **OK** key. Copy Denst. Adj. appears.

- 5 Press the Δ or ∇ key to select [Auto] or [Manual].

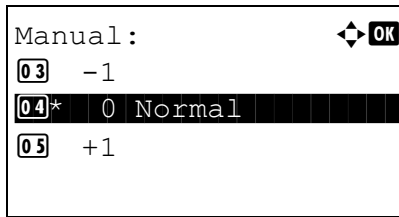

6 Press the **OK** key. This displays the density selection screen for the mode selected in step 5. The screen shown is the one when [Manual] is selected.

7 Press the Δ or ∇ key to select the density from [-3 Lighter] to [+3 Darker].

8 Press the **OK** key. *Completed.* is displayed and the screen returns to the Adjust/Maint. menu.

Send/Box Density

Adjust scan density when sending or storing the data in Document Box. Adjustment can be made in 7 levels both in auto and manual density modes.

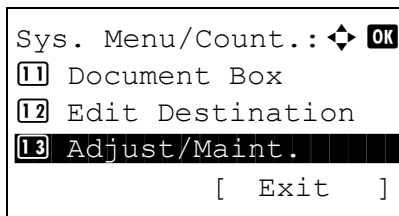

1 In the Sys. Menu/Count. menu, press the Δ or ∇ key to select [Adjust/Maint.].

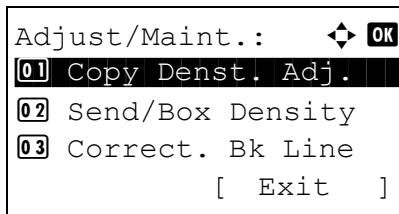

2 Press the **OK** key. The Adjust/Maint. menu appears.

3 Press the Δ or ∇ key to select [Send/Box Density].

4 Press the **OK** key. Send/Box Density appears.

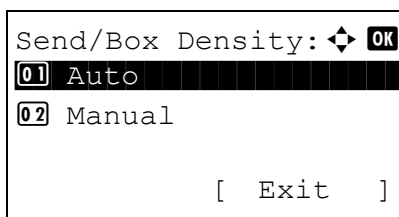

5 Press the Δ or ∇ key to select [Auto] or [Manual].

6 Press the **OK** key. This displays the density selection screen for the mode selected in step 5. The screen shown is the one when [Manual] is selected.

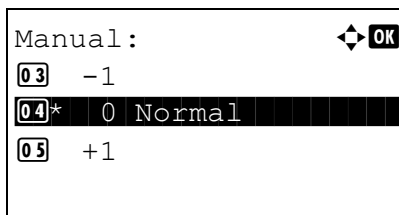

- 7 Press the Δ or ∇ key to select the density from [-3 Lighter] to [+3 Darker].
- 8 Press the **OK** key. *Completed.* is displayed and the screen returns to the Adjust/Maint. menu.

Correct. Bk Line

Correct fine black lines (black streaks caused by contamination), which may appear on the copies, when the optional document processor used.

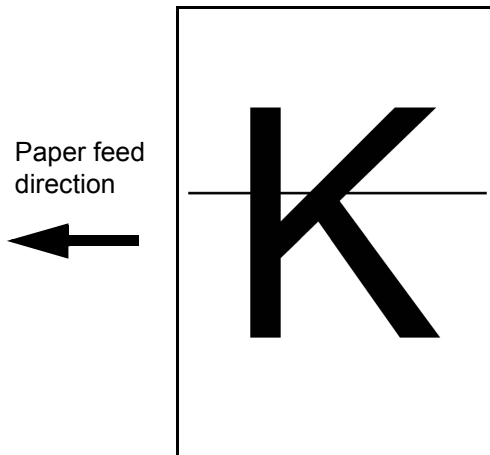

The table below shows the available settings.

Item	Description
Off	No correction performed.
On(Low)	Correction performed. The reproduction of the image becomes lower when using Off.
On(High)	Correction performed. Select this item if black streak remains after using On (Low). The reproduction of the image becomes lower when using On (Low).

NOTE: Using Correcting Fine Black Line can impair reproduction of fine characters. It is recommended to keep the default ([Off]).

Use the procedure below to specify the setting for correcting fine black lines.

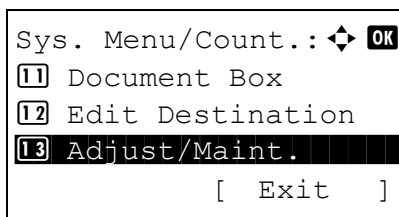

- 1 In the Sys. Menu/Count. menu, press the Δ or ∇ key to select [Adjust/Maint.].

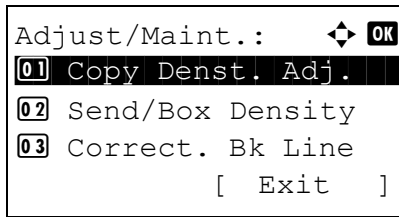

2 Press the **OK** key. The Adjust/Maint. menu appears.

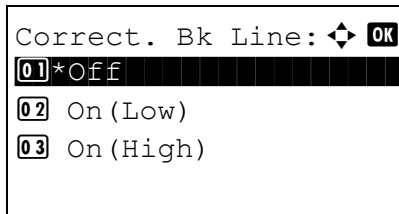

3 Press the Δ or ∇ key to select [Correct. Bk Line].

4 Press the **OK** key. Correct. Bk Line appears.

5 Press the Δ or ∇ key to select [Off], [On(Low)] or [On(High)].

6 Press the **OK** key. *Completed.* is displayed and the screen returns to the Adjust/Maint. menu.

New Developer

When the printing is too light or incomplete, even though there is enough toner, refresh the developer.

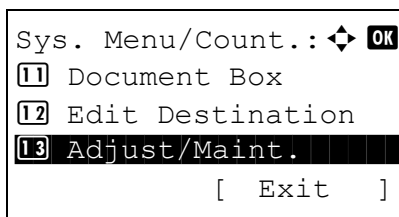

1 In the Sys. Menu/Count. menu, press the Δ or ∇ key to select [Adjust/Maint.].

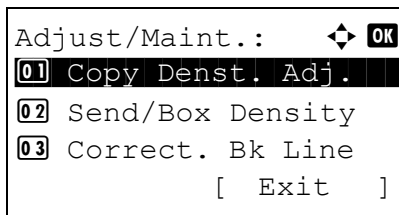

2 Press the **OK** key. The Adjust/Maint. menu appears.

3 Press the Δ or ∇ key to select [Service Setting].

4 Press the **OK** key. The Service Setting menu appears.

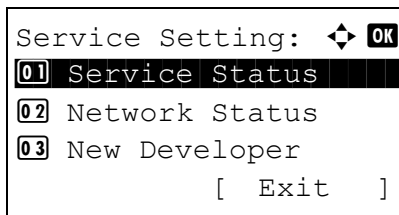

```
New Developer.  
Are you sure?  
  
[ Yes ] [ No ]
```

- 5 Press the Δ or ∇ key to select [New Developer].
- 6 Press the **OK** key. A confirmation screen appears.

- 7 Press [Yes] (the **Left Select** key). *Completed.* is displayed and the screen returns to the Adjust/Maint. menu.

Date/Timer

Date/Timer settings include:

- Date/Time ...8-92
- Date Format ...8-95
- Time Zone ...8-97
- Summer Time ...8-99
- Auto Error Clear ...8-101
- Auto Sleep ...8-103
- Auto Panel Reset ...8-106
- Low Power Timer ...8-108
- Unusable Time ...8-109

NOTE: If user login administration is enabled, you can only change the settings by logging in with administrator privileges.

Date/Time

Set the date and time for the location where you use the machine. If you perform Send as E-mail, the date and time set here will be displayed on the header.

CAUTION: Be sure to set Time Zone before the Date/Time setup.

Use the procedure below to set the date and time.

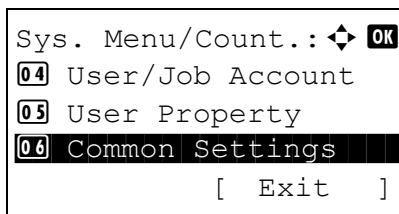

1 In the Sys. Menu/Count. menu, press the Δ or ∇ key to select [Common Settings].

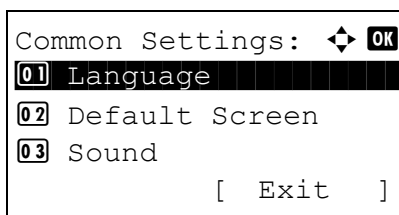

2 Press the **OK** key. The Common Settings menu appears.

3 Press the Δ or ∇ key to select [Date Setting], and press the **OK** key.

```

Login User Name:  [OK]
████████████████
Login Password:
[ Menu ] [ Login ]

```

```

Date Setting:  [OK]
[01] Date/Time
[02] Date Format
[03] Time Zone
           [ Exit ]

```

```

Date/Time:  [OK]
Year  Month  Day
2009      01   01
(Time Zone:Tokyo )

```

```

Date/Time:  [OK]
Hour  Min.  Second
███ 11 : 45 : 50
(Time Zone:Tokyo )

```

When you are performing user management and have not logged in, a login screen will appear. Then, enter the user ID and password to log in.

4 The Date Settings menu appears.

5 Press the Δ or ∇ key to select [Date/Time].

6 Press the **OK** key. The screen to enter the date of Date/Time appears.

7 Set the date.

Press the \triangleleft or \triangleright key to move to the item (Year / Month / Day) you want to enter.

Press the Δ or ∇ key to set each item.

8 Press the **OK** key. The screen to enter the time of Date/Time appears.

9 Set the time.

Press the \triangleleft or \triangleright key to move to the item (Hour / Min. / Second) you want to enter.

Press the Δ or ∇ key to set each item.

10 Press the **OK** key. *Completed.* is displayed and the screen returns to the Date Settings menu.

NOTE: If you try to change the date/time when a trial application (page 8-151) is running, the *If you change Date/Time setting, trial functions will be unavailable. Are you sure?* message is displayed. To change the date/time, press [Yes](the **Left Select** key).

Date Format

Select the display format of year, month, and date. The year is displayed in Western notation.

Use the procedure below to select the date format.

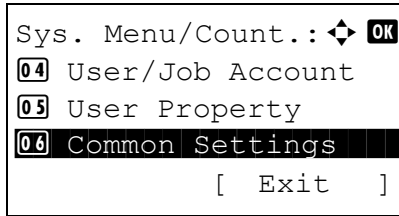

- 1 In the Sys. Menu/Count. menu, press the Δ or ∇ key to select [Common Settings].

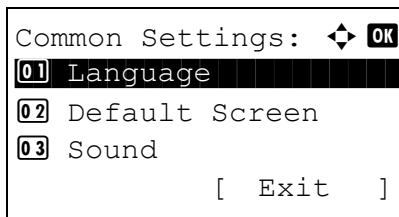

- 2 Press the **OK** key. The Common Settings menu appears.

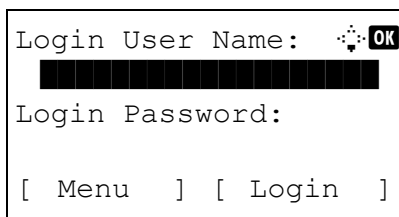

- 3 Press the Δ or ∇ key to select [Date Setting], and press the **OK** key.

When you are performing user management and have not logged in, a login screen will appear. Then, enter the user ID and password to log in, and press [Login] (the **Right Select** key).

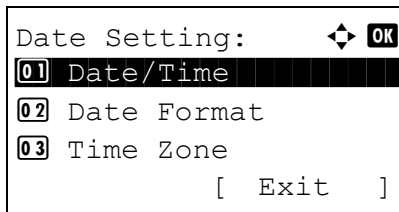

- 4 The Date Settings menu appears.

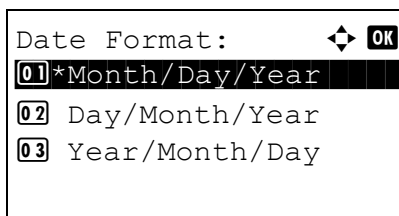

- 5 Press the Δ or ∇ key to select [Date Format]

- 6 Press the **OK** key. Date Format appears.

- 7 Press the Δ or ∇ key to select [Month/Day/Year], [Day/Month/Year] or [Year/Month/Day].

- 8 Press the **OK** key. *Completed.* is displayed and the screen returns to the Date Settings menu.

Time Zone

Set the time difference in the location you are from GMT.

Use the procedure below to set the time difference.

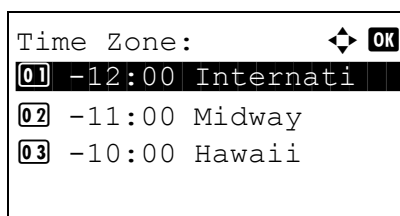
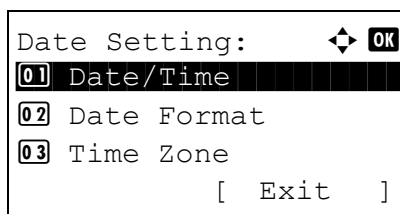
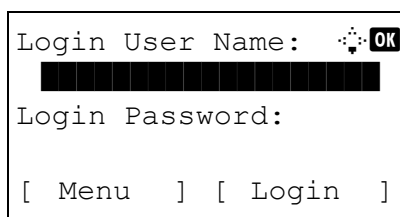
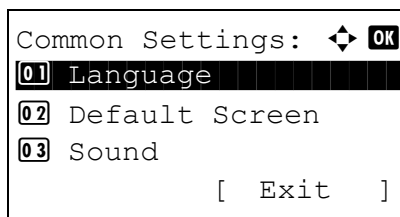
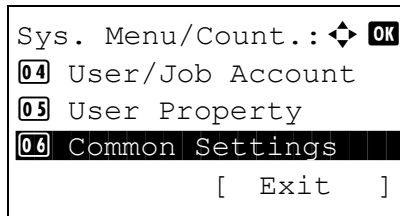

1 In the Sys. Menu/Count. menu, press the Δ or ∇ key to select [Common Settings].

2 Press the **OK** key. The Common Settings menu appears.

3 Press the Δ or ∇ key to select [Date Setting], and press the **OK** key.

When you are performing user management and have not logged in, a login screen will appear. Then, enter the user ID and password to log in, and press [Login] (the **Right Select** key).

4 The Date Settings menu appears.

5 Press the Δ or ∇ key to select [Time Zone].

6 Press the **OK** key. Time Zone appears.

7 Press the Δ or ∇ key to select your location.

- 8 Press the **OK** key. *Completed.* is displayed and the screen returns to the Date Settings menu.

NOTE: If you select a region that does not utilize summer time, the summer time setting screen will not appear.

Summer Time

Set whether or not to apply summer time to the display of the date.

Use the procedure below to set Summer Time.

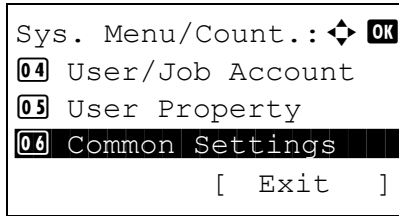

- 1 In the Sys. Menu/Count. menu, press the Δ or ∇ key to select [Common Settings].

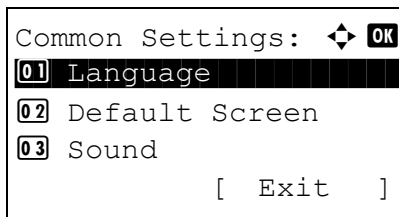

- 2 Press the **OK** key. The Common Settings menu appears.

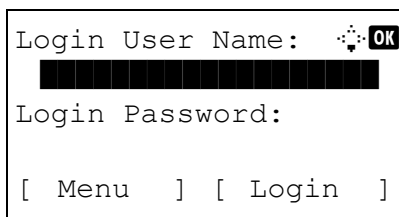

- 3 Press the Δ or ∇ key to select [Date Setting], and press the **OK** key.

When you are performing user management and have not logged in, a login screen will appear. Then, enter the user ID and password to log in, and press [Login] (the **Right Select** key).

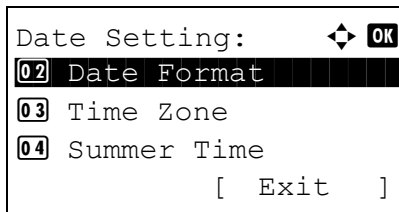

- 4 The Date Settings menu appears.

- 5 Press the Δ or ∇ key to select [Summer Time].

- 6 Press the **OK** key. Summer Time appears.

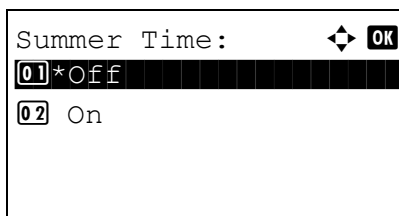

- 7 Press the Δ or ∇ key to select [Off] or [On].

- 8 Press the **OK** key. *Completed.* is displayed and the screen returns to the Date Settings menu.

Auto Error Clear

If an error occurs during printing, the print job stops to wait for the next step to be taken by the user. In the Auto Error Clear mode, automatically clear the error after a set amount of time elapses.

The following errors are automatically cleared.

Cannot duplex print on this paper.
Send error.
Cannot connect to Authentication Server.
Incorrect account ID. Job is canceled.
Job Accounting restriction exceeded. Cannot print.
Job Accounting restriction exceeded. Cannot scan.
Job not stored. Press [OK].
Job Accounting restriction exceeded. Job is canceled.
Sub address/Polling box limit exceeded. Job is canceled.
Memory is full. Print job cannot be processed completely.
Scanner memory is full. Job is canceled.
Print overrun.
KPDLE error.
USB memory error. Job is canceled.
No multi copies. Press [OK].

8

Auto Error Clear ON/OFF

Select whether to use Auto Error Clear or not.

Use the procedure below to specify the auto error clear setting.

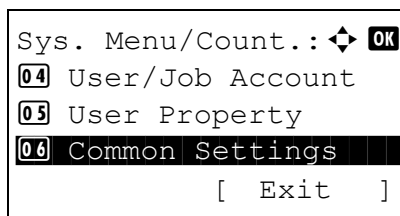

- 1 In the Sys. Menu/Count. menu, press the Δ or ∇ key to select [Common Settings].

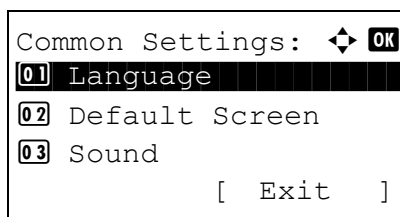

- 2 Press the **OK** key. The Common Settings menu appears.

- 3 Press the Δ or ∇ key to select [Timer Setting], and press the **OK** key.

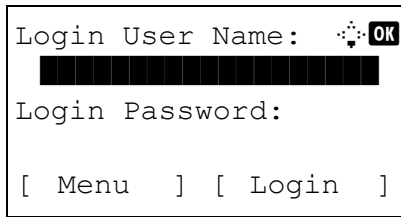

When you are performing user management and have not logged in, a login screen will appear. Then, enter the user ID and password to log in, and press [Login] (the **Right Select** key).

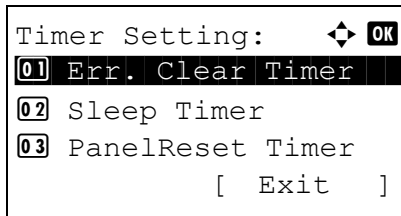

4 The Timer Settings menu appears.

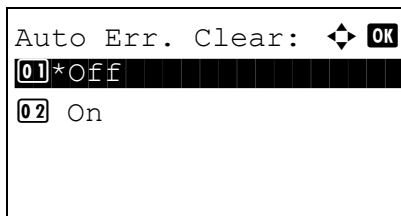

5 Press the Δ or ∇ key to select [Auto Err. Clear].

6 Press the **OK** key. Auto Err. Clear appears.

7 Press the Δ or ∇ key to select [Off] or [On].

8 Press the **OK** key. *Completed.* is displayed and the screen returns to the Timer Settings menu.

Error Clear Timer

If you select [On] for Auto Error Clear, set the amount of time to wait before automatically clearing errors. Options are between 5 and 495 seconds (every five seconds). The default setting is 30 seconds.

If you set 0 as the time, errors are not displayed.

NOTE: If you select [Off] for *Auto Error Clear*, the time display does not appear.

Use the procedure below to set the automatic error clear delay.

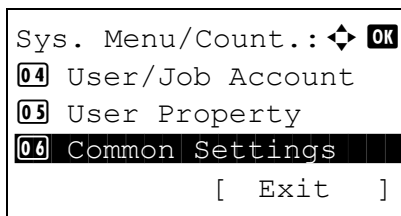

1 In the Sys. Menu/Count. menu, press the Δ or ∇ key to select [Common Settings].

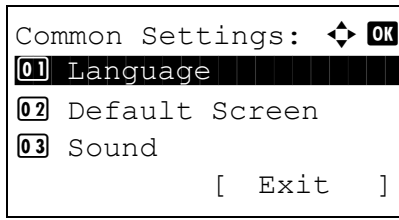

2 Press the **OK** key. The Common Settings menu appears.

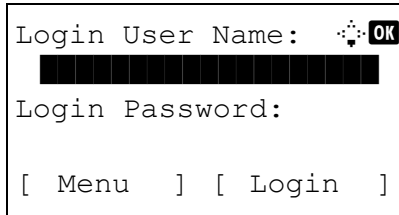

3 Press the Δ or ∇ key to select [Timer Setting], and press the **OK** key.

When you are performing user management and have not logged in, a login screen will appear. Then, enter the user ID and password to log in, and press [Login] (the **Right Select** key).

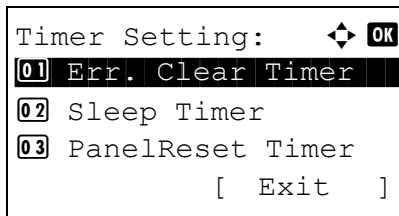

4 The Timer Settings menu appears.

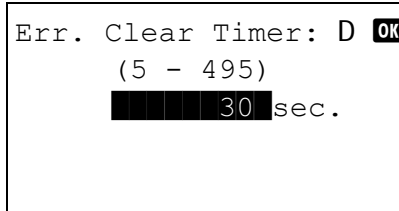

5 Press the Δ or ∇ key to select [Err. Clear Timer].

6 Press the **OK** key. Err. Clear Timer appears.

7 Press the Δ or ∇ key to set the Error Clear Timer. Set the amount of time before clearing errors in seconds. You cannot use the numeric keys to enter this value.

8 Press the **OK** key. *Completed.* is displayed and the screen returns to the Timer Settings menu.

Auto Sleep

If no job runs for a certain period of time, automatically enter Sleep Mode. Refer to *Sleep and Auto Sleep on page 3-5* for Sleep Mode.

Auto Sleep ON/OFF

Select whether to use Auto Sleep or not. The default setting is *Off*.

NOTE: Time remaining before Auto Sleep can be modified as necessary.

Use the procedure below to specify the auto sleep setting.

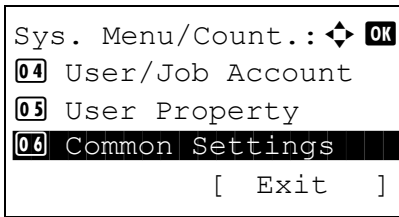

1 In the Sys. Menu/Count. menu, press the Δ or ∇ key to select [Common Settings].

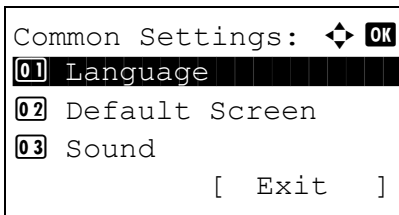

2 Press the **OK** key. The Common Settings menu appears.

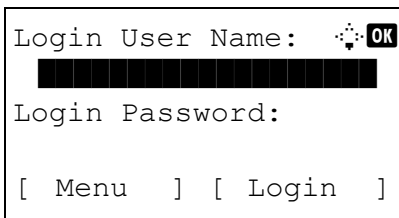

3 Press the Δ or ∇ key to select [Timer Setting], and press the **OK** key.

When you are performing user management and have not logged in, a login screen will appear. Then, enter the user ID and password to log in, and press [Login] (the **Right Select** key).

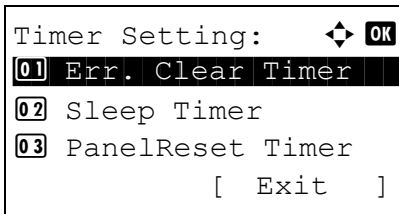

4 The Timer Settings menu appears.

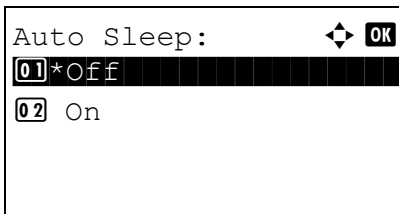

5 Press the Δ or ∇ key to select [Auto Sleep].

6 Press the **OK** key. Auto Sleep appears.

7 Press the Δ or ∇ key to select [Off] or [On].

8 Press the **OK** key. *Completed.* is displayed and the screen returns to the Timer Settings menu.

Sleep Timer

If you select [On] for Auto Sleep, set the amount of time to wait before Auto Sleep. Options are between 1 and 240 minutes (every one minute)

Use the procedure below to set the Auto Sleep time. The default setting is 15 minutes.

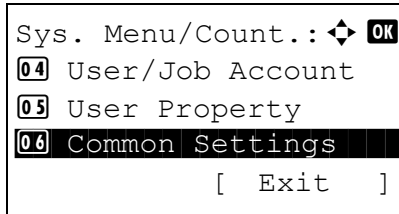

- 1 In the Sys. Menu/Count. menu, press the Δ or ∇ key to select [Common Settings].

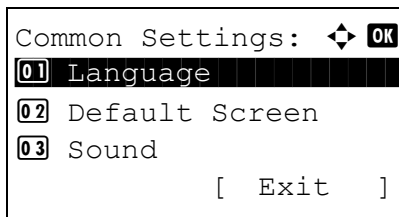

- 2 Press the **OK** key. The Common Settings menu appears.

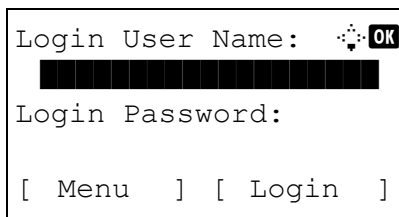

- 3 Press the Δ or ∇ key to select [Timer Setting], and press the **OK** key.

When you are performing user management and have not logged in, a login screen will appear. Then, enter the user ID and password to log in, and press [Login] (the **Right Select** key).

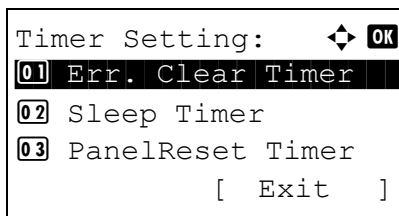

- 4 The Timer Settings menu appears.

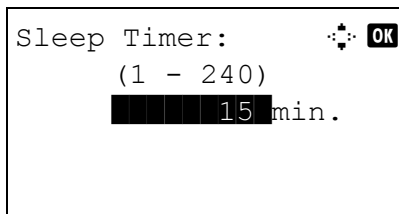

- 5 Press the Δ or ∇ key to select [Sleep Timer].
- 6 Press the **OK** key. Sleep Timer appears.

- 7 Press the Δ or ∇ key to set the Sleep Timer. Set the amount of time before entering the sleep state

in minutes. You cannot use the numeric keys to enter this value.

- 8 Press the **OK** key. *Completed.* is displayed and the screen returns to the Timer Settings menu.

Auto Panel Reset

If no jobs are run for a certain period of time, automatically reset settings and return to the default setting.

NOTE: Refer to page 8-30 for the default settings.

Auto Panel Reset ON/OFF

Select to use Auto Panel Reset or not.

Use the procedure below to specify the auto panel reset setting. The default setting is *On*.

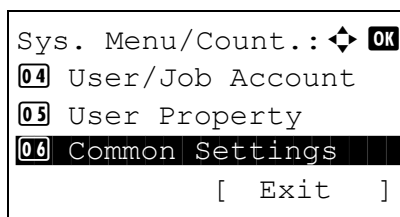

- 1 In the Sys. Menu/Count. menu, press the Δ or ∇ key to select [Common Settings].

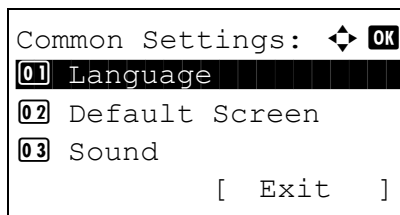

- 2 Press the **OK** key. The Common Settings menu appears.

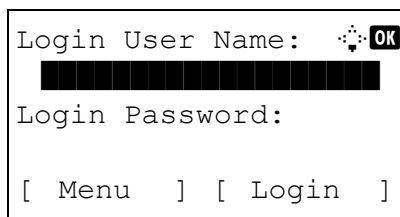

- 3 Press the Δ or ∇ key to select [Timer Setting], and press the **OK** key.

When you are performing user management and have not logged in, a login screen will appear. Then, enter the user ID and password to log in, and press [Login] (the **Right Select** key).

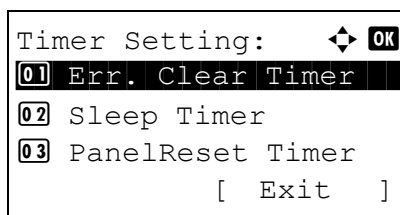

- 4 The Timer Settings menu appears.

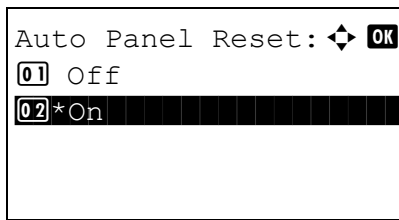

- 5 Press the Δ or ∇ key to select [Auto Panel Reset].
- 6 Press the **OK** key. Auto Panel Reset appears.
- 7 Press the Δ or ∇ key to select [Off] or [On].
- 8 Press the **OK** key. *Completed.* is displayed and the screen returns to the Timer Settings menu.

Panel Reset Timer

If you select [On] for *Auto Panel Reset*, set the amount of time to wait before *Auto Panel Reset*. Options are between 5 and 495 seconds (every five seconds). The default setting is 90 seconds.

NOTE: If you select [Off] for *Auto Panel Reset*, the time display does not appear.

Use the procedure below to set the reset time.

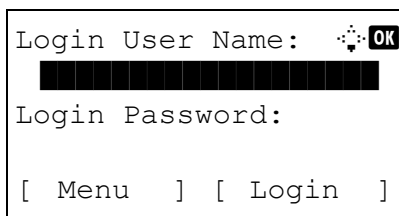
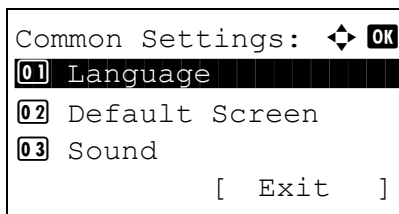
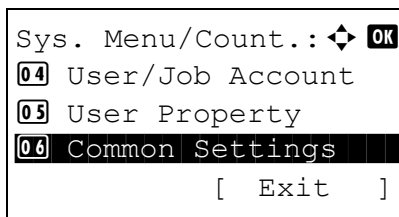

- 1 In the Sys. Menu/Count. menu, press the Δ or ∇ key to select [Common Settings].
- 2 Press the **OK** key. The Common Settings menu appears.
- 3 Press the Δ or ∇ key to select [Timer Setting], and press the **OK** key.

When you are performing user management and have not logged in, a login screen will appear. Then, enter the user ID and password to log in, and press [Login] (the **Right Select** key).

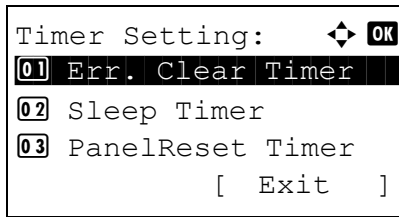

4 The Timer Settings menu appears.

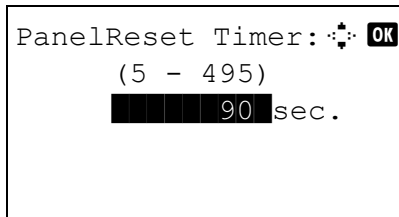

5 Press the Δ or ∇ key to select [Panel Reset Timer].

6 Press the **OK** key. Panel Reset Timer appears.

7 Press the Δ or ∇ key to set the Panel Reset Timer. Set the amount of time before resetting the message display on the panel in seconds. You cannot use the numeric keys to enter this value.

8 Press the **OK** key. *Completed.* is displayed and the screen returns to the Timer Settings menu.

Low Power Timer

You can specify the amount of time to wait before Low Power Mode. Specify a value from 1 - 240 minutes (1 minute increments). The default setting is 2 minutes. For more information on Low Power Mode, refer to *Auto Low Power Mode on page 3-4*.

Use the procedure below to set the Low Power Mode.

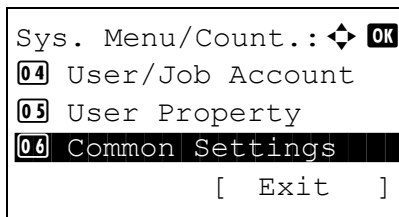

1 In the Sys. Menu/Count. menu, press the Δ or ∇ key to select [Common Settings].

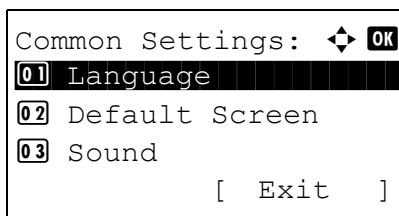

2 Press the **OK** key. The Common Settings menu appears.

3 Press the Δ or ∇ key to select [Timer Setting], and press the **OK** key.

```

Login User Name:  [OK]
[REDACTED]
Login Password:
[ Menu ] [ Login ]

```

When you are performing user management and have not logged in, a login screen will appear. Then, enter the user ID and password to log in, and press [Login] (the **Right Select** key).

```

Timer Setting:  [OK]
[01] Err. Clear Timer
[02] Sleep Timer
[03] PanelReset Timer
      [ Exit ]

```

4 The Timer Settings menu appears.

```

Low Power Timer:  [OK]
      (1 - 240)
      [REDACTED] 2 min.

```

5 Press the Δ or ∇ key to select [Low Power Timer].

6 Press the **OK** key. Low Power Timer appears.

7 Press the Δ or ∇ key or numeric keys to set the Low Power Timer. Set the amount of time before entering the low power state in minutes.

8 Press the **OK** key. *Completed.* is displayed and the screen returns to the Timer Settings menu.

8

Unusable Time

You can specify the prohibition period to use.

Use the procedure below to set the unusable time.

```

Sys. Menu/Count.:  [OK]
[04] User/Job Account
[05] User Property
[06] Common Settings
      [ Exit ]

```

1 In the Sys. Menu/Count. menu, press the Δ or ∇ key to select [Common Settings].

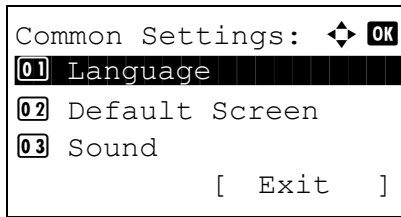

2 Press the **OK** key. The Common Settings menu appears.

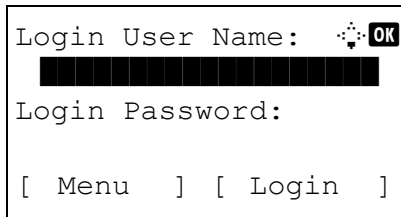

3 Press the Δ or ∇ key to select [Timer Setting], and press the **OK** key.

When you are performing user management and have not logged in, a login screen will appear. Then, enter the user ID and password to log in, and press [Login] (the **Right Select** key).

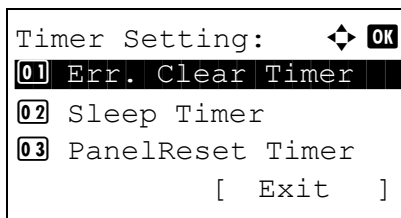

4 The Timer Settings menu appears.

5 Press the Δ or ∇ key to select [Unusable Time].

6 Press the **OK** key. Unusable Time appears.

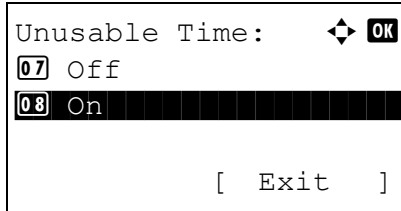

7 Press the Δ or ∇ key to select [On].

8 Press the **OK** key. Start Time appears.

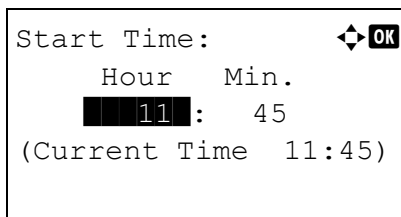

9 Press the Δ or ∇ key or numeric keys to set the Start Time.

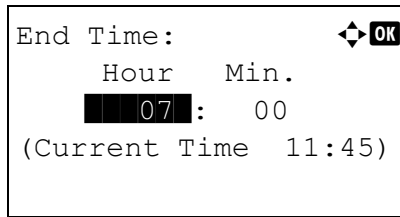

10 Press the **OK** key. End Time appears.

11 Press the Δ or ∇ key or numeric keys to set the End Time.

12 Press the **OK** key. Unlock Code appears.

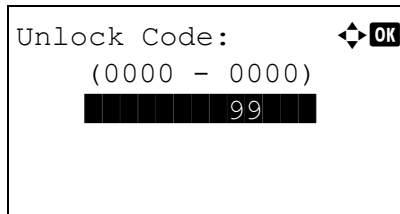

13 Press the Δ or ∇ key or numeric keys to set the unlock code.

14 Press the **OK** key. *Completed.* is displayed and the screen returns to the Timer Settings menu.

Editing Destination (Address Book/Adding One-Touch Keys)

Save frequently used destinations to Address Book or One-touch keys. The saved destinations can be changed. The destinations are available for Send as E-mail, Send to Folder, and Fax Transmission (optional).

Adding an Individual Destination

A maximum of 2,000 individual addresses can be registered. Each address can include the information such as destination name, E-mail address, FTP server folder path, computer folder path, and FAX No. (optional).

NOTE:

- If user login administration is enabled, you can only edit destinations in the Address Book by logging in with administrator privileges.
- Refer to *Character Entry Method on Appendix-5* for details on entering characters.

Use the procedure below to register a new individual contact.

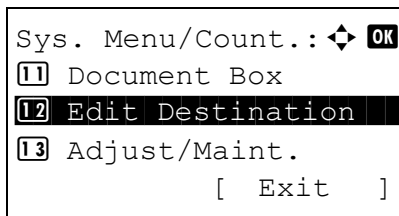

- 1 In the Sys. Menu/Count. menu, press the Δ or ∇ key to select [Edit Destination].

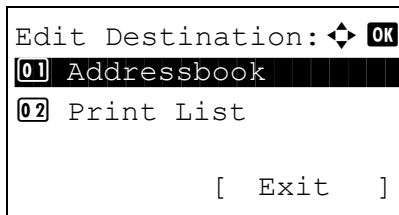

- 2 Press the **OK** key. The Edit Destination menu appears.

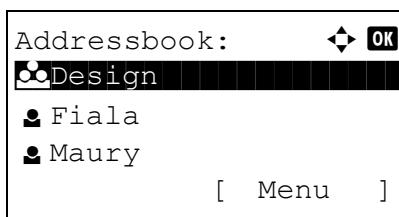

- 3 Press the Δ or ∇ key to select [Address Book].
- 4 Press the **OK** key. The Address Book list screen appears.

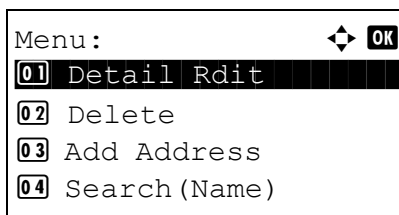

- 5 Press [Menu] (the **Right Select** key). Menu appears.

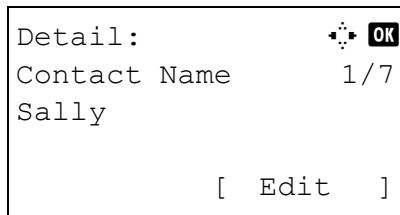
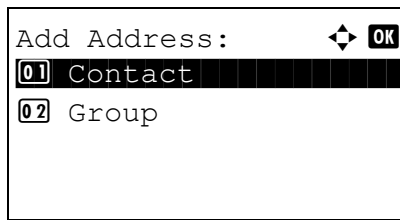

Entering Contact Name

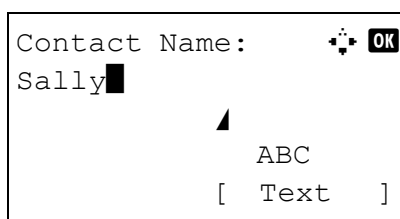
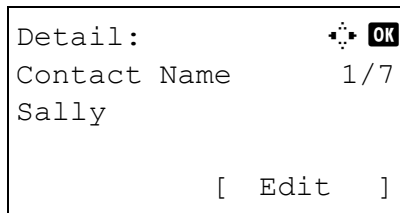

- 6 Press the Δ or ∇ key to select [Add Address].
- 7 Press the **OK** key. Add Address appears.

- 8 Press the Δ or ∇ key to select [Contact].
- 9 Press the **OK** key. This displays the screen for editing destinations.

NOTE: If the maximum number of destinations has already been registered, the screen will display *Registered numbers exceeded.* and return to the Address Book.

- 10 Enter each item and then press the **OK** key. *Registered.* is displayed and the screen returns to the Address Book list screen.

Refer to the descriptions below for how to enter each item.

- 1 Press the \triangleleft or \triangleright key to select [Contact Name].

- 2 Press [Edit] (the **Right Select** key). An entry screen appears.

- 3 Enter the contact name.

If creating a new contact name, the address number allocated to the destination is already entered.

- 4 Press the **OK** key. The contact name is registered.

Entering E-mail Address

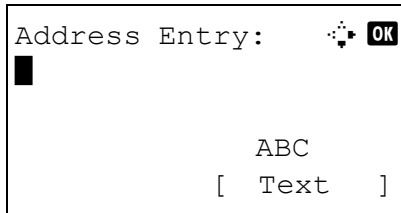
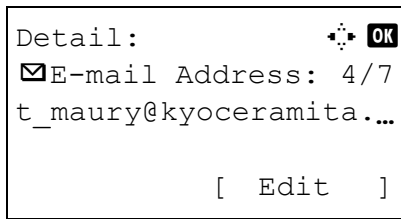

1 Press the ◀ or ▶ key to display E-mail Address.

2 Press [Edit] (the **Right Select** key). An entry screen appears.

3 Enter the e-mail address.

NOTE: Destination can be specified using the Address Book or the One-touch keys. Refer to *Specifying Destination on page 3-28*.

4 Press the **OK** key. The e-mail address is registered.

Entering Folder (SMB/FTP) Address

Folder (SMB) Address

The table below explains the items to be entered.

Item	Description	Max. No. of Characters
Host Name*	Host name or IP address of the sending computer	64 chars
Path	Path to the folder used to save files E.g. "User\ScanData"	128 chars
Login User Name	User name for folder access For example, <i>abcdnetjames.smith</i>	64 chars
Login Password	Password for folder access	64 chars

* If you specify a port number other than the default (139), use the "Host name: port number" format. (E.g. SMBhostname: 140)

Folder (FTP) Address

The table below explains the items to be entered.

Item	Description	Max. No. of Characters
Host Name*	Host name or IP address of the sending computer	64 chars
Path	Path to the folder used to save files E.g. "User\ScanData"	128 chars
Login User Name	User name for folder access For example, <i>abcdnetjames.smith</i>	64 chars
Login Password	Password for folder access	64 chars
Encryption	If secure communication is On, encryption method can be selected from Auto, DES, 3DES and AES.	-

* If you specify a port number other than the default (21), use the "Hostname: port number" format. (E.g. FTPhostname: 140)

1 Press the ◀ or ▶ key to display Folder(SMB) or Folder(FTP).

2 Press [Edit] (the **Right Select** key). An entry screen appears.

3 Enter the host name.

or

NOTE: Destination can be specified using the Address Book or the One-touch keys. Refer to *Specifying Destination* on page 3-28.

```
Path: SD3\report █
                                ABC
                                [ Text ]
```

4 Press the **OK** key. Path appears.

```
Login User Name: █
Maury █
                                ABC
                                [ Text ]
```

5 Enter the path name.

6 Press the **OK** key. Login User Name appears.

```
Login Password: █
●●●●●●●●●●●●●●●● █
                                ABC
                                [ Text ]
```

7 Enter the login user name.

8 Press the **OK** key. Login Password appears.

```
Check the connection.
Are you sure?

[ Yes ] [ No ]
```

9 Enter the login password.

10 Press the **OK** key. A confirmation screen appears.

NOTE: If the screen for confirming the entry of a new destination (*page 8-64*) is set to [On], screens to confirm the entered host name and path name appear. Enter the same host name and path name again and press the **OK** key on their respective screens.

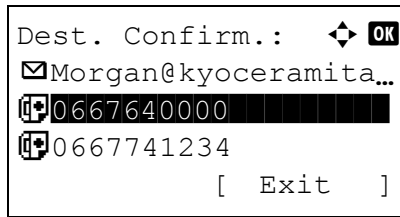

- 11 Press [Yes] (the **Left Select** key). This makes a connection with the entered destination.

If the connection is successful, *Connected.* is displayed on the screen. Press [OK] (the **Right Select** key). *Completed.* is displayed and the folder (SMB/FTP) address is registered.

If the connection failed, *Cannot connect.* is displayed. Press [OK] (the **Right Select** key). The screen shown in step 2 reappears. Check and re-enter the destination.

Address Number

Address Number is an ID for a destination. When creating a new destination, the smallest unused address number is automatically allocated. You can select any available number out of 100 numbers for individuals and 20 numbers for groups.

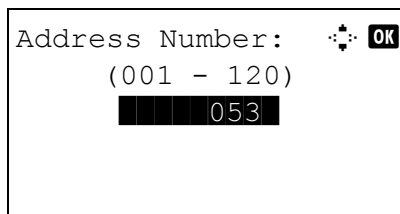
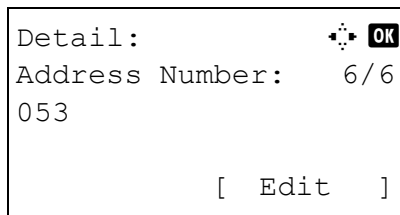

- 1 Press the < or > key to display Address Number.

- 2 Press [Edit] (the **Right Select** key). An entry screen appears.

- 3 Press the Δ or ∇ key or the numeric keys to enter the address number.

- 4 Press the **OK** key. The address number is registered.

NOTE: If you enter an address number that is already registered, the screen will display *This address number is already registered.* and return to the screen of step 2.

Adding a Group

Compile two or more individuals into a group. Designations in the group can be added at the same time. When adding a group, a maximum of 500 groups can be added in the Address Book.

NOTE: If user login administration is enabled, you can only edit destinations in the Address Book by logging in with administrator privileges.

Before adding a group in the Address Book, the individuals to be included in the group must be added first. Up to 100 destinations for the e-mail, 500 destinations for the FAX, and the total of 10 destinations for the FTP and SMB can be registered per a group.

Use the procedure below to register a group.

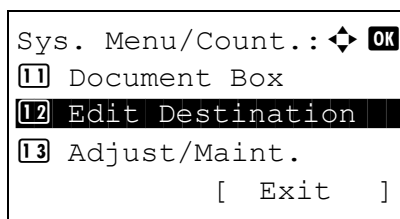

1 In the Sys. Menu/Count. menu, press the Δ or ∇ key to select [Edit Destination].

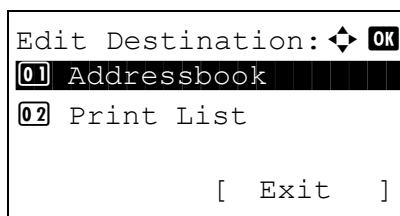

2 Press the **OK** key. The Edit Destination menu appears.

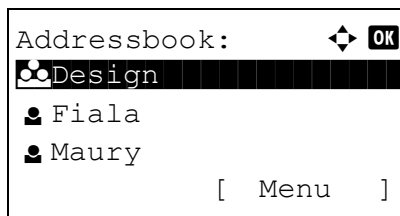

3 Press the Δ or ∇ key to select [Address Book].

4 Press the **OK** key. The Address Book list screen appears.

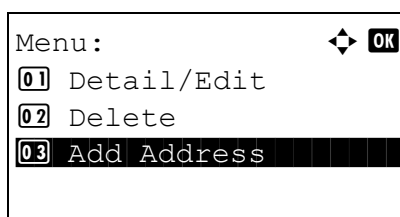

5 Press [Menu] (the **Right Select** key). Menu appears.

6 Press the Δ or ∇ key to select [Add Address].



7 Press the **OK** key. Add Address appears.

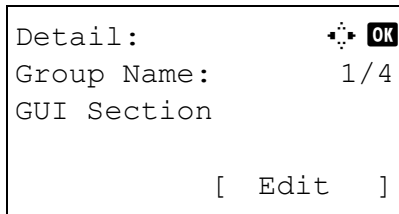

8 Press the Δ or ∇ key to select [Group].

9 Press the **OK** key. This displays the screen for editing groups.

NOTE: If the maximum number of groups has already been registered, the screen will display *Registered numbers exceeded.* and return to the Address Book.

10 Enter each item and then press the **OK** key. *Registered.* is displayed and the screen returns to the Address Book list screen.

Refer to the descriptions below for how to enter each item.

Entering Group Name

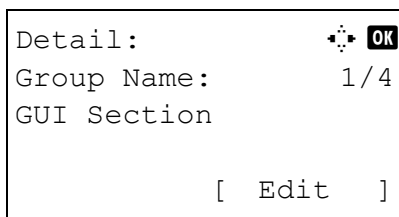

1 Press the \triangleleft or \triangleright key to display Group Name.

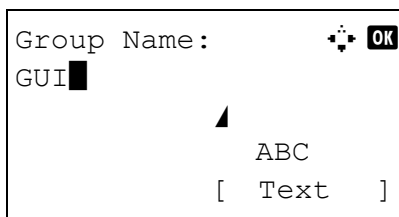

2 Press [Edit] (the **Right Select** key). An entry screen appears.

3 Enter the group name.

If creating a new group name, the address number allocated to the destination is already entered.

4 Press the **OK** key. The group name is registered.

Entering Group Member

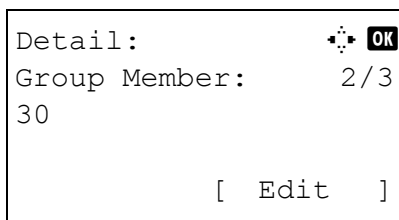

1 Press the < or > key to display Group Member.

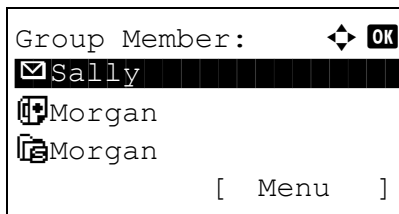

2 Press [Edit] (the **Right Select** key). This displays the list of destinations registered to the group.

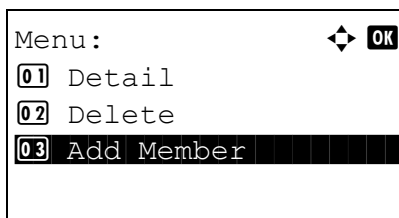

3 Press [Menu] (the **Right Select** key). The group editing menu appears.

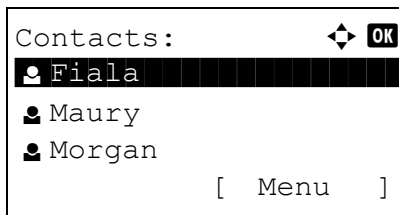

4 Press the Δ or ∇ key to select [Add Member].

5 Press the **OK** key. This displays the list of destinations registered in the Address Book.

NOTE: If 100 members have already been registered in the group, the screen will display *Registered numbers exceeded.* and return to the Group Member.

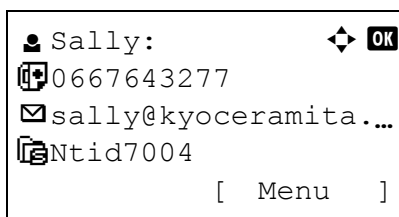

6 Press the Δ or ∇ key to select the destination you want to add to the group.

7 Press the **OK** key. This displays the sending address registered to the selected destination.

8 Press the Δ or ∇ key to select the sending address.

9 Press the **OK** key. The selected destination is added to the group and the screen returns to Group Member.

NOTE: If you select an individual destination that has already been registered to the group, the screen will display *This address is already registered.* and return to the screen of step 7.

Deleting member from group

To delete a member registered to the group, follow the procedure below.

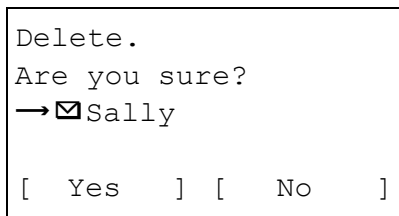
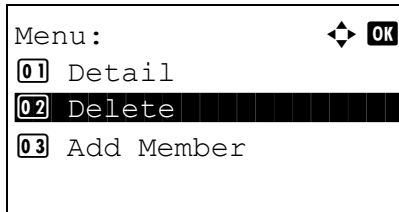
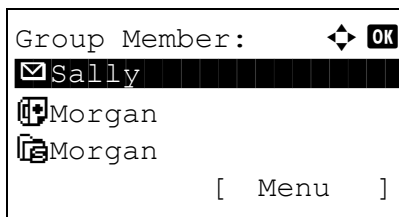

- 1 While Group Member is displayed, press [Edit] (the **Right Select** key). This displays the list of destinations registered to the group.
- 2 Press the Δ or ∇ key to select the destination you want to delete.
- 3 Press [Menu] (the **Right Select** key). The group editing menu appears.
- 4 Press the Δ or ∇ key to select [Delete].
- 5 Press the **OK** key. A confirmation message appears.
- 6 Press [Yes] (the **Left Select** key). *Completed.* is displayed and the screen returns to Group Member.

Entering Address Number

Address Number is an ID for a destination. When creating a new destination, the smallest unused address number is automatically allocated. You can select any available number out of 2,500 numbers for individuals and 500 numbers for groups.

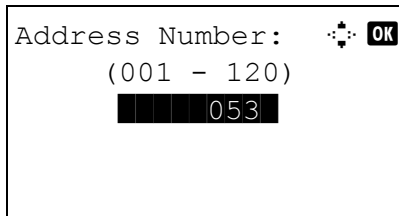
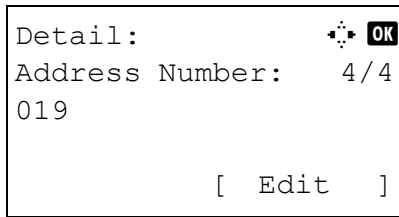

- 1 Press the ◀ or ▶ key to display Address Number.
- 2 Press [Edit] (the **Right Select** key). An entry screen appears.
- 3 Press the ▲ or ▼ key or the numeric keys to enter the address number.
- 4 Press the **OK** key. The address number is registered.

NOTE: If you enter an address number that is already registered, the screen will display *This address number is already registered.* and return to the screen of step 2.

Editing a Destination

Edit/delete the destinations (individuals) you added to the Address Book.

Use the procedure below to edit a destination.

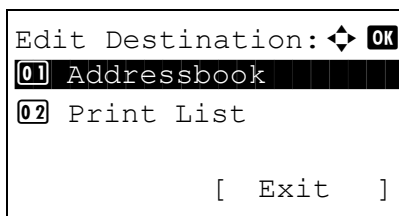
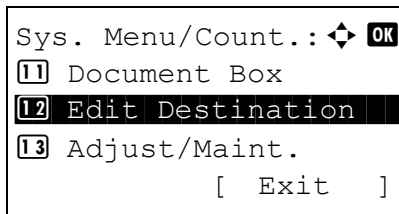

- 1 In the Sys. Menu/Count. menu, press the ▲ or ▼ key to select [Edit Destination].
- 2 Press the **OK** key. The Edit Destination menu appears.
- 3 Press the ▲ or ▼ key to select [Address Book].

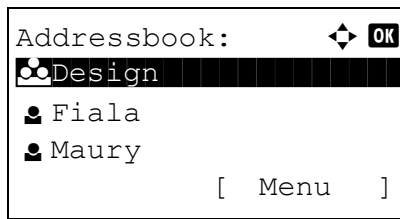

4 Press the **OK** key. The Address Book list screen appears.

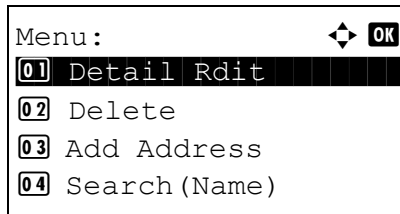

5 Press the Δ or ∇ key to select the destination you want to edit.

6 Press [Menu] (the **Right Select** key). Menu appears.

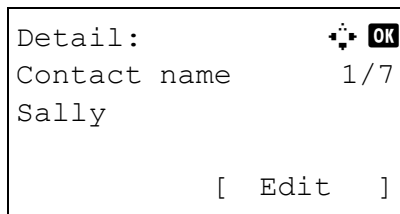

7 Press the Δ or ∇ key to select [Detail/Edit].

8 Press the **OK** key. This displays the screen for editing the selected destination.

The screen shown is the one when an individual's destination is selected.

9 Edit items as necessary.

For how to edit each item, refer to *Adding an Individual Destination on page 8-112* and *Adding a Group on page 8-118*.

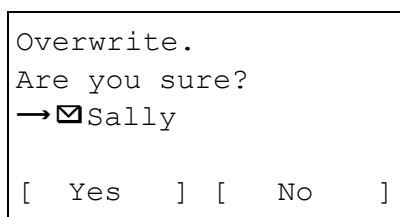

10 After completing editing, press the **OK** key. A confirmation screen appears.

11 Press [Yes] (the **Left Select** key). *Registered.* is displayed and the screen returns to the Address Book list screen.

Adding a Destination on One-touch Key

This machine has 11 one-touch keys and you can register 2 destinations to each of them.

The one-touch keys are arranged as shown below:

No.1	No.2	No.3	No.4
No.12	No.13	No.14	No.15
No.5	No.6	No.7	No.8
No.16	No.17	No.18	No.19
No.9	No.10	No.11	SHIFT
No.20	No.21	No.22	

NOTE: Refer to *One-Touch Key* on page 3-7 for how to use them.

Registering new destination

Use the procedure below to register a new destination under a One-touch key.

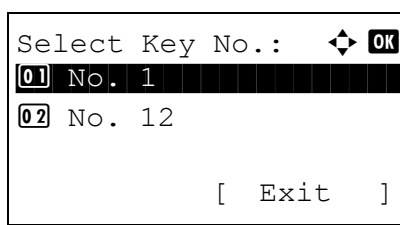

- 1 In the basic screen, press the one-touch key to which you want to register the destination and hold it (2 seconds or longer). Select Key Set. appears.

The screen shown is the one when No.1/No.12 is pressed and held.

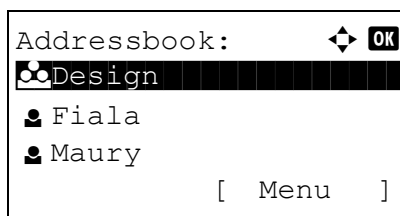

- 2 Press the Δ or ∇ key to select the key number to which you want to register the destination.
- 3 Press the **OK** key. The Address Book list screen appears.

- 4 Press the Δ or ∇ key to select the destination you want to register.

NOTE: If you want to search from the Address Book, refer to *Search in Address Book* on page 3-29.

- 5 Press the **OK** key. The selected destination is registered to the one-touch key. *Registered.* is displayed and the screen returns to the basic screen.

Editing One-touch Key

Edit/delete the destinations you added to One-touch Key.

Use the procedure below to edit the one-touch key.

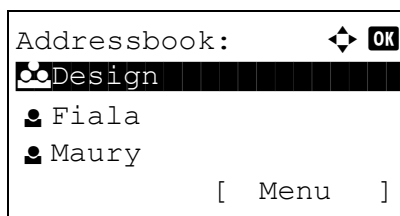
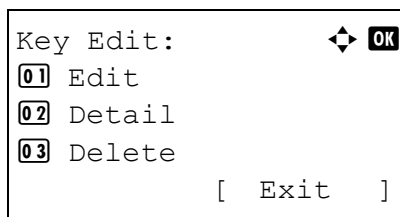
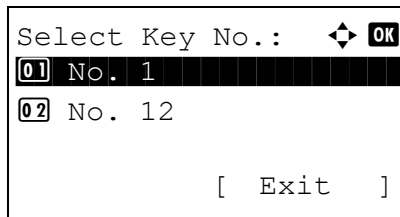

- 1 In the basic screen, press the one-touch key where you want to edit the destination and hold it (2 seconds or longer). Select Key Set. appears.

The screen shown is the one when No.1/No.12 is pressed and held.

- 2 Press the Δ or ∇ key to select the key number where you want to edit the destination.
- 3 Press the **OK** key. The Key Edit appears.

- 4 Press the Δ or ∇ key to select [Edit].

NOTE: If you select [Delete] here and press the **OK** key, you can delete the registration of the destination. If you press [Yes] (the **Left Select** key) in the screen that appears, *Completed.* is displayed and the registration of the destination is deleted.

- 5 Press the **OK** key. The Address Book list screen appears.

- 6 Press the Δ or ∇ key to select the destination you want to newly register.

NOTE: If you want to search from the Address Book, refer to *Search in Address Book on page 3-29.*

```
Overwrite.  
Are you sure?  
→No. 1  
  
[ Yes ] [ No ]
```

- 7** Press the **OK** key. A confirmation screen appears.

- 8** Press [Yes] (the **Left Select** key). The selected destination is registered to the one-touch key, overwriting the previous one. *Registered.* is displayed and the screen returns to the basic screen.

Restarting the System

```

Sys. Menu/Count.:  OK
01 Report
02 Counter
03 System
[ Exit ]

```

```

Login User Name:  OK
[Redacted]
Login Password:
[ Menu ] [ Login ]

```

```

System:  OK
03 Security Level
04 Restart
05 Op Functions
[ Exit ]

```

```

Restart.
Are you sure?
[ Yes ] [ No ]

```

Restart the printer without turning the main power switch off. Use this to deal with any unstable operation by the machine. (Same as the computer restart.)

Use the procedure below to restart the system.

- 1 In the Sys. Menu/Count. menu, press the Δ or ∇ key to select [System], and press the **OK** key.

When you are performing user management and have not logged in, a login screen will appear. Then, enter the user ID and password to log in, and press [Login] (the **Right Select** key).

- 2 The System menu appears.

- 3 Press the Δ or ∇ key to select [Restart].

- 4 Press the **OK** key. A confirmation screen appears.

- 5 Press [Yes] (the **Left Select** key). The printer is restarted.

If you press [No] (the **Right Select** key), the printer does not restart and the screen returns to the System menu.

Network Setup

The following network settings are available.

- LAN Interface Setup ...8-128
- TCP/IP (IPv4) Setup ...8-129
- TCP/IP (IPv6) Setup ...8-129
- NetWare Setup ...8-130
- AppleTalk Setup ...8-132
- Protocol Detail ...8-135

LAN Interface Setup

Specify the settings for the LAN interface to be used. The default setting is *Auto*.

Use the procedure below to select the interface.

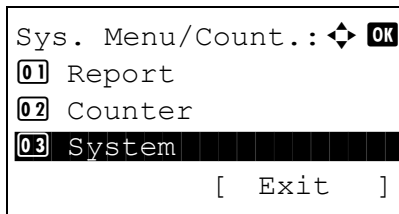

- 1 In the Sys. Menu/Count. menu, press the Δ or ∇ key to select [System], and press the **OK** key.

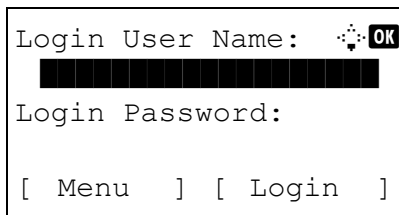

When you are performing user management and have not logged in, a login screen will appear. Then, enter the user ID and password to log in, and press [Login] (the **Right Select** key).

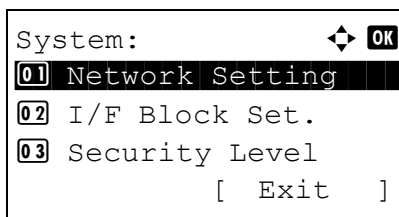

- 2 The System menu appears.

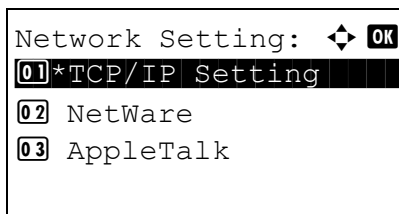

- 3 Press the Δ or ∇ key to select [Network Setting].
- 4 Press the **OK** key. The Network Setting menu appears.

- 5 Press the Δ or ∇ key to select [LAN Interface].

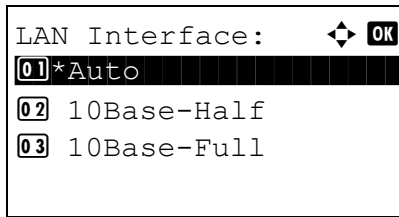

- Press the **OK** key. LAN Interface appears.

- Press the Δ or ∇ key to select the desired LAN interface.

The available LAN interfaces are as follows:

Auto
 10Base-Half
 10Base-Full
 100Base-Half
 100Base-Full

- Press the **OK** key. *Completed.* is displayed and the screen returns to the Network Setting menu.

TCP/IP (IPv4) Setup

Set up TCP/IP to connect to the Windows network.

Refer to *TCP/IP (IPv4) Setup (by Entering IP Addresses)* on page 2-12 about the procedures.

TCP/IP (IPv6) Setup

Set up TCP/IP (IPv6) to connect to the network. The default setting is *Off*.

Use the procedure below to setup the TCP/IP (IPv6) setting.

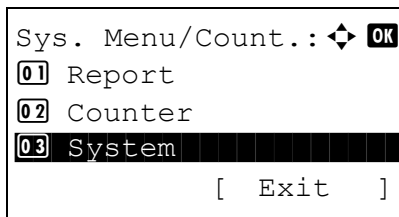

- In the Sys. Menu/Count. menu, press the Δ or ∇ key to select [System], and press the **OK** key.

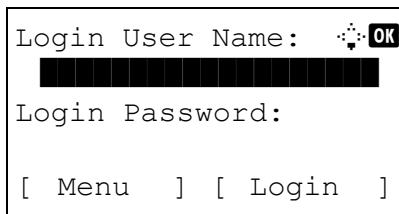

When you are performing user management and have not logged in, a login screen will appear. Then, enter the user ID and password to log in, and press [Login] (the **Right Select** key).

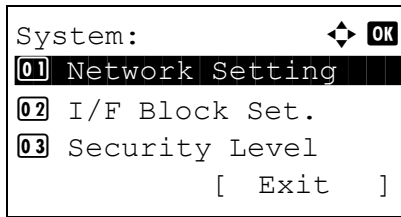

2 The System menu appears.

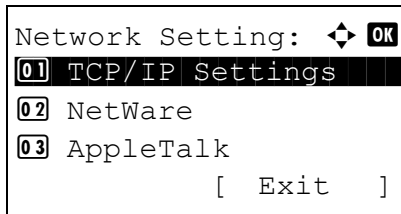

3 Press the Δ or ∇ key to select [Network Setting].

4 Press the **OK** key. The Network Setting menu appears.

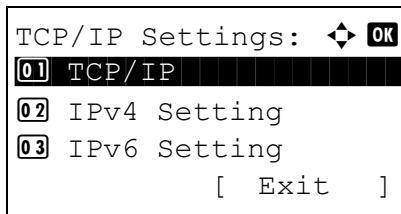

5 Press the Δ or ∇ key to select [TCP/IP Settings].

6 Press the **OK** key. The TCP/IP Settings menu appears.

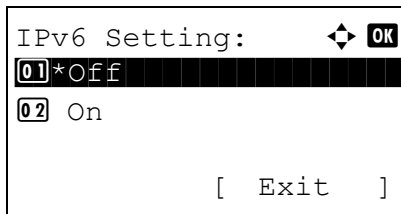

7 Press the Δ or ∇ key to select [IPv6 Setting].

8 Press the **OK** key. IPv6 Setting appears.

9 Press the Δ or ∇ key to select [On] or [Off].

10 Press the **OK** key. *Completed.* is displayed and the screen returns to the TCP/IP Settings menu.

NetWare Setup

Select the NetWare network connection. After that, select frame types for NetWare network from Auto, Ethernet-II, 802.3, 802.2, or SNAP. The default settings is "Off".

Use the procedure below to setup the NetWare setting.

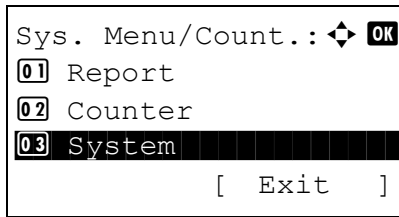

- 1 In the Sys. Menu/Count. menu, press the Δ or ∇ key to select [System], and press the **OK** key.

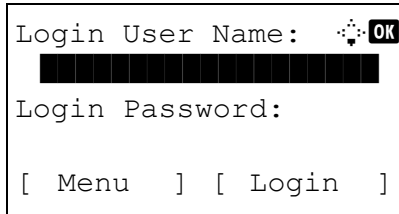

When you are performing user management and have not logged in, a login screen will appear. Then, enter the user ID and password to log in, and press [Login] (the **Right Select** key).

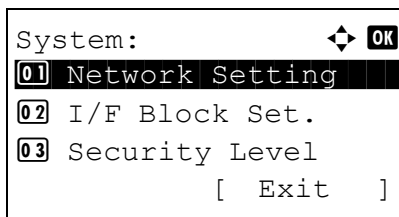

- 2 The System menu appears.

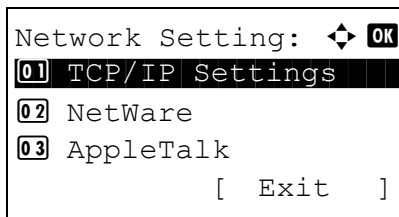

- 3 Press the Δ or ∇ key to select [Network Setting].
- 4 Press the **OK** key. The Network Setting menu appears.

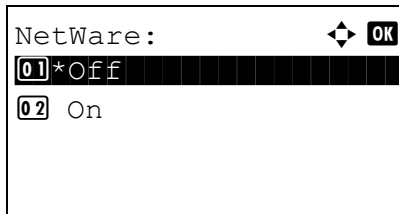

- 5 Press the Δ or ∇ key to select [NetWare].
- 6 Press the **OK** key. NetWare appears.

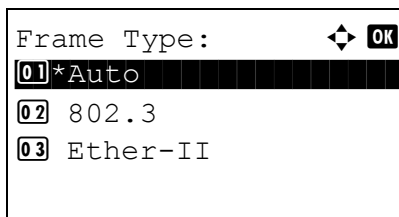

- 7 Press the Δ or ∇ key to select [On] or [Off].
- If you select [On] and press the **OK** key, Frame Type appears. Press the Δ or ∇ key to select the desired frame type.

The available frame types are as follows:

- Auto
- 802.3

Ether-II
802.2
SNAP

- 8 Press the **OK** key. *Completed.* is displayed and the screen returns to the Network Setting menu.

For detailed information on restarting the system, refer to *Restarting the System on page 8-127.*

AppleTalk Setup

Select the Apple Talk network connection.

Refer to *AppleTalk Setup on page 2-22* about the procedures.

WSD Scan Setup

Select whether or not to use WSD Scan. The default setting is *On*.

Use the procedure below to setup the WSD-SCAN setting. The machine must be restarted after the setting is changed.

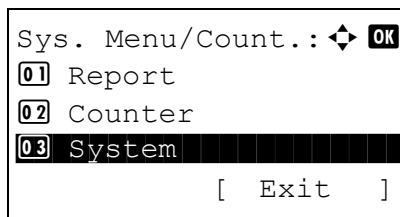

- 1 In the Sys. Menu/Count. menu, press the Δ or ∇ key to select [System], and press the **OK** key.

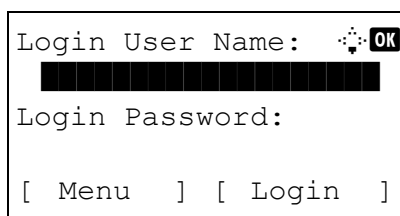

When you are performing user management and have not logged in, a login screen will appear. Then, enter the user ID and password to log in, and press [Login] (the **Right Select** key).

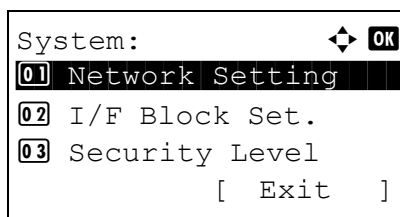

- 2 The System menu appears.

- 3 Press the Δ or ∇ key to select [Network Setting].

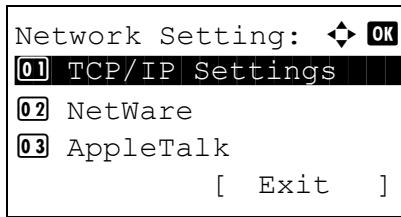

4 Press the **OK** key. The Network Setting menu appears.

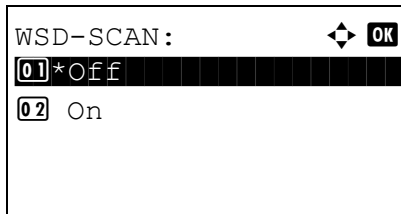

5 Press the Δ or ∇ key to select [WSD-SCAN].

6 Press the **OK** key. The WSD-SCAN menu appears.

7 Press the Δ or ∇ key to select [On] or [Off].

8 Press the **OK** key. *Completed.* is displayed and the screen returns to the Network Settings menu.

WSD Print Setup

Select whether or not to use WSD Print. The default setting is *On*.

Use the procedure below to setup the WSD-PRINT setting. The machine must be restarted after the setting is changed.

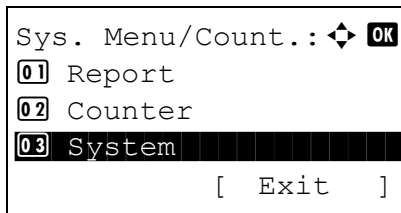

1 In the Sys. Menu/Count. menu, press the Δ or ∇ key to select [System], and press the **OK** key.

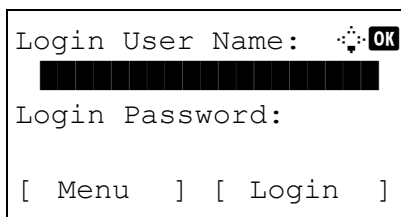

When you are performing user management and have not logged in, a login screen will appear. Then, enter the user ID and password to log in, and press [Login] (the **Right Select** key).

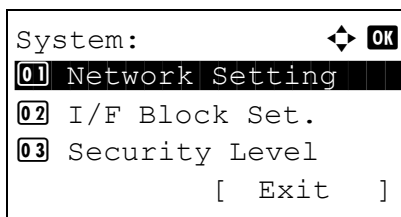

2 The System menu appears.

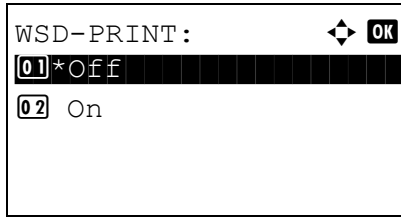
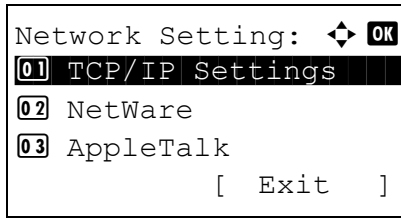

- 3 Press the Δ or ∇ key to select [Network Setting].
- 4 Press the **OK** key. The Network Setting menu appears.
- 5 Press the Δ or ∇ key to select [WSD-PRINT].
- 6 Press the **OK** key. The WSD-PRINT menu appears.
- 7 Press the Δ or ∇ key to select [On] or [Off].
- 8 Press the **OK** key. *Completed.* is displayed and the screen returns to the Network Settings menu.

Protocol Detail

Make other network related settings.

Item	Description	Default Setting	Restarting the System*
NetBEUI	Selects whether or not to receive documents using NetBEUI.	<i>On</i>	×
LPD	Select whether or not to receive documents using LPD as the network protocol.	<i>On</i>	●
FTP (Server)	Select whether or not to receive documents using FTP.	<i>On</i>	●
FTP (Client)	Select whether or not to send documents using FTP, and the number of the port to be used.	<i>On</i> Port number: 21	×
Raw Port	Select whether or not to receive documents using Raw Port.	<i>On</i>	●
LDAP	Select whether or not to use LDAP.	<i>Off</i>	×
SNMP	Select whether or not to communicate using SNMP.	<i>On</i>	●
SNMPv3	Set SNMPv3.	<i>Off</i>	●
SMB	Select whether or not to send documents using SMB, and the number of the port to be used.	<i>On</i> Port number: 139	×
SMTP (E-mail TX)	Select whether or not to send <i>e-mail</i> using SMTP.	<i>Off</i>	×
POP3 (E-mail RX)	Select whether or not to receive <i>e-mail</i> using POP3.	<i>Off</i>	×
HTTP	Select whether or not to communicate using HTTP.	<i>On</i>	●
HTTPS	Select whether or not to communicate using HTTPS. SSL must be set to [<i>On</i>] in <i>SSL Setting on page 8-138</i> .	<i>On</i>	●

Item	Description	Default Setting	Restarting the System*
IPP	Select whether or not to use IPP, and the number of the port to be used.	Off Port number: 631	●
IPP over SSL	Select whether or not to use IPP over SSL. SSL must be set to [On] in <i>SSL Setting on page 8-138</i> .	On	●

* ●: The machine must be restarted after the setting is changed.
 ×: The machine does not need to be restarted after the setting is changed.

Use the procedure below.

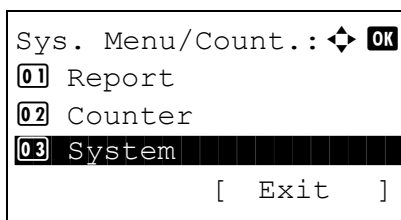

1 In the Sys. Menu/Count. menu, press the Δ or ∇ key to select [System], and press the **OK** key.

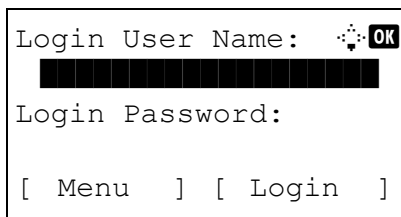

When you are performing user management and have not logged in, a login screen will appear. Then, enter the user ID and password to log in, and press [Login] (the **Right Select** key).

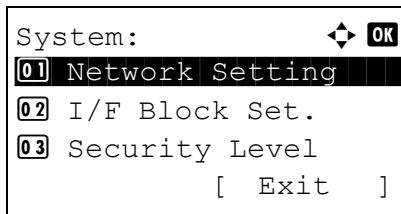

2 The System menu appears.

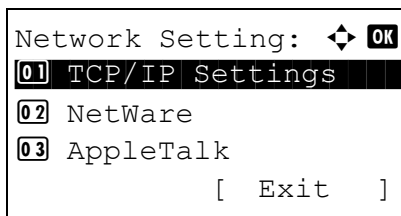

3 Press the Δ or ∇ key to select [Network Setting].

4 Press the **OK** key. The Network Setting menu appears.

5 Press the Δ or ∇ key to select [TCP/IP Settings].

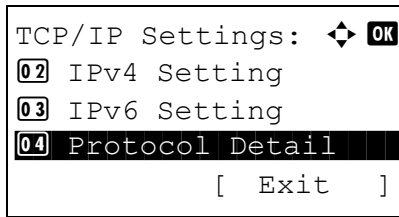

- 6 Press the **OK** key. The TCP/IP Settings menu appears.

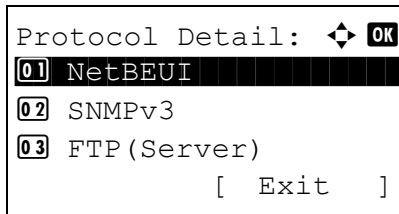

- 7 Press the Δ or ∇ key to select [Protocol Detail].
- 8 Press the **OK** key. The Protocol Detail menu appears.

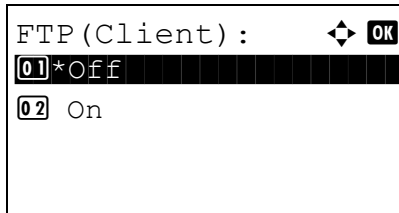

- 9 Press the Δ or ∇ key to select the item for which you want to make settings.
- 10 Press the **OK** key. This displays the setting screen for the item selected in step 9.

The screen shown is the one when [FTP(Client)] is selected.

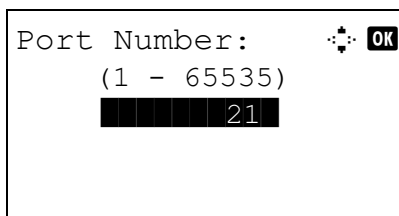

- 11 Press the Δ or ∇ key to select [On] or [Off].

If you select [On] for each of [FTP(Client)] and [IPP] and press the **OK** key, a port number entry screen appears.

Press the Δ or ∇ key or the numeric keys to set the port number.

- 12 Press the **OK** key. *Completed.* is displayed and the screen returns to the Protocol Detail menu.

Network Security

The network security functions can be set up to protect printer operation and the print data.

The following network security settings are available.

- SSL Setting ...8-138
- SNMPv3 Setting ...8-143
- IPSec Setting ...8-144

SSL Setting

This allows you to use SSL network security for communication. You can use SSL Setup to select whether or not SSL is used and to specify the IPP port and HTTP port security settings.

SSL

Make this setting when you use SSL. The default setting is *Off*.

Use the procedure below to make the setting.

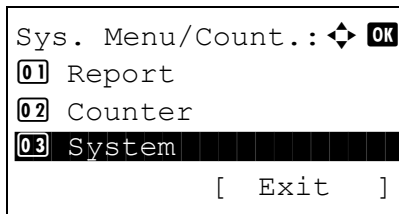

- 1 In the Sys. Menu/Count. menu, press the Δ or ∇ key to select [System], and press the **OK** key.

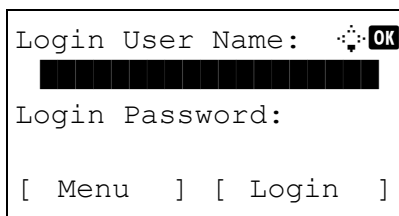

When you are performing user management and have not logged in, a login screen will appear. Then, enter the user ID and password to log in, and press [Login] (the **Right Select** key).

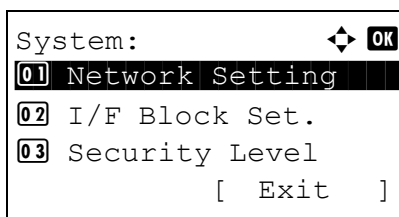

- 2 The System menu appears.
- 3 Press the Δ or ∇ key to select [Network Setting].

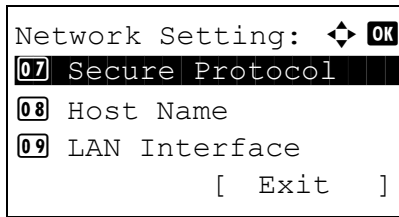

- 4 Press the **OK** key. The Network Setting menu appears.

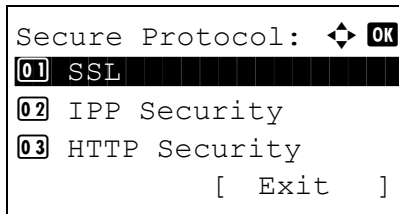

- 5 Press the Δ or ∇ key to select [Secure Protocol].
- 6 Press the **OK** key. Secure Protocol appears.

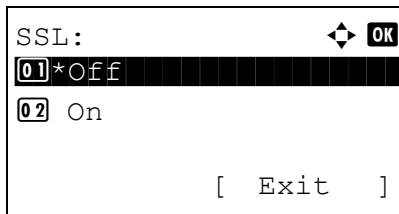

- 7 Press the Δ or ∇ key to select [SSL].
- 8 Press the **OK** key. SSL appears.

- 9 Press the Δ or ∇ key to select [On] or [Off].
- 10 Press the **OK** key. *Completed.* is displayed and the screen returns to the Secure Protocol menu.

IPP Security

Specify the protocol to be used for IPP. The default setting is *IPP/IPP over SSL*.

Use the procedure below to make the setting.

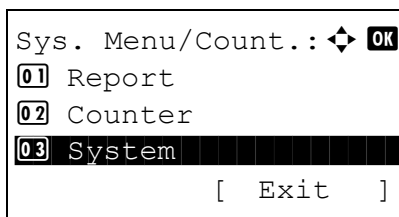

- 1 In the Sys. Menu/Count. menu, press the Δ or ∇ key to select [System], and press the **OK** key.

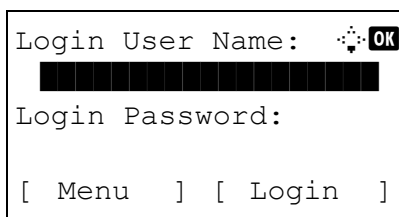

When you are performing user management and have not logged in, a login screen will appear. Then, enter the user ID and password to log in, and press [Login] (the **Right Select** key).

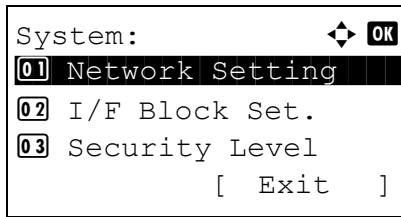

2 The System menu appears.

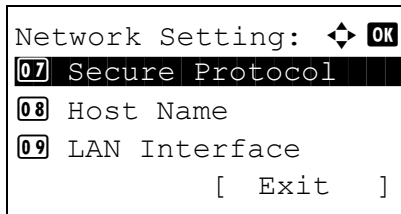

3 Press the Δ or ∇ key to select [Network Setting].

4 Press the **OK** key. The Network Setting menu appears.

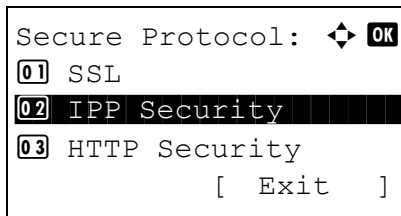

5 Press the Δ or ∇ key to select [Secure Protocol].

6 Press the **OK** key. Secure Protocol appears.

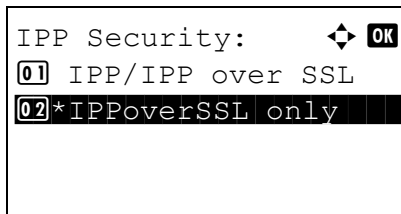

7 Press the Δ or ∇ key to select [IPP Security].

8 Press the **OK** key. IPP Security appears.

9 Press the Δ or ∇ key to select [IPP/IPP over SSL] or [IPPOverSSL only].

10 Press the **OK** key. *Completed.* is displayed and the screen returns to the Secure Protocol menu.

HTTP Security

Specify the protocol to be used for HTTP. The default setting is *HTTPS only*.

Use the procedure below to make the setting.

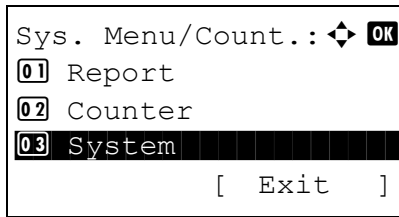

- 1 In the Sys. Menu/Count. menu, press the Δ or ∇ key to select [System], and press the **OK** key.

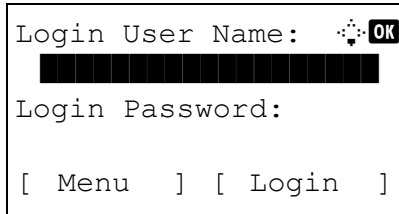

When you are performing user management and have not logged in, a login screen will appear. Then, enter the user ID and password to log in, and press [Login] (the **Right Select** key).

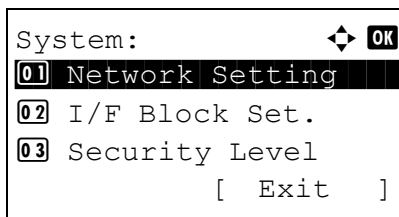

- 2 The System menu appears.

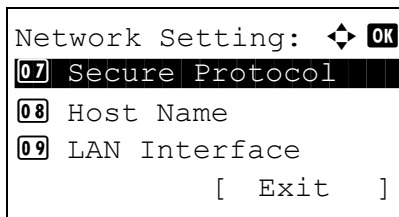

- 3 Press the Δ or ∇ key to select [Network Setting].
- 4 Press the **OK** key. The Network Setting menu appears.

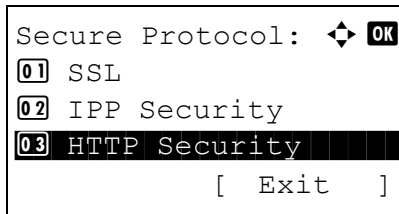

- 5 Press the Δ or ∇ key to select [Secure Protocol].
- 6 Press the **OK** key. Secure Protocol appears.

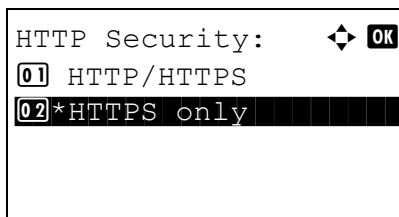

- 7 Press the Δ or ∇ key to select [HTTP Security].
- 8 Press the **OK** key. HTTP Security appears.

- 9 Press the Δ or ∇ key to select [HTTP/HTTPS] or [HTTPS only].
- 10 Press the **OK** key. *Completed.* is displayed and the screen returns to the Secure Protocol menu.

LDAP Security

Specify the protocol to be used for LDAP. The default setting is *Off*.

Use the procedure below to make the setting.

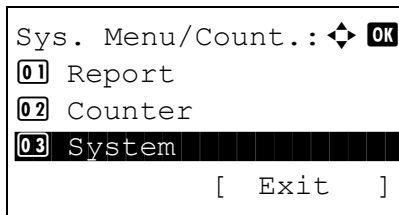

- 1 In the Sys. Menu/Count. menu, press the Δ or ∇ key to select [System], and press the **OK** key.

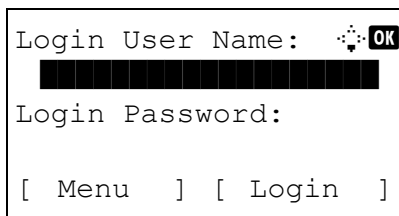

When you are performing user management and have not logged in, a login screen will appear. Then, enter the user ID and password to log in, and press [Login] (the **Right Select** key).

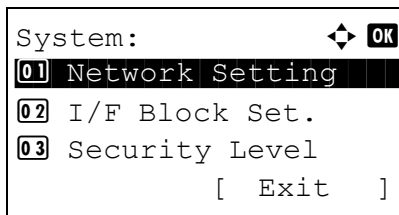

- 2 The System menu appears.

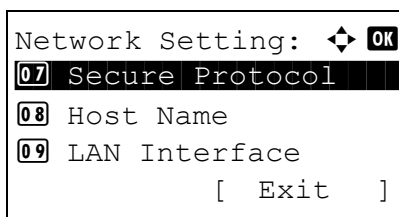

- 3 Press the Δ or ∇ key to select [Network Setting].
- 4 Press the **OK** key. The Network Setting menu appears.
- 5 Press the Δ or ∇ key to select [Secure Protocol].

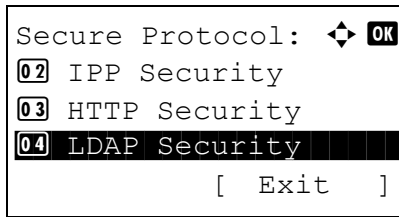

6 Press the **OK** key. Secure Protocol appears.

7 Press the Δ or ∇ key to select [LDAP Security].

8 Press the **OK** key. LDAP Security appears.

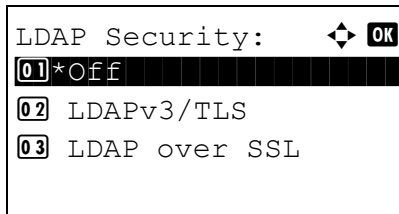

9 Press the Δ or ∇ key to select [Off], [LDAPv3/TLS] or [LDAP over SSL].

10 Press the **OK** key. *Completed.* is displayed and the screen returns to the Secure Protocol menu.

SNMPv3 Setting

Sets up SNMPv3. The default setting is *Off*. Use the procedure below.

Refer to *Protocol Detail on page 8-135* about the procedures.

IPSec Setting

Make this setting when you use IPSec. The default setting is *On* and that of Rule Setting is also *Off*.

Use the procedure below to make the setting.

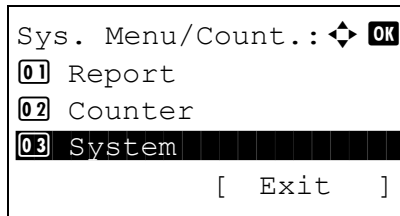

- 1 In the Sys. Menu/Count. menu, press the Δ or ∇ key to select [System], and press the **OK** key.

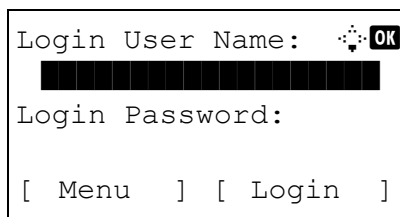

When you are performing user management and have not logged in, a login screen will appear. Then, enter the user ID and password to log in, and press [Login] (the **Right Select** key).

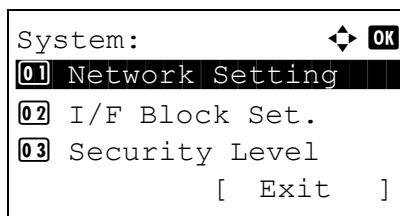

- 2 The System menu appears.

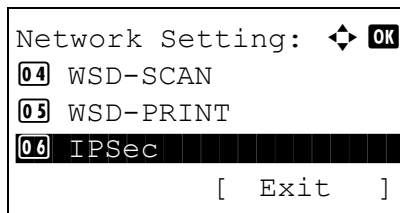

- 3 Press the Δ or ∇ key to select [Network Setting].
- 4 Press the **OK** key. The Network Setting menu appears.

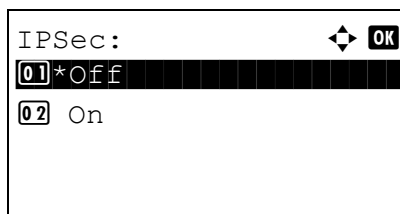

- 5 Press the Δ or ∇ key to select [IPSec].

- 6 Press the **OK** key. IPSec appears.

- 7 Press the Δ or ∇ key to select [On] or [Off].

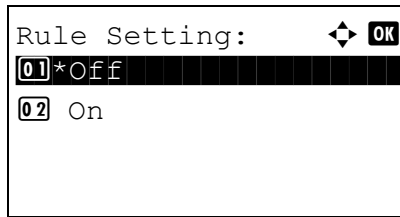

If you select [On] and press the **OK** key, Rule Setting appears. Press the Δ or ∇ key to select [On] or [Off].

- 8 Press the **OK** key. *Completed.* is displayed and the screen returns to the Network Setting menu.

Interface Block Setting

This allows you to protect this machine by blocking the interface with external devices such as USB hosts or optional interfaces.

The following interface block settings are available:

- USB Host (USB memory slot setting)
- USB Device (USB interface setting)
- Optional interface (Optional interface card setting)

USB Host (USB memory slot setting)

This locks and protects the USB memory slot (A1) or USB port (A2) (USB host). The default setting is *Unblock*.

Use the procedure below to specify the USB Host setting.

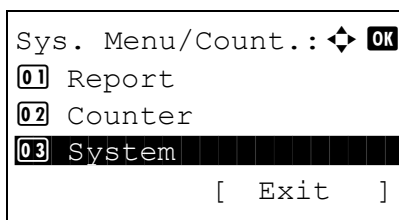

- 1 In the Sys. Menu/Count. menu, press the Δ or ∇ key to select [System], and press the **OK** key.

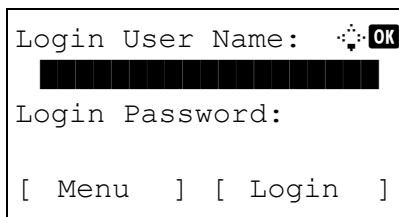

When you are performing user management and have not logged in, a login screen will appear. Then, enter the user ID and password to log in, and press [Login] (the **Right Select** key).

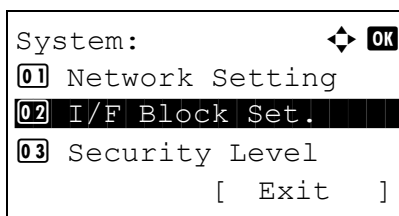

- 2 The System menu appears.

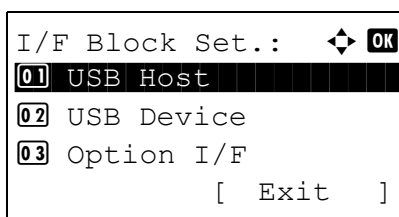

- 3 Press the Δ or ∇ key to select [I/F Block Set.].
- 4 Press the **OK** key. The I/F Block Set. menu appears.

- 5 Press the Δ or ∇ key to select [USB Host].

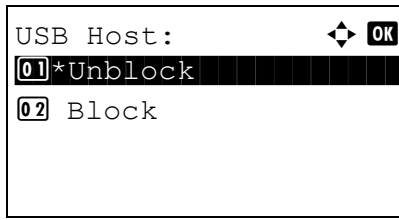

6 Press the **OK** key. USB Host appears.

7 Press the Δ or ∇ key to select [Unblock] or [Block].

8 Press the **OK** key. *Completed.* is displayed and the screen returns to the I/F Block Set. menu.

USB Device (USB interface setting)

This locks and protects the USB interface connector (B1) (USB Device). The default setting is *Unblock*.

Use the procedure below to specify the USB Device setting.

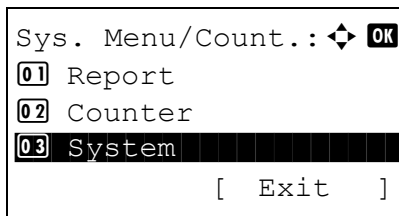

1 In the Sys. Menu/Count. menu, press the Δ or ∇ key to select [System], and press the **OK** key.

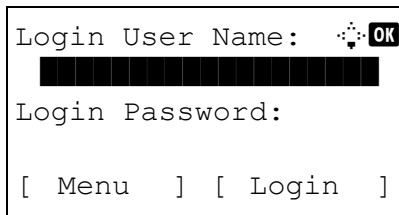

When you are performing user management and have not logged in, a login screen will appear. Then, enter the user ID and password to log in, and press [Login] (the **Right Select** key).

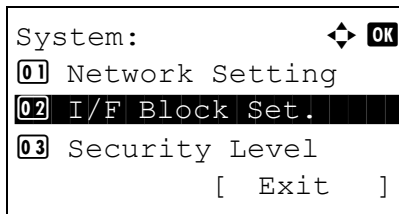

2 The System menu appears.

3 Press the Δ or ∇ key to select [I/F Block Set.].

4 Press the **OK** key. The I/F Block Set. menu appears.

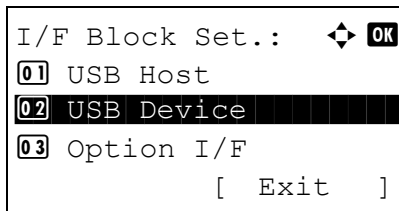

5 Press the Δ or ∇ key to select [USB Device].

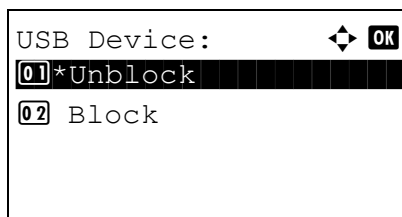

- 6 Press the **OK** key. USB Device appears.
- 7 Press the Δ or ∇ key to select [Unblock] or [Block].
- 8 Press the **OK** key. *Completed.* is displayed and the screen returns to the System menu.

Optional interface (Optional interface card setting)

This locks and protects the optional interface slots (OPT1). The default setting is *Unblock*.

Use the procedure below to specify the optional interface setting.

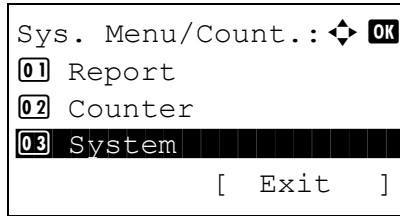

- 1 In the Sys. Menu/Count. menu, press the Δ or ∇ key to select [System].

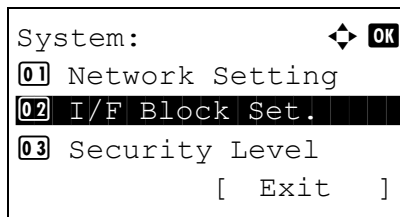

- 2 Press the **OK** key. The System menu appears.

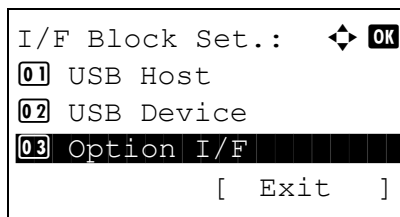

- 3 Press the Δ or ∇ key to select [I/F Block Set.].

- 4 Press the **OK** key. The I/F Block Set. menu appears.

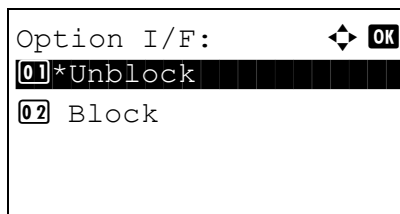

- 5 Press the Δ or ∇ key to select [Option I/F].

- 6 Press the **OK** key. Option I/F appears.

- 7 Press the Δ or ∇ key to select [Unblock] or [Block].

- 8 Press the **OK** key. *Completed.* is displayed and the screen returns to the System menu.

Security Level (Security Level setting)

The Security Level setting is primarily a menu option used by service personnel for maintenance work. There is no need for customers to use this menu.

Optional Functions

You can use the optional applications installed on this machine.

Op Functions

Although nothing is currently displayed, when the optional functions that will be released in the future is installed, the licenses can be set using this menu.

9 Maintenance

This chapter describes cleaning and toner replacement.

- Cleaning.....9-2
- Toner Container9-5

Cleaning

Clean the machine regularly to ensure optimum output quality.

CAUTION: For safety, always unplug the power cord before cleaning the machine.

Glass Platen

Wipe the inside of the document processor and the glass platen with a soft cloth dampened with alcohol or mild detergent.

IMPORTANT: Do not use thinner or other organic solvents.

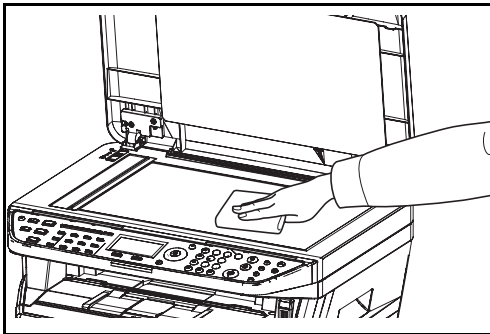

Cleaning the Machine

To avoid print quality problems, the interior of the machine must be cleaned with every toner container replacement.

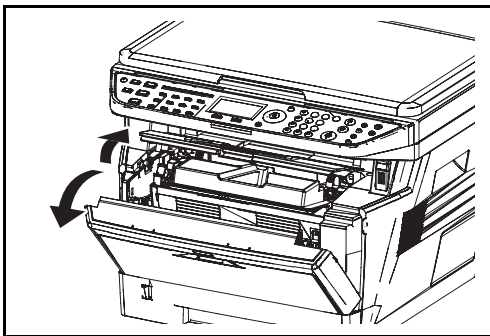

- 1 Open the front cover.

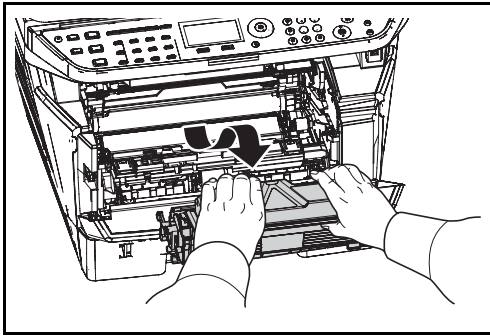

- 2 Lift the developer unit together with the toner container out of the machine.

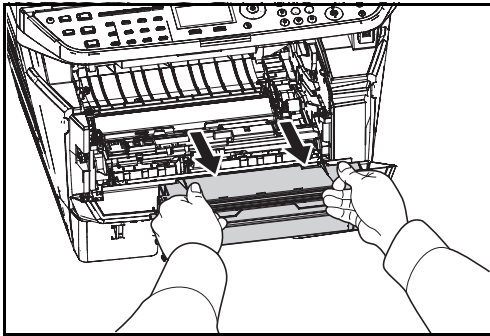

- 3 Remove the drum unit from the machine by holding the green levers with both hands.

NOTE: The drum unit is sensitive to light. Never expose the drum unit to light for more than five minutes.

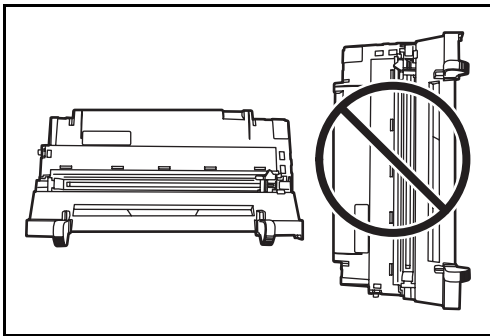

- 4 Place the drum unit flat on a clean, level surface.

IMPORTANT: Do not place the drum unit on end.

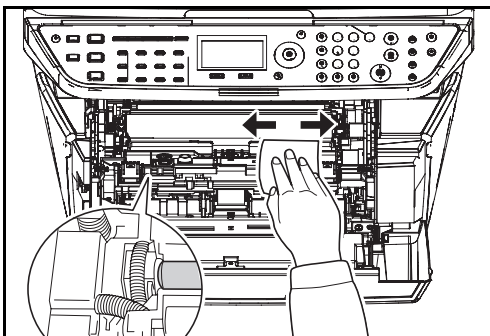

- 5 Use a clean, lint free cloth to clean dust and dirt away from the metal registration roller.

IMPORTANT: Take care not to touch the transfer roller (black) during cleaning.

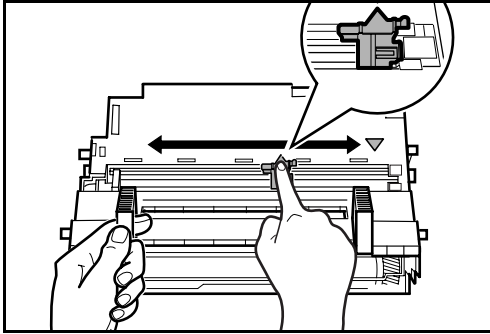

- 6 On the drum unit, slide the main charger cleaner (green) back and forth 2 or 3 times to clean the charger wire, then return it to its original position (CLEANER HOME POSITION).

IMPORTANT: Remove the fixing tape on the main charger cleaner before cleaning for the first time. After cleaning, make sure you restore the main charger cleaner to its home position.

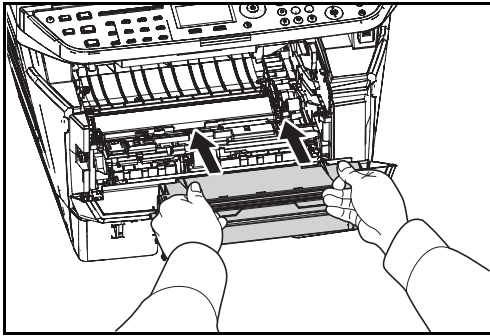

- 7 When cleaning is complete, return the drum unit to the original position.

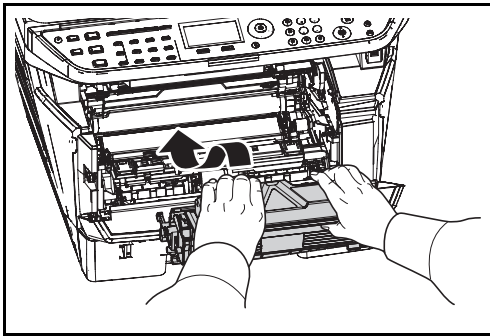

- 8 Return the developer unit to its position, aligning the guides at both ends with the slots in the machine. Then, close the front cover.

Toner Container

When the message display displays *Add toner*, replace the toner.

Every time you replace the toner container, be sure to clean the parts as instructed below. Dirty parts may deteriorate output quality.

CAUTION: Do not attempt to incinerate the toner container or the waste toner box. Dangerous sparks may cause burns.

Toner Container Replacement

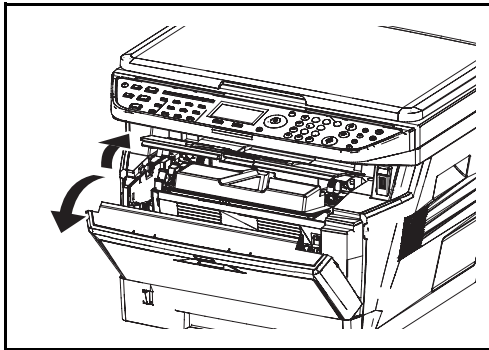

- 1 Open the front cover.

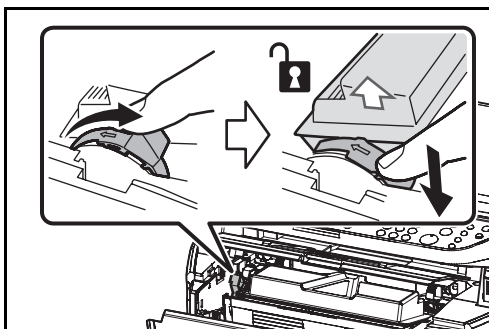

- 2 Turn the lock lever to the unlock position. Push the lock lever to the position marked by the arrow and pull out the toner container.

NOTE: Put the old toner container in the plastic bag (supplied with the new toner kit) and discard it later according to the local code or regulations for waste disposal.

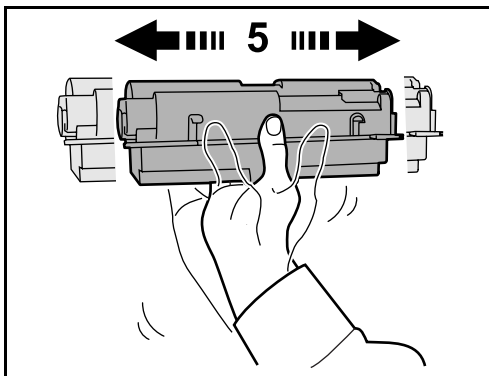

- 3 Take the new toner container out of the toner kit. Shake the new toner container at least 5 times as shown in the figure in order to distribute the toner evenly inside the container.

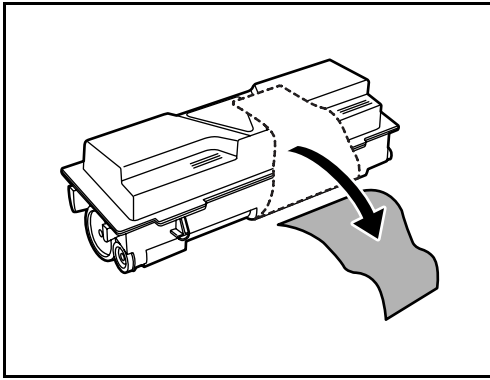

- 4** Remove the label from the toner container.

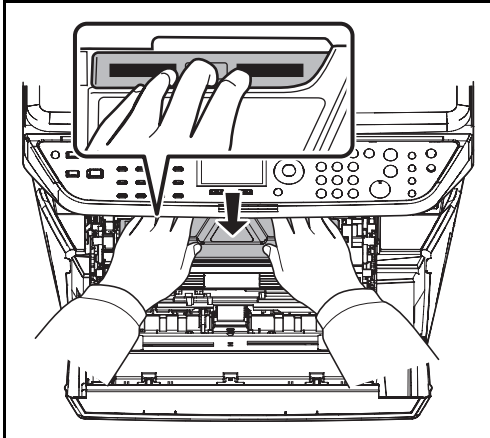

- 5** Install the new toner container in the machine. Push firmly on the top of the container at the positions marked PUSH, until you hear a click.

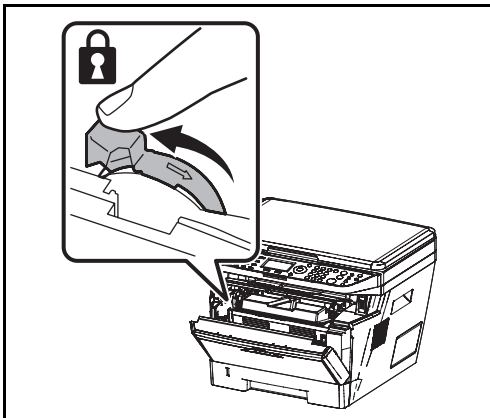

- 6** Turn the lock lever to the lock position.

- 7** Close the front cover.

Prolonged Non-Use and Moving of the Machine

Prolonged Non-use

If you ever leave the machine unused for a long period of time, remove the power cord from the wall outlet.

We recommend you consult with your dealer about the additional actions you should take to avoid possible damage that may occur when the machine is used next time.

Moving the Machine

When you move the machine:

- Move it gently.
- Keep it as level as possible to avoid spilling toner inside the machine.
- Be sure to consult a service technician before attempting long distance transportation of the machine.

WARNING: If you ship the machine, remove and pack the developer unit and drum unit in a plastic bag and ship them separately from the machine.

10 Troubleshooting

This chapter explains how to solve problems with the machine.

- Solving Malfunctions 10-2
- Responding to Error Messages 10-5
- Clearing Paper Jams 10-11

Solving Malfunctions

The table below provides general guidelines for problem solving.

If a problem occurs with your machine, look into the checkpoints and perform procedures indicated on the following pages. If the problem persists, contact your Service Representative.

Symptom	Checkpoints	Corrective Actions	Reference Page
The operation panel does not respond when the main power switch is turned on.	Is the machine plugged in?	Plug the power cord into an AC outlet.	—
Pressing the Start key does not produce copies.	Is there a message on the Message Display?	Determine appropriate response to the message and respond accordingly.	—
	Is the machine in Sleep mode?	Press the Power key to recover the machine from Sleep mode. The machine will be ready to copy within 45 seconds.	3-5
Blank sheets are ejected.	Are the originals loaded correctly?	When placing originals on the platen, place them face-down and align them with the original size indicator plates.	2-44
		When placing originals in the optional document processor, place them face-up.	2-46
Printouts are too light.	Is the machine in Auto Density mode?	Set the correct density level for auto density.	—
	Is the machine in Manual Density mode?	Select the correct density level.	5-13
		When changing the default density level, adjust the density manually and choose the desired level.	—
	Is the toner distributed evenly within the toner container?	Shake the toner container from side to side about several times.	9-5
	Is there a message indicating the addition of toner?	Replace the toner container.	9-5
	Is the paper damp?	Replace the paper with new paper.	2-28
	Is EcoPrint mode enabled?	Disable EcoPrint mode.	4-10
Printouts are too dark.	Is the machine in Auto Density mode?	Set the correct density level for auto density.	—
	Is the machine in Manual Density mode?	Select the correct density level.	5-13
		When changing the default density level, adjust the density manually and choose the desired level.	—

Symptom	Checkpoints	Corrective Actions	Reference Page
Copies have a moire pattern (dots grouped together in patterns and not aligned uniformly).	Is the original a printed photograph?	Set the image quality to [Photo].	5-12
Printouts are not clear.	Did you choose appropriate image quality for the original?	Select appropriate image quality.	5-12
Printouts are dirty.	Is the platen or the document processor dirty?	Clean the platen or the document processor.	—
	Is the charger wire dirty?	Clean the charger wire.	—
Printouts are fuzzy.	Is the machine being used in very humid conditions?	Clean the charger wire.	—
Images are skewed.	Are the originals placed correctly?	When placing originals on the platen, align them with the original size indicator plates.	2-44
		When placing originals in the optional document processor, align the original width guides securely before placing the originals.	2-45
	Is the paper loaded correctly?	Check the position of the paper width guides.	2-45
Paper often jams.	Is the paper loaded correctly?	Load the paper correctly.	2-28
	Is the paper of the supported type? Is it in good condition?	Remove the paper, turn it over, and reload it.	2-28
	Is the paper curled, folded or wrinkled?	Replace the paper with new paper.	2-28
	Are there any loose scraps or jammed paper in the machine?	Remove any jammed paper.	10-11
Printouts are wrinkled.	Is the paper damp?	Replace the paper with new paper.	2-28
	Is the paper set in a proper orientation?	Change the orientation in which the paper is positioned.	—

Symptom	Checkpoints	Corrective Actions	Reference Page
Cannot print.	Is the machine plugged in?	Plug the power cord into an AC outlet.	—
	Is the machine powered on?	Turn on the main power switch.	3-2
	Is the printer cable connected?	Connect the correct printer cable securely.	2-5
	Was the machine powered on before the printer cable was connected?	Power on the machine after connecting the printer cable.	2-5 3-2
	Is the print job paused?	Press [Resume] to resume printing.	7-19
Documents are printed improperly.	Are the application software settings at the PC set properly?	Check that the printer driver and application software settings are set properly.	—
While the operation panel was being used, the keys locked up and do not respond when pressed.	Is the operation panel locked?	Check the panel lock setting in COMMAND CENTER and change the setting if necessary.	KYOCERA COMMAND CENTER Operation Guide
Cannot print with USB memory.	Was the USB memory formatted with a machine other than this machine?	Format the USB memory with this machine.	
	Is the USB host blocked?	Select <i>Unblock</i> in the USB host settings.	8-146
	Check that the USB memory is securely plugged into the machine.	—	—
When displaying an image sent from the machine on the PC, an image size is shrunk vertically or horizontally.	Have you selected 200×100dpi Normal or 200×400dpi Super Fine for the scan resolution?	Select a scan resolution other than 200×100dpi Normal or 200×400dpi Super Fine when sending an image.	5-14
USB memory not recognized.	Check that the USB memory is securely plugged into the machine.	—	—
	Is the USB host blocked?	Select <i>Unblock</i> in the USB host settings.	8-146
Vertical streaks appear on prints.	The inside of the machine may be dirty.	Check the toner container and if necessary replace.	9-5
		Clean the charger wire.	—
		Check the main charger cleaner of the drum unit is in its original position.	—

Responding to Error Messages

If the control panel displays any of these messages, follow the corresponding procedure.

Alphanumeric

Error Message	Checkpoints	Corrective Actions	Reference Page
Load paper in cassette 1.	Is the indicated cassette out of paper?	Load paper.	2-29
Load paper in MP Tray.	Is the paper of the selected size loaded in the multi purpose tray?	Load the paper in the multi purpose tray which is of the size and type indicated on the Message Display.	2-32
Add toner.	–	Replace the toner container.	9-5
Cannot connect to Authentication Server.	–	Press the OK key and check the following items: <ul style="list-style-type: none"> • Registration to Authentication Serve • Password and computer address for Authentication Server • Connection of Network 	—
Cannot duplex print on this paper.	Did you select a paper size/ media type that cannot be duplex printed?	Select the available paper type. Press the OK key to print without using Duplex.	3-14
Incorrect account ID. Job is canceled.	–	This job is canceled because it is restricted by Job Accounting. Press the OK key.	—
Close front cover.	Is there any cover which is open?	Close the cover indicated on the control panel.	—
Close Document Processor.	Is the document processor open?	Close the document processor.	—
	Is the top cover of the document processor open?	Close the top cover of the document processor.	2-45
Job Accounting restriction exceeded. Cannot print.	–	The job is canceled. Press the OK key.	—
Job Accounting restriction exceeded. Cannot scan.	–	The job is canceled. Press the OK key.	—
Sub address/Polling box limit exceeded. Job is canceled.	–	FAX box is full, and no further storage is available. The job is canceled. Press the OK key.	—

Error Message	Checkpoints	Corrective Actions	Reference Page
Incorrect Login User Name or Password. Job is canceled.	–	Enter correct login user name or password.	—
Job Accounting restriction exceeded. Job is canceled.	Is the acceptable printing count restricted by Job Accounting exceeded?	The printing count exceeded the acceptable count restricted by Job Accounting. Cannot print any more. This job is canceled. Press the OK key.	—
Machine failure. Call service.	–	Internal error has occurred. Make a note of the error code displayed on the Message Display. Turn off the machine, unplug the power cord, and contact your Service Representative.	—
	Is Error code "C4200" displayed?	Internal condensation has occurred as a result of a sudden change in temperature. Turn off the machine and let stand for 30 to 90 minutes, and then back on again. If this message still remains, turn off the machine, unplug the power cord, and contact your Service Representative.	—
Memory is full. Print job cannot be processed completely.	–	Unable to continue the job as the memory is used up. Press the OK key to print the scanned pages. The print job cannot be processed completely. Press the STOP key to cancel the job.	—
Paper jammed.	–	If a paper jam occurs, the machine will stop and the location of the jam will be indicated on the Message Display. Leave the machine on and follow the instruction to remove the jammed paper.	10-11
USB memory error. Job is canceled.	–	This job is canceled. Press the OK key.	—
Place original and press Start key.	–	Remove originals from the document processor, put them back in their original order, and place them again. Press the Start key to resume printing. Press the STOP key to cancel the job.	2-46
Remove original from document processor.	Are there any originals left in the document processor?	Remove originals from the document processor.	—

Error Message	Checkpoints	Corrective Actions	Reference Page
Scanner memory is full. Job is canceled.	—	Scanning cannot be performed due to insufficient memory of scanner. The job is canceled. Press the OK key.	—
	Is the acceptable scanning count exceeded?	Press the OK key to print, send or store the scanned pages. Press the STOP key to cancel printing, sending or storing.	—
Send error. ####	—	An error has occurred during transmission. The possible error codes and their descriptions are as follows. 1101: The server name of the SMTP server is not set correctly or the host name is incorrect when sending scan data to an FTP server. Use COMMAND CENTER and register the SMTP server name and the host name correctly. 1102: The login user name is incorrect or the domain name has not been entered. Enter login user name, domain name and password correctly. 1103: The network path name is incorrect or you do not have access to the folder specified. Use COMMAND CENTER and register the path name correctly. 1104: No recipient address. Enter E-mail address correctly.	—

Error Message	Checkpoints	Corrective Actions	Reference Page
<p>Send error.####</p>	<p>—</p>	<p>1105: E-mail - The SMTP protocol setting is turned off. Use COMMAND CENTER and turn on the SMTP protocol setting. Scan to PC (SMB) - SMB setting is turned off. Use COMMAND CENTER and turn on the SMB setting. Scan to PC (FTP) - FTP setting is turned off. Use COMMAND CENTER and turn on the FTP setting. 1106: The sender address setting under E-mail: SMTP is not registered. Use COMMAND CENTER and register the sender address. 2101, 2102, 2103, 2201, 2202, 2203, 3101: The network cable is disconnected or the hub that it is connected to is not operating properly. Check the cable and the hub. Otherwise, the server name or the host name of the SMTP server is not set correctly. Use COMMAND CENTER and register the SMTP server name and the host name correctly. 2204: The E-mail size exceeds the acceptable send data capacity. Decrease the size or resolution of the scanned data to be transmitted and resend the E-mail. 5101, 5102, 5103, 5104, 7102, 720f: Turn the main power switch off and back on. If this error occurs several times, make a note of the displayed error code and contact your service representative. (Refer to the corrective action for the error message “ An error has occurred.”) 9181: The scanned original exceeds the acceptable number of pages of 999. Send the excess pages separately.</p>	<p>— — —</p>
<p>Error occurred. Turn the main power switch off and on.</p>	<p>—</p>	<p>System error has occurred. Turn the main power switch off and on.</p>	<p>—</p>
<p>Incorrect account ID.</p>	<p>—</p>	<p>The Account ID does not match. Check the registered Account ID.</p>	<p>—</p>

Error Message	Checkpoints	Corrective Actions	Reference Page
The phone receiver is off the hook. Hang Up.	–	Put down the receiver.	—
File is not found. Job is canceled.	–	The specified file is not found. The job is canceled. Press the OK key.	—
Top tray is full of Paper. Remove the paper.	–	Remove paper from the top tray, and press the OK key to resume the job.	—
Unknown toner Installed.	–	If the toner container was taken from a different machine of the same model while it was displaying the <i>Add toner.</i> message, ignore the message and use the toner.	—
Unknown toner Installed. PC	–	This message is displayed if the installed toner container's regional specification does not match the machine's.	—
Insufficient memory. Cannot start the job	–	Further scanning cannot be performed due to insufficient memory. Press the OK key to print the scanned pages. Press the Cancel key to cancel the printing job.	—

Responding to an Error Lamp Flashes

If an error lamp flashes, press [Status/Job Cancel] to check an error message. If the message is not indicated on the Message Display when [Status/Job Cancel] is pressed or the error lamp flashes for 1.5 seconds, check the following.

Symptom	Checkpoints	Corrective Actions	Reference Page
Cannot send fax.	Is the modular cord connected correctly?	Connect the modular cord correctly.	—
	Is Permitted FAX No. or Permitted ID No. registered correctly?	Check Permitted FAX No. and Permitted ID No..	<i>FAX Operation Guide</i> Chapter 6 "Registering Permit FAX No." and "Registering Permit ID No."
	Has a communication error occurred?	Check error codes in the TX/RX Result Report and Activity Report. If the error code starts with "U" or "E", perform the corresponding procedure.	<i>FAX Operation Guide</i> Appendix "Error Code List"
	Is the destination FAX line busy?	Send again.	—
	Does the destination FAX machine respond?	Send again.	—
	Is there an error other than above?	Contact your Service Representative.	—

Clearing Paper Jams

If a paper jam occurs, a message will be displayed about the jam and copying or printing will stop.

Leave the main power switch on and to remove the jammed paper refer to the following information below.

Jam Location Indicators

If a paper jam occurs, the error message displays the location of the jam.

Paper Jam Location Indicator	Paper Jam Location	Reference Page
	Document processor (Option)	10-16
	Inside the machine	10-14
	MP Tray	10-11
	Cassettes	10-12
	Duplexer	10-12
	Rear cover	10-15

Precautions with Paper Jams

If a paper jam occurs, a message will be displayed about the jam and copying or printing will stop.

- Do not reuse jammed papers.
- If the paper tears during removal, be sure to remove any loose scraps of paper from inside the machine. Scraps of paper left in the machine could cause subsequent jamming.
- Discard paper that has jammed in the optional document finisher. A page affected by a paper jam will be printed again.

CAUTION: The fixing unit is extremely hot. Take sufficient care when working in this area, as there is a danger of getting burned.

Online Help Messages

When Paper Jam is displayed, press [Help](the **Left Select** key) to display the procedure to clear the jam.

Press ∇ to display the next step or press \triangle to display the previous step.

Press the **OK** key to exit the online help message display.

Multi Purpose Tray

Follow the steps below to clear paper jams in the MP tray.

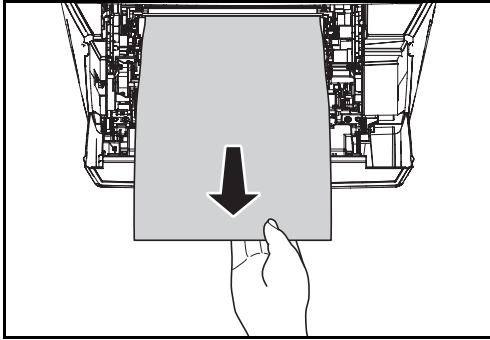

- 1 Remove the paper jammed at the MP tray.

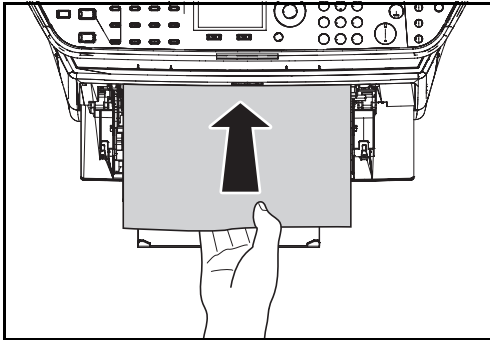

- 2 Reload the MP tray. Open and close the top cover to clear the error and the machine warms up and resumes printing.

Paper Cassette/Paper Feeder

Follow the steps below to clear paper jams in paper cassette or paper feeder.

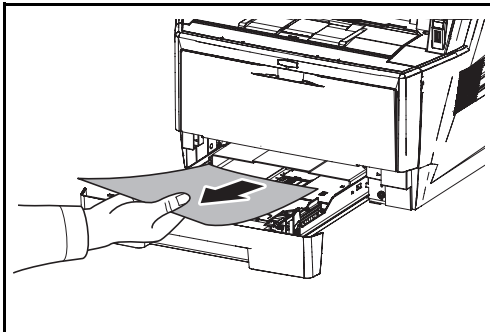

- 1 Pull out the cassette or optional paper feeder.
- 2 Remove any partially fed paper.

IMPORTANT: Do not try to remove paper that has already been partially fed. Proceed to *Inside the Machine* on page 10-14.

NOTE: Check to see if paper is loaded correctly. If not, reload the paper.

- 3 Push the cassette back in securely. The machine warms up and resumes printing.

Duplexer

Paper is jammed in the duplexer. Remove the jammed paper using the procedure given below.

- 1 Pull the paper cassette all the way out of the machine.

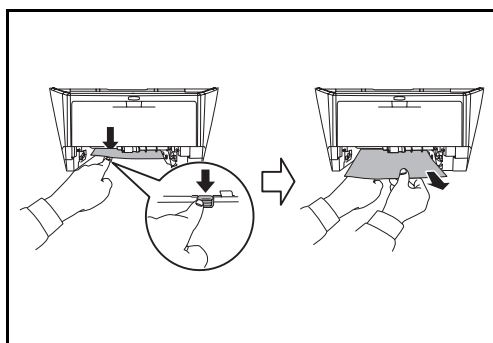

- 2** Open the duplexer's cover in front of the machine and remove any jammed paper.

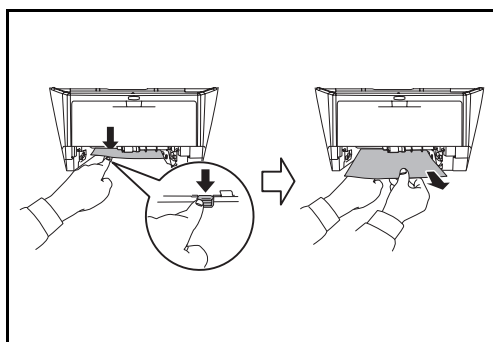

Open the duplexer's cover at the rear of the machine and remove any jammed paper.

- 3** Push the cassette back in securely, and open and close the top cover to clear the error. The machine warms up and resumes printing.

Inside the Machine

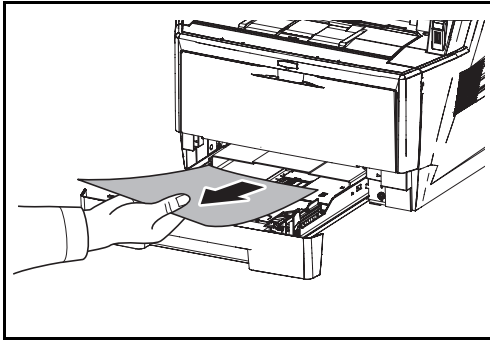

- 1 Pull the paper cassette all the way out of the machine. Remove any partially fed paper.

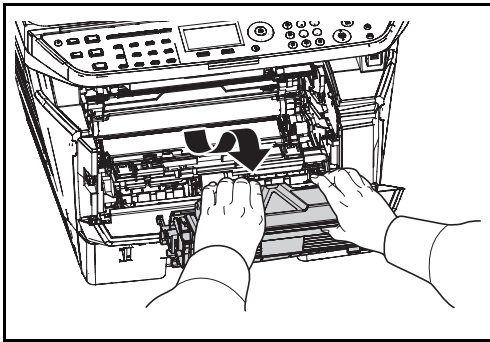

- 2 Open the front cover, and lift the developer unit together with the toner container out of the machine.

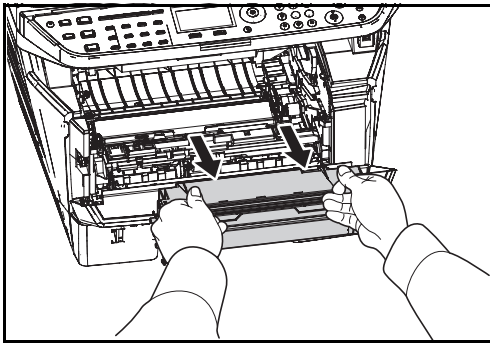

- 3 Remove the drum unit from the machine by holding the green levers with both hands.

CAUTION: The fuser unit inside the machine is hot. Do not touch it, as it may result in burn injury.

NOTE: The drum is sensitive to light. Never expose the drum unit to light for more than five minutes.

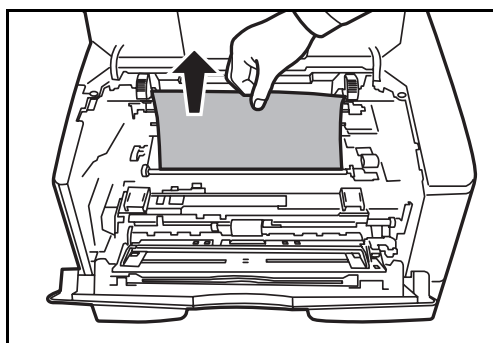

- 4 If the jammed paper appears to be pinched by rollers, pull it along the normal running direction of the paper.

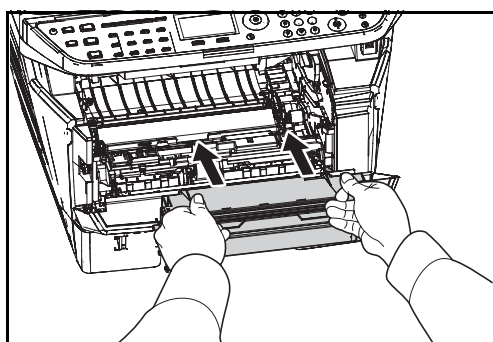

- 5 Return the drum unit to its position, aligning the guides at both ends with the slots in the machine.

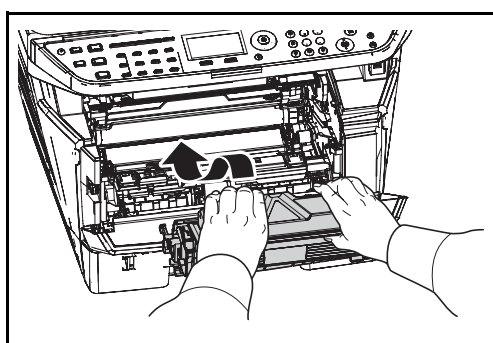

- 6 Insert the developer unit together with the toner container, back into the machine. Close the front cover. The machine warms up and resumes printing.

Rear Cover

Follow the steps below to clear paper jams of the rear cover.

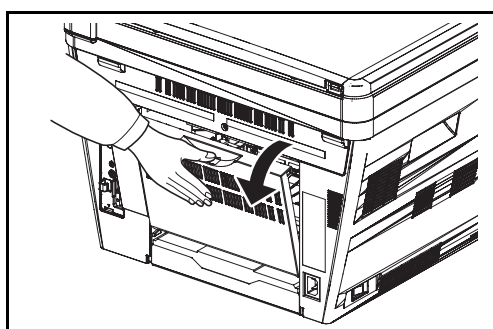

- 1 Open the rear cover and remove the jammed paper by pulling it out.

CAUTION: The fuser unit inside the machine is hot. Do not touch it, as it may result in burn injury.

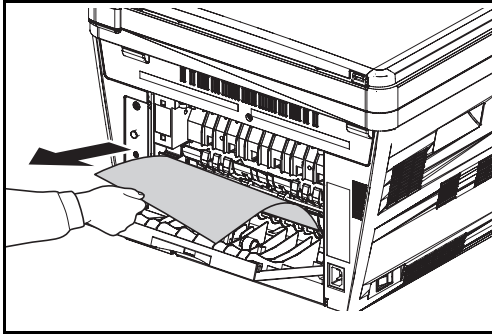

If the paper is jammed inside the fuser unit, open the fuser cover and remove the paper by pulling it out.

- 2 Close the rear cover, and open and close the top cover to clear the error. The machine warms up and resumes printing.

Optional Document Processor

Follow the steps below to clear paper jams in the optional document processor.

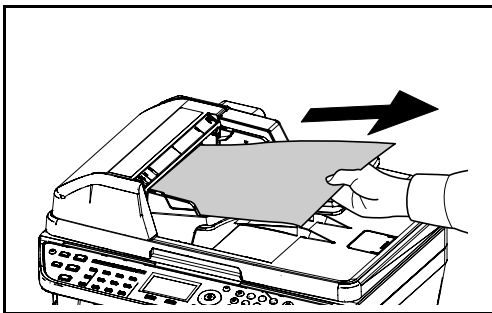

- 1 Remove all of the originals from the document feed tray.

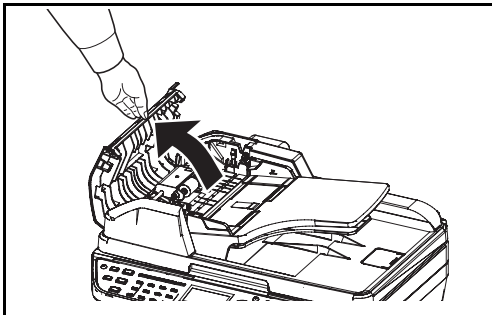

- 2 Open the left cover of the document processor.

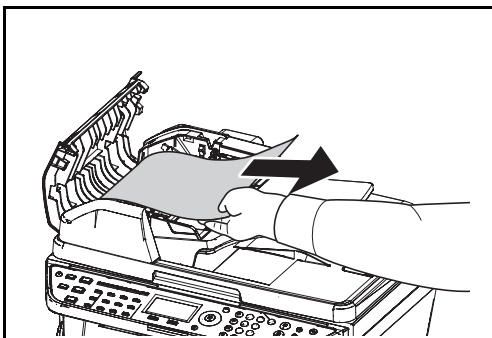

- 3 Remove the jammed original.

If the original is caught in the rollers or difficult to remove, proceed to the next step.

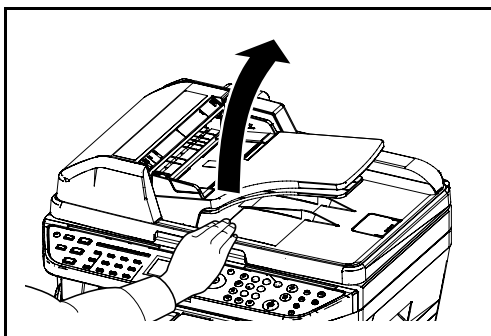

4 Open the document processor.

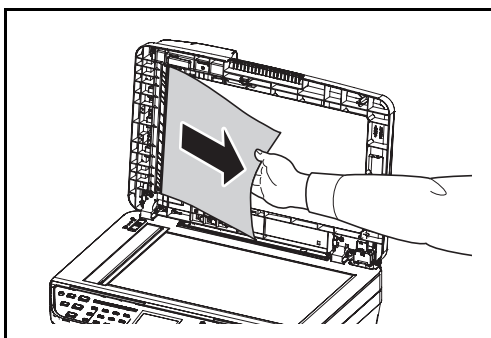

5 Remove the jammed original.

If the original tears, remove every loose scrap from inside the machine.

6 Close the document processor.

7 Place the originals.

11 Management

This chapter explains the following operations.

- User Login Administration 11-2
- Job Accounting 11-13
- Checking the Counter 11-37

User Login Administration

User login administration specifies how the user access is administered on this machine. Enter correct login user name and password for user authentication to log in.

Access are in three levels - User, Administrator, and Machine Administrator. The security levels can be modified only by the machine administrator.

First User Login Administration

Follow these steps for the first user login administration.

Enable user login administration. (page 11-2)



Add a user.(page 11-6)



Log out.(page 11-5)



The registered user logs in for operations.(page 11-5)

Enabling/Disabling User Login Administration

This enables user login administration. Select one of the following authentication methods:

Item	Description
Local Authentication	User authentication based on user properties on the local user list stored in the machine.
Network Authentication	User authentication based on Authentication Server. Use a user property stored in Authentication Server to access the network authentication login page.

Use the procedure below to enable user login administration.

NOTE: Refer to *Character Entry Method on Appendix-5* for details on entering characters.

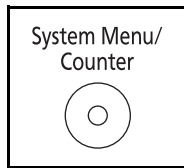

- 1 Press the **System Menu/Counter** key on the main unit operation panel.

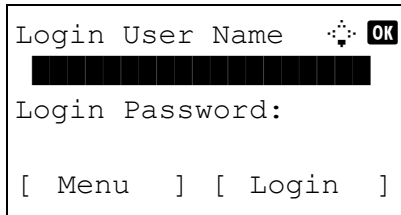

If user login administration is disabled, the user authentication screen appears. Enter your login user name and password and then press [Login]. For this, you need to log in with administrator privileges. Refer to *Adding a User on page 11-6* for the default login user name and password.

NOTE: If [Netwk Authentic.] is selected as the user authentication method, press [Menu] (the **Left Select** key) to select the authentication destination.

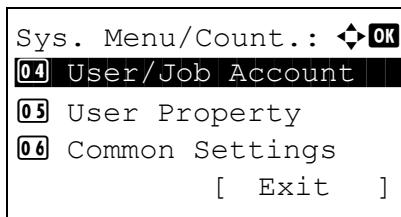

- 2 In the Sys. Menu/Count. menu, press the Δ or ∇ key to select [User/Job Account].

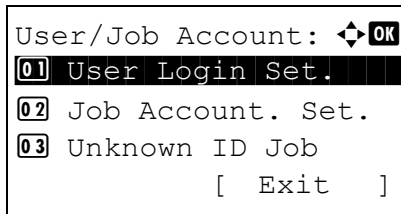

- 3 Press the **OK** key. The User/Job Account menu appears.

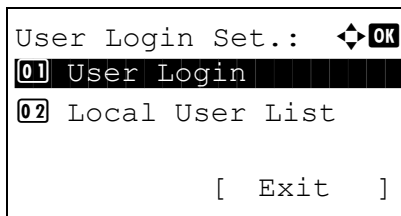

- 4 Press the Δ or ∇ key to select [User Login Set.].

- 5 Press the **OK** key. The User Login Set. menu appears.

- 6 Press the Δ or ∇ key to select [User Login].

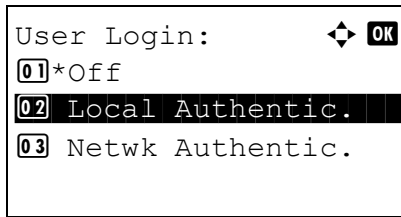

7 Press the **OK** key. User Login appears.

8 Press the Δ or ∇ key to select [Local Authentic.] or [Netwk Authentic.], and then press the **OK** key.

Select [Off] to disable user login administration.

If you select [Netwk Authentic.], enter the host name and domain name of the authentication server (up to 64 and 256 characters, respectively), and then press the **OK** key. Then, select the server type from [NTLM] or [Kerberos] and then press the **OK** key.

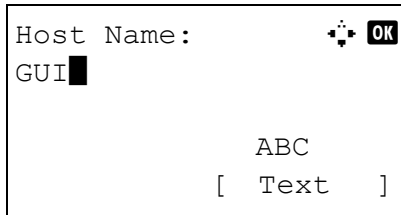

NOTE: If the login user name and password are rejected, check the following settings.

- Network Authentication setting of the machine
- User property of the Authentication Server
- Date and time setting of the machine and the Authentication Server

If you cannot login because of the setting of the machine, login with any administrator registered in the local user list and correct the settings. If the server type is [Kerberos], only domain names entered in uppercase will be recognized.

Completed. is displayed and the screen returns to the User Login Set. menu.

Login/Logout

Once you enable user login administration, a login user name and password entry screen appears each time you use this machine.

Login

Log in using the procedure below.

NOTE: Refer to *Character Entry Method on Appendix-5* for details on entering characters.

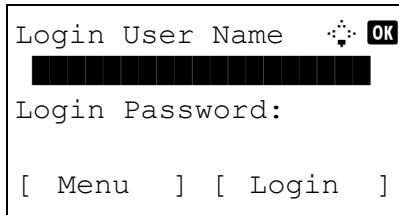

- 1 If the screen below appears during the operations, perform the following login operations.
- 2 Press the **OK** key, enter the login user name, and then press the **OK** key.
- 3 Press the ∇ key to select [Login Password], press the **OK** key, enter the login password, and then press the **OK** key.
- 4 Check the login user name and password are correct, and press [Login] (the **Right Select** key).

NOTE: If [Netwk Authentic.] is selected as the user authentication method, press [Menu] (the **Left Select** key) to select the authentication destination.

Logout

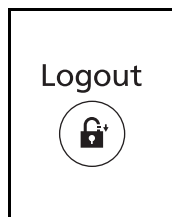

To log out the machine, press the **Logout** key to return to the login user name/login password entry screen.

Auto Logout

Logout is automatically executed in the following cases:

- When the **Power** key is pressed to enter the sleep mode
- When auto sleep is activated
- When auto panel reset is activated
- When auto low power mode is activated

Adding a User

This adds a new user. You can add Up to 21 users (including the default login user name). The table below explains the user information to be registered.

Item	Description
User Name*	Enter the name displayed on the user list (up to 32 characters).
Login User Name*	Enter the login user name to log in (up to 32 characters). The same login user name cannot be registered.
Login Password*	Enter the password to log in (up to 64 characters).
Access Level*	Select Administrator or User for user access privileges.
Account Name	Add an account where the user belongs. The user, who registered his/her account name, can log in without entering the account ID. Refer to <i>Job Accounting on page 11-13</i> .
E-mail Address	The user can register his/her E-mail address. The registered address will be automatically selected for subsequent operations that need any E-mail function.

* Mandatory at user registration.

NOTE: By default, one of each default user with machine administrator rights and administrator privileges is already stored. The following are the default user's properties.

User Name: DeviceAdmin
 Login User Name: 2800
 Login Password: 2800
 Access Level: Administrator

It is recommended to periodically change the user name, login user name and login password regularly for your security.

Use the procedure below to register a new user.

NOTE: Refer to *Character Entry Method on Appendix-5* for details on entering characters.

- 1 Log in as a user with administrator rights.
- 2 Press the **System Menu/Counter** key on the main unit operation panel.

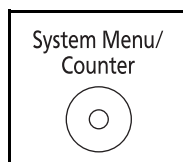

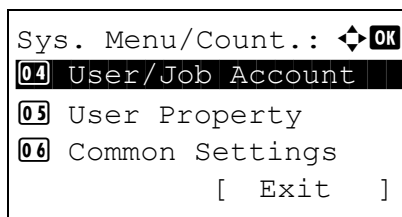

- 3 In the Sys. Menu/Count. menu, press the Δ or ∇ key to select [User/Job Account], and then press the **OK** key.

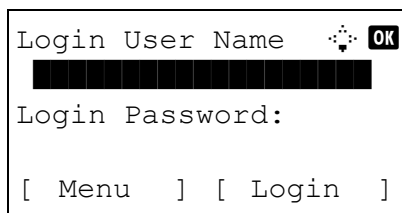

- 4 If user login administration is disabled, the user authentication screen appears. Enter your login user name and password and then press [Login]. For this, you need to log in with administrator privileges. Refer to *Adding a User on page 11-6* for the default login user name and password.

NOTE: If [Netwk Authentic.] is selected as the user authentication method, press [Menu] (the **Left Select** key) to select the authentication destination.

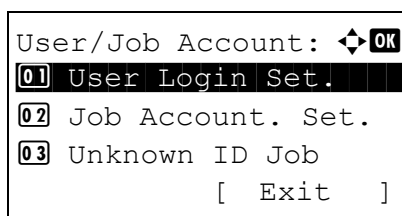

- 5 In the User/Job Account menu, press the Δ or ∇ key to select [User Login Set.].

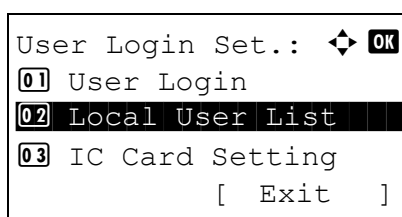

- 6 Press the **OK** key. The User Login Set. menu appears.

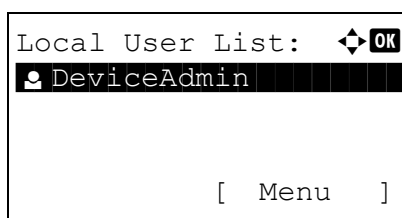

- 7 Press the Δ or ∇ key to select [Local User List].
- 8 Press the **OK** key. Local User List appears.

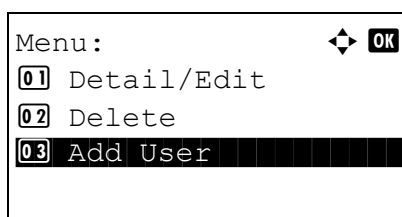

- 9 Press [Menu] (the **Right Select** key), press the Δ or ∇ key to select [Add User], and then press the **OK** key.

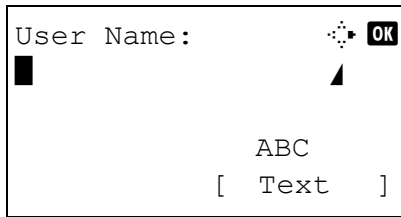

10 Enter the user name and press the **OK** key, enter the login user name in the next screen, and then press the **OK** key.

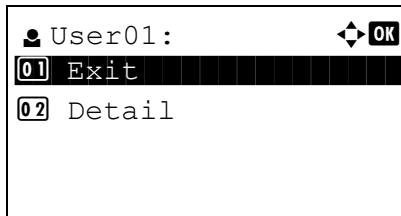

11 Press the Δ or ∇ key to select [Exit] and then press the **OK** key.

Select [Detail] and press the **OK** key to see information of the registered users.

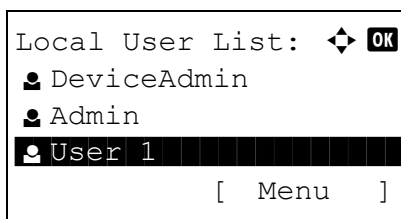

12 In Local User List, press the Δ or ∇ key to select the added user and then press the **OK** key.

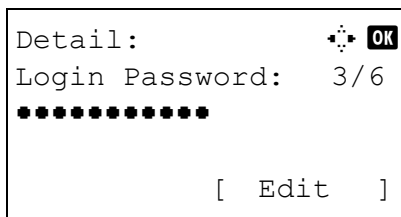

13 Press the \triangleleft or \triangleright key to select [Login Password:], press [Edit] (the **Right Select** key), enter the login password, and then press the **OK** key.

14 Enter the same login password to confirm and press the **OK** key.



15 Press the \triangleright key to select [E-mailAddress:], press [Edit] (the **Right Select** key), enter the e-mail address, and then press the **OK** key.

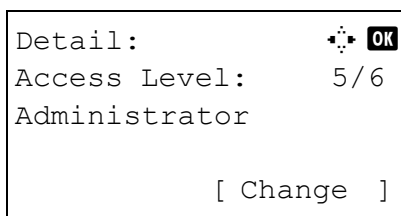

16 Press the \triangleright key to select [Access Level:], press [Change] (the **Right Select** key), select the user access privilege, and then press the **OK** key.

NOTE: If the user list is for device administrator, [Change] is not displayed.

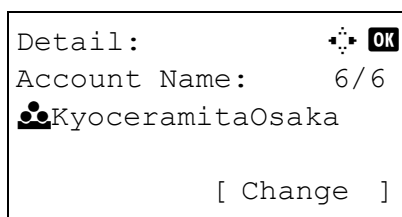

- 17 Press the \triangleright key to select [Account Name:], press [Change] (the **Right Select** key), select the account, and then press the **OK** key.

NOTE: If the user list is for device administrator and the device administrator does not log in, [Change] is not displayed.

- 18 After entering the user information, press the **OK** key again.

Registered. is displayed and the screen returns to Local User List.

Changing User Properties

User information can be changed. It can be changed only by a user with administrator privileges.

Use the procedure below to change the user properties.

NOTE: Refer to *Character Entry Method on Appendix-5* for details on entering characters.

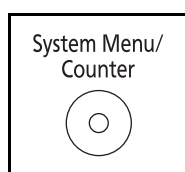

- 1 Press the **System Menu/Counter** key on the main unit operation panel.

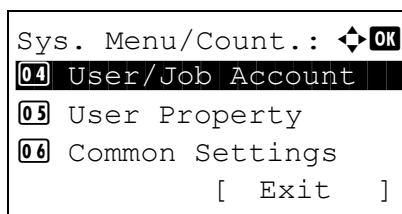

- 2 In the Sys. Menu/Count. menu, press the Δ or ∇ key to select [User/Job Account], and then press the **OK** key.

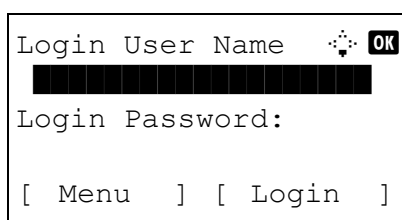

- 3 If user login administration is disabled, the user authentication screen appears. Enter your login user name and password and then press [Login]. For this, you need to log in with administrator privileges. Refer to *Adding a User on page 11-6* for the default login user name and password.

NOTE: If [Netwk Authentic.] is selected as the user authentication method, press [Menu] (the **Left Select** key) to select the authentication destination.

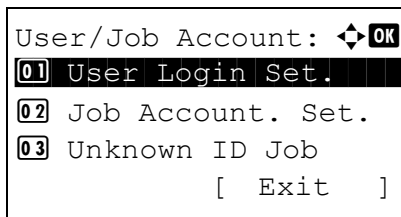

4 In the User/Job Account menu, press the Δ or ∇ key to select [User Login Set.].

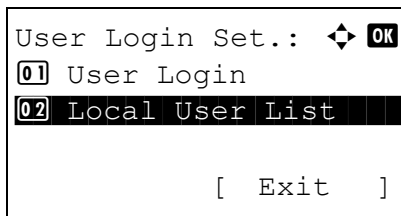

5 Press the **OK** key. The User Login Set. menu appears.

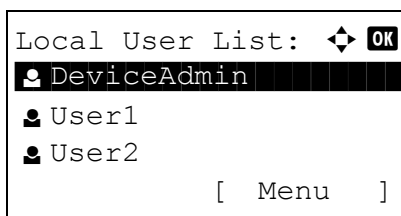

6 Press the Δ or ∇ key to select [Local User List].

7 Press the **OK** key. Local User List appears.

The procedure differs depending on the details to be edited.

Changing user information

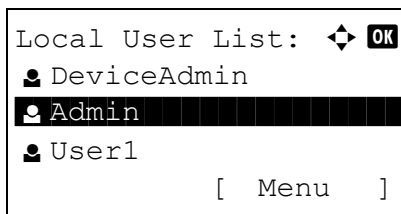

1 Press the Δ or ∇ key to select the user whose information you want to change, and then press the **OK** key.

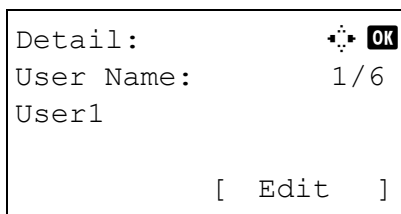

2 In the same fashion as registering a new user, press the \triangleleft or \triangleright key to select the desired item, press [Edit] (the **Right Select** key), change information, and then press the **OK** key.

3 Repeat step 2 to change items as necessary.

4 After completing changing the user information, press the **OK** key again.

- 5 The overwrite confirmation screen appears.
Press [Yes] (the **Left Select** key). The user information is changed and the screen returns to Local User List.

Deleting a user

- 1 Press the Δ or ∇ key to select the user you want to delete, and then press [Menu] (the **Right Select** key).
- 2 Press the Δ or ∇ key to select [Delete] and then press the **OK** key.
- 3 In the delete confirmation screen, press [Yes] (the **Left Select** key). The user is deleted and the screen returns to Local User List.

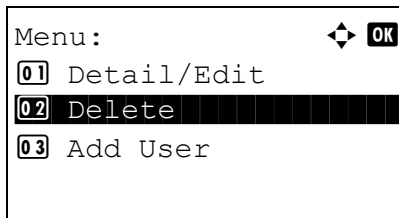
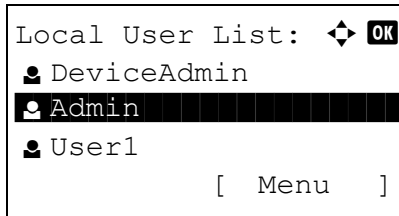

Unknown login user name Job

This specifies the behavior for handling the jobs sent with unknown login user names or User ID (i.e. unsent IDs). If the User Login is set to invalid and Job Accounting is set to valid, follow the procedure when the Account ID is unknown.

The table below shows the available settings.

Item	Description
Reject	The job is rejected (not printed).
Permit	The job is permitted to be printed.

Use the procedure below to process jobs sent from unknown users.

NOTE: Refer to *Character Entry Method on Appendix-5* for details on entering characters.

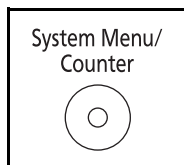

1 Press the **System Menu/Counter** key on the main unit operation panel.

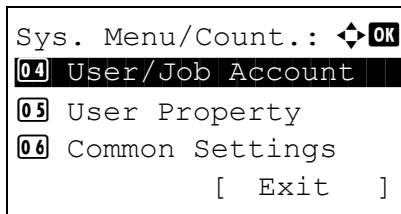

2 In the Sys. Menu/Count. menu, press the Δ or ∇ key to select [User/Job Account], and then press the **OK** key.

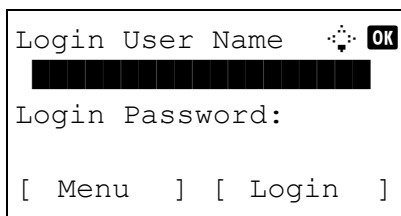

3 If user login administration is disabled, the user authentication screen appears. Enter your login user name and password and then press [Login]. For this, you need to log in with administrator privileges. Refer to *Adding a User on page 11-6* for the default login user name and password.

NOTE: If [Netwk Authentic.] is selected as the user authentication method, press [Menu] (the **Left Select** key) to select the authentication destination.

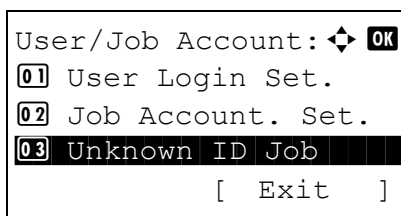

4 In the User/Job Account menu, press the Δ or ∇ key to select [Unknown ID Job].

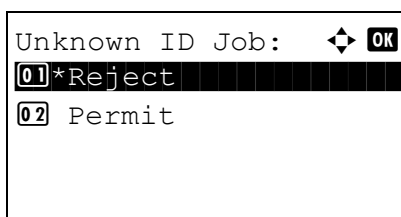

5 Press the **OK** key. Unknown ID Job appears.

6 Press the Δ or ∇ key to select [Reject] or [Permit].

7 Press the **OK** key.

Completed. is displayed and the screen returns to the User/Job Account menu.

Job Accounting

Job accounting Manages the copy/print count accumulated by individual accounts by assigning an ID to each account.

Job accounting helps the following activities in business organizations.

- Manageability of up to 20 individual accounts.
- Availability for account IDs with as many as eight digits (between 0 and 99999999) for security.
- Integrated management of printing and scanning statistics through the use of an identical account ID.
- Tracking the print volume for each account and for all accounts combined.
- Restricting the print counter in one-page increments up to 9,999,999 copies.
- Resetting the print counter for each account or for all accounts combined.

First Job Accounting Setup

Follow these steps for the first job accounting setup.

Enable job accounting. (page 11-13)



Add an account. (page 11-16)



Log out. (page 11-15)



Other users log in for operations. (page 11-15)

Enabling/Disabling Job Accounting

Enable job accounting. Use the procedure below to specify the job accounting setting.

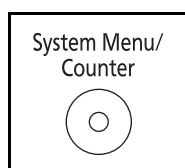

- 1 Press the **System Menu/Counter** key on the main unit operation panel.

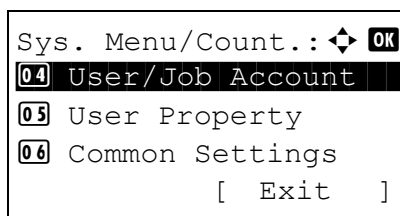

- 2 In the Sys. Menu/Count. menu, press the Δ or ∇ key to select [User/Job Account], and then press the **OK** key.

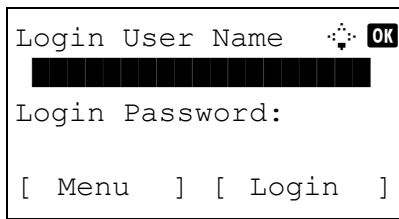

- 3 If user login administration is disabled, the user authentication screen appears. Enter your login user name and password and then press [Login]. For this, you need to log in with administrator privileges. Refer to *Adding a User on page 11-6* for the default login user name and password.

NOTE:

- Refer to *Character Entry Method on Appendix-5* for details on entering characters.
- If [Netwk Authentic.] is selected as the user authentication method, press [Menu] (the **Left Select** key) to select the authentication destination.

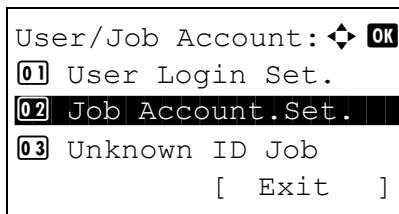

- 4 In the User/Job Account menu, press the Δ or ∇ key to select [Job Account. Set.].

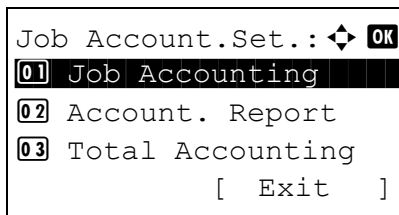

- 5 Press the **OK** key. The Job Account. Set. menu appears.

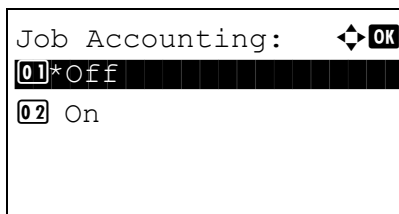

- 6 Press the Δ or ∇ key to select [Job Accounting].
- 7 Press the **OK** key. Job Accounting appears.

- 8 Press the Δ or ∇ key to select [On]. To disable job accounting, select [Off].

- 9 Press the **OK** key.

Completed. is displayed and the screen returns to the Job Account. Set. menu.

NOTE: When the display returns to the System Menu default screen, logout is automatically executed and the screen to enter the Account ID appears. To continue the operation, enter the Account ID.

Login/Logout

If job accounting is enabled, an account ID entry screen appears each time you use this machine.

Use the procedure below to login and logout.

Login

NOTE: Refer to *Character Entry Method on Appendix-5* for details on entering characters.

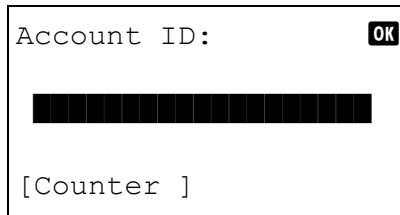

- 1 In the screen below, enter the account ID using the numeric keys and press the **OK** key.

NOTE: If you entered a wrong character, press the **Clear** key and enter the account ID again.

If the entered account ID does not match the registered ID, a warning beep will sound and login will fail. Enter the correct account ID.

By pressing [Counter] (the **Left Select** key), you can refer to the number of pages printed and the number of pages scanned.

When the screen to enter the login user name and password appears

If user login administration is enabled, the screen to enter the login user name and password appears. Enter a login user name and password to log in. (Refer to *Login/Logout on page 11-5.*) If the user has already registered the account information, the account ID entry would be skipped. (Refer to *Adding a User on page 11-6.*)

- 2 Proceed to complete the rest of the steps.

Logout

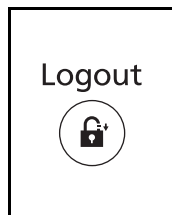

When the operations are complete, press the **Logout** key to return to the account ID entry screen.

Managing Accounts

This section explains how to add a new account. The following entries are required.

Item	Description
Account Name	Enter the account name (up to 32 characters).
Account ID	Enter the account ID as many as eight digits (between 0 and 99999999).
Restriction	This Prohibits printing/scanning or restricts the number of sheets to load. Refer to <i>Restricting the Use of the Machine</i> on page 11-22.

Use the procedure below to register a new account.

NOTE: Refer to *Character Entry Method* on Appendix-5 for details on entering characters.

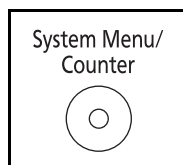

1 Press the **System Menu/Counter** key on the main unit operation panel.

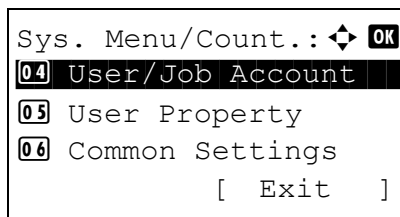

2 In the Sys. Menu/Count. menu, press the Δ or ∇ key to select [User/Job Account], and then press the **OK** key.

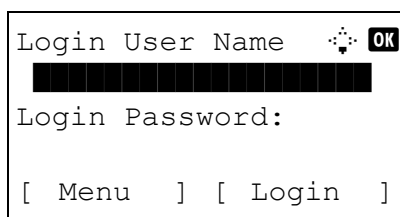

3 If user login administration is disabled, the user authentication screen appears. Enter your login user name and password and then press [Login]. For this, you need to log in with administrator privileges. Refer to *Adding a User* on page 11-6 for the default login user name and password.

NOTE: If [Netwk Authentic.] is selected as the user authentication method, press [Menu] (the **Left Select** key) to select the authentication destination.

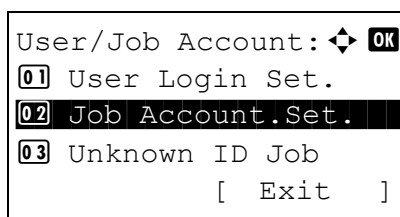

4 In the User/Job Account menu, press the Δ or ∇ key to select [Job Account. Set.].

```

Job Account.Set.:  OK
04 Each Job Account
05 Account. List
06 Default Setting
      [ Exit ]

```

- 5 Press the **OK** key. The Job Account. Set. menu appears.

```

Account. List:  OK
UI R&D DEP.
Osaka GUI Design
Kyoceramita
      [ Menu ]

```

- 6 Press the Δ or ∇ key to select [Account. List].

- 7 Press the **OK** key. Account. List appears.

```

Menu:  OK
01 Detail/Edit
02 Delete
03 Add Account

```

- 8 Press [Menu] (the **Right Select** key), press the Δ or ∇ key to select [Add Account], and then press the **OK** key.

```

Account Name:  OK
█
      ABC
      [ Text ]

```

- 9 Enter the account name and press the **OK** key.

```

Account ID:  OK
█████████████████████

```

- 10 Enter the account code and press the **OK** key.

NOTE: Any account ID that has already registered cannot be used. Enter any other account ID.

```

Dep.01:  OK
01 Exit
02 Detail

```

- 11 Press the Δ or ∇ key to select [Exit] and then press the **OK** key.

Select [Detail] and press the **OK** key to see information of the registered accounts.

- 12 Account. List is displayed and the new account is added to the account list.

Managing Accounts

This changes the registered account information or deletes the account.

Use the procedure below to manage accounts.

NOTE: Refer to *Character Entry Method on Appendix-5* for details on entering characters.

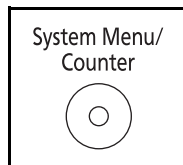

1 Press the **System Menu/Counter** key on the main unit operation panel.

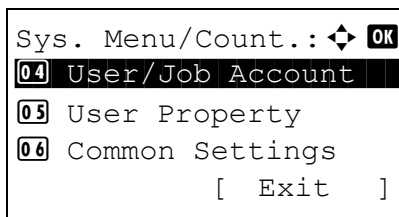

2 In the Sys. Menu/Count. menu, press the Δ or ∇ key to select [User/Job Account], and then press the **OK** key.

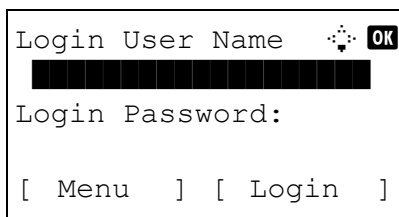

3 If user login administration is disabled, the user authentication screen appears. Enter your login user name and password and then press [Login]. For this, you need to log in with administrator privileges. Refer to *Adding a User on page 11-6* for the default login user name and password.

NOTE: If [Netwk Authentic.] is selected as the user authentication method, press [Menu] (the **Left Select** key) to select the authentication destination.

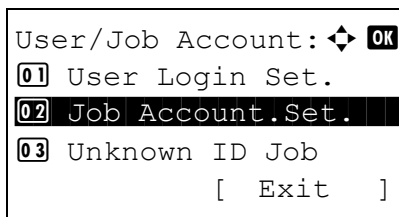

4 In the User/Job Account menu, press the Δ or ∇ key to select [Job Account. Set.].

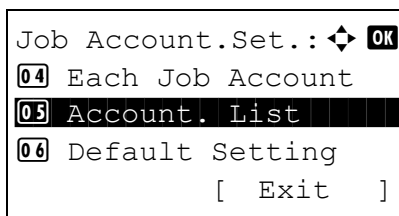

5 Press the **OK** key. The Job Account. Set. menu appears.

6 Press the Δ or ∇ key to select [Account. List].

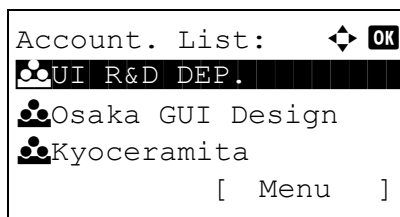

- 7 Press the **OK** key. Account. List appears.

The procedure differs depending on the details to be edited.

Changing account information

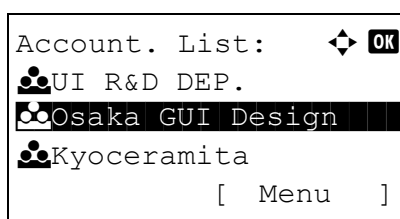

- 1 Press the Δ or ∇ key to select the account whose information you want to change, and then press the **OK** key.

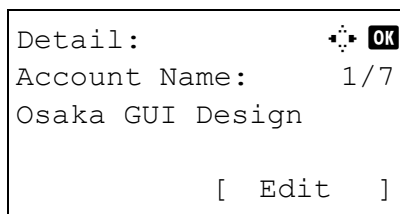

- 2 Press the \triangleleft or \triangleright key to select the item you want to change, press [Edit] (the **Right Select** key), change account information and restriction of use, and then press the **OK** key.

NOTE: Activate or deactivate restriction. Refer to *Restricting the Use of the Machine* on page 11-22.

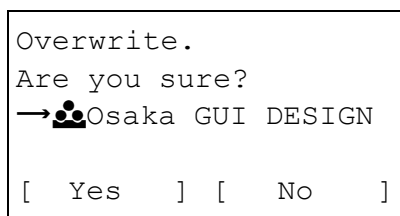

- 3 Repeat step 2 to change items as necessary.
- 4 After completing changing the account information, press the **OK** key again. A confirmation screen appears.

- 5 Press [Yes] (the **Left Select** key). The account information is changed. *Registered.* is displayed and the screen returns to Account. List.

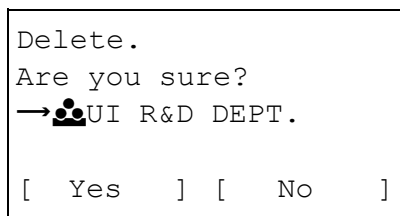
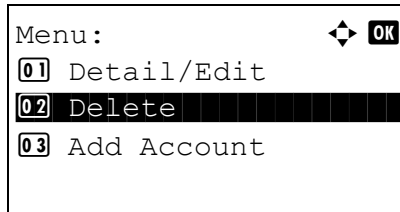
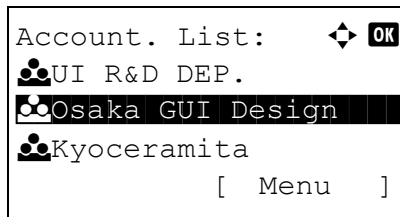

Deleting an account

- 1 Press the Δ or ∇ key to select the account you want to delete, and then press [Menu] (the **Right Select** key).
- 2 Press the Δ or ∇ key to select [Delete].
- 3 Press the **OK** key. A confirmation screen appears.
- 4 Press [Yes] (the **Left Select** key). The account is deleted. *Completed.* is displayed and the screen returns to Account. List.

Managing the Copier/Printer Counts

You can select how the copying and printing page counts are shown - either the total of both or each of copying and printing individually. The selection may influence restriction on the count and count method. Refer to *Restricting the Use of the Machine on page 11-22*, *Counting the Number of Pages Printed on page 11-30* and *Printing an Accounting Report on page 11-35* for details.

Use the procedure below to set the counting methods.

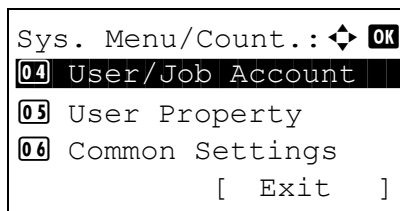
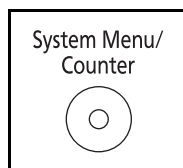

- 1 Press the **System Menu/Counter** key on the main unit operation panel.
- 2 In the Sys. Menu/Count. menu, press the Δ or ∇ key to select [User/Job Account], and then press the **OK** key.

```

Login User Name  [OK]
██████████████
Login Password:
[ Menu ] [ Login ]

```

- 3 If user login administration is disabled, the user authentication screen appears. Enter your login user name and password and then press [Login]. For this, you need to log in with administrator privileges. Refer to *Adding a User on page 11-6* for the default login user name and password.

NOTE:

- Refer to *Character Entry Method on Appendix-5* for details on entering characters.
- If [Netwk Authentic.] is selected as the user authentication method, press [Menu] (the **Left Select** key) to select the authentication destination.

```

User/Job Account: [OK]
[01] User Login Set.
[02] Job Account.Set.
[03] Unknown ID Job
           [ Exit ]

```

- 4 In the User/Job Account menu, press the Δ or ∇ key to select [Job Account. Set.].

```

Job Account.Set: [OK]
[01] Job Accounting
[02] Account Report
[03] Total Accounting
           [ Exit ]

```

- 5 Press the **OK** key. The Job Account. Set. menu appears.

```

Default Setting: [OK]
[01] Apply Limit
[02] Copy/Print Count
[03] Counter Limit
           [ Exit ]

```

- 6 Press the Δ or ∇ key to select [Default Setting].

- 7 Press the **OK** key. The Default Setting menu appears.

```

Copy/Print Count: [OK]
[01] Total
[02]*Split

```

- 8 Press the Δ or ∇ key to select [Copy/Print Count].

- 9 Press the **OK** key. Copy/Print Count appears.

- 10 Press the Δ or ∇ key to select [Total] or [Split].

11 Press the **OK** key.

Completed. is displayed and the screen returns to the Default Setting menu.

Restricting the Use of the Machine

This section explains how to restrict the use of the machine by account or the number of sheets available.

The items that can be restricted differ depending on whether [Split] or [Total] is selected for *Managing the Copier/Printer Counts* on page 11-20.

Restriction Items

◆ [Split] selected for *Copier/Printer Count*

Item	Detail
Print Restriction (Copier)	Limits the number of sheets used for copying.
Print Restriction (Printer)	Limits the number of sheets used for printing.
Scan Restriction (Others)	Limits the number of sheets scanned (excludes copying).
Fax TX Restriction	Limits the number of sheets sent by fax. (For FS-1128MFP only)

◆ [Total] selected for *Copier/Printer Count*

Item	Detail
Print Restriction	Limits the total number of sheets used for copying and printing.
Scan Restriction (Others)	Limits the number of sheets scanned (excludes copying).
Fax TX Restriction	Limits the number of sheets sent by fax. (For FS-1128MFP only)

Applying Restriction

Restriction can be applied in two modes as follows:

Item	Description
Off	No restriction given
Counter Limit	Restricts the print counter in one-page increments up to 9,999,999 copies.
Reject Usage	Restriction is applied.

Use the procedure below to select a restriction method.

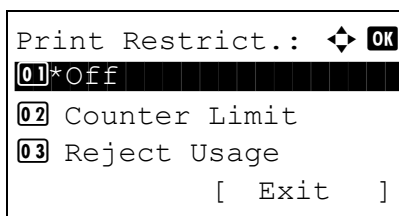
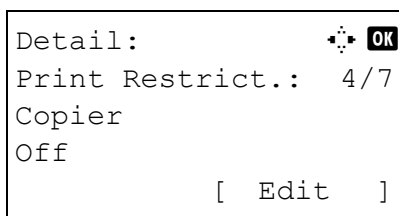
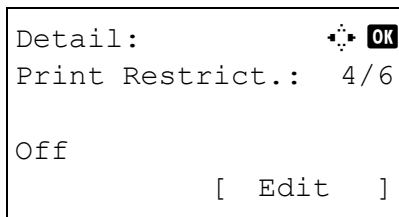
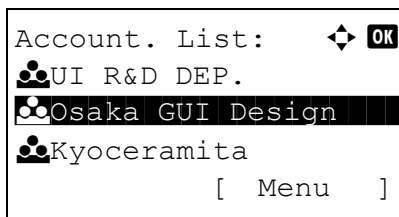

- 1 Follow steps 1 to 7 of *Managing Accounts* on page 11-16.
- 2 In Account. List, press the Δ or ∇ key to select the account to which you want to set restriction of use, and then press the **OK** key.
- 3 Press the \triangleleft or \triangleright key to select the item to be restricted and then press [Edit] (the **Right Select** key).

When selecting [Split] in Copy/Print Count, screen changes as shown in the left.

- 4 Press the Δ or ∇ key to select the desired restriction method and then press the **OK** key.

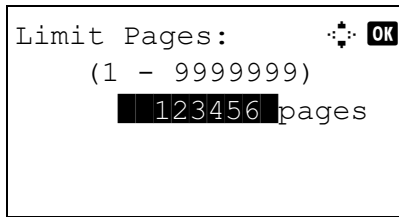

If you select [Counter Limit], enter the upper limit number of pages in the next screen, and then press the **OK** key.

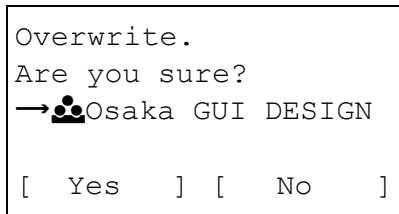

5 Repeat step 3 to 4 to set items as necessary.

6 Press the **OK** key again. A confirmation screen appears.

7 Press [Yes] (the **Left Select** key). The restriction of use is changed. *Registered.* is displayed and the screen returns to Account. List.

Applying Limit of Restriction

This specifies how the machine behaves when the counter has reached the limit of restriction. The table below describes the action taken.

Item	Description
Immediately *	Job stops when the counter reaches its limit.
Subsequently	Printing/scanning of the job continues but the subsequent job will be rejected.
Alert Only	Job continues while displaying an alert message.

* The next job will be prohibited in sending or in storing in the box.

Use the procedure below to apply the restriction limit.

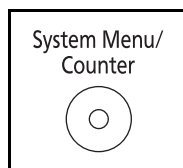

1 Press the **System Menu/Counter** key on the main unit operation panel.

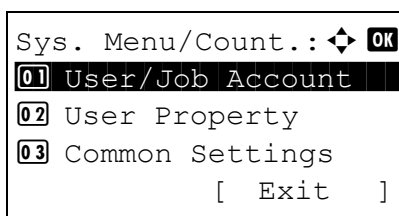

2 In the Sys. Menu/Count. menu, press the Δ or ∇ key to select [User/Job Account], and then press the **OK** key.

```

Login User Name  [OK]
██████████████
Login Password:
[ Menu ] [ Login ]

```

- 3 If user login administration is disabled, the user authentication screen appears. Enter your login user name and password and then press [Login]. For this, you need to log in with administrator privileges. Refer to *Adding a User on page 11-6* for the default login user name and password.

NOTE:

- Refer to *Character Entry Method on Appendix-5* for details on entering characters.
- If [Netwk Authentic.] is selected as the user authentication method, press [Menu] (the **Left Select** key) to select the authentication destination.

```

User/Job Account: [OK]
01 User Login Set.
02 Job Account.Set.
03 Unknown ID Job
[ Exit ]

```

- 4 In the User/Job Account menu, press the Δ or ∇ key to select [Job Account. Set.].

```

Job Account.Set.: [OK]
04 Each Job Account
05 Account. List
06 Default Setting
[ Exit ]

```

- 5 Press the **OK** key. The Job Account. Set. menu appears.

```

Default Setting: [OK]
01 Apply Limit
02 Copy/Print Count
03 Counter Limit
[ Exit ]

```

- 6 Press the Δ or ∇ key to select [Default Setting].
- 7 Press the **OK** key. The Default Setting menu appears.

```

Apply Limit: [OK]
01 Immediately
02*Subsequently
03 Alert Only
[ Exit ]

```

- 8 Press the Δ or ∇ key to select [Apply Limit].
- 9 Press the **OK** key. Apply Limit appears.

- 10 Press the Δ or ∇ key to select [Immediately], [Subsequently] or [Alert Only].

11 Press the **OK** key.

Completed. is displayed and the screen returns to the Default Setting menu.

Default Counter Limit

When you add a new account, you can change the default restrictions on the number of sheets used.

You can set any number from 1 to 9,999,999 in 1-sheet increments.

The items that can be set differ depending on whether [Split] or [Total] is selected for *Managing the Copier/Printer Counts* on page 11-20.

Available Settings

◆ [Split] selected for *Copier/Printer Count*

Item	Detail
Copy Restriction	Sets the default restriction on the number of sheets used for copying.
Print Restriction	Sets the default restriction on the number of sheets used for printing.
Scan Restriction (Other)	Sets the default restriction on the number of sheets used for scanning (excludes copying).
FAX TX Restriction	Sets the default restriction on the number of sheets used for sending faxes. (For FS-1128MFP only)

◆ [Total] selected for *Copier/Printer Count*

Item	Detail
Print Restriction	Sets the default restriction on the total number of sheets used for copying and printing.
Scan Restriction (Other)	Sets the default restriction on the number of sheets used for scanning (excludes copying).
FAX TX Restriction	Sets the default restriction on the number of sheets used for sending faxes. (For FS-1128MFP only)

Use the procedure below to specify the counter limits.

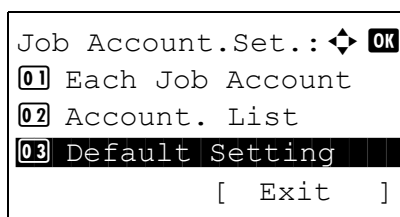
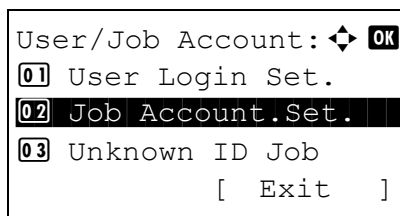
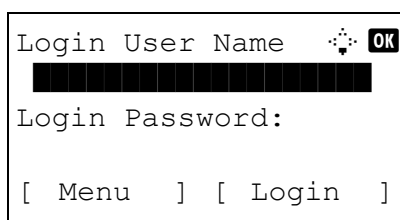
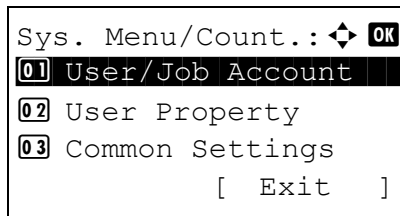
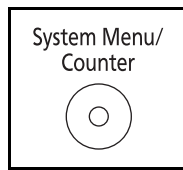

- 1 Press the **System Menu/Counter** key on the main unit operation panel.
- 2 In the Sys. Menu/Count. menu, press the Δ or ∇ key to select [User/Job Account], and then press the **OK** key.
- 3 If user login administration is disabled, the user authentication screen appears. Enter your login user name and password and then press [Login]. For this, you need to log in with administrator privileges. Refer to *Adding a User on page 11-6* for the default login user name and password.

NOTE:

- Refer to *Character Entry Method on Appendix-5* for details on entering characters.
- If [Netwk Authentic.] is selected as the user authentication method, press [Menu] (the **Left Select** key) to select the authentication destination.

- 4 In the User/Job Account menu, press the Δ or ∇ key to select [Job Account. Set.].
- 5 Press the **OK** key. The Job Account. Set. menu appears.
- 6 Press the Δ or ∇ key to select [Default Setting].

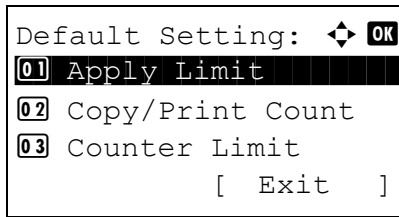

7 Press the **OK** key. The Default Setting menu appears.

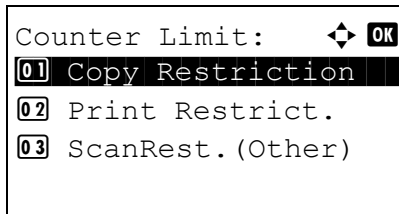

8 Press the Δ or ∇ key to select [Counter Limit].

9 Press the **OK** key. Counter Limit appears.

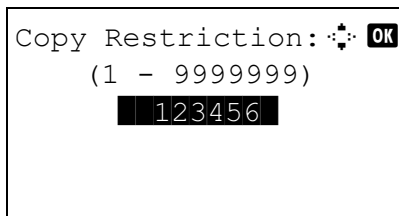

10 Press the Δ or ∇ key to select the item for which you want to set the default restriction on the number of sheets, and then press the **OK** key.

11 Use the numeric keys to enter the default restriction on the number of sheets, and then press the **OK** key.

Completed. is displayed and the screen returns to Counter Limit.

12 Repeat steps 10 to 11 set other default restrictions on the number of sheets.

Counting the Number of Pages Printed

This counts the number of pages printed. Counts are classified into Total Job Accounting and Each Job Accounting. A new count can also be started after resetting the count data which was stored for a certain period of time.

Types of the counts are as follows.

Item	Detail
Printed Pages	Displays the number of pages copied and printed, and the total number of pages used. You can also use [Duplex Pages] and [Combine Pages] to check the number of pages used.
Scanned Pages	Displays the number of pages scanned for copying, faxing* and other functions, as well as the total number of pages scanned.
FAX TX Pages*	Displays the number of pages faxed.
FAX TX Time*	Displays the total duration of fax transmissions.

* FAX functions available only in FS-1128MFP.

Total Job Accounting/Resetting the Counter

This counts the number of pages for all accounts and resets the counts for those accounts together at the same time.

Use the procedure below to check and reset the counter.

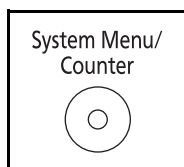

1 Press the **System Menu/Counter** key on the main unit operation panel.

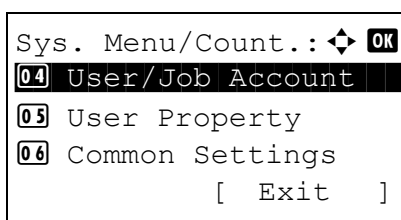

2 In the Sys. Menu/Count. menu, press the Δ or ∇ key to select [User/Job Account], and then press the **OK** key.

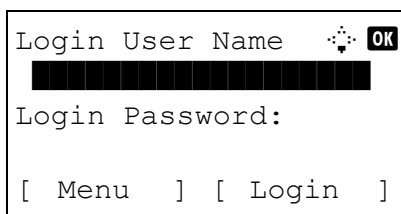

3 If user login administration is disabled, the user authentication screen appears. Enter your login user name and password and then press [Login]. For this, you need to log in with administrator privileges. Refer to *Adding a User* on page 11-6 for the default login user name and password.

```

User/Job Account: ⬅️ OK
01 User Login Set.
02 Job Account.Set.
03 Unknown ID Job
      [ Exit ]

```

```

Job Account.Set: ⬅️ OK
01 Job Accounting
02 Account. Report
03 Total Accounting
      [ Exit ]

```

```

Total Accounting: ⬅️ OK
01 Printed Pages
02 Scanned Pages
03 FAX TX Pages
      [ Exit ]

```

```

Copy/Print Pages: ⬅️ OK
Copy:                1/3
      1234567

```

NOTE:

- Refer to *Character Entry Method on Appendix-5* for details on entering characters.
- If [Netwk Authentic.] is selected as the user authentication method, press [Menu] (the **Left Select** key) to select the authentication destination.

4 In the User/Job Account menu, press the Δ or ∇ key to select [Job Account. Set.].

5 Press the **OK** key. The Job Account. Set. menu appears.

6 Press the Δ or ∇ key to select [Total Accounting].

7 Press the **OK** key. The Total Accounting menu appears.

8 Press the Δ or ∇ key to select the function of which you want to check counts, and then press the **OK** key.

If you select [Printed Pages] or [Scanned Pages], press the \triangleleft or \triangleright key to switch the counted items.

9 After confirming the content, press the **OK** key. The screen returns to the Total Accounting menu.

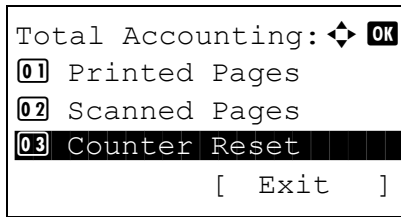

10 To reset the counter, press the Δ or ∇ key to select [Counter Reset].

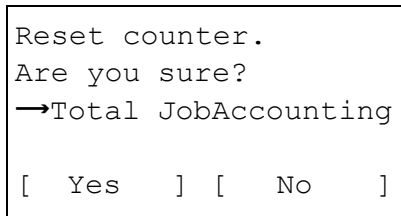

11 Press the **OK** key. A confirmation screen appears.

12 Press [Yes] (the **Left Select** key). The counter is reset. *Completed.* is displayed and the screen returns to the Total Accounting menu.

Each Job Accounting/Resetting the Counter

This counts the number of pages for each account and resets the counts by account.

Use the procedure below to display and reset the counter.

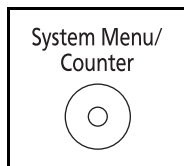

1 Press the **System Menu/Counter** key on the main unit operation panel.

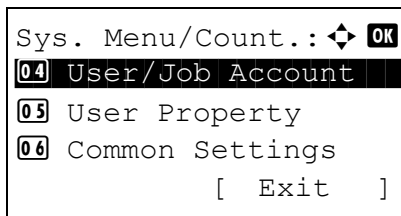

2 In the Sys. Menu/Count. menu, press the Δ or ∇ key to select [User/Job Account], and then press the **OK** key.

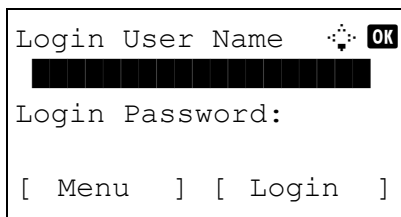

3 If user login administration is disabled, the user authentication screen appears. Enter your login user name and password and then press [Login]. For this, you need to log in with administrator privileges. Refer to *Adding a User on page 11-6* for the default login user name and password.

```

User/Job Account: [OK]
01 User Login Set.
02 Job Account.Set.
03 Unknown ID Job
      [ Exit ]

```

```

Job Account.Set.: [OK]
04 Each Job Account
05 Account List
06 Default Setting
      [ Exit ]

```

```

Each Job Account: [OK]
Osaka GUI DESIGN
Kyoceramita
UI R&D DEPT.

```

```

Osaka GUI DESIGN: [OK]
01 Printed Pages
02 Scanned Pages
03 Counter Reset
      [ Exit ]

```

NOTE:

- Refer to *Character Entry Method on Appendix-5* for details on entering characters.
- If [Netwk Authentic.] is selected as the user authentication method, press [Menu] (the **Left Select** key) to select the authentication destination.

4 In the User/Job Account menu, press the Δ or ∇ key to select [Job Account. Set.].

5 Press the **OK** key. The Job Account. Set. menu appears.

6 Press the Δ or ∇ key to select [Each Job Account].

7 Press the **OK** key. The Each Job Accounting menu appears.

8 Press the Δ or ∇ key to select the account of which you want to check counts.

9 Press the **OK** key. A menu for the account appears.

10 Press the Δ or ∇ key to select the function of which you want to check counts, and then press the **OK** key.

If you select [Printed Pages], select the item for which you want to check printed page counts, and then press the **OK** key. Press the \triangleleft or \triangleright key to switch the counted items.

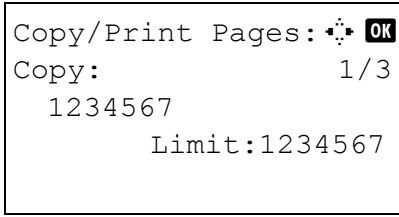

If you select [Scanned Pages], press the < or > key to switch the counted items.

If the number of output sheets is restricted by an account management function, the upper limit on the number of output sheets is also displayed.

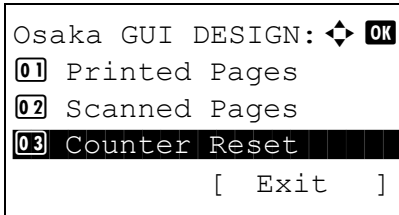

11 After confirming the content, press the **OK** key. The screen returns to the menu for the account.

12 To reset the counter, press the Δ or ∇ key to select [Counter Reset].

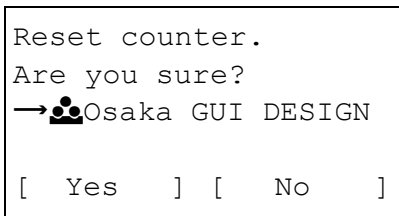

13 Press the **OK** key. A confirmation screen appears.

14 Press [Yes] (the **Left Select** key). The counter is reset. *Completed.* is displayed and the screen returns to the menu for the account.

Printing an Accounting Report

Total pages counted at all relevant accounts can be printed as an accounting report.

Reports have different formats depending on how the count of copiers and printers is administered.

When Split is selected for Managing the Copier/Printer Count

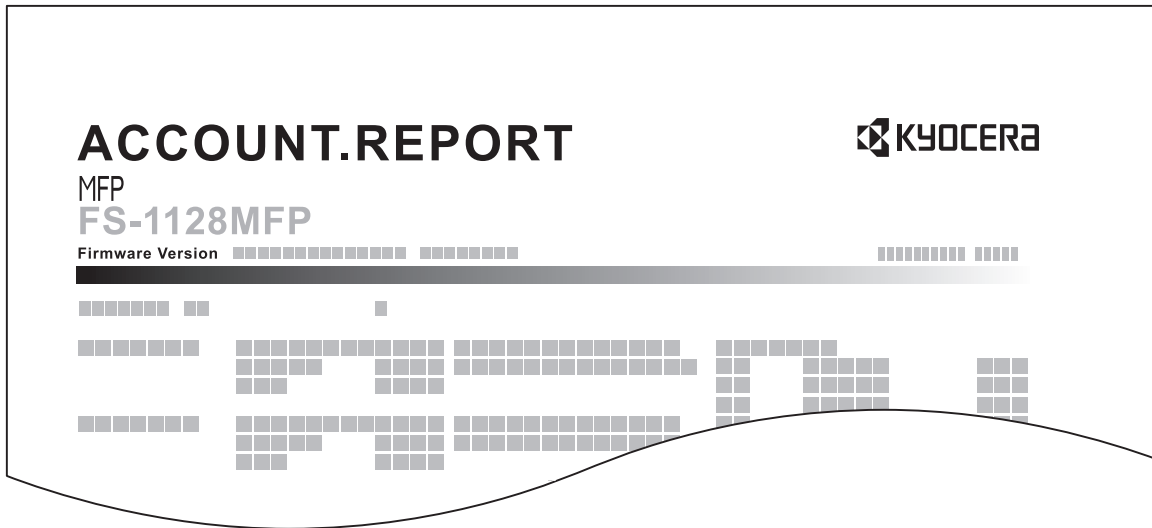

For the count by paper size, the report will be printed by size.

Use the procedure below to print a job accounting report.

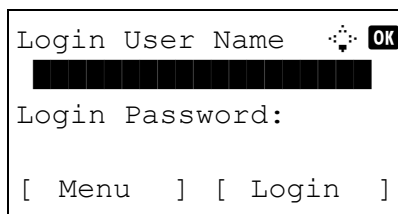
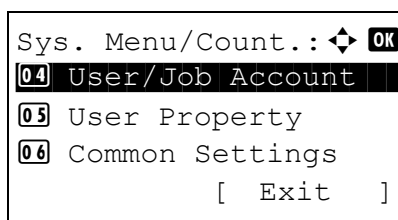
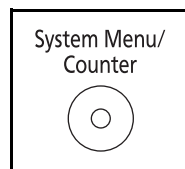

- 1 Press the **System Menu/Counter** key on the main unit operation panel.
- 2 In the Sys. Menu/Count. menu, press the Δ or ∇ key to select [User/Job Account], and then press the **OK** key.
- 3 If user login administration is disabled, the user authentication screen appears. Enter your login user name and password and then press [Login]. For this, you need to log in with administrator privileges. Refer to *Adding a User* on page 11-6 for the default login user name and password.

```
User/Job Account:  
01 User Login Set.
02 Job Account.Set.
03 Unknown ID Job
      [ Exit ]
```

```
Job Account.Set:  
01 Job Accounting
02 Account. Report
03 Total Accounting
      [ Exit ]
```

```
Print.
Are you sure?
→Total JobAccounting
[ Yes ] [ No ]
```

NOTE:

- Refer to *Character Entry Method on Appendix-5* for details on entering characters.
 - If [Netwk Authentic.] is selected as the user authentication method, press [Menu] (the **Left Select** key) to select the authentication destination.
-

4 In the User/Job Account menu, press the Δ or ∇ key to select [Job Account. Set.].

5 Press the **OK** key. The Job Account. Set. menu appears.

6 Press the Δ or ∇ key to select [Account. Report] and then press the **OK** key.

7 In the confirmation screen, press [Yes] (the **Left Select** key). A job accounting report is printed.

Checking the Counter

You can check the number of pages printed and scanned.

The number is counted by the following items:

Item		Description
Printed Pages	By Function	You can check the number of pages copied, faxed*, and printed, and the total number of pages used.
	By Paper Size	You can check the number of pages printed for each paper size.
Scanned Pages		You can check the number of pages copied, faxed*, and otherwise scanned, and the total number of pages used.

* FAX functions available only in FS-1128MFP.

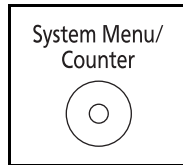

1 Press the **System Menu/Counter** key on the main unit operation panel.

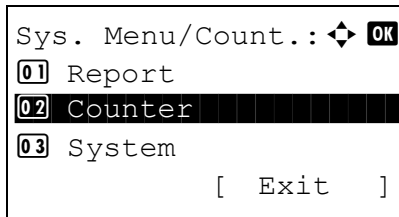

2 In the Sys. Menu/Count. menu, press the Δ or ∇ key to select [Counter], and then press the **OK** key.

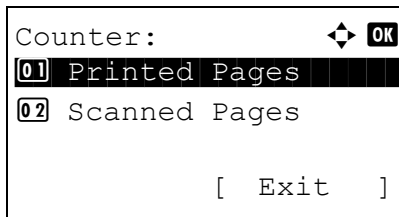

3 Press the Δ or ∇ key to select [Printed Pages] or [Scanned Pages], and then press the **OK** key.

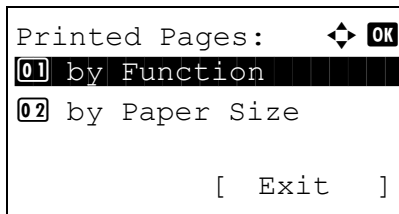

If you select [Printed Pages], select [by Function] or [by Paper Size] in the next screen, and then press the **OK** key.

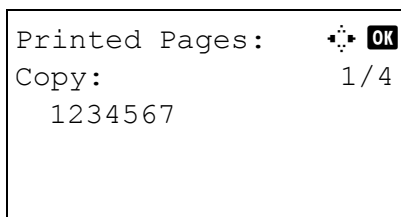

4 Press the ◀ or ▶ key to check the count.

5 After completing checking the count, press the **OK** key. The screen returns to the menu for the account.

Appendix

- Optional EquipmentAppendix-2
- Character Entry Method.....Appendix-5
- PaperAppendix-9
- SpecificationsAppendix-18
- Glossary.....Appendix-23

Optional Equipment

Overview of Optional Equipment

The following optional equipment is available for the machine.

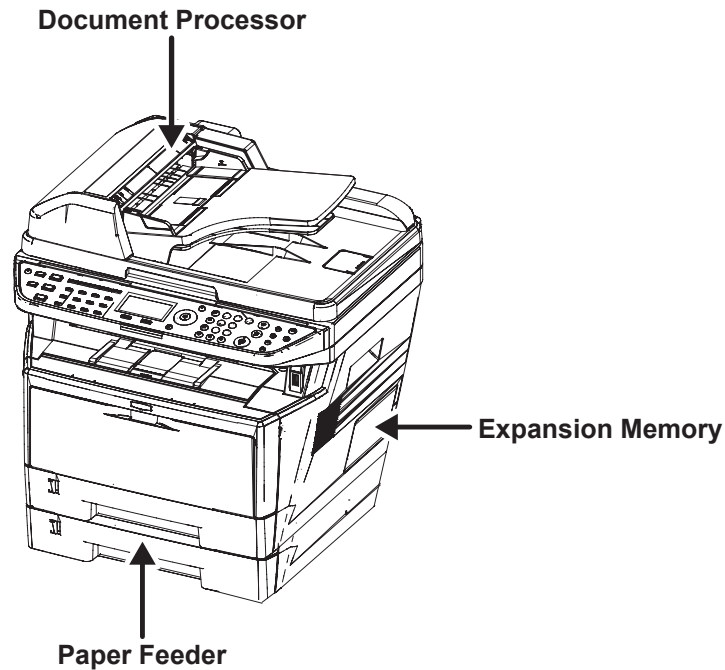

Document Processor (DP-110)

Automatically scans originals. Also you can perform duplex copying and split copying.

For document processor operation, refer to *Loading Originals in the Document Processor* on page 2-45.

Paper Feeder (PF-100)

Two additional cassettes identical to the machine's double cassettes can be installed in the machine. Paper capacity and loading method are the same as Cassettes 1.

Expansion Memory

To expand the printer memory for more complex print jobs and faster print speed, you can plug in optional memory module (dual in line memory module) in the memory slot provided on the main controller board. You can select additional memory module from 128, 256, 512, or 1024 MB. The maximum memory size is 768 MB.

NOTE: The expansion memory should only be installed by your service technician. We shall not be liable for any damages caused by improper installation of expansion memory.

Precautions for Handling the Memory Module

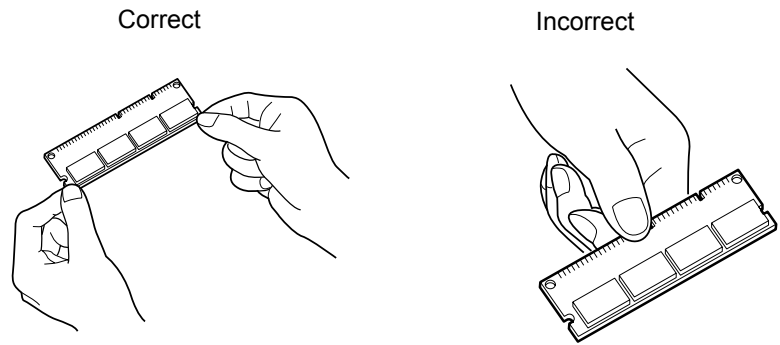

To protect electronic parts, discharge static electricity from your body by touching a water pipe (faucet) or other large metal object before handling the memory module. Or, wear an antistatic wrist strap, if possible, when you install the memory module.

Installing the Memory Module

- 1 Turn off the machine and disconnect the power cord and interface cable.
- 2 Remove the right cover with a piece of metal similar to coin.
- 3 Remove the screws and the memory slot cover as shown in the figure.

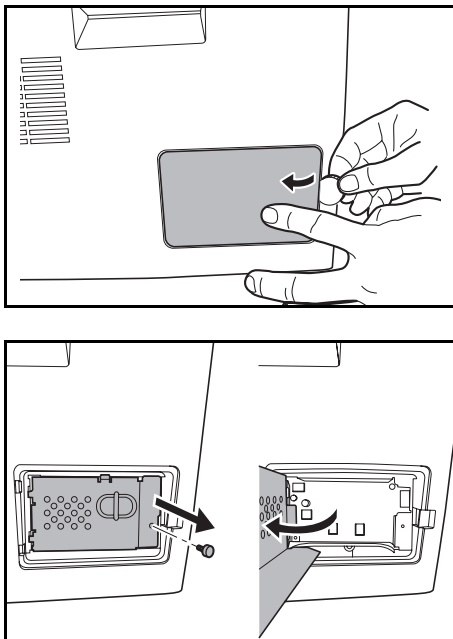

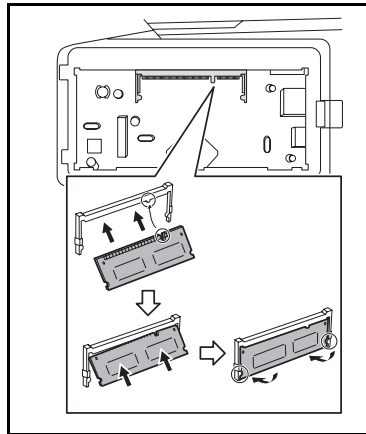

- 4 Remove the memory module from its package.
- 5 Aligning the cutouts of the memory module with the matching keys of the socket, carefully plug the memory module into the memory socket until it clicks in place. Then, push down the memory module to secure.

CAUTION: Before inserting a memory module in the machine, make sure that the machine is switched off.

- 6 Push down the memory module to secure.
- 7 Reinstall the right cover.

Removing the Memory Module

To remove a memory module, remove the right cover and the memory slot cover from the machine. Then, carefully push out the two socket clamps. Ease the memory module out of the socket to remove.

Verifying the expanded memory

To verify that the memory module is working properly, test it by printing a status page.

Character Entry Method

In character entry screens, use the procedure below to enter characters.

Keys Used

Use the following keys to enter characters.

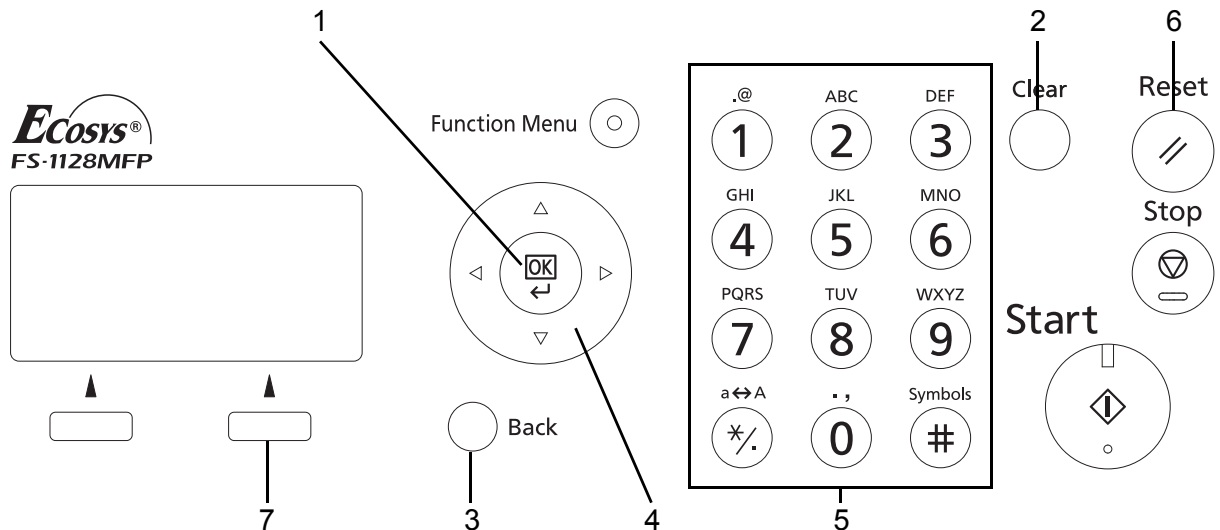

- 1. OK Key** Press this key to finalize the entered character(s).
- 2. Clear Key** Press this key to delete the character at the cursor position. If the cursor is at the end of the line, the character to the left of it is deleted.
- 3. Back Key** Press this key to return to the screen from which you invoked the character entry screen.
- 4. Cursor Keys** Use these to select the entry position, or select a character from the character list.
- 5. Numeric Keys** Use these keys to select the character you want to enter.
- 6. Reset Key** Press this key to cancel the character entry procedure and return to the standby screen.
- 7. Right Select Key** Press this key to select the type of characters you want to enter. (When [Text] is displayed)

Selecting Type of Characters

To enter characters, the following three types are available:

- ABC** To enter alphabets.
- 123** To enter numerals.
- Symbols** To enter symbols.

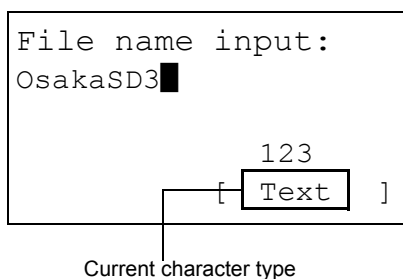

In a character entry screen, press [Text] (the **Right Select** key) to select the type of characters you want to enter.

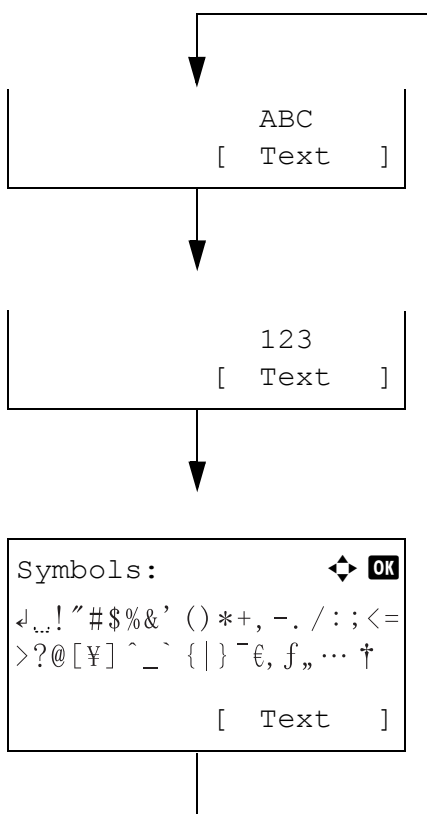

Each time you press [Text] (the **Right Select** key), the character type switches as follows: ABC, 123, Symbol, ABC ...

NOTE: By pressing  on the numeric keys while entering characters, you can directly display the Symbols screen.

Entering Characters

After selecting a character type, use the procedure below to enter characters.

Entering Alphabets and Numerals

Referring to the table below, press the key corresponding to the character you want to enter until it is displayed.

Key	Entry mode	Available characters
① . @	Alphabetic/Symbol	. @ - _ / : ' 1
	Numeric	1
② ABC	Alphabetic/Symbol	a b c A B C 2
	Numeric	2
③ DEF	Alphabetic/Symbol	d e f D E F 3
	Numeric	3
④ GHI	Alphabetic/Symbol	g h i G H I 4
	Numeric	4
⑤ JKL	Alphabetic/Symbol	j k l J K L 5
	Numeric	5
⑥ MNO	Alphabetic/Symbol	m n o M N O 6
	Numeric	6
⑦ PQRS	Alphabetic/Symbol	p q r s P Q R S 7
	Numeric	7
⑧ TUV	Alphabetic/Symbol	t u v T U V 8
	Numeric	8
⑨ WXYZ	Alphabetic/Symbol	w x y z W X Y Z 9
	Numeric	9
⑩ .,	Alphabetic/Symbol	. , - _ ' ! ? (space) 0
	Numeric	0
⑪ a↔A */.	Alphabetic/Symbol	Switch between upper-/lowercase
	Numeric	* or . (decimal point)*
⑫ Symbols #	Alphabetic/Symbol	#
	Numeric	

* '*' is entered when [123] is selected in the character type selection, or '.' is entered when only numerals are entered and no character type is selected.

Characters associated with different keys can be entered consecutively. To enter a character associated with the same key after another, use cursor keys to move the cursor to the next entry position before entering it.

If you use cursor keys to move the cursor to an entry position apart from the end of the line and enter a character there, spaces are automatically entered in between.

Entering Symbols

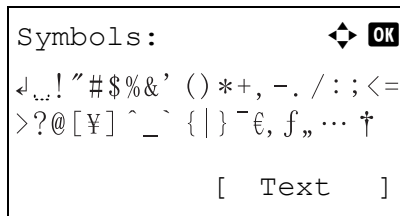

Press [Text] (the **Right Select** key) or # on the numeric keys to display the Symbols screen. Use cursor keys to select the symbol you want to enter and then press the **OK** key.

Entry When [Select Character] Is Selected in Login Operation Settings

In the login screen that appears when user management is enabled, the character entry method may vary depending on the settings. (Refer to *Login Operation on page 8-55*.)

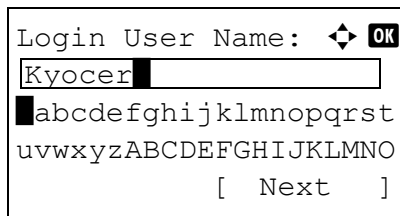

If a character palette appears on the screen, use cursor keys to select the desired character from the displayed characters, and then press the **OK** key to enter it.

NOTE: Numerals can be entered directly by pressing numeric keys.

Paper

This section explains the paper sizes and types that can be used in the paper source.

Cassette

Supported types	Supported paper sizes	No. of sheets
Plain, Preprinted, Bond, Recycled, Rough, Letterhead, Color (Colour), Prepunched, High Quality, Custom 1 to 8	A4, JIS B5, A5, Folio, Legal, Letter, Oficio II, Statement, Executive, A6, B6, ISO B5, Envelope C5, 16K, Custom (105 x 148 to 216 x 356mm (4-1/8 x 5-13/16 to 8-1/2 x 14 inches)	250 (80g/m ²)

Optional paper feeder

Supported types	Supported paper sizes	No. of sheets
Plain, Preprinted, Bond, Recycled, Rough, Letterhead, Color (Colour), Prepunched, High Quality, Custom 1 to 8	A4, JIS B5, A5, Folio, Legal, Letter, Oficio II, Executive, B6, ISO B5, Envelope C5, 16K, Custom (148 x 210 to 216 x 356mm (5-13/16 x 8-5/16 to 8-1/2 x 14 inches)	250 (80g/m ²)

Multi Purpose tray (MP tray)

Supported types	Supported paper sizes	No. of sheets
Plain, , Preprinted, Labels, Bond, Recycled, Rough, Vellum, Letterhead, Color (Colour), High Quality, Custom 1 to 8	Letter, Legal, Statement, Executive, Oficio II, A4, A5, A6, B5, B6, Folio, 16k Other sizes: Portrait-2.76 to 8.50" or 70 to 216 mm Landscape-5.83 to 14.02" or 148 to 356 mm	50 (80g/m ²)
Thick paper	A4, JIS B5, A5, Folio, Legal, Letter, Oficio II, Statement, Executive, A6, B6, ISO B5, 16K Other sizes: Portrait-2.76 to 8.50" or 70 to 216 mm Landscape-5.83 to 14.02" or 148 to 356 mm	1
Postcards Oufuku Hagaki (return postcard)	Postcards (100 × 148 mm) Return postcard (148 × 200 mm)	15

Supported types	Supported paper sizes	No. of sheets
Envelopes	ISO B5, Envelope #10, Envelope #9, Envelope #6, Envelope Monarch, Envelope DL, Envelope C5, Hagaki, Oufuku Hagaki, Youkei 4, Youkei 2 Other sizes: Portrait-2.76 to 8.50" or 70 to 216 mm Landscape-5.83 to 14.02" or 148 to 356 mm	1
Transparency (OHP film)	Letter, A4	1

Basic Paper Specifications

This machine is designed to print on standard copy paper as used in regular ('dry') copiers and page printers such as laser printers. It also supports a variety of other types of paper that conform to the specifications given in this appendix.

Be careful when choosing paper. Paper unsuitable for the machine may cause jams or may be wrinkled.

Supported Paper

Use standard copy paper for regular copiers or laser printers. The printing quality will be affected by the quality of paper. Poor quality paper may result in unsatisfactory output.

Basic Paper Specifications

The following table lists the specifications of paper that is supported with this machine. Refer to the subsequent sections for further details.

Criteria	Specifications
Weight	Cassettes: 60 to 120 g/m ²
	Multi purpose tray: 60 to 220 g/m ²
Thickness	0.086 to 0.110 mm
Dimensional accuracy	±0.7 mm
Squareness of corners	90° ±0.2°
Moisture content	9%
Grain direction	Long grain (paper supply direction)
Pulp content	80% or more

NOTE: Some recycled paper does not meet requirements for use with this machine as listed in the Basic Paper Specifications shown below, such as moisture or pulp content. For this reason, we recommend purchasing a small amount of recycled paper as a sample for testing prior to use. Choose recycled paper that gives the best printing results and contains low levels of paper dust.

We are not responsible for the problems occurred from the use of paper that does not conform to our specifications.

Choosing the Appropriate Paper

This section describes guidelines for choosing paper.

Condition

Avoid using paper with bent corners or that is curled, dirty, or torn. Do not use paper that has a rough surface or paper fiber lint, or that is especially delicate. Use of paper in any of these conditions will not only deliver poor copies but may also cause jams and shorten the useful life of the machine. Choose paper with a smooth and even surface; however, avoid coated paper or paper with a treated surface as it may damage the drum or fusing unit.

Ingredient

Do not use paper such as paper that has been coated or surface-treated or paper that contains plastic or carbon. These paper may produce harmful fumes from the heat of printing and may damage the drum.

Be sure to use the standard paper that contains at least 80% pulp, i.e., not more than 20% of the total paper content consists of cotton or other fibers.

Supported Paper Sizes

Paper of the following sizes is supported by the machine.

Measurements in the table take into account a ± 0.7 mm dimensional accuracy for length and width. Corner angles must be $90^\circ \pm 0.2^\circ$.

Multi Purpose Tray	Cassette or Multi Purpose Tray
B6 (128 × 182 mm)	Letter
ISO B5 (176 × 250 mm)	Legal
Envelope #10 (Commercial #10) (4 1/8 × 9 1/2")	Statement *
Envelope #9 (Commercial #9) (3 7/8 × 8 7/8")	Executive
Envelope #6 (Commercial #6 3/4) (3 5/8 × 6 1/2")	Oficio II
Envelope Monarch (3 7/8 × 7 1/2")	A4 (297 × 210 mm)
Envelope DL (110 × 220 mm)	A5 (210 × 148 mm)
Envelope C5 (162 × 229mm)	A6 (105 × 148 mm) *
Hagaki (100 × 148mm)	B5 (257 × 182 mm)
Oufuku Hagaki (148 × 200 mm)	Folio (210 × 330 mm)
Youkei 4 (105 × 235 mm)	16K (273 × 197 mm)
Youkei 2 (114 × 162 mm)	
Size Entry (70 × 148 to 216 × 356 mm)	

* Except for the optional cassettes.

Smoothness

The paper surface should be smooth, but it must be uncoated. With paper that is too smooth and slippery, several sheets may accidentally be supplied at once, causing jams.

Basis Weight

In countries that use the metric system, basis weight is the weight in grams of one sheet of paper one square meter in area. In the United States, basis weight is the weight in pounds of one ream (500 sheets) of paper cut to the standard size (or trade size) for a specific grade of paper. Paper that is too heavy or too light may be supplied incorrectly or cause paper jams, which may cause excessive wear of the machine. Mixed paper weight (i.e., thickness) may cause several sheets to be supplied at once accidentally and may also cause blurring or other printing problems if the toner fails to adhere correctly.

The recommended basis weight is between 60 and 120 g/m² for the cassettes and between 60 and 220 g/m² for the multi purpose tray.

Thickness

Avoid using paper that is too thick or thin. Signs that paper may be thin include frequent problems with paper jams or with several sheets being supplied at once. Paper jams may also indicate that the paper is too thick. The proper thickness is between 0.086 and 0.110 mm.

Moisture Content

Paper moisture content is the ratio of moisture to dryness expressed as a percentage. Moisture affects how the paper is supplied, the electrostatic changeability of the paper, and how the toner adheres.

Paper moisture content varies depending on the relative humidity in the room. High relative humidity causes paper to become damp, making the edges expand so it appears wavy. Low relative humidity causes paper to lose moisture, making the edges tighten and weakening print contrast.

Wavy or tight edges may cause the paper to slip when it is supplied. Try to keep the moisture content between 4 to 6%.

To maintain the right level of moisture content, bear in mind the following considerations.

- Store paper in a cool, well-ventilated place.
- Store paper flat and unopened in the package. Once the package is opened, reseal it if the paper is not to be used for a while.
- Store paper sealed in the original package and box. Put a pallet under the carton to keep it raised above the floor. Especially during rainy seasons keep the paper a sufficient distance away from wooden or concrete floors.
- Before using paper that has been stored, keep it at the proper moisture level for at least 48 hours.
- Do not store paper where it is exposed to heat, sunlight, or dampness.

Other Paper Specifications

Porosity: The density of the paper fibers

Stiffness: Paper must be stiff enough or it may buckle in the machine, causing jams.

Curl: Most paper naturally tends to curl after the package is opened. When paper passes through the fixing unit, it curls upward slightly. To deliver flat printouts, load the paper so that the curl faces towards the bottom of the paper tray.

Static electricity: During printing, paper is electrostatically charged so that the toner adheres. Choose paper that can be discharged quickly so that copies do not cling together.

Whiteness: Paper whiteness affects print contrast. Use whiter paper for sharper, brighter copies.

Quality: Machine problems may occur if sheet sizes are not uniform or if corners are not square, edges are rough, sheets are uncut, or edges or corners are crushed. In order to prevent these problems, be especially careful when you cut the paper yourself.

Packaging: Choose paper that is properly packaged and stacked in boxes. Ideally, the packaging itself should have been treated with a coating to inhibit moisture.

Specially treated paper: We do not recommend printing onto the following types of paper, even if it conforms to the basic specifications. When you use these kinds of paper, purchase a small amount first as a sample to test.

- Glossy paper
- Watermarked paper
- Paper with an uneven surface
- Perforated paper

Special Paper

This section describes printing onto special paper and print media.

The following paper and media can be used.

- Transparency (OHP film)
- Rough
- Vellum
- Labels
- Recycled
- Preprinted
- Bond
- Cardstock
- Color (Colour)
- Prepunched
- Letterhead
- Envelope
- Thick
- High Quality
- Custom 1 to 8

When using these paper and media, choose that are designed specifically for copiers or page printers (such as laser printers). Use the multi purpose tray for transparencies, thick paper, envelopes, cardstocks, and label paper.

Choosing Special Paper

Although special paper that meets the following requirements can be used with the machine, print quality will vary considerably due to differences in the construction and quality of special paper. Thus, special paper is more likely than regular paper to cause printing problems. Before purchasing special paper in volume, try testing a sample to ensure the print quality is satisfactory. General precautions when printing onto special paper are given below. Note that we are not responsible for any harm to the user or damage to the machine caused by moisture or specifications of special paper.

Select a cassette or multi purpose tray for special paper.

Transparency (OHP film)

Transparencies must be able to withstand the heat of printing. Transparencies must meet the following conditions.

Criteria	Specifications
Heat resistance	Must withstand at least 190°C
Thickness	0.100 to 0.110 mm
Material	Polyester
Dimensional accuracy	±0.7 mm
Squareness of corners	90° ±0.2°

To avoid problems, use the multi purpose tray for transparencies and load transparencies with the long side facing the machine.

If transparencies jam frequently at output, try pulling the leading edge of sheets gently as they are ejected.

Cardstock

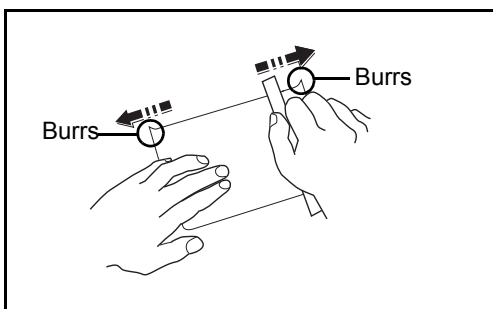

Before loading Hagaki into the multi purpose tray, fan them and align the edges. If the Hagaki paper is curled, straighten it before loading. Printing onto curled Hagaki may cause jams.

Use unfolded Oufuku Hagaki (available at post offices). Some Hagaki may still have rough edges developed by a paper cutter on the back side. Remove any such rough edges by placing the Hagaki on a flat surface and rubbing the edges gently a few times with a ruler.

Envelopes

Use the multi purpose tray for envelopes.

Due to the structure of envelopes, printing evenly over the entire surface may not be possible in some cases. Thin envelopes in particular may be wrinkled by the machine in some cases as they pass through. Before purchasing envelopes in volume, try testing a sample to ensure the print quality.

Storing envelopes for a long period may cause them to become wrinkled. Thus, keep the package sealed until you are ready to use them.

Keep the following points in mind.

Do not use envelopes with exposed adhesive. In addition, do not use the type of envelope in which the adhesive is exposed after the top layer is peeled off. Serious damage may be caused if the paper covering the adhesive comes off in the machine.

Do not use envelopes with certain special features. For example, do not use envelopes with a grommet for winding a string to close the flap or envelopes with an open or film-covered window.

If paper jams occur, load fewer envelopes at once.

To prevent paper jams when printing onto multiple envelopes, do not allow more than ten envelopes remain in the top tray at once.

Thick Paper

Before loading thick paper in the multi purpose tray, fan it and align the edges. Some thick paper may still have rough edges developed by a paper cutter on the back side. Remove any such rough edges just as with Hagaki by placing the paper on a flat surface and rubbing the edges gently a few times with a ruler. Printing onto paper with rough edges may cause jams.

NOTE: If the paper is not supplied correctly even after it is smoothed, load the paper in the multi purpose tray with the leading edge raised a few millimeters.

Label

Be sure to feed labels from the multi purpose tray.

For selecting labels, use extreme care so that the adhesive may not come in direct contact with any part of the machine and that the labels are not easily peeled from the carrier sheet. Adhesives that stick to the drum or rollers and peeled labels remaining in the machine may cause a failure.

When printing onto labels, you must be liable for the print quality and possible trouble.

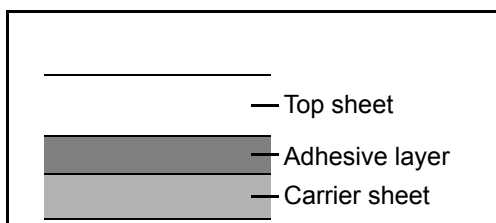

Labels consist of three layers as shown in the illustration. The adhesive layer contains materials that are easily affected by the force applied in the machine. The carrier sheet bears the top sheet until the label is used. This composition of labels may cause more problems.

The label surface must be covered completely with the top sheet. Gaps between labels may cause peeling of labels, resulting in a serious failure.

Some label paper has large margins on the top sheet. When using such paper, do not peel these margins from the carrier sheet before completing output.

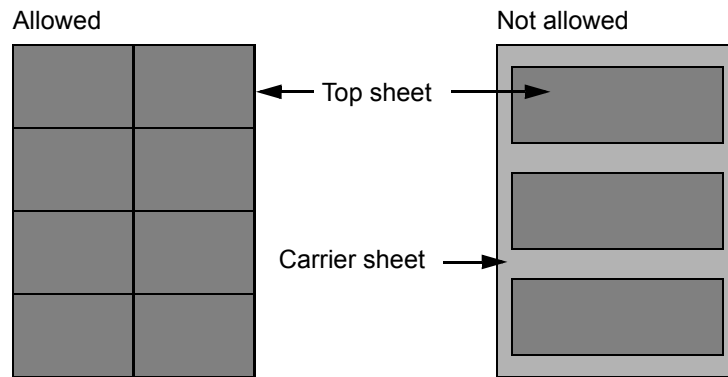

Use label paper that conforms to the following specifications.

Item	Specifications
Top sheet weight	44 to 74 g/m ²
Basis weight (overall paper weight)	104 to 151 g/m ²
Top sheet thickness	0.086 to 0.107 mm
Overall paper thickness	0.115 to 0.145 mm
Moisture content	4 to 6 % (composite)

Colored Paper

Colored paper must conform to the specifications listed on the page 11 of the Appendix. In addition, the pigments in the paper must be able to withstand the heat of printing (up to 200°C or 392°F).

Preprinted Paper

Preprinted paper must conform to the specifications listed on the page 9 of the Appendix. The colored ink must be able to withstand the heat of printing. It must be resistant to silicone oil as well. Do not use paper with a treated surface such as glossy paper used for calendars.

Recycled Paper

Recycled paper must conform to the specifications listed on the page 11 of the Appendix; however, its whiteness may be considered separately.

NOTE: Before purchasing recycled paper in volume, try testing a sample to ensure that the print quality.

Specifications

NOTE: Specifications are subject to change without notice.

Machine

Item	Description	
	FS-1028MFP	FS-1128MFP
Type	Desktop	
Printing Method	Electrophotography by semiconductor laser, single drum system	
Supported Original Types	Sheet, Book, 3-dimensional objects (maximum original size: Folio/Legal)	
Original Feed System	Fixed	
Paper Weight	Front Cassette	60 to 120 g/m ² (Duplex: 60 to 120 g/m ²)
	Multi Purpose Tray	60 to 220 g/m ² , 230 µm (Cardstock)
Paper Type	Front Cassette	Plain, Rough, Recycled, Preprinted, Bond, Color (Colour), Prepunched, Letterhead, High Quality, Custom 1 to 8 (Duplex: Same as Simplex)
	Multi Purpose Tray	Plain, Transparency (OHP film), Rough, Vellum, Labels, Recycled, Preprinted, Bond, Cardstock, Color (Colour), Prepunched, Letterhead, Thick, Envelope, High Quality, Custom 1 to 8
Paper Size	Front Cassette	Maximum: 8 1/2 × 14"/A4 (Duplex: 8 1/2 × 14"/A4) Minimum: 5 1/2 × 8 1/2"/A6 (Duplex: 7 1/4 × 10 1/2"/A5)
	Multi Purpose Tray	Maximum: 8 1/2 × 14"/A4 Minimum: 3 5/8 × 6 1/2"/C5
Zoom Level	Manual mode: 25 to 400%, 1% increments Fixed magnifications: 400%, 200%, 141%, 129%, 115%, 90%, 86%, 78%, 70%, 64%, 50%, 25%	
Printing Speed	Simplex	A4R/LetterR: 28/30 sheets/min Legal: 24 sheets/min B5R: 22 sheets/min A5R/A6R: 17 sheets/min
	Duplex	A4R/LetterR: 14/15 sheets/min Legal: 12 sheets/min
First Print Time (A4, feed from Cassette)	When using the document processor: 8.7 ± 0.5 seconds When the document processor is not used: 6.9 ± 0.5 seconds	
Warm-up Time (22°C/ 71.6°F,60%)	Power on	20 seconds
	Low Power	15 seconds
	Sleep	15 seconds

Item		Description	
		FS-1028MFP	FS-1128MFP
Paper Capacity	Front Cassette	250 sheets (80 g/m ²)	
	Multi Purpose Tray	50 sheets (80 g/m ² , plain paper, A4/Letter or less)	
Output Tray Capacity		150 sheets (80 g/m ²)	
Continuous Copying		1 to 999 sheets (can be set in one sheet increments)	
Image Write System		Semiconductor laser (1 beam)	
Main Memory		Standard: 256MB Maximum: 768MB	
Interface	Standard	USB Interface Connector: 1 (USB Hi-Speed) USB Host: 1 Network interface: 1 (10 BASE-T/100 BASE-TX)	
	Option	KUIO/W slot: 1	
Resolution		600 × 600 dpi	
Monthly Duty		Average: 1500pages Maximum: 20000pages	
Operating Environment	Temperature	10 to 32.5°C/50 to 90.5°F	
	Humidity	15 to 80 %	
	Altitude	8,200 feet/2,500 m or less	
	Brightness	1,500 lux or less	
Dimension (W × D × H)		19.4 × 16.1 × 14.4" 494 × 410 × 366 mm	19.4 × 16.9 × 17.6" 494 × 430 × 448 mm
Weight (without toner container)		33 lb/15 kg	40 lb/18 kg
Space Required (W × D)		25 3/16 × 25 7/16" 640 × 646 mm	
Power Requirement		120 V (60 Hz, more than 7.8 A) 220 to 240V (50/60 Hz, more than 4.0 A)	

Item		Description	
		FS-1028MFP	FS-1128MFP
Power Consumption	During printing	479.9 W (U.S.A./Canada), 470 W (European countries)	498 W (U.S.A./Canada), 484 W (European countries)
	During standby	83.8 W (U.S.A./Canada), 83.4 W (European countries)	91.8 W (U.S.A./Canada), 90 W (European countries)
	Low power mode	82.6 W (U.S.A./Canada), 82.3 W (European countries)	91.2 W (U.S.A./Canada), 90 W (European countries)
	Sleep mode	8.0 W (U.S.A./Canada), 8.8 W (European countries)	10.5 W (U.S.A./Canada), 11.1 W (European countries)
	Power off	0 W	
Options		Document processor, Paper feeder (up to 2 units)	

Printer

Item		Description
Printing Speed		Same as Copying Speed.
First Print Time (A4, feed from Cassette)		6.0 seconds or less
Resolution		Fine 1200, Fast 1200, 600 dpi, 300 dpi
Operating System		Windows 2000, Windows XP, Windows XP Professional, Windows Server 2003, Windows Server 2003 x64 Edition, Windows Vista x86 Edition, Windows Vista x64 Edition, Windows 2008 Server, Windows Server 2008 x64 Edition, Apple Macintosh OS 10.x
Interface	Standard	USB Interface Connector: 1 (USB Hi-Speed) USB Host: 1 Network interface: 1 (10 BASE-T/100 BASE-TX)
Page Description Language		PRESCRIBE

Scanner

Item	Description
Operating System	Windows 2000 (Service Pack 4), Windows XP, Windows Vista, Windows Server 2003, Windows Server 2008
System requirements	IBM PC/AT compatible CPU: Celeron 600Mhz or higher RAM: 128MB or more HDD free space: 20MB or more Interface: Ethernet
Resolution	600 dpi, 400 dpi, 300 dpi, 200 dpi
File Format	JPEG,TIFF,PDF, XPS
Scanning Speed	1-sided: B/W 20 Images/min Color 7 Images/min 2-sided: B/W 11 Images/min Color 4 Images/min (A4 landscape, 600 dpi, Image quality: Text/Photo original)
Interface	Ethernet (10 BASE-T/100 BASE-TX) USB2.0 (Hi-Speed USB)
Network Protocol	TCP/IP
Transmission System	PC transmission SMB Scan to SMB FTP Scan to FTP, FTP over SSL E-mail transmission SNMP Scan to E-mail TWAIN scan* ¹ WIA scan* ²

*1 Available Operating System : Windows 2000 (Service Pack 4), Windows XP, Windows Vista

*2 Available Operating System : Windows Vista

Document Processor (option)

Item	Description
Original Feed Method	Automatic feed
Supported Original Types	Sheet originals
Paper Size	Maximum: Legal/A4 Minimum: Statement/A5
Paper Weight	50 to 120 g/m ²
Loading Capacity	50 sheets (50 to 80 g/m ²) maximum
Dimensions (W) × (D) × (H)	22 3/4 × 21 × 7 1/8" 455 × 338 × 93 mm
Weight	3 kg or less

Environmental Specifications

Item	Description	
	FS-1028MFP	FS-1128MFP
Time to Low Power mode (default setting)	2 minutes	
Time to Sleep mode (default setting)	15 minutes	
Recovery time from Low Power mode	10 seconds or less	
Recovery time from Sleep mode	15 seconds or less	
Duplexing	Standard	
Paper supply capability	100% recycled paper may be used.	

NOTE: Consult your dealer or service representative for recommended paper types.

Glossary

AppleTalk

AppleTalk, which comes with Apple Computer's Mac OS, is a network protocol. AppleTalk enables file/printer sharing and also enables you to utilize application software that is on another computer on the same AppleTalk network.

Auto Form Feed Timeout

During data transmission, the machine may sometimes have to wait until receiving the next data. This is the auto form feed timeout. When the preset timeout passes, the machine automatically put paper out. However, no output is performed if the last page has no data to be printed.

Auto Paper Selection

A function to automatically select paper in the same size as original at printing

Auto Sleep Mode

A mode designed for electrical power saving, activated when the machine is left unused or data transfer for a specific period. In Sleep mode, power consumption is kept to a minimum.

Bonjour

Bonjour, also known as zero-configuration networking, is a service that automatically detects computers, devices and services on an IP network. Bonjour, because an industry-standard IP protocol is used, allows devices to automatically recognize each other without an IP address being specified or DNS server being set. Bonjour also sends and receives network packets by UDP port 5353. If a firewall is enabled, the user must check that UDP port 5353 is left open so that Bonjour will run correctly. Some firewalls are set up so as to reject only certain Bonjour packets. If Bonjour does not run stably, check the firewall settings and ensure that Bonjour is registered on the exceptions list and that Bonjour packets are accepted. If you install Bonjour on Windows XP Service Pack 2 or later, the Windows firewall will be set up correctly for Bonjour.

Default Gateway

This indicates the device, such as a computer or router, that serves as the entrance/exit (gateway) for accessing computers outside the network that you are on, When no specific gateway is designated for a destination IP address, data is sent to the host designated as the Default Gateway.

DHCP (Dynamic Host Configuration Protocol)

Dynamic Host Configuration Protocol (DHCP) that automatically resolves IP addresses, subnet masks, and gateway addresses on a TCP/IP network. DHCP minimizes the load of network management employing a large number of client computers because it relieves individual clients including printers from the IP address being assigned.

dpi(dots per inch)

A unit for resolution, representing the number of dots printed per inch (25.4 mm).

EcoPrint Mode

A printing mode that helps save toner. Copies made in this mode are thus lighter than normal.

Emulation

The function to interpret and execute other printers' page description languages. The machine emulates operation of PCL6, KPDL, and KPDL (automatic).

FTP(File Transfer Protocol)

A protocol to transfer files on the TCP/IP network, whether the Internet or an intranet. Along with HTTP and SMTP/POP, FTP is now frequently used on the Internet.

Grayscale

A computer color expression. Displayed images of this sort are typically composed of shades of gray, varying from black at the weakest intensity to white at the strongest, without any other colors. Gray levels are displayed in numerical levels: that is, white and black only for 1 bit; 256 gray levels (including white and black) for 8 bits; and 65,536 gray levels for 16 bits.

IP Address

An Internet protocol address is a unique number that represents a specific computer or related device on the network. The format of an IP address is four sets of numbers separated by dots, e.g. 192.168.110.171. Each number should be between 0 and 255.

IPP

IPP (Internet Printing Protocol) is a standard that uses TCP/IP networks such as the Internet to enable print jobs to be sent between remote computers and printers. IPP is an extension of the HTTP protocol used to view websites and enables printing to be carried out via routers on printers in remote locations. It also supports the HTTP authentication mechanisms along with SSL server and client authentication as well as encryption.

KPDL (Kyocera Page Description Language)

Kyocera's PostScript page description language compatible with Adobe PostScript Level 3.

Multi Purpose (MP) Tray

The paper supply tray on the right side of the machine. Use this tray instead of the cassettes when printing onto envelopes, Hagaki, transparencies, or labels.

NetBEUI (NetBIOS Extended User Interface)

An interface, developed by IBM in 1985, as an update from NetBIOS. It enables more advanced functions on smaller networks than other protocols such as TCP/IP, etc. It is not suitable for larger networks due to lack of routing capabilities to choose the most appropriate routes. NetBEUI has been adopted by IBM for its OS/2 and Microsoft for its Windows as a standard protocol for file sharing and printing services.

NetWare

Novell's network management software that is able to run on a variety of operating systems.

POP3 (Post Office Protocol 3)

A standard protocol to receive E-mail from the server in which the mail is stored on the Internet or an intranet.

PostScript

A page description language developed by Adobe Systems. It enables flexible font functions and highly-functional graphics, allowing higher quality printing. The first version called Level 1 was launched in 1985, followed by Level 2 that enabled color printing and two-byte languages (e.g. Japanese) in 1990. In 1996, Level 3 was released as an update for the Internet access and PDF format as well as gradual improvements in implementation technologies.

PPM (prints per minute)

This indicates the number of A4 size printouts made in one minute.

Printer Driver

The software to enable you to print data created on any application software. The printer driver for the machine is contained in the CD-ROM enclosed in the package. Install the printer driver on the computer connected to the machine.

Send as E-mail

A function to send the image data stored in the machine as an E-mail attachment. E-mail addresses can be selected from the list or entered at each time.

SMTP (Simple Mail Transfer Protocol)

A protocol for E-mail transmission over the Internet or an intranet. It is used for transferring mail between mail servers as well as for sending mail from clients to their servers.

Status Page

The page lists machine conditions, such as the memory capacity, total number of prints and scans, and paper source settings.

Subnet Mask

The subnet mask is a way of augmenting the network address section of an IP address. A subnet mask represents all network address sections as 1 and all host address sections as 0. The number of bits in the prefix indicates the length of the network address. The term "prefix" refers to something added to the beginning and, in this context, indicates the first section of the IP address. When an IP address is written, the length of the network address can be indicated by the prefix length after a forward slash (/). For example, "24" in the address "133.210.2.0/24". In this way, "133.210.2.0/24" denotes the IP address "133.210.2.0" with a 24-bit prefix (network section). This new network address section (originally part of the host address) made possible by the subnet mask is referred to as the subnet address. When you enter the subnet mask, be sure to set the *DHCP* setting to *Off*.

TCP/IP (Transmission Control Protocol/Internet Protocol)

TCP/IP is a suite of protocols designed to define the way computers and other devices communicate with each other over a network.

TCP/IP (IPv6)

TCP/IP (IPv6) is based on the current Internet protocol, TCP/IP (IPv4). IPv6 is the next-generation Internet protocol and expands the available address space, which resolves the problem of the lack of addresses under IPv4, while also introducing other improvements such as additional security functionality and the capacity to prioritize data transmission.

TWAIN (Technology Without Any Interested Name)

A technical specification for connecting scanners, digital cameras, and other image equipment to the computers. The TWAIN compatible devices enable to process image data on any relevant application software. TWAIN is adopted on a large number of graphic software (e.g. Adobe Photoshop) and OCR software.

USB (Universal Serial Bus)2.0

A USB interface standard for Hi-Speed USB 2.0. The maximum transfer rate is 480 Mbps. This machine is equipped with USB 2.0 for high-speed data transfer.

WIA (Windows Imaging Acquisition)

A function to import images supported after Windows Me/XP from digital cameras and other peripheral devices. This function replaces what TWAIN used to do; the feature is provided as a part of Windows functions and improves ease of operation, so that you import images directly to My Computer without using any application.

Index

Numerics

1-sided/2-sided Selection **5-7**

A

Accessibility **Appendix-23**

Adjusting Density **5-13**

Auto **3-10**

Manual **3-10**

Adjustment/Maintenance **8-87**

Copy Density Adjustment **8-87**

Correcting Fine Black Lines **8-89**

Developer Refresh **8-90**

Send/Box Density **8-88**

AppleTalk **Appendix-23**

Setup **2-22**

Auto Low Power Mode **3-4**

Auto Paper Selection **Appendix-23**

Auto Sleep **3-5, Appendix-23**

B

Bonjour **Appendix-23**

Bundled Items **2-2**

Buzzer **8-6**

C

Cassette

Loading Paper **2-29**

Paper Size and Media Type **8-13**

CD-ROM **2-2**

Changing Language **2-7, 8-2**

Cleaning

Separator **9-5**

Slit Glass **9-2**

Color

Color / Grayscale / Black and White Selection **5-15**

Color mode

Color Selection (Copy) **8-34**

Combine Mode

2-in-1 Mode **4-11**

4-in-1 Mode **4-12**

Page Boundary Lines **4-13**

COMMAND CENTER **2-25**

Connecting

LAN Cable **2-5**

Power Cable **2-7**

USB Cable **2-7**

Connection Method **2-3**

Continuous Scan

Copy **4-15**

Send **5-16**

Copy

Adjusting Density **3-10**

Collate Copying **3-17**

Duplex Copying **3-14**

Offset Copying **3-17**

Originals **4-2**

Selecting Image Quality **3-11**

Setup **8-56**

Zoom Copying **3-12**

Copy Settings **8-56**

Auto Paper Selection **8-58**

Paper Selection **8-57**

Quick Setup Registration **8-60**

Copying Functions **4-1**

Counting the Number of Pages Printed

Each Job **11-32**

Printing a Report **11-35**

Total Job **11-30**

Counting the Number of Pages Printed **11-30**

D

Date/Timer **8-92**

Auto Panel Reset **8-106**

Date Format **8-95**

Date/Time **8-92**

Low Power Timer **8-108**

Time Zone **8-97**

Default **8-30**

Collate/Offset **8-42**

Color Selection (Copy) **8-34**

Continuous Scan **8-31**

Density **8-37**

EcoPrint **8-43**

E-mail Subject/Body **8-40**

- File Format **8-36**
- File Name **8-39**
- Original Image **8-32**
- Original Orientation **8-30**
- Scan Resolution **8-33**
- Zoom **8-38**
- Default Gateway **Appendix-23**
- Default Screen **8-5**
- Density Adjustment
 - Copy **3-10**
 - Send **5-13**
- Destination **8-112**
 - Adding **8-112**
 - Adding a Group **8-118**
 - Choosing by One-Touch Key **3-30**
 - Choosing from the Address Book **3-28**
 - Editing **8-122**
 - One-touch Key **8-124**
 - Search **3-28**
 - Sending to Different Types of Destinations (Multi Sending) **3-30**
- Device **7-20**
 - Checking Status **7-20**
 - Configuring **7-21**
- DHCP **Appendix-23**
- Document Box **6-1**
 - Quick Setup Registration **8-66**
- Document Processor **Appendix-2, Appendix-22**
 - How to Load Originals **2-46**
 - Loading Originals **2-45**
 - Not Supported Originals **2-45**
 - Part Names **2-45**
 - Supported Originals **2-45**
- dpi **Appendix-23**
- Duplex **3-14, 8-74**

E

- EcoPrint Mode **Appendix-24**
 - Copy **4-10**
 - Print **8-72**
- E-mail
 - Send as E-mail **3-21**
- Emulation **Appendix-24**
 - Selection **8-69**

- Enter E-mail Subject and Body **5-18**
- Entry
 - Body **5-18**
 - File Name **4-18, 5-17**
 - Subject **5-18**
- Error Handling **8-28**
- Error Messages **10-5**
- Expansion Memory **Appendix-2**

F

- File
 - Format **5-10**
- File Name **4-18**
- FTP **Appendix-24**
- FTP Encrypted TX **5-23, 5-24**

G

- Grayscale **5-15, Appendix-24**

I

- Image Quality
 - Copy **3-9**
 - Send **5-12**
- Interface Block **8-146**
- IP Address **Appendix-24**
- IPP **Appendix-24**

J

- Job
 - Available Status **7-2**
 - Canceling **3-31, 7-19**
 - Checking History **7-8**
 - Checking Status **7-2**
 - Pause and Resumption **7-19**
 - Sending the Job Log History **7-13**
- Job Accounting **11-13**
 - Managing the Copier/Printer Counts **11-20**
 - Restricting the Use of the Machine **11-22**
- Job Finish Notice **5-21**
 - Copy **4-16**
 - Send **5-21**

K

KPDL **Appendix-24**

L

Label **Appendix-16**

LAN Cable

Connecting **2-5**

Login **3-6, 11-5**

Logout **3-6, 11-5**

Low Power Mode **3-5**

Low Power Timer **8-108**

M

Management **11-1**

Job Accounting **11-13**

User Login Administration **11-2**

Multi Purpose (MP) Tray **Appendix-24**

Paper Size and Media **2-41, 8-15**

Multi Sending (Sending to Different Types of Destinations) **3-30**

N

NetBEUI **Appendix-24**

NetWare **8-130, Appendix-24**

Setup **8-130**

Network

Setup **2-12**

Network Cable **2-4**

Connecting **2-5**

Network Interface **2-4**

Network Security **8-138**

Network Setup

AppleTalk **2-22**

FTP (Reception) **8-135**

HTTP **8-135**

HTTPS **8-135**

IPP over SSL **8-136**

LAN Interface **8-128**

LDAP **8-135**

LPD **8-135**

NetBEUI **8-135**

NetWare **8-130**

POP3 (E-mail RX) **8-135**

Raw Port **8-135**

SMTP (E-mail TX) **8-135**

SNMP **8-135**

TCP/IP (IPv4) **8-129**

TCP/IP (IPv6) **8-129, 8-132, 8-133**

O

Operation Panel **1-2**

Option

Document Processor **Appendix-2**

Expansion Memory **Appendix-2**

Overview **Appendix-2**

Paper Feeder **Appendix-2**

Optional Functions **8-151**

Original

Loading in the Document
Processor **2-45**

Placing on the Platen **2-44**

Original Orientation

Copy **4-8**

Document Processor **4-8**

Send **5-8**

Original Size Indicator Plates **2-44**

Original Size Selection

Send **5-2**

Originals

Copy **4-2**

Custom **8-8**

Setup **8-8**

Size Selection **4-2, 5-2**

P

Paper

Appropriate Paper **Appendix-12**

Auto Selection **8-23**

Before Loading **2-28**

Cassette **8-13**

Custom **8-11**

Default Paper Source **8-22**

Loading Envelopes **2-34**

Loading in the Cassettes **2-29**

Loading in the Multi Purpose Tray **2-32**

Multi Purpose Tray **8-15**

Setup **8-8**

Size and Media **2-38, Appendix-9**

Special Paper **8-24, Appendix-14**
Specifications **Appendix-11**
Weight **8-17**
Paper Feeder **Appendix-2**
Paper Jam **10-11**
 Cassette 1 **10-12**
 Cassette 2 **10-12**
 Document Processor **10-16**
 Inside the Left Covers 1, 2 and 3 **10-15**
 Jam Location Indicators **10-11**
 Multi Purpose Tray **10-15**
 Precaution **10-11**
Paper Selection **4-4**
 Cassette **4-4**
 Multi Purpose Tray **4-5**
Part Names **1-1**
Platen
 Placing Originals **2-44**
POP3 **Appendix-25**
PostScript **Appendix-25**
Power Cable
 Connecting **2-7**
Power Off **3-3**
Power On **3-2**
PPM **Appendix-25**
Preparation **2-1**
Preparing Cables **2-4**
Printer
 Setup **8-69**
Printer Driver **Appendix-25**
Printer Settings **8-69**
 Copies **8-75**
 CR Action **8-78**
 Duplex **8-74**
 EcoPrint **8-72**
 Emulation **8-69**
 Form Feed Timeout **8-77**
 LF Action **8-77**
 Orientation **8-76**
 Override A4/Letter **8-73**
Printing **3-18**
Printing from Applications **3-18**
Printing Reports/Sending Notice **8-81**
 Font List **8-82**
 Network Status Page **8-83**
 Service Status Page **8-83**

Status Page **8-81**
Transmission Result Reports **8-85**
Product Library **2-2**

Q

Quick Setup Screen
 Changing Registration **8-60, 8-62, 8-66**

R

Replacement
 Toner Container **9-5**
 Waste Toner Box **9-5**
Resolution **Appendix-19, Appendix-20**
Restarting the System **8-127**

S

Scan Resolution **5-14**
 Default settings **8-33**
Send
 File Format **5-10**
 Image Quality **5-12**
 Original Size Selection **5-2**
 Sending Size Selection **5-4**
 Setup **8-62**
Sending
 Send as E-mail **3-21**
 Send to Folder (FTP) **3-25**
 Send to Folder (SMB) **3-25**
Sending E-mail **2-26**
Sending Functions **5-1**
Sending Settings **8-62**
 Quick Setup Registration **8-62**
Sending Size Selection **5-4**
Sending to Different Types of Destinations
(Multi Sending) **3-30**
Separator
 Cleaning **9-5**
Setting Date and Time **2-9**
Setup
 AppleTalk **2-22**
 Copy **8-56**
 Date/Timer **8-92**
 NetWare **8-130**
 Network **8-128**

Printer **8-69**
Send **8-62**
Sleep **3-5**
Slit Glass
Cleaning **9-2**
SMTP **Appendix-25**
Solving Malfunctions **10-2**
Specifications
Document Processor **Appendix-22**
Environmental Specifications **Appendix-22**
Machine **Appendix-18**
Printer **Appendix-20**
Scanner **Appendix-21**
Specifying Destination **3-28**
Status / Job Cancel **7-1**
Status Page **8-81, Appendix-25**
Subnet Mask **Appendix-25**
Switching the Language **2-7, 8-2**
Switching Unit of Measurement **8-27**
System Menu **8-1**

T

TCP/IP **Appendix-25**
Toner Container
Replacement **9-5**
TWAIN **Appendix-26**

U

Unusable Time **8-109**
USB **Appendix-26**
USB Cable
Connecting **2-7**
USB Interface **2-4**
USB Memory

Printing Documents **6-2**
Removing **6-6**
Saving Documents **6-4**
User Login Administration **11-2**
Adding **11-6**
Changing Properties **11-9**
Enabling/Disabling **11-2**
Login **11-5**
Logout **11-5**
Unknown login user name Job **11-11**

W

Waste Toner Box
Replacement **9-5**
WIA **Appendix-26**
WSD Scan **5-19**

X

XPS
File formats **5-10, 8-36**
Printing documents stored in Removable USB Memory **6-2**
Saving documents to Removable USB Memory **6-4**

Z

Zoom Copying
Auto Zoom **3-12**
Manual Zoom **3-12**
Preset Zoom **3-12**
Zoom Mode
Copy **3-12, 5-6**
Send **5-6**



PASSIONATE PEOPLE. FROM ALL OVER THE WORLD.



KYOCERA MITA EUROPE B.V.



EUROPEAN HEADQUARTERS
Bloemlaan 4
2132 NP Hoofddorp
The Netherlands
Phone: +31 20 654 0000
Fax: +31 20 653 1256
www.kyoceramita-europe.com



KYOCERA MITA Europe B.V.,
Amsterdam (NL)
Zweigniederlassung Zürich
Hohlstrasse 614
CH-8048 Zürich
Phone: +41 1 908 49 49
Fax: +41 1 908 49 50
www.kyoceramita.ch

KYOCERA MITA SALES COMPANIES IN EMEA



KYOCERA MITA INTERNATIONAL SALES
(Europe, Middle East & North Africa)
Bloemlaan 4
2132 NP Hoofddorp
The Netherlands
Phone: +31 20 654 0000
Fax: +31 20 653 1256
www.kyoceramita-europe.com



AUSTRIA
KYOCERA MITA AUSTRIA GmbH
Eduard Kittenberger Gasse 95
A-1230 Wien
Phone: +43 1 86 338 0
Fax: +43 1 86 338 400
www.kyoceramita.at



BELGIUM
S.A. KYOCERA MITA Belgium N.V.
Sint-Martinusweg 199-201
BE-1930 Zaventem
Phone: +32 2 720 9270
Fax: +32 2 720 8748
www.kyoceramita.be



DENMARK
KYOCERA MITA Denmark A/S
Ejby Industrivej 1
DK-2600 Glostrup
Phone: +45 70 22 3880
Fax: +45 45 76 3850
www.kyoceramita.dk



FINLAND
KYOCERA MITA Finland OY
Kirvesmiehenkatu 4
FI-00880 Helsinki
Phone: +358 9 4780 5200
Fax: +358 9 4780 5390
www.kyoceramita.fi



FRANCE
KYOCERA MITA France S.A.
Parc les Algorithmes Saint Aubin
FR-91194 Gif-Sur-Yvette
Phone: +33 1 6985 2600
Fax: +33 1 6985 3409
www.kyoceramita.fr



GERMANY
KYOCERA MITA Deutschland GmbH
Otto-Hahn-Str. 12
D-40670 Meerbusch / Germany
Phone: +49 2159 918 0
Fax: +49 2159 918 100
www.kyoceramita.de



ITALY
KYOCERA MITA Italia S.P.A.
Via Verdi, 89/91
I-20063 Cernusco sul Naviglio (MI)
Phone: +39 02 921 791
Fax: +39 02 921 796 00
www.kyoceramita.it



THE NETHERLANDS
KYOCERA MITA Nederland B.V.
Beechavenue 25
1119 RA Schiphol-Rijk
Phone: +31 20 587 7200
Fax: +31 20 587 7260
www.kyoceramita.nl



NORWAY
KYOCERA MITA Norge
Olaf Helsetsvai 6
NO-0694 Oslo
Phone: +47 22 627 300
Fax: +47 22 627 200
www.kyoceramitanorge.no



PORTUGAL
KYOCERA MITA Portugal LDA.
Rua do Centro Cultural 41
PT-1700-106 Lisboa
Phone: +351 21 843 6780
Fax: +351 21 849 3312
www.kyoceramita.pt



SOUTH AFRICA
KYOCERA MITA South Africa (Pty) Ltd.
527 Kyalami Boulevard, Kyalami
Business Park · ZA-1685 Midrand
Phone: +27 11 540 2600
Fax: +27 11 466 3050
www.kyoceramita.co.za



SPAIN
KYOCERA MITA España S.A.
Avda. Manacor No. 2
ES-28290 Las Matas (Madrid)
Phone: +34 91 631 83 92
Fax: +34 91 631 82 19
www.kyoceramita.es



SWEDEN
KYOCERA MITA Svenska AB
Esbogatan 16B
SE-164 75 Kista
Phone: +46 8 546 550 00
Fax: +46 8 546 550 10
www.kyoceramita.se



UNITED KINGDOM
KYOCERA MITA UK Ltd.
8 Beacontree Plaza, Gillette Way,
Reading, Berkshire RG2 OBS
Phone: +44 1189 311 500
Fax: +44 1189 311 108
www.kyoceramita.co.uk

KYOCERA MITA WORLDWIDE



JAPAN
KYOCERA MITA Corporation
(Head Office)
2-28, 1-Chome, Tamatsukuri, Chuo-ku,
Osaka 540-8585, Japan
Phone: +81 6 6764 3555
Fax: +81 6 6764 3980
www.kyoceramita.com



USA
KYOCERA MITA America, INC.
(Head office)
225 Sand Road, P.O. Box 40008
Fairfield, New Jersey 07004-0008, USA
Phone: +1 973 808 8444
Fax: +1 973 882 6000
www.kyoceramita.com/us

KYOCERA CORPORATION



JAPAN
KYOCERA CORPORATION
(Corporate Headquarters)
6 Takeda Tobadono-cho, Fushimi-ku
Kyoto 612-8501, Japan
Phone: +81 75 604 3500
Fax: +81 75 604 3501
www.kyocera.co.jp

 **KYOCERA**

