

**Installation Manual for Kyocera iBurst System
(BS1905A-US-A)**

April 26, 2004

Revision 1.00

Doc-No. Q05T-AI-BB001E

Kyocera Corp.

2-1-1 Kagahara, Tsuzuki-ku, Yokohama-city, Kanagawa 224-8502, Japan
Telephone:+81-45-943-6176
Fax:+81-45-943-6123

© KYOCERA Corporation 2003
All right reserved.

No part of this publication may be excerpted, reproduced,
translated or edited, in any form by any means, without
the prior written permission of KYOCERA Corporation

Approved	Checked	Checked	Prepared

Revision History

Revision	Description	Date	Charge
1.00	1st Edition	April 26, 2004	Y. Izawa

- 1. INSTALLATION CRITERIA..... 5**
- 1.1 PURPOSE AND POLICY..... 6
- 1.2 LAWS 6
- 1.3 PRECAUTIONS FOR HANDLING 6
- 1.4 DESIGN AND EXECUTION POLICY 6
- 1.5 INSTALLATION CRITERIA..... 6
 - 1.5.1 *General*..... 6
 - 1.5.2 *Criteria for selecting antenna location* 8
 - 1.5.2.1 Accuracy of antenna mounting 8
 - 1.5.2.2 Sequence of mounting antenna..... 8
 - 1.5.2.3 Interval of antenna..... 8
 - 1.5.2.4 Lightening protection..... 9
 - 1.5.2.5 Isolation from drain..... 9
 - 1.5.2.6 Isolation from obstacle 10
 - 1.5.2.7 Horizontal sight angle..... 10
 - 1.5.2.8 Vertical sight angle..... 11
 - 1.5.2.9 Isolation from radio system..... 12
 - 1.5.2.10 Isolation from outdoor unit of air conditioner, etc. 14
 - 1.5.2.11 Isolation from power line 14
 - 1.5.3 *Criteria for selecting PA unit location* 15
 - 1.5.3.1 Mounting direction of PA unit..... 15
 - 1.5.3.2 Securing space for PA unit 15
 - 1.5.3.3 Lightening protection..... 16
 - 1.5.3.4 Isolation from drain..... 17
 - 1.5.4 *Criteria for selecting GPS unit location* 17
 - 1.5.4.1 Accuracy of GPS mounting..... 17
 - 1.5.4.2 GPS sight space 18
 - 1.5.4.3 Lightening protection for GPS..... 19
 - 1.5.5 *Criteria for selecting Base unit location*..... 20
 - 1.5.5.1 Installation space for Base unit..... 20
 - 1.5.5.2 Lightening protection for Base unit..... 20
 - 1.5.5.3 Isolation from drain..... 21
 - 1.5.5.4 Isolation from iBurst antenna 21
 - 1.5.6 *Precautions on cabling* 22
 - 1.5.6.1 Ground 22
 - 1.5.6.2 Cable 22
 - 1.5.7 *Precautions in installation on the roof*..... 23

1.5.8	<i>Separation of power systems</i>	24
1.5.9	<i>Waterproof treatment for connector and bushing</i>	25
2	CONFIGURATION OF BASE STATION AND ACCESSORIES	26
2.1	CONFIGURATION OF BASE STATION.....	27
2.1.1	<i>System Diagram</i>	27
2.1.1.1	Star connection.....	27
2.1.1.2	Daisy-chain connection.....	28
2.1.2	<i>Appearance form</i>	29
2.1.2.1	PA unit.....	29
2.1.2.2	Inside LID.....	30
2.1.2.3	GPS unit.....	31
2.1.2.4	Base unit.....	32
2.1.3	<i>Connection diagram</i>	37
2.1.3.1	PA unit - Antenna.....	37
2.1.3.2	PA unit-Base unit.....	38
2.1.3.3	Base unit – Other equipment.....	42
2.1.4	<i>Pin assignment of cables/connectors</i>	43
2.1.4.1	AC Power supply cable.....	43
2.1.4.2	PA control cable.....	43
2.1.4.3	Network cable.....	44
2.1.4.4	GPS cable.....	44
2.1.4.5	GPI cable.....	45
2.1.4.6	Master/Slave cable.....	45
2.2	SPECIFICATIONS.....	46
2.2.1	<i>Hardware specifications</i>	46
2.2.2	<i>LED indicators</i>	47
2.2.2.1	PA unit.....	47
2.2.2.2	Base unit.....	47
2.2.3	<i>Accessories</i>	48
2.2.3.1	PA unit.....	48
2.2.3.2	Base unit.....	48
2.2.4	<i>Cable specification</i>	48
2.2.5	<i>Other Parts specification</i>	49
2.2.6	<i>Handling of cables</i>	50
2.2.7	<i>Tightening Torque</i>	50
2.2.8	<i>Tools</i>	51
3	INSTALLATION	52
3.1	INSTALLING ANTENNA SYSTEM (EXAMPLE).....	53
3.1.1	<i>Installing the antenna pole</i>	53
3.2	INSTALLING PA UNIT.....	56
3.2.1	<i>Mounting and removing the Eyebolt</i>	56
3.2.2	<i>Mounting the PA Unit (Example)</i>	57
3.2.3	<i>Connecting cables</i>	59
3.2.3.1	Connecting the AC power supply cable.....	59
3.2.3.2	Connecting the grounding cable.....	64
3.2.3.3	Connecting the PA control cable.....	65
3.2.3.4	Connecting the antenna cable.....	70
3.2.3.5	Connecting the Calibration cable.....	72
3.2.3.6	Connecting the PU-BU RF cable.....	79
3.3	INSTALLING THE GPS UNIT.....	82
3.4	INSTALLING THE BASE UNIT.....	86
3.4.1	<i>Mounting and removing the Eyebolt</i>	86
3.4.2	<i>Fixing the Base Unit</i>	88
3.4.3	<i>Connecting cables</i>	89

3.4.3.1	Connecting the AC power supply cable	89
3.4.3.2	Fixing the grounding cable	94
3.4.3.3	Connecting the PA control cable	95
3.4.3.4	Connecting the GPS cable	100
3.4.3.5	Connecting the Calibration cable	105
3.4.3.6	Connecting the PU-BU RF cable	110
3.4.3.7	Connecting the Network cable	114
3.4.3.8	Connecting the Master/Slave cable	123
3.4.3.9	Attachment of Grounding Kit	130
3.4.4	<i>Inserting the board</i>	130
3.4.4.1	Notes at setting Boards and Power supply	131
3.4.4.2	Inserting the Power supply	133
3.4.4.3	Inserting the LoCal board	133
3.4.4.4	Inserting the MoNerd board	134
3.4.4.5	Inserting the TRx board	134
3.4.4.6	Inserting the FAN tray	134
3.4.4.7	Removing the Power supply and other boards	135
3.4.5	<i>Connecting cables to the Power supply and boards</i>	136
3.4.5.1	Power supply	136
3.4.5.2	LoCal board	137
3.4.5.3	MoNerd board	137
3.4.5.4	TRx the board	138

* iBurst is the trademark of ArrayComm.

* All the things in which a size does not have a unit display are mm units.

1. Installation Criteria

1.1 Purpose and policy

This document is intended to specify a fundamental design criterion for the installation of iBurst base station, thus ensuring smooth work and providing the customer with appropriate services and establishing easy-to-maintain system.

1.2 Laws

In executing the work, necessary related laws (Telecommunications Business Law, Wired Telecommunications Law, Radio Law, Building Standard Law, Electric Work Specialist Law, Fire Fighting Law, etc. in Japan), other related laws, and licensing conditions must be observed. In addition, application for permission based on the law must be conducted without delay.

1.3 Precautions for handling

The iBurst system contains precision components; therefore, do not give any strong shock by falling or dropping.

Strong shock may result in a failure or badly affect the lifetime or the product.

1.4 Design and execution policy

1.4.1 In designing the work, functionality, reliability, maintainability, economy, etc. must be fully taken into account.

1.4.2 Not only enhancement of safety mind but also security for the third party must always be kept in mind.

1.4.3 Be sure to make efforts to complete better work objective in accordance with technological sense.

1.4.4 Be sure to keep communication with the owner and residents of the building and the neighboring residents with due consideration not to cause a problem.

1.4.5 Be sure to make efforts to grasp the status of the work, to give an appropriate advice, and to fulfill a duty of reporting the status.

1.4.6 Be sure to prevent the work from generating a noise or vibration to maintain the living environment.

1.4.7 Be sure to dispose the waste materials caused from the work in accordance with the specified method regarding the method, place, etc. of disposal, thereby preventing the occurrence of accident to be caused by the waste material.

1.4.8 In conducting a negotiation or design, future expansion of equipment should be considered as much as possible.

1.5 Installation criteria

1.5.1 General

1.5.1.1 Select the location where general public is hard to access but maintenance is easy.

1.5.1.2 Antenna and mounting stud must be located at a place where dropping or other accident, if any, may not be harmful for the personnel and general public.

1.5.1.3 In designing a base station, the location shall be determined by the study of strength against load and work product.

- 1.5.1.4 Do not place antenna, base station, or other obstruction in front of advertising display such as neon sign and signboard.
- 1.5.1.5 When conducting the work, select the location of antenna, base station, UPS, wiring, piping, etc. in consultation with the owner while considering the appearance.
- 1.5.1.6 Before implementing the work, check the status of any broken or damaged portion of the building and facilities associated with the installation area of the base station together with the owner or the person from the control company.
- 1.5.1.7 Materials for mounting equipment
 - 1.5.1.7.1 ~~Quality-of-the-material~~ specification used for the mount of outdoor installation etc. is considered as hot-dip galvanized. Moreover, ~~quality-of-the-material~~ specification of inside-of-a-house installation is made into the anti-rust material more than electric zinc plating material, and a bolt and a nut also apply to this. However, about the place of conditions, which are easy to generate, such as rust etc., it applies to outdoor specification.
However, a hot-dip galvanized steel or Dacrotized finishing is recommended for the bolt directly fixed on PA unit mounting bracket.
 - 1.5.1.7.2 In the connection of various cables, use of cold-shrinkable tube as well as self-fusing tape is recommended as a method of waterproof treatment.
- 1.5.1.8 Study the shape of the building and the status of waterproof treatment on the roof not to cause any problem in the installation on the building.

1.5.2 Criteria for selecting antenna location

1.5.2.1 Accuracy of antenna mounting

Antenna shall basically be installed vertically within the range of ± 2 degrees off the vertical line.

1.5.2.2 Sequence of mounting antenna

Each PA unit to be connected with the antenna has antenna numbers (ANT1 to ANT3). The location of ANT1 is not specified specifically.

1.5.2.3 Interval of antenna

Antennas shall be separated by more than 3λ from each other as shown below. An average interval of antenna shall be separated by more than 8λ .

Frequency	Isolation (L)
1.9GHz	More than 50cm

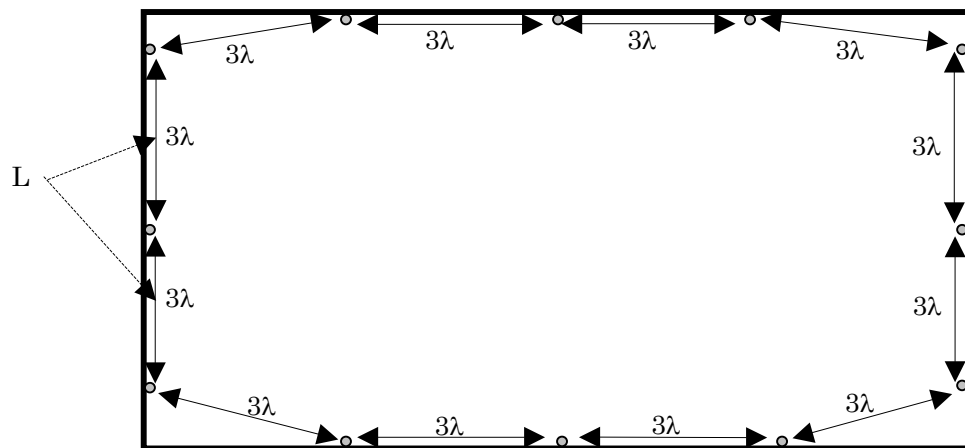
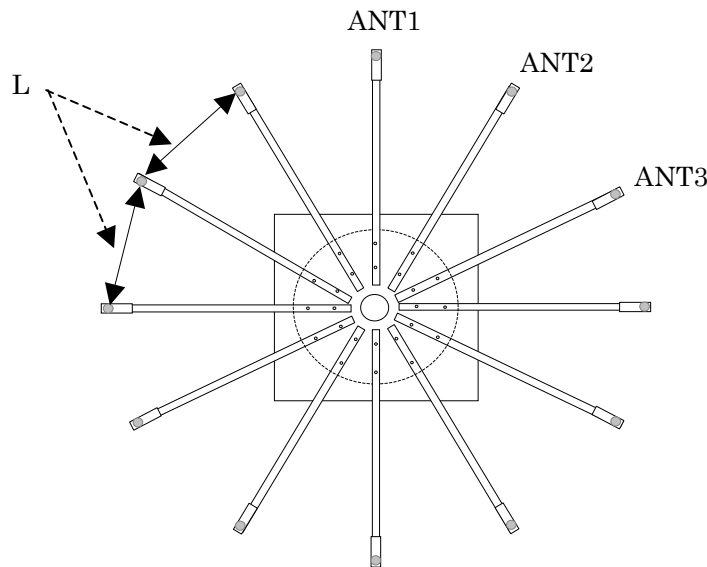

Sequence of antenna mounting and interval of antennas

1.5.2.4 Lightning protection

Antenna installation shall be designed to be within the protection angle (* 60 degrees) of the lightning rod.

* Lightning protection method is obeying the law by State regulations.

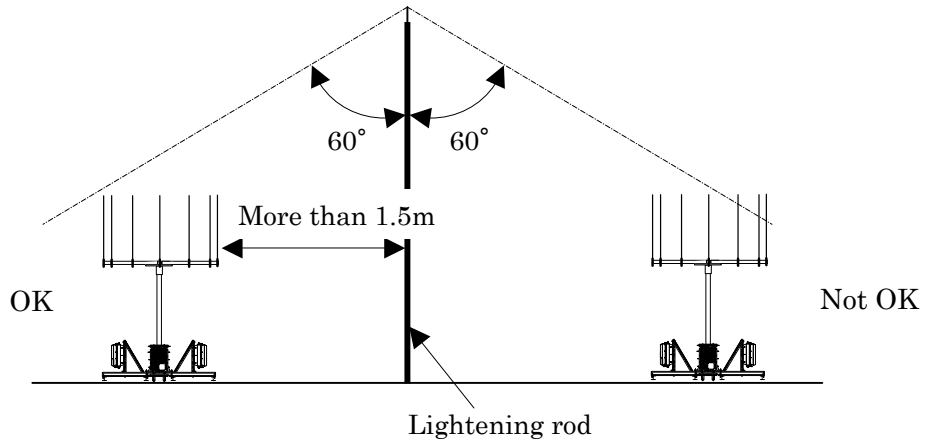

Lightening protections for antenna - Lightning rod -

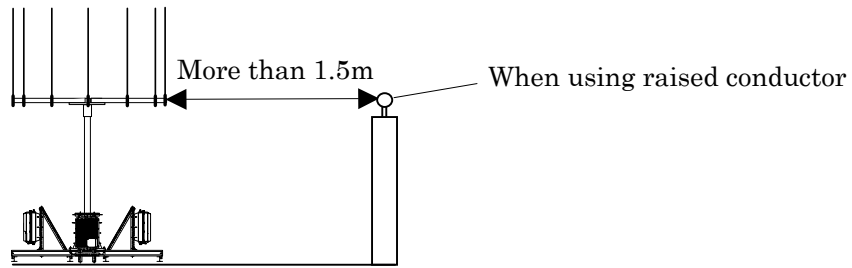

Lightening protection for antenna - Raised conductor -

1.5.2.5 Isolation from drain

When installing the antenna on the roof of a building, keep the isolation distance of more than 1 m to prevent the pedestal from blocking the drain of the roof.

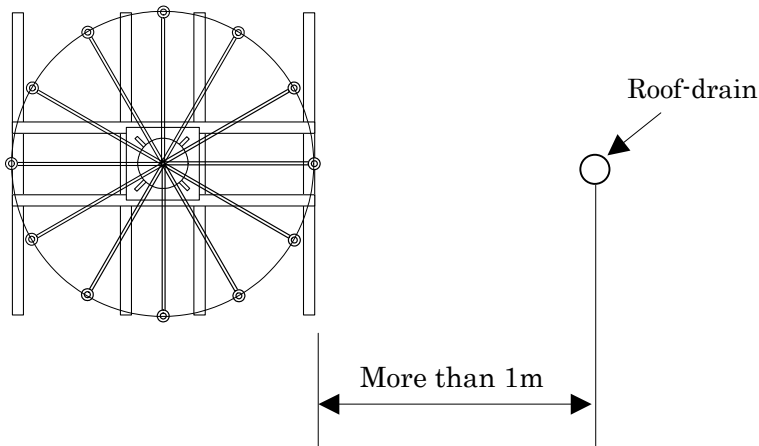

Isolation distance from roof drain

1.5.2.6 Isolation from obstacle

When installing the antenna on the building, be sure that there is no object such as roof buildings or advertising display that may block the electric wave around the antenna.

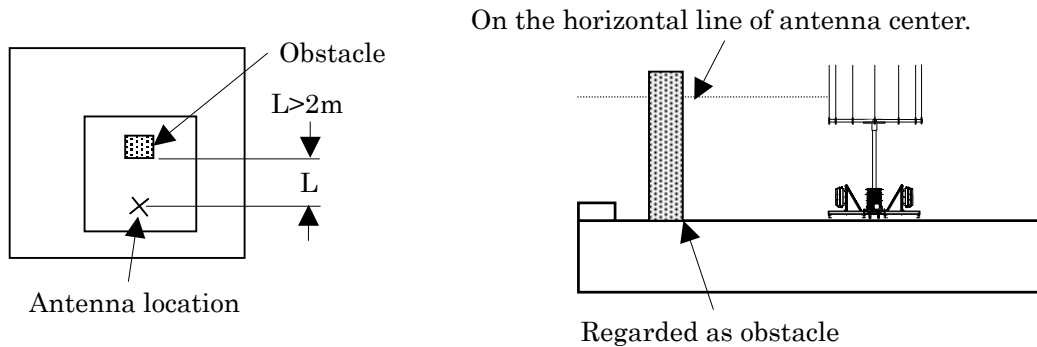

Isolation from obstacle

1.5.2.7 Horizontal sight angle

Horizontal sight angle shall be 330 degrees or more for the purpose of enlarging the area. In addition, there shall be no obstruction along the direction to be covered.

Definition of horizontal sight angle: Horizontal sight angle from the antenna shall be more than the standard value.

(Angle added by the sight direction in the horizontal angle of 360 degrees around the antenna excluding the direction that cannot keep the sight due to obstruction on the roof: See below)

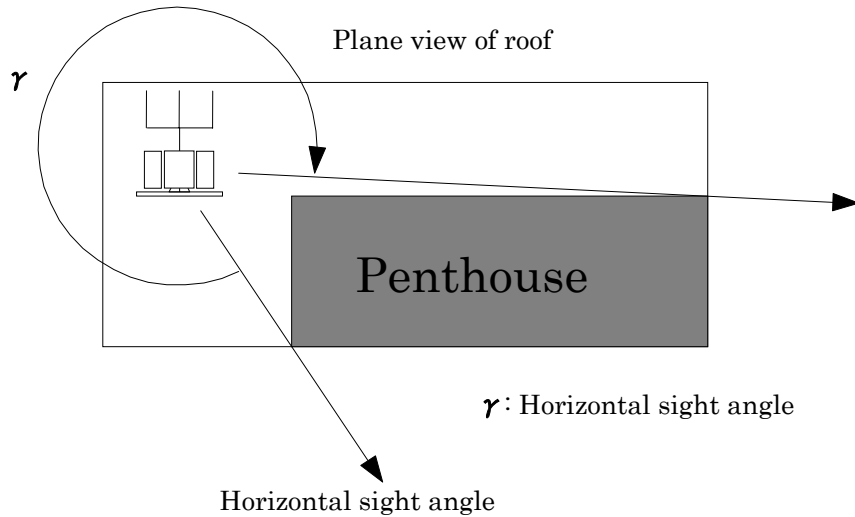

1.5.2.8 Vertical sight angle

The standard value shown in the following table shall be secured for vertical sight angle.

Vertical sight angle standard values

Tilt angle	Standard value
7dBi (20 degrees)	30 degrees
9dBi (10 degrees)	20 degrees
11dBi (5 degrees)	10 degrees
11dBi (0 degree)	5 degrees

Upon confirmation of the “distance from edge” of an object, be sure “distance from edge” is within the corresponding “allowable distance” in the following table.

Vertical sight angle vs. allowable distance

	Applied height (m)	Calculated value (m)	11dBi 0 degree	11dBi 5 degrees	9dBi 10 degrees	7dBi 20 degrees
Allowable sight angle (degrees)			5	10	20	30
Allowable distance (m)	4 or more	4	45.7	22.7	11.0	6.9
	Over 3.5 and below 4	3.5	40.0	19.8	9.6	6.1
	Over 3 and below 3.5	3	34.3	17.0	8.2	5.2
	Over 2.5 and below 3	2.5	28.6	14.2	6.9	4.3
	Over 2 and below 2.5	2	22.9	11.3	5.5	3.5
	Over 1.5 and below 2	1.5	17.1	8.5	4.1	2.6
	Over 1 and below 1.5	1	11.4	5.7	2.7	1.7
	Over 0.5 and below 1	0.5	5.7	2.8	1.4	0.9

$\tan 5^\circ = 0.0874886$, $\tan 10^\circ = 0.1763269$, $\tan 20^\circ = 0.3639702$, $\tan 30^\circ = 0.5773502$

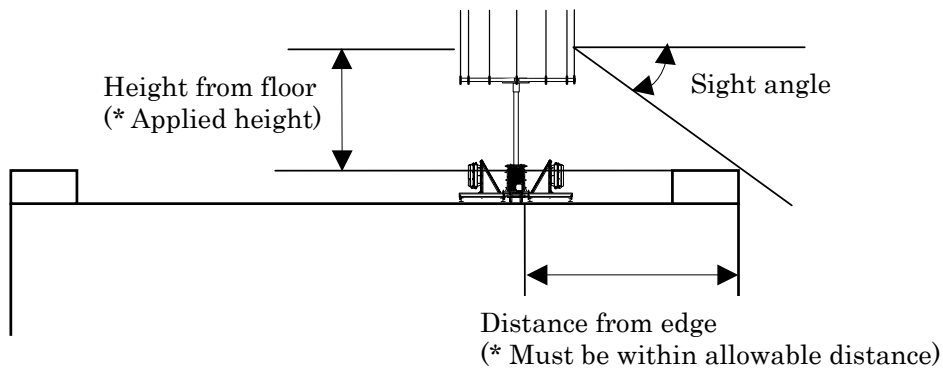

Sight angle and allowable distance

1.5.2.9 Isolation from radio system

When installing a base station, it is necessary to keep enough space so as not to give damage to other existing base stations.

1.5.2.9.1 Isolation from iBurst system

When installing the iBurst systems on the same plane of the roof, keep the specified isolation distance.

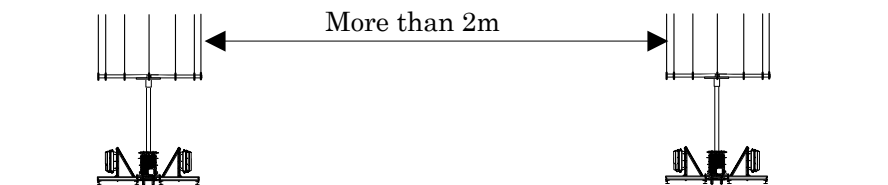

Interval between iBurst systems

1.5.2.9.2 Isolation from GSM/CDMA base station

When installing the antennas in GSM/CDMA base station close together, sufficient survey must be conducted

- Do not installing the iBurst antenna to direction of radiation.
- When installing the iBurst antenna to anti-direction of radiation, please make sure shown below parameter and new calculation of isolation distance will be required.

Radiation pattern of iBurst antenna

Used frequency Rang (Up-link/Down-link) of GSM/CDMA antenna

Output power rating of GSM/CDMA antenna

Characteristic of BPF of GSM/CDMA antenna

Radiation pattern of GSM/CDMA antenna

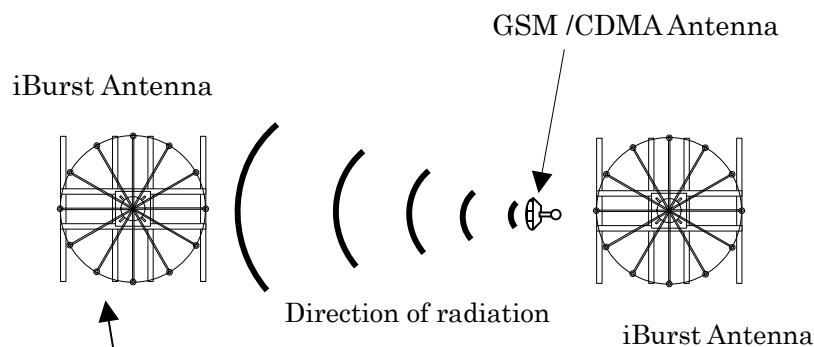

Example of isolation distance from GSM/CDMA base station --Top View

(Note)

When a base station is installed close to other base station, a failure may possibly be caused on or from the associated base station.

1.5.2.9.3 Isolation from other radio system

Regarding the existing antenna of other radio system such as TV antenna, effect on the associated antenna shall be fully taken into account at the time of installation.

As TV antenna has directivity, no base station shall be located in the direction of the antenna. There may be the possibility of having an effect even outside the range of directivity due to the effect of reflection depending on the environment around the location. Practically, as shown in the following figure, the base station must not be located within the range of existing antenna direction $\pm 45^\circ$ on the same roof.

More than 3 m distance (horizontal) shall be allowed from TV antenna and installation within the range of ± 45 degrees from TV antenna direction shall be avoided.

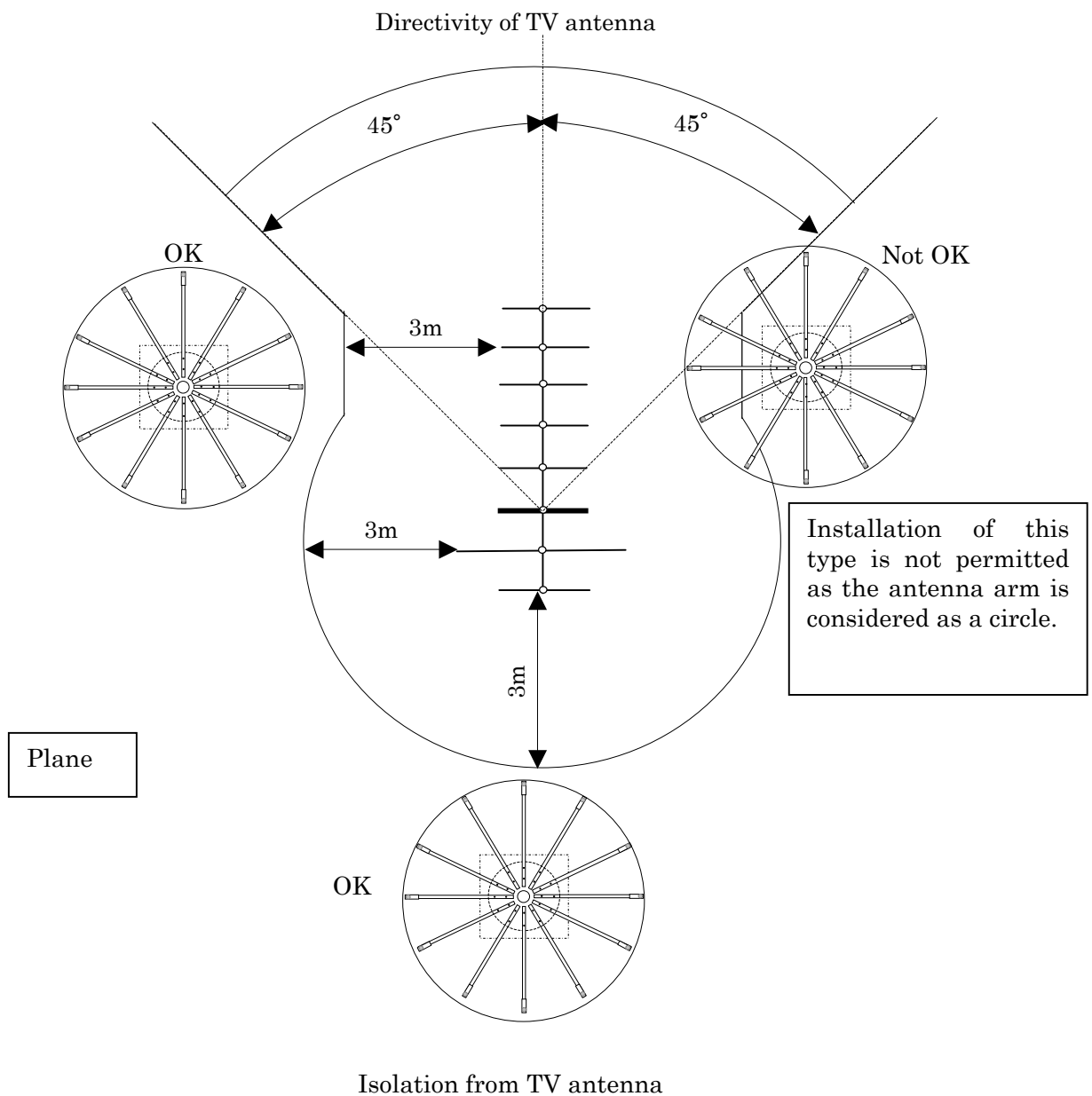

1.5.2.10 Isolation from outdoor unit of air conditioner, etc.

When installing an antenna, it is necessary to keep the antenna away from the rotating metal such as a heat-dissipating fan of the outdoor unit of air conditioner, ventilating fan, etc.

When there is any rotating metal on the same horizontal plane, it is necessary to keep the isolation of more than 1.5 m. If, however, this isolation cannot be secured, isolation of more than 0.5 m from the top and bottom edges of the antenna must be secured.

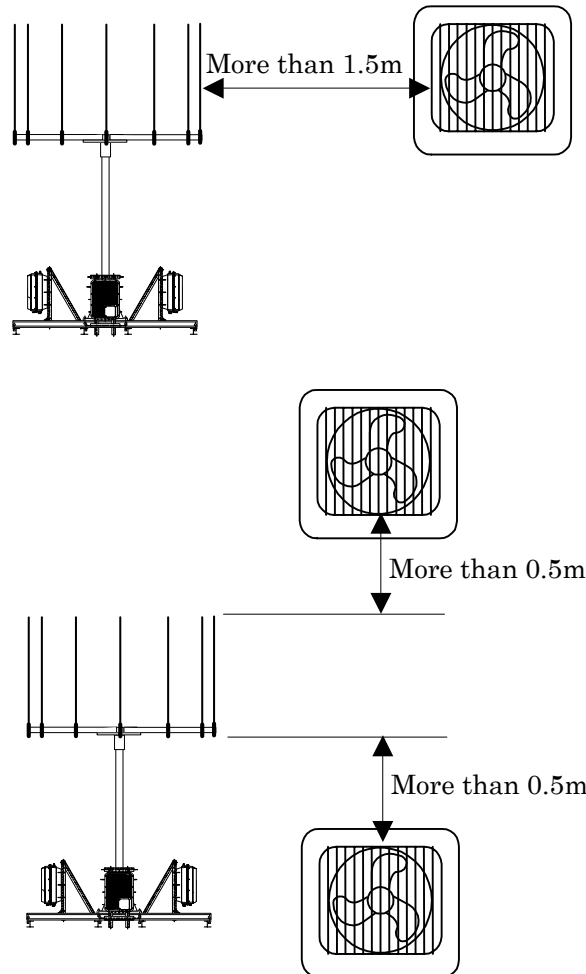

Isolation from outdoor unit

1.5.2.11 Isolation from power line

Isolation from power line shall be executed by confirming the details in accordance with the related laws. As power producer includes electric power company and Train Company, pay full attention to the surrounding conditions.

1.5.3 Criteria for selecting PA unit location

1.5.3.1 Mounting direction of PA unit

PA unit can be installed only vertically with the antenna connector up.

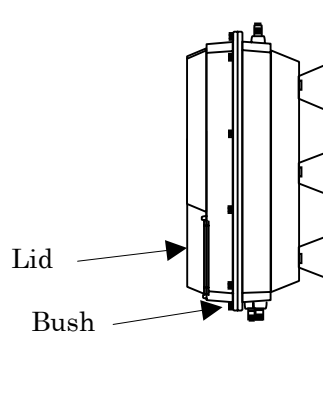

1.5.3.2 Securing space for PA unit

1.5.3.2.1 Workspace

When installing on the roof or the like, keep approx. 1m as a maintenance space around the PA unit.

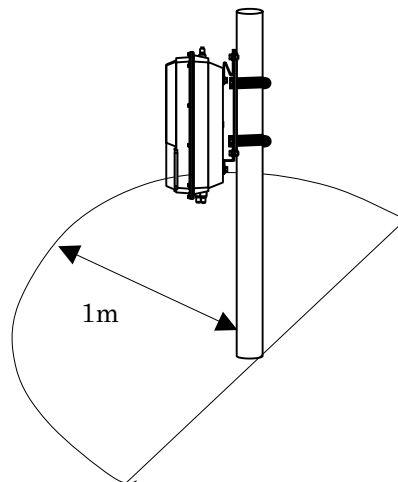

Workspace for PA unit

1.5.3.2.2 Ventilation space

When installing the PA unit on the wall, allow a ventilation space of more than 15mm.

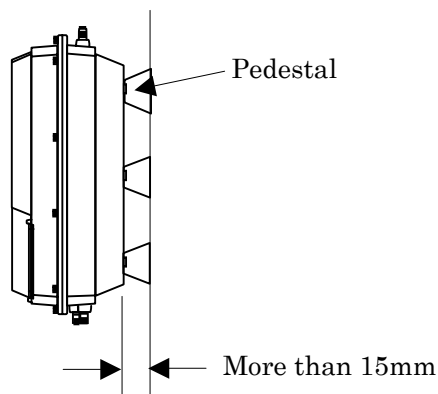

Example of ventilation space for PA unit

1.5.3.3 Lightning protection

PA unit installation shall be designed to be within the protection angle (* 60 degrees) of the lightning rod.

* Lightning protection method is obeying the law by State regulations.

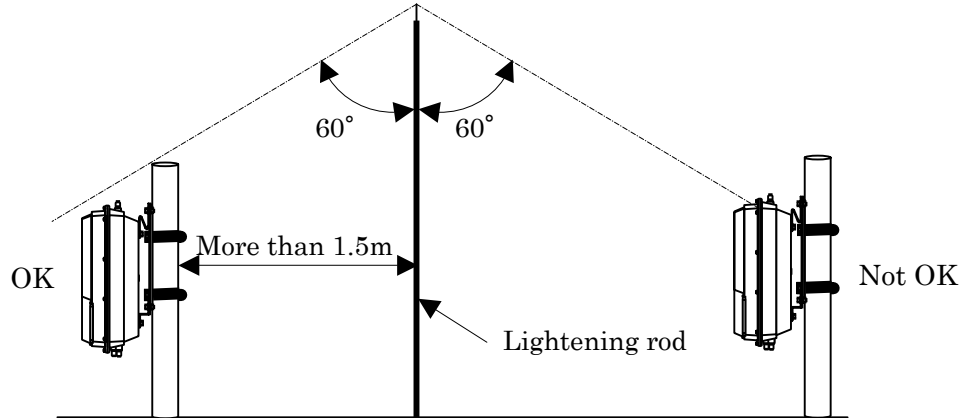

Lightning protection for PA unit - Lightning rod-

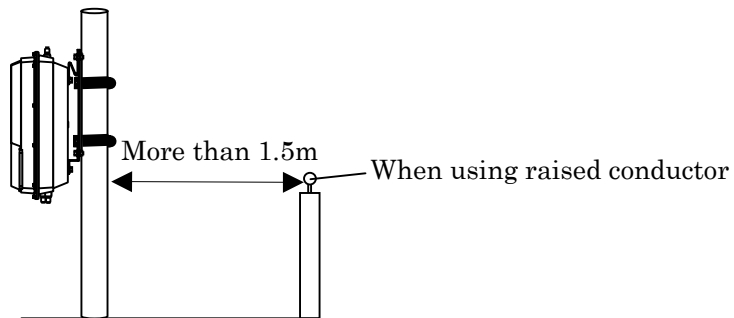

Lightning protections for PA unit- Raised conductor -

1.5.3.4 Isolation from drain

When installing the PA unit on the roof of a building, keep the isolation distance of more than 1 m to prevent the pedestal from blocking the drain of the roof.

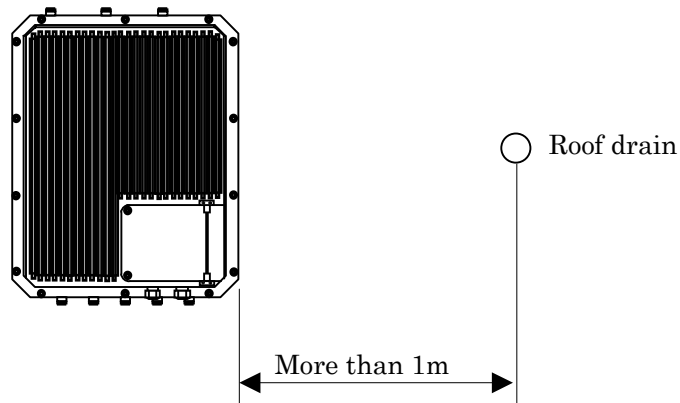

Isolation from drain

1.5.4 Criteria for selecting GPS unit location

1.5.4.1 Accuracy of GPS mounting

Inclination of GPS against the vertical direction shall be 4.5 degrees max.

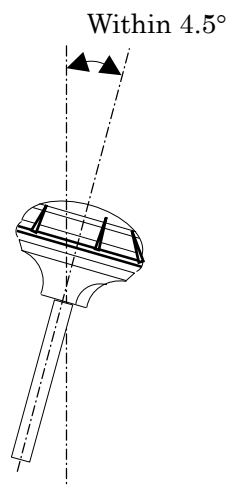

Accuracy of GPS unit mounting

1.5.4.2 GPS sight space

There shall be no obstruction at the place of 25 degrees or more from the horizontal surface at the center (excluding antenna).

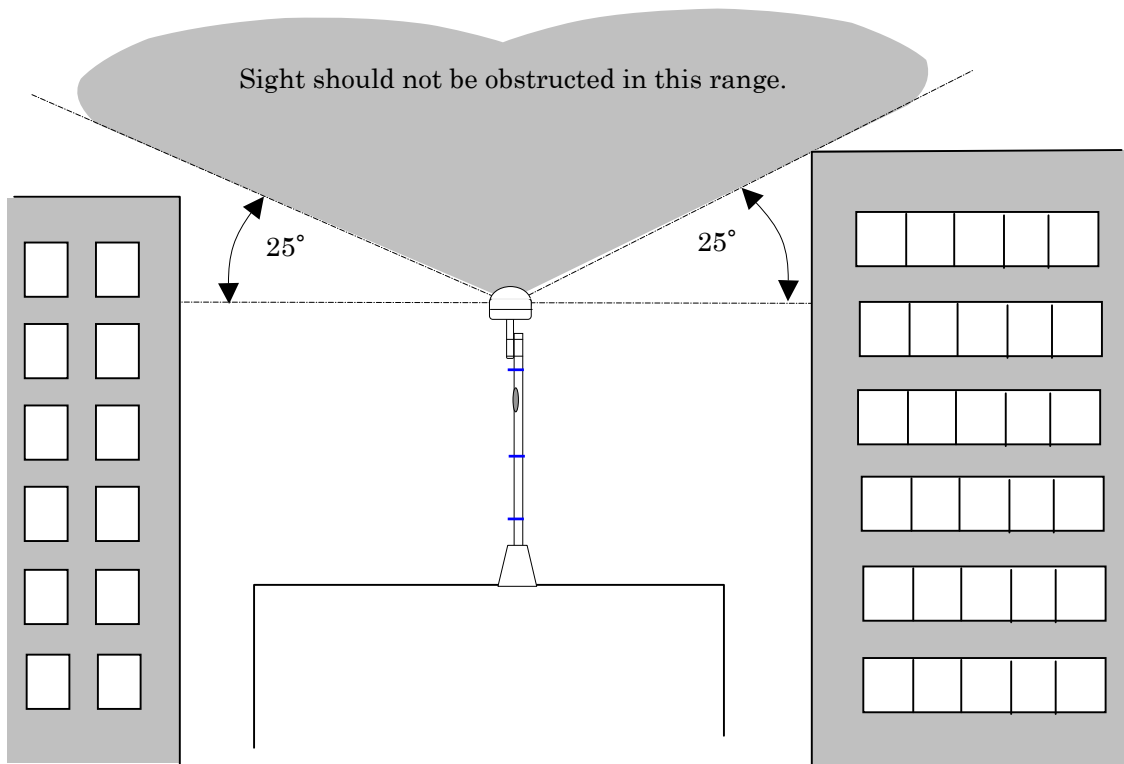
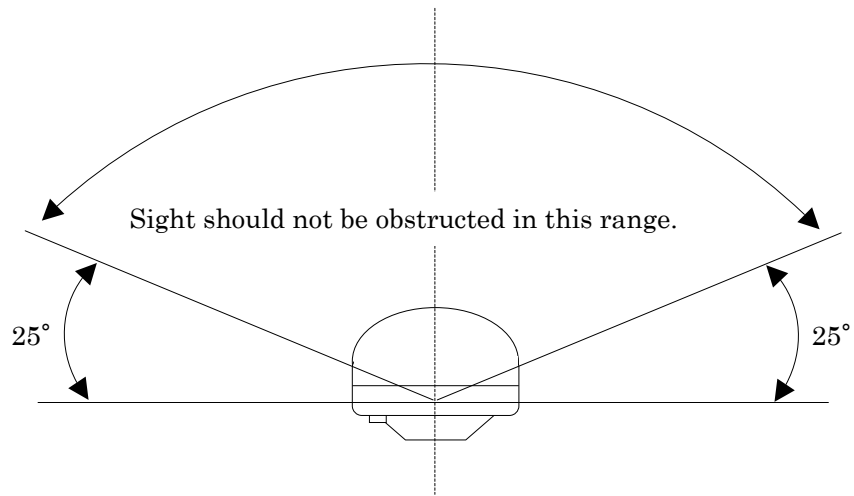

GPS sight space

1.5.4.3 Lightning protection for GPS

GPS unit installation shall be designed to be within the protection angle (* 60 degrees) of the lightning rod.

The GPS unit shall be isolated by more than 1.5 m from the lightning rod, lightning conductor, or raised conductor.

When the GPS mounting pole is made of metal, isolation of more than 1.5 m is recommended like the above.

* Lightning protection method is obeying the law by State regulations.

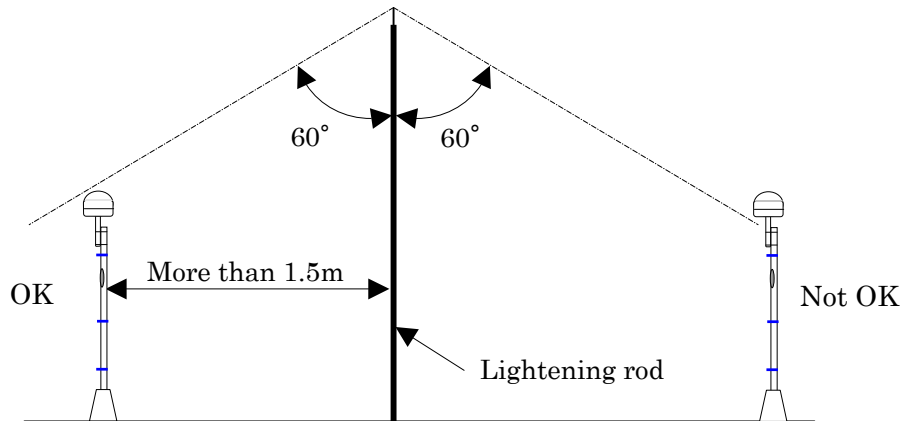

Lightening protections for GPS - Lightning rod -

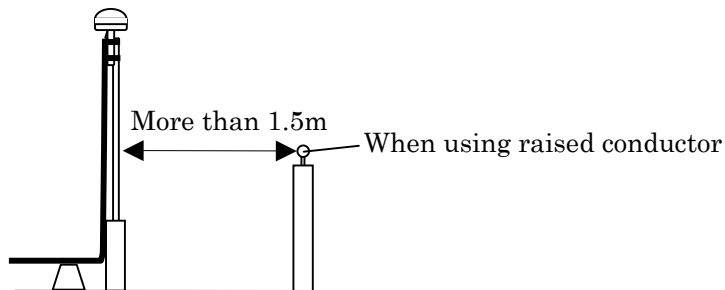

Lightening protections for GPS - Raised conductor -

1.5.5 Criteria for selecting Base unit location

1.5.5.1 Installation space for Base unit

A space for installing and maintaining the Base unit shall be secured at the place confirmed in the site survey.

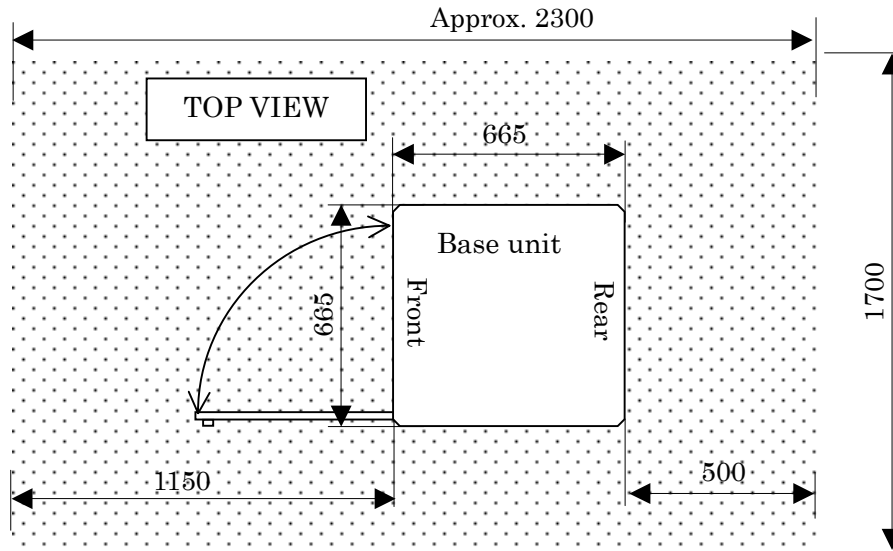

Installation space for Base unit

1.5.5.2 Lightening protection for Base unit

When installing the Base unit outdoors, be sure to design the Base unit to be located within the protection angle (* 60 degrees) of the lightening rod.

* Lightening protection method is obeying the law by State regulations.

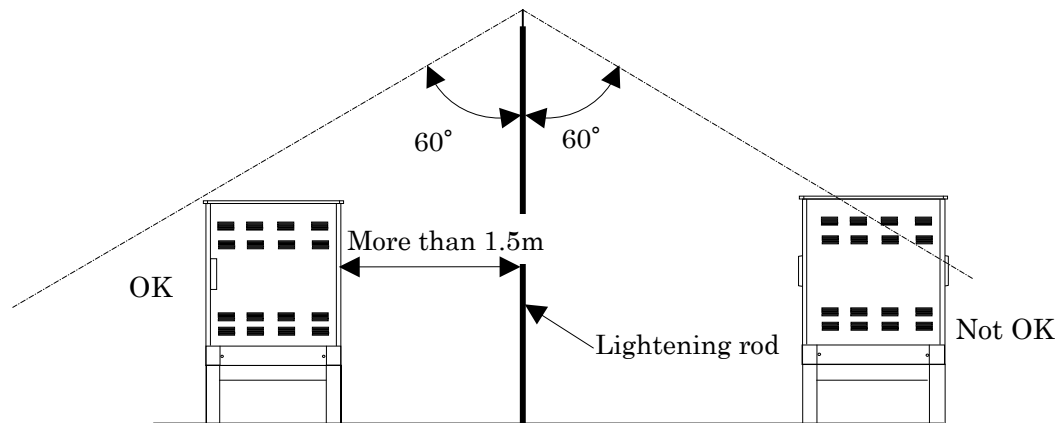

Lightening protection for Base unit - Lightening rod-

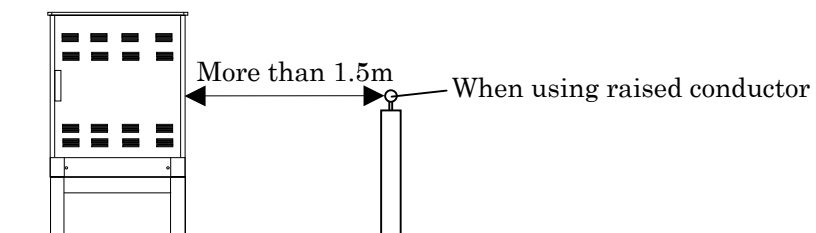

Lightening protection for Base unit - Raised conductor -

1.5.5.3 Isolation from drain

When installing the Base unit outdoor such as on the building roof, keep the isolation distance of more than 1 m so that the pedestal may not block the neighboring drain or may not obstruct the flow of wastewater.

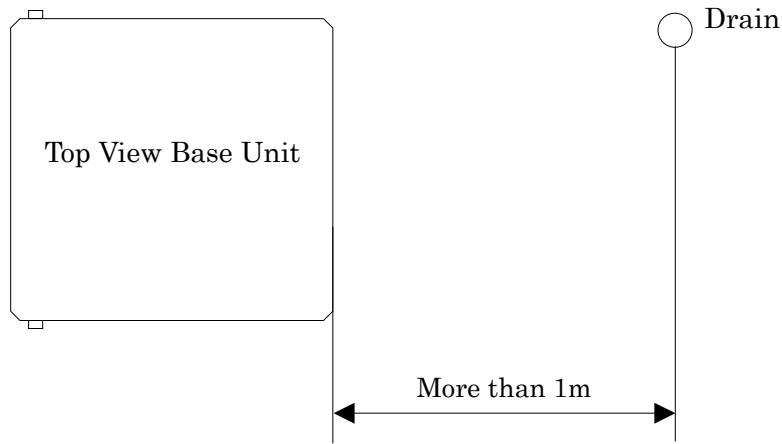

Isolation from drain

1.5.5.4 Isolation from iBurst antenna

When installing both Base unit and antenna on the same plane such as on the roof, allow an isolation distance of 2m between the antenna and Base unit.

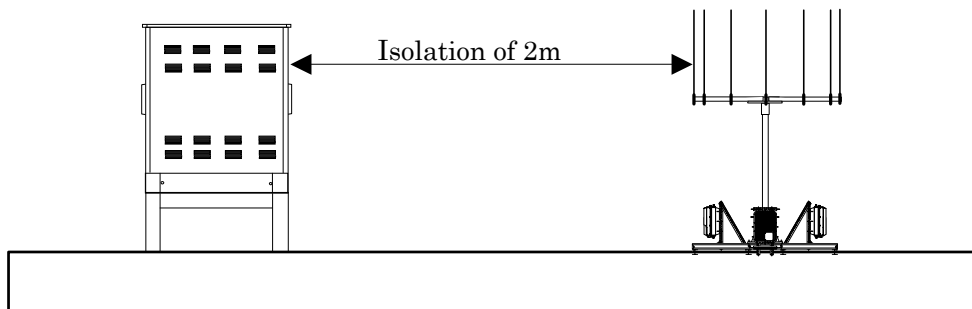

Isolation from antenna

1.5.6 Precautions on cabling

1.5.6.1 Ground

- 1) The grounding terminal of the power cable must be surely connected to the ground.

(Note)

Unless ground connection is completed, noise may be caused during communication or equipment may be damaged as lightning protection by ground line is disabled.

- 2) Ground shall be 100 Ω or less.

(Note)

If the ground resistance is more than 100 Ω , sound or image failure may be caused in other radio equipment.

1.5.6.2 Cable

- 1) Be sure to lay the network cable and power cable in separate ducts.

(Note)

If the network cable and power cable are laid in a bundle, noise may be caused during communication or sound or image failure may be caused in other radio equipment.

- 2) Attach an identification label on the power box, circuit breaker, and Ethernet switch to indicate the cable belongs to the base station.

(Note)

Unless identification label is attached on the power box and circuit breaker, PA unit, Base unit power may be turned off erroneously. Or power to other electrical devices may be turned off erroneously resulting in a good deal of trouble.

Unless identification is attached on the network cable, identification work for network cable may be difficult.

- 3) Allow an isolation distance of more than 10 cm between the network cable and power cable.

(Note)

If the line cable and power cable are laid close together, noise may be caused during communication.

- 4) Do not lay power cable within 3 m from the TV antenna.

(Note)

If power cable is close to the TV antenna, TV sound and image may be damaged.

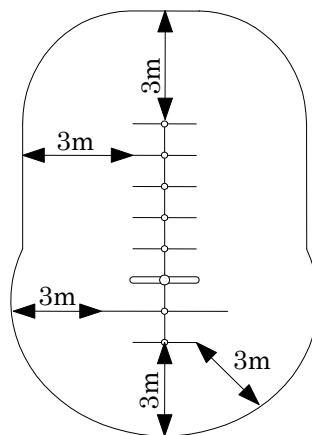

Power cable and TV antenna

1.5.7 Precautions in installation on the roof

- 1) When laying the network cable and power cable on the roof, pass them through the duct for cable protection to the specified places while putting them on the pedestals for raised cabling.

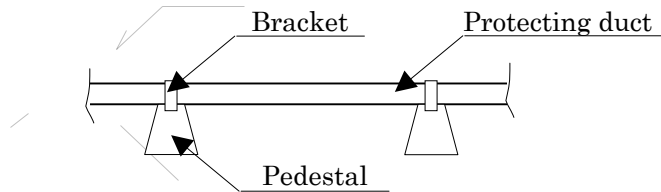

Cabling on the roof - 1 -

- 2) When laying the network cable and power cable along the wall, fix them through the duct in the same manner as the above.

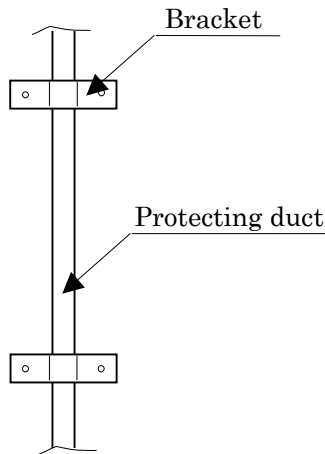

Cabling on the roof - 2 -

1.5.8 Separation of power systems

- 1) For the convenience of maintenance, the Base unit and PA unit shall be separately provided with power cabling. In addition, four PA units shall be provided with independent power systems each having a specified circuit breaker.

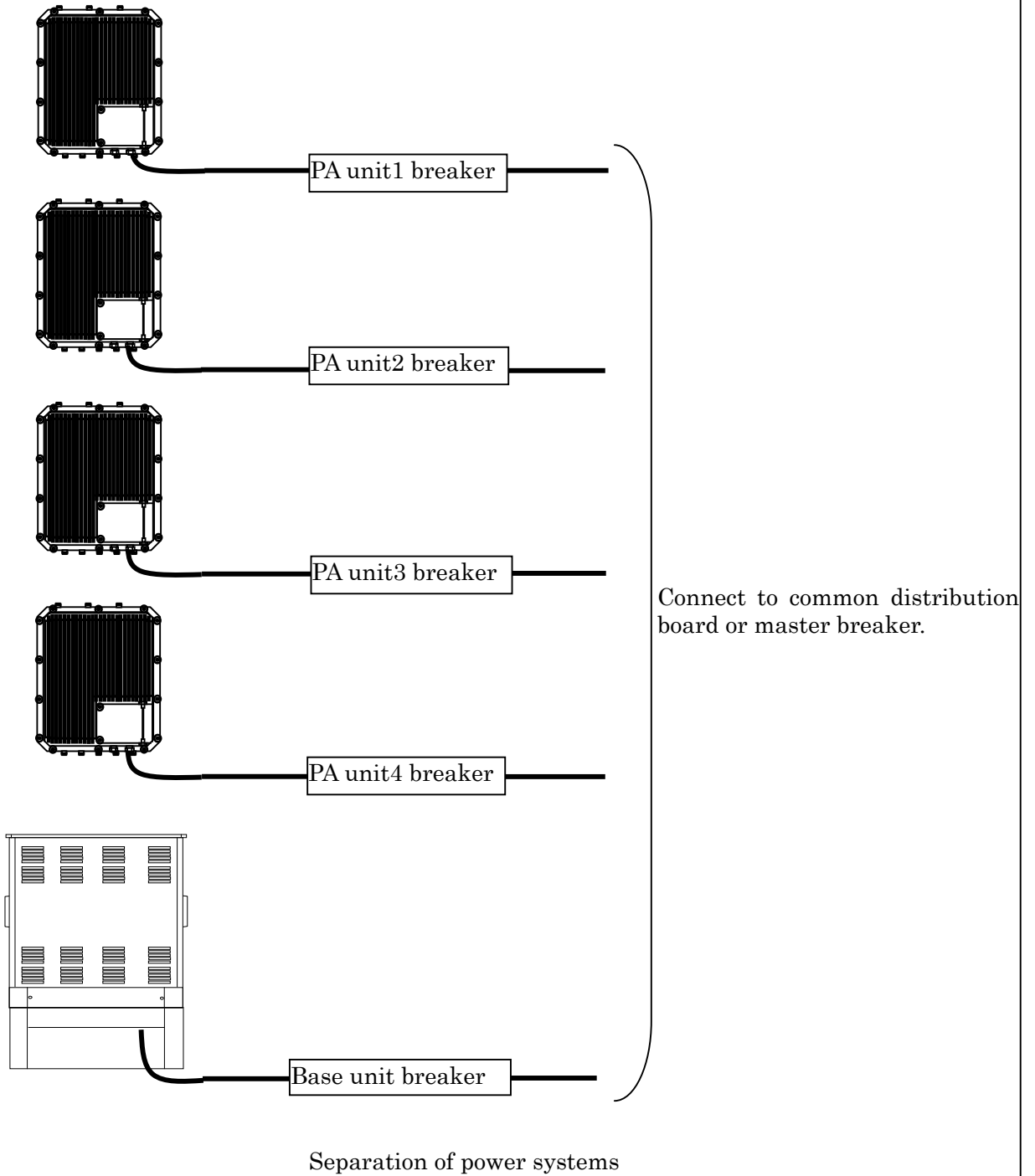

1.5.9 Waterproof treatment for connector and bushing

For connectors and bushing, it is necessary to use appropriate self-shrinkable tube or wind self-fusing tape and then vinyl tape around them for water preventing measure to protect the equipment against damage by water immersion.

In waterproof treatment, it is important to cover the root of the connectors and bushings. See the following figure.

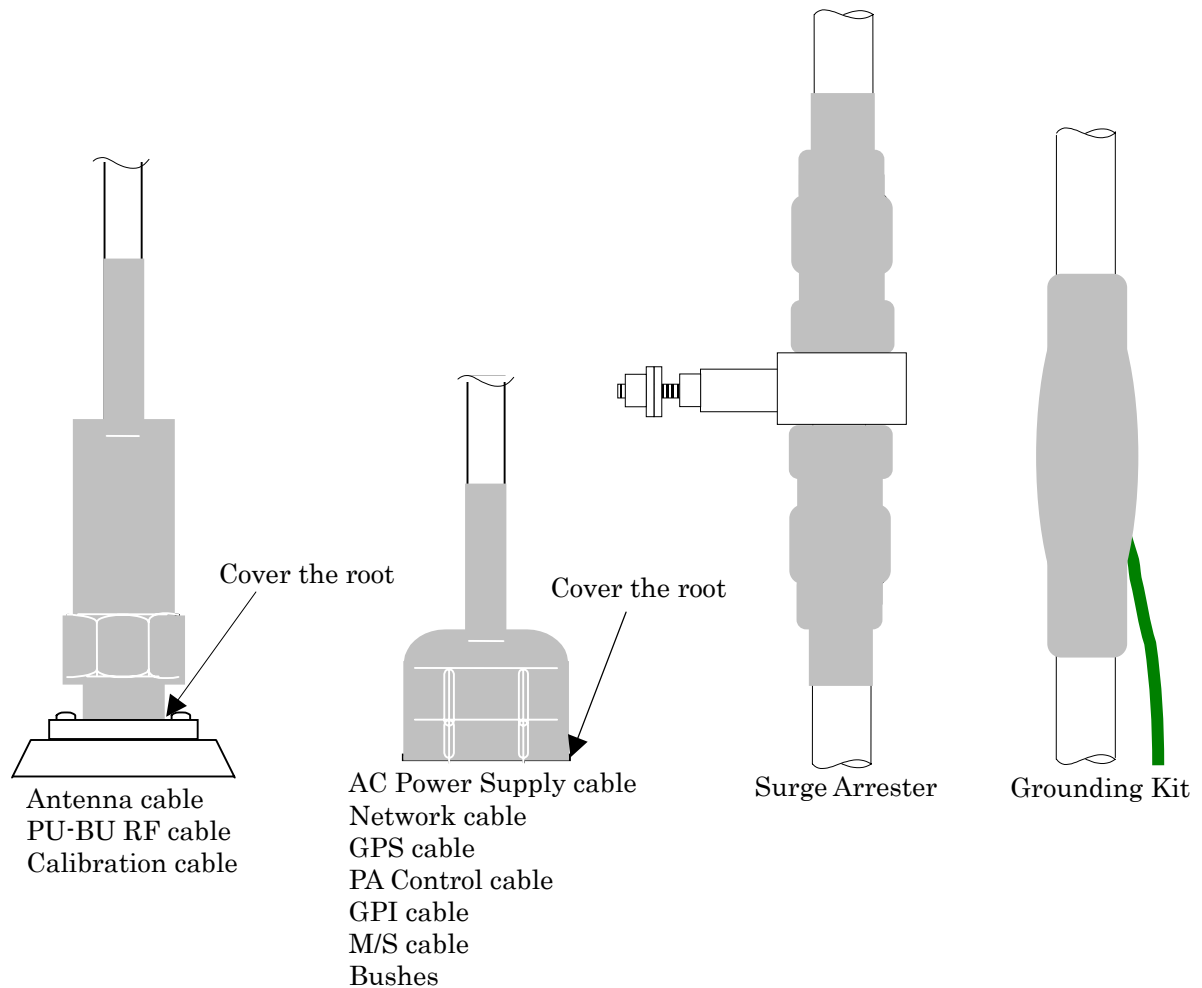

Waterproof treatment for connector and bushing

2 Configuration of Base Station and Accessories









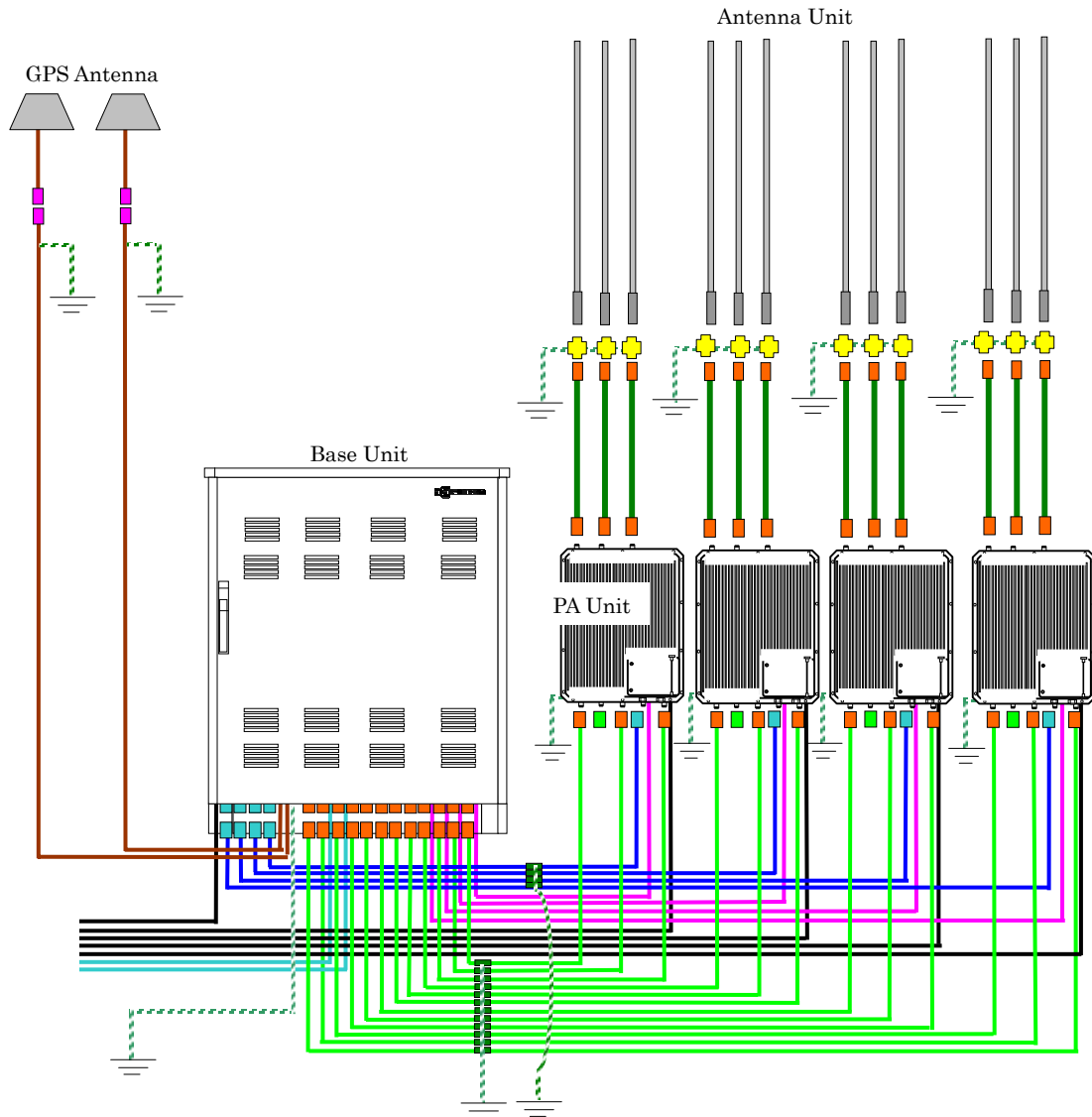





2.1 Configuration of Base Station

2.1.1 System Diagram

Two connecting types are provided depending on the method of the calibration cable. One is star connection to connect one Base unit and one PA unit together and the other is daisy chain connection to connect one Base unit and two PA units in series.









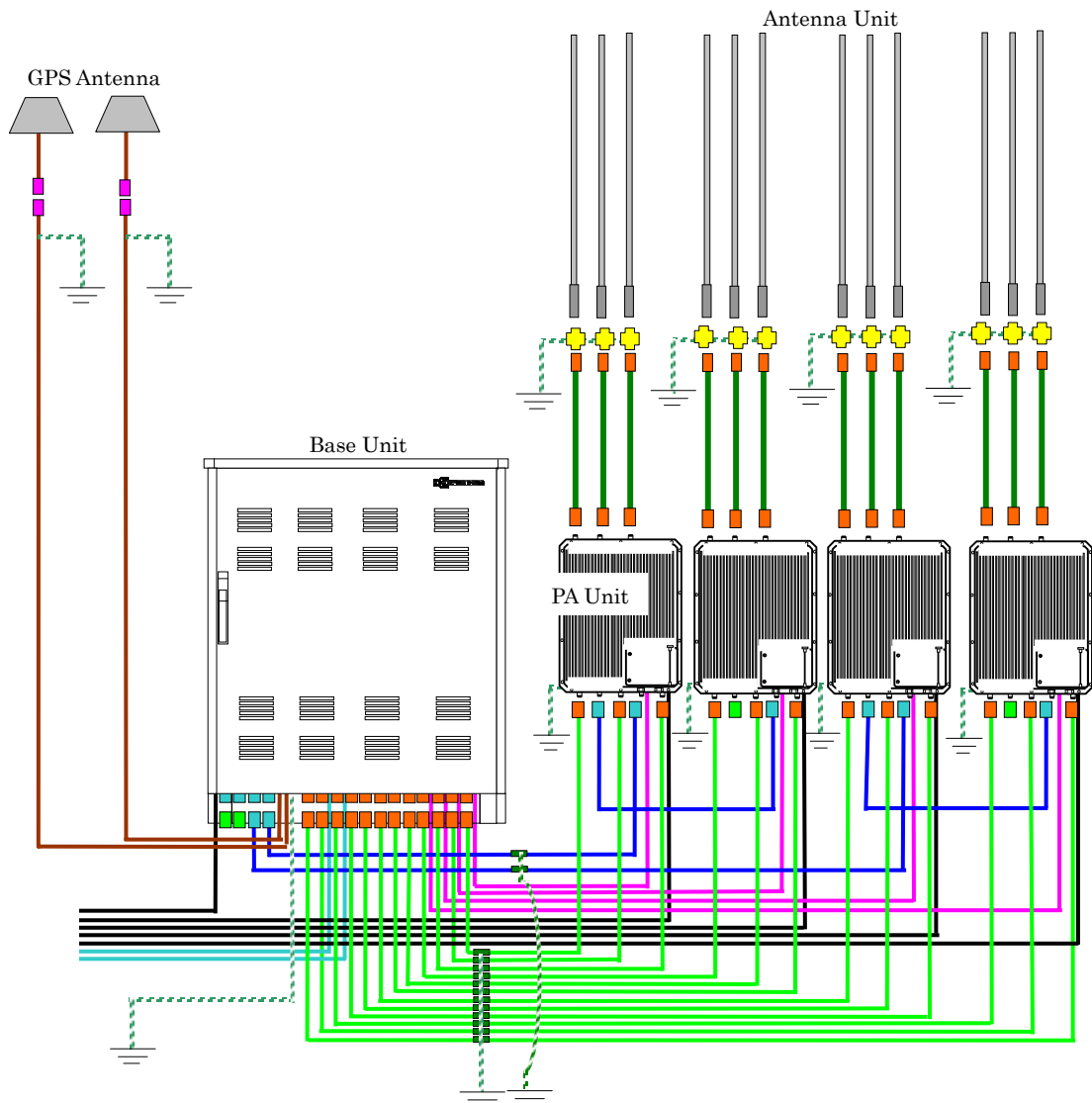





2.1.1.1 Star connection



- | | |
|------------------------------------------------------------------------------------------------------------------------------|-------------------------------------------------------------------------------------------------------------|
|  Antenna Cable |  N (P) Type Connector |
|  PU-BU RF Cable |  TNC (P) Type Connector |
|  PA Control Cable (Shielded Twisted Pair) |  TNC (P) Type Terminator |
|  Calibration Cable |  N (J-J) Type Arrester |
|  GPS Cable (Shielded Twisted Pair AWG24) |  MMP Connector |
|  Network Cable (Shielded Twist Pair) | |
|  AC Power Cable 3P | |
|  Grounding Cable | |
|  Grounding Kit | |

2.1.1.2 Daisy-chain connection



- | | |
|------------------------------------------------------------------------------------------------------------------------------|-------------------------------------------------------------------------------------------------------------|
|  Antenna Cable |  N (P) Type Connector |
|  PU-BU RF Cable |  TNC (P) Type Connector |
|  PA Control Cable (Shielded Twisted Pair) |  TNC (P) Type Terminator |
|  Calibration Cable |  N (J-J) Type Arrester |
|  GPS Cable (Shielded Twisted Pair AWG24) |  MMP Connector |
|  Network Cable (Shielded Twist Pair) | |
|  AC Power Cable 3P | |
|  Grounding Cable | |
|  Grounding Kit | |

2.1.2 Appearance form

2.1.2.1 PA unit

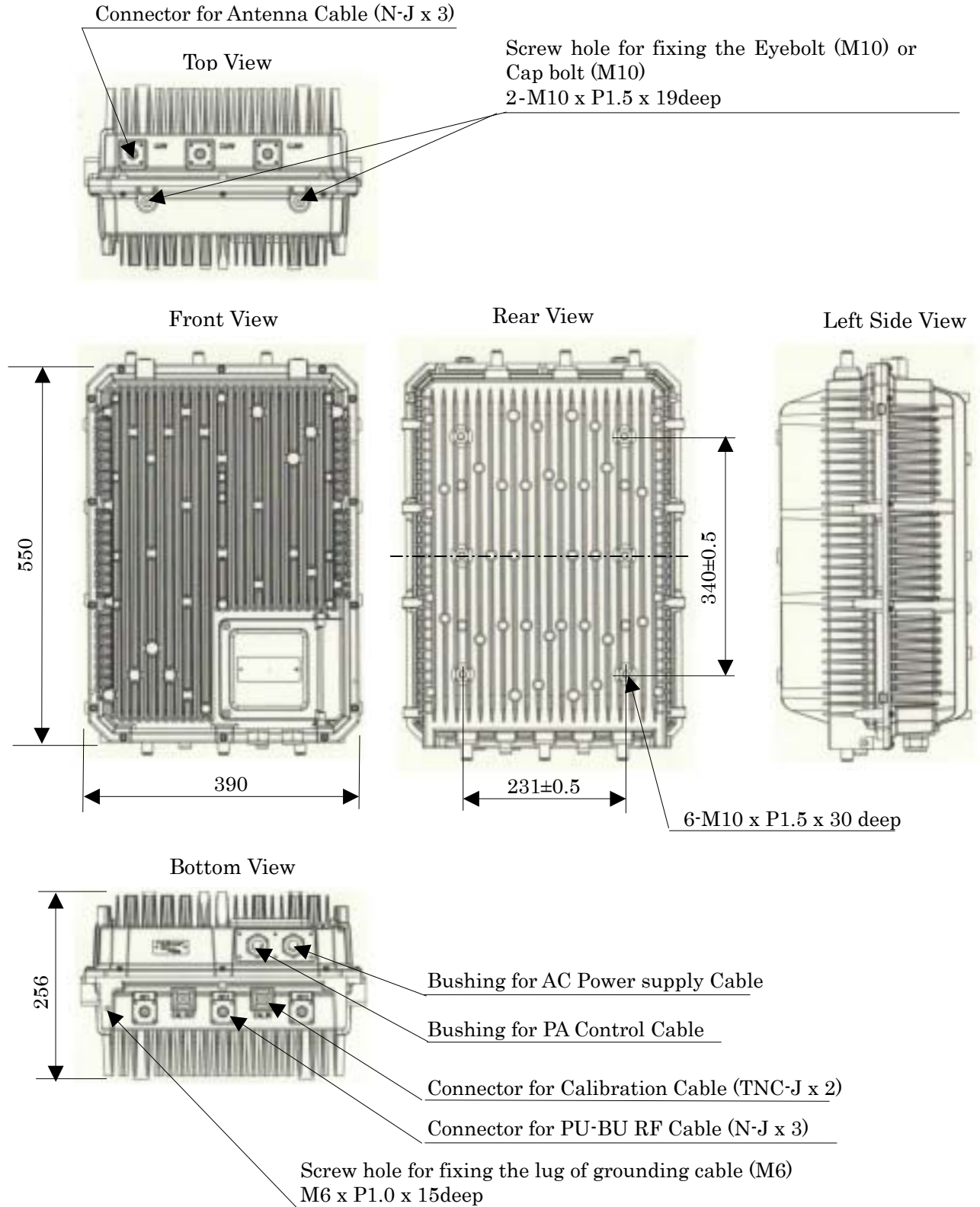

2.1.2.2 Inside LID

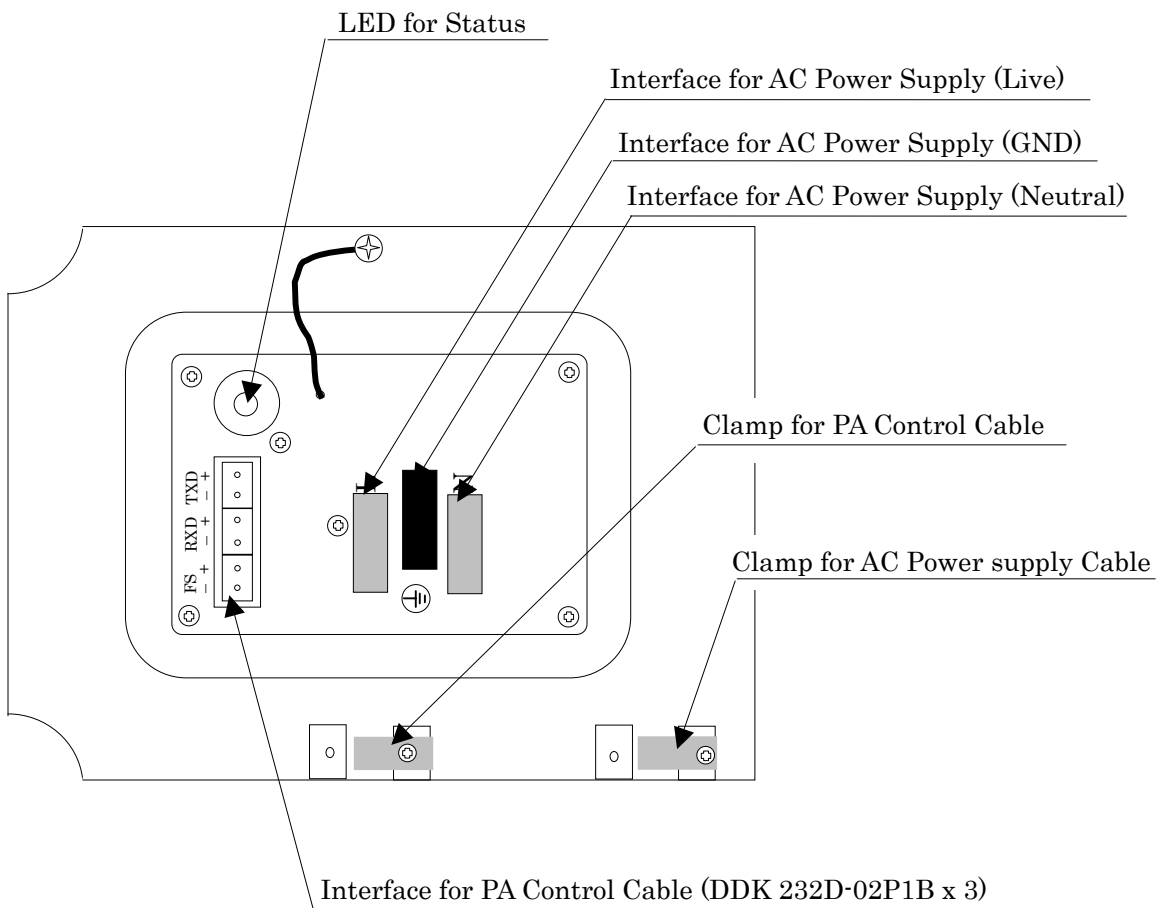
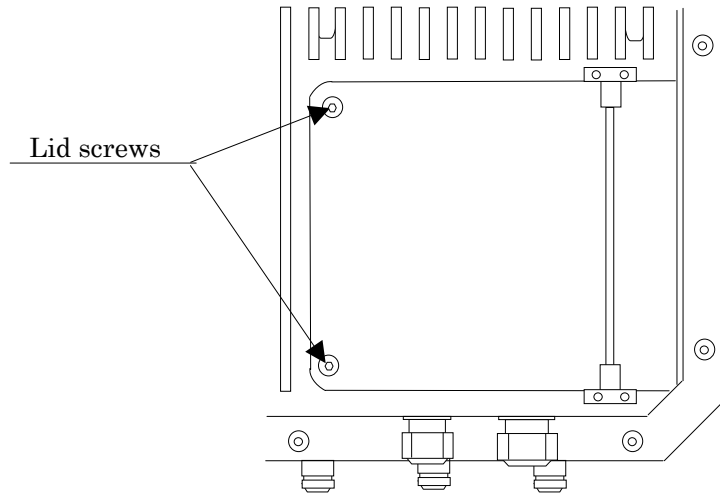

2.1.2.3 GPS unit

Smart Antenna RS422_Cable Mount Type

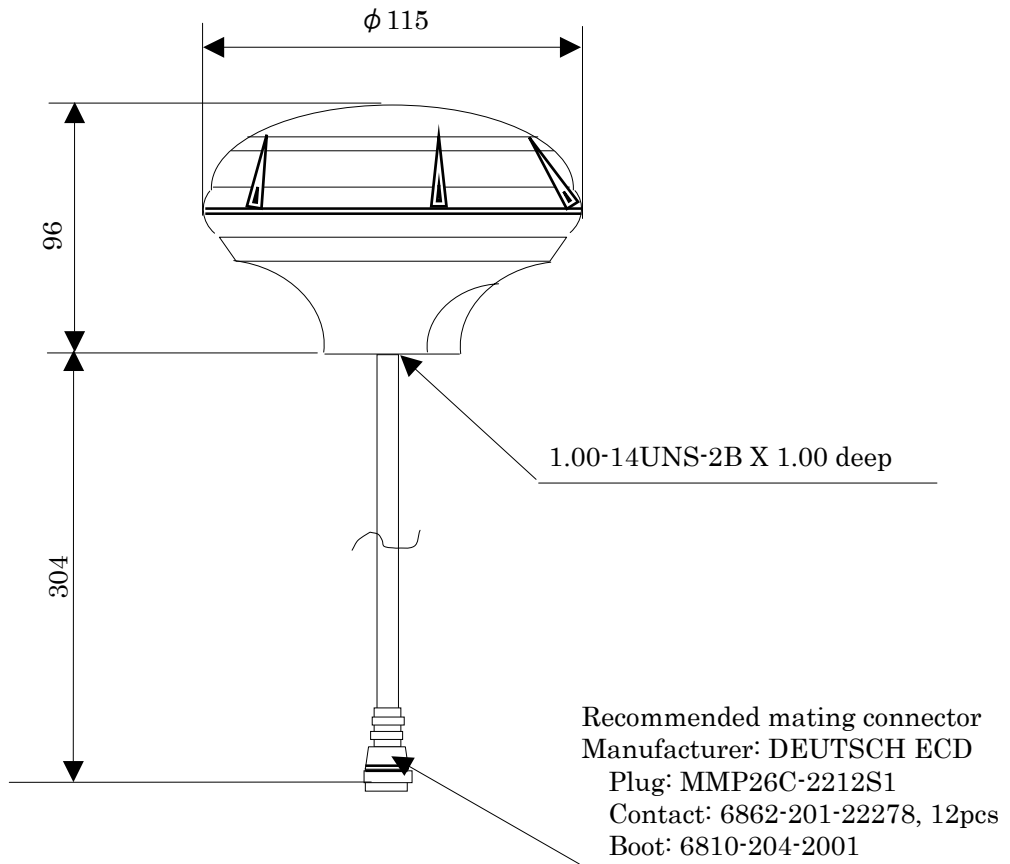

Mount Adaptor

Note) This mounting adaptor is not an accessory of the GPS unit.

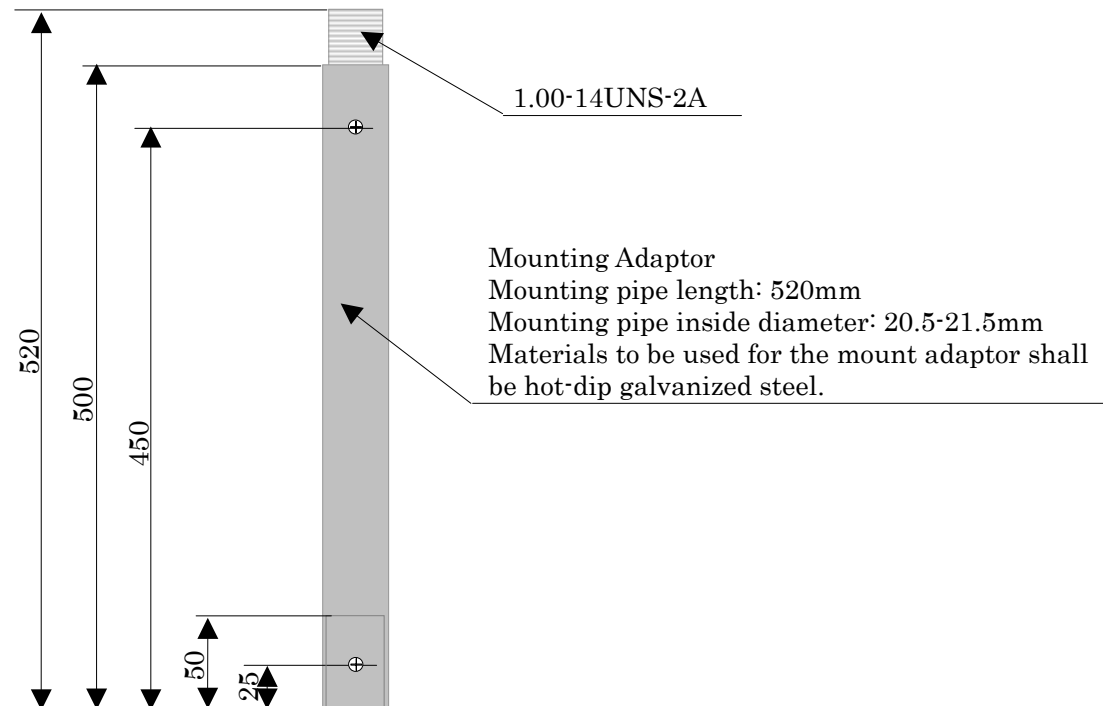

2.1.2.4 Base unit

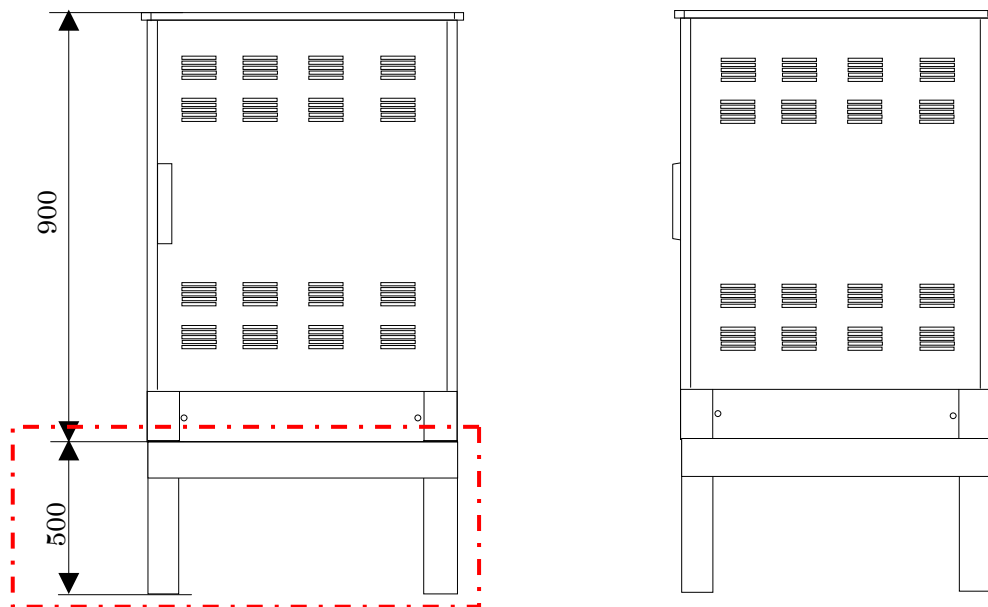
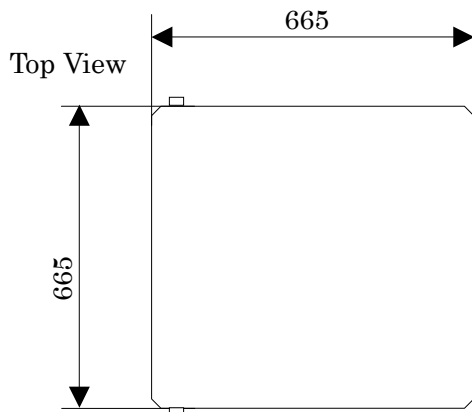

*Installation Base Unit is not included in the Base Unit.

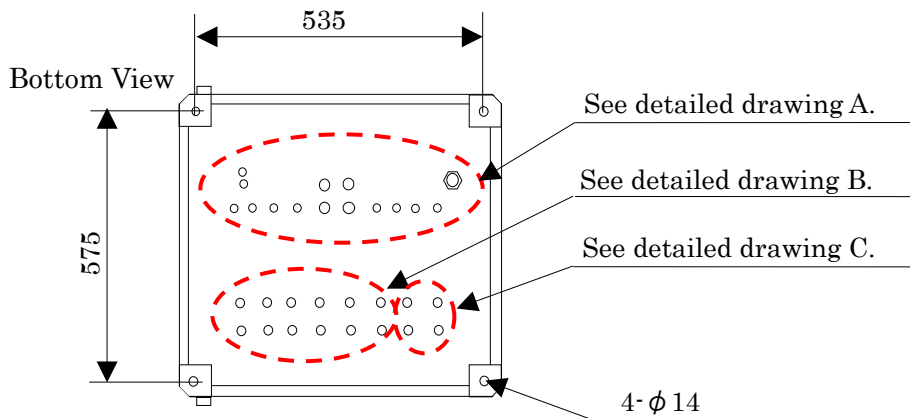

2.1.2.4.1 Bottom details

This figure looked from bottom side

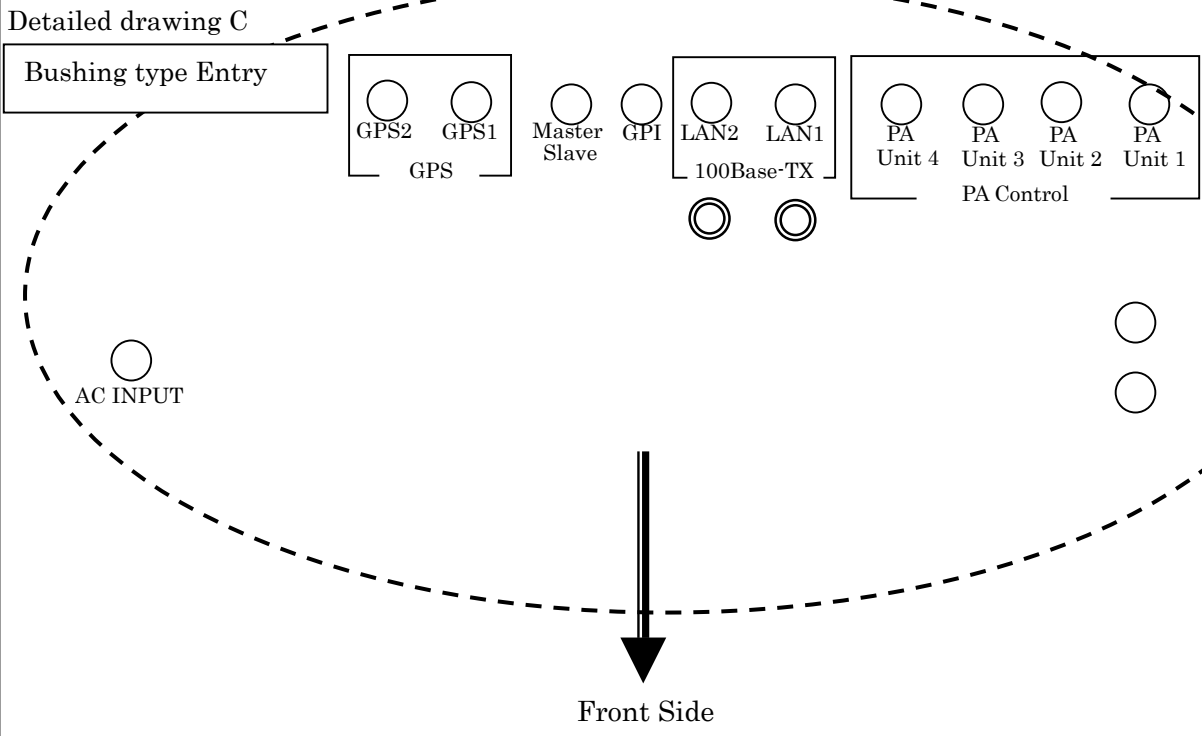
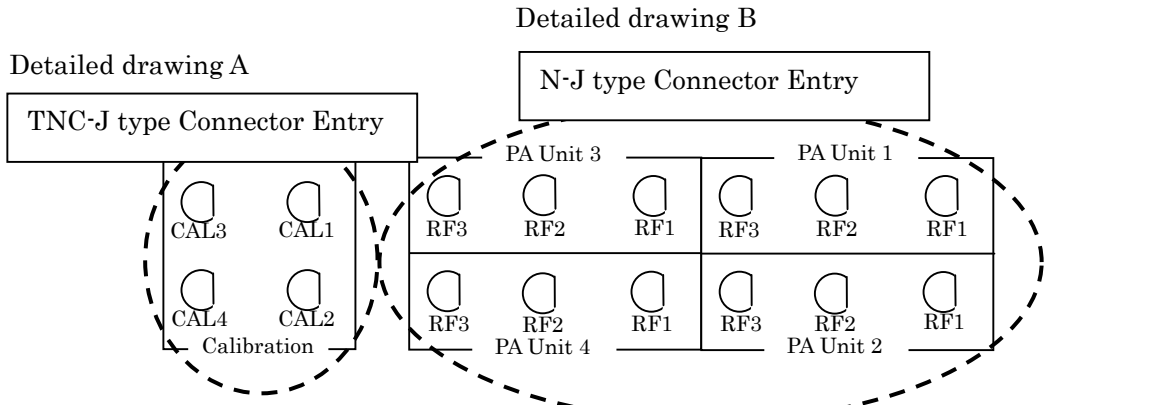

Blind Cap

2.1.2.4.2 Inside Base unit

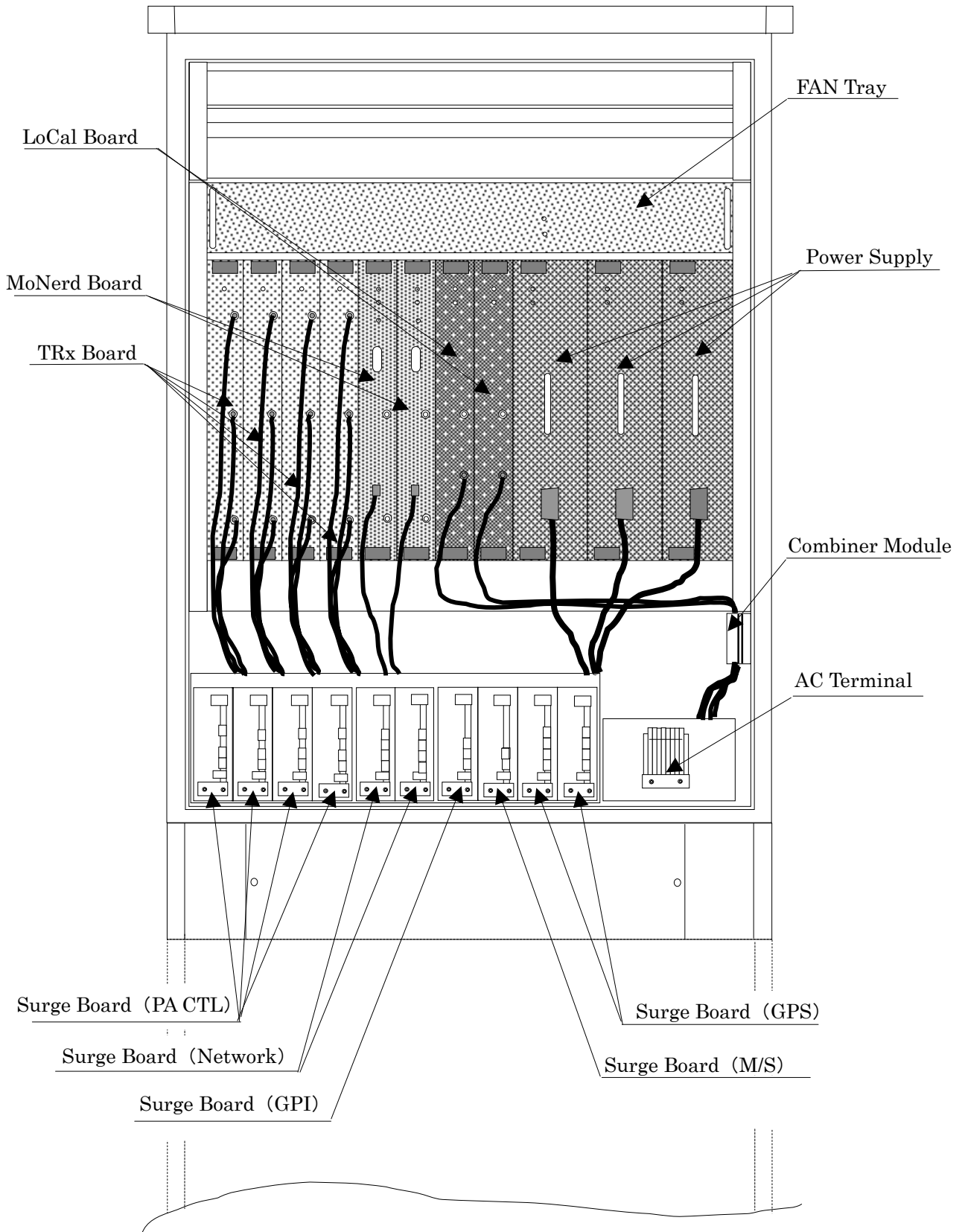

2.1.2.4.3 Surge board

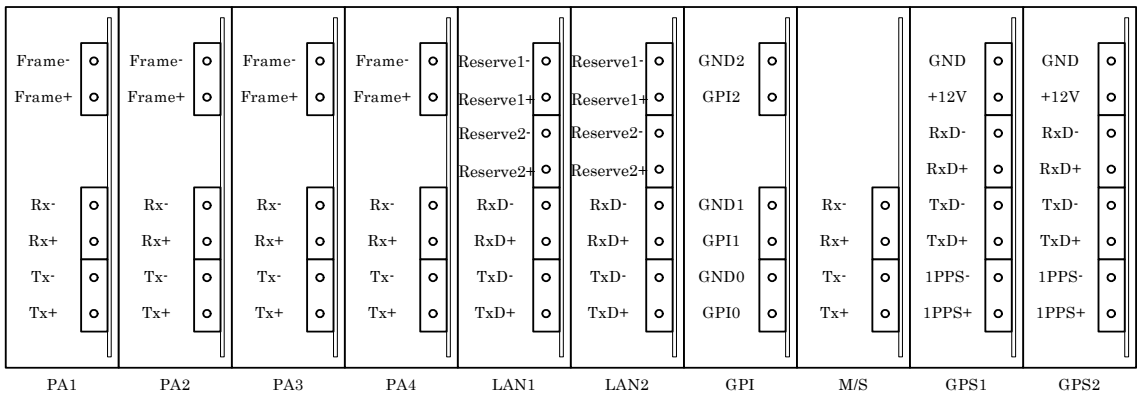

2.1.2.4.4 AC terminal

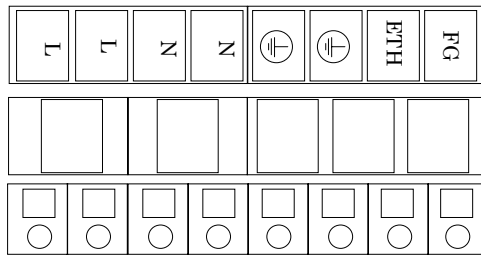

2.1.2.4.5 Display LED and Connector

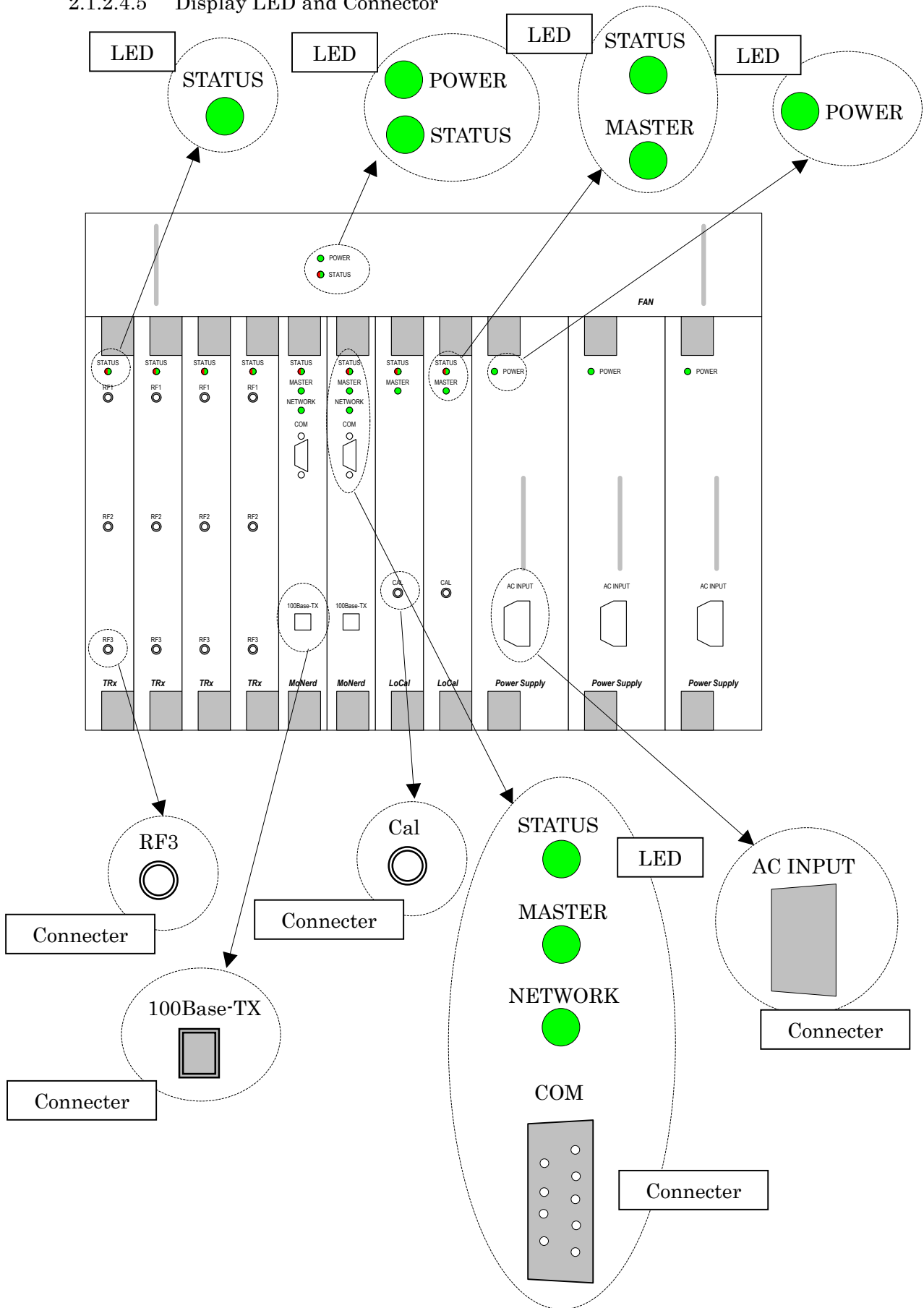

2.1.3 Connection diagram
2.1.3.1 PA unit - Antenna

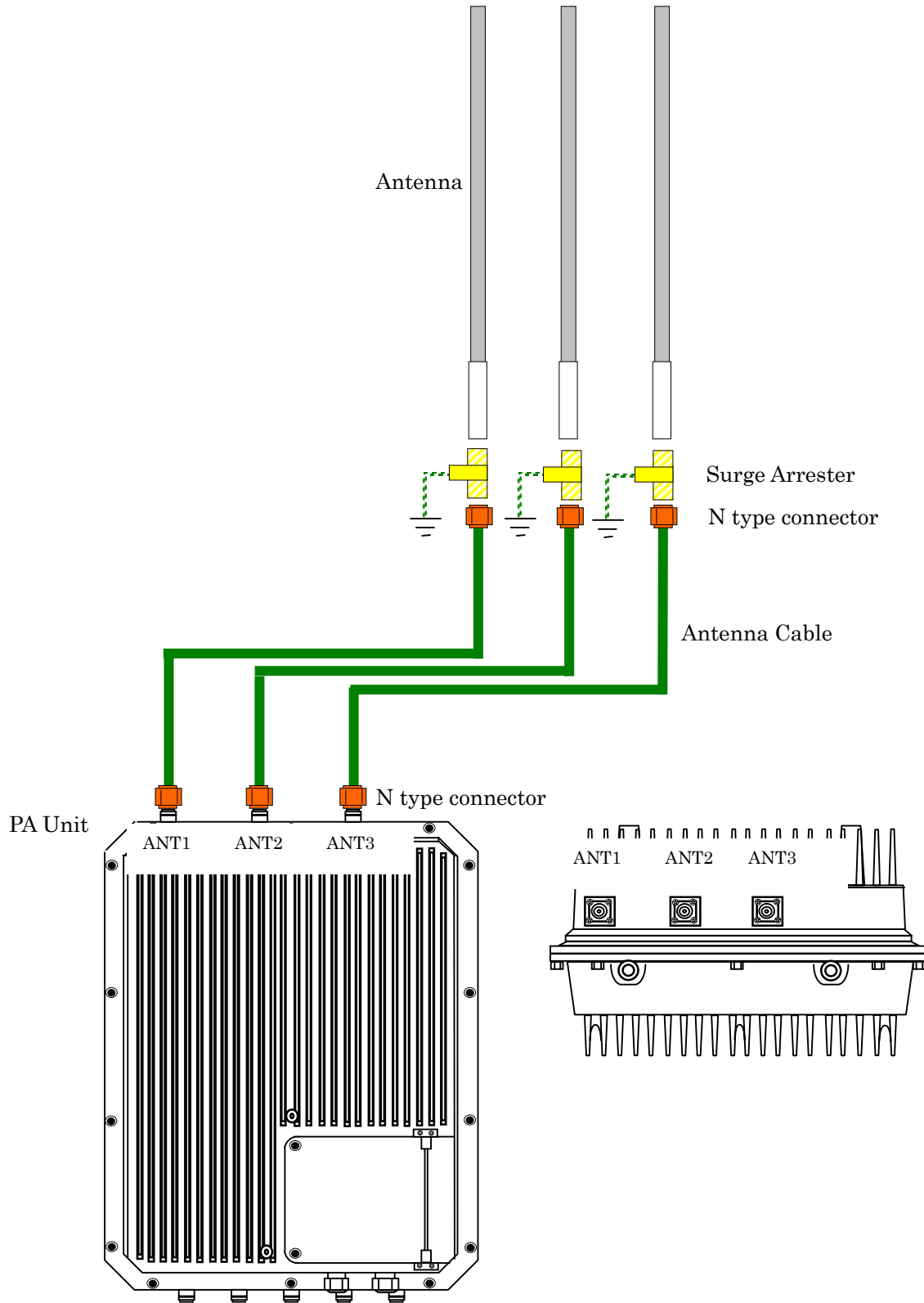

2.1.3.2 PA unit-Base unit
 2.1.3.2.1 Star connection
 2.1.3.2.1.1 Base unit – PA unit1,2

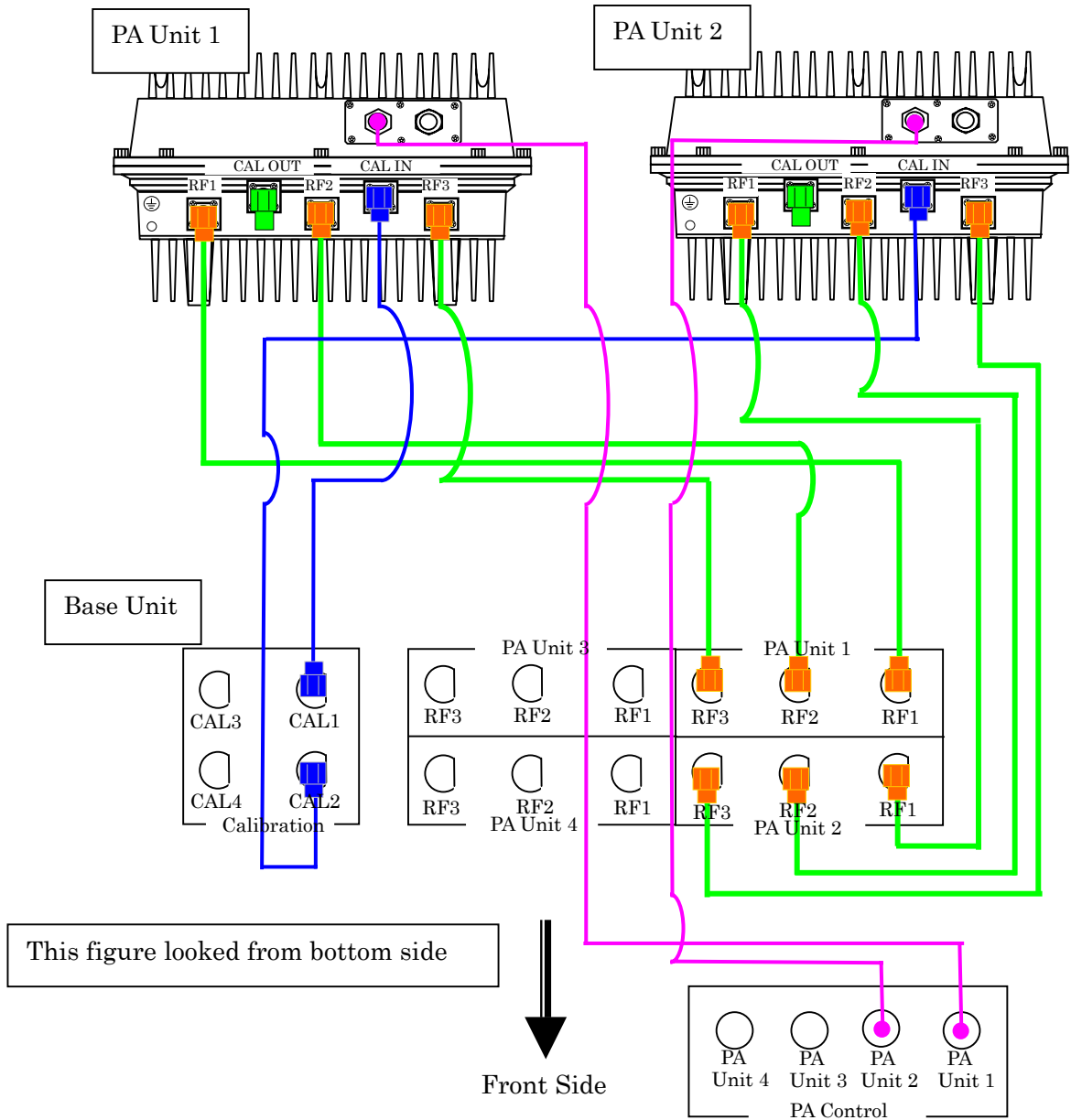





This figure looked from bottom side

Front Side

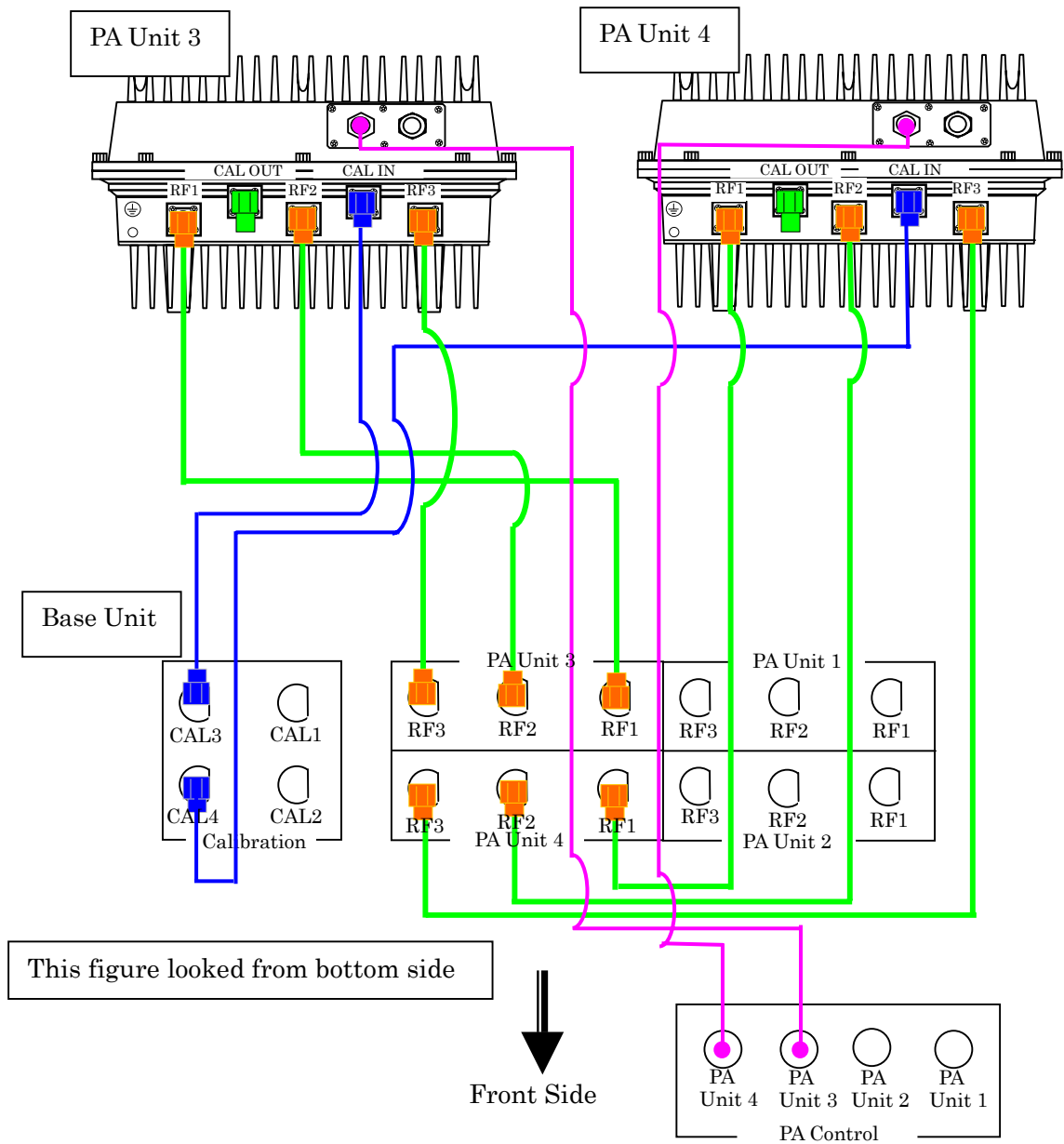
- PU-BU RF Cable w/ NP Connectors
- Calibration Cable w/ TNCP Connectors
- PA Control Cable w/ 232D
- TNCP type Terminator

2.1.3.2.1.2 Base unit – PA unit3,4



-  PU-BU RF Cable w/ NP Connectors
-  Calibration Cable w/ TNCP Connectors
-  PA Control Cable w/ 232D
-  TNCP type Terminator



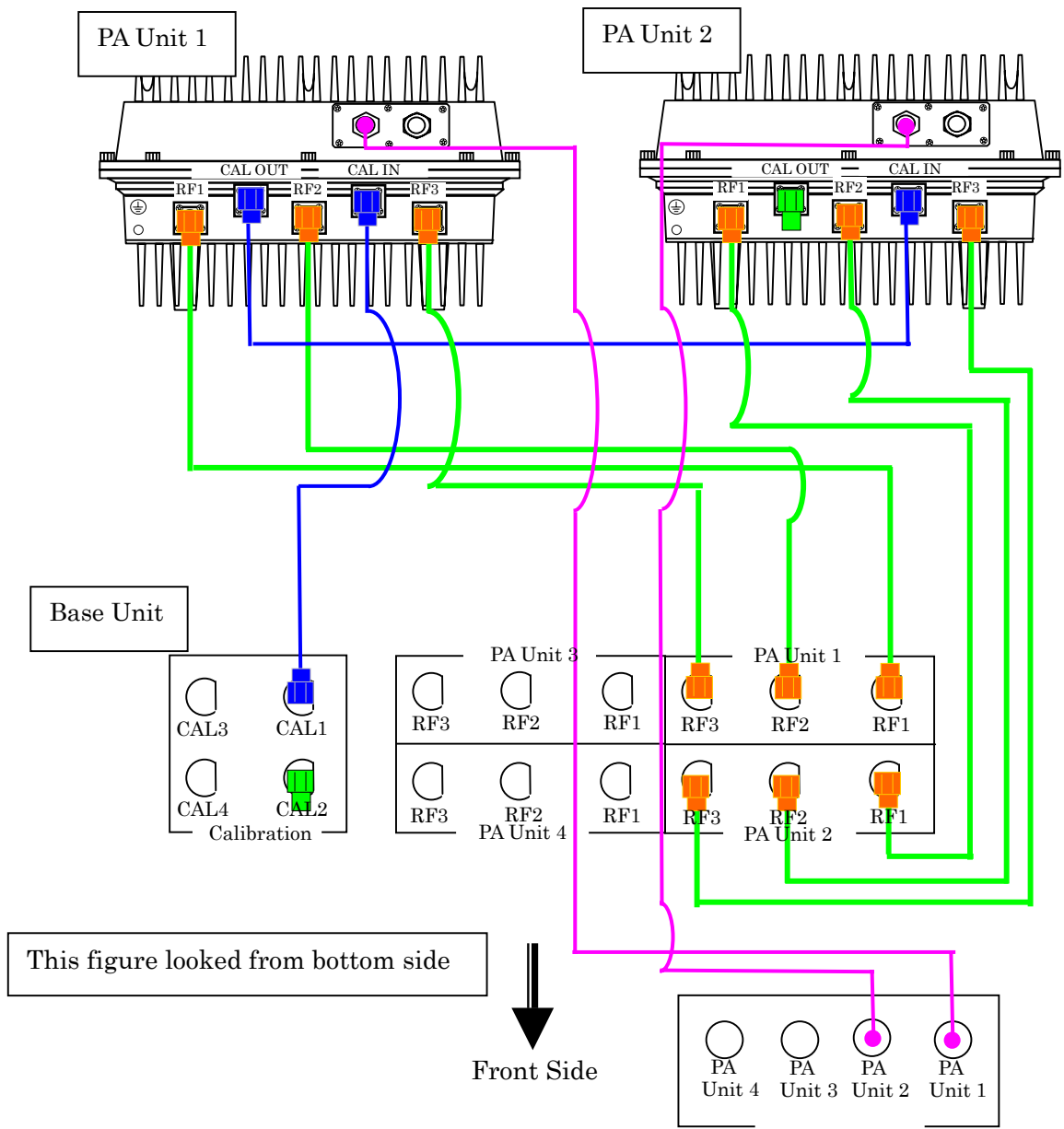

2.1.3.2.2 Daisy-chain connection
 2.1.3.2.2.1 Base unit-PA unit1,2

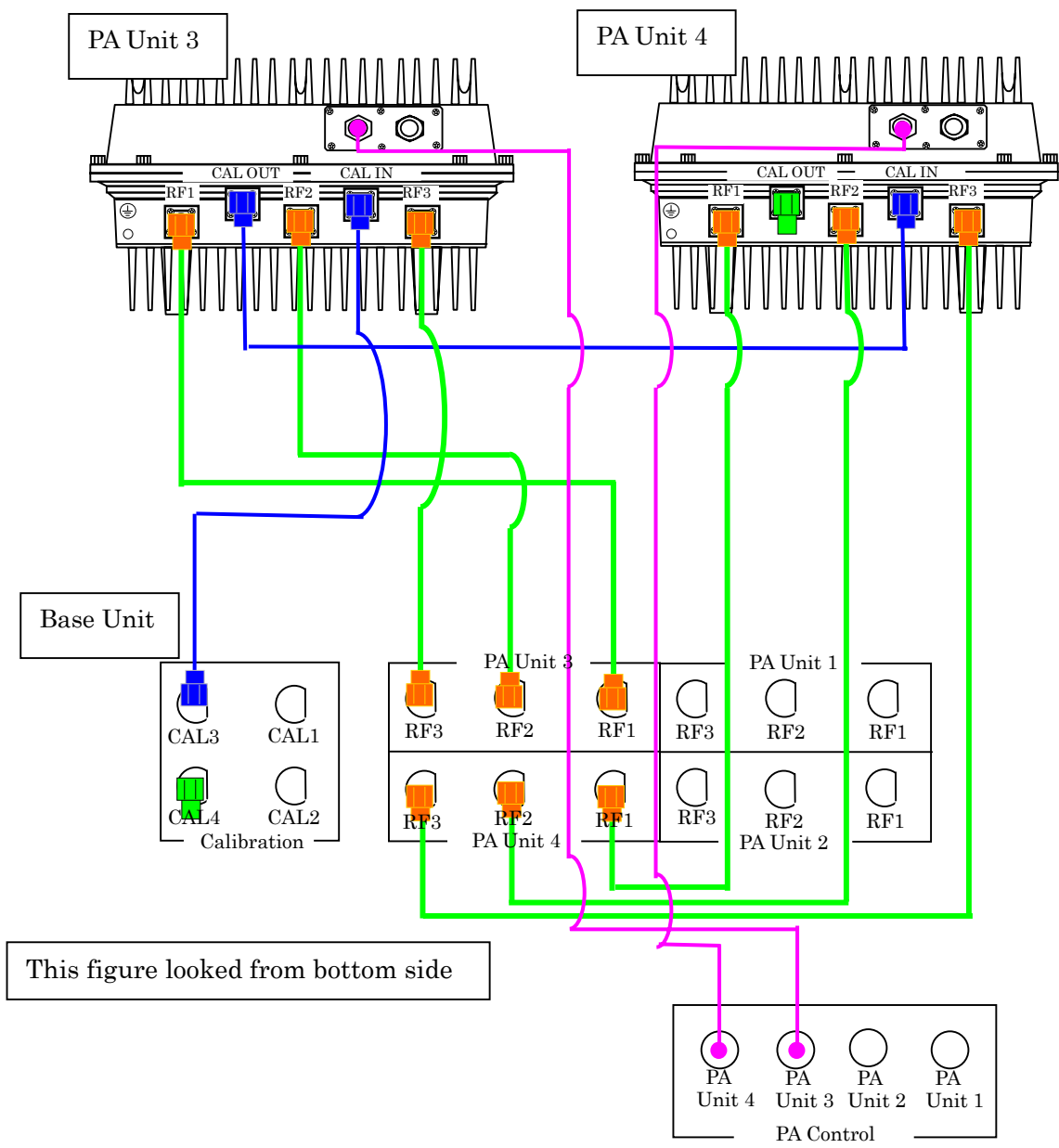

- PU-BU RF Cable w/ NP Connectors
- Calibration Cable w/ TNCP Connectors
- PA Control Cable w/ 232D
- TNCP type Terminator

2.1.3.2.2.2 Base unit – PA unit3,4



-  PU-BU RF Cable w/ NP Connectors
-  Calibration Cable w/ TNCP Connectors
-  PA Control Cable w/ 232D
-  TNCP type Terminator

2.1.3.3 Base unit – Other equipment

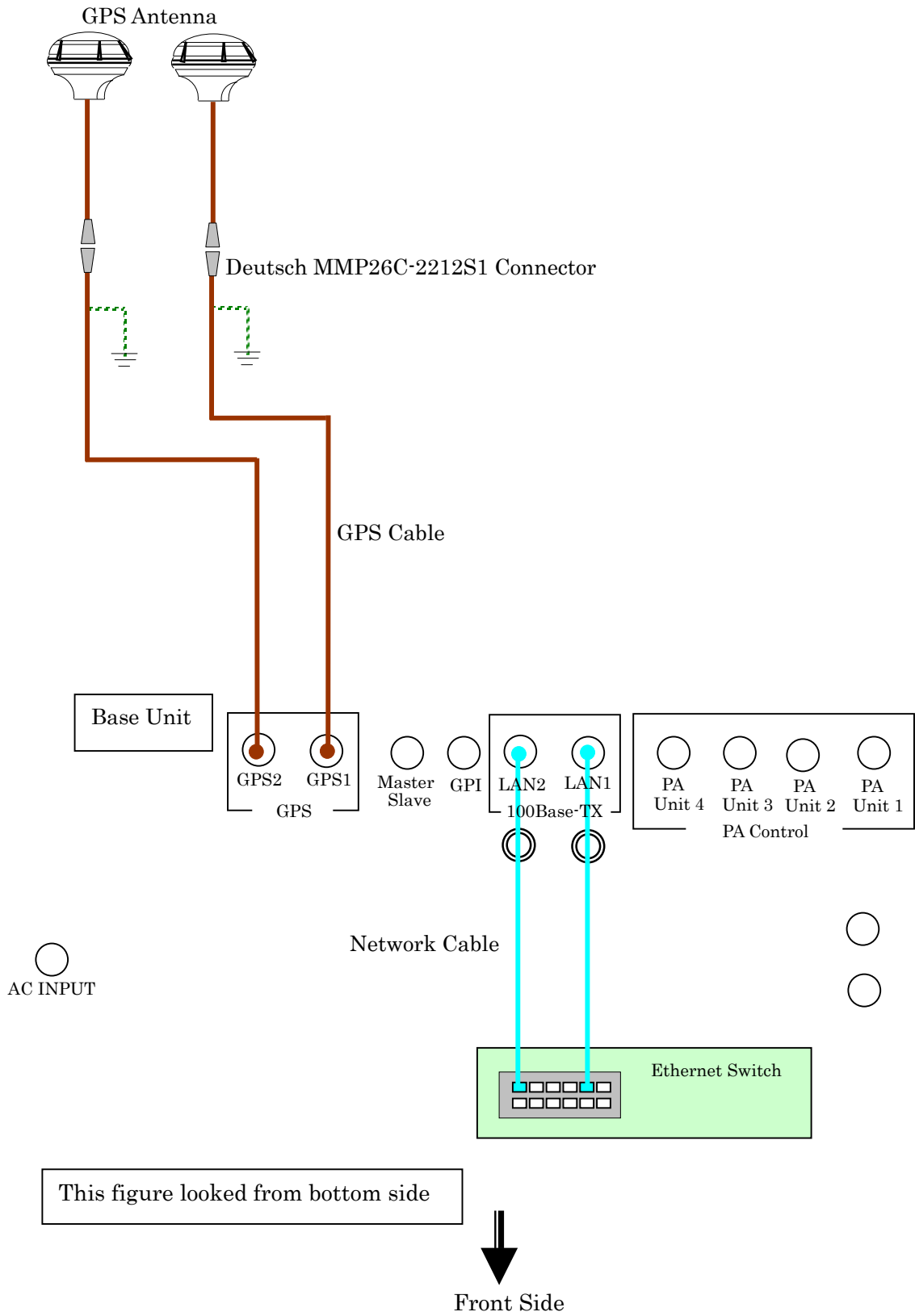

2.1.4 Pin assignment of cables/connectors

2.1.4.1 AC Power supply cable

PA Unit AC Terminal

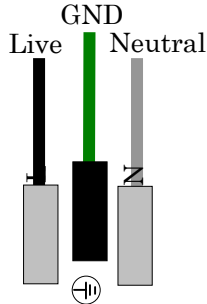

Base Unit AC Terminal

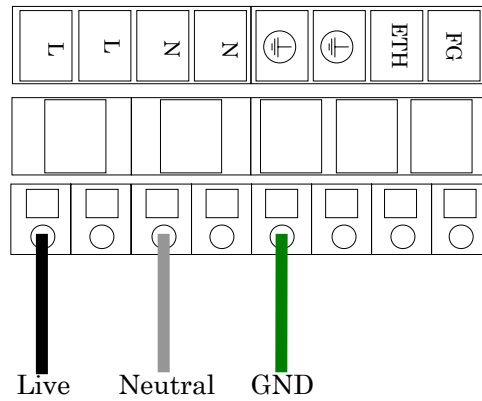

2.1.4.2 PA control cable

PA Unit side



PA Control Cable

Base Unit Surge Board

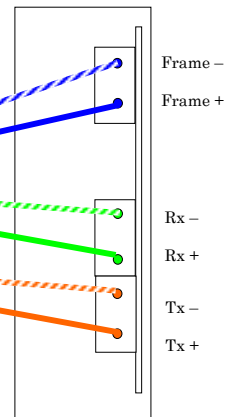

PA unit	Connection place	Base unit
TXD +	→	Rx +
TXD -	→	Rx -
RXD +	←	Tx +
RXD -	←	Tx -
FS +	←	Frame +
FS -	←	Frame -

2.1.4.3 Network cable

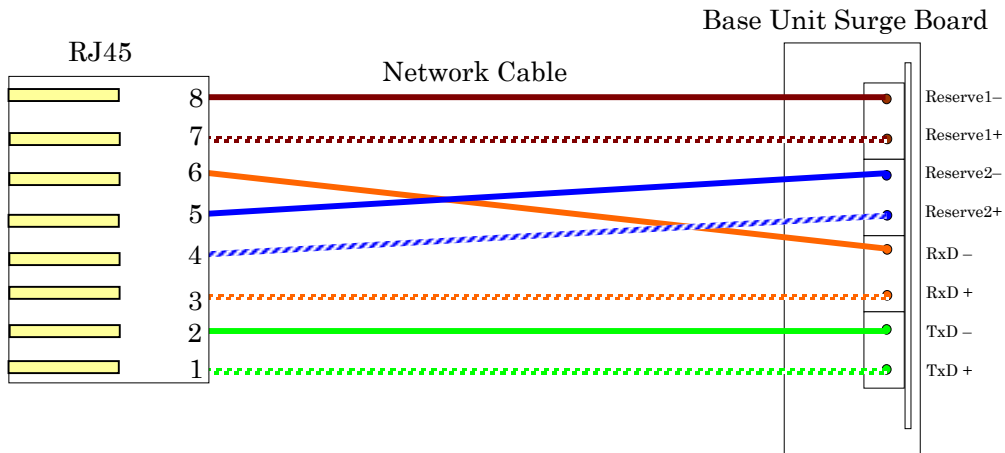

2.1.4.4 GPS cable

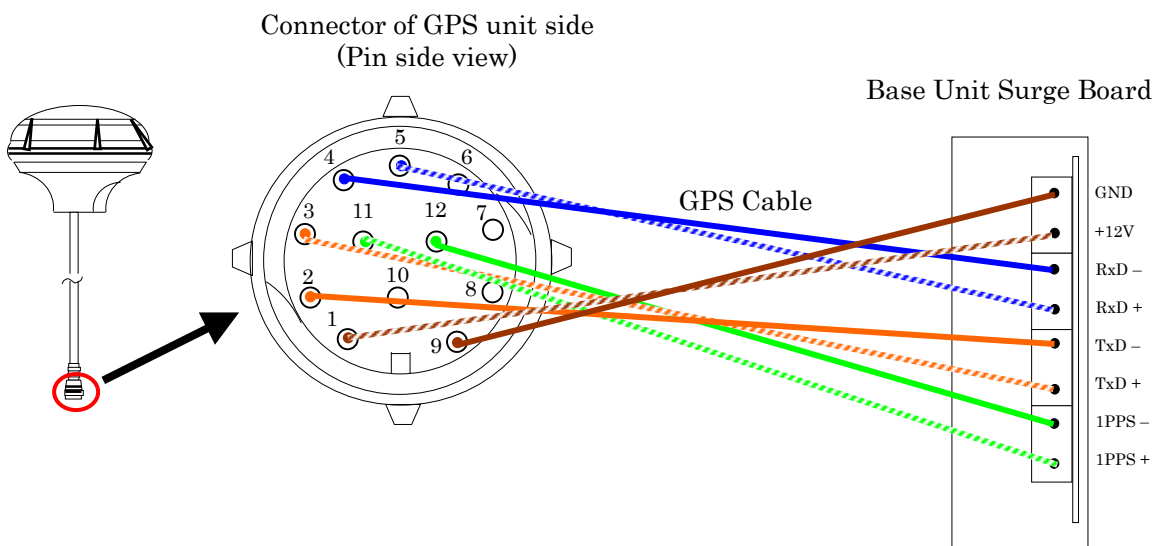

GPS connector pin No.	Connection place	Base Unit Surge Board
No.1	————	+ 12
No.2	————	TxD –
No.3	————	TxD +
No.4	————	RxD –
No.5	————	RxD +
No.6	————	NONE
No.7	————	NONE
No.8	————	NONE
No.9	————	GND
No.10	————	NONE
No.11	————	1PPS +
No.12	————	1PPS –

2.1.4.5 GPI cable

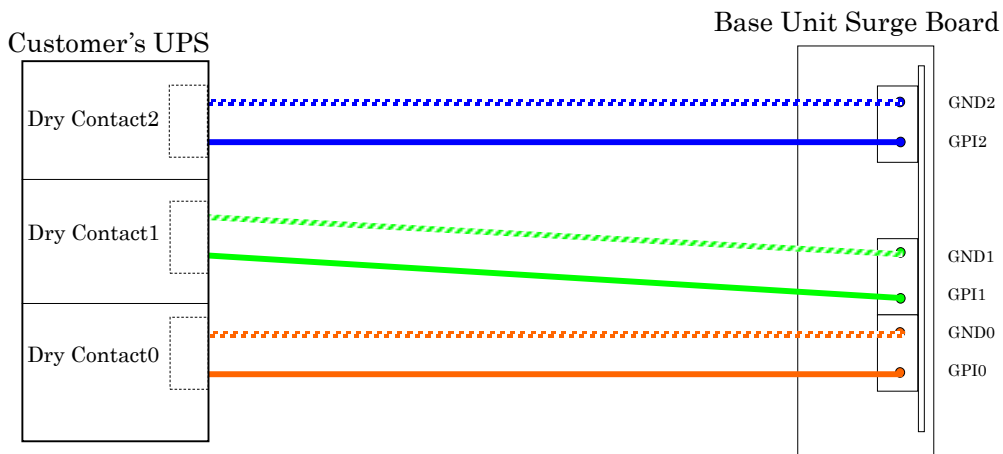

Customer's UPS	Connection place	Base Unit
Dry Contact2	_____	GND2
	_____	GPI2
Dry Contact1	_____	GND1
	_____	GPI1
Dry Contact0	_____	GND0
	_____	GPIO

2.1.4.6 Master/Slave cable

Master Base Unit Surge Board

Slave Base Unit Surge Board

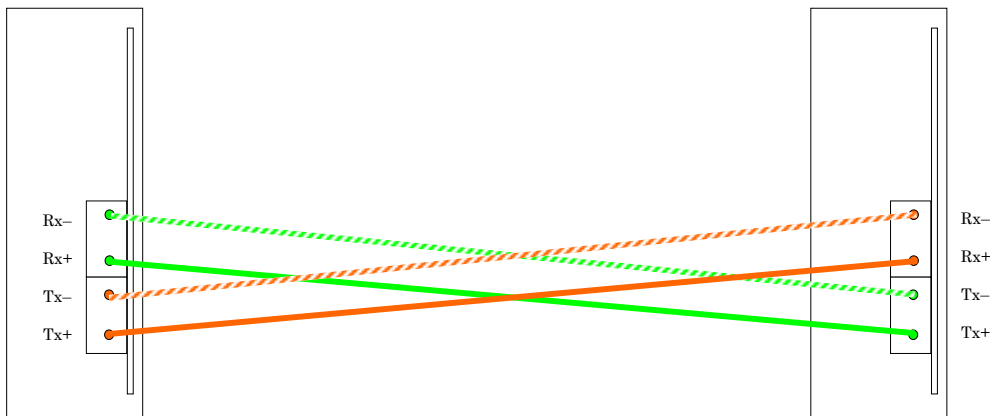

Master Base Unit	Connection place	Slave Base unit
Tx +	_____	Rx +
Tx -	_____	Rx -
Rx +	_____	Tx +
Rx -	_____	Tx -

2.2 Specifications

2.2.1 Hardware specifications

Number of antennas	12
Shape	PA unit
Dimensions	390 (W) x 256 (D) x 550 (H)
Weight	Approx. 40kg/unit
Power consumption	450W/unit
	Base unit
Dimensions	665 (W) x 665 (D) x 900 (H)
Weight	Approx. 100 kg
Power consumption	600W
	GPS unit
Dimensions	115 (diameter) x 96 (H)
Weight	Approx. 0.55kg/unit
Power consumption	1.8 W/unit
Network I/F	100Base-TX (Options are available.)
Installation environment	Outdoor/Indoor
Operating temperature	-20°C to +50°C

2.2.2 LED indicators

2.2.2.1 PA unit

Unit	Module	LED Name	Status	Mean	Comments
PA Unit	PA Control	STATUS	Off	Power Off	Ready for replacement
			Amber	Initializing/operation suspended	
			Green	Normal operation	
			Red	Abnormal	

2.2.2.2 Base unit

Unit	Module	LED Name	Status	Mean	Comments	
Base Unit	TRx	STATUS	Off	Board is ready for removal		
			Amber	Initializing/operation suspended		
			Green	Normal operation		
			Red	Abnormal		
	MoNerd	STATUS	Off	Board is ready for removal		
			Amber	Initializing		
			Green	Normal operation		
			Red	Abnormal		
		MASTER	Off	Slave is operating		
			Amber	Initializing		
			Green	Master is operating		
		NETWORK	Off	Network is abnormal		
			Amber	Initializing		
			Green	Network is alive		
		LoCal	STATUS	Off	Board is ready for removal	
				Amber	Initializing	
	Green			Normal operation		
	Red			Abnormal		
	MASTER		Off	Slave is operating		
			Green	Master is operating		
	Power Supply	STATUS	Off	Abnormal		
			Green	Normal operation		
	FAN	POWER	Off	Power is abnormal		
			Green	Power is normal		
STATUS		Amber	Initializing			
		Green	Normal operation			
		Red	Abnormal			

2.2.3 Accessories

2.2.3.1 PA unit

Accessory name	Quantity	Purpose of use
Eyebolt M10	2	Fixed on the top of PA Unit and used for transporting or fixing the main body.
Cap bolt M10	2	Fixed on the top of PA Unit and used for waterproof.

2.2.3.2 Base unit

Accessory name	Quantity	Purpose of use
Eyebolt M12	4	Fixed on the top of Base Unit and used for transporting or fixing the main body.
TNC terminating connector	4	To terminate the unconnected portion of calibration cable.
FAN tray fixing screw	6	Screw for fixing FAN tray
BU door key	2	Key for locking Base Unit door
L-shaped wrench for hexagonal hole	1	For tightening or removing a Base panel fixing screw.

2.2.4 Cable specification

Reference value of cable attenuation: FSJ1-50A → 0.277dB/m, FSJ2-50 → 0.191dB/m, FSJ4-50B → 0.171dB/m, at 1.9GHz made by Andrew

Type of cable	Purpose of use	Specifications	Q'ty
Antenna cable	From PA unit to Antenna	Recommend the attenuation less than 1dB. e.g. The cable equivalent to FSJ2-50 → Length: within 5m	12
PU-BU RF cable	From Base unit to PA unit	Keep the attenuation less than 13dB. e.g. The cable equivalent to FSJ1-50A → Length: within 46.5m FSJ2-50 → Length: within 68m FSJ4-50B → Length: within 76m	12
AC power cable	From PA unit to Breaker	Copper-shielded cable (3 lines) Cross-section: 1.25 - 2.0mm ² Diameter over jacket: 7 - 10.5mm	4
	From Base unit to Breaker	Copper-shielded cable (3 lines) Cross-section: 1.25 - 2.5mm ² Diameter over jacket: 7-10.5mm	1
Calibration cable	From Base unit to PA unit	Star connection Keep the attenuation less than 21dB. Disparity of the longest cable and the shortest cable is kept within 3dB in attenuation. e.g. The cable equivalent to FSJ1-50A → Length: within 75.5m	4
		Daisy-chain connection Keep the attenuation less than 15dB. Disparity of the longest cable and the shortest cable is kept within 3dB in attenuation. e.g. The cable equivalent to FSJ1-50A → Length: within 54m	2
	From PA unit to PA unit (Daisy-chain connection only.)	Keep the attenuation less than 3dB. e.g. The cable equivalent to FSJ1-50A → Length: within 10.5m	2

PA control cable	From Base unit to PA unit	Copper-shielded twist pair cable (4 pairs or more) Diameter: 0.5mm or 0.65mm Length: within 75m Diameter over jacket: 7-10.5mm	4
Network cable	From Base unit to Ethernet Switch or Router	Copper-shielded twist pair cable (4 pairs or more) Diameter: 0.5mm or 0.65mm Length: within 100m Diameter over jacket: 7-10.5mm	2
GPS cable	From Base unit to GPS unit	Copper-shielded twist pair cable (4 pairs or more) The maximum allowable end to end resistance is 5.4Ω or less. AWG24 (7/0.203) or AWG26 (7/0.16) Diameter over jacket: 7-10.5mm The example of reference: The case of 84.21Ω (AWG24)/km is 64m or 133.9Ω (AWG26)/km is 40m.	2
GPI cable	From UPS to Base unit	Copper-shielded twist pair cable (3pairs or more) Diameter: 0.5mm or 0.65mm Diameter over jacket: 7-10.5mm Length: within 100m	1
Master/Slave cable	From Master Base unit to Slave Base unit	Copper-shielded twist pair cable (3pairs or more) Diameter: 0.5mm or 0.65mm Diameter over jacket: 7-10.5mm Length: within 100m	1
Ground cable	PA unit to Ground	Soft copper twist cable of more than 6mm ² Reference resistance: Less than 3.1Ω/km (at 70 degrees in Celsius)	4
	BU unit to Ground	Soft copper twist cable of more than 6mm ² Reference resistance: Less than 3.1Ω/km (at 70 degrees in Celsius)	1
	GPS unit to Ground	Soft copper twist cable of more than 6mm ² Reference resistance: Less than 3.1Ω/km (at 70 degrees in Celsius)	2

2.2.5 Other Parts specification

Type of parts	Purpose of use	Specifications	Q'ty
N type RF connector	PU-BU RF cable	N type Male	24
	Antenna cable		12
TNC type connector	Calibration cable	TNC type Male	8
TNC type Terminator	PA unit CAL port (CAL OUT)	TNC type Male	4
232D connector	PA Control cable at both sides	232D-02S1B-DA2	24
	Network cable in surge box of BU		8
	GPS cable in surge box of BU		8
	GPI cable in surge box of BU		3
	M/S cable in surge box of BU		2
MMP connector Plug Contact Boot	GPS cable at GPS side	Deutch Plug: MMP26C-2212S1	2
		Contact: 6862-201-22278,12pcs	2
		Boot: 6810-204-2001	2
Surge Arrester	Equipment surge protection	N type Female/Female λ /4 Stub type Arrester or Gas Tube type Arrester	12
"O" shaped type Terminal	Grounding cable for PA unit	M6 type	4
	Grounding cable for Base unit	M6 type	1
	Grounding cable for GPS unit	M6 type	2
GPS mount adaptor	Fixing and Grounding for GPS	Specification of a screw part: 1.00-14UNS-2A	2

		Mounting pipe length: 520mm (Including screw part) Mounting pipe inside diameter: 20.5-21.5mm Hot-dip galvanized steel With Hex bolt (M6)
--	--	----------------------------------------------------------------------------------------------------------------------------------------------------------

2.2.6 Handling of cables

Install cables considering the possible flexibility, pressure resistibility, and stretching strength. Strength of the coaxial cable is shown below.

Items	FSJ1-50A	FSJ2-50	FSJ4-50B
Minimum Bending Radius	More than 25mm	More than 25mm	More than 32mm
Tensile Strength	68kg	95kg	80kg
Bending Moment	1.1N·m	2.3N·m	2.7N·m
Others	Don't bend Cable below -10 degrees in Celsius		

2.2.7 Tightening Torque

Appropriate cable diameters and Tightening Torque for Bushes and Connectors on each side are shown below.

Connecting point	Suitable diameter of the Cable	Tightening Torque of the Bush and Connector
Antenna connector (N type Connector)		1.96 to 2.94 N·m
Bush for AC power cable	7 to 10.5mm	2.45N·m
Bush for Network cable	7 to 10.5mm	2.45N·m
Bush for PA Control cable	7 to 10.5mm	2.45N·m
Bush for GPS cable	7 to 10.5mm	2.45N·m
Bush for GPI cable	7 to 10.5mm	2.45N·m
Bush for M/S cable	7 to 10.5mm	2.45N·m
PU-BU RF cable (N type connector)		1.96 to 2.94 N·m
Calibration cable (TNC type connector)		0.45 to 0.69N·m

2.2.8 Tools

Tool name	Specifications	Purpose of use
Monkey wrench	Max. opening 24 mm	For fixing hex nuts, etc.
Torque wrench Adjustable type torque wrench	1-5N·m 5-25N·m	For torque control.
Torque driver	1-5N·m	
Flat-head screwdriver	3 mm wide	For holding the cage clamp when connecting power cable to power terminal board.
Cross-shaped (Philips) screwdriver	No.1 No.2 No.3	For tightening or removing Cross-shaped (Phillips) screw.
Allen wrench	3mm	For opening or closing the Lid of PA Unit.
	10mm	For removing or installing Allen screws of Base Unit.
Hex lobe screwdriver T30	T30	For tightening or removing a tamper proof screw.
L-shaped wrench for hexagonal hole	Size 3 for M5	For tightening or removing a Base panel fixing screw. *1
Wrist strap F-50	F-50	For preventing static electricity when inserting or removing a board.
GPS connector assembly tools Crimping tool DANIELS MH860 Positioner Insertion and removal tool		For caulking MMP connector.
	M22520/7-01	
	M22520/7-06	
Insertion and removal tool	M81969/14-01	
Soldering iron	150W	Soldering a TNC type connector.

Base unit

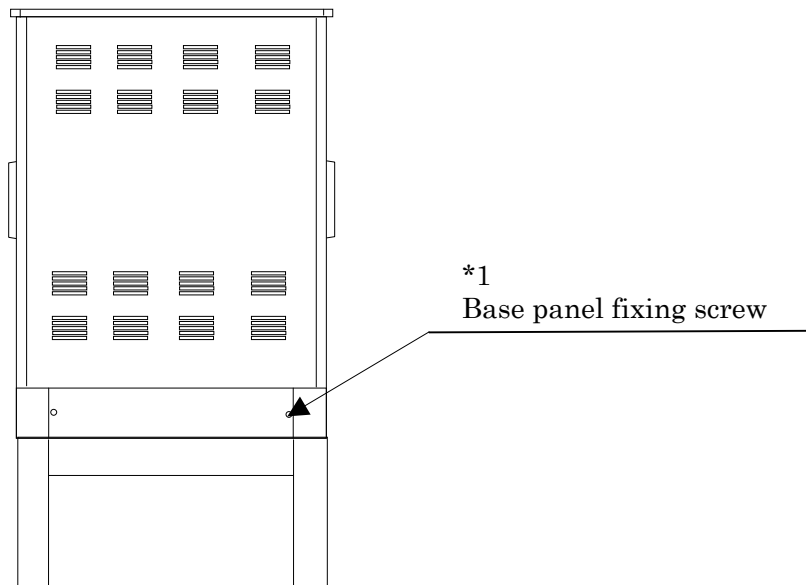

3 Installation

3.1 Installing Antenna System (Example)

Assemble the antenna base (H-section steel) on the place determined by site survey.

3.1.1 Installing the antenna pole

- 1) Fix the antenna base (H-section steel) by using bolts.

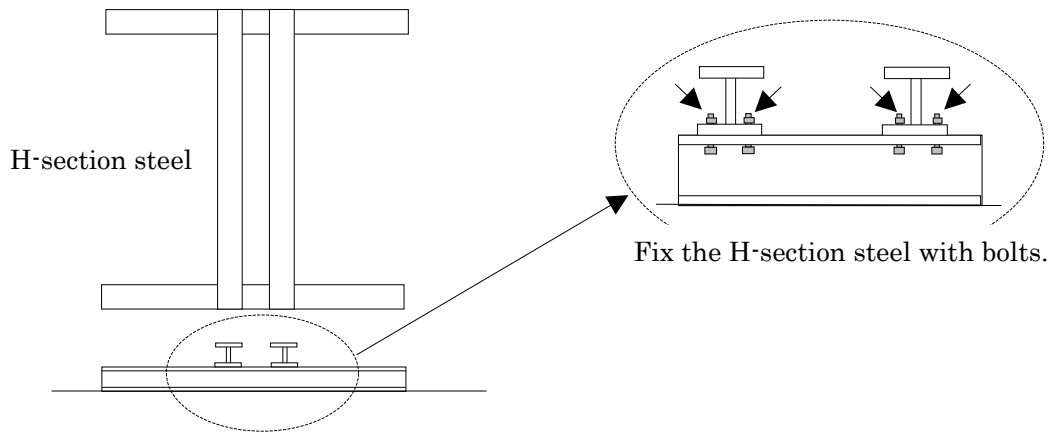

- 2) Fixing the antenna pole to the antenna base (H-section steel)

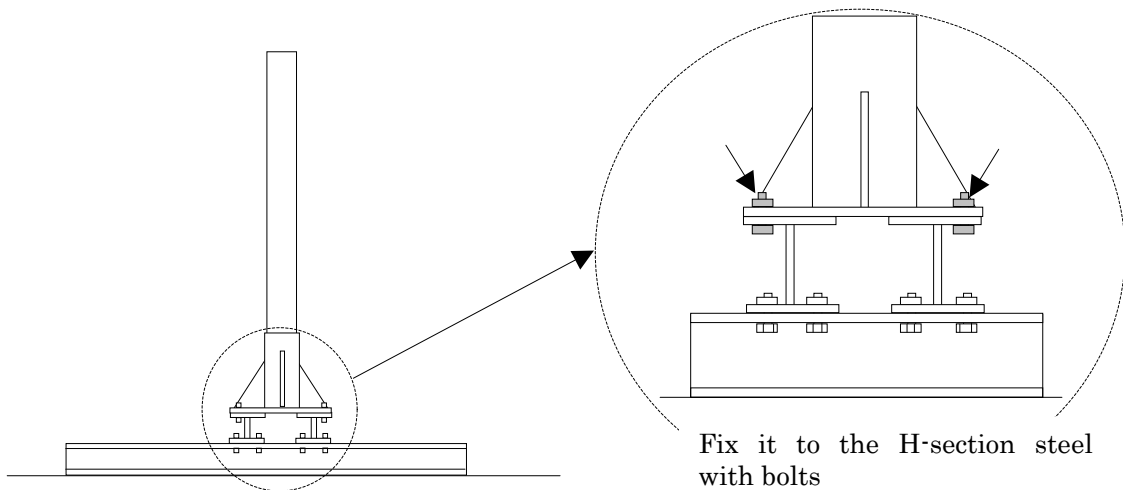

- 3) Fixing the mast to the antenna pole

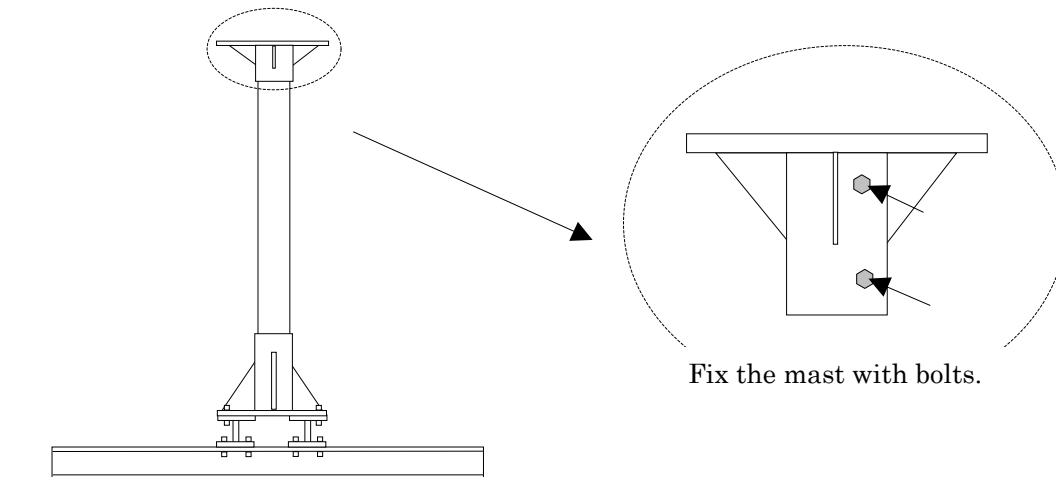

4) Fixing the antenna arm to the mast

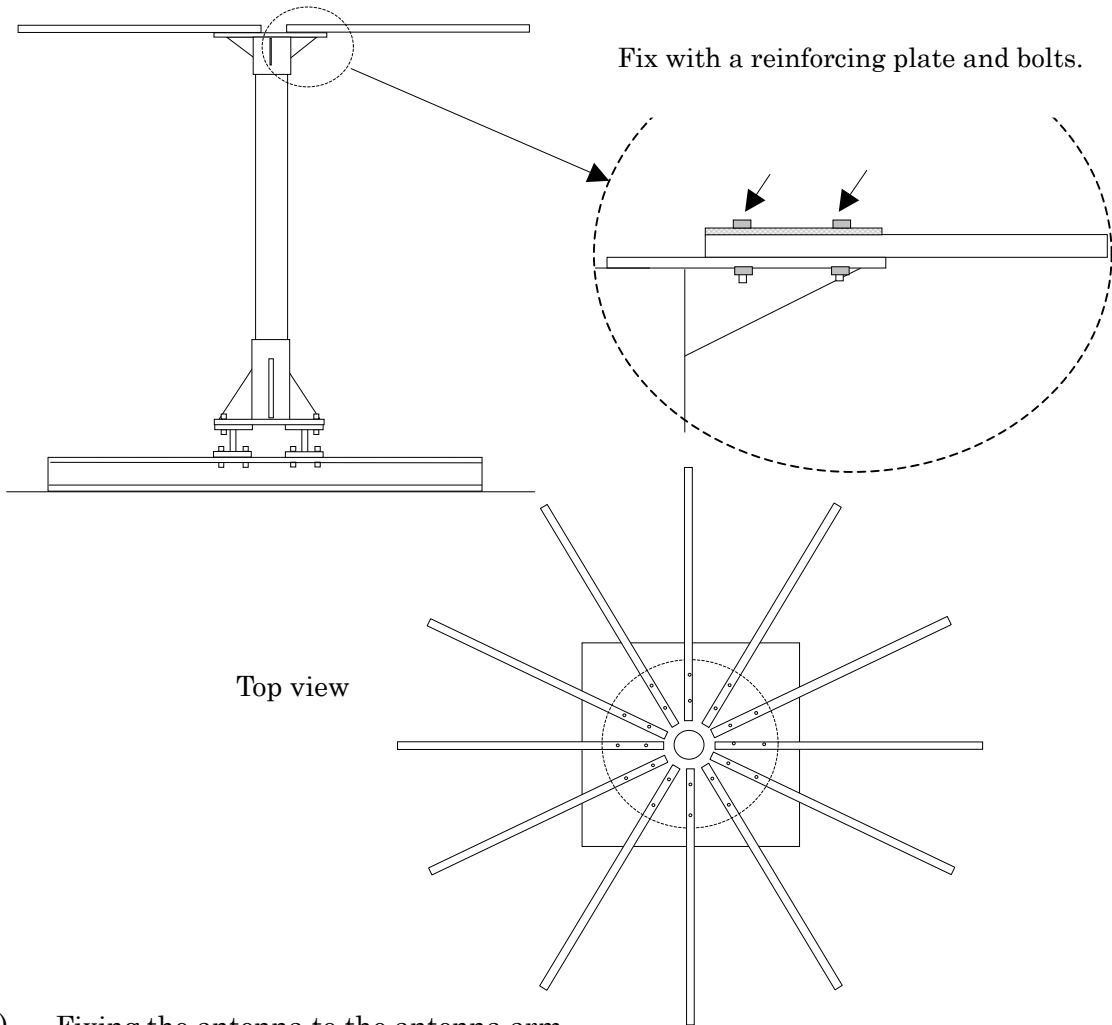

5) Fixing the antenna to the antenna arm

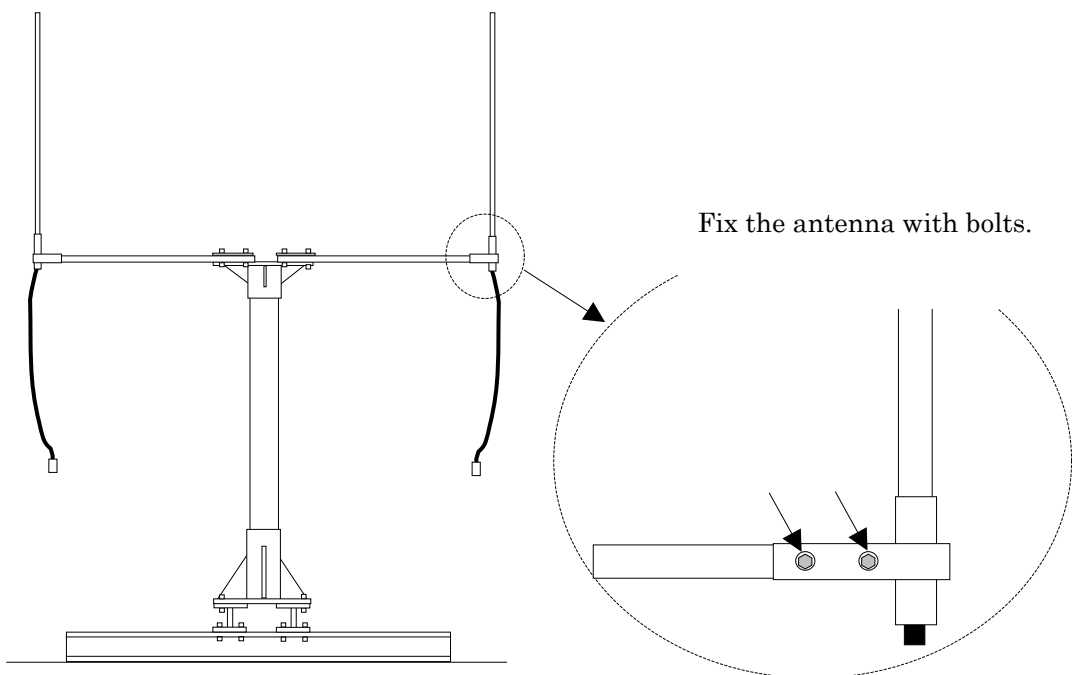

- 6) Connecting the surge arrester
Connect the surge arrester between the antenna cable connector and the extension cable.
→Tightening torque: 1.96 to 2.94N·m

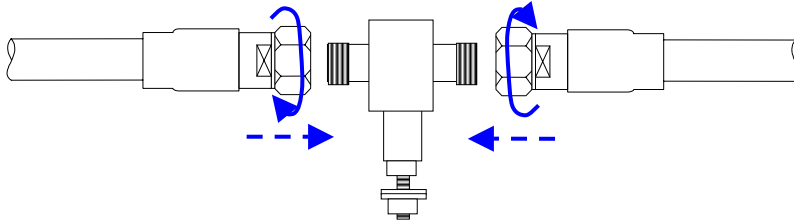

- 7) Waterproof treatment for the surge arrester connector

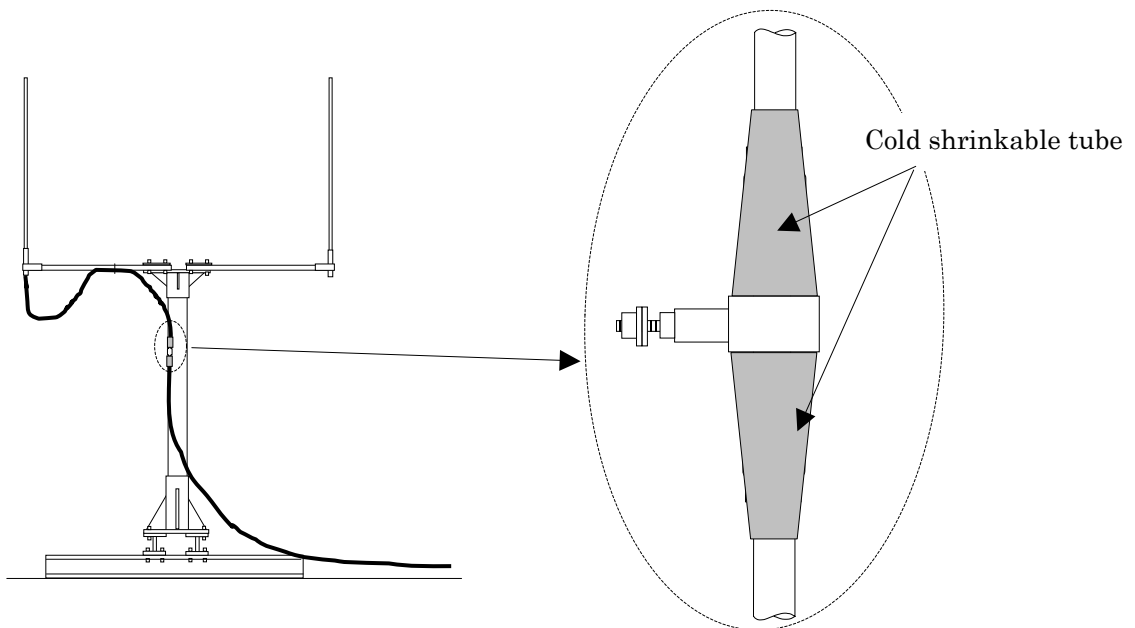

- 8) Connecting the surge arrester to the ground
Install a ground bar or use the grounding directly through the cable.

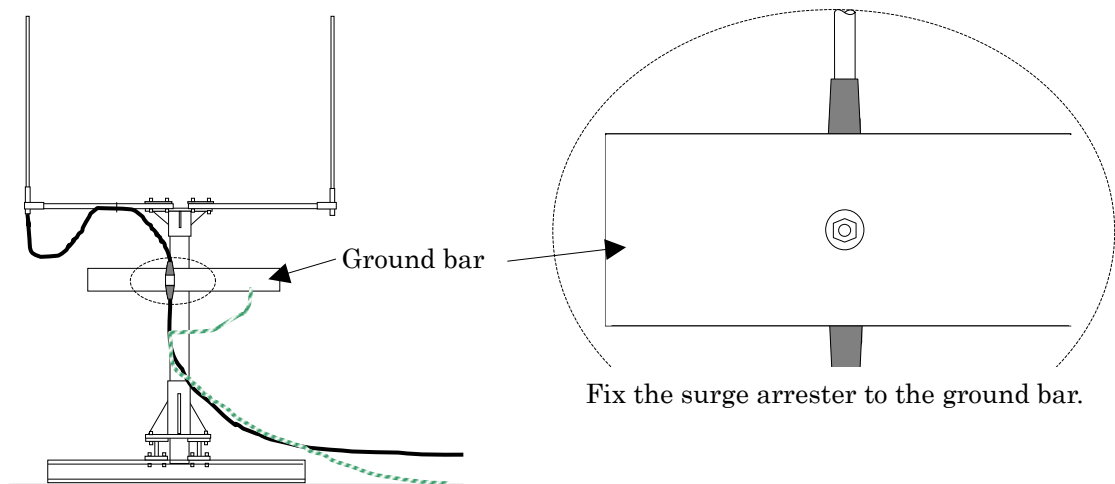

3.2 Installing PA Unit

3.2.1 Mounting and removing the Eyebolt

1) Mounting the Eyebolt

Insert the Eyebolt to the screw hole for the Eyebolt (M10) at the upper portion of the PA Unit and turn it to fix.

Eyebolt (M10) → Tightening torque: 4.41 to 5.39N·m

Cap bolt → Tightening torque: 2 to 3N·m

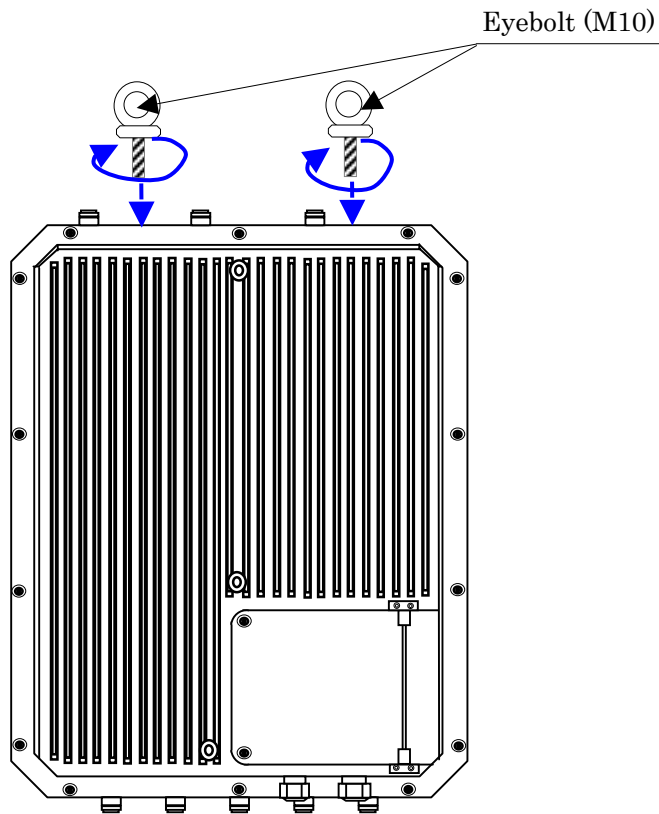
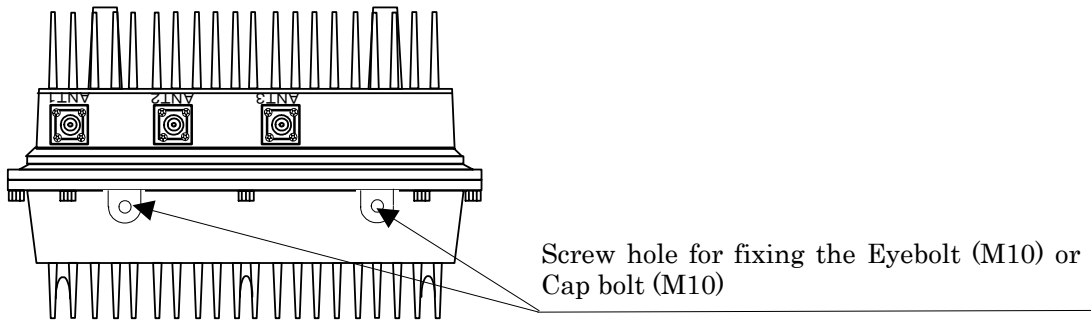

3.2.2 Mounting the PA Unit (Example)

When fixing the PA Unit to a fitting, tighten it with a specified torque. (Seven or more threads of the bolt must screw in and fit to the thread on the PA unit effectively.)

Recommending bolt: Hot-dip galvanized steel or Dacrotized finishing.

Tightening with excessive torque may cause broken screw.

1) Fixing the PA Unit and a mounting bracket

Put the PA Unit with its front down to prevent damage to the connector and attach the mounting bracket.

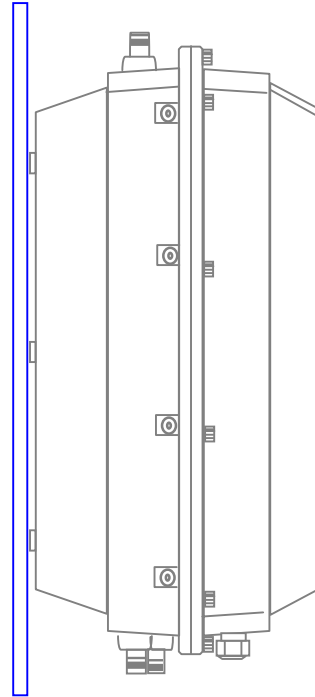
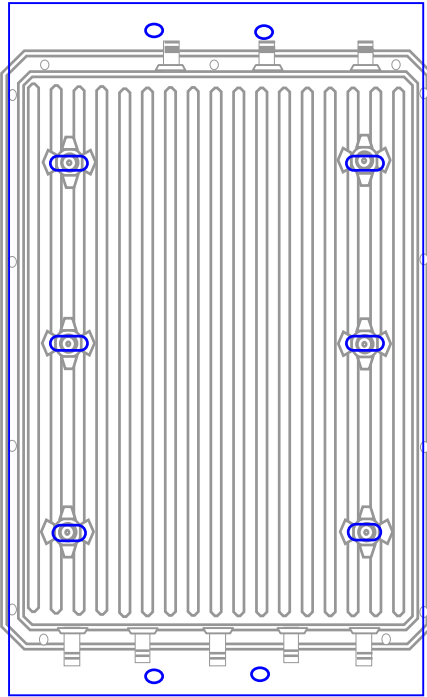

Fix it with bolts supplied with the mounting bracket for the PA Unit.

→Tightening torque: 22N·m to 27N·m

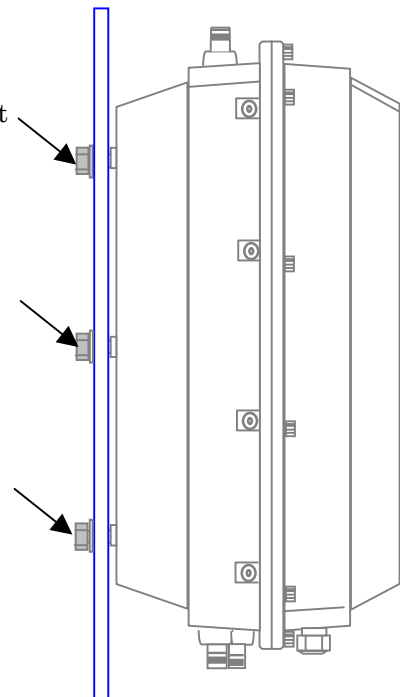

- 2) Fixing the mounting bracket
Attach the U bolts of the mounting bracket to the fixing plate and fix it with nuts.

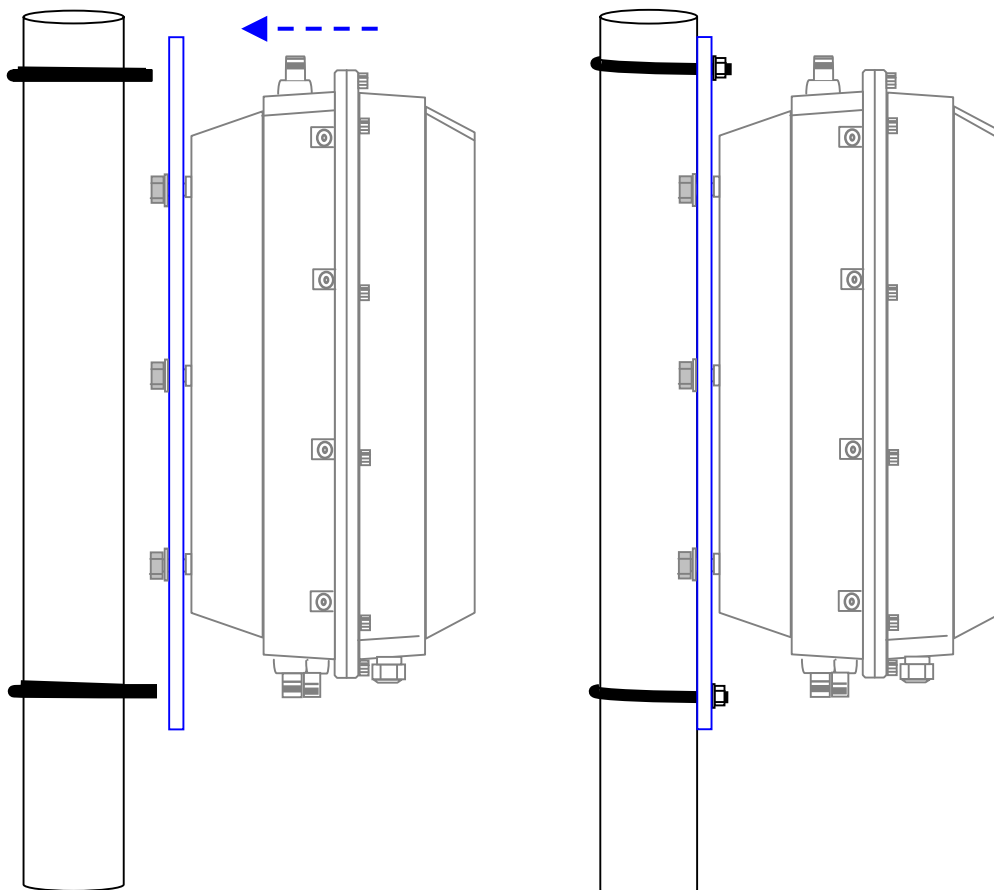

3.2.3 Connecting cables

3.2.3.1 Connecting the AC power supply cable

Before connecting the AC power supply cable, verify that the supply voltage of the power distributor is within the range of $\pm 15\%$ of the nominal voltage.

And distribute the AC power supply cable so that the power for each PA unit can be turned on or off separately through the breaker.

1) Opening/closing the Lid of the PA Unit

Loosen the hexagonal recessed bolts (2 places) on the Lid using a hexagon wrench (3 mm) and open it

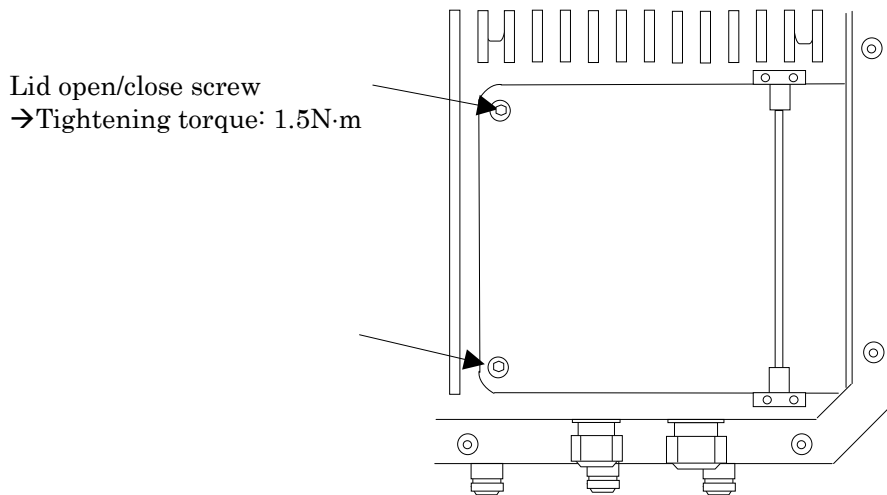

2) Removing the cable clamp for the AC power supply cable

Remove the cable clamp fixing screw (M4) with a “+” screwdriver and remove the cable clamp.

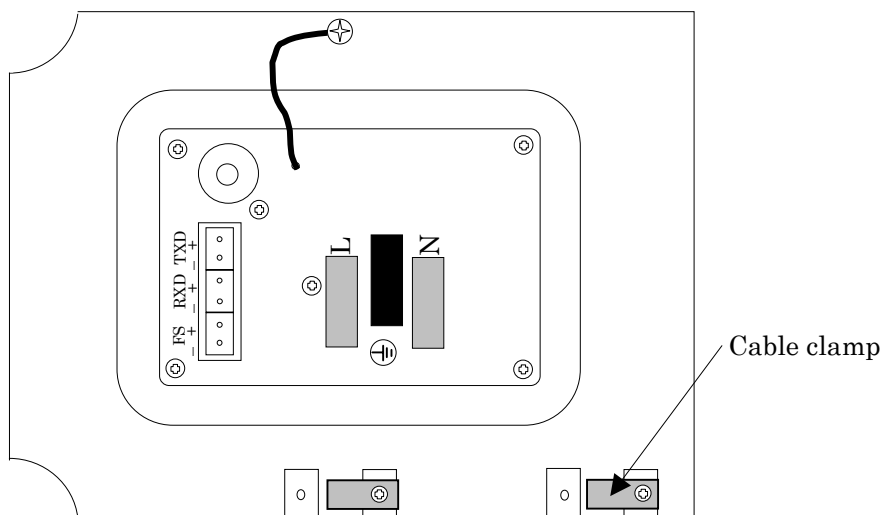

- 3) Removing the dome nut for the AC power supply cable
Remove the dome nut for the AC power supply cable at the bottom of the PA Unit and remove the cable packing.

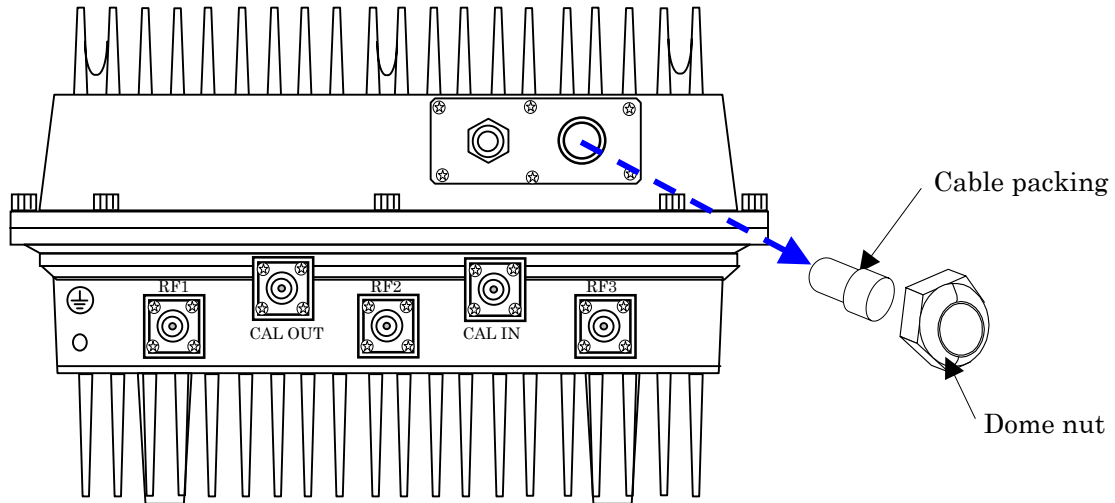

- 4) Pre-finishing the AC power supply cable
Put the AC power supply cable through the cold shrinkable tube, the dome nut and the cable packing in this order.
(See the following figure for the direction.)

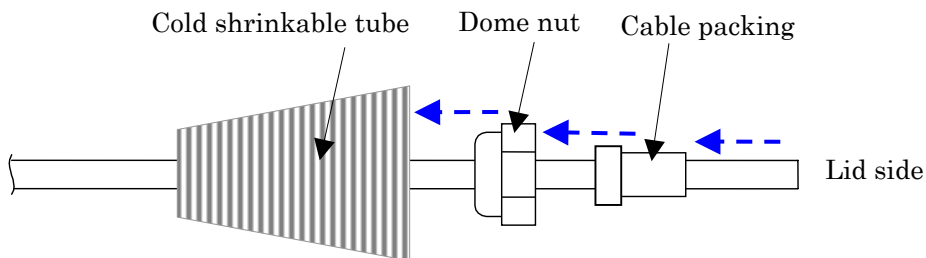

Peel the sheath off the AC power supply cable to expose the conductor.
→Peeling length of the sheath: 15 to 20 cm

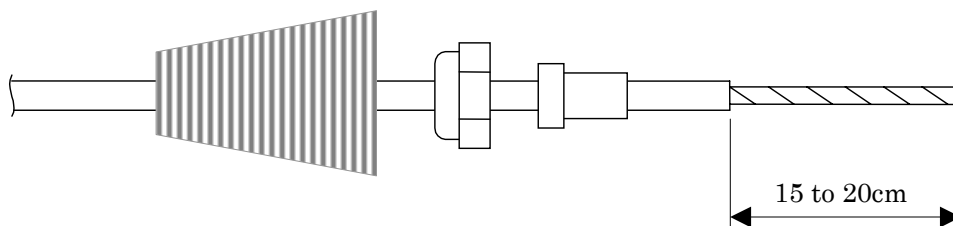

Loosen the copper shield and coil it around the conductor at the shield root part by more than 4 turns.

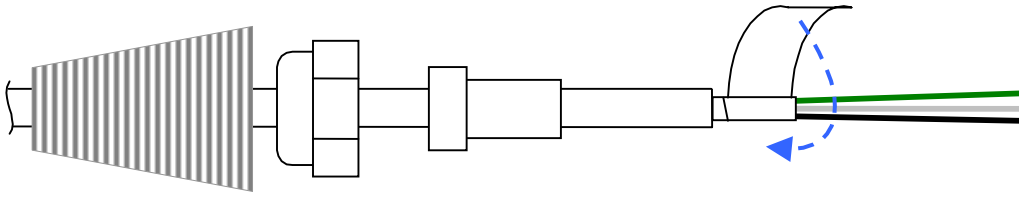

Peel the sheath off 3 conductors.
→ Peeling length of the sheath: 10 mm

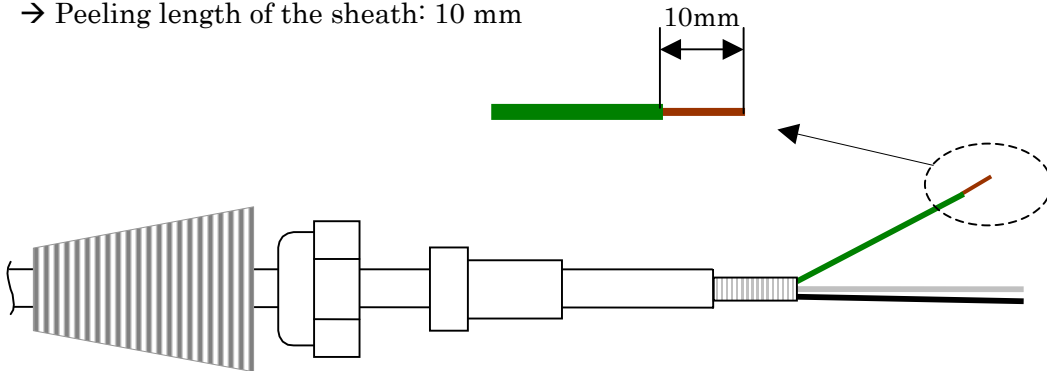

- 5) Inserting the AC power supply cable
Insert the AC power supply cable into the Lid through the bushing for the AC power supply cable.

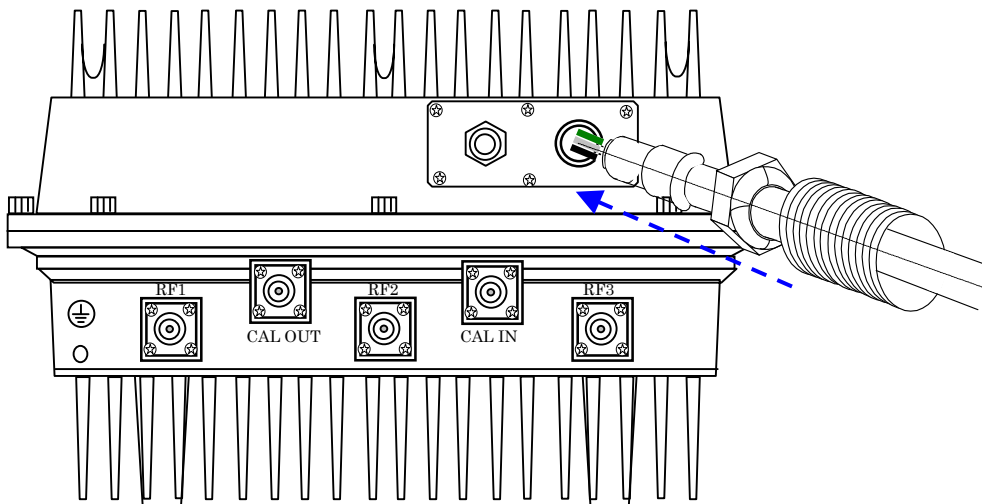

6) Fixing the cable clamp

Position the copper shield of the cable at the arrow marking in the following figure and fix it with the cable clamp and a fixing screw (M4).

→Tightening torque: 1.5N·m

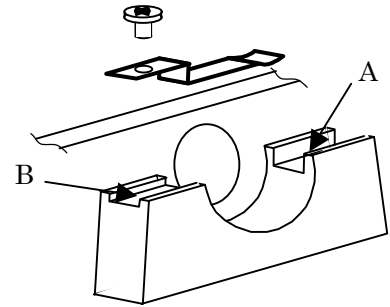
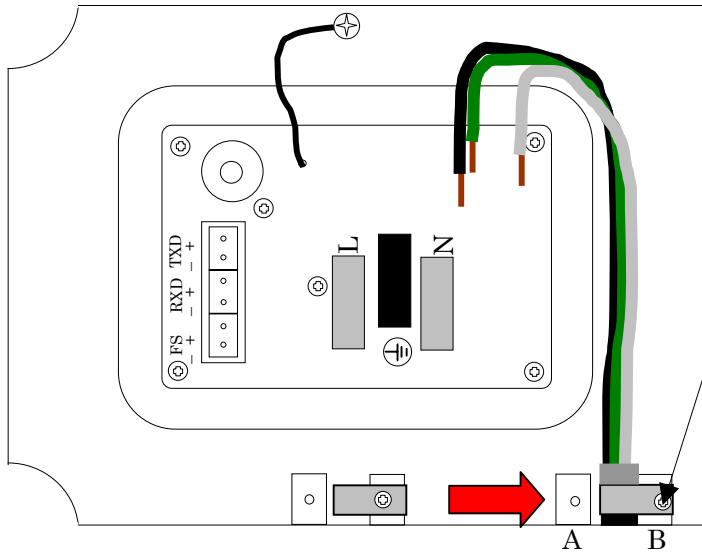

Fix the cable clamp with a fixing screw (M4).

The attachment position of a cable clamp changes by the diameter of a cable.

When the diameter of a cable is from 6 to 8mm, it attaches at A-side.

When the diameter of a cable is from 7 to 10.5mm, it attaches at B-side.

7) Tightening the dome nut

After inserting the cable packing, tighten the dome nut by hand and then retighten it using a torque wrench.

→Tightening torque: 2.45N·m

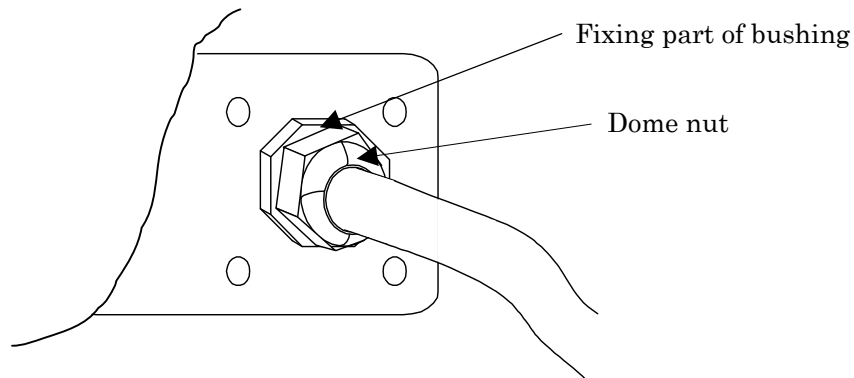

- 8) Connecting the AC power supply cable to the AC terminal
With keeping the AC terminal depressed by a finger, insert the AC power supply cable and then release the finger.
After insertion, verify that the cable cannot be removed.
In the following figure, Neutral, Ground and Live cables are arranged in this order from the right side.

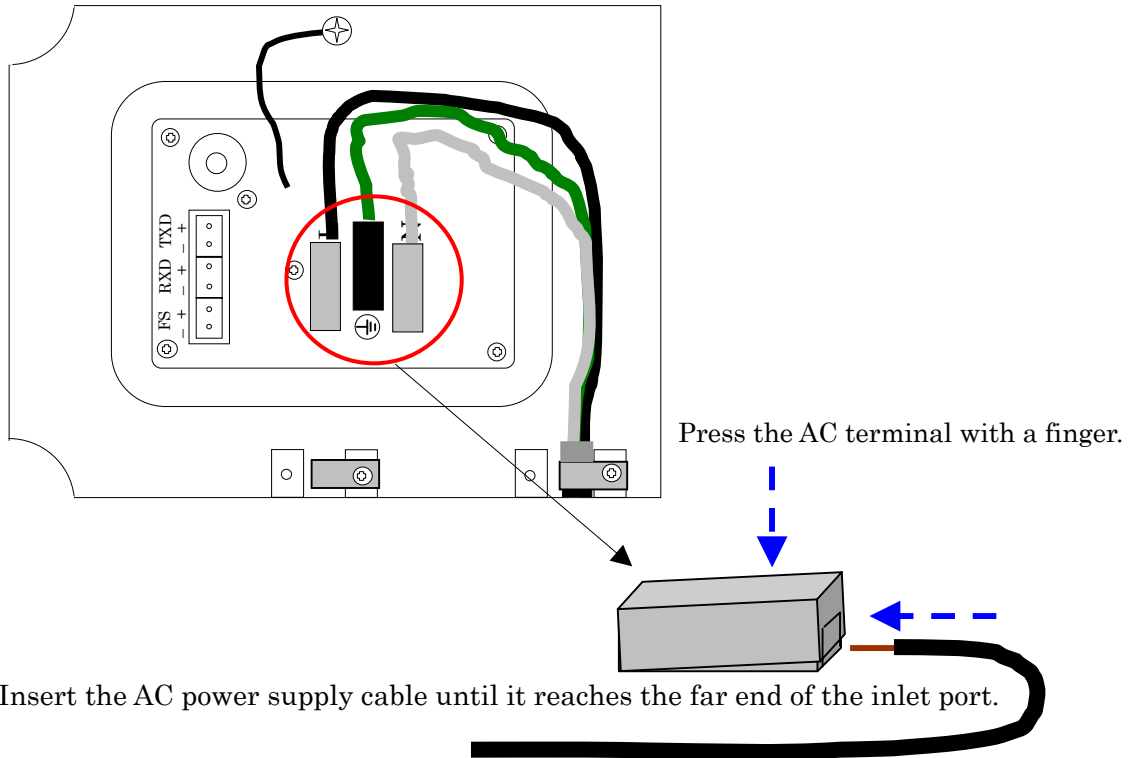

- 9) Treatment of the AC power supply cable
Form the AC power supply cable along the inside of the Lid so that the Lid does not clip the cable.

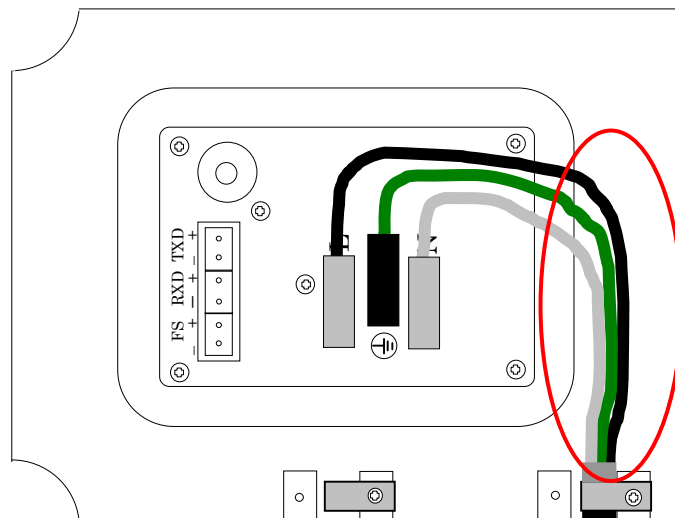

- 10) Waterproof treatment for the AC power supply cable connector
Cover the cold shrinkable tube over the root of the connector and shrink it.

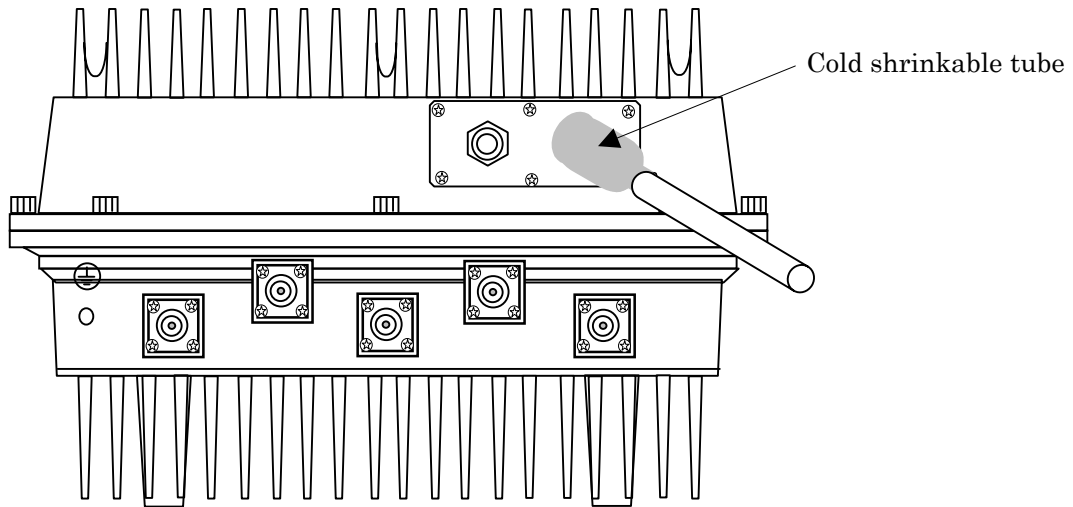

3.2.3.2 Connecting the grounding cable.

Crimp the grounding cable (More than 6mm²) to the terminal and fix the bolt (M6) with it.

→ Tightening torque: 3.29 to 4.12N·m

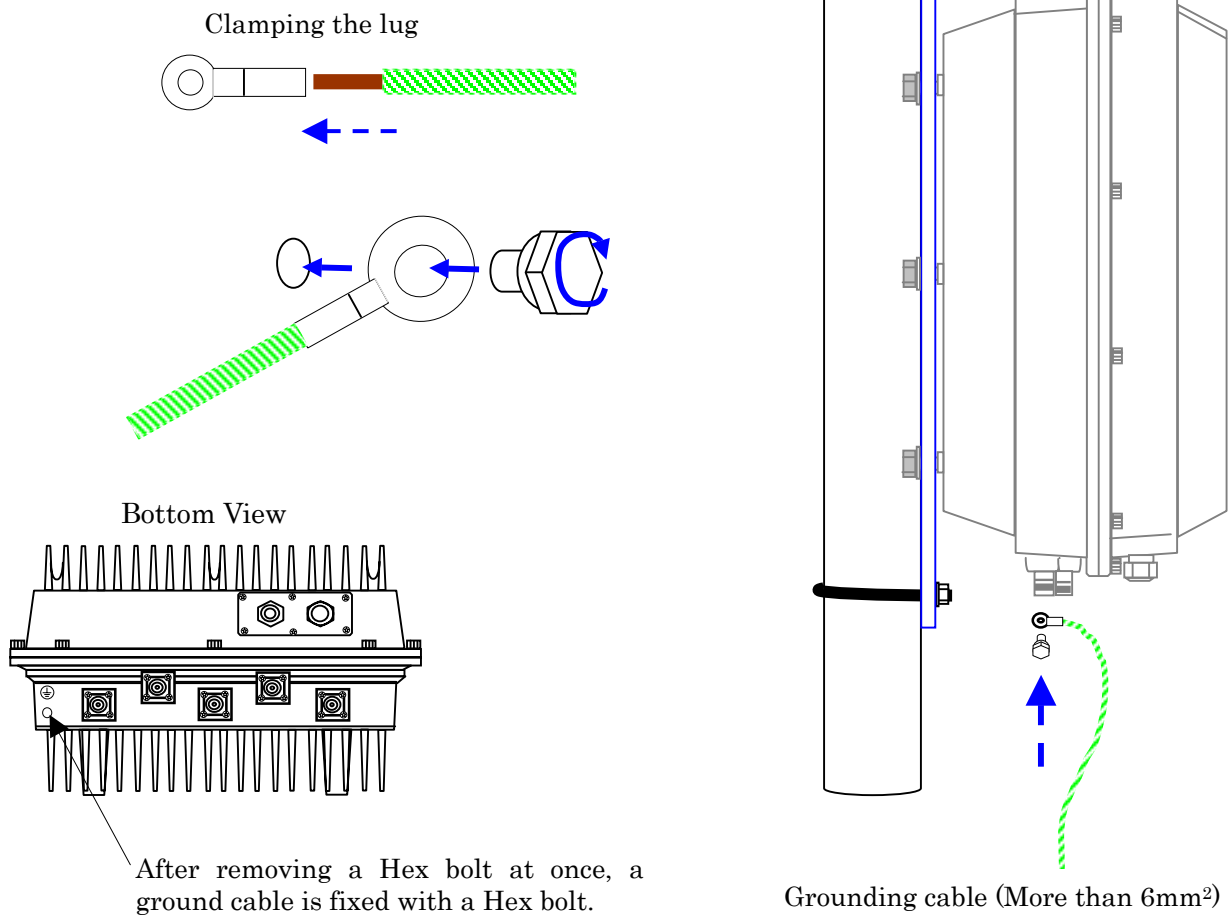

After removing a Hex bolt at once, a ground cable is fixed with a Hex bolt.

3.2.3.3 Connecting the PA control cable

1) Removing the cable clamp for the PA control cable

Remove the cable clamp fixing screw with a “+” screwdriver and remove the cable clamp.

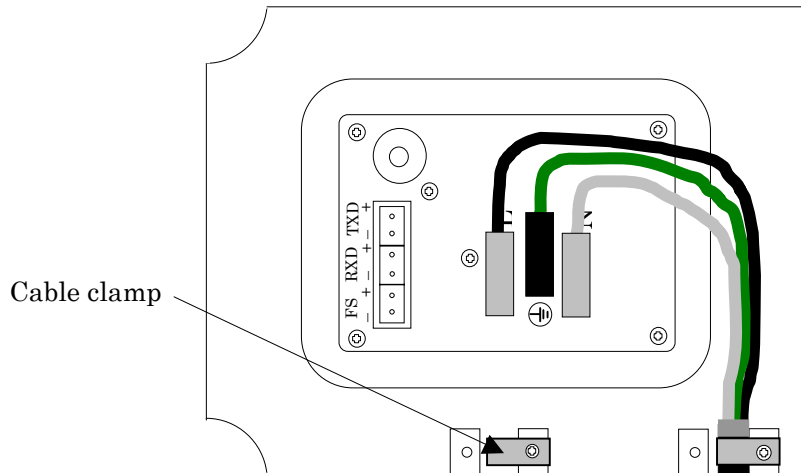

2) Removing the dome nut for the PA control cable

Remove the dome nut for the PA control cable at the bottom of the PA Unit and remove the cable packing.

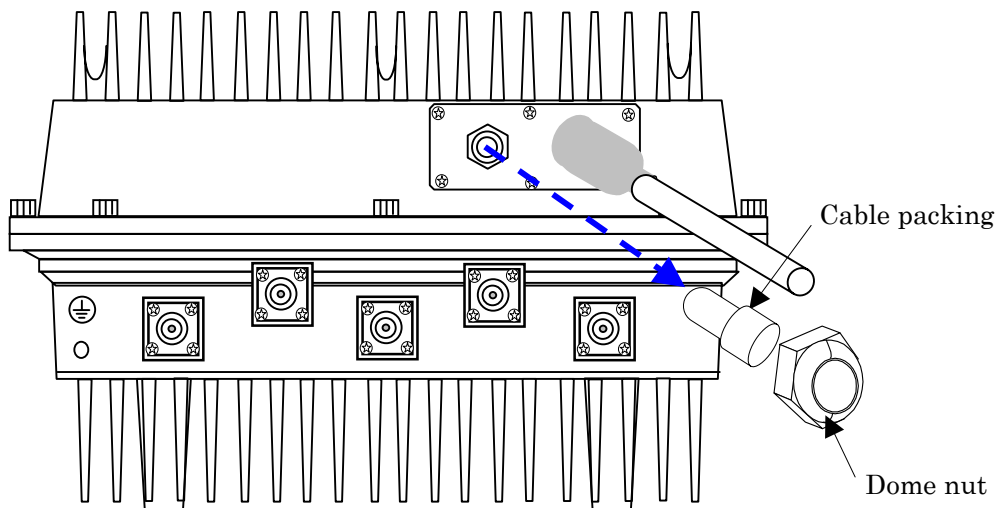

- 3) Pre-finishing the PA control cable
Put the PA control cable through the cold shrinkable tube, the dome nut and the cable packing in this order.
(See the following figure for the direction.)

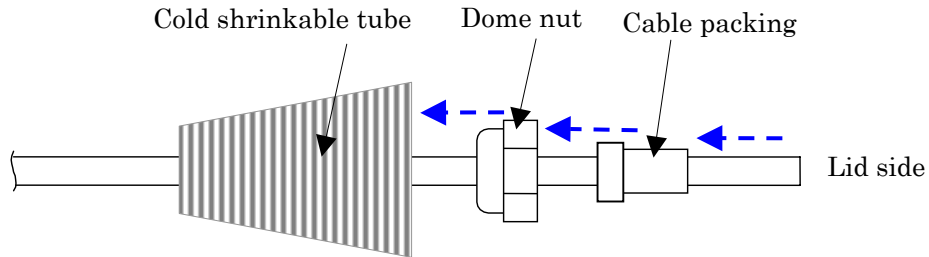

Peel the sheath off the PA control cable to expose the conductor.
→Peeling length of the sheath: 10 to 15 cm

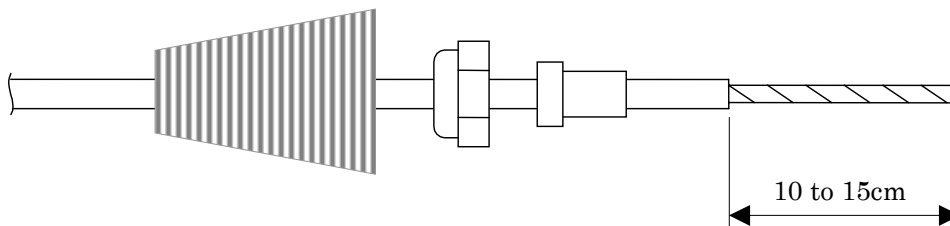

Loosen the copper shield and coil it around the conductor at the shield root part by more than 4 turns.
For PA control cable, 3 pairs of twisted-pair cables are used.
If there are 4 pairs of cables, coil the cable with a tape to prevent the extra one pair from short circuit.

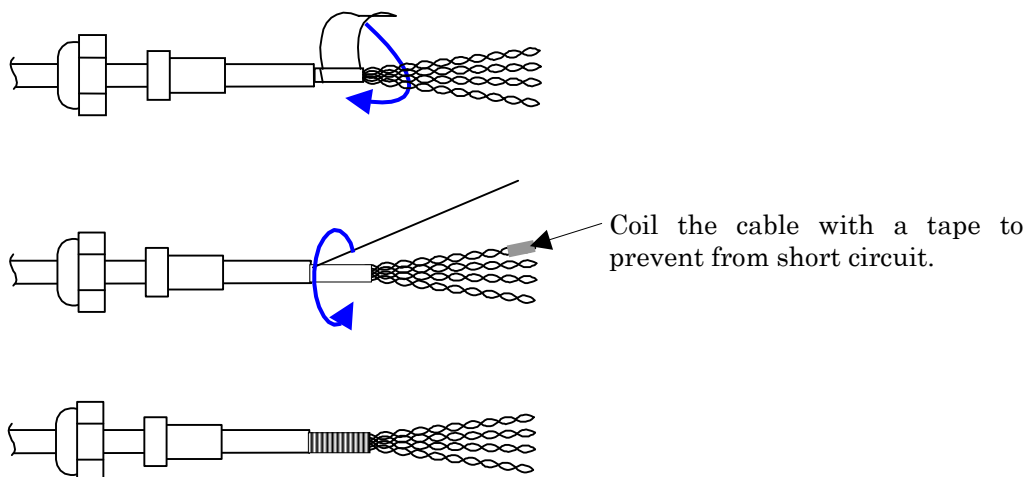

- 4) Inserting the PA control cable
 While bending the PA control cable along the direction of the Lid interior beforehand, insert it into the Lid inside.

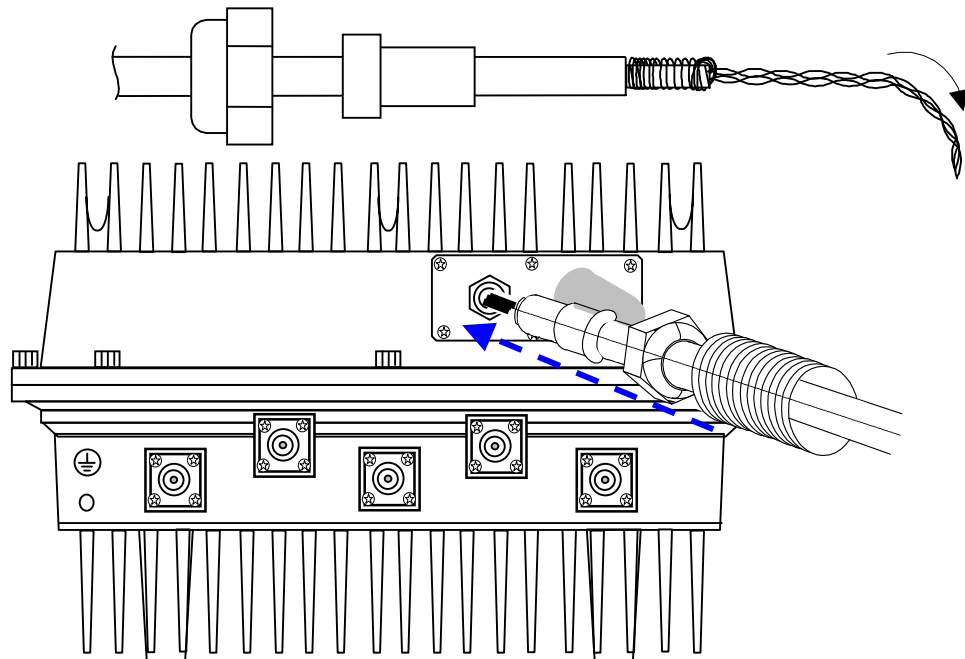

- 5) Unstitch the conductor (3 pairs = 6 conductors) and connect them to the specified crimping connector.

For the assignment of inserting conductor 1pin and 2pin to the connector, refer to the following figure.

Press the connector while inserting the conductors to the far end.

Recommended connector: Press-contact connector manufactured by DDK (DDK Ltd.)
 Product No: 232D-02S1B-DA2

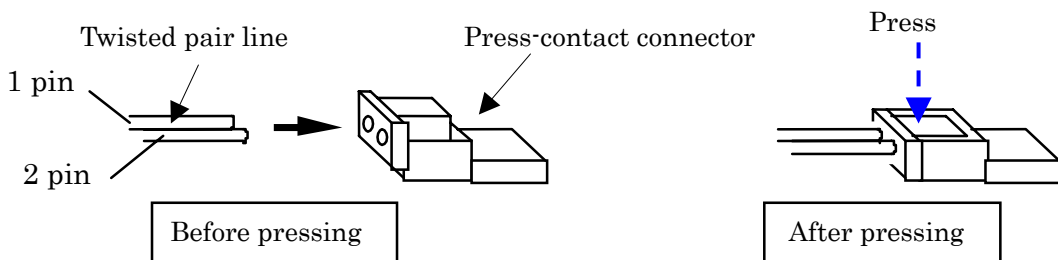

TXD+	2 pin	Green
TXD-	1 pin	Green/spiral
RXD+	2 pin	Orange
RXD-	1 pin	Orange/spiral
FS+	2 pin	Blue
FS-	1 pin	Blue/spiral

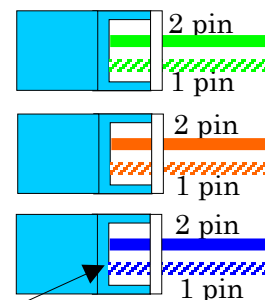

Press connector while the conductors are inserted to the far end.

6) Fixing the cable clamp

Position the copper shield part of the cable at the arrow marking in the following figure and fix it with the cable clamp and fixing screw (M4).

→Tightening torque: 1.5N·m

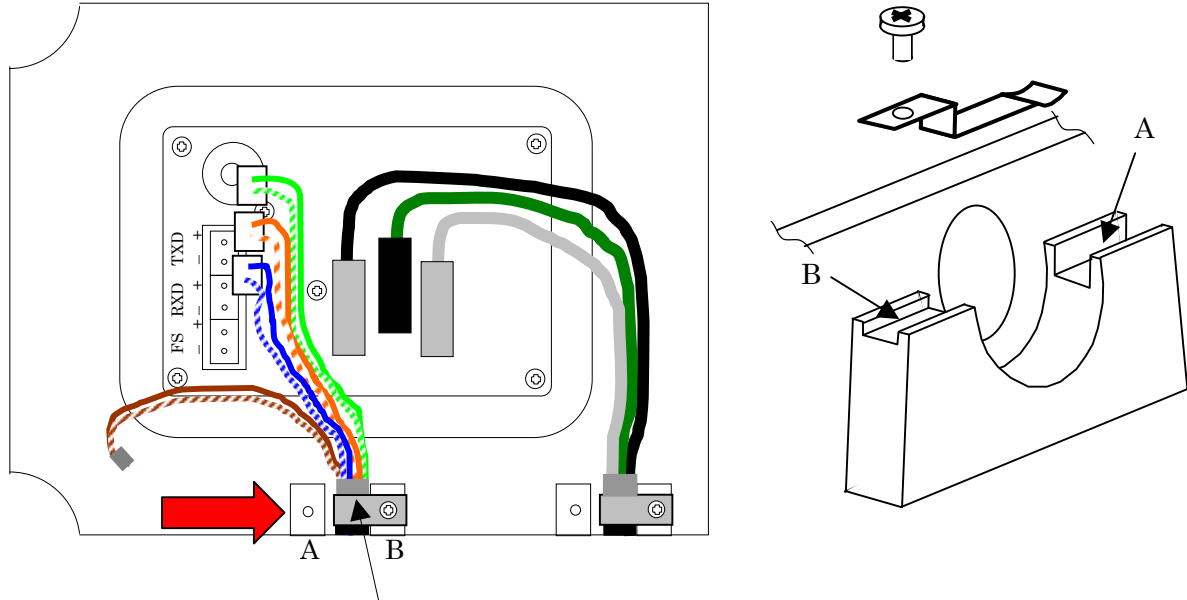

Fix the cable clamp with a fixing screw (M4).

The attachment position of a cable clamp changes by the diameter of a cable.

When the diameter of a cable is from 6 to 8mm, it attaches at A-side.

When the diameter of a cable is from 7 to 10.5mm, it attaches at B-side.

Note)

If fixing of the shield is incomplete, noise may be caused during communication or interference may be caused on other electronic devices.

7) Tightening the dome nut

After inserting the cable packing, tighten the dome nut by hand and then retighten it using a torque wrench.

→Tightening torque: 2.45N·m

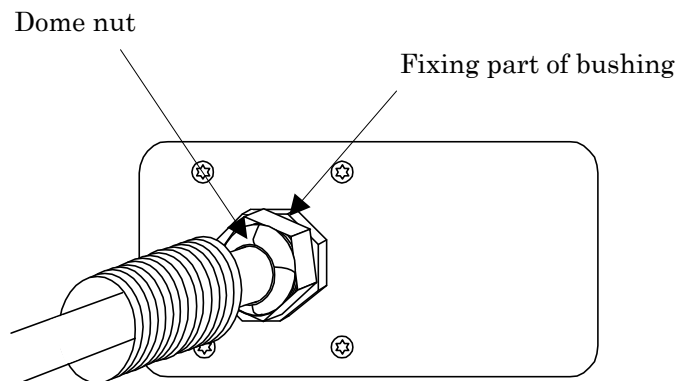

- 8) Inserting the press-contact connector
Insert the press-contacted connector to the (232D) connector for the PA control in the Lid.

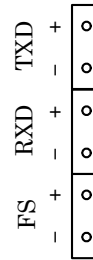
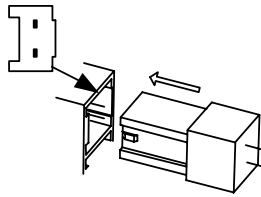

- 9) Treatment of the PA control cable
Form the AC power supply cable along the inside of the Lid so that the Lid does not clip the cable.

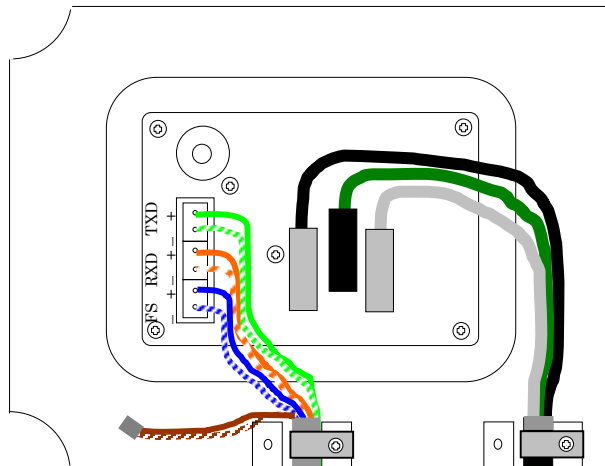

- 10) Waterproof treatment for the PA control cable
Cover the cold shrinkable tube over the root of the connector and shrink it.

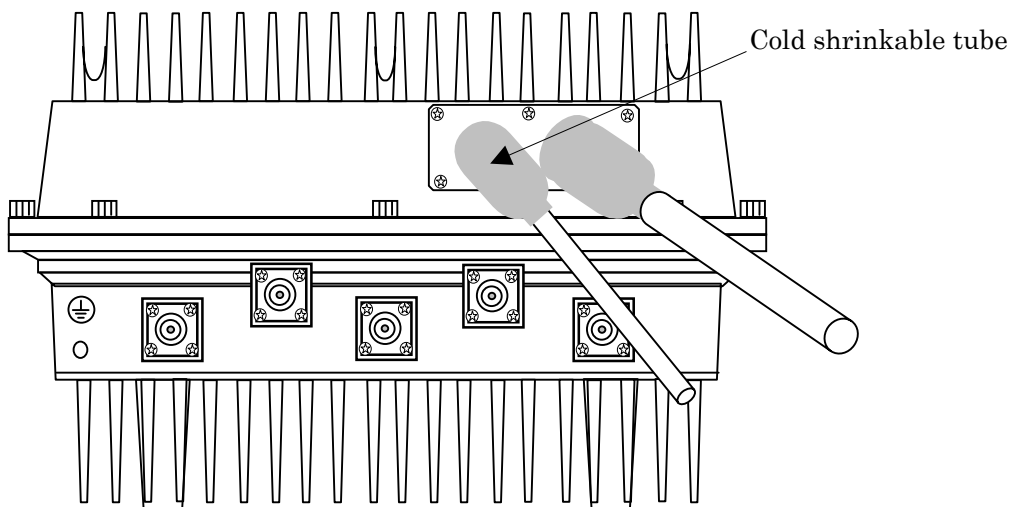

3.2.3.4 Connecting the antenna cable

- 1) Pre-finishing the antenna cable
Put antenna cable through cold shrinkable tube.
(See the following figure for the direction.)

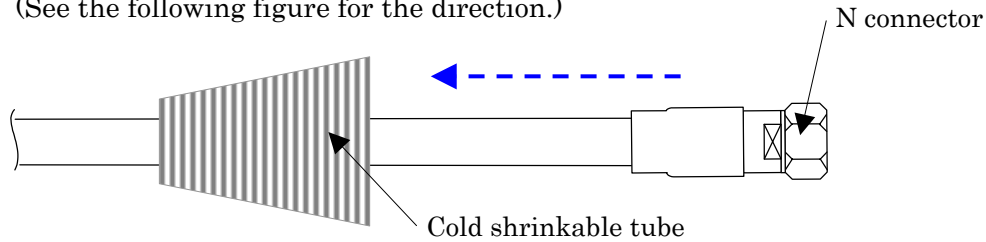

- 2) Removing the antenna connector dustproof cap
Remove the dustproof cap attached to the antenna connector of the PA unit.

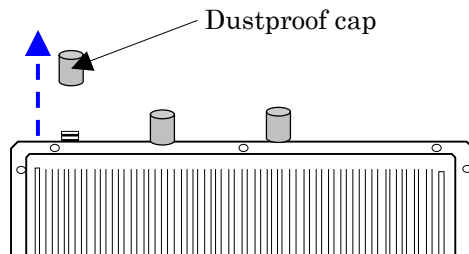

- 3) Connecting the antenna cable to PA unit
Mate each antenna cable with the antenna connector of the PA unit and fasten them by hand, and then tighten them with the torque specified for the connector by using a torque wrench.
→Tightening torque: 20 to 25N·m

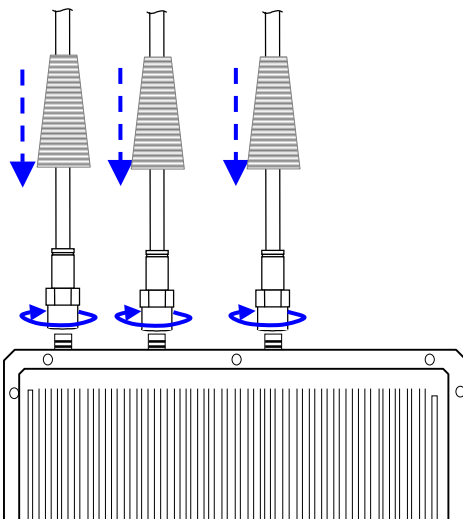

(Note)

Insert the connector straightforward. Excessive force to the connector may cause connector broken.

- 4) Waterproof treatment for the antenna cable connector
Cover the cold shrinkable tube over the root of the connector and shrink it.

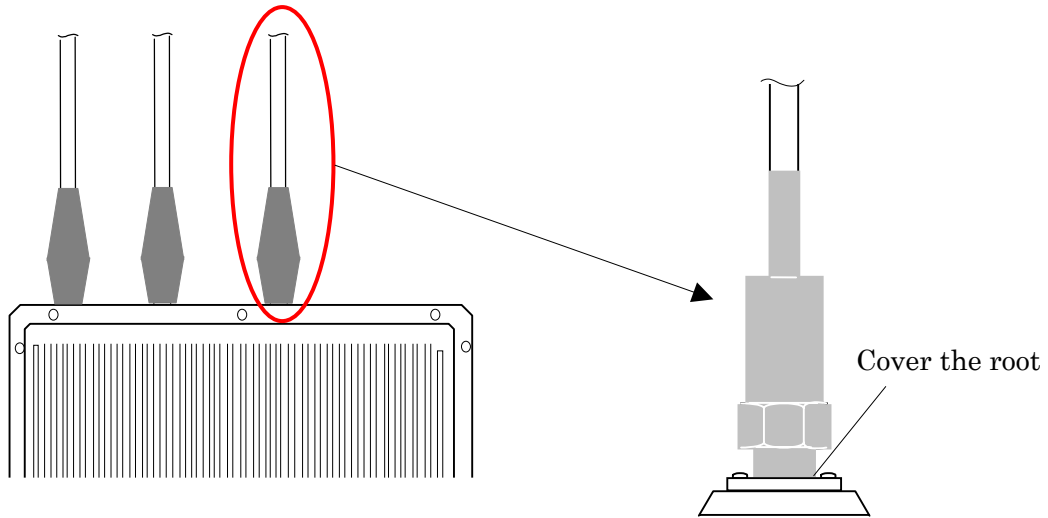

- 5) Forming the antenna cable
After all the cables have been connected, form the cable so that no permanent load is applied to the junction of the antenna connector, the surge arrester and the antenna cable.
In addition, fix cables between antenna and PA unit to the structure at some portions with fixing bands so as not to prevent cables from drooping or swinging.

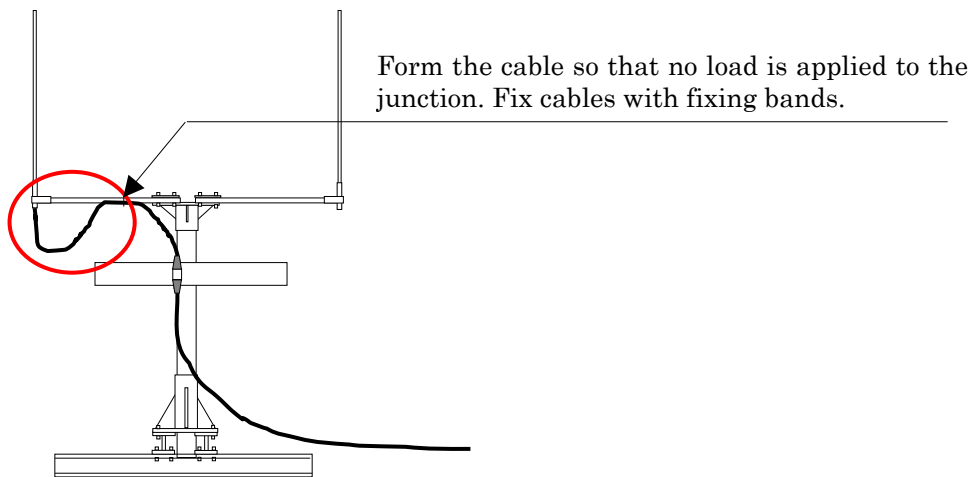

3.2.3.5 Connecting the Calibration cable

There are two methods in connecting the Calibration cable.

3.2.3.5.1 Star connection

Refer to figure of 2.1.3.2.1

1) Connecting to the PA Unit 1

Remove the dustproof caps attached to CAL IN and CAL ONT of the PA Unit 1.

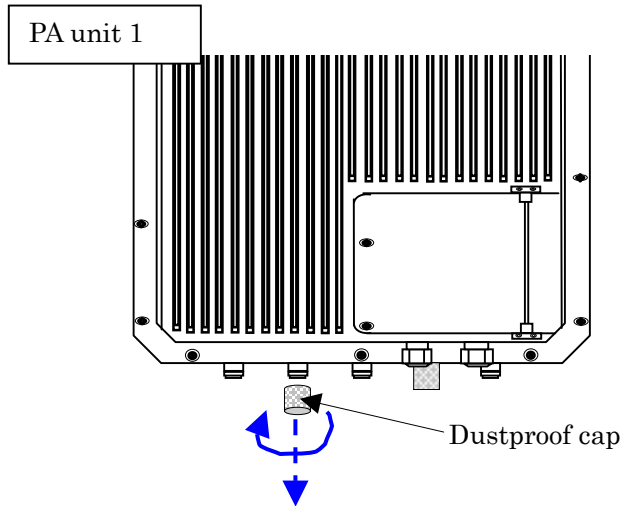

2) Pre-finishing the Calibration cable (CAL IN)

Put the Calibration cable through the cold shrinkable tube.
(See the following figure for the direction.)

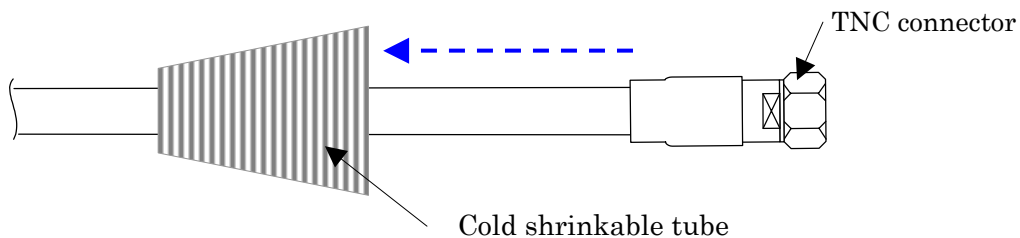

3) Connecting to CAL IN

Connect the Calibration cable to the connector of CAL IN on the PA Unit 1 with the specified torque.

→Tightening torque: 0.45 to 0.69N·m

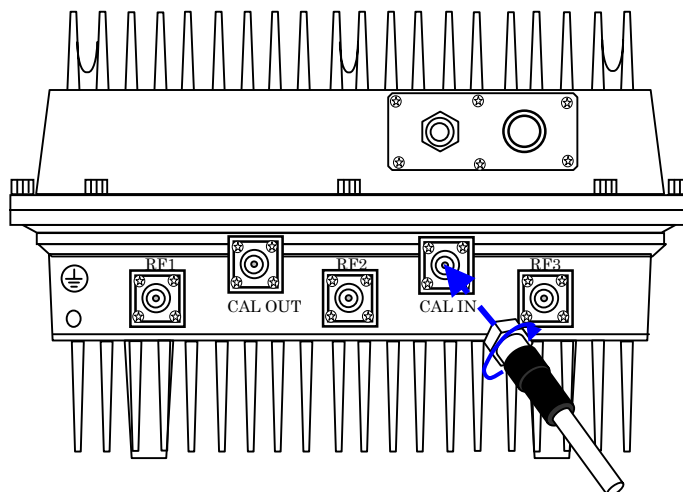

- 4) Waterproof treatment of the Calibration cable (CAL IN)
Cover the cold shrinkable tube over the root of the connector and shrink it.

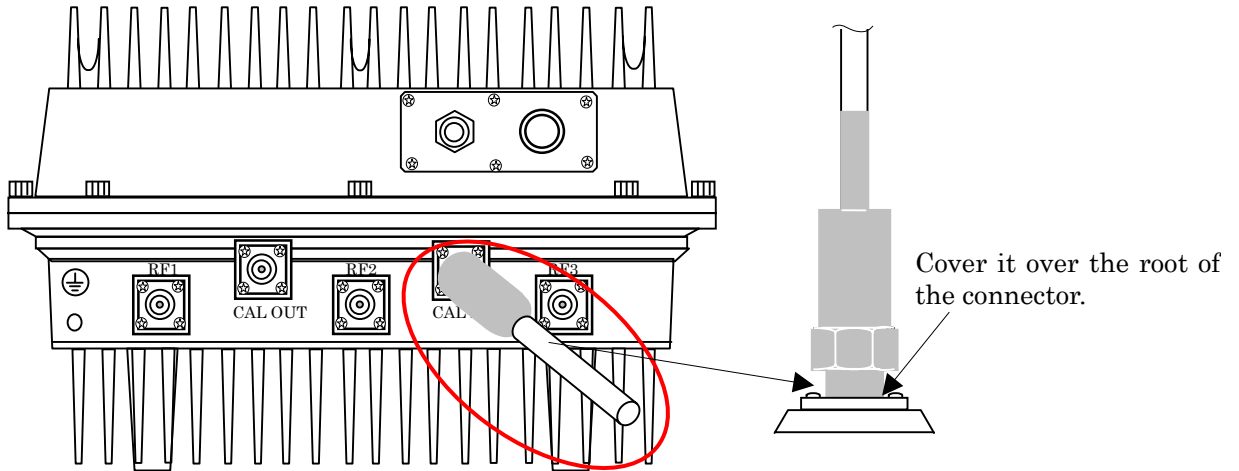

- 5) Mounting the terminator
Mount the terminator to CAL OUT of the PA Unit 1.
→Tightening torque: 0.45 to 0.69N·m

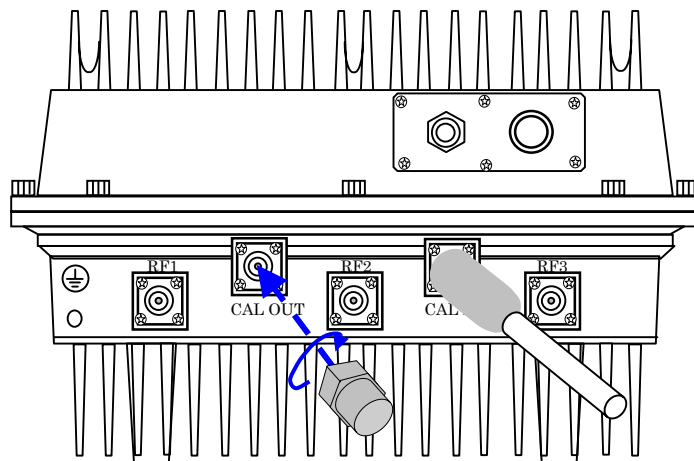

- 6) Waterproof treatment of the terminator
Wind a self-fusing rubber tape and then a vinyl tape around the terminator.

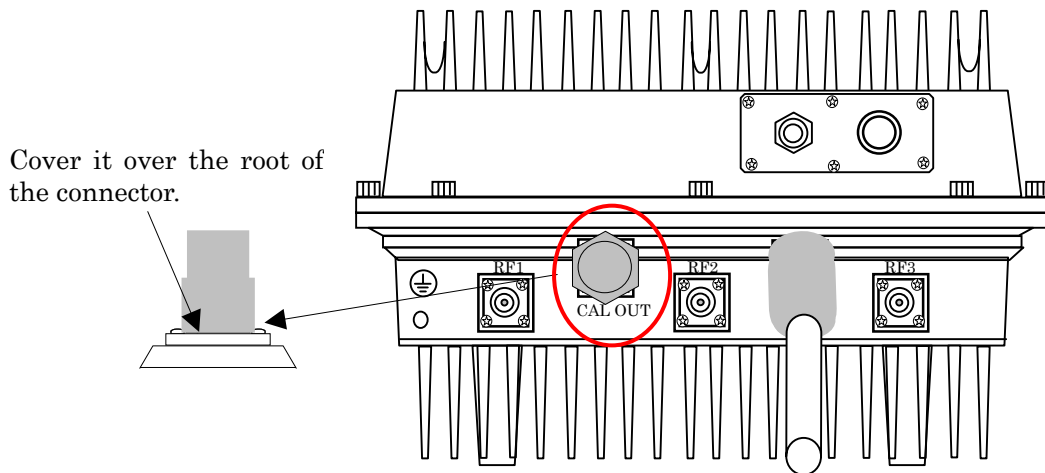

- 7) Connecting to PA Unit 2, PA Unit 3 and PA Unit 4
Connect to PA Unit 2, 3 and 4 as same sequence as of PA Unit 1.
- 8) Routing the Calibration cable
Lead the Calibration cable from CAL IN of the PA Unit 1, 2,3 and 4 to the location of the Base Unit determined by the site survey.

3.2.3.5.2 Daisy-chain connection

Refer to figure of 2.1.3.2.2

- 1) Connecting to the PA unit 1
Remove the dustproof cap attached to the CAL IN and CAL ONT of the PA Unit 1.

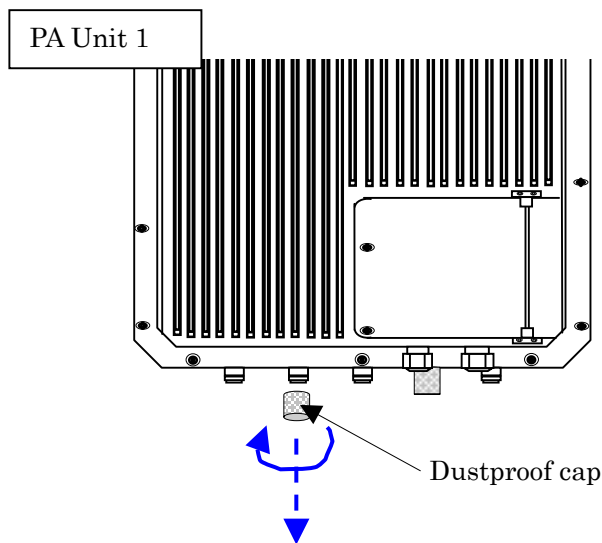

- 2) Pre-finishing the Calibration cable (CAL IN)
Put the Calibration cable through the cold shrinkable tube.
(See the following figure for the direction.)

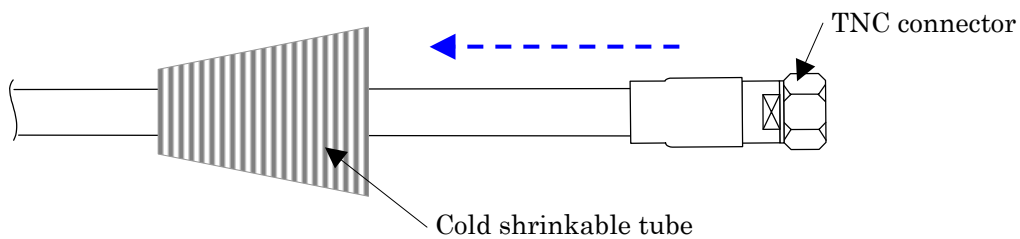

- 3) Connecting to CAL IN
Connect the Calibration cable to the connector of CAL IN on the PA Unit 1 with the specified torque.
→Tightening torque: 0.45 to 0.69N·m

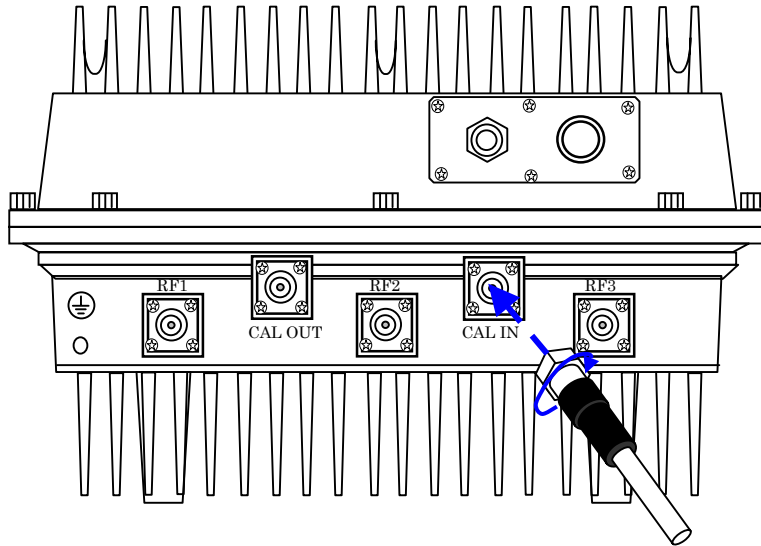

- 4) Waterproof treatment of the Calibration cable (CAL IN)
Cover the cold shrinkable tube over the root of the connector and shrink it.

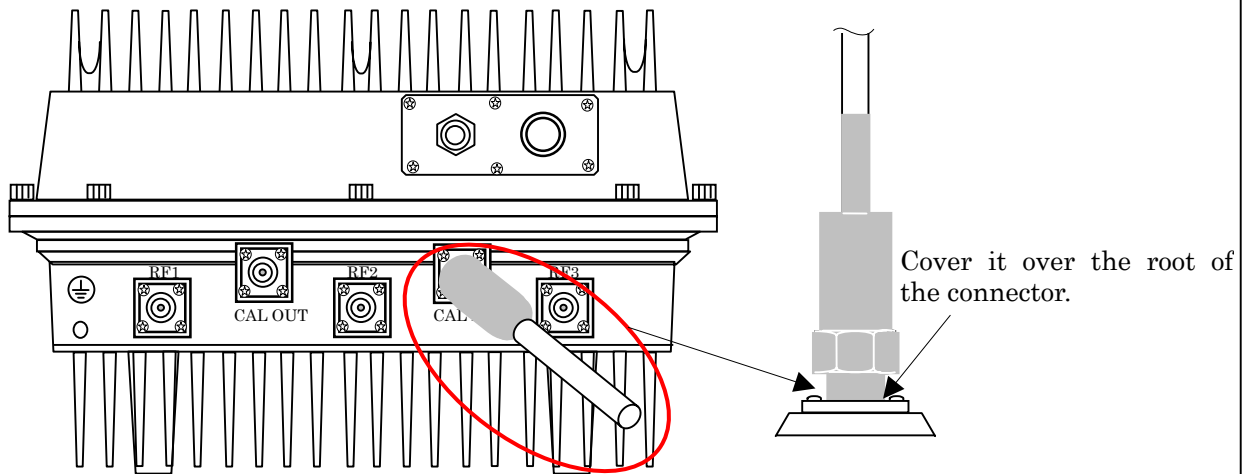

- 5) Pre-finishing the Calibration cable (CAL OUT)
Put Calibration cable through the cold shrinkable tube.
(See the following figure for the direction.)

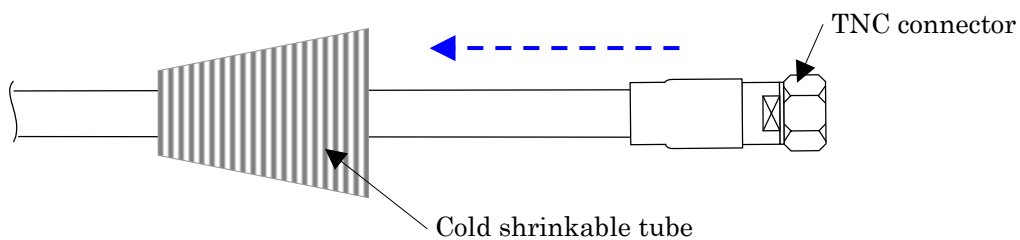

6) Connecting to CAL OUT

Connect the Calibration cable to the connector of CAL OUT on the PA Unit 1 with the specified torque.

→Tightening torque: 0.45 to 0.69N·m

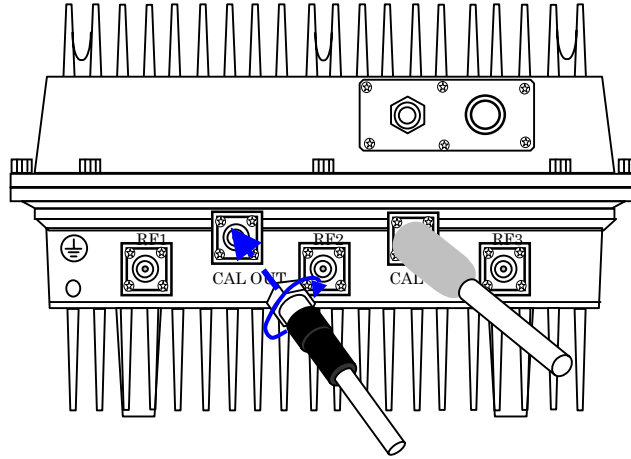

7) Waterproof treatment of the Calibration cable (CAL OUT)

Cover the cold shrinkable tube over the root of the connector and shrink it.

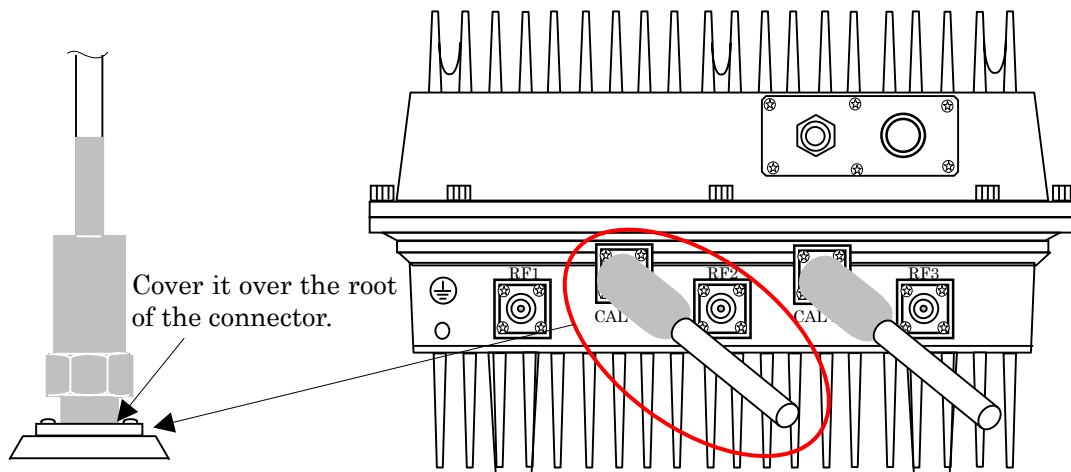

8) Connecting to the PA Unit 2

Remove the dustproof caps attached to the CAL IN and CAL OUT of the PA Unit 2.

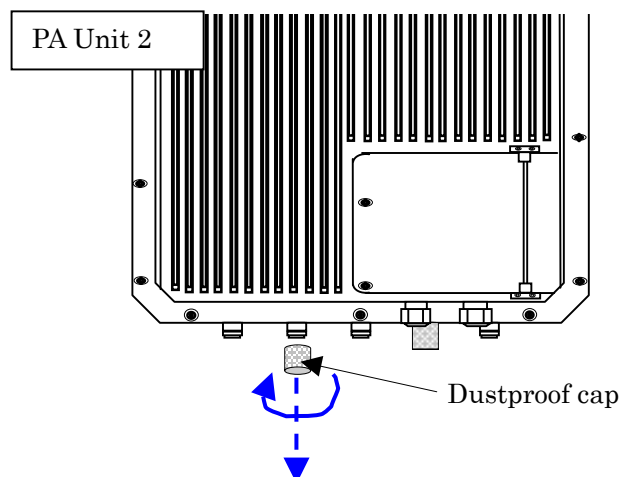

- 9) Pre-finishing the Calibration cable (CAL OUT cable from the PA unit 1)
Put the Calibration cable from CAL OUT on the PA Unit 1 through the cold shrinkable tube.
(See the following figure for the direction.)

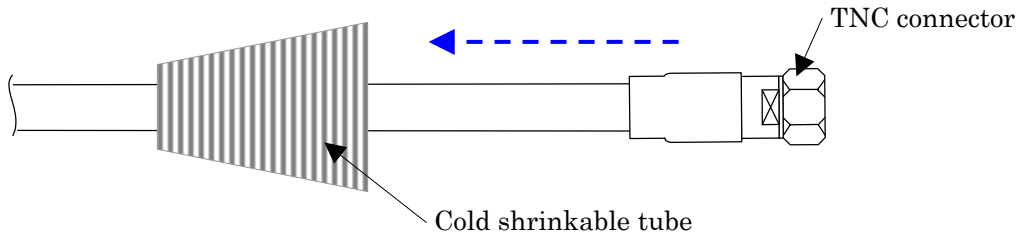

- 10) Connecting the Calibration cable
Connect the Calibration cable to the connector of CAL IN on the PA Unit 2 with the specified torque.
→Tightening torque: 0.45 to 0.69N·m

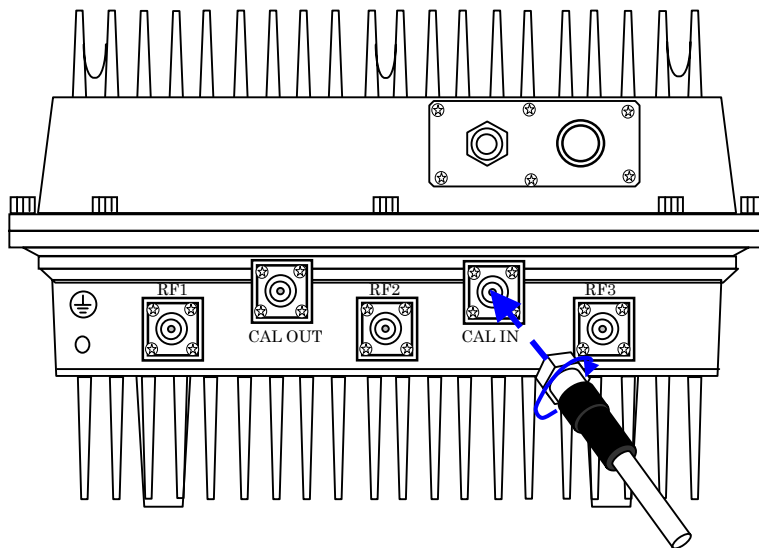

- 11) Waterproof treatment of the Calibration cable (CAL IN)
Cover the cold shrinkable tube over the root of the connector and shrink it.

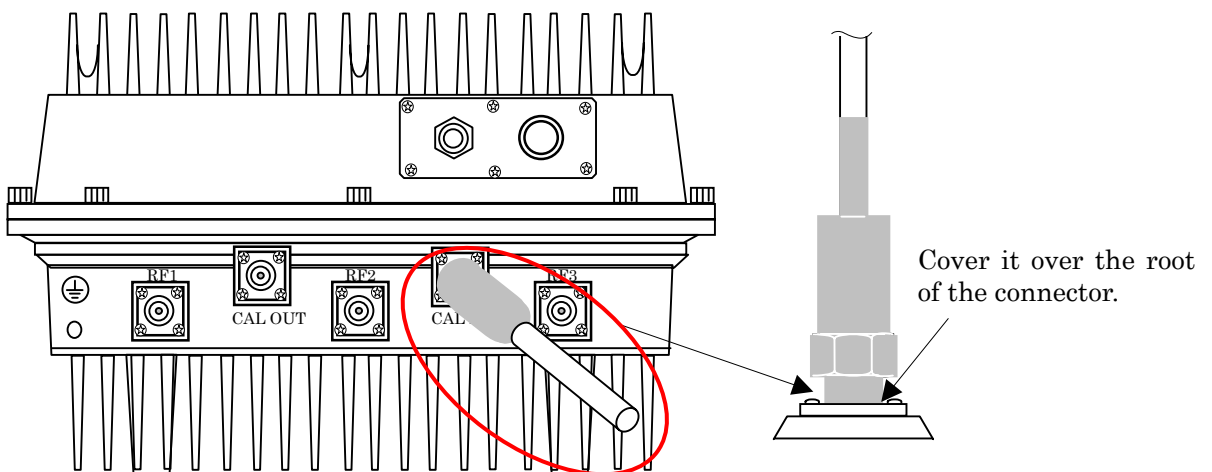

12) Mounting the terminator

Mount the terminator to CAL OUT of the PA Unit 2.

→Tightening torque: 0.45 to 0.69N·m

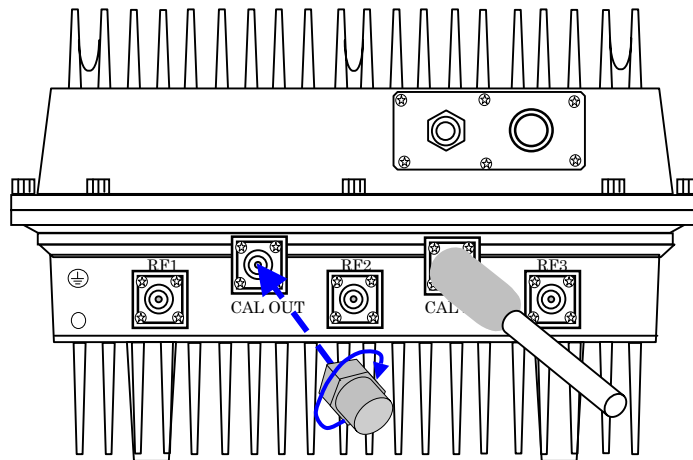

13) Waterproof treatment of the terminator

Wind a self-fusing rubber tape and then a vinyl tape around the terminator.

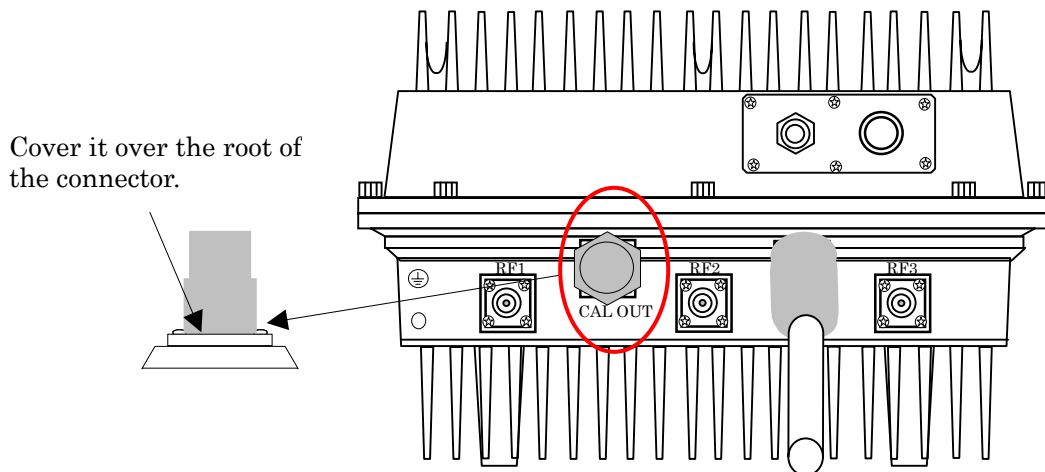

14) Connecting to the PA unit 3, the PA unit 4

Connect to the PA Unit 3 as same sequence as of the PA Unit 1, and connect the PA Unit 4 as same sequence as of the PA Unit 2.

15) Routing the Calibration cable

Lead the Calibration cable from CAL IN of the PA Unit 1 and the PA Unit 3 to the location of the Base Unit determined by the site survey.

3.2.3.6 Connecting the PU-BU RF cable

Connect the PU-BU RF cable to the PA Units, from the PA Unit 1 to the PA unit 4, in order.

1) Pre-finishing the PU-BU RF cable

Put PU-BU RF cable through cold shrinkable tube.
(See the following figure for the direction.)

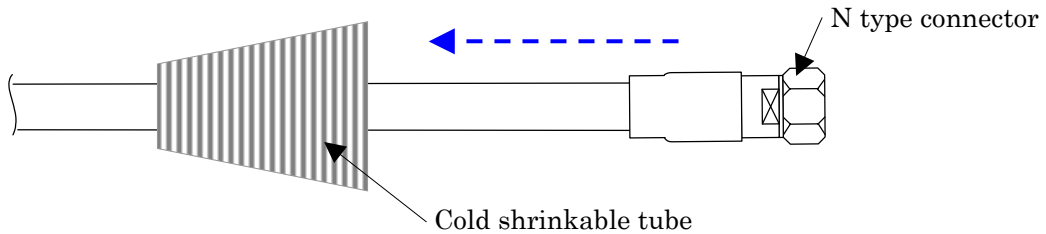

2) Connecting the PU-BU RF cable

Connect the PU-BU RF cable to the connector of the RF 1 on PA Unit 1 with the specified torque.

→Tightening torque: 1.96 to 2.94N·m

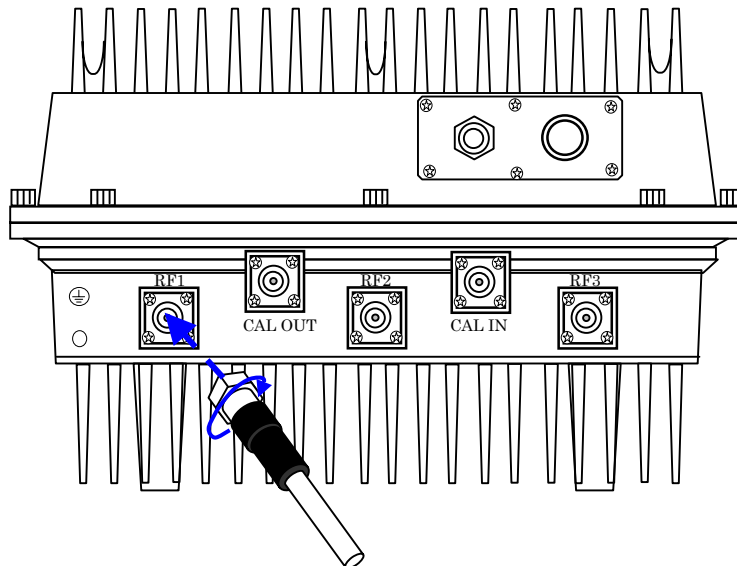

3) Waterproof treatment of the PU-BU RF cable

Cover the cold shrinkable tube over the root of the connector and shrink it.

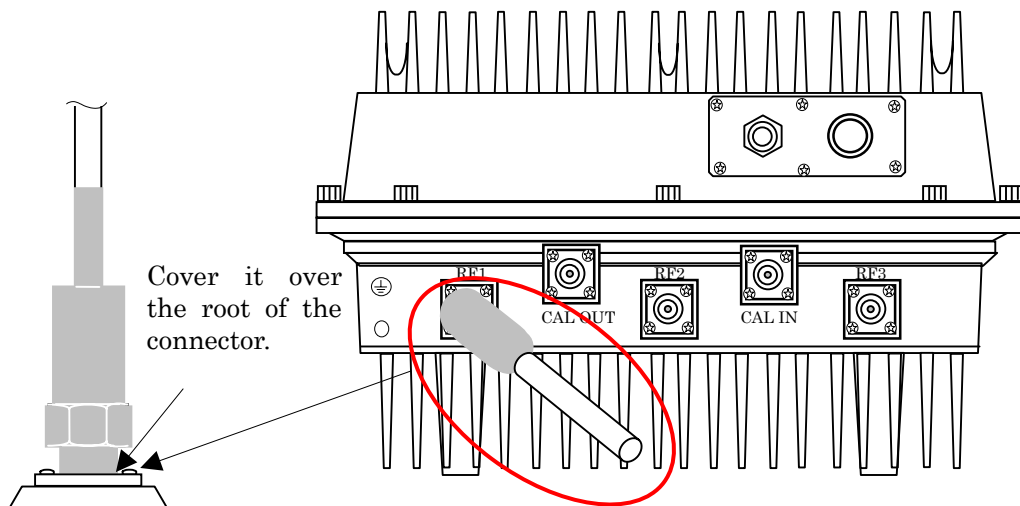

- 4) Pre-finishing the PU-BU RF cable
Put the PU-BU RF cable through the cold shrinkable tube.
(See the following figure for the direction.)

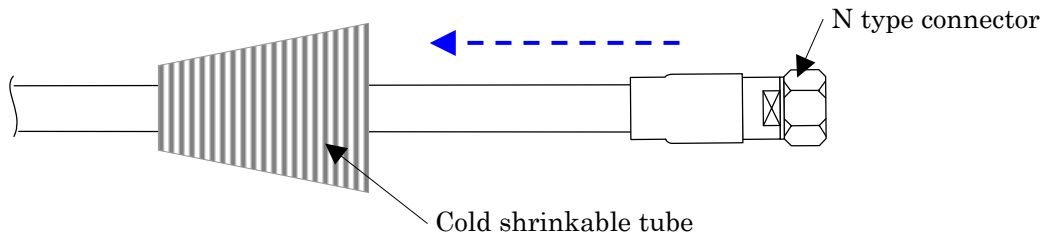

- 5) Connecting the PU-BU RF cable
Connect the PU-BU RF cable to the connector of RF 2 on the PA Unit 1 with the specified torque.
→Tightening torque: 1.96 to 2.94N·m

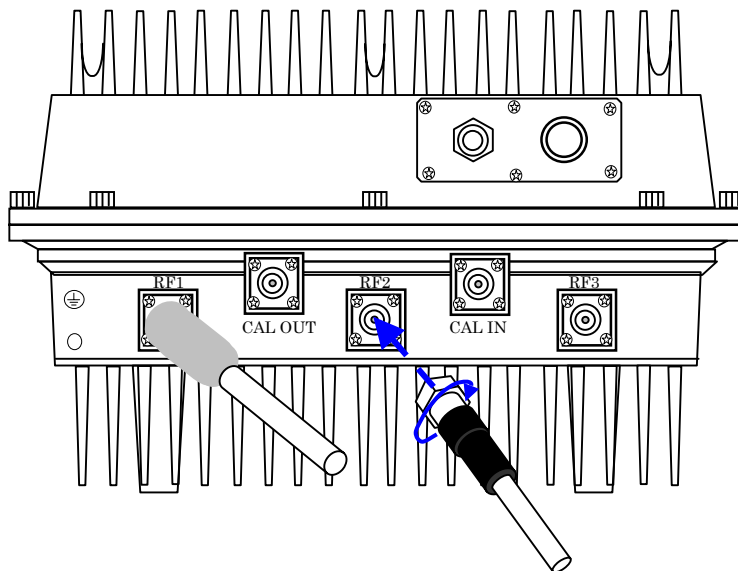

- 6) Waterproof treatment of the PU-BU RF cable
Cover the cold shrinkable tube over the root of the connector and shrink it.

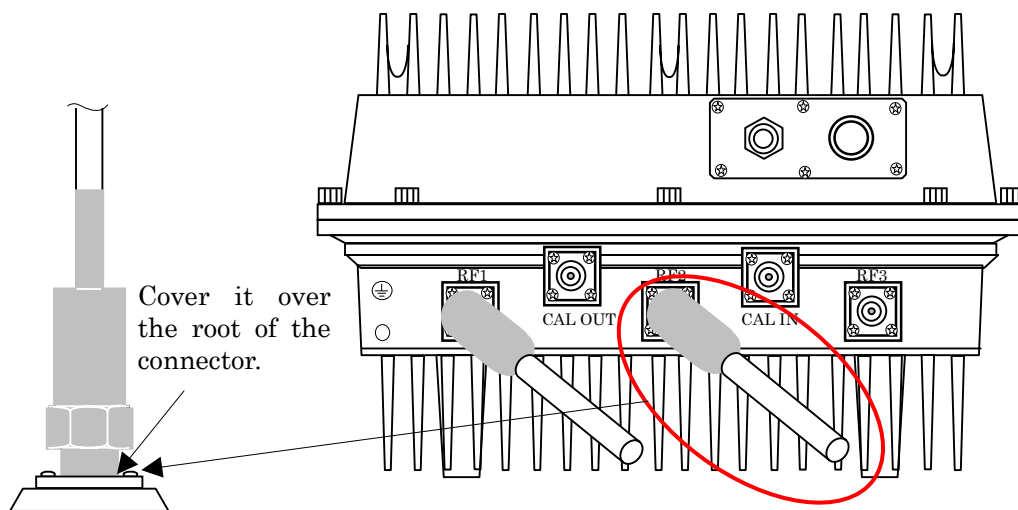

- 7) Pre-finishing the PU-BU RF cable
Put the PU-BU RF cable through the cold shrinkable tube.
(See the following figure for the direction.)

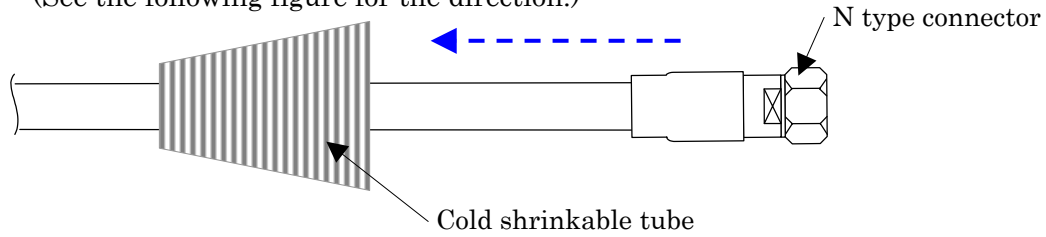

- 8) Connecting the PU-BU RF cable
Connect the PU-BU RF cable to the connector of RF 3 on the PA Unit 1 with the specified torque.
→Tightening torque: 1.96 to 2.94N·m

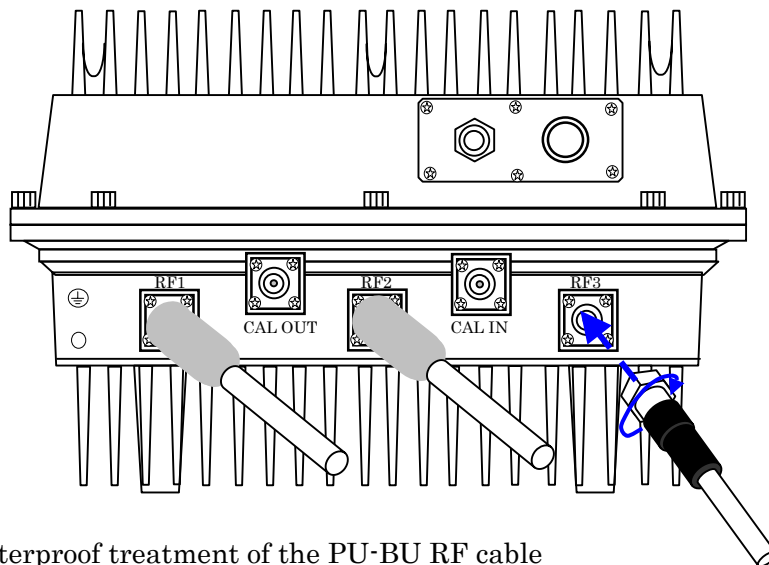

- 9) Waterproof treatment of the PU-BU RF cable
Cover the cold shrinkable tube over the root of the connector and shrink it.

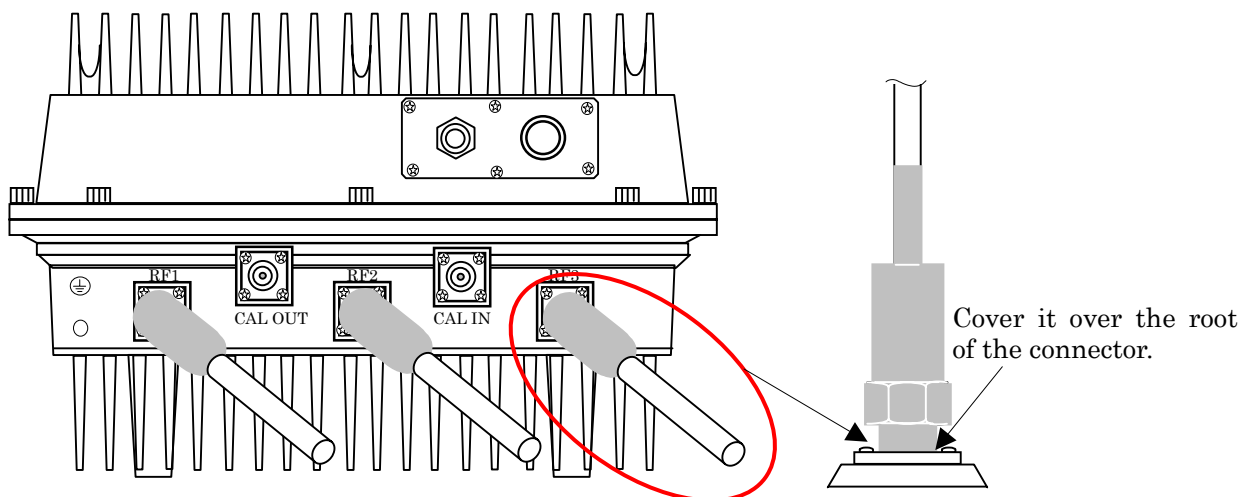

- 10) Connecting to the PA Unit 2, the PA Unit 3 and the PA Unit 4
Connect to the PA Unit 2, 3 and 4 as same sequence as of the PA Unit 1.

- 11) Routing the PU-BU RF cable
Lead the PU-BU RF cable from RF 1 to RF 3 on each PA Unit, PA Unit 1, 2, 3 and 4 to the location of the Base Unit determined by the site survey.

3.3 Installing the GPS Unit

As for MMP connector assembling, refer to the manual “Assembly instructions by DEUTSCH ECD”.

- 1) Put the GPS cable through the mount adaptor

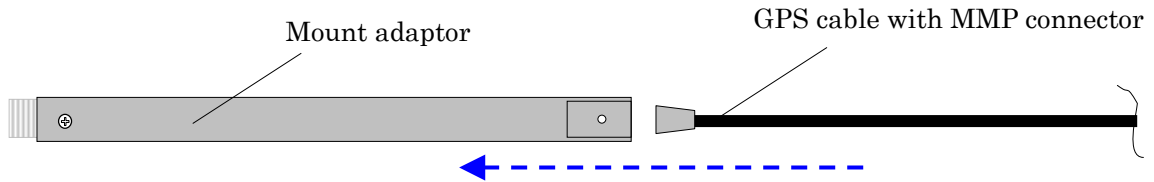

- 2) Put the GPS cable through the cold shrinkable tube

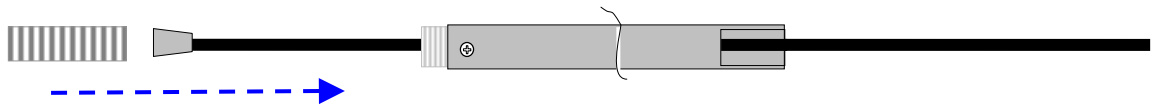

- 3) Connect the GPS Unit cable connector and the GPS cable connector

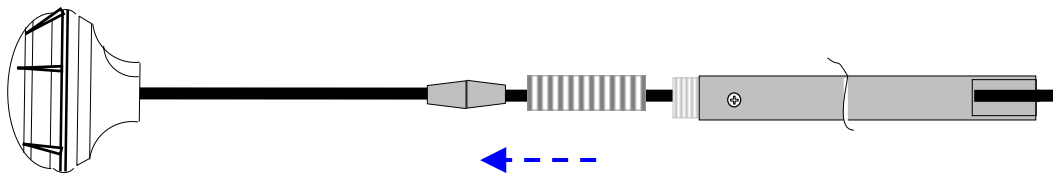

- 4) Cover the connector with the cold shrinkable tube and then shrink it
The cold shrinkable tube is made smaller than the diameter of inner of the mount adaptor.

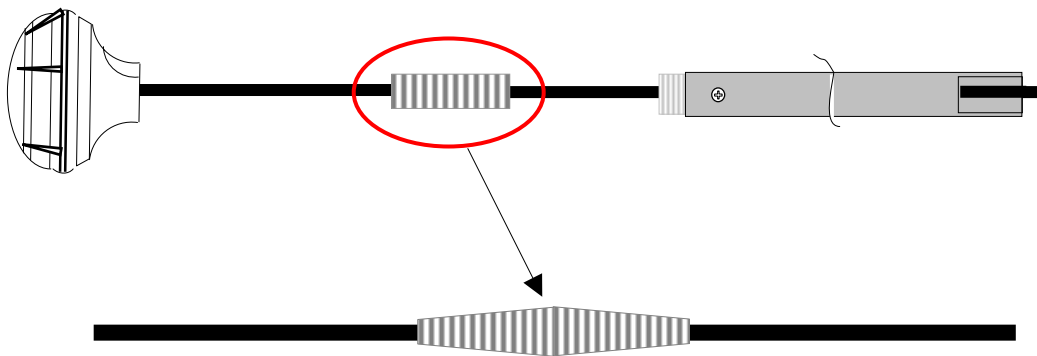

- 5) The length of the cable is measured

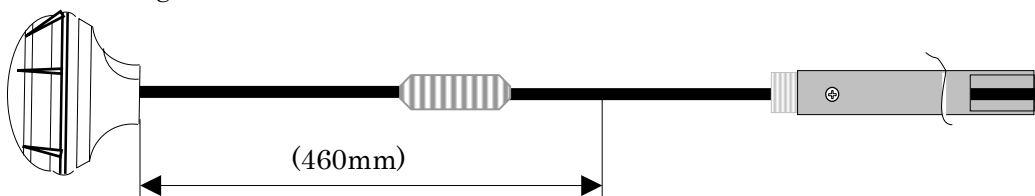

6) Peel the sheath off 30mm in width

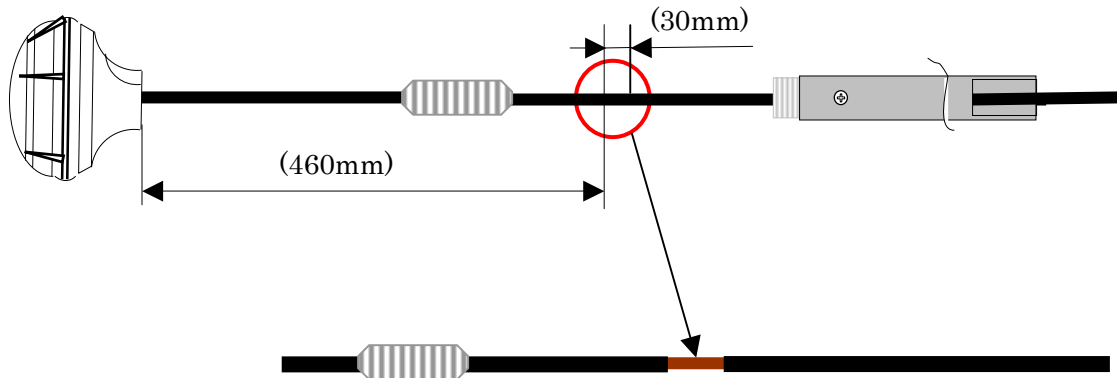

7) Screw the mount adaptor to the GPS Unit

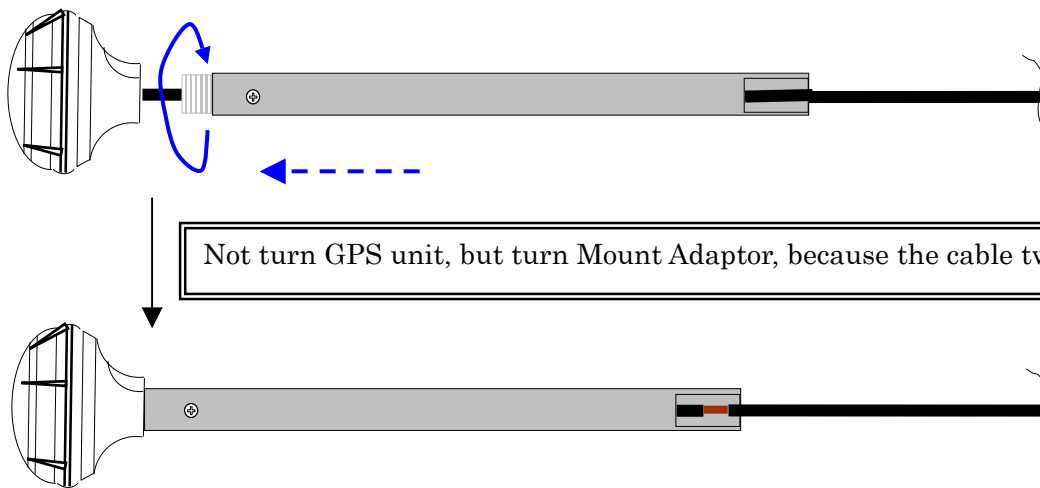

8) Place FG fixing plate on the outer conductor and tighten screw on the mount adaptor.
→Tightening torque: 0.88 to 1.08N·m

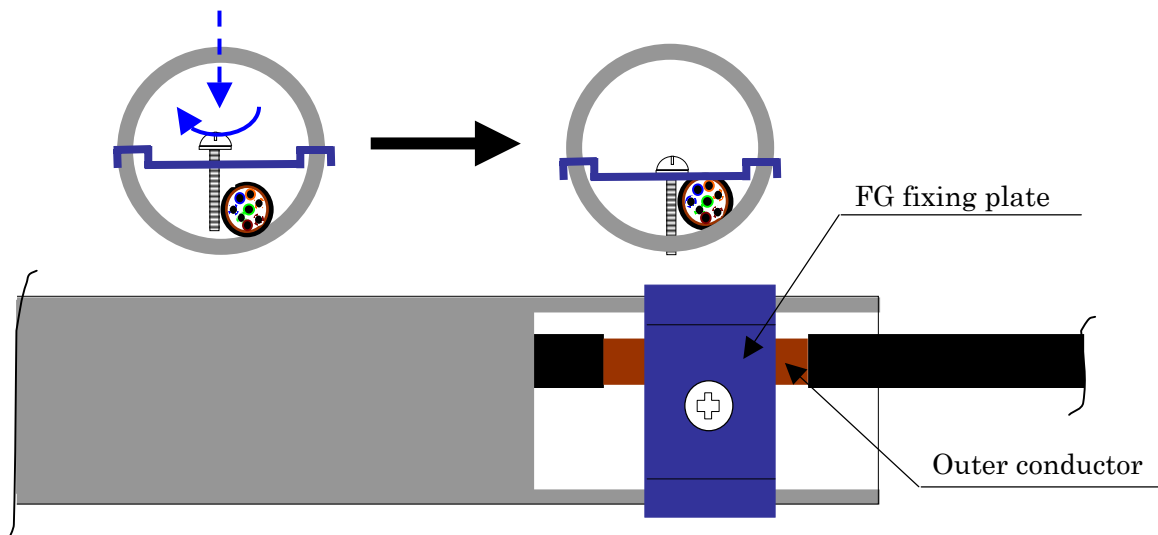

9) Waterproofing

Spread out silicone caulking material around the connection part of a GPS unit and a Mount adaptor one turn.

Waterproofing at the opening of a mount adaptor is carried out in the following procedure so that outer conductor and FG fixing plate may not corrode.

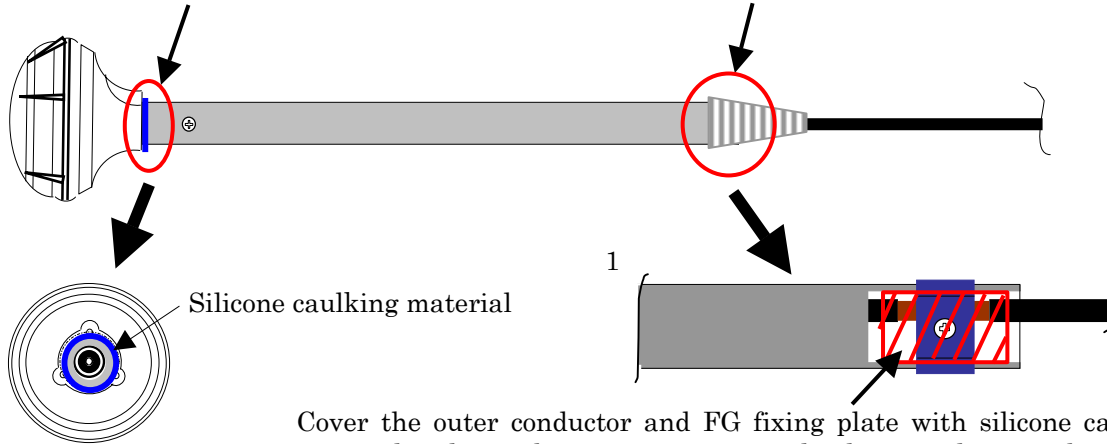

Cover the outer conductor and FG fixing plate with silicone caulking material and airtight processing is completely carried out so that no air penetrates into it.

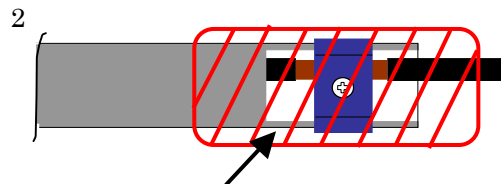

A butyl rubber tape and a vinyl tape or a butyl rubber tape and a cold shrinkable tube are wrapped, and waterproofing processing is carried out completely.

10) Mount adaptor is fixed

Temporarily fix the mount adaptor to the place determined by site survey.
At the same time, connect a grounding cable to the mount adaptor.

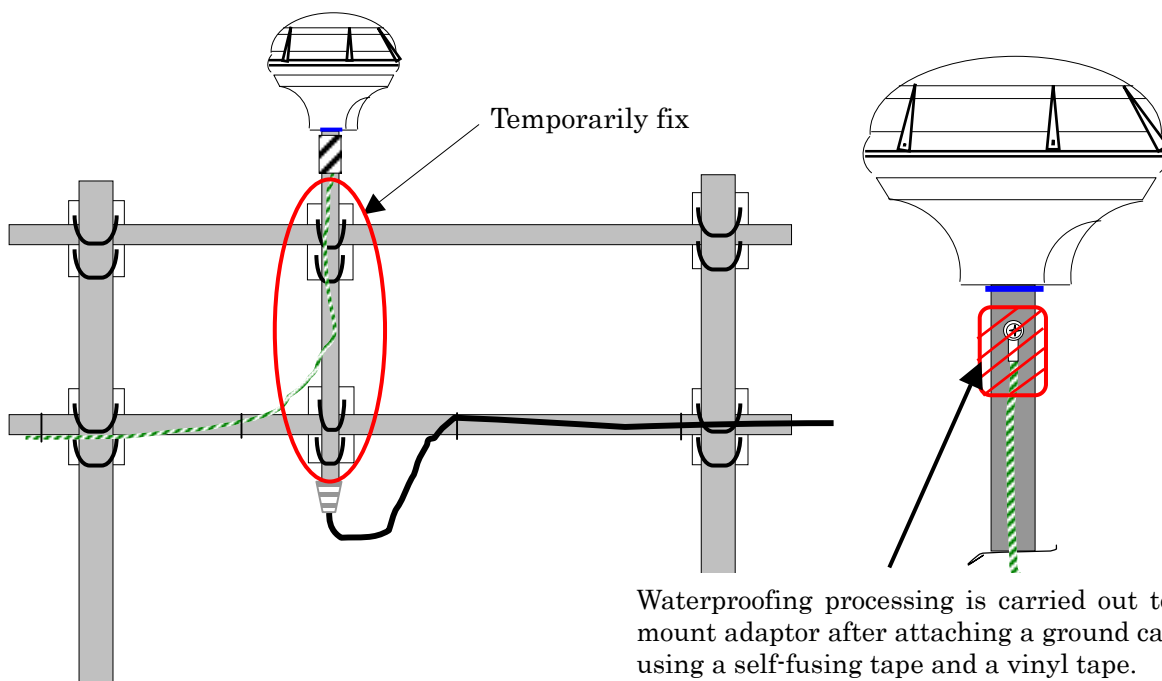

Waterproofing processing is carried out to a mount adaptor after attaching a ground cable using a self-fusing tape and a vinyl tape.

- 11) Adjust its perpendicularity to be within 4.5°.

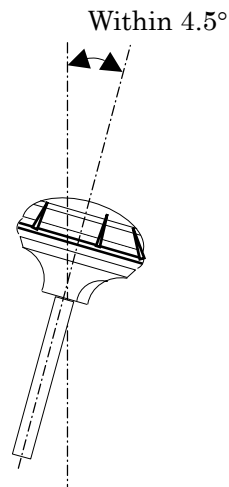

- 12) Firmly tighten the mount adaptor

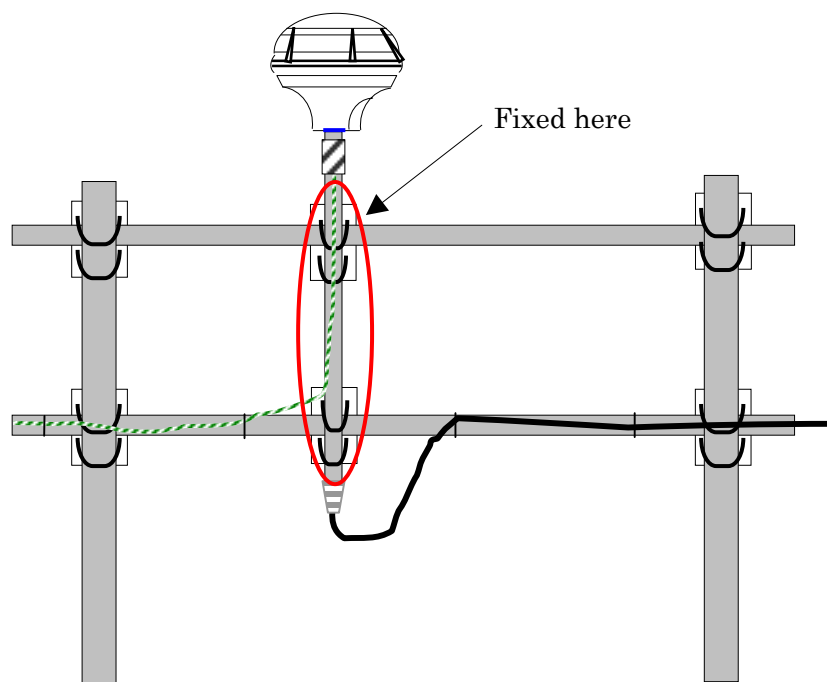

- 13) Routing the GPS cable

Lead the GPS cable to the location of the Base Unit determined by the site survey.

3.4 Installing the Base Unit

Install the Base Unit at the place determined by the site survey.

3.4.1 Mounting and removing the Eyebolt

1) Removing the top plate

Open the front door and remove 2 crosshead screws (M6) fixing the top plate with a crosshead screwdriver. (See the following figure.)

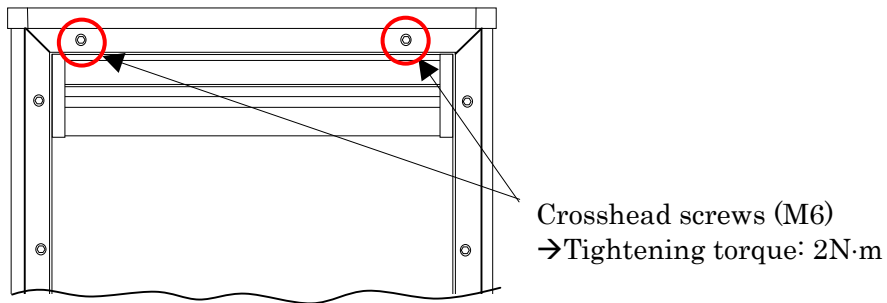

2) Slide the top plate toward front side and lift it. (note: bottom side of the top plate is connected with chassis of the Base Unit by a grounding cable.)

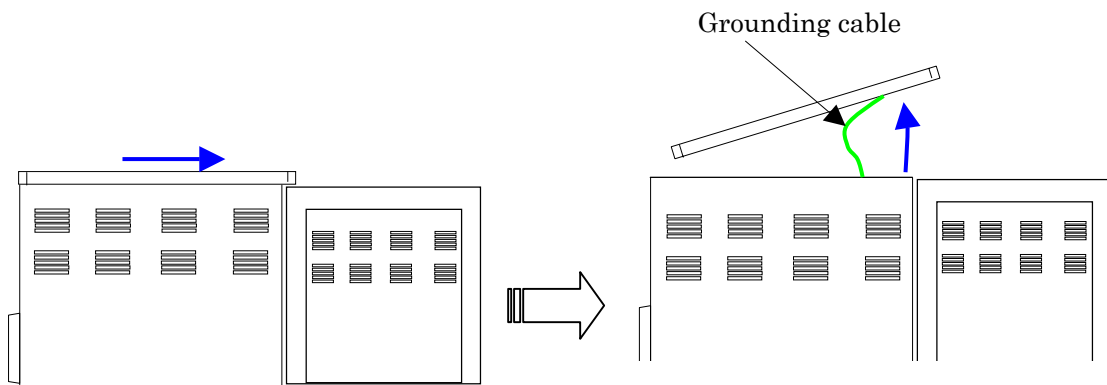

3) Remove a screw (M6) of either the top plate or the Base Unit. Never lose a removed screw.

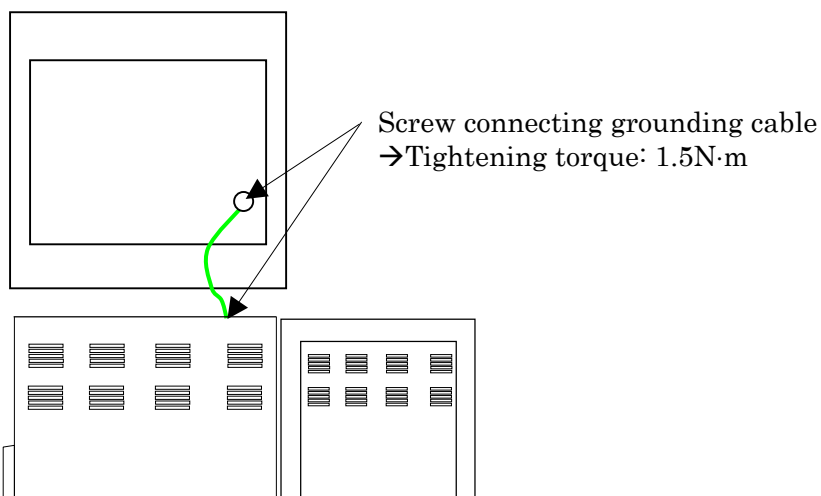

- 4) Remove 4 hexagon socket bolts (M12) from the top plate with hex wrench (10mm).
→Tightening torque: 5N·m

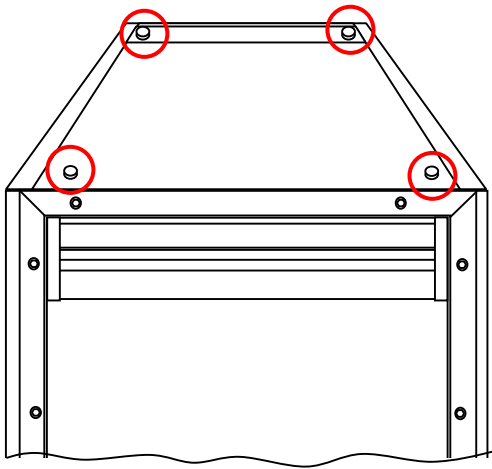

(Note)

When the Eyebolts are not used, hexagon socket bolts must be attached instead of the Eyebolts. Be sure not to let it be lost.

- 5) Mounting the Eyebolt
Mount the Eyebolt (M12) where the hexagon socket bolt was located.

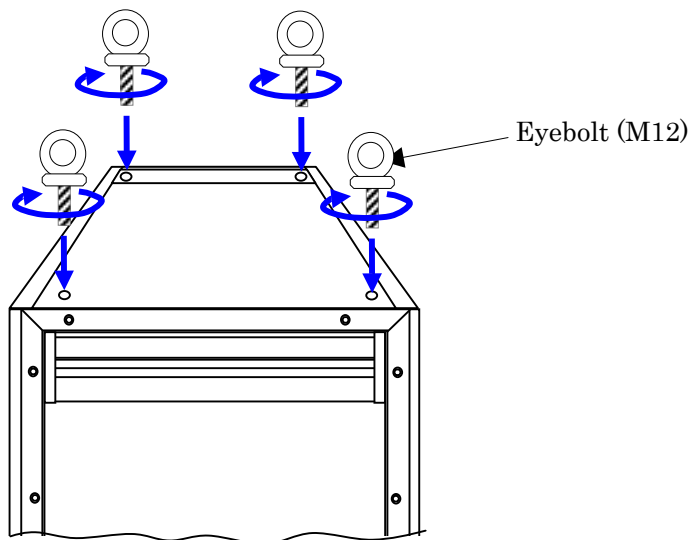

- 6) Removing the Eyebolt(M12)
To remove the Eyebolt (M12), reverse the procedure for mounting.

3.4.2 Fixing the Base Unit

- 1) Before installation, remove all panel covers for the mounting base and the Base Unit.

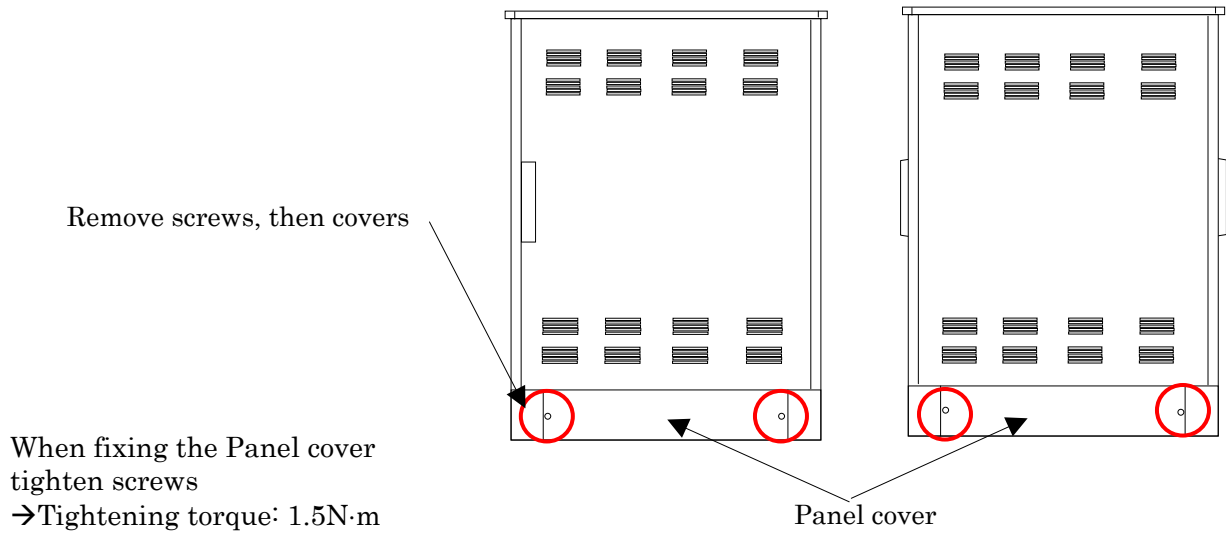

- 2) Fixing the mounting base to anchor bolts
Fix 4 corners of the mounting base to the anchor bolts.

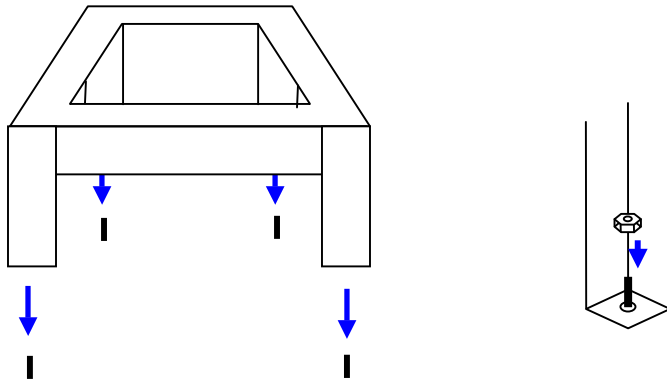

- 3) Fixing the Base Unit
Mount the Base Unit on the mounting base and fix 4 corners of the Base Unit with flat washer, spring washer and bolts.

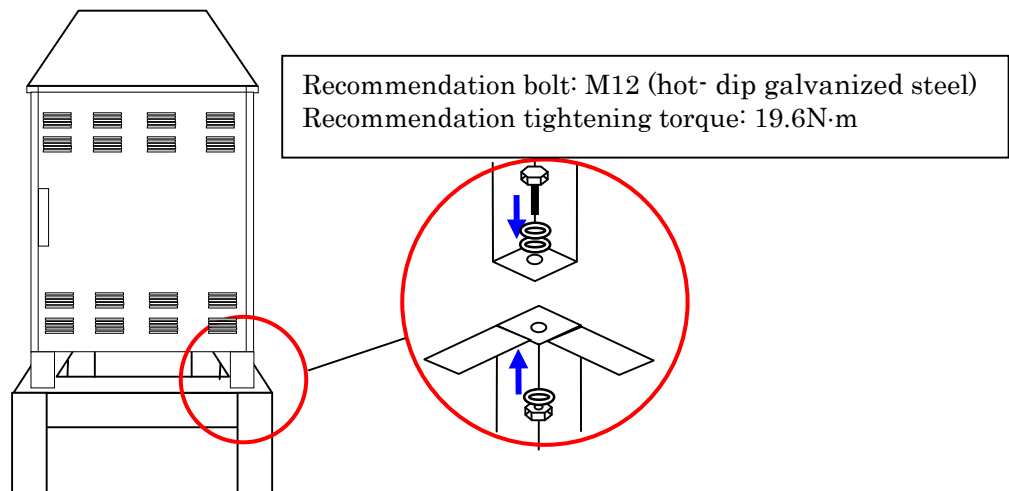

3.4.3 Connecting cables

Lead all the cables to the mounting base.
And open the front door.

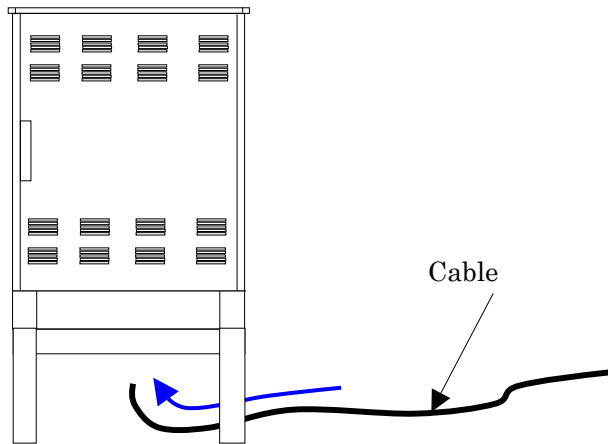

3.4.3.1 Connecting the AC power supply cable

1) Removing the AC terminal cover

Loosen a fixing screw and remove the AC terminal cover.

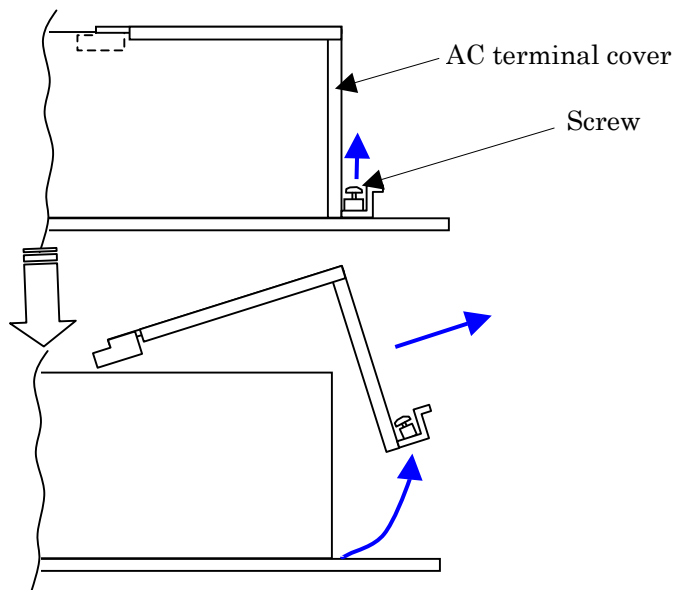
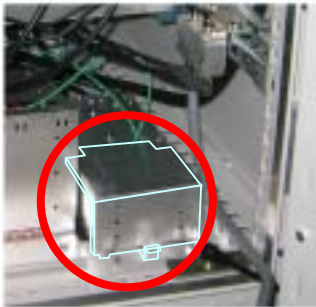

- 2) Removing the dome nut for the AC power supply cable
Remove the dome nut for the AC power supply cable at the bottom of the Base Unit and remove the cable packing.

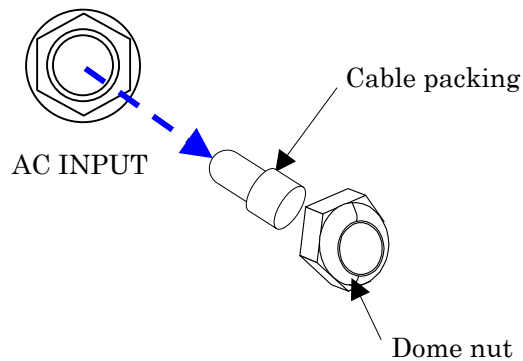

- 3) Pre-finishing the AC power supply cable
Put the AC power supply cable through the cold shrinkable tube, the dome nut and the cable packing in this order.
(See the following figure for the direction.)

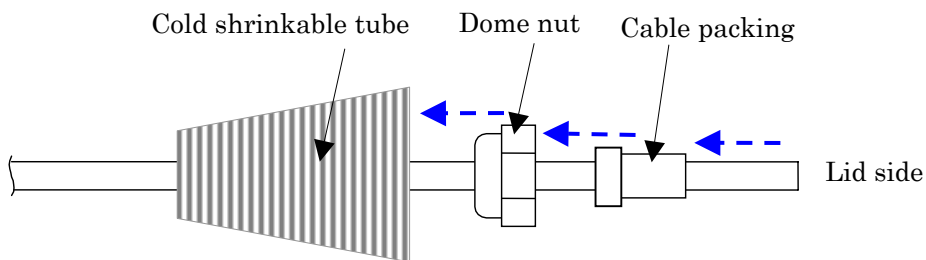

Peel the sheath off the AC power supply cable to expose the conductor.
→Peeling length of the sheath: 15 to 20 cm

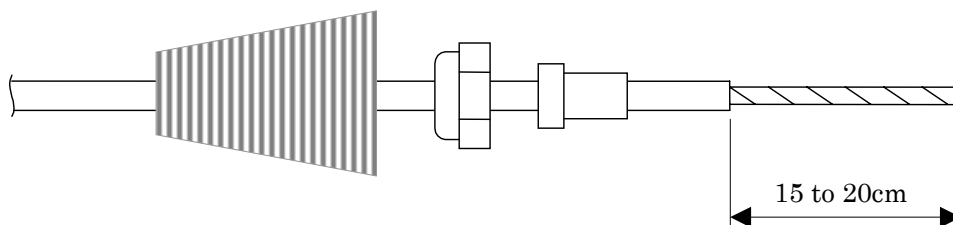

Loosen the copper shield and coil it around the conductor at the shield root part by more than 4 turns.

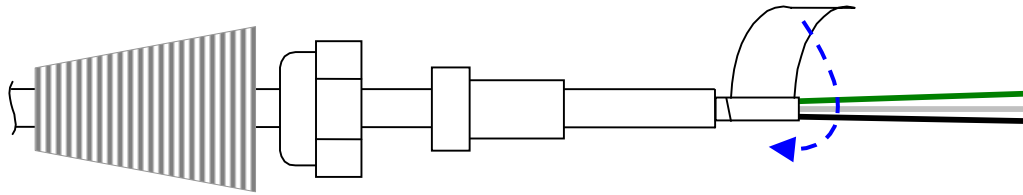

Peel the sheath off the 3 conductors.
→ Peeling length of the sheath: 10 mm

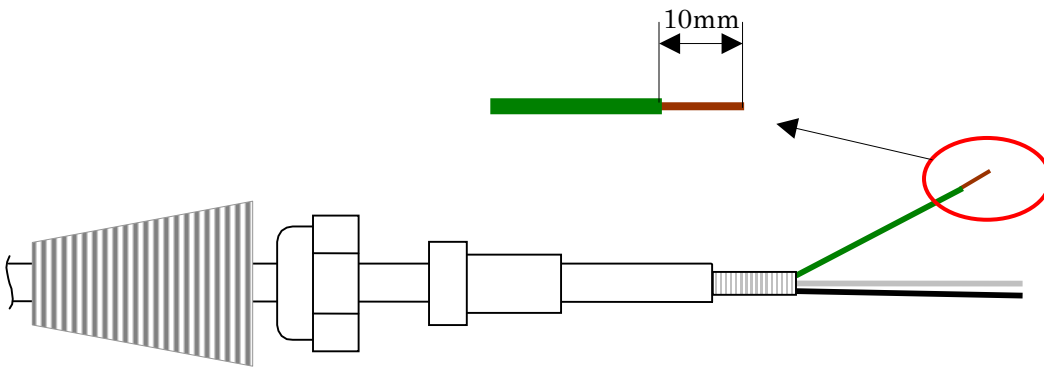

- 4) Inserting the AC power supply cable
Insert the AC power supply cable through the bushing into the Base unit.

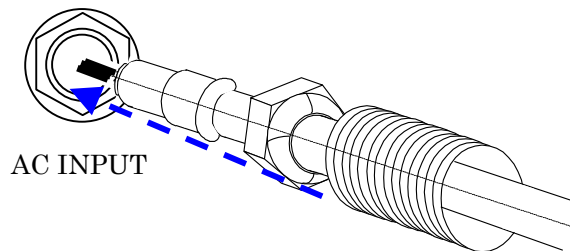

5) Fixing the cable clamp

Detach the one of the screws fixing the cable clamp for the AC power supply cable and then loosen the other screw. Adjust the cable clamp to the copper shield and tighten the screw again so as to make no space between the copper shield and the cable clamp.
→Tightening torque: 1.5N·m

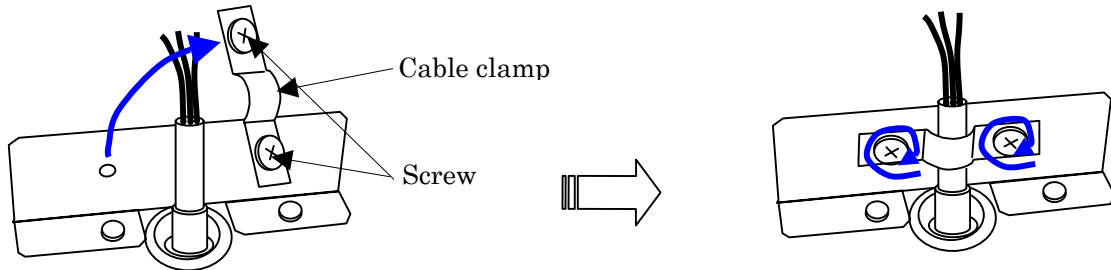

Note)

If fixing of the shield is incomplete, noise may be caused during communication or interference may be caused on other electronic devices.

6) Connecting the AC power supply cable to the AC terminal

With keeping the red arrowed point of the AC terminal depressed by a flat-head screwdriver (width: 3mm), insert the AC power supply cable and then release the cabinet screwdriver.
After insertion, verify that the cable cannot be removed.

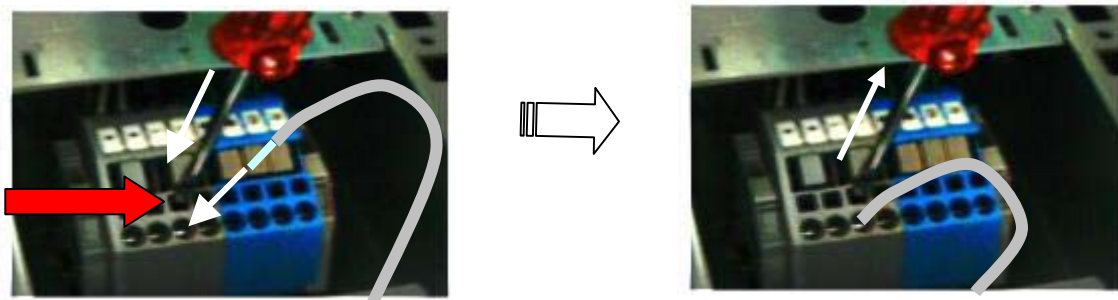

2 contact ports for each cable, Live, Neutral and GND, are available.

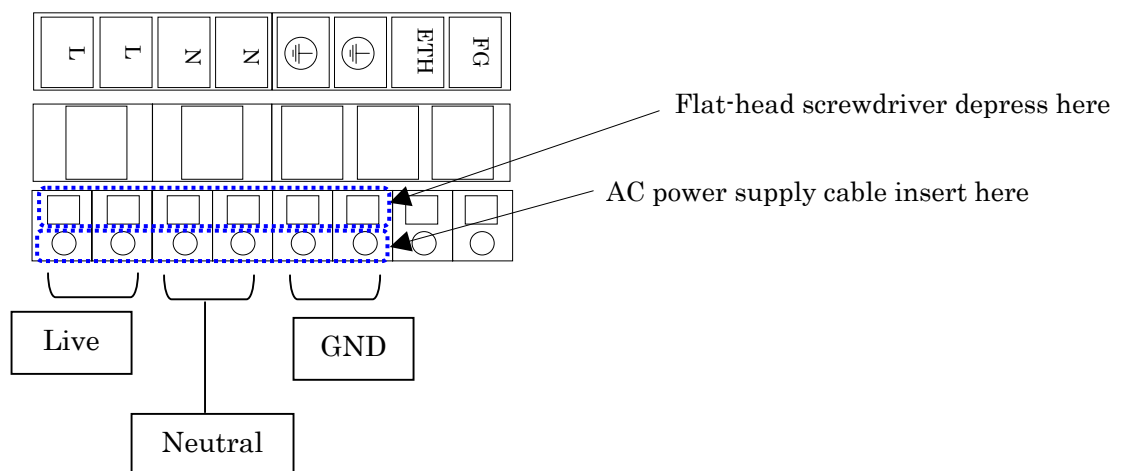

- 7) Tightening the dome nut
After inserting the cable packing, tighten the dome nut by hand and then retighten it with a torque wrench.
→ Tightening torque: 2.45N·m

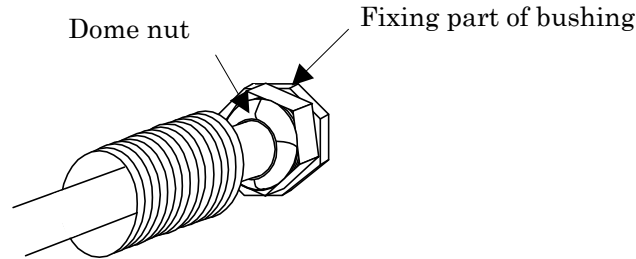

- 8) Waterproof treatment for the AC power supply cable
Cover the cold shrinkable tube over the root of the connector and shrink it.

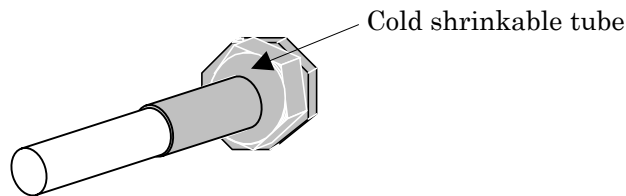

- 9) Mounting the AC terminal cover
Mount the AC terminal cover and tighten the AC terminal fixing screw with a specified torque.
→ Tightening torque: 1.5N·m

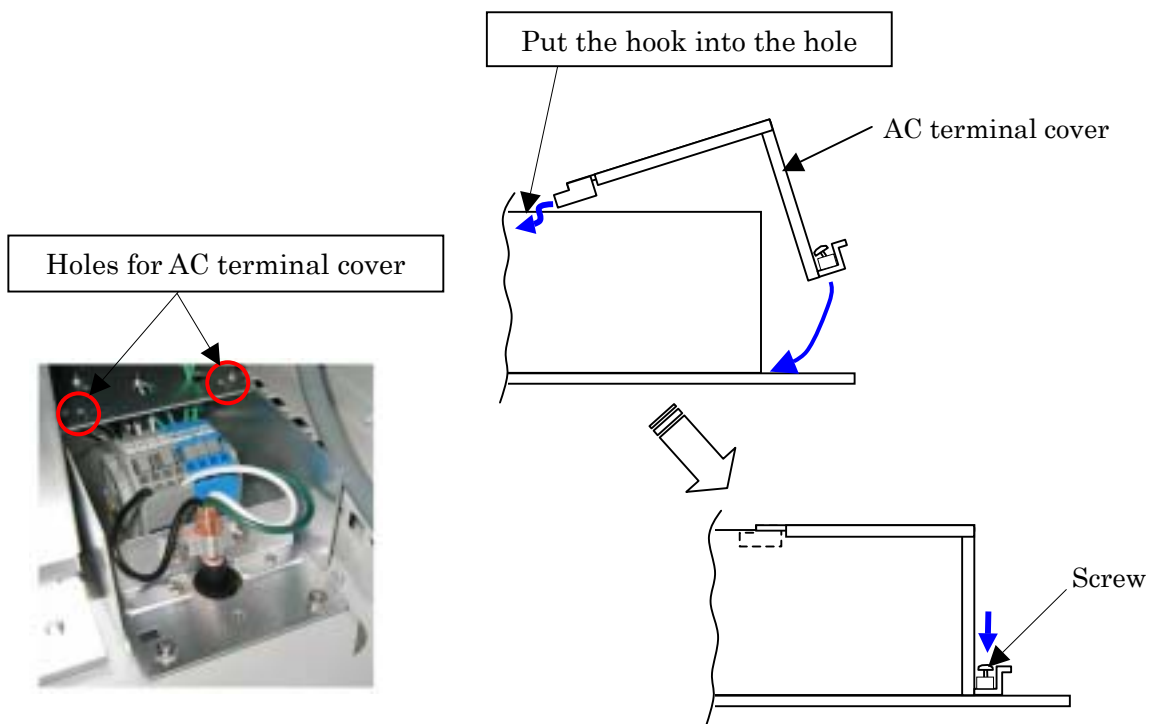

3.4.3.2 Fixing the grounding cable

1) Removing the bolt

Remove the bolt (M6) for fixing the grounding cable at the bottom of the Base Unit.

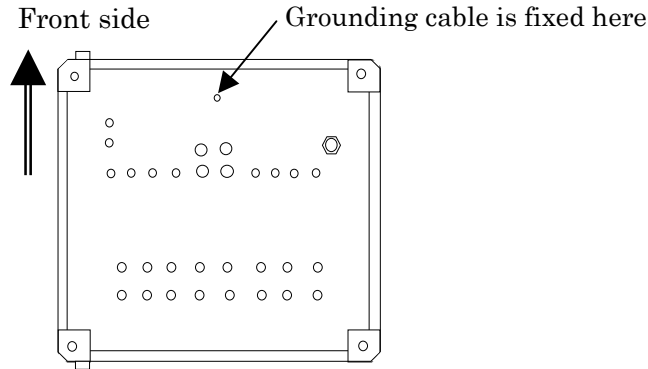

2) Fixing the grounding cable

Crimp the grounding cable (More than 6 mm²) to the terminal and fix the bolt (M6) with it.

→ Tightening torque: 1.5N·m

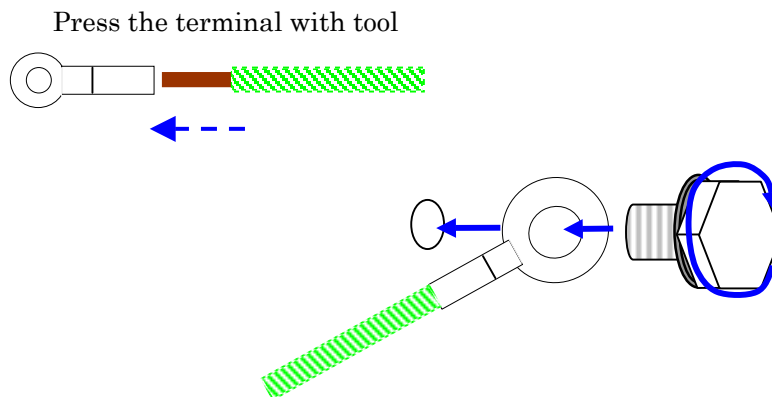

3) Connect the grounding cable to the place determined by the site survey.

3.4.3.3 Connecting the PA control cable

1) Removing the dome nut for the PA control cable

Remove the dome nut for the PA control cable at the bottom of the Base Unit and remove the cable packing.

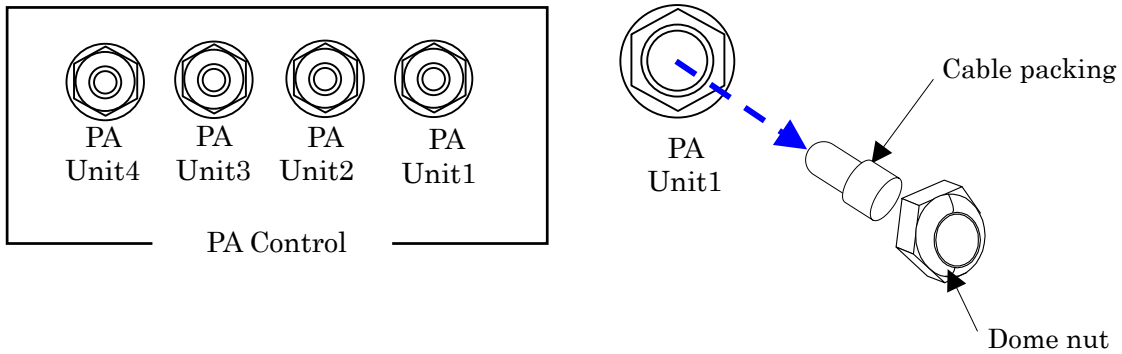

2) Pre-finishing the PA control cable

Put the PA control cable through the cold shrinkable tube, the dome nut and the cable packing in this order.
(See the following figure for the direction.)

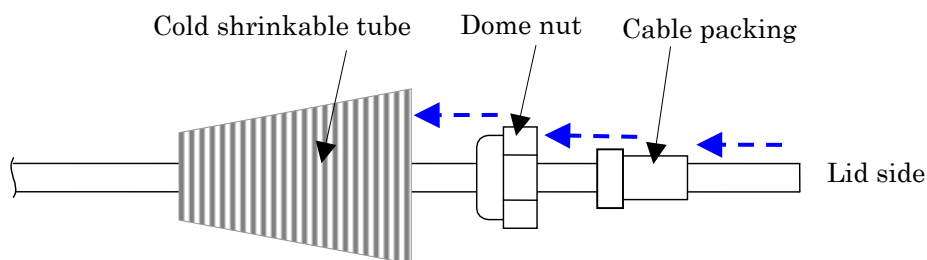

Peel the sheath off the PA control cable to expose the conductor.

→Peeling length of the sheath: 10 to 15 cm

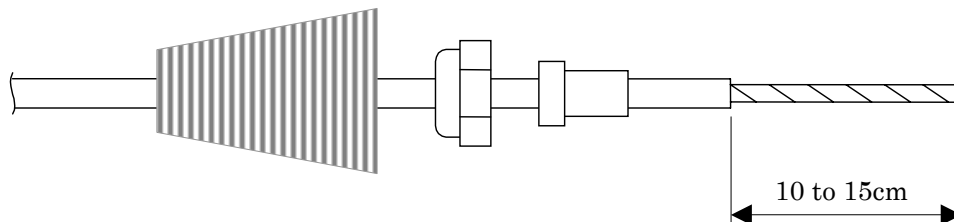

Loosen the copper shield and coil it around the conductor at the shield root part by more than 4 turns.

For the PA control cable, 3 pairs of twisted-pair cables are used.

If there are 4 pairs of cables, coil the cable with a tape to prevent the extra one pair from short circuit.

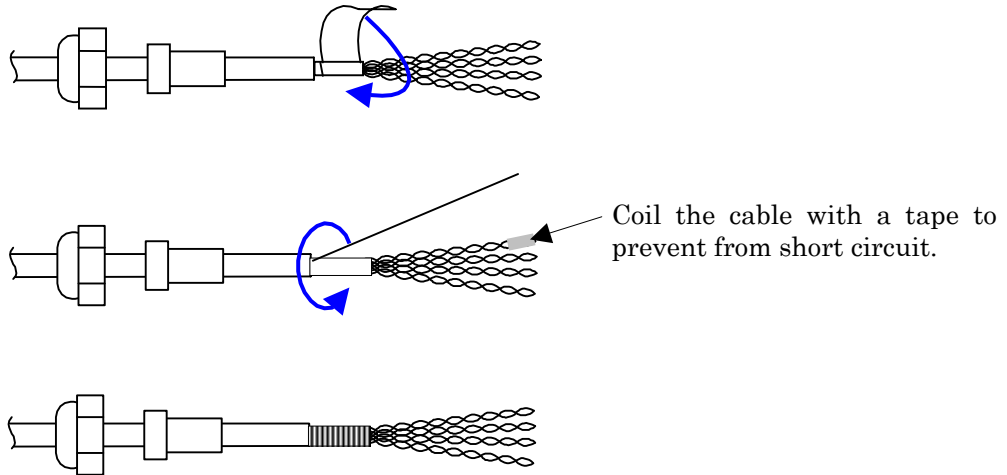

3) Removing the surge box cover for the PA control cable

Loosen 2 fixing screws and remove the surge box cover for the PA control cable.

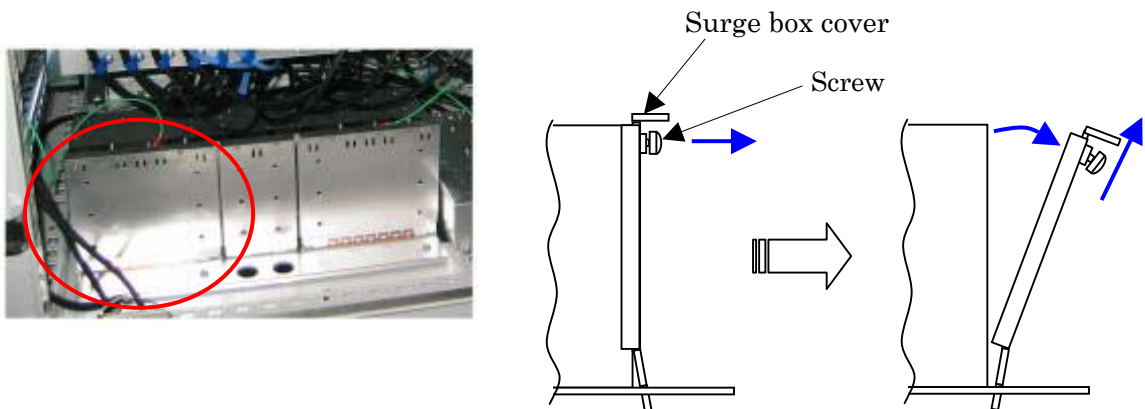

4) Removing the cable clamp for the PA control cable

Remove 2 screws fixing the cable clamp for the PA control cable and then remove the cable clamp.

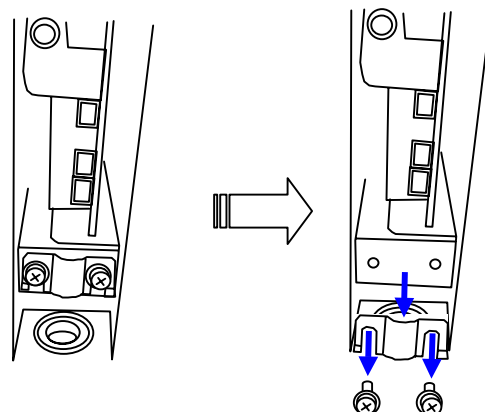

- 5) Inserting the PA control cable
 Insert the PA control cable through the bushing into the Base Unit.

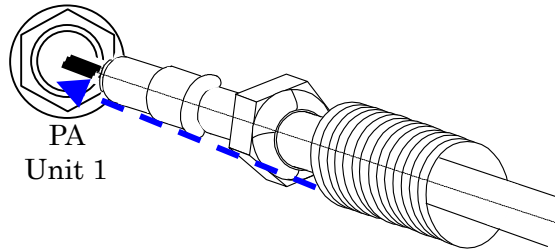

- 6) Fixing the cable clamp for the PA control cable
 Adjust the cable clamp to the copper shield and fix the screws so as to make no space between the copper shield and the cable clamp.
 →Tightening torque: 1.5N·m

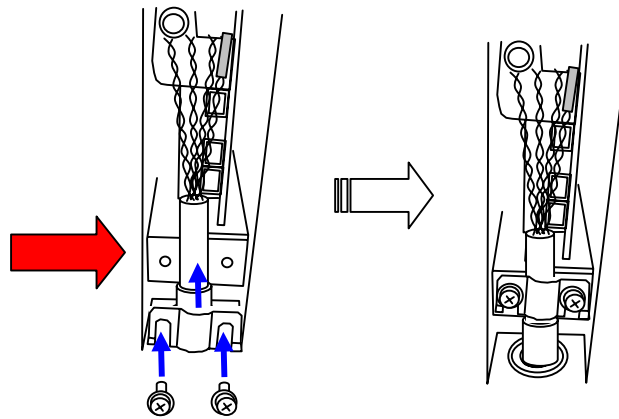

- 7) Press-connecting 232D connector
 Unstitch the conductor (3 pairs = 6 conductors) and connect them to the specified crimping connector.
 For the assignment of inserting conductor's 1pin and 2pin to the connector, refer to the following figure.
 Press the connector while inserting the conductors to the far end.
 Recommended connector: Press-contact connector manufactured by DDK (DDK Ltd.)
 Product No: 232D-02S1B-DA2

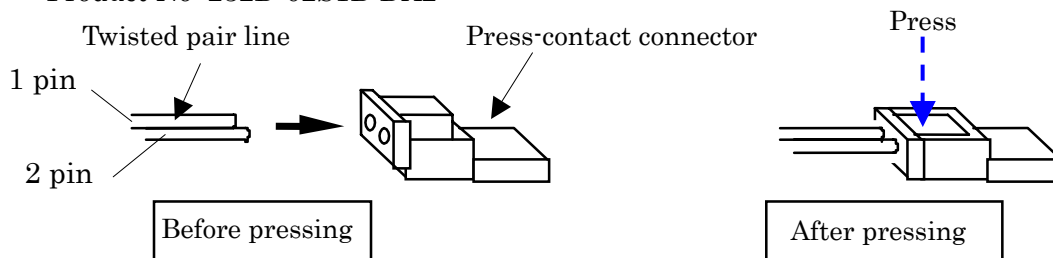

Frame-	2 pin	Blue / spiral
Frame+	1 pin	Blue
Rx-	2 pin	Green / spiral
Rx+	1 pin	Green
Tx-	2 pin	Orange / spiral
Tx+	1 pin	Orange

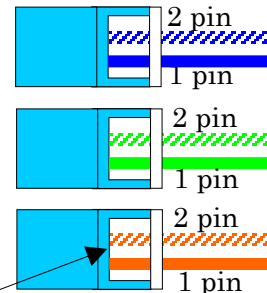

Press connector while the conductors are inserted to the far end.

- 8) Connecting the press-contact connector to the surge board
Insert the press-contacted connector to the (232D) connector on the surge board.

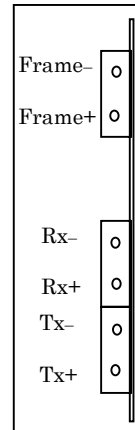
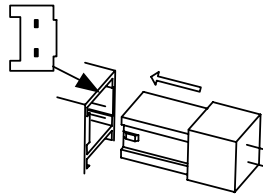

- 9) Forming the conductor
Form the conductor not to extend over the surge box.



- 10) Tightening the dome nut
After inserting the cable packing, tighten the dome nut by hand and then retighten it using a torque wrench.
→Tightening torque: 2.45N·m

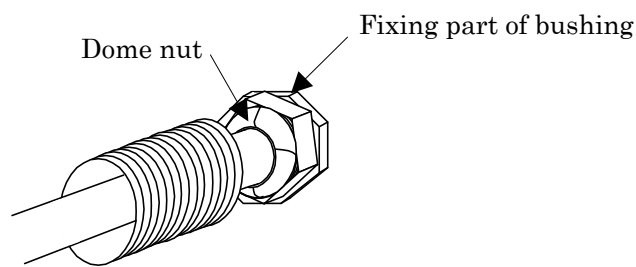

- 11) Waterproof treatment for the PA control cable
Cover the cold shrinkable tube over the root of the connector and shrink it.

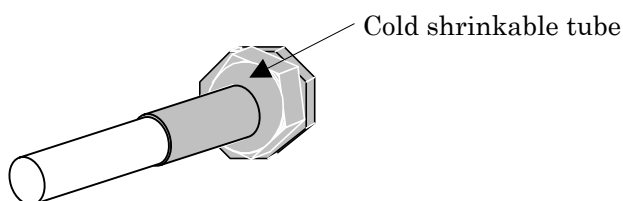

- 12) Apply the above PA control cable connecting steps for PA1 through PA4.



- 13) Mounting the surge box cover

Mount the surge box cover and tighten the surge box cover fixing screw with a specified torque.

→ Tightening torque: 1.5 N·m

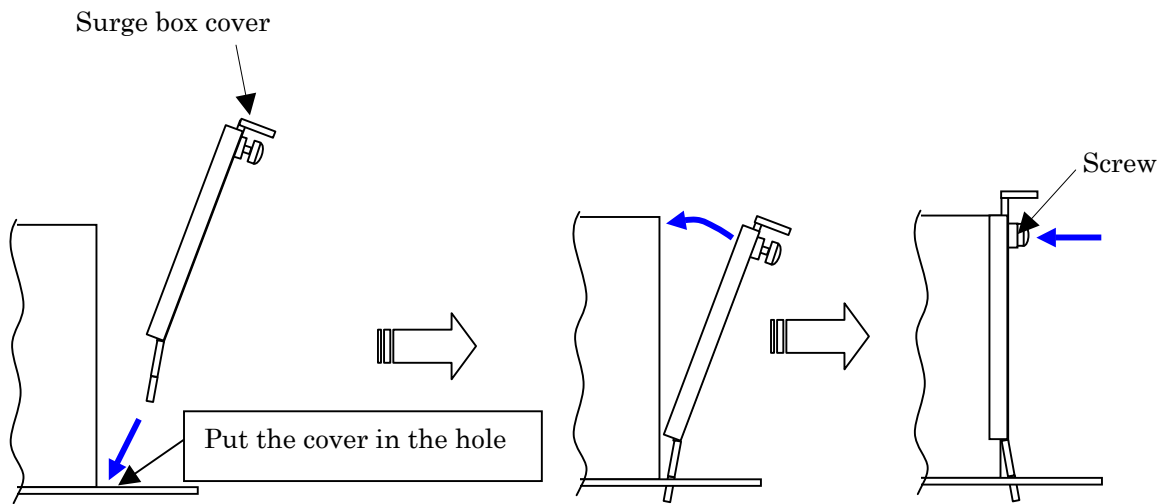

Holes for surge box cover

3.4.3.4 Connecting the GPS cable

1) Removing the dome nut for the GPS cable

Remove the dome nut for the GPS cable at the bottom of the Base Unit and remove the cable packing.

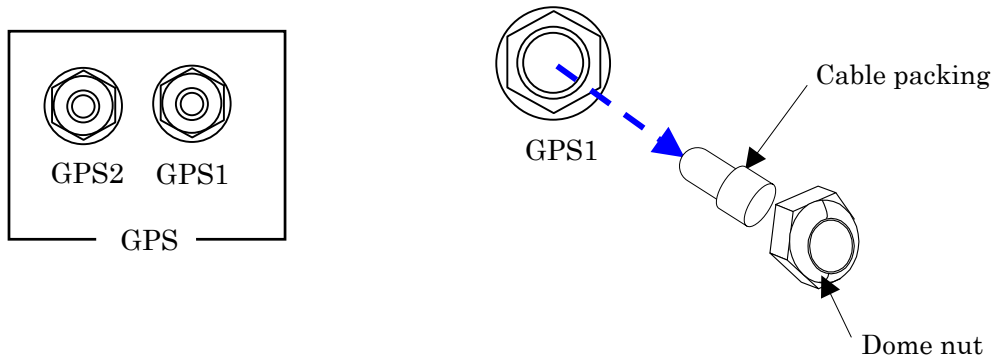

2) Pre-finishing the GPS cable

Put the GPS cable through the cold shrinkable tube, the dome nut and the cable packing in this order.
(See the following figure for the direction.)

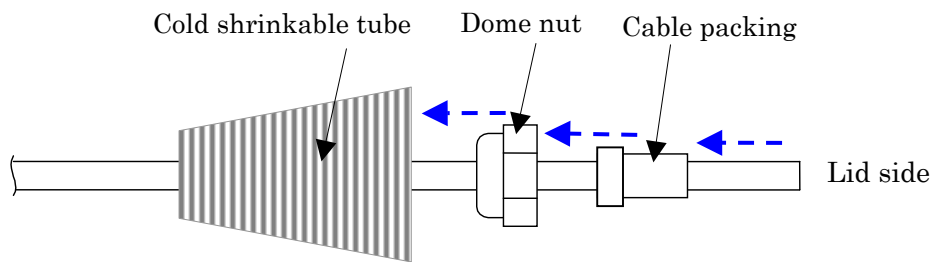

Peel the sheath off the PA control cable to expose the conductor.
→Peeling length of the sheath: 10 to 15 cm

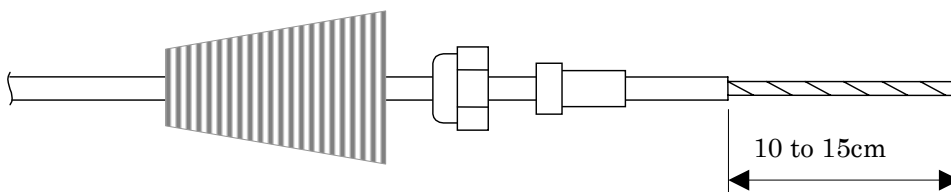

Loosen the copper shield and coil it around the conductor at the shield root part by more than 4 turns.

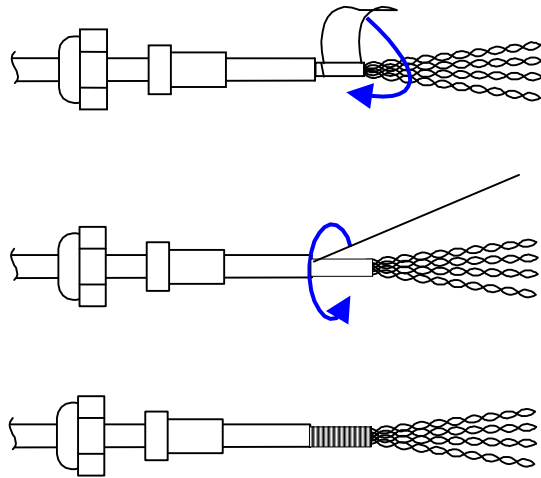

3) Removing the surge box cover for the GPS cable

Loosen 2 fixing screws and remove the surge box cover for the GPS cable.

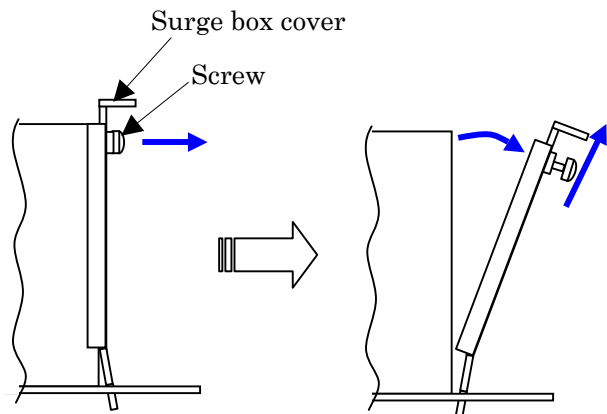
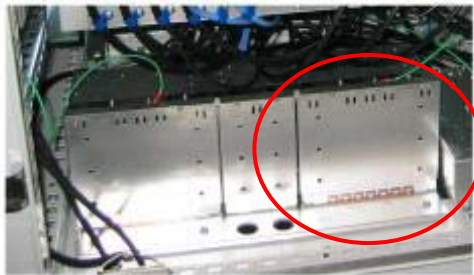

4) Removing the cable clamp for the GPS cable

Remove 2 screws fixing the cable clamp for the GPS cable and then remove the cable clamp.

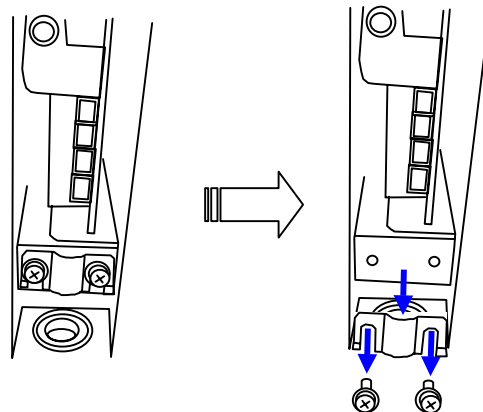

- 5) Inserting the GPS cable
 Insert the GPS cable through the bushing into the Base Unit.

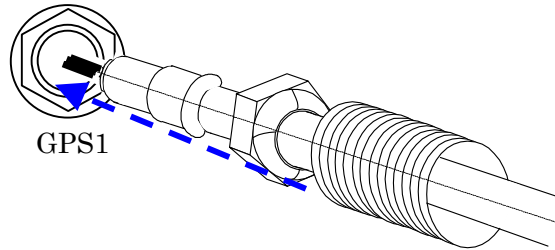

- 6) Fixing the cable clamp for th GPS cable
 Adjust the cable clamp to the copper shield and fix the screws so as to make no space between the copper shield and the cable clamp.
 →Tightening torque: 1.5N·m

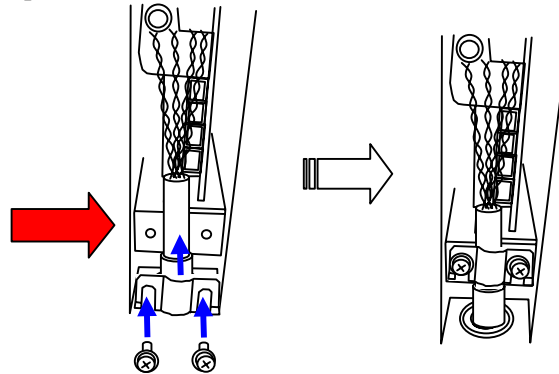

- 7) Press-connecting 232D connector
 Unstitch the conductor (4 pairs = 8 conductors) and connect them to the specified crimping connector.
 For the assignment of inserting conductor's 1pin and 2pin to the connector, refer to the following figure.
 Press the connector while inserting the conductors to the far end.
 Recommended connector: Press-contact connector manufactured by DDK (DDK Ltd.)
 Product No: 232D-02S1B-DA2

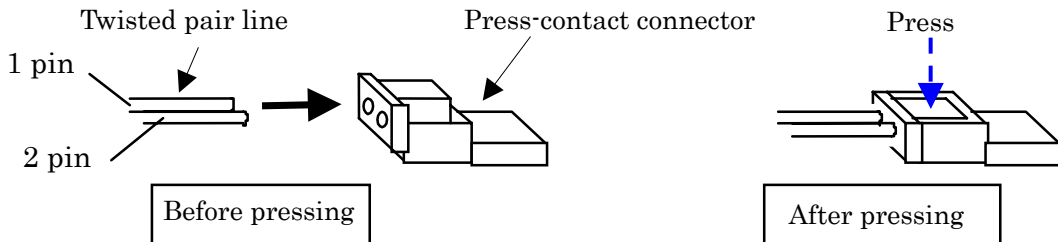

GND	2 pin	Brown
+12V	1 pin	Brown/spiral
RxD-	2 pin	Blue
RxD+	1 pin	Blue/spiral
TxD-	2 pin	Orange
TxD+	1 pin	Orange/spiral
1PPS-	2 pin	Green
1PPS+	1 pin	Green/spiral

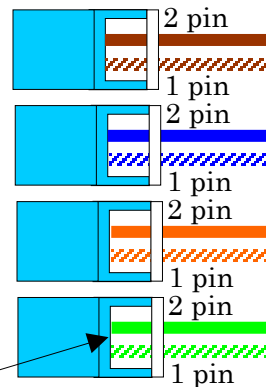

Press connector while the conductors are inserted to the far end.

- 8) Connecting the press-contact connector to the surge board
 Insert the press-contacted connector to the (232D) connector on surge board.

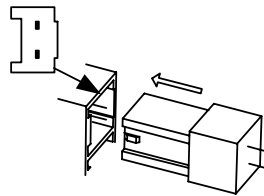

GND	○
+12V	○
RxD-	○
RxD+	○
TxD-	○
TxD+	○
1PPS-	○
1PPS+	○

- 9) Forming the conductor
 Form the conductor not to extend over the surge box.

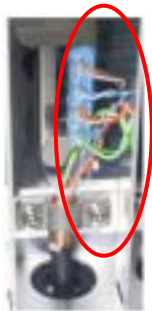

Note)
 The color of cables in the left photo defers from the table in “3.4.3.47) Press-connecting 232D connector”.

- 10) Tightening the dome nut
 After inserting the cable packing, tighten the dome nut by hand and then retighten it using a torque wrench.
 →Tightening torque: 2.45N·m

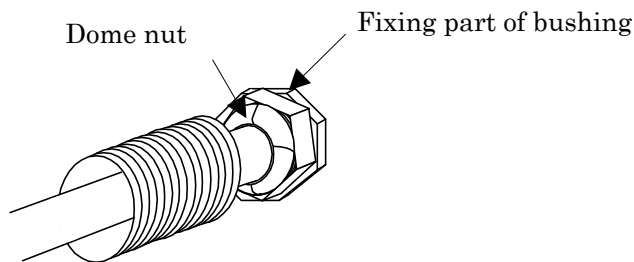

- 11) Waterproof treatment for the PA control cable
 Cover the cold shrinkable tube over the root of the connector and shrink it.

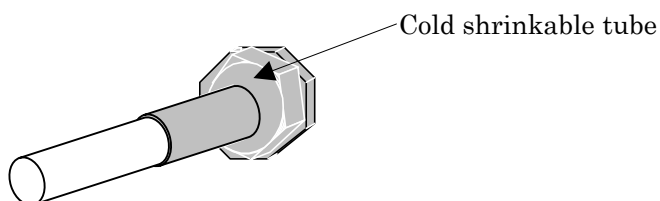

12) Apply the above GPS cable connecting steps for GPS1 through GPS2.



Note)
The color of cables in the left photo defers from the table in “3.4.3.47) Press-connecting 232D connector”.

13) Mounting the surge box cover

Mount the surge box cover and tighten the surge box cover fixing screw with a specified torque.

→ Tightening torque: 1.5N·m

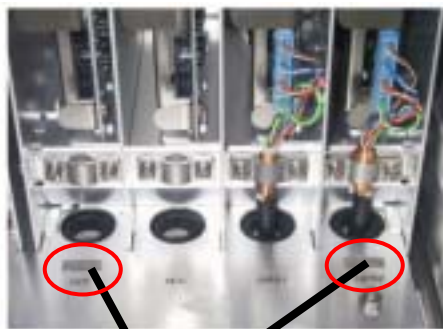
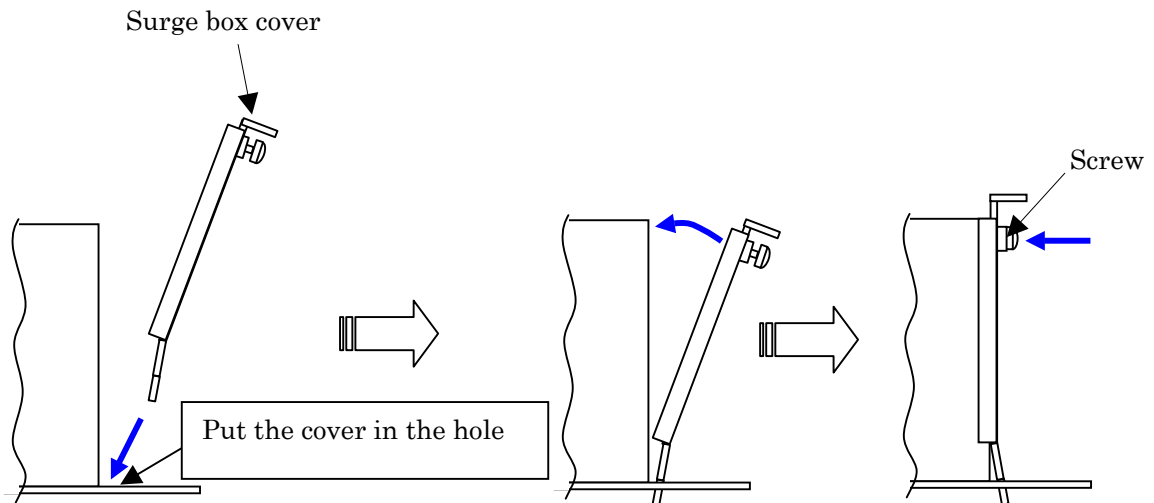

Holes for surge box cover

Note)
The color of cables in the left photo defers from the table in “3.4.3.47) Press-connecting 232D connector”.

3.4.3.5 Connecting the Calibration cable

There are two methods in connecting the Calibration cable.

3.4.3.5.1 Star connection

Refer to figure of 2.1.3.2.1

1) Removing the dustproof cap

Remove the dustproof cap attached to CAL1, 2, 3 and 4 at the bottom of the Base Unit.

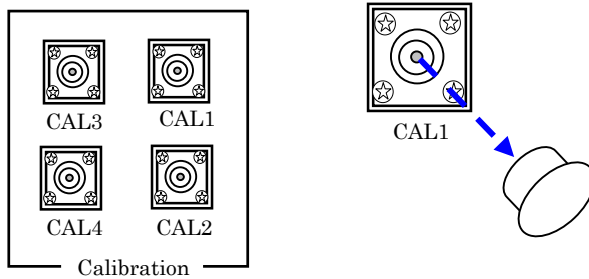

2) Pre-finishing the Calibration cable

Put the Calibration cable from the PA unit 1 through the cold shrinkable tube. (See the following figure for the direction.)

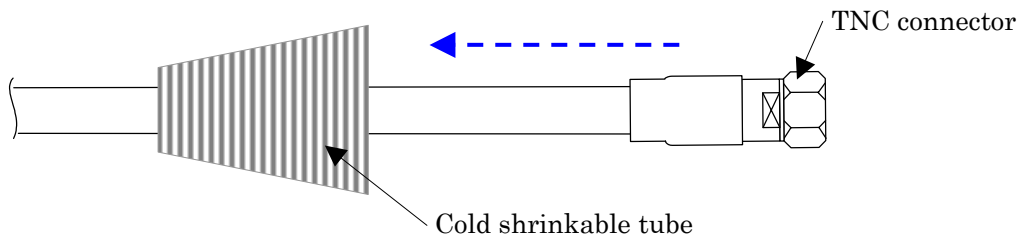

3) Connecting to CAL connector

Connect the Calibration cable to the connector of CAL1 on the Base Unit with the specified torque.

→Tightening torque: 0.45 to 0.69N·m

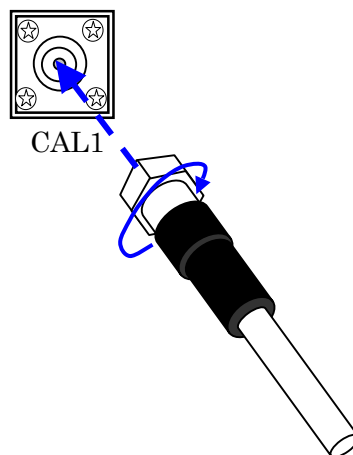

- 4) Waterproof treatment of the Calibration cable
Cover the cold shrinkable tube over the root of the connector and shrink it.

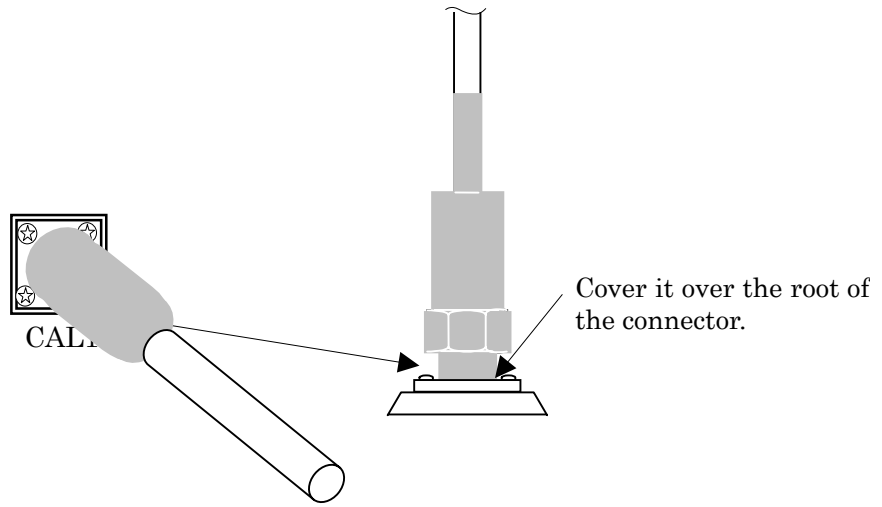

- 5) Connecting to CAL2, CAL3 and CAL4
Connect to CAL2, 3 and 4 as same sequence as of CAL1.

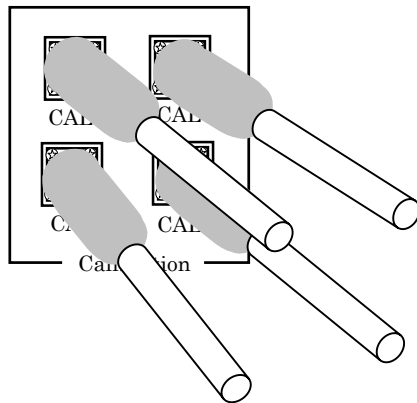

3.4.3.5.2 Daisy-chain connection

Refer to figure of 2.1.3.2.2

1) Removing the dustproof caps

Remove the dustproof cap attached to CAL1, 2, 3 and 4 at the bottom of the Base Unit.

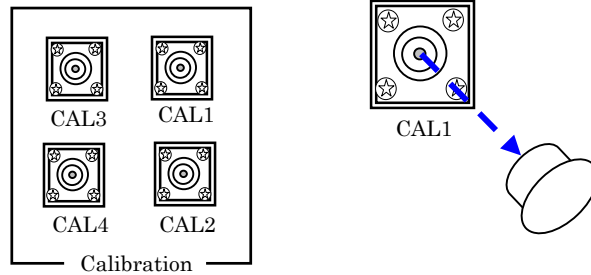

2) Pre-finishing the Calibration cable from the PA Unit 1

Put the Calibration cable from the PA Unit 1 through the cold shrinkable tube. (See the following figure for the direction.)

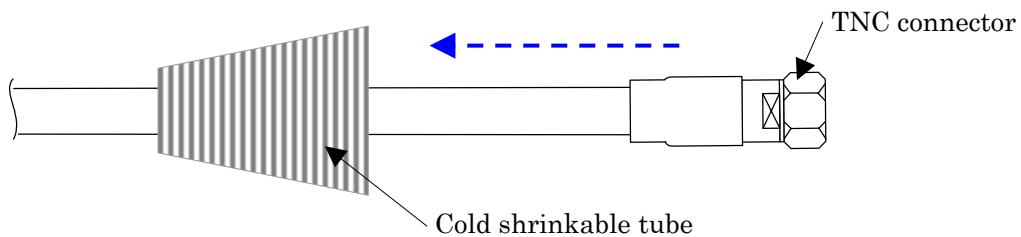

3) Connecting to CAL1

Connect the Calibration cable to the connector of CAL1 on the Base Unit with the specified torque.

→Tightening torque: 0.45 to 0.69N·m

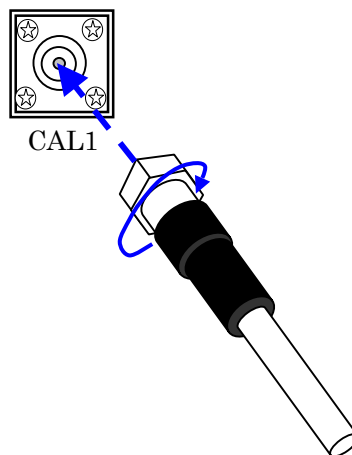

- 4) Waterproof treatment of the Calibration cable
Cover the cold shrinkable tube over the root of the connector and shrink it.

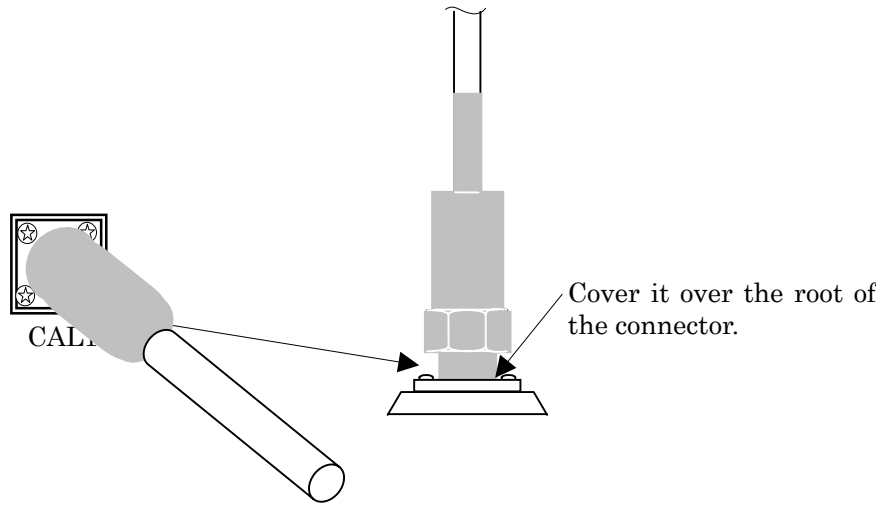

- 5) Connecting to CAL3
Connect the Calibration cable from PA Unit 3 to CAL3 as same sequence as of CAL1.

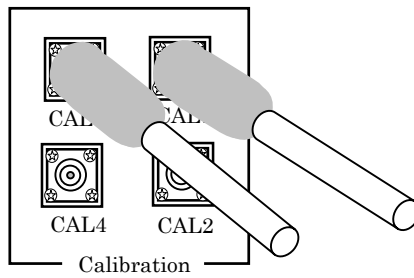

- 6) Mounting the terminator to CAL2
Mount the terminator to CAL2 on the Base Unit.
→Tightening torque: 0.45 to 0.69N·m

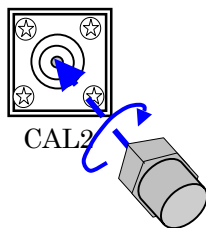

- 7) Waterproof treatment of the terminator
Wind a self-fusing rubber tape and then a vinyl tape around the terminator.

Cover it over the root of the connector.

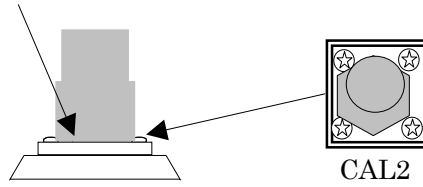

- 8) Connecting the terminator to CAL4
Connect the terminator to CAL4 as same sequence as of CAL2.

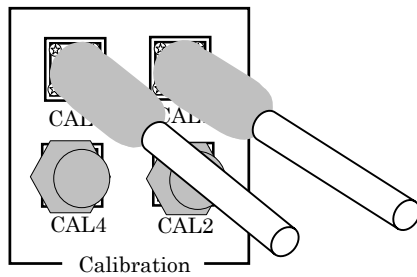

3.4.3.6 Connecting the PU-BU RF cable

Connect the PU-BU RF cable of the PA unit, from PA unit 1 to PA unit 4, in order.

1) Removing the dustproof cap

Remove the dustproof cap attached to RF1, 2 and 3 of the PA Unit 1, 2, 3 and 4 at the bottom of the Base Unit.

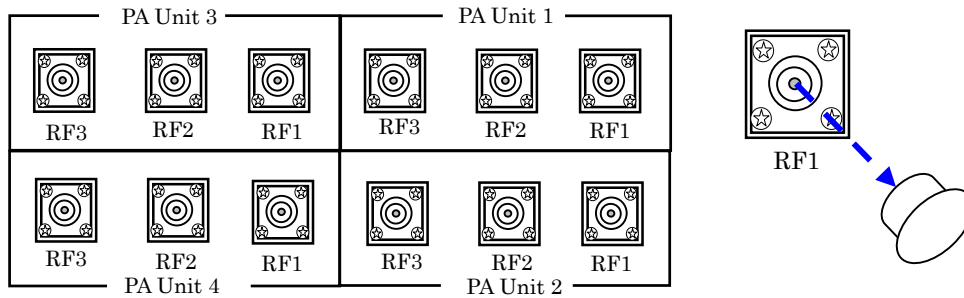

2) Pre-finishing the PU-BU RF cable

Put the PU-BU RF cable from RF1 of the PA Unit 1 through the cold shrinkable tube. (See the following figure for the direction.)

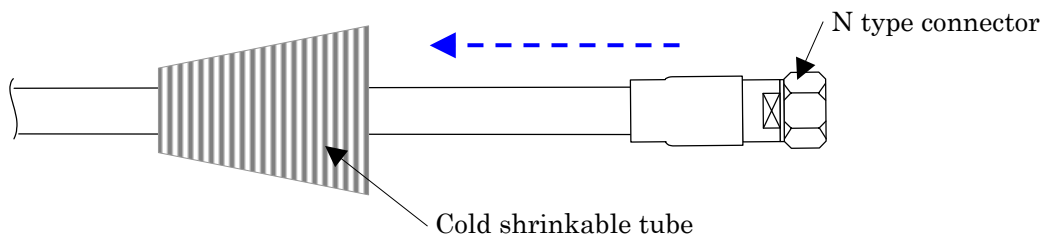

3) Connecting the PU-BU RF cable

Connect the PU-BU RF cable to the connector of RF1 on the Base Unit with the specified torque.

→ Tightening torque: 1.96 to 2.94N·m

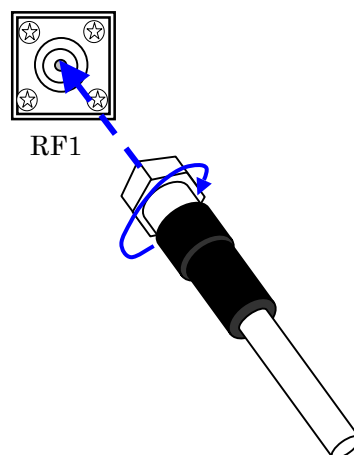

- 4) Waterproof treatment of the PU-BU RF cable
Cover the cold shrinkable tube over the root of the connector and shrink it.

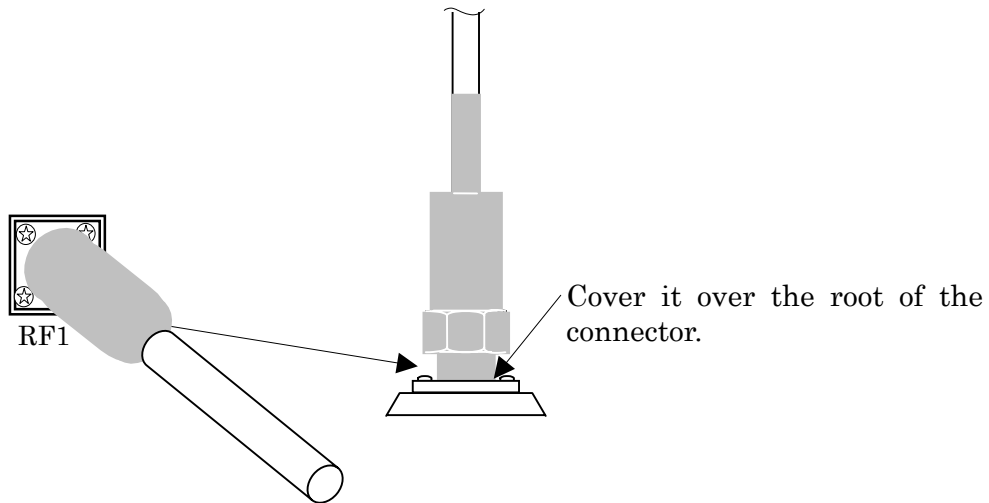

- 5) Pre-finishing the PU-BU RF cable
Put the PU-BU RF cable from RF2 of the PA Unit 1 through the cold shrinkable tube. (See the following figure for the direction.)

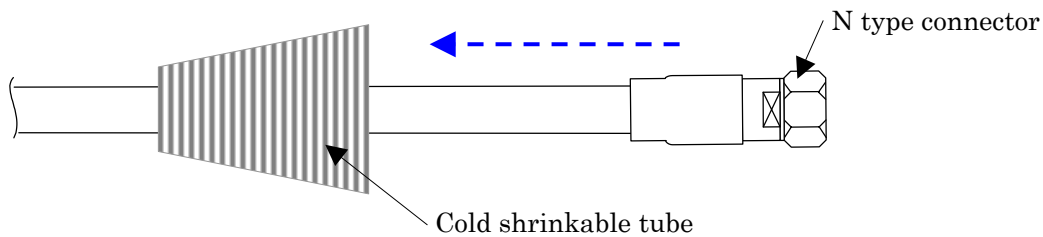

- 6) Connecting the PU-BU RF cable
Connect the PU-BU RF cable to the connector of RF2 on the Base Unit with the specified torque.
→Tightening torque: 1.96 to 2.94N·m

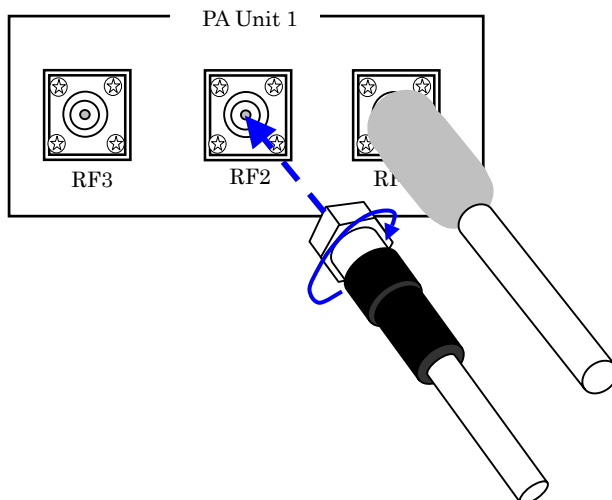

- 7) Waterproof treatment of the PU-BU RF cable
Cover the cold shrinkable tube over the root of the connector and shrink it.

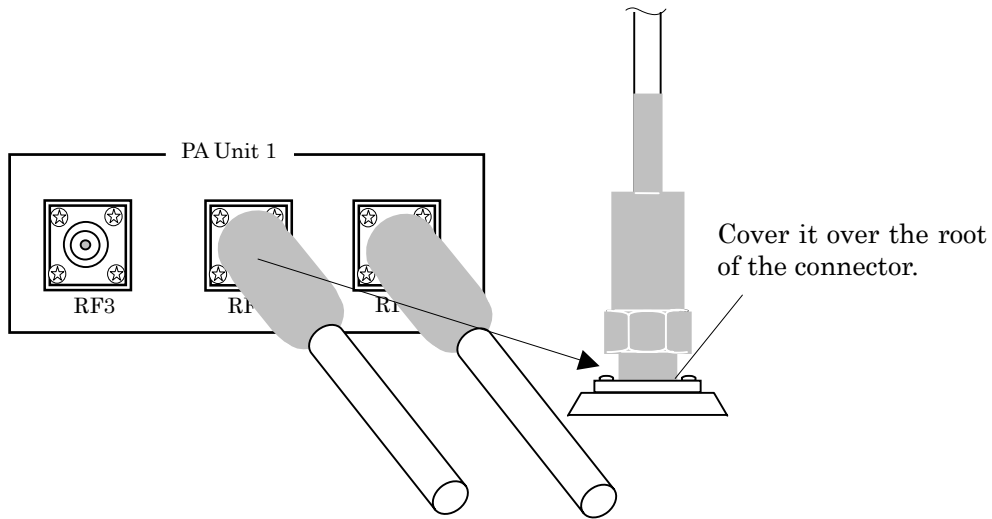

- 8) Pre-finishing the PU-BU RF cable
Put the PU-BU RF cable from RF3 of the PA Unit 1 through the cold shrinkable tube. (See the following figure for the direction.)

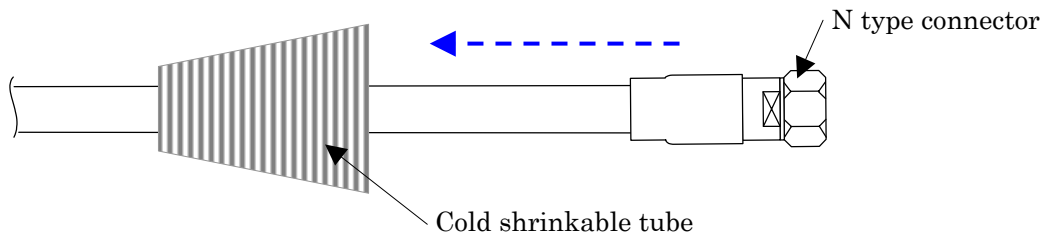

- 9) Connecting the PU-BU RF cable
Connect the PU-BU RF cable to the connector of RF3 on the Base Unit with the specified torque.
→Tightening torque: 1.96 to 2.94N·m

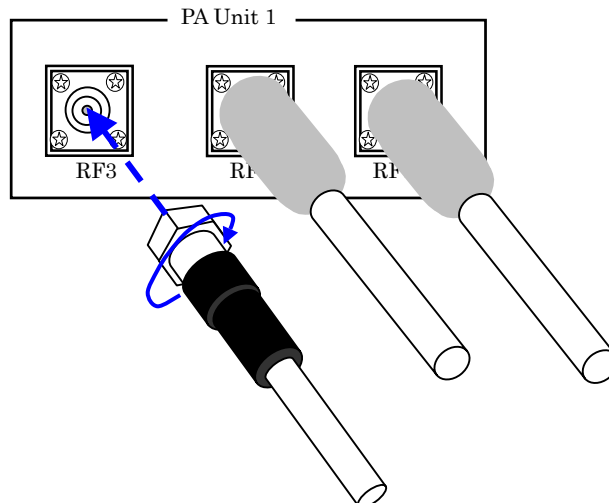

- 10) Waterproof treatment of the PU-BU RF cable
Cover the cold shrinkable tube over the root of the connector and shrink it.

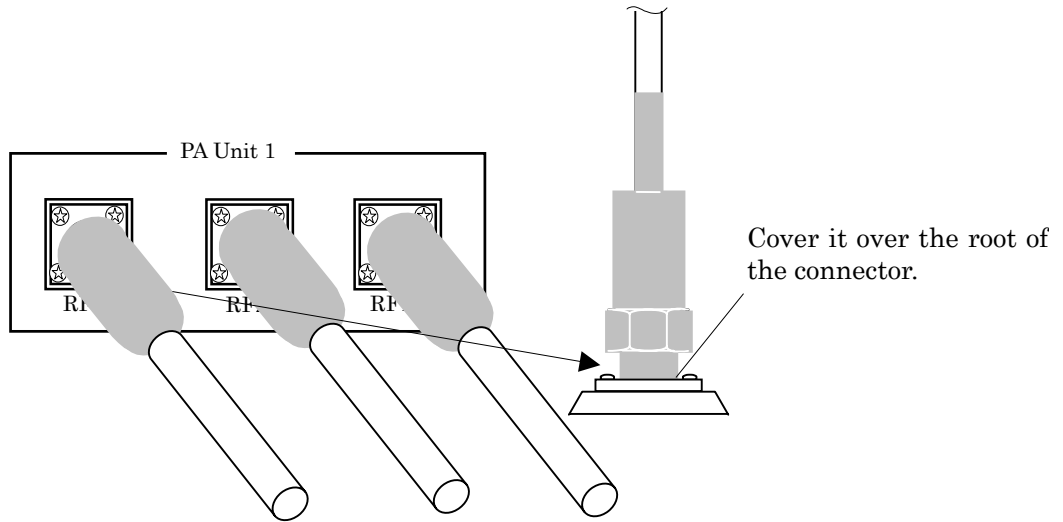

- 11) Connecting the PU-BU RF cable from the PA Unit 2, the PA Unit 3 and the PA Unit 4

Connect the PU-BU RF cable from RF1, 2 and 3 of Each PA Unit, from the PA Unit 2 to the PA Unit 4, to RF1, 2 and 3 of the Base Unit (marked from PA Unit 2, to PA Unit 4) as same sequence as the PU-BU RF cable from the PA Unit 1.

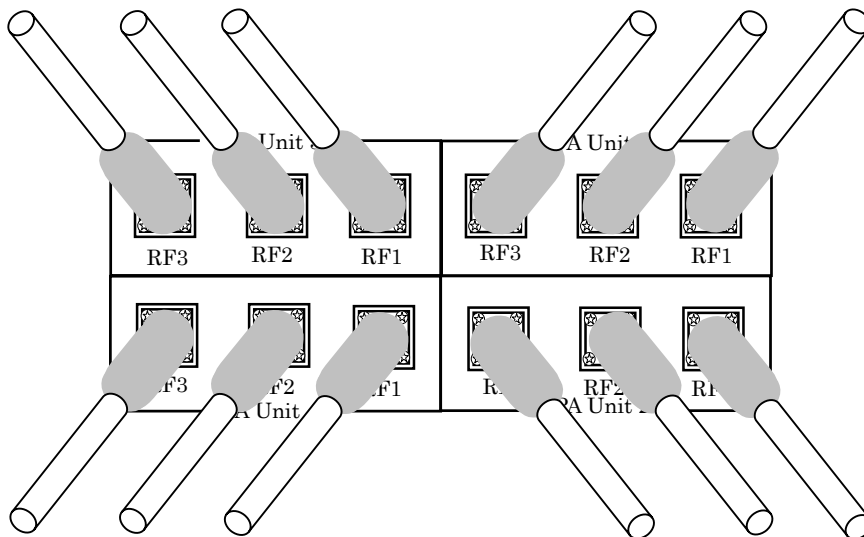

3.4.3.7 Connecting the Network cable

1) Removing the dome nut for the Network cable

Remove the dome nut for the Network cable at the bottom of the Base Unit and remove the cable packing.

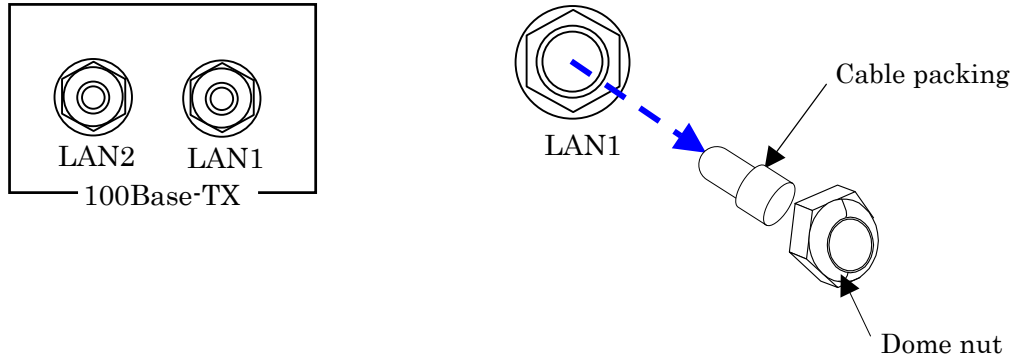

2) Pre-finishing the Network cable

Put the Network cable through the cold shrinkable tube, the dome nut and the cable packing in this order.
(See the following figure for the direction.)

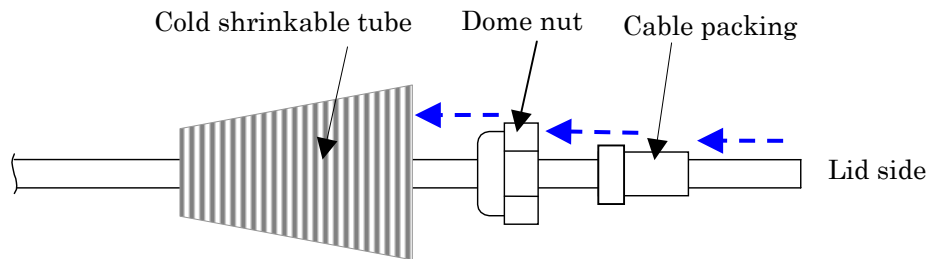

Peel the sheath off the Network cable to expose the conductor.
→Peeling length of the sheath: 10 to 15 cm

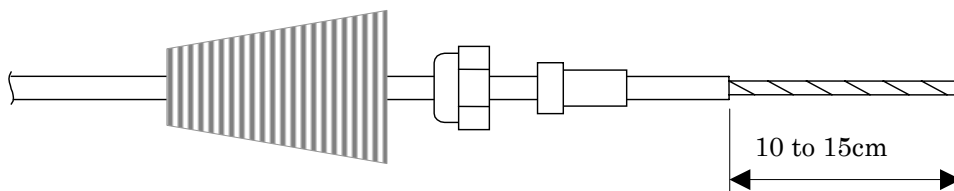

Loosen the copper shield and coil it around the conductor at the shield root part by more than 4 turns.

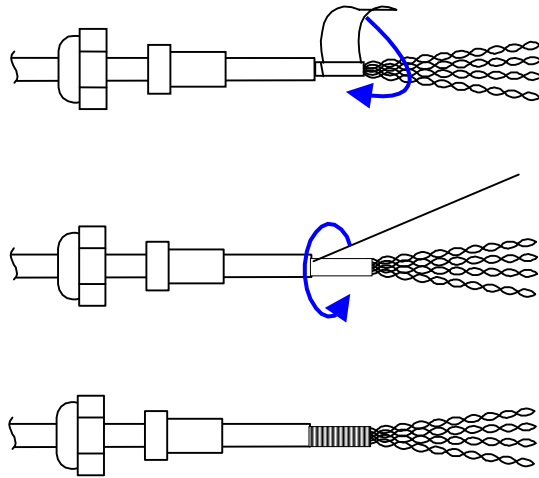

- 3) Removing the surge box cover for the Network cable
Loosen 2 fixing screws and remove the surge box cover for the Network cable.

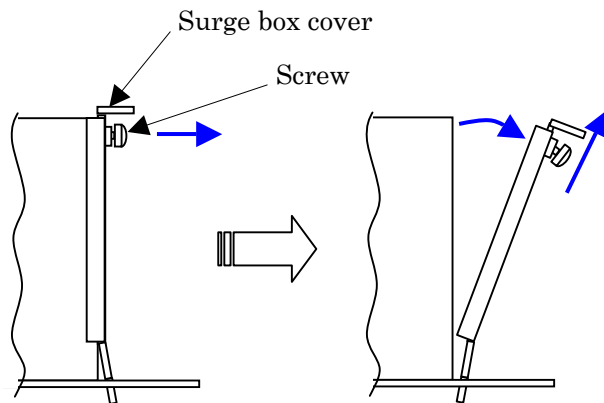
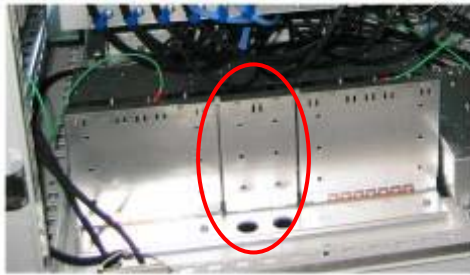

- 4) Removing the cable clamp for the Network cable
Remove 2 screws fixing the cable clamp for the Network cable and then remove the cable clamp.

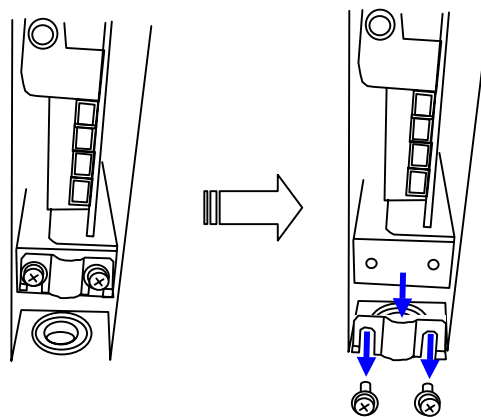

- 5) Inserting the Network cable
 Insert the Network cable through the bushing into the Base Unit.

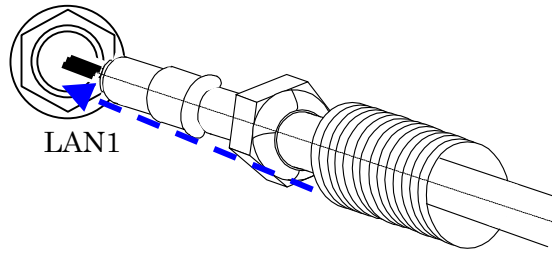

- 6) Fixing the cable clamp for the Network cable
 Adjust the cable clamp to the copper shield and fix the screws so as to make no space between the copper shield and the cable clamp.
 →Tightening torque: 1.5N·m

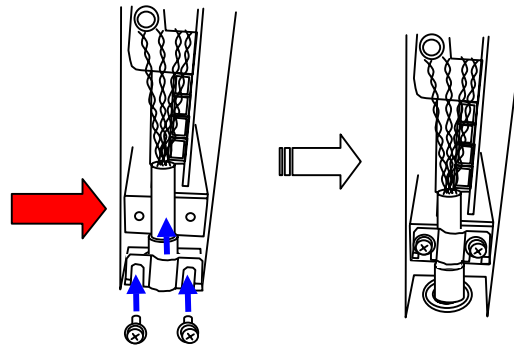

- 7) Press-connecting 232D connector
 Unstitch the conductor (4 pairs = 8 conductors) and connect them to the specified crimping connector.
 For the assignment of inserting conductor's 1pin and 2pin to the connector, refer to the following figure.
 Press the connector while inserting the conductors to the far end.
 Recommended connector: Press-contact connector manufactured by DDK (DDK Ltd.)
 Product No: 232D-02S1B-DA2

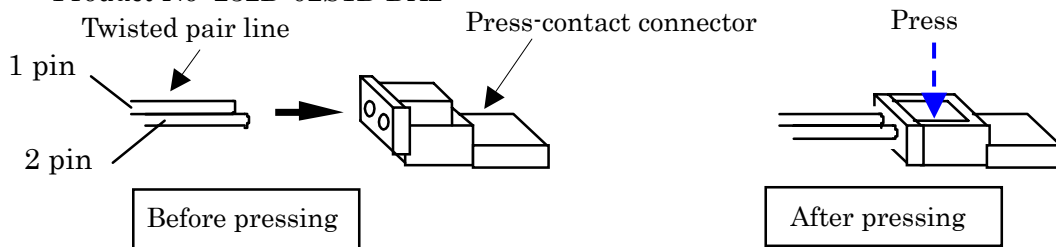

Reserve1-	2 pin	Brown
Reserve1+	1 pin	Brown/ spiral
Reserve2-	2 pin	Blue
Reserve2+	1 pin	Blue/ spiral
RxD-	2 pin	Orange
RxD+	1 pin	Orange/ spiral
TxD-	2 pin	Green
TxD+	1 pin	Green/ spiral

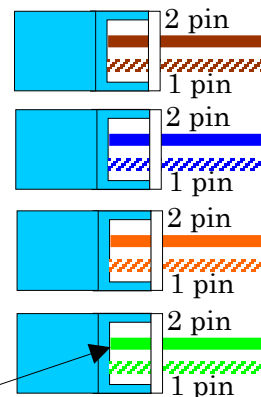

Press connector while the conductors are inserted to the far end.

- 8) Connecting the press-contact connector to the surge board
Insert the press-contacted connector to the (232D) connector on the surge board.

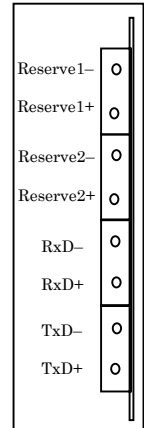
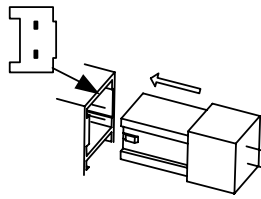

- 9) Forming the conductor
Form the conductor not to extend over the surge box.

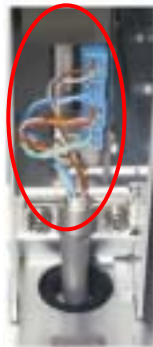

- 10) Tightening the dome nut
After inserting the cable packing, tighten the dome nut by hand and then retighten it using a torque wrench.
→Tightening torque: 2.45N·m

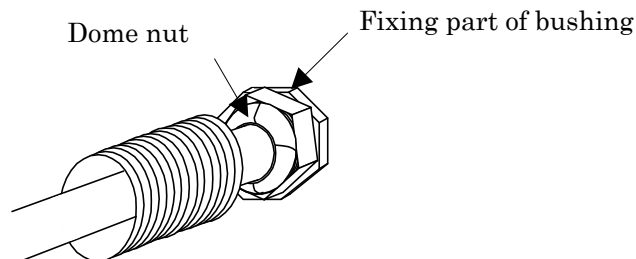

- 11) Waterproof treatment for the Network cable
Cover the cold shrinkable tube over the root of the connector and shrink it.

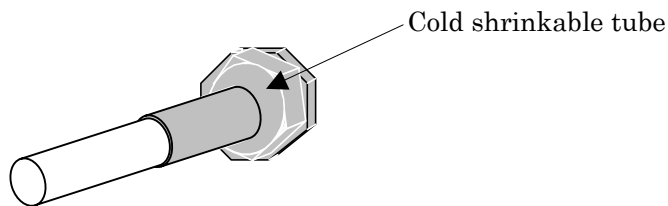

12) Apply the above Network cable connecting steps for LAN1 through LAN2.



13) Mounting the surge box cover

Mount the surge box cover and tighten the surge box cover fixing screw with a specified torque.

→ Tightening torque: 1.5N·m

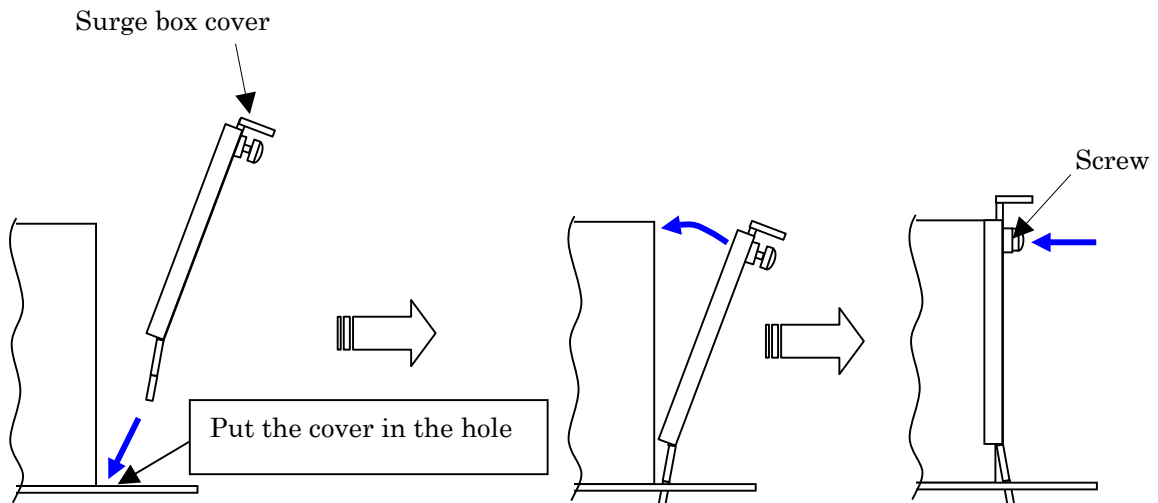

Holes for surge box cover

3.4.3.7.2 Connecting the GPI cable

1) Removing the dome nut for the GPI cable

Remove the dome nut for the GPI cable at the bottom of the Base Unit and remove the cable packing.

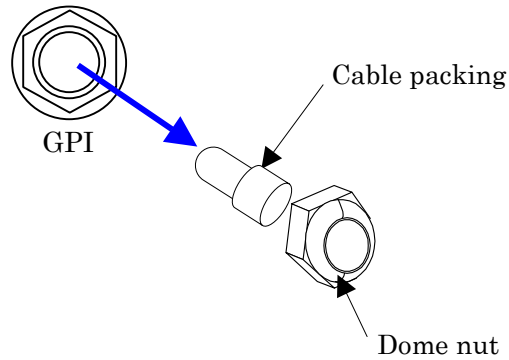

2) Pre-finishing the GPI cable

Put the GPI cable through the cold shrinkable tube, the dome nut and the cable packing in this order.
(See the following figure for the direction.)

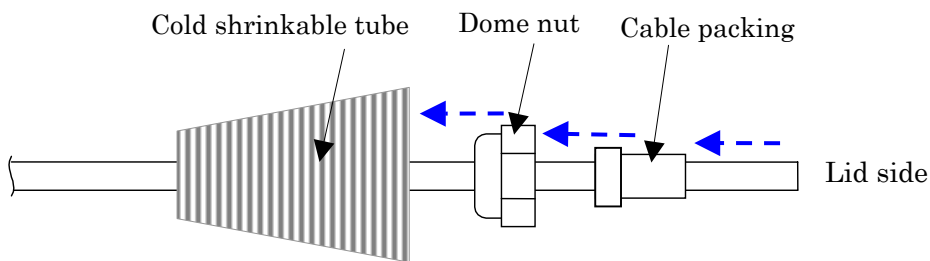

Peel the sheath off the GPI control cable to expose the conductor.

→Peeling length of the sheath: 10 to 15 cm

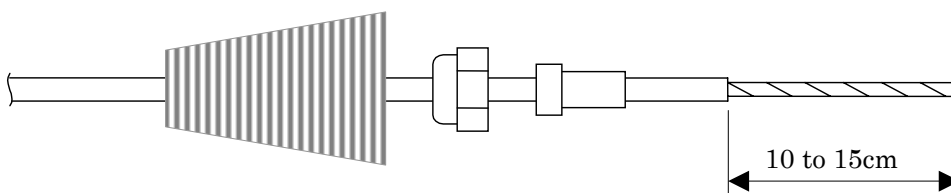

Loosen the copper shield and coil it around the conductor at the shield root part by more than 4 turns.

For the GPI control cable, 3 pairs of twisted-pair cables are used.

If there are 4 pairs of cables, coil the cable with a tape to prevent the extra one pair from short circuit.

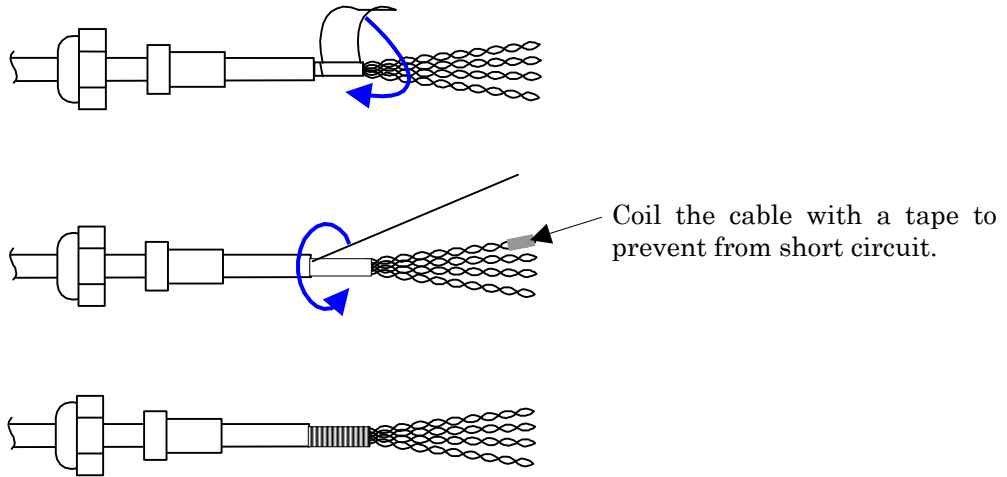

3) Removing the surge box cover for the GPI cable

Loosen 2 fixing screws and remove the surge box cover for the GPI cable.

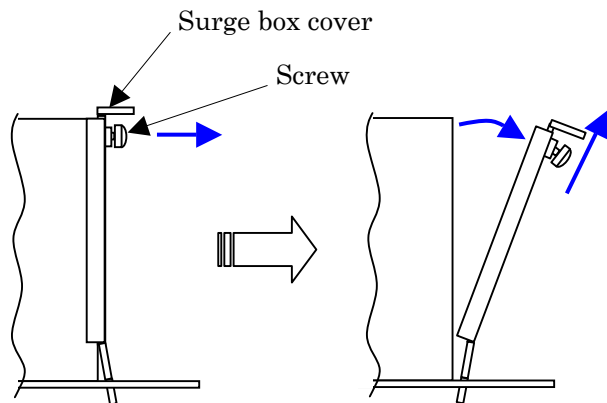
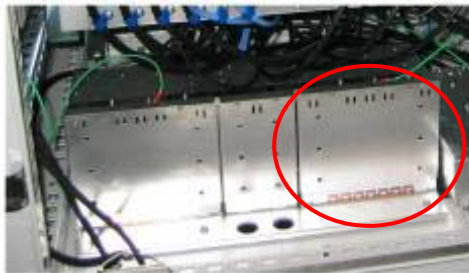

4) Removing the cable clamp for the GPI cable

Remove 2 screws fixing the cable clamp for the GPI cable and then remove the cable clamp.

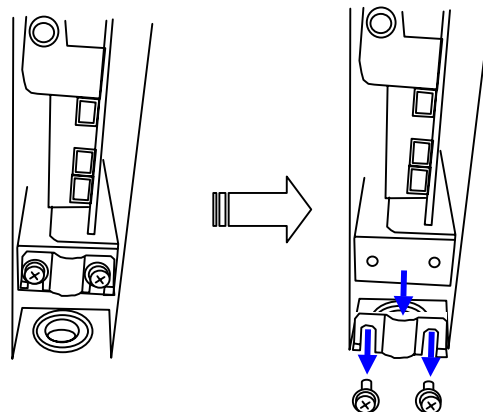

- 5) Inserting the GPI cable
 Insert the GPI cable through the bushing into the Base Unit.

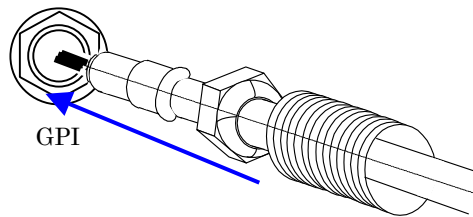

- 6) Fixing the cable clamp for the GPI cable
 Adjust the cable clamp to the copper shield and fix the screws so as to make no space between the copper shield and the cable clamp.
 →Tightening torque: 1.5N·m

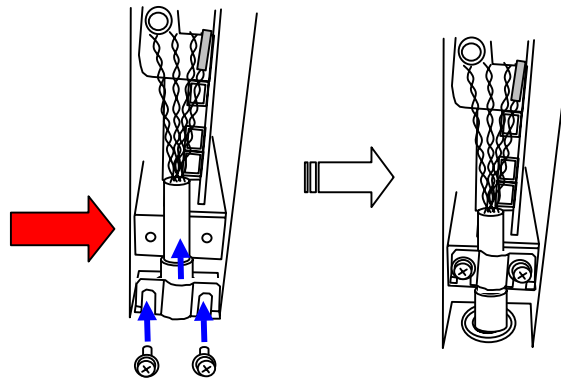

- 7) Press-connecting 232D connector
 Unstitch the conductor (3 pairs = 6 conductors) and connect them to the specified crimping connector.
 For the assignment of inserting conductor's 1pin and 2pin to the connector, refer to the following figure.
 Press the connector while inserting the conductors to the far end.
 Recommended connector: Press-contact connector manufactured by DDK (DDK Ltd.)
 Product No: 232D-02S1B-DA2

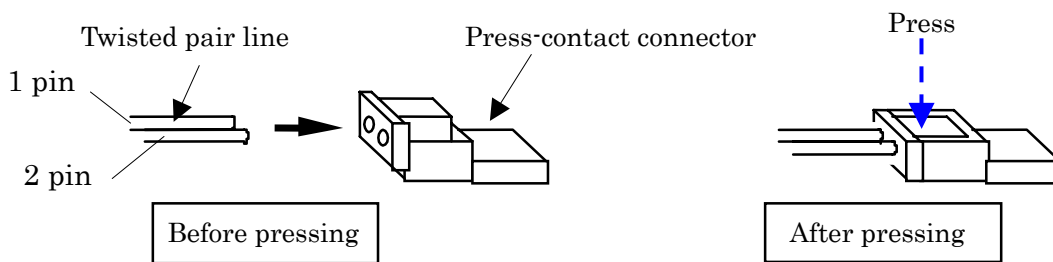

GND	2 pin	Blue / spiral
GPI2	1 pin	Blue
GND	2 pin	Green / spiral
GPI1	1 pin	Green
GND	2 pin	Orange / spiral
GPI0	1 pin	Orange

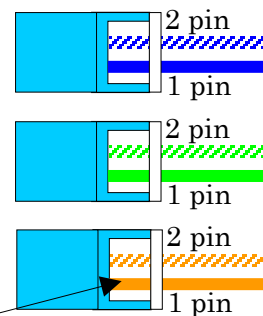

Press connector while the conductors are inserted to the far end.

- 8) Connecting the press-contact connector to the surge board
Insert the press-contacted connector to the (232D) connector on the surge board.

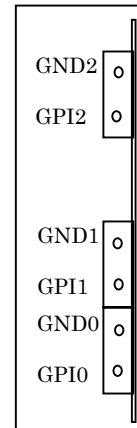
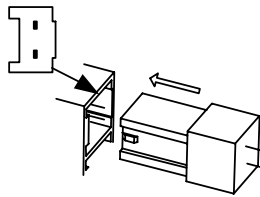

- 9) Forming the conductor
Form the conductor not to extend over the surge box.



- 10) Tightening the dome nut
After inserting the cable packing, tighten the dome nut by hand and then retighten it using a torque wrench.
→Tightening torque: 2.45N·m

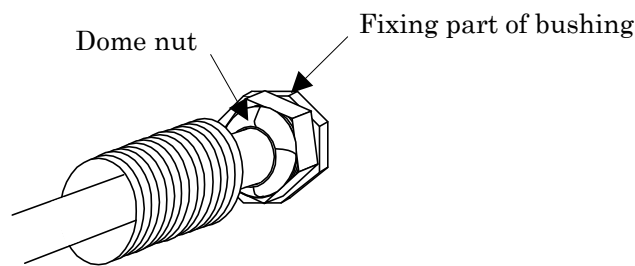

- 11) Waterproof treatment for the GPI cable
Cover the cold shrinkable tube over the root of the connector and shrink it.

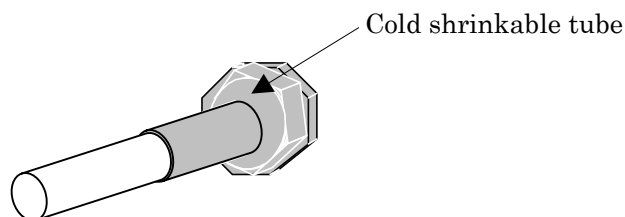

12) Mounting the surge box cover

Mount the surge box cover and tighten the surge box cover fixing screw with a specified torque.

→ Tightening torque: 1.5 N·m

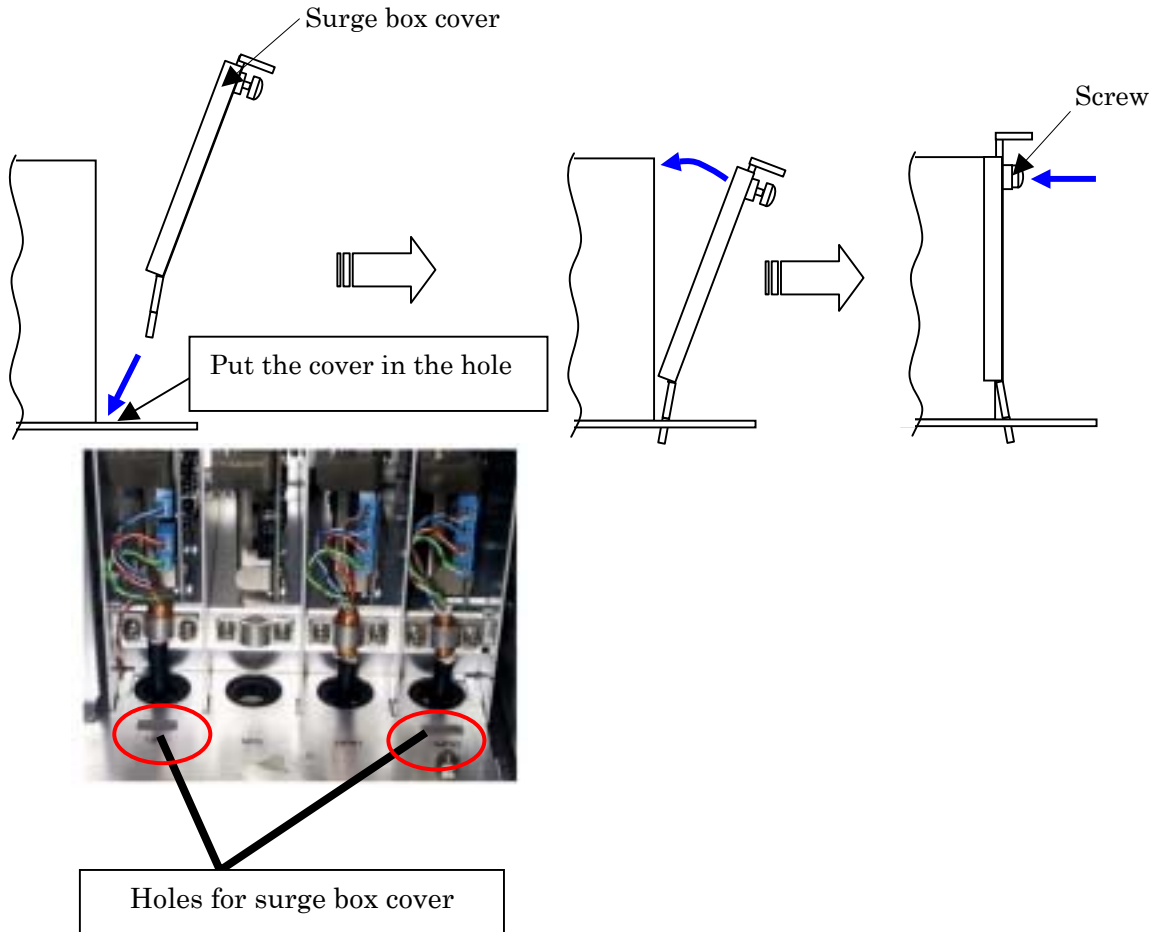

3.4.3.8 Connecting the Master/Slave cable

3.4.3.8.1 Master Base Unit

1) Removing the dome nut for the Master/Slave cable

Remove the dome nut for the Master/Slave cable at the bottom of the Base Unit and remove the cable packing.

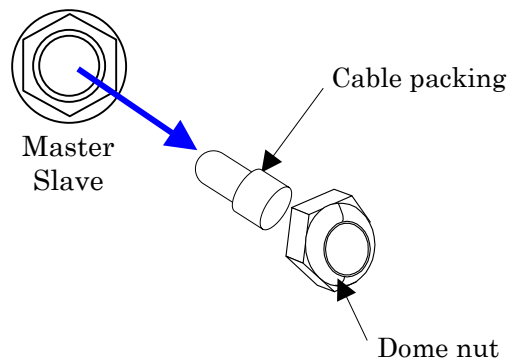

2) Pre-finishing the Master/Slave cable

Put the Master/Slave cable through the cold shrinkable tube, the dome nut and the cable packing in this order.

(See the following figure for the direction.)

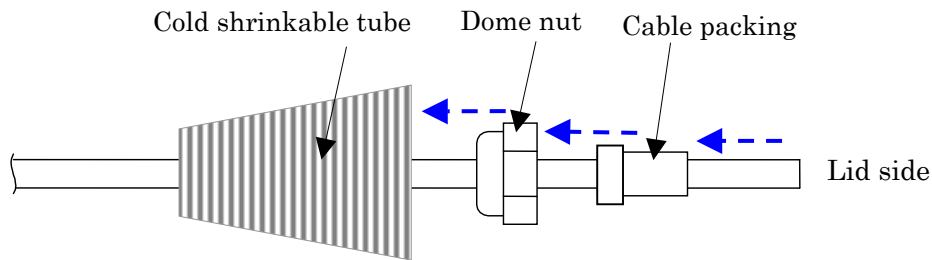

Peel the sheath off the Master/Slave control cable to expose the conductor.

→Peeling length of the sheath: 10 to 15 cm

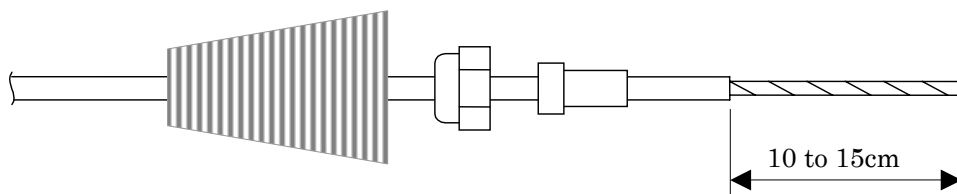

Loosen the copper shield and coil it around the conductor at the shield root part by more than 4 turns.

For the Master/Slave control cable, 2 pairs of twisted-pair cables are used.

If there are 4 pairs of cables, coil the cable with a tape to prevent the extra two pairs from short circuit.

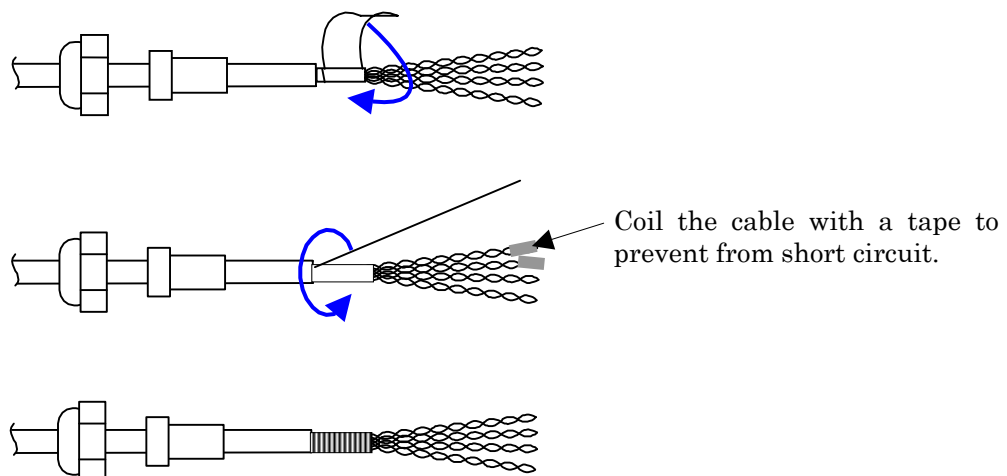

- 3) Removing the surge box cover for the Master/Slave cable
Loosen 2 fixing screws and remove the surge box cover for the Master/Slave cable.

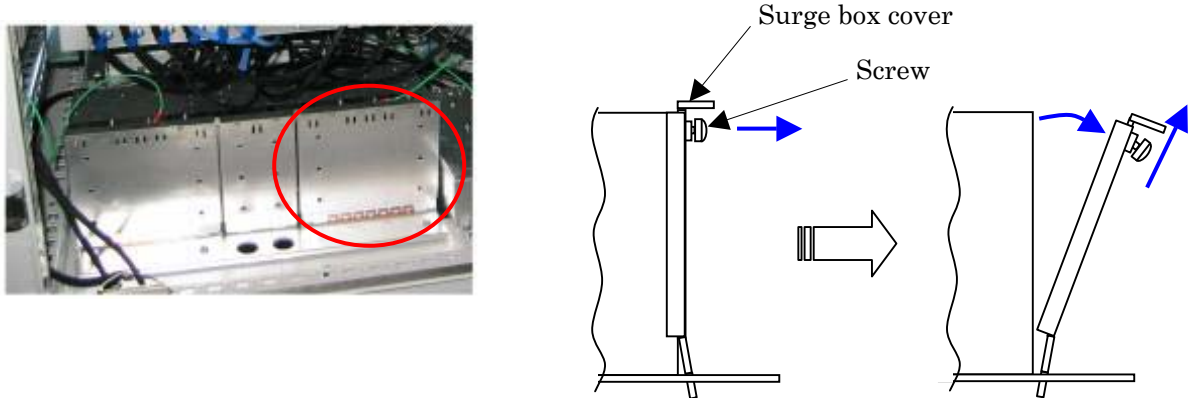

- 4) Removing the cable clamp for the Master/Slave cable
Remove 2 screws fixing the cable clamp for the Master/Slave cable and then remove the cable clamp.

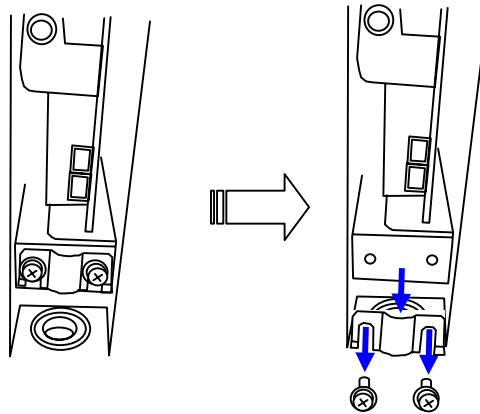

- 5) Inserting the Master/Slave cable
Insert the Master/Slave cable through the bushing into the Base Unit.

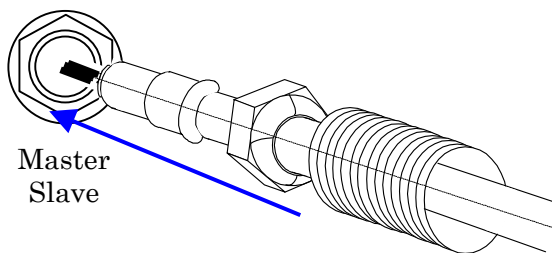

- 6) Fixing the cable clamp for the Master/Slave cable
 Adjust the cable clamp to the copper shield and fix the screws so as to make no space between the copper shield and the cable clamp.
 →Tightening torque: 1.5N·m

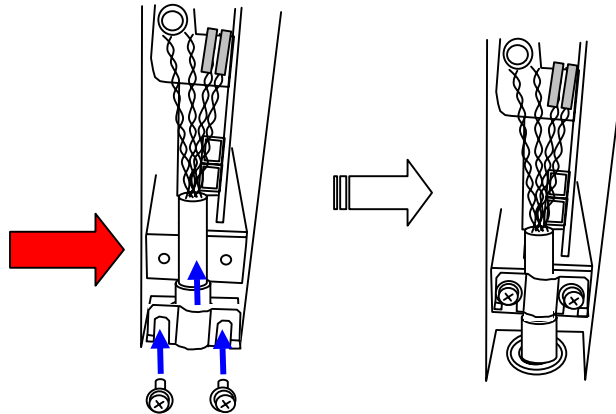

- 7) Press-connecting 232D connector
 Unstitch the conductor (2 pairs = 4 conductors) and connect them to the specified crimping connector.
 For the assignment of inserting conductor's 1pin and 2pin to the connector, refer to the following figure.
 Press the connector while inserting the conductors to the far end.
 Recommended connector: Press-contact connector manufactured by DDK (DDK Ltd.)
 Product No: 232D-02S1B-DA2

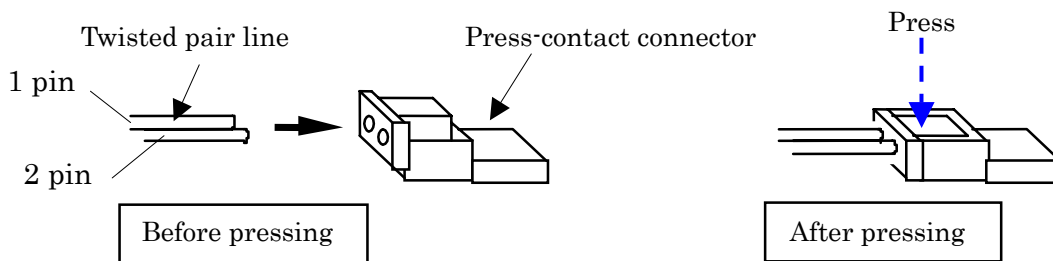

Master Base Unit

Rx -	2 pin	Green / spiral
Rx +	1 pin	Green
Tx -	2 pin	Orange / spiral
Tx +	1 pin	Orange

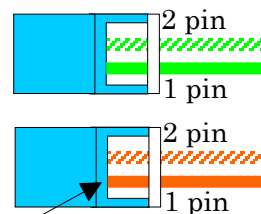

Press connector while the conductors are inserted to the far end.

- 8) Connecting the press-contact connector to the surge board
Insert the press-contacted connector to the (232D) connector on the surge board.

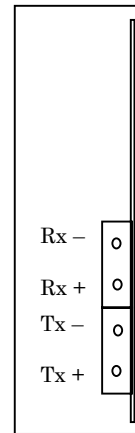
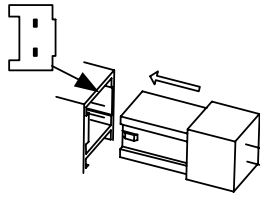

- 9) Forming the conductor
Form the conductor not to extend over the surge box.



- 10) Tightening the dome nut
After inserting the cable packing, tighten the dome nut by hand and then retighten it using a torque wrench.
→Tightening torque: 2.45N·m

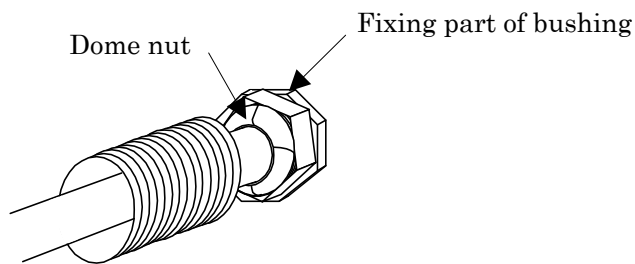

- 11) Waterproof treatment for the Master/Slave cable
Cover the cold shrinkable tube over the root of the connector and shrink it.

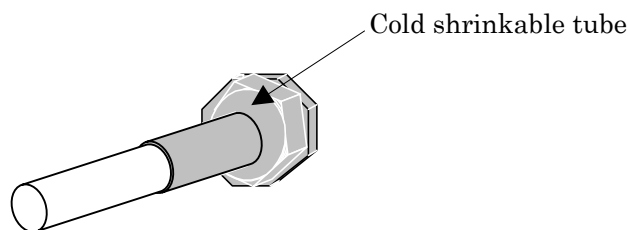

12) Mounting the surge box cover

Mount the surge box cover and tighten the surge box cover fixing screw with a specified torque.

→ Tightening torque: 1.5 N·m

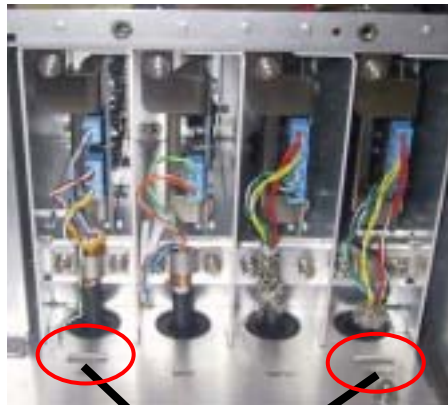
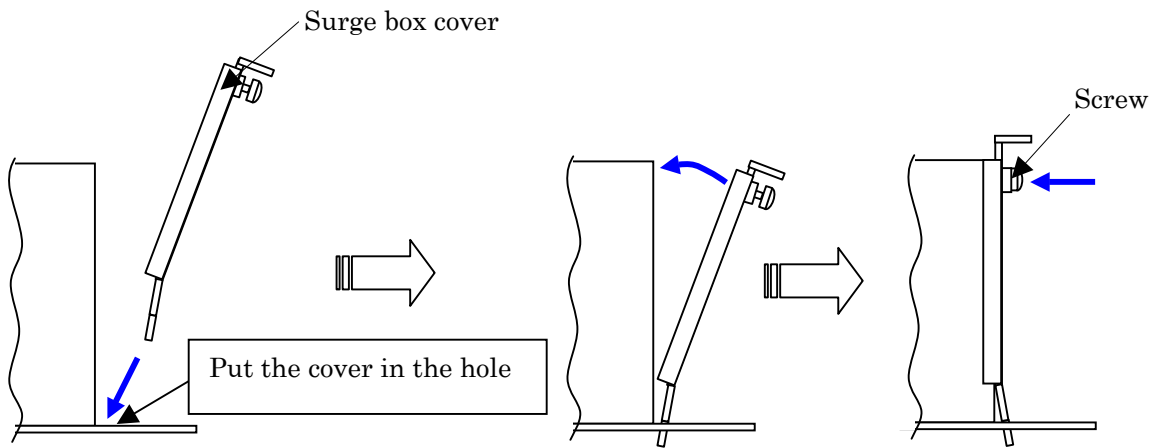

Holes for surge box cover

3.4.3.8.2 Slave Base Unit

The work of 1) to 6), and 10)-12) is omitted for the same work as a Master Base unit, and indicates 7) to 9).

- 1)
 - 2)
 - 3)
 - 4)
 - 5)
 - 6)
- } The same work as a Master Base unit is done.

7) Press-connecting 232D connector

Unstitch the conductor (2 pairs = 4 conductors) and connect them to the specified crimping connector.

For the assignment of inserting conductor's 1pin and 2pin to the connector, refer to the following figure.

Press the connector while inserting the conductors to the far end.

Recommended connector: Press-contact connector manufactured by DDK (DDK Ltd.)

Product No: 232D-02S1B-DA2

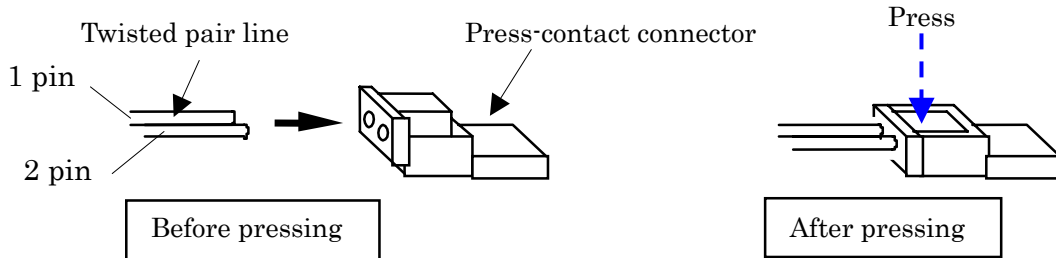

Slave Base Unit

Rx -	2 pin	Orange / spiral
Rx +	1 pin	Orange
Tx -	2 pin	Green / spiral
Tx +	1 pin	Green

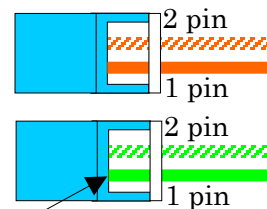

Press connector while the conductors are inserted to the far end.

8) Connecting the press-contact connector to the surge board

Insert the press-contacted connector to the (232D) connector on the surge board.

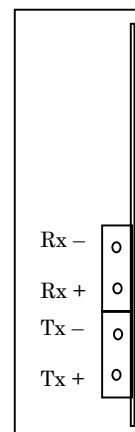
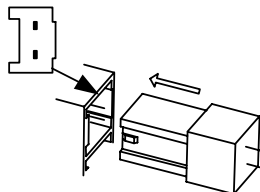

9) Forming the conductor

Form the conductor not to extend over the surge box.



10), 11), and 12) do the same work as a Master Base unit.

3.4.3.9 Attachment of Grounding Kit

According to maker's installation manual, Grounding Kit is attached on a PU-BU RF cable and a Calibration cable. When a Base unit is indoor, it is at an outside of the entrance and in the case of the outdoors, it is near the Base unit.

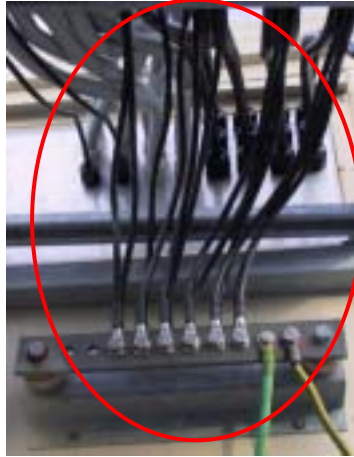

3.4.4 Inserting the board

Make sure what all AC power supply Switch is turn off.

Before touching the board, be sure to take an antistatic measure such as wearing a wristband for preventing static electricity.

Inserting position of the Power supply, the Fan tray and other boards is the following figure.

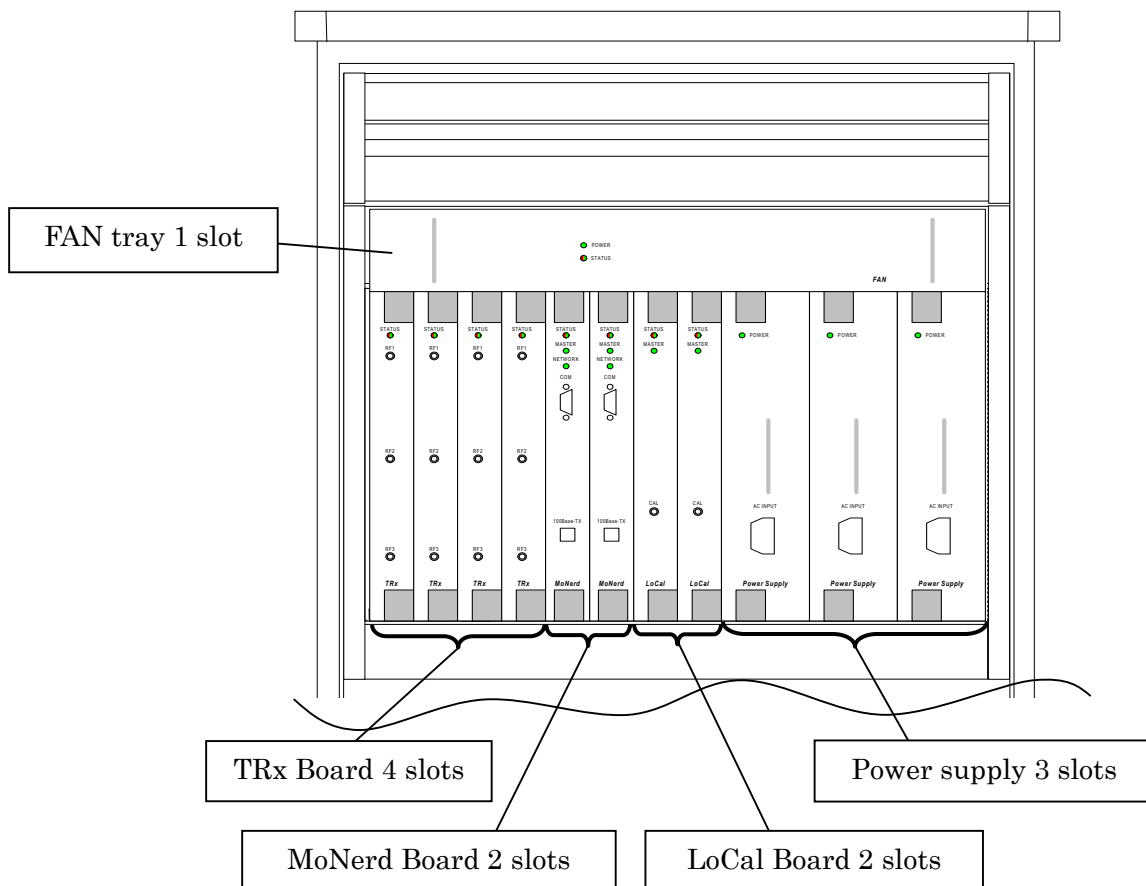

3.4.4.1 Notes at setting Boards and Power supply

3.4.4.1.1 Procedure of board inserting

- 1) Confirm that both upper and lower handles are surely un-locked. If they are in locked condition, press a red "PRESS" button and make it un-locked.

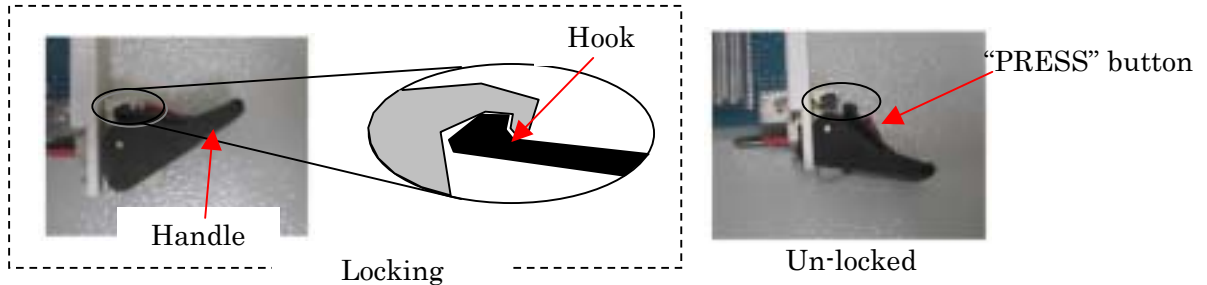

- 2) Insert a board along the board guide while holding cables down so as cables to disturb inserting. Confirm both handles to be un-locked again, then stop inserting the board at when lock part of the board attaches the frame of the Base unit.

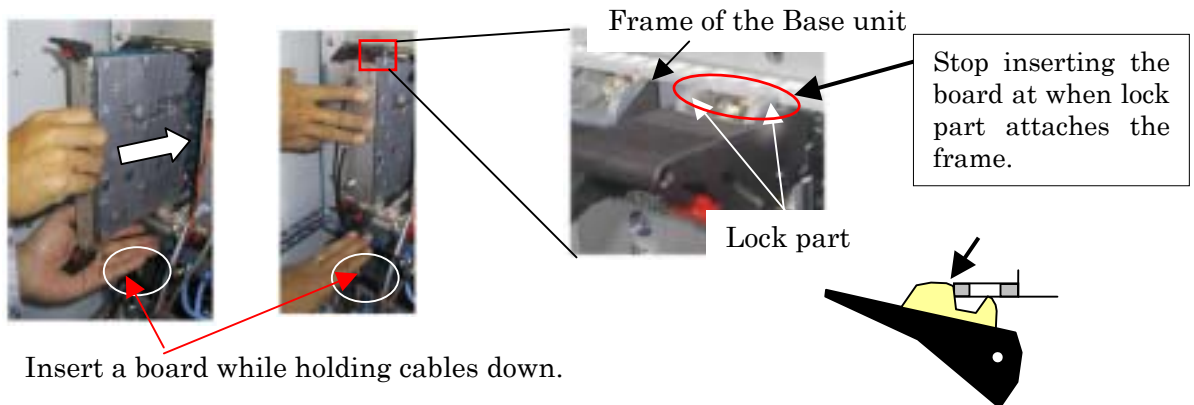

- 3) Lean both upper and lower handle inside at a same time and lock them. Leaning handles inside leads the board getting in automatically and mechanically. If the board does not get in automatically, the lock part may not lock on adequately. Therefore stop leaning handle inside by force.

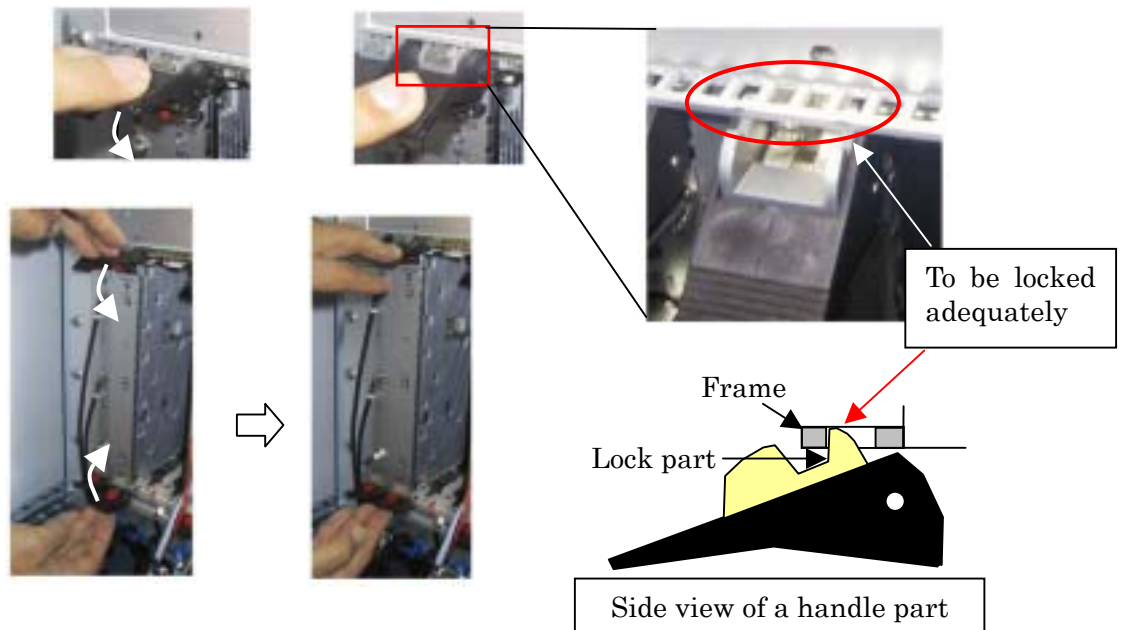

4) Confirmation

Both upper and lower hooks must be securely locked.

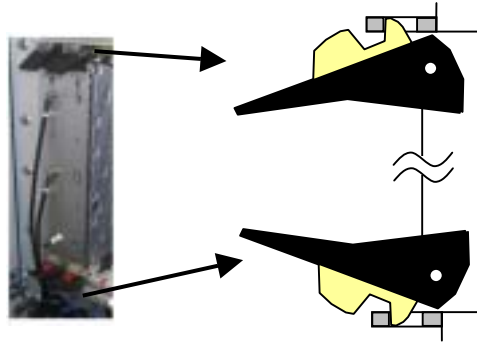

3.4.4.1.2 Prohibitionary work

Never insert a board by pressing itself.

It damages a hook and a sensor damage. A sensor is attached on a lower handle.



A sensor is at this point of a lower handle.



3.4.4.1.3 Handling if miss-inserting

In case of inserting a board or a power supply in a condition that a handle is locked by mistake and giving a stress to the frame.

Un-locking the miss-locked handle by force damages a lock part and a sensor part. Therefore pull the miss-locked handle side as it is.

Example

An upper handle locks adequately

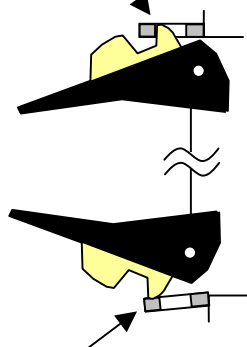

A lower handle miss-locks and gives a stress to the frame.

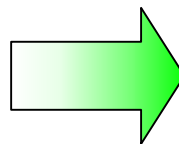

Un-lock the handle.

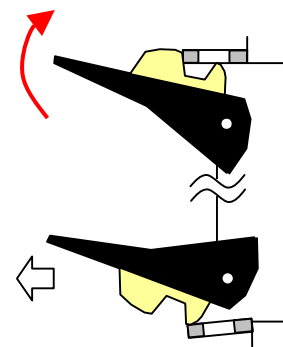

Don't un-lock handle and pull it as it is.

3.4.4.2 Inserting the Power supply

- 1) Insert the Power supply along the both upper and lower guide rail at the determined position so that the bezel character can be read correctly.

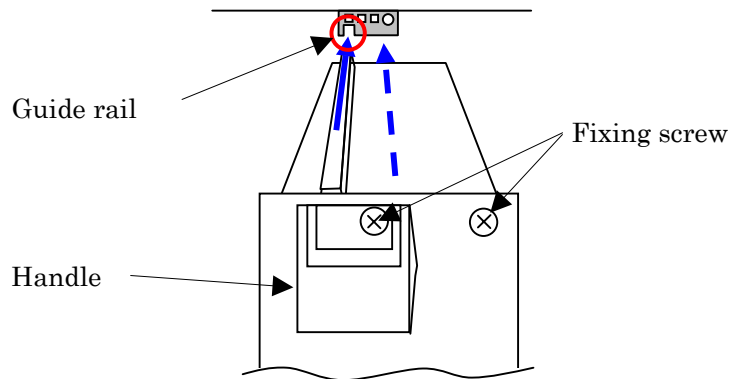

- 2) Turn the upper and lower handles inside and lock them. The handles should be set firmly.
- 3) Tighten the 4 fixing screws
→ Tightening torque: 0.4N·m

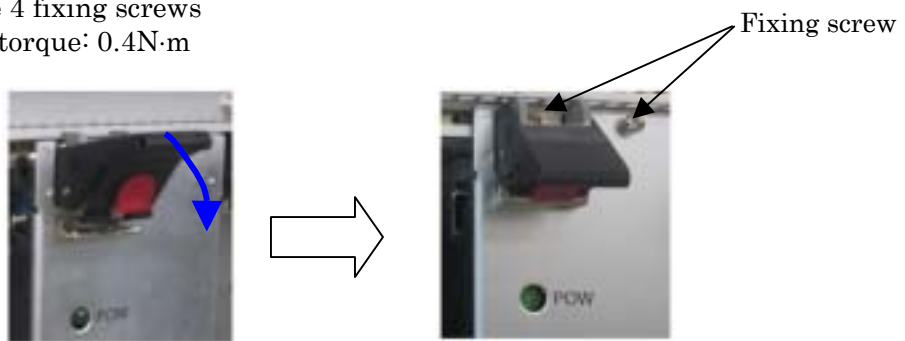

3.4.4.3 Inserting the LoCal board

- 1) Insert the LoCal board along the both upper and lower guide rail at the determined position so that the bezel character can be read correctly as same work as of the Power supply.

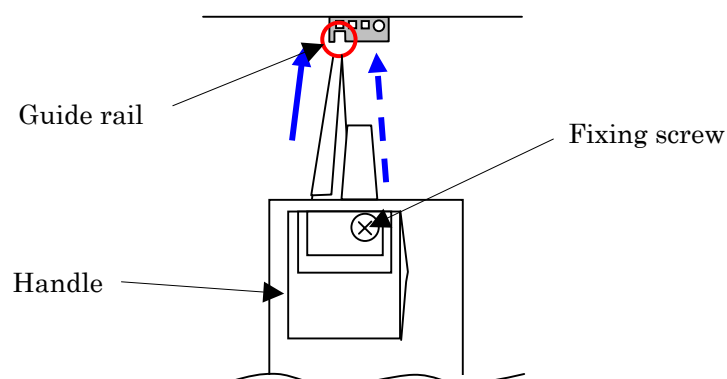

- 2) Turn the upper and lower handles inside and lock them. The handles should be set firmly as same work as of Power supply.
- 3) Tighten the 2 fixing screws
→ Tightening torque: 0.4N·m

3.4.4.4 Inserting the MoNerd board

- 1) Insert the MoNerd board along the both upper and lower guide rail at the determined position so that the bezel character can be read correctly as same work as of the Power supply.
- 2) Turn the upper and lower handles inside and lock them. The handles should be set firmly as same work as of the Power supply.
- 3) Tighten the 2 fixing screws
→ Tightening torque: 0.4N·m

3.4.4.5 Inserting the TRx board

- 1) Insert the TRx board along the both upper and lower guide rail at the determined position so that the bezel character can be read correctly as same work as of the Power supply.
- 2) Turn the upper and lower handles inside and lock them. The handles should be set firmly as same work as of the Power supply.
- 3) Tighten the 2 fixing screws
→ Tightening torque: 0.4N·m

3.4.4.6 Inserting the FAN tray

- 1) Insert the FAN Tray along the guide rail at the determined position so that the bezel character can be read correctly.

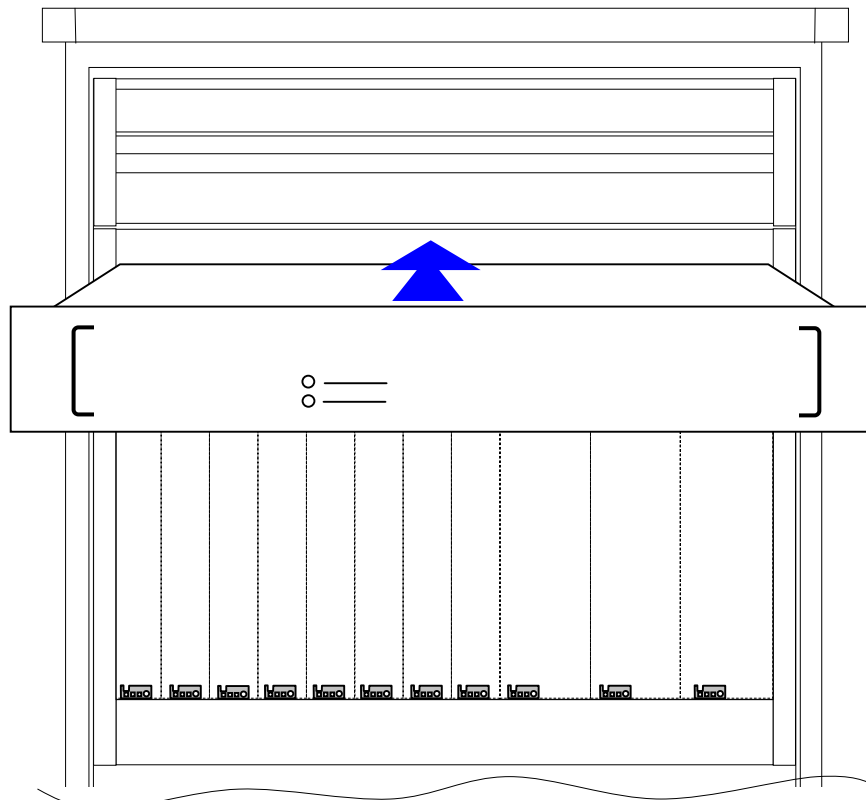

- 2) Tighten the 6 fixing screws
→ Tightening torque: 0.4N·m

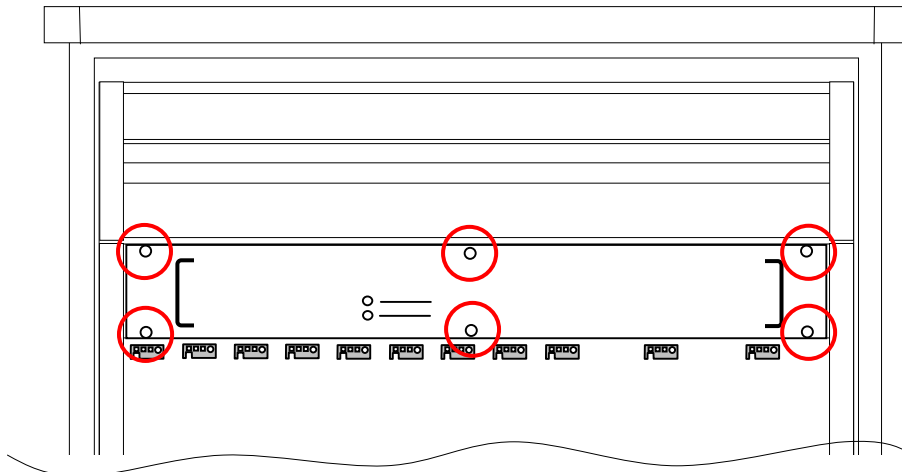

3.4.4.7 Removing the Power supply and other boards

- 1) Loosen upper and lower fixing screws.

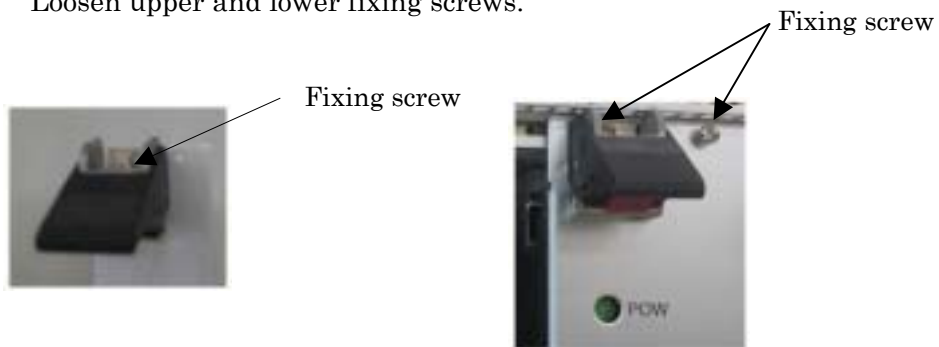

- 2) Press the red "PRESS" part of both handles and release locking.
- 3) Turn the upper and lower handles outside and release connecting.

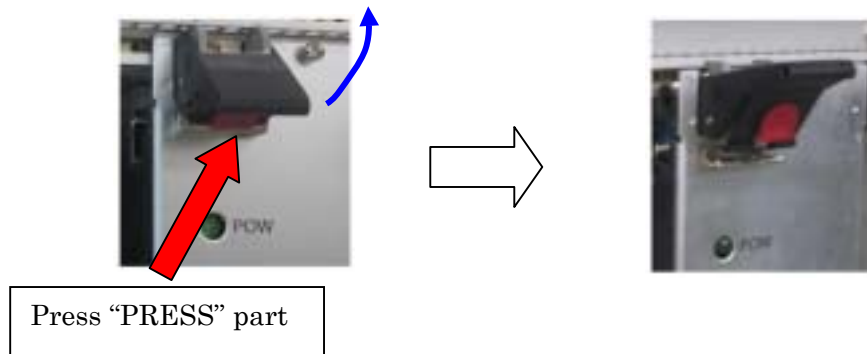

3.4.5 Connecting cables to the Power supply and boards

3.4.5.1 Power supply

- 1) Insert the power supply cable to the Power supply.
There are 3 power supply cables. It is not regulated that any of the power supply cable connects any of the Power supply.

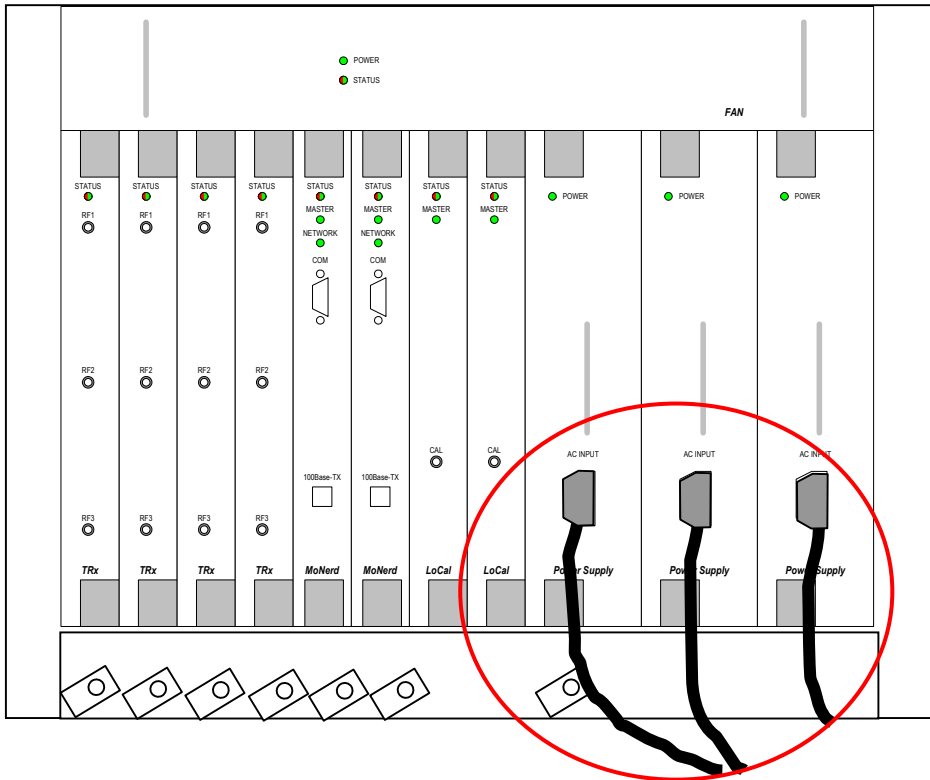

- 2) Lock the power supply cable with the lock.



Power supply cable lock

3.4.5.2 LoCal board

Insert the cable to LoCal board along the label on the cable.

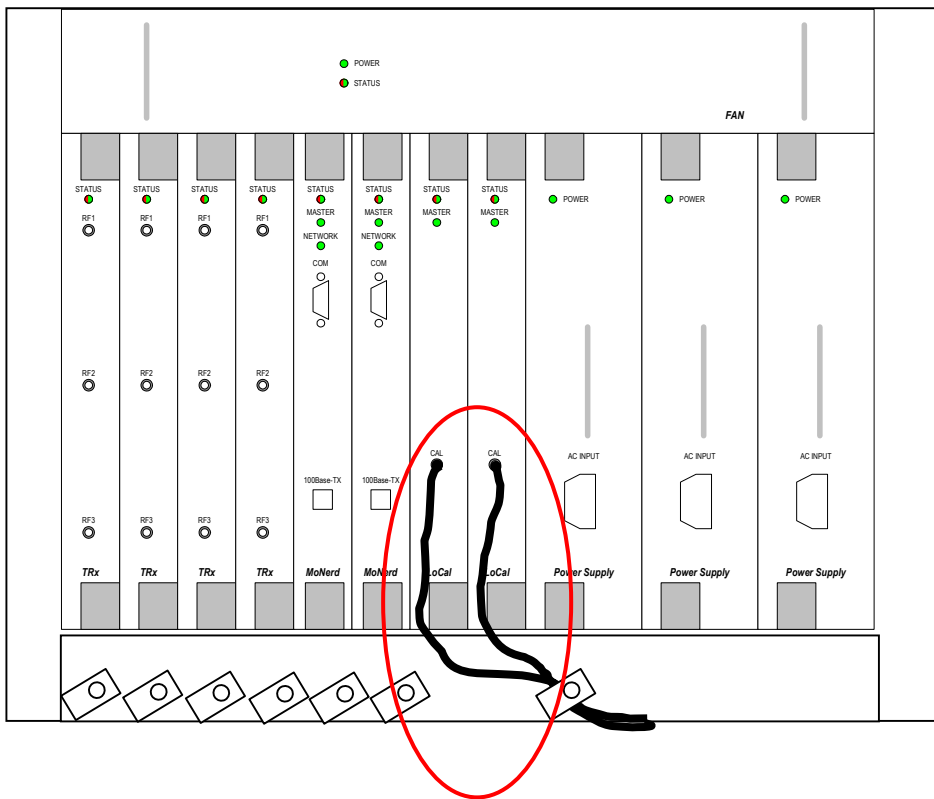

3.4.5.3 MoNerd board

Insert the cable to MoNerd board along the label on the cable.

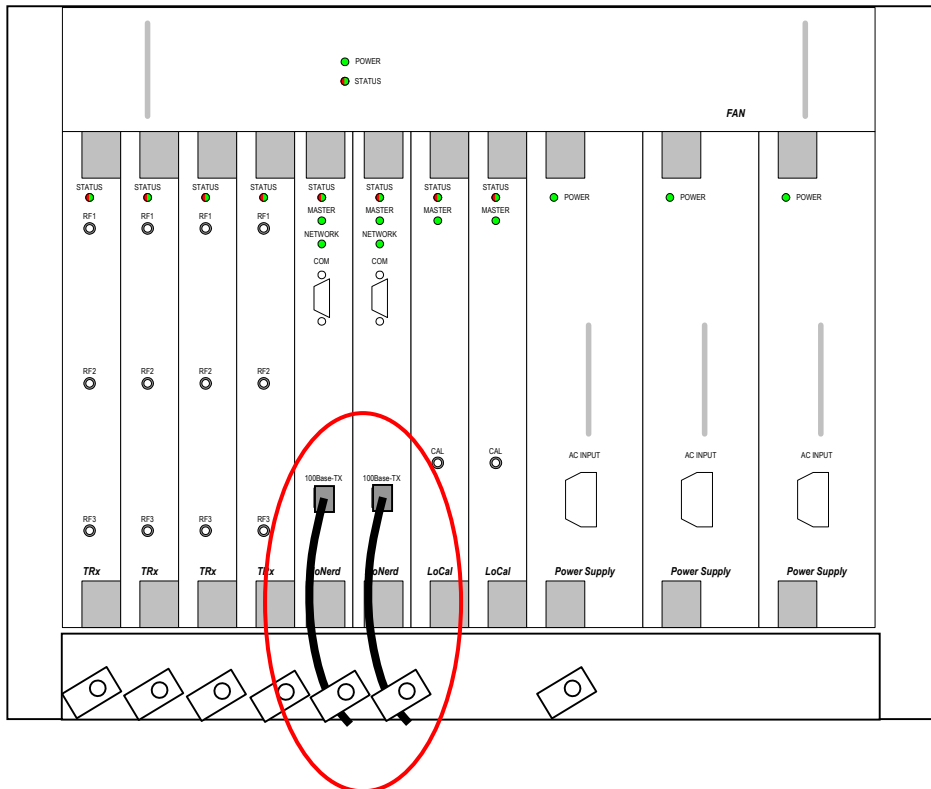

3.4.5.4 TRx the board

Insert the cable to TRx board along the label on the cable.

