

User Guide

Kyocera

Model KX2

The Software features of this handset are subject to modifications and may have changed since the printing of this document.

Draft Copy

82-K5770-1EN, Rev. X5



User Guide for the Kyocera Koi Phone

This manual is based on the production version of the Kyocera Koi phone. Software changes may have occurred after this printing. Kyocera reserves the right to make changes in technical and product specifications without prior notice. The products and equipment described in this documentation are manufactured under license from QUALCOMM Incorporated under one or more of the following U.S. patents:

4,901,307 5,056,109 5,099,204 5,101,501 5,103,459
5,107,225 5,109,390 5,193,094 5,228,054 5,257,283
5,265,119 5,267,261 5,267,262 5,280,472 5,283,536
5,289,527 5,307,405 5,309,474 5,337,338 5,339,046
5,341,456 5,383,219 5,392,287 5,396,516 D356,560
5,408,697 5,414,728 5,414,796 5,416,797 5,426,392
5,437,055 D361,065 5,442,322 5,442,627 5,452,453
5,461,639 5,469,115 5,469,471 5,471,497 5,475,870
5,479,475 5,483,696 5,485,486 5,487,175 5,490,165
5,497,395 5,499,280 5,504,773 5,506,865 5,509,015
5,509,035 5,511,067 5,511,073 5,513,176 5,515,177
5,517,323 5,519,761 5,528,593 5,530,928 5,533,011
5,535,239 5,539,531 5,544,196 5,544,223 5,546,459
5,548,812 5,559,881 5,559,865 5,561,618 5,564,083
5,566,000 5,566,206 5,566,357 5,568,483 5,574,773
5,574,987 D375,740 5,576,662 5,577,022 5,577,265
D375,937 5,588,043 D376,804 5,589,756 5,590,069
5,590,406 5,590,408 5,592,548 5,594,718 5,596,570
5,600,754 5,602,834 5,602,833 5,603,096 5,604,459
5,604,730 5,608,722 5,614,806 5,617,060 5,621,752
5,621,784 5,621,853 5,625,876 5,627,857 5,629,955
5,629,975 5,638,412 5,640,414 5,642,398 5,644,591
5,644,596 5,646,991 5,652,814 5,654,979 5,655,220
5,657,420 5,659,569 5,663,807 5,666,122 5,673,259
5,675,581 5,675,644 5,680,395 5,687,229 D386,186
5,689,557 5,691,974 5,692,006 5,696,468 5,697,055
5,703,902 5,704,001 5,708,448 5,710,521 5,710,758
5,710,768 5,710,784 5,715,236 5,715,526 5,722,044
5,722,053 5,722,061 5,722,063 5,724,385 5,727,123
5,729,540 5,732,134 5,732,341 5,734,716 5,737,687
5,737,700 5,742,734 D393,856 5,748,104 5,751,725
5,751,761 5,751,901 5,754,533 5,754,542 5,754,733
5,757,767 5,757,858 5,758,266 5,761,204 5,764,687
5,774,496 5,777,990 5,778,024 5,778,338 5,781,543
5,781,556 5,781,867 5,784,406 5,784,532 5,790,589
5,790,632 5,793,338 5,797,110 5,799,005 5,799,254
5,802,105 5,805,648 5,805,843 5,812,036 5,812,094
5,812,097 5,812,538 5,812,607 5,812,651 5,812,938
5,818,871 5,822,318 5,825,253 5,828,348 5,828,661
5,835,065 5,835,847 5,839,052 5,841,806 5,842,124
5,844,784 5,844,885 5,844,899 5,844,985 5,848,063

5,848,099 5,850,612 5,852,421 5,854,565 5,854,786
5,857,147 5,859,612 5,859,838 5,859,840 5,861,844
5,862,471 5,862,474 5,864,766 5,864,763 5,867,527
5,867,763 5,870,427 5,870,431 5,870,674 5,872,481
5,872,774 5,872,775 5,872,823 5,877,942 5,878,036
5,870,631 5,881,053 5,881,368 5,884,157 5,884,193
5,884,196 5,892,178 5,892,758 5,892,774 5,892,816
5,892,916 5,893,035 D407,701 5,898,920 5,903,554
5,903,862 D409,561 5,907,167 5,909,434 5,910,752
5,911,128 5,912,882 D410,893 5,914,950 5,915,235
5,917,708 5,917,811 5,917,812 5,917,837 5,920,284
D411,823 5,923,650 5,923,705 5,926,143 5,926,470
5,926,500 5,926,786 5,930,230 5,930,692
Other patents pending.

Kyocera is a registered trademark of Kyocera Corporation. Doodler, and Race 21 are trademarks of Kyocera Wireless Corp. Tetris is a registered trademark of Elorg Company LLC. QUALCOMM is a registered trademark of QUALCOMM, Inc. Openwave is a trademark of Openwave Systems Incorporated. eZiText is a registered trademark of Zi Corporation. All other trademarks are the property of their respective owners.

Copyright © 2003 Kyocera Wireless Corp. All rights reserved.

Ringer Tones Copyright © 2000-2002 Kyocera Wireless Corp.

82-K5570-1EN, Rev X5

FCC/IC Notice

This device complies with part 15 of the FCC rules. Operation is subject to the following two conditions:

- (1) This device may not cause harmful interference, and
- (2) this device must accept any interference received, including interference that may cause undesired operation. To maintain compliance with FCC RF exposure guidelines, if you wear a headset on your body, use the Kyocera Wireless Corp. (KWC) supplied and approved case CA90-61296-01 and holster CV90-L8010-01.

Other accessories used with this device for body-worn operations must not contain any metallic components and must provide at least 25 mm

separation distance including the antenna and the user's body.

THIS MODEL PHONE MEETS THE GOVERNMENT'S REQUIREMENTS FOR EXPOSURE TO RADIO WAVES.

Your wireless phone is a radio transmitter and receiver. It is designed and manufactured not to exceed the emission limits for exposure to radio frequency (RF) energy set by the Federal Communications Commission of the U.S. Government. These limits are part of comprehensive guidelines and establish permitted levels of RF energy for the general population. The guidelines are based on standards that were developed by independent scientific organizations through periodic and thorough evaluation of scientific studies. The standards include a substantial safety margin designed to assure the safety of all persons, regardless of age and health.

The exposure standard for wireless mobile phones employs a unit of measurement known as the Specific Absorption Rate, or SAR. The SAR limit set by the FCC is 1.6 W/kg.* Tests for SAR are conducted using standard operating positions specified by the FCC with the phone transmitting at its highest certified power level in all tested frequency bands.

Although the SAR is determined at the highest certified power level, the actual SAR level of the phone while operating can be well below the maximum value. This is because the phone is designed to operate at multiple power levels so as to use only the power required to reach the network. In general, the closer you are to a wireless base station antenna, the lower the power output.

Before a phone model is available for sale to the public, it must be tested and certified to the FCC that it does not exceed the limit established by the government-adopted requirement for safe exposure. The tests are performed in positions and locations (e.g., at the ear and worn on the body) as required

by the FCC for each model. The highest SAR values for this model phone are:

AMPS mode – Head: 1.32 mW/g; Body-worn: 0.608 mW/g

PCS mode – Head: 0.85 mW/g; Body-worn: 0.310 mW/g.

(Body-worn measurements differ among phone models, depending upon availability of accessories and FCC requirements. The body-worn SAR values provided above were obtained by using Kyocera Wireless Corp. [KWC] supplied and approved case CV90-61296-01 and holster CV90-L8010-01.

While there may be differences between the SAR levels of various phones and at various positions, they all meet the government requirement for safe exposure.

The FCC has granted an Equipment Authorization for this model phone with all reported SAR levels evaluated as in compliance with the FCC RF emission guidelines. SAR information on this model phone is on file with the FCC and can be found under the Display Grant section <http://www.fcc.gov/oet/fccid> after searching on the FCC ID: OVFKWC-KX2.

Additional information on SAR can be found on the Cellular Telecommunications and Internet Association (CTIA) web-site at <http://www.wow-com.com>.

* In the United States and Canada, the SAR limit for mobile phones used by the public is 1.6 watts/kg (W/kg) averaged over one gram of tissue. The standard incorporates a substantial margin of safety to give additional protection for the public and to account for any variations in measurements.

Caution

The user is cautioned that changes or modifications not expressly approved by the party responsible for compliance could void the warranty and user's authority to operate the equipment.

Optimize your phone's performance

Use the guidelines on page 2 to learn how to optimize the performance and life of your phone and battery.

Air bags

If you have an air bag, DO NOT place installed or portable phone equipment or other objects over the air bag or in the air bag deployment area. If equipment is not properly installed, you and your passengers risk serious injury.

Medical devices

Pacemakers—Warning to pacemaker wearers: Wireless phones, when in the 'on' position, have been shown to interfere with pacemakers. The phone should be kept at least six (6) inches away from the pacemaker to reduce risk.

The Health Industry Manufacturers Association and the wireless technology research community recommend that you follow these guidelines to minimize the potential for interference.

- Always keep the phone at least six inches (15 centimeters) away from your pacemaker when the phone is turned on.
- Do not carry your phone near your heart.
- Use the ear opposite the pacemaker.
- If you have any reason to suspect that interference is taking place, turn off your phone immediately.

Hearing aids—Some digital wireless phones may interfere with hearing aids. In the event of such interference, you may want to consult your service provider or call the customer service line to discuss alternatives.

Other medical devices—If you use any other personal medical device, consult the manufacturer of the device to determine if it is adequately shielded from external RF energy. Your physician may be able to help you obtain this information.

In health care facilities—Turn your phone off in health care facilities when instructed. Hospitals and health care facilities may be using equipment that is sensitive to external RF energy.

Potentially unsafe areas

Posted facilities—Turn your phone off in any facility when posted notices require you to do so.

Aircraft—FCC regulations prohibit using your phone on a plane that is in the air. Turn your phone off or switch it to Airplane Mode (page 14) before boarding aircraft.

Vehicles—RF signals may affect improperly installed or inadequately shielded electronic systems in motor vehicles. Check with the manufacturer of the device to determine if it is adequately shielded from external RF energy. Your physician may be able to help you obtain this information.

Blasting areas—Turn off your phone where blasting is in progress. Observe restrictions, and follow any regulations or rules.

Potentially explosive atmospheres—Turn off your phone when you are in any area with a potentially explosive atmosphere. Obey all signs and instructions. Sparks in such areas could cause an explosion or fire, resulting in bodily injury or death. Areas with a potentially explosive atmosphere are often, but not always, clearly marked. They include:

- fueling areas such as gas stations
- below deck on boats
- transfer or storage facilities for fuel or chemicals
- vehicles using liquefied petroleum gas, such as propane or butane
- areas where the air contains chemicals or particles such as grain, dust, or metal powders
- any other area where you would normally be advised to turn off your vehicle engine

Use with care

Use only in normal position (to ear). Avoid dropping, hitting, bending, or sitting on the phone.

Keep phone dry

If the phone gets wet, turn the power off immediately and contact your dealer. Water damage may not be covered under warranty.

Resetting the phone

If the screen seems frozen and the keypad does not respond to keypresses, reset the phone by completing the following steps:

1. Remove the battery door.
2. Remove and replace the battery.

If the problem persists, return the phone to the dealer for service.

Accessories

Use only Kyocera-approved accessories with Kyocera phones. Use of any unauthorized accessories may be dangerous and will invalidate the phone warranty if said accessories cause damage or a defect to the phone.

To shop online for phone accessories, visit www.kyocera-wireless.com/store.

To order by phone, call (800) 349-4188 (U.S.A. only) or (858) 882-1410.

Radio Frequency (RF) energy

Your telephone is a radio transmitter and receiver. When it is on, it receives and sends out RF energy. Your service provider's network controls the power of the RF signal. This power level can range from 0.006 to 0.6 watts.

In August 1996, the U.S. Federal Communications Commission (FCC) adopted RF exposure guidelines with safety levels for hand-held wireless phones. These guidelines are consistent with the safety standards previously set by both U.S. and international standards bodies in the following reports:

- ANSI C95.1 (American National Standards Institute, 1992)

- NCRP Report 86 (National Council on Radiation Protection and Measurements, 1986)
- ICNIRP (International Commission on Non-Ionizing Radiation Protection, 1996)

Your phone complies with the standards set by these reports and the FCC guidelines.

E911 Mandates

Where service is available, this handset complies with the Phase I and Phase II E911 Mandates issued by the FCC.

Battery and charger specifications.

Charger	Input	Output
CV90-60858-01	100-240VAC / 50/60Hz	4.5V 1.5A
CV90-60859-01	120VAC / 60Hz	5.2V 400mA
Standard Battery:		
CV90-L6002-01	3.7V / 900mAh	
Extended Battery:		
CV90-L6236-01	3.7V / 1400mAh	



093 453 037

Kyocera Wireless Corp.

10300 Campus Point Drive, San Diego, CA 92121
U.S.A.

Visit us at www.kyocera-wireless.com

To purchase accessories, visit

www.kyocera-wireless.com/store

CONTENTS

1 Getting Started	1	Setting up voice dialing	39
Using the battery	1	Calling using voice tags	39
Getting to know your phone	3	Calling using digit dialing	40
2 Making and Answering Calls	9	Training voice recognition	41
Making a call	9	8 Using the Camera	42
Using the speakerphone	10	Setting up the camera	42
Speed dialing	12	Taking a picture	44
Setting up voicemail	12	Sending a picture	45
Silencing an incoming call	13	Setting up the video camera	47
Calling emergency services	13	Recording a video	48
Understanding roaming	14	Video key map	49
3 Entering Text, Numbers, and Symbols	16	9 Using Media Gallery	50
4 Storing Contacts	19	10 Using Tools	53
Creating a new contact	19	Voice Memo	53
Editing or erasing a contact	19	Scheduler	53
Editing a phone number	20	Alarm Clock	54
Finding contact information	21	Tip Calculator	54
5 Sending and Receiving Text Messages . 22		Calculator	55
Sending text messages	22	Timer	55
Retrieving text messages	25	Stopwatch	55
Customizing message settings	27	11 Fun & Games	56
6 Customizing Your Phone	29	Tetris	56
Silencing all sounds	30	Race 21	56
Choosing ringers	30	My Sounds	58
Setting sounds for your phone	31	My Pictures	58
Adjusting volume	31	12 Connecting to the Internet	60
Setting message alerts	32	Using the Web Browser	60
Using shortcuts	32	13 Getting Help	62
Personalizing the screen	33	Index	63
Creating a secure environment	35		
Network settings	37		
Setting position location	38		
7 Using Voice Recognition	39		

1 GETTING STARTED

Opening and closing Koi

Kyocera's Koi has a swivel function that offers various features when open and closed. These features are detailed throughout this guide.

To open the swivel, face the phone screen toward you and gently slide the swivel to the right and up until it clicks into place.

To close the swivel, push it down and to the right until it clicks into place.

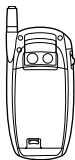

Important: Do not attempt to pull the swivel apart from the base.

Using the battery

Installing the battery

Your phone comes with a removable lithium ion (LiIon) battery. Hold the phone facing away from you.

1. Slide the tab at the bottom of the door up. Remove the battery door.

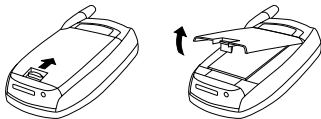

2. Place the battery in the phone casing with the metal contacts facing the right side of the phone.

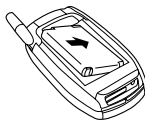

3. Replace the battery door by sliding the notches into the openings near the top of the phone.
4. Lower the battery door and slide the tab at the bottom of the door up and then down to secure the cover into place.

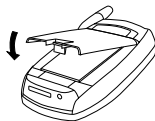



Charging the battery

You must have at least a partial charge in the battery to make or receive calls. **Fully charge the battery before using the phone.**

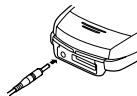
To charge the battery, connect the AC adapter to the jack on the bottom of the phone, then plug the adapter into a wall outlet.



The battery icon in the upper-right corner of the screen tells you whether the phone is:

- Charging (the icon is animated)
- Partially charged 
- Fully charged 

Recharging the battery

You can safely recharge the battery at any time, even if it has a partial charge.

Caring for the battery

General safety guidelines

- Do not take apart, puncture, or short-circuit the battery.
- If you have not used the battery for more than a month, recharge it before using your phone.
- Avoid exposing the battery to extreme temperatures, direct sunlight, or high humidity.
- Never dispose of any battery in or near a fire – it could explode.

Common causes of battery drain

- Playing games or using the Web
- Keeping backlighting on
- Operating in analog (A) mode. Your phone switches between modes to find the best signal. To set your phone to operate in a single mode, select **Menu** → **Settings** → **Network** → **Digital/Analog**.
- Operating in digital mode when far away from a base station or cell site.
- Using data cables or accessories.
- Operating when no service is available, or service is available intermittently.
- High earpiece and ringer volume settings.
- Repeating sound, vibration or lighted alerts.

Accessing shortcuts (swivel open)

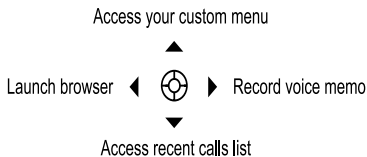

Navigation key shortcuts

From the home screen press the navigation key in one of four directions to access three shortcuts and one custom menu (see page 33 for instructions on setting up your custom menu).



Jog shuttle shortcuts

From the home screen, pressing the jog shuttle activates two shortcuts:

- Press and hold  down to access the recent calls list.
- Press and hold  in to activate voice dialing.

Getting to know your phone

- 1 **Home screen.**
- 2 **OK key** selects a menu item or option.
- 3 **Left Softkey** accesses menus and functions.
- 4 **Speakerphone key** activates the speakerphone.
- 5 **Send/Talk key** starts or answers calls.
- 6 **Keypad** for entering numbers, letters, or symbols.
- 7 *** Shift key** changes the text mode in text entry.
- 8 **Jacks for AC adapter** (included) and **data cable** (sold separately).
Warning: Inserting an accessory into the incorrect jack may damage the phone.
- 9 **Camera key**  to take snapshots and record videos.
- 10 **Navigation key** scrolls through lists and menus and positions cursor during text entry.
- 11 **Right Softkey** to access Contacts and other menu options.
- 12 **User-definable menu key** lets you create a menu that contains your favorite features.
- 13 **End/Power key** turns the phone on and off, ends a call, or returns you to the home screen.
- 14 **Back key** erases characters in text entry or returns you to the previous screen.
- 15 **# Space key** enters a space during text entry. Activates Silent mode.
- 16 **0 Next key** cycles through word choices during text entry.

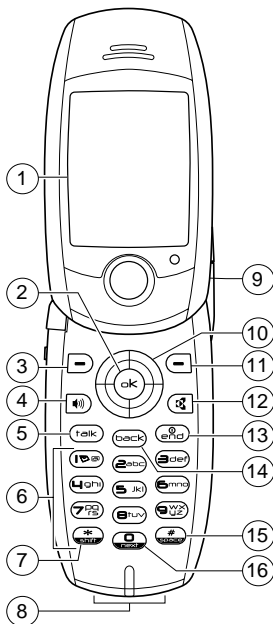

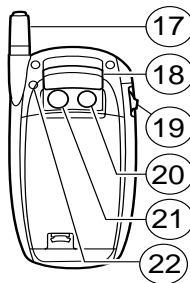

- 17 **Antenna** extends for making and answering calls.
- 18 **Lens cover** for camera flash and lens.
- 19 **Jog shuttle**  for selecting menus and operating the camera while the swivel is closed.
- 20 **Camera lens**
- 21 **Camera flash**
- 22 **Jack** for hands-free headset (sold separately).







Using Menus

Swivel closed

The following menu items are available with the swivel closed by pressing the jog shuttle  in.

Note: Press  down to move between menu items.

- **Silent Mode:** Silences the phone. Press  in twice to activate. The silent mode icon appears at the top of the menu screen.
- **Keyguard:** Locks the jog shuttle. The jog shuttle is temporarily disabled when you open the swivel. It is enabled when swivel is again closed. Press and hold  up to lock and unlock keyguard.

- **Voice Dialing:** Initiates the voice dialing prompt by pressing and holding  in.
- **Call History:** Accesses the last 60 calls from all categories: missed, outgoing, incoming. To return a recent call, highlight the number, and press  in.
- **Contacts:** Accesses your contacts list. Highlight the contact and press  in to call.
- **Camera:** Allows you to choose whether to take a picture, record a video, or view camera pictures or your video album.
- **Scheduler:** Launches the month view of the scheduler menu.
- **Media Gallery:** View or listen to media.

Tip: To return to the home screen from any of these menus, press the camera key .

Swivel open

The following menu items are available to you with the swivel open:

Call History

All Calls
Incoming Calls
Outgoing Calls
Missed Calls
Erase Call Lists
Recent Calls Timer
All Calls Timer
Kilobyte Counter

Contacts

View All
Add New
Find Name
Add Voice Dial
Speed Dial List
Voice Dial List
Business List
Personal List
Information

Messages

New Text Message
New Pix Message
Voicemail
InBox
Net Alerts*
OutBox*
Saved
Drafts
Msg Settings
Group Lists*
Erase Messages

Web Browser

Connects to Internet

Settings

Silent Mode
Sounds
Display
Convenience
Voice Features
Messaging
Security
Network
Accessories

Tools & Games

Tetris®
Race 21™
Voice Memo
Scheduler
Alarm Clock
Tip Calculator
Calculator
Timer
Stopwatch
Doodler™

Phone Info

Phone number,
software, ESN, icons

Camera

Launches the camera







Media Gallery

Camera Pictures
Images
Sounds
Video

*Not available on all phones, check with your service provider.

Accessing menu items (swivel open)

To access menu items from the home screen:

- Press  to select the **Menu** softkey.
- Press  to select the **Contacts** softkey.
- Press  left, right, up, or down to see menus and options. Press  to select a menu item.
- Press  to back up a menu level.
- Press  to return to the home screen.



















In this guide, an arrow → tells you to select an option from a menu. For example, **Menu** → **Settings** means select **Menu**, then select the **Settings** option.

Note: To change the way the menus appear, select **Menu** → **Settings** → **Display** → **Main Menu View**, then select **Wheel**, **Graphic**, or **List** and press . See “Choosing a menu view” on page 33 for details.















Performing basic functions

Swivel closed

Note: The phone must be powered ON to perform the following functions.

















To...	From the home screen...
Make a call	Press and hold  in to initiate voice dialing. Contact must have voice tag assigned (see page 39).
End a call	Press  in.
Adjust volume during call	Press  up or down.
Acknowledge an alert	Press  in when you see the OK softkey.
Access Recent Calls List	Press and hold  down.
Set Silent Mode	Press  in twice.
Set Keyguard	Press and hold  up. To unlock, press and hold  up again.
Take a picture	Open the camera lens cover. Press camera key  .
Record a video	<ol style="list-style-type: none">1. Press  in and scroll to Camera. Press  in again. Press  down and highlight Video Mode. Press  in again.2. Press . Recording continues until you press  a second time.
Access menus	Press  in once.
Scroll menus	Press  up and down.
Select menus	Highlight a menu or option and press  in once.















Swivel open

To...	From the home screen...
Turn the phone on	Press  and wait until the phone beeps.
Turn the phone off	Press and hold  until the phone beeps.
Make a call	Enter the number, and press  .
End a call	Press  .
Answer a call	Press  .
Access voicemail	Press and hold  and follow the system prompts.
Verify your phone number	Select Menu → Phone Info .
Silence the ringer	Press  , then  to answer.
Activate voice dialing	Press  once and follow the prompts (see page 39).
Launch the browser	Press and hold  left.
Record a voice memo	Press and hold  right.
Access recent calls list	Press  down.
Take a picture	Open camera lens cover. Press camera key  .
Record a video	Open camera lens cover. Select Menu → Camera . Select Options . Scroll left or right on the horizontal menu bar using  to select the Video Mode option. Focus on the image and select Record . When finished recording, select Stop .

Understanding screen icons

These icons may appear on your phone's screen.

-  The phone is operating in IS2000 (1X) digital mode.
-  The phone is operating in IS95 digital mode.
-  The phone is operating in Analog (FM) mode.
-  The phone is receiving a signal. You can make and receive calls. Fewer bars indicate a weaker signal.
-  A call is in progress.
-  The phone is not receiving a signal. You cannot make or receive calls.
-  The phone is roaming outside of its home service area.
-  You have a text message.
() indicates the message is urgent.)
-  You have a voice message.
-  You have a voice/text message.
-  The phone is in camera mode.
-  Camera flash mode is ready.
-  Camera timer mode is ready.
-  Camera zoom mode is ready.
-  The phone is in video mode.

-  The battery is fully charged. The more black bars, the greater the charge.
-  The alarm clock is set.
-  The phone is in privacy mode or is accessing a secure Web site.
-  High-speed (3G) data service is available and active on your phone. Check with your service provider for availability.
-  (blinking) The phone is sending high-speed data.
-  (blinking) The phone is receiving high-speed data.
-  High-speed data service is available, but the phone is dormant.
-  The phone is at the home screen. To access the Menu softkey, press .
-  The phone is at the home screen. To access the Contacts softkey, press .
-  The phone is set to light up instead of ring.
-  The phone is set to vibrate or to vibrate and then ring.
-  Position location is set to your service provider and to emergency services.
-  Position location is set to emergency services only.

2 MAKING AND ANSWERING CALLS

Making a call

Make sure you are in an area where a signal can be received. Look for  on the home screen. The more bars you see in this symbol, the clearer the reception. If there are no bars, move to where the reception is better.

When the phone has been idle for a time, it changes to power save mode. When you see “Power Save” on your phone’s screen, press any key to return to normal operating mode.

Swivel open

1. Open the swivel.
2. Enter the phone number.
3. Press .

Swivel closed

You can only use voice dialing to make calls with the swivel closed. Voice dialing requires that a contact be saved with a voice tag. See page 39.

1. Press and hold  in to initiate voice dialing.
2. Say the name of the contact when prompted. The phone places the call.

Ending a call

Swivel open





- Press  or close swivel (if “End with Swivel” is enabled. See page 10).

Swivel closed



- Press  in once.

Redialing a number

Swivel open

- To redial a recent call, press  twice to access your recent calls. Highlight a call, and press .
- To redial the last number called, received, or missed, press  three times. If you see a message prompting you to speak a name, press  two more times.



Swivel closed

- Press and hold  down to launch the recent calls list. Highlight a caller and press  in.

Calling a saved number

If you have already saved a phone number, you can use the Contacts list to find it quickly.



1. Press  or  to select **Contacts**.

2. Scroll down the list to find the contact you want to call.
3. Highlight the name and press  or  to dial the number.

Answering calls

When a call comes in, the phone rings, vibrates, or lights up, and a dancing phone icon appears. The phone number of the caller also appears if it is not restricted. If the number is stored in your Contacts directory, the contact name appears.

To answer with swivel open

- Press  to answer the call
- or-
- Press  to answer the call and turn on the speakerphone.

To answer with swivel closed

- Press  in to select **Answer Call**.

To silence or ignore the call

When an incoming call is received, you can choose to:

- **Silence Ringer** to stop the ringing. Ringer Silenced appears on your phone. You can still answer the call or let the call go to voicemail.
- **Ignore Call** to immediately send the caller to voicemail. Missed Call appears on your screen until the caller leaves a message.

Answering calls using the swivel

You can set the phone to answer immediately when you open the swivel. This feature does not apply to incoming data/fax calls.



1. Select **Menu** → **Settings** → **Convenience** → **Answer with swivel**.
2. Select **Enabled** to set the phone to answer when you open the swivel.
Select **Disabled** to have the phone continue ringing when you open the swivel.

Using the speakerphone



Your Kyocera Koi has a built-in speakerphone that you can use during a call when the swivel is open. This function works only for the current call. Once the call is ended, the speakerphone turns off and earpiece volume returns to normal.

To turn on the speakerphone

You may turn on the speakerphone only during a call.

- During an incoming call alert, press  to answer the call and turn on the speakerphone simultaneously.
- Once the speakerphone is turned on, “ Speaker is ON” displays on the screen.





To turn off the speakerphone

- Press  to turn off the speakerphone. The message “ Speaker is OFF” appears.



Dealing with missed calls

When you have missed a call, “Missed Call” appears on your screen unless the caller leaves a voicemail.

Swivel open

- To clear the screen, press  in or  to select **OK**.
- To view details of the call, press  down to highlight **Missed Calls**, then press  twice.
- To return the call, highlight **Missed Calls**, then press .

Swivel closed

- To clear the screen, press  in to select **OK**.
- To return the call, press  down to highlight **Missed Calls** and then press  in twice.



Setting missed call alerts

You can set an alert to beep every five minutes after you have missed a call.

- Select **Menu** → **Settings** → **Sounds** → **Missed Call Alert** → **Enabled**.
Select **Disabled** to turn off the alert.

Viewing recent call details

Details on the last 60 calls you made, received, or missed are stored in the Call History list and are identified by the following icons:

 Outgoing call  Incoming call

 Missed call (flashing)

Viewing recent calls

1. Select **Menu** → **Call History**.
2. Select a list: **All Calls**, **Incoming Calls**, **Outgoing Calls**, or **Missed Calls**.
3. Select a recent call item.
4. Press  to select **Options**.
 - **Save** adds the phone number to the Contacts list.
 - **Add to** adds the phone number to a saved contact.
 - **Send Msg** sends a text message to the contact.
 - **Send Picture Msg** sends a picture message to the contact.
 - **Prepend** adds an area code to the number if you plan to save the number as a contact.

Note: If the phone number has been classified as “secret,” you must enter your four-digit lock code to view or edit it. For information on the lock code, see “Changing your lock code” on page 35. To classify a phone number as secret, see “Creating a new contact” on page 19.



Calling recent calls

Swivel closed

1. Press and hold  down.
2. Highlight the number you want to call.

3. Press  in.

Swivel open

1. Press  down.
2. Highlight the number you want to call.
3. Press .

Erasing recent calls

1. Select **Menu** → **Call History** → **Erase Call Lists**.
2. Select an option: **All Calls, Incoming Calls, Outgoing Calls, or Missed Calls**.
3. Press  to select **Yes**.

Speed dialing

Speed dialing allows you to quickly dial a stored phone number by entering a one- or two-digit speed dialing location number and pressing .

Note: Before you can use speed dialing, you must save a phone number as a contact and assign a speed dial location to it. Refer to “Creating a new contact” on page 19 to create a new contact, or “Editing or erasing a phone number” on page 20 to add speed dial to an existing contact.

Using speed dialing

To call a contact that has a speed dial location:

- From the home screen, enter the one- or two-digit speed dialing location and press .

1-Touch dialing

1-Touch dialing is the fastest way to speed dial a contact that has a speed dial location.



Note: You must (1) enable 1-Touch dialing on your phone and (2) have a speed dial location assigned to a contact. See “Speed dialing” on this page.

Enabling 1-Touch dialing

1. Select **Menu** → **Settings** → **Convenience** → **1-Touch Dialing** → **Enabled**.
2. Press .



Using 1-Touch dialing

To call a contact that has a speed dial location:

- From the home screen, press and hold the speed dialing number. If it is a two-digit number, press the first digit briefly, then press and hold the second digit. For example, if the speed dialing location is 15, press  briefly, then press and hold .

Setting up voicemail

Before your phone can receive voicemail messages, you must set up a password and record a personal greeting with your service provider. When you have set up your voicemail, all unanswered calls to your phone are automatically transferred to voicemail, even if your phone is in use or turned off.

1. From the home screen, press and hold .
2. Press  at the message.

3. Follow the system prompts to create a password and record a greeting.

Note: If you are having trouble accessing your voicemail, contact your service provider.

Checking voicemail messages

When a voice message is received, your screen displays “New Messages” along with the  symbol at the top of your screen. The symbol flashes if the message is urgent.

If you see “New Messages”

Phone open

1. Press  to select **Call**, which initiates a call to your voicemail number.
2. Follow the prompts to retrieve the message.

To clear the screen without checking messages:

- Press  to select the **Ignore** softkey.

Phone closed

Press  in to call voicemail.



Press  down to ignore.

If you see only the symbol

1. Press and hold  to initiate a call to your voicemail number.
2. Follow the prompts to retrieve the message.

Note: You can set the phone to beep or vibrate every five minutes to remind you that you have voicemail. See “Setting message alerts” on page 32.

Silencing an incoming call

- To silence an incoming call quickly, press . Then press  to answer the call.

This action silences the current call only. The next call will ring as normal.

Adjusting the volume during a call

- To adjust the earpiece volume during a call, press  up or down.

Calling emergency services



Note: Regardless of your 3-digit emergency code (911, 111, 999, 000, etc.), your phone operates as described below.

- Dial your 3-digit emergency code and press .

You can call the code even if your phone is locked or your account is restricted. When you call, your phone enters **Emergency mode**. This enables the emergency service exclusive access to your phone to call you back, if necessary. To make or receive regular calls after dialing the code, you must exit this mode.

To exit Emergency mode

When you have completed the emergency call:

1. Press  to select **Exit**.
2. Press  again to confirm your choice.

Note: To determine who has access to your location, see “Setting position location” on page 38.

Tracking calls

You can track the number and duration of calls made and received on your phone.

1. Select **Menu** → **Call History**.
2. Select a timer:
 - **Recent Calls Timer**—Tracks all calls you have made and received since you last reset this timer. To reset this timer to zero, press  to select **Reset**.
 - **All Calls Timer**—Tracks all calls you have made and received. This timer cannot be reset.
 - **Kilobyte Counter**—Tracks the kilobytes of data sent and received by the phone. This counter resets automatically. May not appear on all phones.

Timing your calls

You can set your phone to beep 10 seconds before each minute passes when you are on a call.

- Select **Menu** → **Settings** → **Sounds** → **Minute Alert** → **Enabled**.

Receiving data or faxes

Your phone may be able to receive certain data or faxes, depending on the system sending the information. For more information, see page 37.

Understanding roaming



Controlling network roaming

Depending on services available from your service provider, you may set the phone to either digital or analog mode. This is useful if you are in an area that borders on digital service and the automatic feature is causing the phone to keep switching between modes.

1. Select **Menu** → **Settings** → **Network** → **Digital/Analog**.
2. Select an option and press .
 - **Automatic** automatically switches the phone between digital and analog.
 - **Analog only** sets the phone to work in analog mode only.
 - **Analog call** forces a call into analog mode for the duration of the next call.
 - **Digital only** sets the phone to work in digital mode only.

Setting an alert for roaming

You may use this setting if you want the phone to alert you when you roam outside of your home service area.

1. Select **Menu** → **Settings** → **Network** → **Roam/Svc Alert**.
 2. Select an option and press .
 - **When no svc** alerts you with three tones decreasing in pitch when service is lost and three tones increasing in pitch when service is acquired again.
 - **On roam change** alerts you with two decreasing tones when roaming service is acquired and three increasing tones when home area service is acquired again.
 - **On any change** alerts you with three increasing tones if there is a change in roaming service or three decreasing tones if the phone loses service.
- The phone now emits a distinctive roam ring to indicate when you are roaming during calls.
 - To accept or place a call while roaming, you must press .

Note: This functionality is disabled when the phone is in emergency mode.

Setting the roam ringer

You can set a ringer to indicate when an incoming call will be subject to roaming charges.

1. Select **Menu** → **Settings** → **Sounds** → **Roam Ringer**.
2. Highlight **Enabled** to hear the ringer.
3. Press  to set.

Setting Call Guard

You can set the phone to warn you before you answer or place a call while roaming.

- Select **Menu** → **Settings** → **Convenience** → **Call Guard** → **Call prompt**.

3 ENTERING TEXT, NUMBERS, AND SYMBOLS

You can enter letters, numbers, and symbols in contacts, text messages, and your banner.

Understanding text entry screens

The current text entry mode (and capitalization setting, when applicable) are indicated by icons.

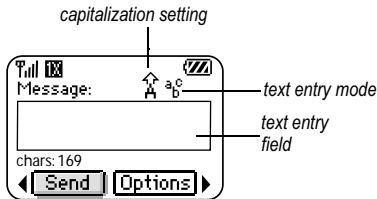

Text entry modes

There are four text entry modes:

- A>a Case change
- 123 Numbers only
- abc Normal alpha
- ezi Rapid Entry
- &? Add Symbol

Note: The mode you start in depends on the task you are doing. For example, when entering a phone number, you're in number mode. When entering a name for a contact, you're in normal text mode.

Entering numbers

- To enter a number while in 123 mode, press a number key once.
- To enter a number while in abc or ezi mode, press and hold a number key until the number appears on the screen.





abc Entering words letter by letter

Use normal alpha to enter letters.

- Press a key once for the first letter, twice for the second letter, and so on. If your phone is set to Spanish, French, or Portuguese, accented letters are available.
- Wait for the cursor to move right and enter the next letter.

ezi Entering words quickly

When you press a series of keys using ezi mode, ezi checks its dictionary of common words and guesses at the word you are trying to spell.

- For each letter of the word you want, press the key once. For example, to enter the word "any" press:  →  → .
- If the word doesn't match what you want, press  to look at other word matches.
- When you see the word you want, press .

&?! Entering symbols

While entering text, you can enter symbols by pressing  until you see the symbol you want. Using this method, you have access to the following symbols:

. & @ , 1 ‘ : ?

To access the full set of symbols:

1. Select **Options**.
2. Select **&?! Add Symbol**.
3. Press  down to view the list of symbols.
4. Press the number key corresponding to the symbol you want.

Switching default text entry modes

You can change the default text entry mode when creating a text message. This setting applies only to the message body screen, not the “To” screen.

1. Select **Menu** → **Messages** → **Msg Settings** → **Default Text**.
2. Select **Normal Alpha** or **Rapid Mode**.

Changing modes

Sometimes you need to change modes. For example, to enter numbers in an email address while in **a₁b₂c** mode, you must change to **1₂3** mode, enter the numbers, and then change back to **a₁b₂c** mode to complete the address.

To change text entry modes, you can either:











- Press and hold  until icon for the mode you want appears.
-or-
- Select **Options**, then the mode.

Capitalization settings

You can change capitalization at any time while entering text. Simply press  to choose upper or lower case while in Normal Alpha mode.

Quick reference to text entry



This table gives general instructions for entering letters, numbers, and symbols.

To...	Do this...
Enter a letter	Use a _b c mode and press a key until you see the letter you want. For more information, see page 16.
Enter a number	Use 1 ₂ 3 mode and press a key once to enter its number. For more options, see page 16.
Enter a symbol	Use a _b c mode and press  until you find the symbol you want. See page 17.
Enter a space	Press  .
Erase a character	Press  .
Erase all characters	Press and hold  .
Move the cursor right or left	Press  right or left.
Move the cursor up or down	Press  up or down.
Change text entry modes	Press and hold  .
Capitalize any letter	In a _b c mode, press  . Choose A .
Lowercase any letter	In a _b c mode, press  . Choose a .
Select soft options on the screen	Press the appropriate softkey,  or  .

4 STORING CONTACTS

Use your phone's Contacts directory to store information about a person or company. Your phone can hold, on average, about 200 phone numbers.





Creating a new contact

1. From the home screen, enter the phone number you want to save, including the area code.
 - **Menu** → **Contacts** → **Add New**, select an option, and skip to step 3.
2. Press  to select **Save**.
3. Enter a name for the contact. If you need to learn how to enter letters, see page 16.
4. Press  down once to move to the number field.
5. Enter the contact's phone number.
6. Press  to select **Save**.
7. Select **Options** to add information to the contact.
 - **Number Type** to designate a number as Work, Home, Mobile, Pager, or Fax.
 - **Add Speed Dial** to assign a speed dial number to your phone number.
 - **Add Voice Dial** allows you to add a voice tag to your added phone number.

- **Secret** hides the number from view in the contacts list and other areas of the phone.
- **Primary Number** assigns phone number as primary number for contact.
- **Time Pause** stops dialing for two seconds, then continues to dial.
- **Hard Pause** stops dialing until you select **Release**.

Adding a code or extension



When you save the phone number of an automated service, you may include a pause where your phone would stop dialing; for example, where you would wait to dial an extension.

1. Enter the first portion of the phone number.
2. Press  to select **Options**.
3. Select a type of pause:
 -  **A Time Pause**
 -  **A Hard Pause**
4. Enter the remaining numbers.
5. Press  to select **Save** and follow the prompts.





Editing or erasing a contact

To make changes to a contact, take these steps.

1. Select **Menu** → **Contacts**.

2. Select **View All** or **Find Name** to find the contact you want to edit.
3. Highlight the contact to edit and press .
4. Press  to select **Options**.
5. Highlight an option and press  to select it: **Add New**, **Assign Ringer**, **Unassign Ringer**, **Assign Picture**, **Unassign Picture**, **Edit Name**, **Erase Contact**, or **Classify Contact**.

Editing a phone number

1. Select **Menu** → **Contacts**.
2. Select **View All** or **Find Name** to find the contact you want to edit.
3. Highlight the contact to edit and press .
4. Press  down to highlight the phone number you want to edit.
5. Press  to select **Options**.
6. Highlight an option for the phone number and press :
 - **Send Text Msg**—Send a text message to the phone number you selected.
 - **View Number**—See the phone number you selected.
 - **Add Voice Dial**—Speak the name of the contact person for this number so that you can dial it using voice recognition (VR). For more information, see page 39.
 - **Add Speed Dial**—Assign or remove the location you use to speed dial the number.
- **Edit Type**—Assign a type: **work**, **home**, **mobile**, **pager**, or **fax**. The type icon appears next to the phone number in the Contacts list.
- **Erase Number**—Erase the number from the contact.
- **Erase Voice Dial**—Erase the voice dial name associated with the number.
- **Edit Number**—Change the phone number.
- **Edit Voice Dial**—Record a new voice dial name.
- **Secret**—Make the number secret so that it will not appear on the screen until the lock code is entered. Secret numbers can be called without a lock code. (For more information, see “Restricting calls” on page 36.)
- **Primary Number**—Make this number the first one that shows up when you open the contact.
- **Prepend**—Move the cursor to the beginning of the number so you can add the area code.
7. Enter the new information and follow the prompts.
8. Press  to select **Save**, if necessary.

Finding contact information

To find a phone number or contact, you can (1) check the frequent contacts list, (2) search the Contacts directory, or (3) use Fast Find.

Checking the Frequent List



Select the **Contacts** softkey to access all of your contacts in an alphabetical list. the last 15 of your most frequently called contacts (if you have enabled the Frequent List setting). You also see the All Contacts list if you scroll down past the double line.

To enable the Frequent List setting

- Select **Menu** → **Settings** → **Convenience** → **Frequent List** → **Enabled**.

Searching the Contacts directory

1. Select **Contacts** for a list of all contacts. To quickly get down the list, enter the first letter of the contact. The menu skips to that letter of the alphabet.
-or-
2. Select **Menu** → **Contacts**.
3. Select a search method:
 - **View All**—List all saved contacts.
 - **Find Name**—Locate a specific name. Enter part of the contact name, then select **Find**.
 - **Speed Dial List, Voice Dial List, Business List, or Personal List**—Select a contact from a list.



4. Scroll down until you find the name you want, then press .
 - To call the contact, highlight the number and press .
 - To display contact information, press .

Setting Fast Find

With Fast Find, you press one or two keys to view close matches of the number you are looking for.

- From the home screen, select **Menu** → **Settings** → **Convenience** → **Fast Find** → **Enabled**.

Using Fast Find

1. From the home screen, press the keys corresponding to the letters of the name you want to find. A matching contact or speed dial entry appears. Press  down to scroll through matching entries.
2. Highlight the name you want, then press  to call the number.

5 SENDING AND RECEIVING TEXT MESSAGES

This chapter describes how to send, receive, and erase text messages from your phone. For information on voicemail messages, see page 12.

Important: The features and menus described in this chapter may vary depending on services available in your area. In addition, usage charges may apply to each message. For details, check with your service provider.

Sending text messages

You can only send text messages to phones that are capable of receiving them, or to email addresses.

Text messages have a predetermined character limit. When you reach the character limit for a single message the phone beeps and asks you to edit the message to meet the size limitation. Note that signatures you create and assign count as characters in your messages.

Creating a text message





To send a text message to a single recipient:



1. Select **Menu** → **Messages** → **New Text Msg.**
2. Select an address to enter the recipient's phone number or email address:
 - Select a saved number from the **Recent List** or **Contacts List**, or select a **Group Lists** you have created. For more about group lists, see page 27.

- Enter a **New Address** manually.
(To learn how to enter text, see page 16.)

3. To add another recipient to this message, choose a method:
 - Press  to select **Options**. Then select **Recent List**, **Contacts**, or **Group Lists**.
 - Enter a space or comma after the first number. Then enter another recipient manually.





Note: You can send a message to up to 10 contacts at once. The messages will be sent one at a time, once to each addressee.

4. When you are done entering addresses, select **Next**.
5. Enter the message. To learn how to enter text, see page 16.
6. Select **Options** → **Insert**. Press  to add the following special features:
 - **Insert Sounds**—Add a sound or melody. Highlight one from the list and press  to select **Insert**.
 - **Insert Picture**—Add an existing picture, or a graphic you have received in a text message, created using Doodler, or downloaded to your phone. Press  right or left to scroll through graphics and press  to select **Insert**.

- **Insert QuickText**—Select a prewritten message. Highlight one from the list and press . (To edit or create new prewritten messages, see page 28.)
 - **Insert Contacts**—Add information about a saved contact. Highlight the contact from the list and press  to insert it.
7. When you have completed the message, you can send it immediately or set sending options. To send it immediately, press  to select **Send**. To set sending options, see the following procedure.

Setting sending options

When you are ready to send a message, you have several options for how and when you want the message to be received.

1. Once you have completed the message, press  to select **Options**.
2. Scroll to and press  to select **Options**. Then choose from the list:
 - **Add Address**—Return to the “To” screen to add another recipient without losing the message text. Enter the new address, then select **Next** to return to the message entry screen.
 - **Save Message**—Save the message in your **Saved** folder. This prevents the message from being deleted if you have activated AutoErase, and enables you to send the message to others.
 - **Save Quick Text**—Save the message you have just entered as a prewritten message, then return to the message entry screen so you can send the message.
 - **Settings** — Highlight Settings. Press . Choose from the following:
 - **Request Receipt**—Request notification when the message has been received.
 - **Set Priority**—Label the message as “Urgent.”
 - **Callback Number**—Include a callback number with the message to let the recipient know at what number they can call you back. Select **Yes** to include your own number, or **Edit** to enter a different callback number.
 - **Send Later**—Schedule when to send the message.
3. When you have finished setting options, press  to return to the message window.
4. Press  to select **Send**.

Adding a signature

The signature you create does not display in the message creation screen; however, the signature is included at the end of all outgoing messages and is counted as characters in your messages.

To create a signature

1. Select **Menu** → **Settings** → **Messaging** → **Signature**.

2. Enter your signature in the text field.
3. Press  to select OK to save the setting.

Note: The signature text is tallied by the character counter because the signature is included in the text field.

If you cannot send messages

You may not be able to send or receive messages if your phone's memory is nearly full, or if digital service is not available at the time. To free up memory, erase old messages. See “Erasing messages” on page 26.

Understanding appended messages

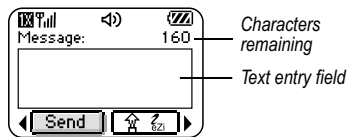

Characters remaining

Text entry field

If you go over the character limit for a single message, the phone may automatically append an empty segment to your message to make space.

Important: You will be charged for each message segment.

When you start a message, the maximum character limit (“160” in the example) appears above the text entry screen. This number counts down as you enter characters, until it reaches 0. If you continue to enter text after this counter reaches 0, a message segment may be appended. If a segment is

appended, a message will appear on the phone screen.

Receiving incoming calls while creating messages

- If you don't wish to answer the call, select **Ignore**. The phone returns to the message screen.
- To answer the call, press . Your message is saved to the Saved folder. To return to the message, select **Menu** → **Messages** → **Drafts** and select **Resume**.

Viewing the OutBox

You can check the status of messages you have sent as long as they have been saved to the OutBox.

To set the Outbox

The Outbox default is set to disabled to conserve memory. If you want to save your sent messages:

1. Select **Menu** → **Messages** → **Msg Settings** → **Save to Outbox**.
 - Select **Enabled** to save all sent messages to the Outbox
 - Select **Prompt** to alert you to choose whether or not to save your message.

To view the OutBox

1. Select **Menu** → **Messages** → **OutBox**.

2. Press  up or down through the list of messages. One of the following symbols appears next to each message:

 The message is pending and will be sent when possible. You can cancel delivery of the message.

 The scheduled message will be sent at the scheduled time. You cannot cancel delivery of the message.

 The message cannot be sent because service is not available. An alert appears on your phone if the message cannot be sent.

The scheduled message has been sent and will be delivered as scheduled. You cannot cancel delivery of the message.

The message has been received by the recipient you specified.

The message has been received and opened by the recipient you specified. (This symbol may not be available. Check with your service provider.)

 The message has been sent to more than one recipient.

The message has never been sent, or has not been sent since it was last modified. You can cancel delivery of the message.

Retrieving text messages



When a text message is received, your screen displays “New Messages”, along with the  symbol at the top of your screen. The symbol flashes if the message is urgent.

If your phone is set to **Direct View**, the body of the message will appear on the phone screen automatically.

To activate Direct View, select **Menu** → **Messages** → **Msg Settings** → **Direct View** → **Enabled**.

If you see the “New Messages” note

You can choose to:

- **View** the message—Press .
- **Ignore** the message—Press .

If you see the body of the message

The body of an incoming message will appear on your home screen only if your phone is set to Direct View.

You can choose to:

- **Ignore** the message—Press .
- **Read** the message. See “Reading the message” on page 26.

Note: If you receive a new message while you are reading a message, the one you are reading will be replaced by the new one. You can find the older message in the InBox: Select **Menu** → **Messages** → **InBox**.

If you see the symbol

If the  symbol is flashing, the message is urgent.

1. Select **Menu** → **Messages** → **InBox**.

A list of all your received messages appears.

New, unread messages appear in **bold**.

 indicates an “Urgent” message.

2. Press up or down to scroll through the list of messages.

3. Press in to read a message.

Reading the message

The options available to you may vary. Check with your service provider.

Note: Sounds embedded in text messages will not play if the phone is set to Silence All mode.

1. If the text message is long, press  down to view the entire message.
2. When you are finished, you can **Reply** to the sender, **Play** the sound embedded in the message, **Erase** the message, **Save** the message to your Saved folder, or set additional **Options** for the message:
 - View **Sender** information.
 - **Forward** the message.
 - **Reply with Copy** to reply to the message with a copy of the original attached.
 - **Save Object(s)**, such as sound or pictures, from the message. (This option is available

if the incoming message includes a graphic or sound.)

- **Save Contact** to save the sender’s phone number or email address in your Contacts list. (This option is available if a vCard is included in the message.)
- **Save as AutoText** to save the text from the message as AutoText, which you can insert into other messages. Graphics and sound will not be saved as part of AutoText. (For more about AutoText, see page 28.)

3. Select **Done**.

Note: The  symbol indicates that a graphic did not come through. It may be too large or incorrectly formatted.

Setting message alerts



You can set your phone to alert you of incoming text messages or pages. For more information, see “Setting message alerts” on page 32.

Erasing messages

Your phone is designed to store 99 text messages and pages. It is a good idea to erase old messages, as messages take up memory in your phone.

You have the option of erasing text messages and pages as you send or read them, erasing them one at a time from the list in the OutBox or InBox, or erasing them all at once.

Erasing single messages

1. Select **Menu** → **Messages**.
2. Press  down to the type of text message you want to erase: **InBox**, **OutBox**, or **Saved**.
3. Press .
4. Highlight the message to erase and press .
5. Select **Erase** to erase the message. A notification appears: "Erase this message?"
6. Select **Yes** to erase the message.

Note: You can erase a scheduled message from the **OutBox**, but you cannot cancel delivery of the message.

Erasing all messages

1. Select **Menu** → **Messages** → **Erase Messages**.
2. Select a folder to erase all messages from: **InBox**, **OutBox**, **Saved Folder**, or **Drafts Folder**. To erase messages from all folders, select **All Messages**.
3. A message appears: "Erase all messages?" Select **Yes** to erase messages or **No** to cancel.

Erasing messages automatically

Use this setting to have old messages automatically erased from the **InBox** when memory is low.

1. Select **Menu** → **Messages** → **Msg Settings** → **Auto-Erase**.
2. Highlight **Old InBox Msgs** and press . Older messages will now be erased as new messages are received.

- To disable this setting select **Select Menu** → **Messages** → **Msg Settings** → **Auto-Erase** → **Disabled**.

Customizing message settings

To make messaging easier, you can customize settings for sending and receiving messages.

Creating group lists

You can create and save a list of multiple recipients. Your Koi phone stores five group lists with up to 10 recipients per list.

1. Select **Menu** → **Messages** → **Group Lists** → **Create New**.
2. Enter a name for the list. For help entering text, see page 16.
3. Press  to select **Next**.
4. To enter the first phone number or email address, select an option:
 - **Recent List** to select numbers from your Recent List.
 - **New Address** to enter the phone number or email address manually.
 - **Contacts List** to select numbers from your phone book.
5. To enter the next address, enter a space or comma after the first number or email address. (If you insert a saved contact or a number from the Recent List, the phone will insert the comma automatically.)

6. Select **Options** to select the next number.
7. Select **Recent List** or **Contacts**.
8. When finished, select **Done**.
9. To send a message to your new group, see “Sending text messages” on page 22.

Creating and editing prewritten messages (QuickText)

Your phone comes with prewritten (QuickText) messages, such as “Please call me,” which you can insert into the body of a text message. You can edit these messages and create new ones. Your phone will store up to 20 QuickText messages, with up to 100 characters per message.

1. Select **Menu** → **Messages** → **Msg Settings** → **Edit QuickText**.
2. To create a new pre-written message, highlight **New Msg** and press .

-or-

To edit an existing pre-written message, highlight the message and press .

3. Enter or edit the text and press  to select **Done**. For help entering text, see page 16.

Note: You can also save an incoming message as AutoText. For directions, see page 26.

6 CUSTOMIZING YOUR PHONE

The contents of the **Settings** menu are as follows.

Silent Mode

Vibrate Only
Vibe then Ring
Lights Only
Normal Sounds

Sounds

Ring Volume
Ringer Type
Business Ringer
Personal Ringer
Roam Ringer
Open Swivel Sound
Close Swivel Sound
Pwr On/Off Sound
Key Volume
Key Length
Missed Call Alert
Smart Sound
Minute Alert
Earpiece Volume
Spkphone Volume

Display

My Banner
Main Menu View
Color Themes
Wallpaper
Screen Saver
Backlighting
Auto-Hyphen
Language
Time/Date Format
Contrast
Brightness

Convenience

Answer with Swivel
End with Swivel
Fast Find
Frequent List
Hold Call
1-Touch Dialing
Web Prompt
Call Guard

Voice Features

Add Voice Dial
Delete Voice Dial
Voice Training
Voice Wake-Up
Voice Answer
Expert Mode

Messaging

Alerts
Signature
Edit QuickText
Callback Number
Direct View
Save to OutBox
Auto-Erase
Default Text
Voicemail Num.
Security
Lock Phone
New Lock Code
Delete Contacts
Emergency Numbers

Network

Data/Fax Calls
Privacy Alert*
Voice Privacy*
Data Setup*
User Name*
Set Phone Line*
Roam/Svc Alert
Roam Option
Digital/Analog
Location

Accessories

Pwr Backlight
Headset Ringing
Auto-Answer
Com Port Speed
TTY Device





*Not available on all phones. Check with your service provider.

Silencing all sounds

Your phone is set to make sounds when you receive calls, press keys, navigate through menus, and receive alerts (such as new messages).



You can silence all sounds and set the phone to vibrate or light up when you receive calls and alerts.

Setting the phone to vibrate or light up

1. Select **Menu** → **Settings** → **Silent Mode**.
2. Choose an option and press :
 - **Vibrate Only**—Causes the phone to vibrate for the duration of the incoming call or other alert.  appears.
 - **Vibrate then Ring**—Causes the phone to vibrate for the first 10 seconds and then ring for the remainder of the incoming call alert.  appears.
 - **Lights Only**—Causes the phone to light up for the duration of the incoming call or other alert.  appears.
 - **Normal Sounds**—Causes the phone to ring for the incoming call or alert (in effect, returns phone to a non-silent mode).
3. Press  to return to the home screen.





Note: The phone will ring when it is attached to an external power source (such as a charger), even if all sounds have been silenced.

Shortcut to Vibrate Only mode

- With swivel closed, press  in twice. .
- With swivel open, press and hold .

Turning sounds back on

To restore all sounds to the phone:

- With swivel closed, press  in once.
- With swivel open, press and hold . The  or  disappears.

Choosing ringers

Your Kyocera K10 phone has 25 ringers you can choose to use for incoming calls.

1. Select **Menu** → **Settings** → **Sounds** → **Ringer Type**.
2. Scroll down the list to hear the different ringers.
3. Press  to select a ringer from the list.



Note: Downloaded ringers are added to the end of the standard list of 25 ringers.

Assigning business and personal ringers

You can assign ringers to contacts classified as business or personal in your Contacts directory.

Note: To classify a contact as Business or Personal, see page 19.

1. Select **Menu** → **Settings** → **Sounds**.

2. Highlight **Business Ringer** or **Personal Ringer** and press .
3. Select a ringer and press .

Assigning a ringer to a contact

1. Select **Menu** → **Contacts** → **View All**.
2. Select the contact to assign a ringer to.
3. Select **Options** → **Assign Ringer**.
4. Highlight the ringer you want and press .

Importing ringers

You can download additional ringers to your phone using the Kyocera Phone Desktop software (sold separately). To purchase this software and other accessories, visit www.kyocera-wireless.com/store.

Setting sounds for your phone

You can set your phone to sound tones when you open and close the swivel, and when you turn the phone on and off. Sounds will not occur during an incoming call, if you are in a call, or if a headset or car kit is attached to your phone.

Set sound when swivel opens

1. Select **Menu** → **Settings** → **Sounds** → **Open Swivel Sound**.
2. Scroll through the list to hear the sounds.
3. Select a sound and press  to save.

Set sound when swivel closes

1. Select **Menu** → **Settings** → **Sounds** → **Close Swivel Sound**.
2. Scroll through the list to hear the sounds.
3. Select a sound and press  to save.

Set sound when phone powers on or off

1. Select **Menu** → **Settings** → **Sounds** → **Pwr On/Off Sound**.
2. Select **Enabled**. To deselect this sound, select **Disabled**.



Adjusting volume

You can adjust the earpiece, speakerphone, and ringer volume as well as key tones.



Adjusting the earpiece volume

To adjust the earpiece volume manually during a call, press  up or down to find a comfortable level.



To set the earpiece volume

1. Select **Menu** → **Settings** → **Sounds** → **Earpiece Volume**.
2. Press  right to increase the volume, or left to decrease the volume.
3. Press the left softkey  to select **Save**.

Adjusting the ringer volume



1. Select **Menu** → **Settings** → **Sounds** → **Ringer Volume**.
2. Press  right to increase the volume, or left to decrease the volume.
3. Press left softkey  to select **Save**.

Adjusting speakerphone volume

1. Select **Menu** → **Settings** → **Sounds** → **Spkrphone Volume**.
2. Press  right to increase the volume, or left to decrease the volume.
3. Press  to select **Save**.

Adjusting key tone volume

You can change the volume and duration of the tones the phone makes when you press the keys.

1. Select **Menu** → **Settings** → **Sounds** → **Key Volume**.
2. Press  right to increase the volume, or left to decrease the volume.
3. Press  to select **Save**.



Setting key length

You can change duration of the tones the phone makes when you press the keys.

1. Select **Menu** → **Settings** → **Sounds** → **Key Length**.
2. Choose Normal or Long.
3. Press .





Setting message alerts

You can choose how you want be alerted of incoming voicemail, pages, or text messages.

1. Select **Menu** → **Settings** → **Messaging** → **Alerts**.
2. Select the type of alert: **Text Message Alert**, **Net Alert**, **Page Alert**, or **Voicemail Alert**.
3. Press  to select an option:
 - **Vibrate Once** sets the phone to vibrate or beep once when a new message is received.
 - **Vibe & remind**, **Beep and Remind** sets the phone to notify you once when a new message is received and then notify you again every five minutes. To stop a reminder alert, press  to select **Ignore**.
 - **Disabled**—Turn off message alerts.





Using shortcuts

Your Kyocera Koi phone comes with four shortcuts when in standby mode.





Press  up	Access your custom menu
Press  down	Access recent calls
Press  left	Launch Web browser
Press  right	Record voice memo

Creating a custom menu

You can create a custom menu that contains your favorite features. After you set up your menu, simply press and hold  up to access it.

1. Press and hold  up to launch **Custom Menu**.
2. Press  to select **Manage List**.
3. Scroll through the available options.
4. Press  to select or deselect options. You may select more than one feature. Items appear in alphabetical order in the menu.
5. Highlight **Save changes** and press .

Updating your custom menu

1. Press and hold  up to launch **Custom Menu**.
2. Press  to select **Manage List**.
3. Press  to select or deselect options.
4. Highlight **Save changes** and press .

Creating a shortcut to frequent contacts

By default, your phone lists your entire contacts list when you select the **Contacts** softkey. You can also set the phone to show a list of your most frequent contacts.

1. Select **Menu** → **Settings** → **Convenience** → **Frequent List**.
2. Select **Enabled** to include the list or **Disabled** to remove it.

Using the Frequent Contacts shortcut

- From the home screen, press  to select **Contacts**. Your 15 most frequently called contacts appear at the top of the list, followed by your complete contact list.

Choosing a different language



Your phone may display alternative languages.

1. Select **Menu** → **Settings** → **Display** → **Language**.
2. Select a language, and press .

Personalizing the screen

Changing your banner







The banner is the personal label for your phone. It appears on the home screen above the time and date. The banner can be up to 14 characters long.

1. Select **Menu** → **Settings** → **Display** → **My Banner**.
2. Press  to select **Edit**.
3. Press  to clear the screen.
4. Enter your new text.
5. Press  to select **Save**.

Choosing a menu view

Three menu views are available:

1. Select **Menu** → **Settings** → **Display** → **Main Menu View**, then the option you want:

- **Wheel** a graphical and dynamic view that you scroll by pressing  or  up or down.
 - **Graphic** a graphical icon view of menu items that you scroll by pressing  up and down or  in all directions.
 - **List** provides menu items in a vertical text display. Press  or  up or down to scroll through the list.
2. Press  to return to the home screen. The next time you select **Menu**, you will see the menu view you selected.

Adjusting the backlighting

Your screen lights up while you are in a call or when you press a key on the keypad. However, you can set the length of time that bright backlighting remains on.

1. Select **Menu** → **Settings** → **Display** → **Backlighting** → **Duration**.
2. Select an option from the list:
 - **5 seconds, 10 seconds, or 30 seconds**—(Default) Turn backlighting on for 5, 10, or 30 seconds after your last keypress.
 - **5 sec. & in call, 10 sec. & in call, or 30 sec. & in call**—Turn backlighting on for the duration of a call, and for 5, 10, or 30 seconds after your last keypress.

Note: These settings drain the battery more quickly and reduce talk and standby times.

Using Power Save Mode

To save power when using backlighting, turn on power save mode to dim the backlight set in the procedure above. The backlight appears for the set amount of time, but is less bright than it is with power save off.

1. Select **Menu** → **Settings** → **Display** → **Backlighting** → **Pwr Save Mode** → **On**.



Setting power backlighting

You can set backlighting to remain on when an external power source, such as the AC adapter, is used with the phone.

Note: Power backlighting may not be available with some accessories.

1. Select **Menu** → **Settings** → **Accessories** → **Pwr Backlight**.
2. Select **Always On** to keep backlighting on.
Note: The battery charges more slowly when power backlighting is on.

Changing the display contrast

1. Select **Menu** → **Settings** → **Display** → **Contrast**.
2. Press  left or right to adjust the contrast.
3. Press  to select **Save**.

Setting numbers to auto-hyphenate



Auto-hyphenation, when enabled, automatically inserts hyphens into your phone numbers to be

consistent with the U.S. dialing plan.
For example, 1-222-333-4444.

- Select **Menu** → **Settings** → **Display** → **Auto-Hyphen** → **Enabled**.

Selecting a screen saver



Screen savers appear on the home screen when the swivel is open or closed and are activated 10 seconds after the last keypress. Incoming calls and alerts override screen savers.

1. Select **Menu** → **Settings** → **Display** → **Screen Saver**.
2. Highlight a screen saver and press . The image displays.
3. Press  to assign the screen saver.
4. Press  to return to the home screen and wait 10 seconds to view the screen saver you chose.

Note: Downloaded screen savers are added to the end of the list.



Selecting wallpaper

Wallpaper appears on the home screen.

1. Select **Menu** → **Settings** → **Display** → **Wallpaper**.
2. Highlight a wallpaper design and press .
3. Press  to return to the home screen and view the wallpaper you chose.

Selecting a color theme

You can select a color theme for your phone.

1. Select **Menu** → **Settings** → **Display** → **Color Themes**.
2. Highlight a color theme from the list and press .
3. Press  to return to the home screen.

Choosing a different time/date format

1. Select **Menu** → **Settings** → **Display** → **Time/Date Format**.
2. Highlight the option you want.
3. Press  to save the setting.

Creating a secure environment

This section describes all the features involved in securing your phone and preventing access to personal information. All security features are shielded by a four-digit lock code.

Changing your lock code

The lock code is typically 0000 or the last 4 digits of your phone number.

1. Select **Menu** → **Settings** → **Security**.
2. Enter your four-digit lock code
3. Select **New Lock Code**. A message appears: “Change Code?”
4. Press  to select **Yes** and enter a new four-digit code.

5. Enter your new lock code again.

Locking your phone

When your phone is locked, you can call only emergency numbers or your service provider number. You can still receive incoming calls.

1. Select **Menu** → **Settings** → **Security**.
2. Enter your four-digit lock code.
3. Select **Lock Phone**.
4. Highlight an option:
 - **Never** does not lock the phone.
 - **On power up** locks the phone every time you turn it on.
 - **Now** locks the phone immediately.
5. Press .

Unlocking the phone

1. From the home screen, press  to select **Unlock**.
2. Enter your four-digit lock code.

Designating emergency numbers

The emergency numbers feature allows you to specify three personal phone numbers that can be called when the phone is locked.

1. Select **Menu** → **Settings** → **Security**.
2. Enter your four-digit lock code.
3. Select **Emergency Numbers**.
4. Select an **Unassigned** slot.

5. Enter the phone number, including the area code. Do not enter 1 before the area code.
6. Press  to select **Done**.

Notes:

- You can view these numbers only when they're being entered for the first time.
- You cannot edit these numbers.
- To make a call to an emergency number from a locked phone, you must dial the number (including area code) exactly as it was stored in Emergency Numbers.

Restricting calls

You can restrict the calls that can be made from your phone to emergency numbers, your contacts, and service provider numbers.

1. Select **Menu** → **Settings** → **Security**.
2. Enter your four-digit lock code.
3. Select **Limit Calls**.
4. Choose an option:
 - **No Limit** limits no calls.
 - **Limit Outgoing** calls only. Incoming calls can still be received and answered.
 - **Limit All** calls, both incoming and outgoing.

Erasing all contacts

You can erase all entries from your Contacts directory.

1. Select **Menu** → **Settings** → **Security**.

2. Enter your four-digit lock code.
3. Select **Delete Contacts**.
4. Select **Yes** to erase all contacts. A message appears: "Erase ALL contacts?"
5. Press  to select **Yes** to erase all contacts.

Network settings

Switching between phone lines

Your phone can have two service accounts, or phone lines, associated with it. Each phone line has its own phone number. When you are using one line, you cannot receive calls from the other. It would be as if the phone were "off" for that number. Your voicemail, however, will still take messages. All contacts and settings are shared for both lines.

Note about service provider!

1. Select **Menu** → **Settings** → **Network** → **Set Phone Line**.
2. Select one of the two lines and press .

Data Setup

Sets the connection type for data applications. If you're experiencing difficulties connecting with an external device, check the settings on that device.

- **Automatic** selects the best connection type based on the current service.
- **QNC** allows standard circuit switched data calls.

- **1XRTT** Only XRTT allows the phone to utilize high-speed packet data, if available.

Setting Com port speed

The Com Speed sets the data rate at which your phone connects to a laptop or PC, or at which it sends and receives over-the-air text messages.

1. Select **Menu** → **Settings** → **Accessories** → **Com Port Speed**.
2. Select the speed. The options are: **19.2 kbps**, **115.2 kbps** (default), **230.4 kbps**.

Note: There may be a higher charge for making calls using high-speed data in areas where 1X service is available. Check with your service provider for details.

Setting the phone to receive data or faxes

Your phone may be able to receive certain data or faxes, depending on the system sending the information. You cannot receive voice calls while the phone is in data/fax mode. To receive data or faxes, you must connect the phone to a laptop or PC and switch the phone from voice mode to data/fax mode.

Note: To purchase a cable call (800) 349-4188 (U.S.A. only), (858) 882-1410, or visit www.kyocera-wireless.com/store.

1. Connect the phone to the laptop or PC.
2. Set the Com speed.

3. Select **Menu** → **Settings** → **Network** → **Data/Fax Calls**.
4. Press  to select an option:
 - **Voice only**—Allow only voice calls.
 - **Fax, next call** or **Data, next call**—Set the phone to fax mode or data mode for the next incoming call or the next 10 minutes.
 - **Fax, until off** or **Data, until off**—Force the phone into fax mode or data mode until the phone is turned off.

Note: You cannot receive voice calls while the phone is in data/fax mode.

Connecting to a TTY/TDD device

You can connect the phone to a TTY device for the hearing impaired. **Note:** Enable TTY only when using the phone with a TTY device.

1. Connect the TTY device to the phone.
2. Enter     
from your keypad.
3. Press  to select the TTY option.

Setting position location



This setting allows you to share your location information with network services other than emergency services (911, 111, 999, 000, etc.), in markets where service has been implemented.

Note: This feature works only when your phone is in digital mode. You do not have the option of turning off the locator to emergency services.

1. Select **Menu** → **Settings** → **Network** → **Location**.
2. At the message prompt, press  to select **OK** and continue.
3. Select **911 Only** or **Location On**.
 - **911 Only** (default) shares your position information only with emergency services when you call your 3-digit emergency code (911, 000, 111, etc.).
 - **Location On** shares your position information with your service provider's network, in addition to emergency services.

7 USING VOICE RECOGNITION

Voice recognition allows you to make and answer calls by speaking commands into the phone's microphone.

Note: You cannot use voice recognition to end a call; you must press  when the swivel is open, or press  in when the swivel is closed.

Setting up voice dialing

To make or receive calls using voice dialing, contacts must be saved with associated voice tags.

Creating a voice tag for a contact



1. Select **Menu** → **Contacts** → **Add Voice Dial**.
2. Follow the voice prompts to record a name for the contact.
3. Highlight an option:
 - **Add new**—Save a new contact to go with the voice tag.
 - **Add to existing**—Add the voice tag to a saved contact.

Viewing entries with voice tags



- Select **Menu** → **Contacts** → **Voice Dial List**.
A list of all contacts with assigned voice tags appears.

Editing a voice tag



1. Select **Menu** → **Contacts** → **Voice Dial List**.

2. Highlight the contact you want to edit, and press  to select it.
3. Highlight the phone number and press .
4. Select **Add Voice Dial**, **Edit Voice Dial**, or **Erase Voice Dial**.
5. Follow the prompts.

Calling using voice tags

1. If you haven't already done so, record a voice tag for the person you wish to call.
2. With the swivel closed, press  in once and scroll to Voice Dialing
-or-
With the swivel open, from the home screen, press . The phone responds: "Say a name."
 3. Say the name of the person you want to call.
 4. If the name you said matches a contact in the Voice Dial List, the phone responds: "Calling (Name)." Remain silent to make the call, or say "No" to cancel.

Note: If the phone finds multiple voice tags that sound like the name you said, you will be asked to verify which name you want to call. Say "Yes" when you hear the correct name. Say "No" when you hear an incorrect name.

5. When you are finished with the call, press  if the swivel is open, or  in if the

swivel is closed. You cannot end the call with a voice command.

Erasing voice tags

To erase all voice name dial recordings in your phone:

1. **Menu** → **Settings** → **Voice Features** → **Delete Voice Dial**.
2. Select **Yes**.

Calling using digit dialing

When using digit dialing, you speak digits to dial a phone number.

Note: You cannot speak a string of digits. You must speak one digit at a time and wait for the prompt.

1. From the home screen, press . The phone responds: “Say a name or say Dial.”
2. Say “**Dial**.” The phone responds: “Speak a digit.”
3. Speak the first digit of the phone number you want to call. Once the phone repeats the digit, you can speak the next digit.

If you pause, the phone will prompt you with the following five options. After the prompt, speak an option.

- Say “**Clear**” to erase the digit last entered. The phone responds: “Digit cleared.” To clear the entire phone number, say “Clear” again. When the phone prompts you

with “Clear entire phone number?”, say “Yes” to clear or “No” to cancel.

- Say “**Call**” to dial the number.
- Say “**Verify**” to cause phone to repeat the set of digits that you input.
- Say “**Cancel**” to exit voice recognizer and return to the home screen.
- Speak a digit to enter the next digit. Once the phone repeats the digit, you can speak the next digit or pause to hear the prompt.

Using voice features with accessories

You can use voice commands to make a phone call or to answer the phone only if your phone is connected to an accessory such as a hands-free car kit or headset (both sold separately).

To shop for these accessories, visit www.kyocera-wireless.com/store or call 800 349-4188 (U.S.A. only) or 858 882-1410.

Waking up the phone

If your phone is connected to a Kyocera hands-free car kit or headset, you can use a voice command to activate the phone to make a call.

To activate the Voice Wake-up setting:

- Select **Menu** → **Settings** → **Voice Features** → **Voice Wake-Up** → **With ext. pwr**.

To wake up the phone:

1. Say “**Wake Up**” and listen for a tone.

2. Say **“Wake Up”** again until you hear two tones. If the phone does not recognize your **“Wake up”** command, see **“Training voice recognition”** on page 41.

Answering the phone

You can set the hands-free car kit to either (1) answer automatically or (2) ring until you press a key or answer using a voice command.

Answering automatically

To set it to answer automatically:

- Select **Menu** → **Settings** → **Accessories** → **Auto-Answer** → **After 5 secs.**



Answering using voice commands

If Auto-Answer is turned off, you can use a voice command to answer an incoming call using the hands-free car kit or headset.

To turn off Auto-Answer

- Select **Menu** → **Settings** → **Accessories** → **Auto-Answer** → **Disabled.**

To activate the Voice Answer setting

1. Make sure the phone is not in Silence All mode. Your phone is in Silence All mode if one of these icons appears on your screen. See page 30.

2. Select **Menu** → **Settings** → **Voice Features** → **Voice Answer.**
3. Highlight **Enabled**, then press .

To answer a call

When you receive an incoming call, the phone responds: **“Incoming call, answer?”** or **“Incoming roam call, answer?”** If the caller is recognized as a saved contact entry, then the phone will say **“Incoming call from (Name), answer?”**

- Say **“Yes”** or press any key except .

To ignore an incoming call

- Say **“No”** and press  to silence the alert.
- Remain silent. The voice alert repeats twice and the phone rings once, then returns to the home screen.

Training voice recognition

If your phone is having trouble recognizing your voice, you can train it with the commands **“Yes,” “No,”** and **“Wake up.”**

1. Select **Menu** → **Settings** → **Voice Features.**
2. Select **Voice Training.**
3. Read the message and press  to select **OK** and continue. **Cancel** returns you to the previous screen.
4. Select **Train All** or the item you want to train.
5. Follow the prompts for each word until training is complete.



8 USING THE CAMERA



Tips before operating your camera

- You cannot activate the camera while on an active call or while browsing files in the media gallery.
- The lens cover must be open before you can take a picture.
Note: When the phone is powered on and in an idle state, opening the lens cover causes the phone to automatically go into camera mode.
- Once the LCD on the camera is active, the homescreen acts as the viewfinder.
- If you run out of memory, check your resolution and quality compression settings. See “Setting up the camera” on this page.
- If there is no activity within approximately 45 seconds after you turn your camera on, then the camera quits and returns to the previous launch point.

Setting up the camera

Menu settings can only be accessed when the camera is in an active mode.

1. With the swivel open, select **Menu** → **Camera**.
2. Press  to select **Options**.
3. Scroll left or right on the horizontal menu bar using .

4. Highlight the **Settings** option. Press .
5. Scroll down using . Highlight one of the following settings and press :
 - **Flash** On, Off, or Automatic
 - **Resolution** options are 1280 x 960, 640 x 480, 352 x 288, 320 x 240, 176 x 144, 160 x 120.
 - **Self Timer** options are Off (default) or 3, 5, or 10 second pauses. When set, the camera beeps tones from 3 seconds down to the time the shutter snaps the picture automatically. Self Timer is not available when **MultiShot** mode is activated.
 - **MultiShot** options are On or Off (default). When set to On, the camera allows you to take multiple pictures (up to six) while the camera key is pressed and held. A tone will play each time a picture is taken. A second tone will play when the final picture is taken.
 - **Shutter Sound** sets the sound used when the shutter closes while taking a picture.
 - **White Balance** allows the camera to adjust to whites. Options are Automatic, Fluorescent, Incandescent, or Daylight.
 - **Quality** sets the picture compression. The higher the compression, the better the detail

of the picture (higher pixel rate). Options are Low, Medium, or High (default). When set to High, the picture file size is larger, using more memory.

- **LED** flashes a light to indicate a picture has been taken. Options are On (default) and Off.

Restoring camera menu settings

The following settings **revert back** to the default setting each time you enter and exit the camera application:



Zoom, Brightness, Contrast, Camera, MultiShot, Color tone, Frames, Self Timer, and Picture Layout.

The following settings **remain** at the setting you selected each time you enter and exit the camera application:

White Balance, Flash, Resolution, Quality, Shutter Sound, and LED.

Menu options for camera mode



Menu options can only be accessed when the camera is in an active mode.



1. Select **Menu** → **Camera**.
 2. Press  to select **Options**.
 3. Scroll left or right on the horizontal menu bar using .
- **Last Pic** shows the most recent picture taken.
 - **Video Mode** toggles between video and camera modes.

- **Camera Pictures** displays all pictures taken and stored.
- **Cancel** is available only when the swivel is closed and dismisses menu options.
- **Quit** is available only when the swivel is closed and dismisses returns to previous screen display.
- **Brightness** allows you to adjust the brightness of the image in the homescreen LCD.
- **Contrast** allows you to adjust the contrast of the image in the homescreen LCD.
- **Frames** allows you to add a frame or a stamp to your picture. A frame or stamp cannot be removed once it has been used in a picture.
Note: The picture resolution changes to 176 x 144 while taking pictures with frames. The resolution returns to original setting once frames is disabled.

Camera mode indicators and icons

The camera mode displays the following onscreen indicators and icons:

Indicator/Icon	Description
	Flash on
	Camera mode
	Video mode

Indicator/Icon	Description
Numbers	Number of snapshots remaining
	Zoom level
Numbers	Resolution setting
	Multi Shot
	Self Timer (when camera/capture key is pressed, the icon switches to a number and begins counting down)

Taking a picture

Swivel open

1. Select **Menu** → **Camera**.

Tip: Slide the shutter cover on the back of the phone open. This automatically turns the camera on if the phone is already powered on and in an idle state.



2. Focus on the image using the homescreen as a viewfinder.

Tip: Press  or  up or down to zoom in or zoom out.

3. There are three ways to take a picture:

- Press  in
- Press 

- Press . This is the **Capture** function on the menu screen.

4. The image is immediately saved to **Media Gallery**.
5. Press  to return to the viewfinder and take more pictures.
6. Press  when finished taking pictures.



Tip: Closing the shutter cover on the back of the phone will exit the camera mode.

Swivel closed

1. Press  in and scroll to **Camera**.

Tip: Slide the shutter cover on the back of the phone open. This automatically turns the camera on if the phone is already powered on and in an idle state.

2. Press  in again.
 - A vertical row of options appears on the left of the screen: **Quit, Brightness, Contrast, Frames, Last, Video Mode, Camera Pictures, Settings, and Cancel**.
3. Focus on the subject you want to capture.

Tip: Use  to zoom in or out.
4. Press . The picture is taken and saved with a filename on top.
5. Press  to return to the vertical row of options. Select **Quit** when finished taking pictures.

Sending a picture





If your service provider supports picture messaging application you can send pictures through text messaging.

Note: You can only take and send pictures with the swivel open.









1. Take the picture.
2. Select the **Send** softkey. This launches the messaging application.
3. Write your message. See “Creating a text message” on page 22.
4. If you were taking pictures in Multi Shot mode, only the last picture is used when you select **Send**.



Camera key map

Swivel closed

Key	Camera Function	Menu Screen Function
 In	Takes picture	Dismisses menu options
	Displays menu	Selects menu option in focus
 Left (or down)	Zoom out	Scroll menu option left
 Right (or up)	Zoom in	Scroll menu option right









Swivel open

Key	Camera Function	Menu Screen Function
 In	Takes picture	Dismisses menu options
	“Capture” – takes picture	“OK” – selects option
	“Options” – activates options	“Cancel” – dismisses menu
 Up	Zoom in/	Scrolls menu options left
 Down	Zoom out/	Scrolls menu options right
 \odot K	Takes picture/	Select menu option
 In	Takes picture/	Select menu option
 Up	Zoom in	Scrolls menu options right
 Down	Zoom out	Scrolls menu options left

	Exit camera mode	Dismisses menu options
	Exit to idle	Exit to idle





Setting up the video camera

Menu settings can only be accessed when the camera is in an active mode.

1. Select **Menu** → **Camera**.
2. Press  to select **Options**.
3. Scroll left or right on the horizontal menu bar using . Highlight **Video Mode**.
4. Press .
5. Press  to select **Options**.
6. Scroll left or right on the horizontal menu bar using .
7. Highlight the **Settings** option. Press .
8. Scroll down using . Highlight one of the following settings and press :
 - **White Balance** allows the camera to adjust to whites. Options are Automatic, Fluorescent, Incandescent, or Daylight.
 - **Quality** sets the video compression. The higher the compression, the better the detail of the video. Options are Low, Medium, or High (default). When set to High, the video file size is larger, using more memory.
 - **Start Sound** allows you to turn the video record on and off tone. Options are On (default) and Off.
 - **LED** lights and stays steady during video recording. Options are On (default) and Off.

Menu options for video mode

Menu options can only be accessed when the camera is in an active mode.

1. With the swivel open, select **Menu** → **Camera**.
2. Press  to select **Options**.
3. Scroll left or right on the horizontal menu bar using . Highlight **Video Mode**.
4. Press .
5. Press  to select **Options**.
6. Scroll left or right on the horizontal menu bar using .
 - **Play Last Video** plays the most recent video taken.
 - **Brightness** allows you to adjust the brightness of the image in the homescreen LCD.
 - **Contrast** allows you to adjust the contrast of the image in the homescreen LCD.
 - **Camera Mode** toggles between video and camera modes.
 - **Video Album** displays all videos taken and stored.
 - **Settings** allows you to change your camera settings. See “Setting up the camera” on page 42
 - **Cancel** is available only when the swivel is closed and dismisses menu options.
 - **Recording Sound** – Allows you to turn the sound On/Off to indicate start/stop/pause while recording a video. A recording tone will play

prior to the start of recording and immediately after the recording has been stopped or paused.









Recording a video

The camera can record a video. When you begin recording a tone sounds, the video record icon blinks, and a “Recording” indicator with a timer progress bar displays. A tone sounds when the video stops recording.

Swivel open







1. Select **Menu** → **Camera**.

Tip: Slide the shutter cover on the back of the phone open. This automatically turns the camera on if the phone is already powered on and in an idle state.

2. Press  to select **Options**.
3. Scroll left or right on the horizontal menu bar using  to select the **Video Mode** option.
4. Focus on the image and press  to select **Record**.
Tip: Press  or  up or down to zoom in or zoom out.
5. If you want to pause the recording, press  to select **Pause**. To continue recording, press  to select **Resume**.
6. When finished recording, press  to select **Stop**.
7. The recorded video is immediately saved to **Media Gallery** → **Videos** → **Video Album**.





8. Press the **Back** or **End** softkey when finished taking videos. This will take you back to the main menu screen.

Swivel closed







1. Press  in and scroll to **Camera**.
Tip: Slide the shutter cover on the back of the phone open. This automatically turns the camera on if the phone is already powered on and in an idle state.
2. Press  in again.
 - A vertical row of options is on the left of the screen: **Quit**, **Brightness**, **Contrast**, **Frames**, **Last**, **Camera Pictures**, **Video Mode**, **Settings**, and **Cancel**.
3. Press  up or down and highlight **Video Mode**.
4. Press  in again.
5. Focus on the subject you want to video.
6. Press . Recording continues until you press  a second time, or when the recording timer ends.
7. The recorded video is immediately saved to **Media Gallery** → **Videos** → **Video Album**.
8. Press  to return to the vertical row of options. Select **Quit** when finished taking videos.



Video key map

Swivel closed

Key	Video Camera Function	Menu Screen Function
	1st press – start recording (plays a tone) 2nd press – stops recording (plays a tone)	Dismisses menu options
	Before recording: displays menu During recording: 1st press – pause 2nd press – selects option	Selects menu option
 Left (or down)	Zoom out	Scroll menu option left
 Right (or up)	Zoom in	Scroll menu option right

Swivel open

Key	Video Camera Function	Menu Screen Function
	1st press – start recording toggle 2nd press – stops recording toggle	Dismisses menu options
	“Record” – starts recording toggle “Stop” – stops recording toggle	“OK” – selects option
	“Options” – while not recording “Pause/Resume” – pauses and resumes recording toggle	“Cancel” – dismisses menu
	When not recording, goes back to the last function. While recording, stops recording.	Dismisses menu options
	Exit to idle when not recording. While recording, stops and saves the video in the background. Exits to idle.	Exit to idle.
 Up	Zoom in	Scrolls menu options left

 Down	Zoom out	Scrolls menu options right
 Up	Zoom in	Scrolls menu options right
 Down	Zoom out	Scrolls menu options left



9 USING MEDIA GALLERY

The media gallery stores all the files in the phone and displays files.

Accessing files

1. Select **Menu** → **Media Gallery**.
2. Select an option:
 - **Camera Pictures** displays your photos taken in a table/thumbnail view. The photos display in chronological order with the newest one first (top left corner). The file name also displays.
 - **Images** displays a list of categories that contain preloaded, downloaded, saved, or created files such as wallpaper, screen savers, or caller IDs.
 - **Sounds** displays a list of categories that contain saved or downloaded sounds such as ringtones, voice memos, and camera shutter sounds.
 - **Videos** displays a list view of the file names of videos that you recorded.





Browsing pictures



1. Select **Menu** → **Media Gallery** → **Camera Pictures**.
2. Press  to select **OK**, or Press .
3. Highlight a picture and select **Options**. The following options are available to you:

- **Send** launches the messaging application so you can share the photo.
- **Take Picture** to snap another photo.
- **Erase** the image.
- **Assign** picture as a Caller ID or as wallpaper.
- **Rename** the photo.
- **Details** of the file.
- **Erase All** photos.

Modifying pictures



You can modify a picture by rotating, resizing, or changing the brightness, sharpness, saturation, hue, auto adjust and/or color tone.

1. Select **Menu** → **Media Gallery** → **Camera Pictures**.
2. Press  or select **OK** softkey.
3. Use  to highlight a picture. Press  or select **View**.
4. Press the **Options** softkey.
5. Use  to scroll down and highlight **Modify**.
6. Press .
7. Press the **Options** softkey.
8. The following options are available to you:
 - **Rotate** options are 90 degrees right, 180 degrees, 90 degrees left, Flip horizontal, or Flip vertical.

- **Resize** will decrease the photo or image resolution by 90%, 75%, 50%, or 35%. This will create more memory space.
 - **Brightness, Sharpness, Saturation, and Hue** display bar is shown and can be increased by pressing  right, or decreased by pressing  left.
 - **Auto Adjust** allows you to brighten dark photos or darken bright photos.
 - **Color Tone** options are Grayscale, Negative, Sepia, and Emboss. When chosen, the camera allows you to modify the color tone of a photo.
9. Select the **Save** softkey when done modifying. From the Save Changes menu, choose **Save** (saves your original file with modifications), or **Save as new** (creates a modified file from your original file).

Browsing images

The images menu allows you to assign your files to various applications.



1. Select **Menu** → **Media Gallery** → **Images**.
2. Use  to highlight the menu item you want:
 - **Saved Images** displays photos you have taken.
 - **Wallpapers** displays wallpaper selections.
 - **Screen Savers** displays available screensavers.
3. Select **Open** to display the files in that menu.
4. Select the **Options** softkey. Choose from the following options:
 - **Send** launches the messaging application so you can share the image.
 - **Erase** the image (image must not be locked).
 - **Send to Online** uploads an image to a server (not available on all phones, check with your service provider).
 - **Details** gives you the file size of the image.
 - **Erase All** erases all images stored (images must not be locked).
5. Select the **Close** softkey or  when done.

Browsing sounds

1. Select **Menu** → **Media Gallery** → **Sounds**.
2. Use  to highlight the menu item you want:
 - **Saved Sounds** contains sounds saved on your phone.
 - **Ringers** contains ringers saved on your phone.
 - **Voice Memos** contains voice memos you made to yourself.

- **Shutter Sounds** contains different sounds your camera makes when you take a picture.
3. Select **Open** to display the files in that menu.
 4. Select the **Options** softkey. Choose from the following options:
 - **Send** launches the messaging application so you can share the sounds.
 - **Erase** the sounds.
 - **Send to Online** uploads a sound to a server (not available on all phones, check with your service provider).
 - **Details** gives you the file size of the sound.
 - **Erase All** erases all sounds stored.
 5. Select the **Close** softkey when done.

Browsing videos

1. Select **Menu** → **Media Gallery** → **Videos**.
2. Use  to highlight the menu item you want:
 - **Video Album** contains videos taken with your camera.
 - **Saved Videos** contains videos that were downloaded.
3. Select **Open** to display the files in that menu.
4. Select **Play** to review a video on the camera's screen. Use  to highlight Play, Stop, Rotate Left, or Rotate Right.

–Or–

5. Select the **Options** softkey. Choose from the following options:
 - **Send** launches the messaging application so you can share the videos.
 - **Record New** allows you to record new videos.
 - **Erase** the videos.
 - **Send to Online** uploads a video to a server.
 - **Rename** allows you to rename the video file.
 - **Details** gives you the file size of the video.
 - **Erase All** erases all videos stored.
6. Select the **Close** softkey when done.

Creating free space

If your phone does not have enough memory to store a file, a dialog displays and asks you if you want to create space. The softkeys are **Yes** and **No**.

- Pressing the **Yes** softkey displays the file browser (categories) with the memory needed and available memory.
- Pressing the **No** softkey returns to the previous screen and no files are saved or downloaded.

The softkey actions are limited to the following:

- **Erase** the selected file (you cannot erase locked files).
- **Done** re-attempts the download or save.

10 USING TOOLS

Voice Memo



The Voice Memo tool allows you to record and play back audio memos.

Recording a voice memo

Swivel closed



- Press and hold  in to activate voice memo.

Swivel open

1. Select **Menu** → **Tools** → **Voice Memo** → **Record New**. The phone says: “Please record at the tone.”
-or-
Press and hold  right to activate voice memo.
2. Say your memo and press to  select **Save**.

Note: If an incoming call is received while you’re recording a memo, the memo is saved and the incoming call screen displays.

Playing or reviewing a memo



1. Select **Menu** → **Tools** → **Voice Memo**.
2. Highlight the memo to review and press .
3. Press  to hear the memo.
4. Press the keys listed in the table to perform the following memo functions:

	Pause		Fast forward
	Stop	NAME	Name the memo
	Rewind	ERASE	Erase a memo

Naming a saved voice memo

1. Select **Menu** → **Tools** → **Voice Memo**.
2. Highlight the memo and press .
3. Select **Options** → **Name**.
4. Enter a name for the memo and select **Save**.

Erasing a saved voice memo









1. Select **Menu** → **Tools** → **Voice Memo**.
2. Highlight the memo to erase and press .
3. Select **Erase**. The prompt “Erase Memo?” appears.
4. Select **Yes** and press .

Scheduler







The Scheduler allows you to schedule events and set reminder alerts.

Creating an event

1. Select **Menu** → **Tools** → **Scheduler**.
2. Press  down to select **Add Event**.





3. Enter a name for the event. For help entering text, see page 16.
4. Press  to select **Next**.
5. Enter the time, length, and alarm for event.
 - Press  up or down to select hour, minutes, and timing of alarm.
 - Press  left or right to move between fields.
6. Press  to select **Next**, enter a note if required.
7. Press  to select **Done**.
8. Select the event's date and time:
 - Press  left and right to scroll through days and months.
 - Press  up or down to scroll through time.
9. Press .

Viewing, editing, or erasing an event

1. Select **Menu** → **Tools** → **Scheduler**.
2. Select **View Day** or **View Month** to find the event you want to view, edit, or erase.
3. Press  up, down, left, or right to highlight an event and press  to select it.
4. Press  right and press  to select **Edit**, **Erase**, or **New**. Follow the prompts.
5. Press  to return to the home screen or  to return to scheduler options.





Alarm Clock

Use the Alarm Clock to set an alert for a specific time. The alert occurs only if the phone is on.

1. Select **Menu** → **Tools** → **Alarm Clock**
2. Press  to select **Enable**.
 - Press  up or down to select an hour and minutes.
 - Press  left or right to switch between hours, minutes, and a.m./p.m.
 - Use the phone keypad to enter numbers.
3. Press  to select **Done** and save the setting.
4. When the alarm rings, select **Off** to turn off the alarm or **Snooze** to silence the alarm for 10 minutes.

Tip Calculator

The Tip Calculator helps you calculate how much tip to include on a bill.

1. Select **Menu** → **Tools** → **Tip Calculator**.
2. Enter the amount of your bill.
3. Press  to select **Next**.
4. Select the amount you want to include as a tip (10%, 15%, 18%, 20%, Other) and press . Your total bill appears, including tip.
5. To split the bill, press  to select **Split**.
6. Press  to clear the default of 2 guests.

- Enter the number of guests and press to select **Next**. The amount each guest pays is calculated.
- Press to select **Done**.

Calculator

Use the calculator for basic mathematical equations.

- Select **Menu** → **Tools** → **Calculator**.
- Use the keypad to enter numbers.
- Use to highlight mathematical operations.
- Press to calculate the result.

Example: Enter 5, press left to highlight **X**, enter 2, then press to obtain the result of 10.

- Press to return to the home screen.

Tip: Press to clear the screen.

Navigation:

= equal + add x multiply
 ÷ divide - subtract

Options softkey

- M+ Adds displayed digit to the value stored in memory.
- MR Displays currently stored value on screen.
- MC Clears value currently stored in memory.

Timer

This timer counts down for a specified amount of time. It beeps when that amount of time has elapsed.

- Select **Menu** → **Tools** → **Timer**.
- Press to select **Set**.
- Press up or down to set the hours, minutes, and seconds. To move the cursor, press left or right.
- Press to select **Start** and begin the countdown.
 Press to select **Stop** to pause the countdown.
- When the alarm rings, press to silence it.

Stopwatch

- Select **Menu** → **Tools** → **Stopwatch**.
- Press to select **Start** and have the stopwatch begin counting.
- Press to select **Stop** to stop counting.
- Press to select **Reset** to clear the counter.
- Press to return to the home screen.



11 FUN & GAMES

The games in this chapter may not be available on your phone. Check with your service provider for availability.

If you receive an **incoming call alert** while you are playing Tetris™ or Race 21™, the game is paused and exited. You can return to play once the call alert ends. Games do not remain paused if the phone is turned off or loses power.

Tetris

The goal of this game is to guide the falling blocks down the screen to create a solid horizontal row at the bottom. The game ends when the new block cannot enter the play field because the area is occupied by another block or obstacle.

1. Select **Menu** → **Fun & Games** → **Tetris**.
2. Press  at the splash screen.
3. Highlight an option and press  to select it.



















New Game—Initiates game play. To pause the game, press . You return to the menu where you can **Continue Game** or choose from other available options.

Resume Saved—Returns you to the game you were last playing.

Scoreboards—Displays the top five scores for the different game variations.

Settings—Choose a level of play, sounds, and game type.

Navigation: Use the following keys to guide the blocks down the screen:

To:	Use:
Rotate Counterclockwise	 ,  , or 
Rotate clockwise	 ,  ,  ,  ,  or 
Move left	 or 
Move right	 or 
Soft drop	 or 
Hard drop	
Return to Tetris menu	
Pause/End Pause	

Race 21

This game is a timed variation of Black Jack. Each game comprises three 90-second rounds. To score points, add cards in each of the four columns, trying to reach but not exceed 21 in each column within during the course of the game. To play:

1. Select **Menu** → **Fun & Games** → **Race 21**.
2. Press  at the splash screen.
3. Select **New Game**. The first card to be placed is shown at the top left of the screen. Press a key to add a card to the row as follows:

 Add cards to the first row

Add cards to the second row

Add cards to the third row

Add cards to the fourth row

Shortcut: Press left or right to choose arrows at the bottom of the screen. Then press to add cards to corresponding rows.

Note: Each time you place a card, a new card appears for placement.

- Continue placing cards until you are satisfied with your selections.
 - You can pause or end the game at any time by pressing .
 - You lose points each time you exceed 21 in a column.
 - Select **Skip** to skip one card per round.
- Press to select to get your score and advance to the next round.
- Select an option and press to select it.
 - New Game**—Initiates game play. To pause the game, press . From here you can choose **Resume**, **New** or **Quit**.
 - Resume Game**—Returns you to the game you were last playing.
 - Scoreboard**—Provides you with the top five scores.
 - Music**—Choose when you hear music with this game. Select from **Music Always**, **Sound Effects**, **Instructions**, **Credits**, **During Title**, or **No Music**.

- Press to end all games.

Doodler

You can create and save graphics on your phone.

- Select **Menu** → **Fun & Games** → **Doodler**.
- Press at the splash screen.
- Select **New Doodle** to open the drawing screen. The cursor is located in the middle of the screen.
- Select **Options** to choose the **Tools**, **Lines**, or **Shape** you want to use.
- Use keys 1–9 to move the cursor around the screen as indicated.
- When finished, select **Options** → **Save**. The image is saved to **My Pictures**.

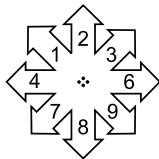

To move cursor away from drawing:

- Select **Options** → **Tools**.
- Select , then **Done**.
- Press a number key to move the cursor.

To erase part of drawing:

- Select **Options** → **Tools**.
- Select , then **Done**.
- Press a number key to move the eraser.

To Navigate: Use the following keys to doodle.

To:	Use:

Clear screen

Shortcut to Tools

Draw, erase, or move cursor/
shape UP

Draw, erase, or move cursor/
shape DOWN

Draw, erase, or move cursor/
shape LEFT

Draw, erase, or move cursor/
shape RIGHT

Return cursor to center

Previous screen



Saving a doodle

It is a good idea to save the doodle while you are working on it. If you receive a call while creating an unsaved doodle, it will be lost.

- Select **Options** → **Save** and press . The image will be saved in the **My Pictures** folder. (See page 58.)

Note: If you make changes to an existing doodle, you must save it with a different name.

Resuming a doodle

- To return to the last saved doodle you were working on, select **Menu** → **Fun & Games** → **Doodler** → **Resume Doodle**.
- To return to another saved doodle, select **Menu** → **Fun & Games** → **Doodler** → **Doodles**.

My Sounds

Your phone contains preset sounds, which you can add to outgoing text messages. Check with your service provider for availability.

To access stored sounds:

1. Select **Menu** → **Fun & Games** → **My Sounds**.
2. Press up or down to scroll through the sounds.
3. Highlight an option and press to select it:
 - **Play** allows you to listen to the sound.
 - **Send** opens a new message entry screen.
 - **Assign** allows you to use the sound as a ringer on your phone.
 - **Delete** erases the sound from your **My Sounds** list.

My Pictures

The My Pictures menu stores 25 graphics you have created using the Doodler or received via text messaging. It also includes predefined graphics for your use. Check with your service provider for availability.

Note: All downloaded graphics are also stored in the Screen Saver menu.

To view, edit, or erase graphics:

1. Select **Menu** → **Fun & Games** → **My Pictures**.
2. Press up or down to scroll through the graphics.

3. Highlight an option and press  to select it:
- **Send** opens a new message entry screen.
 - **Assign** sets your graphic as a screen saver.
 - **Edit** takes you to the Doodler, where you can modify the graphic. You cannot edit predefined graphics.
 - **Delete** erases the graphic from memory. The graphic is also erased from the Screen Saver menu. (You cannot delete predefined graphics that came with the phone.)
 - **Exit** returns you to the home screen.

Using the Web Browser

You can use your phone to browse the Internet if you have obtained phone Internet services from your service provider and if over-the-air Internet access is available in your area.

Note: You cannot receive incoming calls while you are using the Web Browser.

Starting the Web Browser

1. Select **Menu** → **Web Browser**.

A message about airtime fees appears every time you start the browser.

To cancel the message, see “Changing the Web prompt” on page 61.

For more information about how airtime is charged, contact your service provider.



2. Press to continue.

If this is the first time you have connected to the Internet, a message informs you that security is not yet enabled for your Web Browser.

3. Press to select **Yes** to enable security.

When you are connected, a browser home page appears. It has a list of bookmarks and some Web menu options at the bottom of the screen.

- A  appears in a secure session.

- An underline and an arrow indicate that there is more text. Press  down to view more text. Press  to return to the previous screen.
- To choose a site, highlight it and press  to select **Go**.

4. When you have finished using the Internet, press to exit the browser.

Using the Web menu options

The following options may appear on your screen:

- **Home** returns you to the main Web Browser window, or home page.
- **Mark Site** saves the current location as a bookmark for easy access.
- **Bookmarks** displays a list of your saved Web sites.
- **Setup** gives you options for changing how information is displayed.
 - **Show URL** displays the entire URL.
 - **About Openwave** displays information about your Web Browser version.
 - **Encryption** should not be used unless you are instructed to do so by your service provider.



- **UP.Link** selects a different browser server. You can use this option if you have more than one Web Browser account.
- **Restart** restarts the Web Browser.

- **At Start** confirms that airtime fees will be applied when you use the browser.
- **At End** verifies you want to exit the browser.
- **Both** prompts you when you start the browser and exit the browser.
- **No Prompts** does not use any prompts.

Searching for a Web site

How you search for a Web site depends on your service provider. For more information, contact your service provider.

Going to a bookmarked site

1. Select **Menu** → **Web Browser**. If you see a message prompt, press  to continue.
2. From your Web home page, select **Bookmarks**. A list of bookmarks appears.
3. Enter the number corresponding to the bookmark you want and press .

Checking Net alerts

Alerts received from a Web site are sent to your **Net Alerts** inbox.

1. Select **Menu** → **Messages** → **Net Alerts**. This action launches the browser inbox.
2. Press  to accept browser fees.
3. Select an alert and follow the prompts.

Changing the Web prompt

1. Select **Menu** → **Settings** → **Convenience** → **Web Prompt**.
2. Highlight an option and press  to select it:

13 GETTING HELP

Customer support

Your service provider's customer support department may be accessible directly from your phone when you dial a number such as *611 (check with your service provider). They can answer questions about your phone, phone bill, call coverage area, and specific features available to you, such as call forwarding or voicemail.

For questions about the phone features, refer to the materials provided with your phone, or visit www.kyocera-wireless.com.

For additional questions, you may contact the Kyocera Wireless Corp. Customer Care Center in any of the following ways:

- Web site: www.kyocera-wireless.com
- Email: phone-help@kyocera-wireless.com

Before requesting support, please try to reproduce and isolate the problem. When you contact the Customer Care Center, be ready to provide the following information:

- The name of your service provider.
- The actual error message or problem you are experiencing.
- The steps you took to reproduce the problem.
- The phone's electronic serial number (ESN).

- To locate the ESN select **Menu** → **Phone Info** and scroll down to ESN: for the 11-digit number.

Phone accessories

To shop for Koi phone accessories, visit www.kyocera-wireless.com/store. You may also call us at (800) 349-4188 (U.S.A. only) or (858) 882-1410.

Become a product evaluator

To participate in the testing and evaluation of Kyocera Wireless Corp. phone products, visit beta.kyocera-wireless.com.

INDEX

Numerics

1-Touch dialing, 12

A

Alarm Clock, 8, 54

alerts

for messages, 32

for missed calls, 11

analog mode, 8

auto-hyphenation, 34

AutoText, 23, 28

B

banner, 33

battery, 1

blocking outgoing calls, 36

C

Calculator, 55

call counters, 14

callback number, 23

calls

answering, 10

ending, 9

ignoring, 10

missed, 11

redialing, 9

silencing, 10

camera

menu options, 45

recording video, 48

sending a picture, 47

setting up, 42

taking a picture, 42

color themes, 35

Com Port speed, 37

Contacts directory, 19

contrast, 34

countdown timer, 55

custom menu

creating, 33

updating, 33

D

data/fax setup, 14, 37

digital mode, 8

Direct View, 25

display contrast, 34

Doodler, 57

E

emergency

calls, 13

emergency mode, 13

exit emergency mode, 13

position location, 8, 38

erasing

contact entries, 36

text messages, 26

F

Fast Find, 21

fax mode, 37

finding a saved phone number, 21

flip

answering calls, 10

frequent contacts, 21

G

games

Doodler, 57

Race 21, 56

Tetris, 56

H

hands-free car kit

answering using voice, 41

purchasing, v, 62

hands-free headset

purchasing, v, 62

hard pause, 19

I

icons, 8

InBox, 26

K

Kilobyte timer, 14

L

language, 33

lights

lights-only mode, 8, 30

limiting calls out, 36

lock code, 35

locking

phone, 36

M

memory, saving, 26

menu view, 33

N

number mode, 16

O

OutBox, 24

P

phone book (Contacts directory),

19

- phone numbers
 - editing, 20
 - finding, 21
 - saving, 19
 - verifying your own, 7

- phone, unlocking, 36
- position location, 8, 38
- power save mode, 9
- prepend, 11, 20

R

- Race 21, 56
- recent call icons, 11
- resetting the phone, v
- ringers
 - choosing types, 30
 - for roaming calls, 15
 - silencing, 7
 - volume, 32
- roaming, 8

- alerts, 14
- controlling, 14
- ringer, 15

S

- saved phone numbers
 - editing, 20
 - finding, 21
- Scheduler, 53
- screen contrast, 34
- screen icons, 8, 16, 25, 30, 41
- screen savers, 35
- secret contacts, 11
- security, 35
- silent mode, 8, 30
- sound files, 58
- speakerphone
 - turning off, 10

- turning on, 10
- speed dialing, 12
- Stopwatch, 55
- symbol mode, 17

T

- technical support, v, 62
- Tetris, 56
- text entry, 16
 - quick reference, 18
- text messages, 22
- time format, 35
- Timer, 55
- timing calls, 14
- Tip Calculator, 54
- TTY/TDD, 38

U

- unlocking the phone, 36

V

- vibrate, 8, 30
- Voice Answer, 41
- voice dialing, 39
- voice memo
 - erasing, 53
 - naming, 53
 - recording, 53
- voicemail, 12, 13
 - setting up, 7
- volume
 - earpiece, 13, 31
 - key beep, 32
 - ringer, 32

W

- wallpaper, 35
- Web Browser, 60



Draft Copy!

82-K5770-1EN, Rev. X5

KYOCERA WIRELESS CORP.
10300 CAMPUS POINT DRIVE
SAN DIEGO, CALIFORNIA 92121 USA
www.kyocera-wireless.com