

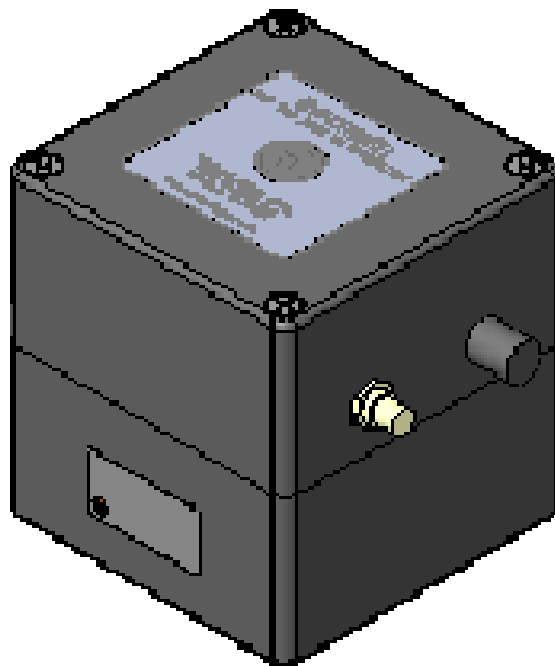

communications

# L-3 COMMUNICATIONS AID TO NAVIGATION (AtoN) INSTALLATION & OPERATION MANUAL



## AtoN PART NUMBERS:

ATN01-100-00  
ATN01-100-01  
ATN01-100-02  
ATN01-100-03  
ATN01-300-00  
ATN01-300-01  
ATN01-300-02  
ATN01-300-03  
ATN01-301-00



communications

Aviation Recorders

Marine Systems

AtoN Installation & Operation Manual

**L-3 AtoN I&O Manual 165M0829-00**

**Rev. 7**

**August 7/08**

**EXPORT CONTROL STATEMENT AIS TECHNOLOGY / DATA:**

**“This technical data is controlled under the Export Administration Regulations ECCN 5E992, and may not be exported to a Foreign Person, either in the U.S. or abroad, without the proper authorization of the U.S. Department of Commerce.”**

**This manual contains date sensitive information. To verify the latest revision level of this manual, visit our document download site at <http://www.L-3ar.net>.**

**©Copyright 2008 by L-3 Communications.**

**All rights reserved. No part of this manual may be reproduced or utilized in any form or by any means, electronic or mechanical, including photocopying, recording, or by information storage and retrieval system, without permission in writing.**

**Inquiries should be addressed to:**

**L-3 Communications**

**Aviation Recorders Publications**

**Vendor Code: 06141**

**P. O. Box 3041**

**Sarasota, Florida 34230**



communications

Aviation Recorders

Marine Systems

AtoN Installation & Operation Manual



## GENERAL

**This product and related documentation must be reviewed for familiarization with safety markings and instructions before operation.**

*This board was constructed in an ESD (electro-static discharge) protected environment. This is because most of the semiconductor devices used in this board are susceptible to damage by static discharge.*

*Depending on the magnitude of the charge, device substrates can be punctured or destroyed by contact or mere proximity of a static charge. The results can cause degradation of device performance, early failure, or immediate destruction.*

*These charges are generated in numerous ways such as simple contact, separation of materials, and normal motions of persons working with static sensitive devices.*

*When handling or servicing equipment containing static sensitive devices, adequate precautions must be taken to prevent device damage or destruction.*

*Only those who are thoroughly familiar with industry accepted techniques for handling static sensitive devices should attempt to service circuitry with these devices.*

*In all instances, measures must be taken to prevent static charge build-up on work surfaces and persons handling the devices.*



communications

---

Aviation Recorders

Marine Systems

AtoN Installation & Operation Manual

*THIS PAGE IS INTENTIONALLY LEFT BLANK.*



communications

Aviation Recorders

Marine Systems

## **AtoN Introduction**

### **1.1. General**

The Aids to Navigation (AtoN) is an Automatic Identification System (AIS) transmitter that is fully compliant to the technical specifications defined by the IMO and outlined in ITU.R.M 1371-1. The transmitter is designed to be installed in weather and navigation buoys with no periodic maintenance required. The transmitter employs the latest radio frequency and FATDMA technology to provide a high performance, automated, and reliable identification system. The transmitter is a fully automated system, which ties into the buoy's navigational and/or weather monitoring instrumentation to provide automatic transmission of navigational and meteorological data (dependent on the installation).

The Transponder is a fully automated system. This means that once it is installed and turned on, no maintenance is required to keep it operational.

The L-3 ProTec Inland Waterways/Class A Automatic Identification System transponder is manufactured in Sarasota, Florida, United States of America, pursuant to ISO 9000.

#### **1.1.1. System Overview**

The AtoN is an Aids to Navigation System fully compliant with the IMO specifications defined in IMO MSC.74(69) Annex 3, IEC 62320-2-2, and ITU.R M.1371-3. With the addition of the FATDMA controllers, the AtoN provides a cost-effective AIS solution, which will meet the needs of any waterway required to transmit AtoN data. The compact, single-box design allows the AtoN to be easily incorporated into any buoy layout thus simplifying installation and cabling requirements.

The AtoN has been designed as maintenance-free unit, which makes extensive use of surface mount technology (SMT). The repair of printed wiring assemblies (PWAs) containing SMT components requires specialized factory equipment, training, and techniques, therefore, such PWAs are not field-repairable.

As a result, maintenance philosophy for the AtoN is replacement of failed assemblies. In the case of the AtoN, the entire unit should be sent back to the factory, in the unlikely case of a failure.

Attempts by anyone but an authorized L-3 representative to repair the AtoN will void the warranty.



communications

**Aviation Recorders  
Marine Systems**

**For repair service, call or email to obtain an RMA # or Form:**

L-3 Communications, Aviation Recorders  
6000 E. Fruitville Road  
Sarasota, FL 34232 USA  
Attn: Repair Department  
Tel: (941) 377-5558  
Fax #: (941) 377-5585

**1.1.2. References**

IMO Resolution MSC.74(69), Annex 3, Recommendation on Performance Standards for a Universal Shipborne Automatic Identification Systems (AIS)

International Telecommunications Union Sector for Radio Communications (ITU-R) Recommendation M.1371-3, Technical Characteristics for a Universal Shipborne Automatic Identification System Using Time Division Multiple Access in the Maritime Mobile Band.

IEC 61993-2 Edition1, Maritime Navigation and Radio communication Requirements - Automatic Identification Systems (AIS) - Part 2: Class A shipborne Equipment of the Universal Automatic Identification System (AIS) - Operational and Performance Requirements, Methods of Test and Required Test Results

IEC 60945 Edition 4, Maritime Navigation and Radio communication Equipment and Systems - General Requirements - Methods of Testing and Required Test Results.

IALA Recommendation on AIS Shore Stations and Networking Aspects Relating to the AIS Service, Edition 1.0, September 5, 2002

IEC 61162-1 Edition 1.0, Maritime Navigation and Radio communication Equipment and Systems - Digital Interfaces - Part 100: Single Talker and Multiple Listeners

IEC 61162-2 Edition 1.0, Maritime Navigation and Radio communication Equipment and Systems - Digital Interfaces - Part 100: Single Talker and Multiple Listeners, High-Speed Transmissions

**1.1.3. Acronyms**

ABM	Addressed Binary Message
ABK	Acknowledgment Message
ACA	AIS Channel Assignment
ACK	Acknowledgment Message
ARM	Advanced RISC Machine
ARPA	Automatic Radar Plotting Aid
BBM	Broadcast Binary Message
COG	Course Over Ground
DGPS	Differential Global Positioning System
DSP	Digital Signal Processor



communications

**Aviation Recorders**

**Marine Systems**

FATDMA	Fixed Access Time Division Multiple Access
GGA	Global Positioning Fix Data
GLL	Geographic Position, Latitude/Longitude
GNSS	Global Navigation Satellite System
GPS	Global Positioning System
GSA	GPS DOP and Active Satellites
GSV	GPS Satellites in View
HDG	Heading, Deviation & Variation
HDT	Heading, True
IEC	International Electrotechnical Commission
IMO	International Maritime Organization
LRF	Long Range Function
LFI	Long Range Interrogation
MMSI	Maritime Mobile Service ID
NMEA	National Marine Electronics Association
NV	Non-Volatile
PLL	Phase Locked Loop
RAIM	Receiver Autonomous Integrity Monitoring
RATDMA	Random Access Time Division Multiple Access
RF	Radio Frequency
RMC	Recommended Minimum Data for GPS
ROT	Rate of Turn
SOG	Speed Over Ground
SOTDMA	Self Organized Time Division Multiple Access
SSD	Station Static Data
TDS	Target Display Software
TXT	Status/Indication Message
VBW	Dual Ground/Water Speed
VDL	VHF Data-link Other Vessel Message
VDM	VHF Data-link Message
VDO	VHF Data-link Own-vessel Message
VSD	Voyage Static Data
VSWR	Voltage Standing Wave Ratio
VTG	Track Made Good and Ground Speed
ZDA	Date and Time



communications

Aviation Recorders

Marine Systems

## 1.2. Technical Specifications

**Standards** IMO MSC.74(69) Annex 3, IEC 61993-2 Ed. 1, ITU.R.M.1371-1, IALA A-126

### **TDMA Transmitter**

TX Frequency: 156.025 MHz - 162.025 MHz

Transmitter Power: 12.5 W max.

Channel Bandwidth: 25 kHz

### **Output**

Message 6, Message 21 as defined in ITU.R.M.1371-1

### **Power Supply**

12 VDC nominal

### **Power Consumption**

Message 21 (FA) every 3 minutes for 30 minutes (10 full cycles):

- Average Instantaneous Current: 14.2 mA ( $V_{in} = 12.0$  Vdc)
- Average Instantaneous Power: 170 mW

Message 21 (RA) every 3 minutes for 30 minutes (10 full cycles):

- Average Instantaneous Current: 125 mA ( $V_{in} = 12.0$  Vdc)
- Average Instantaneous Power: 1500 mW

Power usage in continuous receive mode:

- Average Instantaneous Current: 323 mA ( $V_{in} = 12.0$  Vdc)
- Average Instantaneous Power: 3880 mW

### **Environment**

IEC 60945 Ed. 4 for Unprotected Environment

### **Frequency**

VHF Marine Band





communications

Aviation Recorders

Marine Systems

### 1.3. AtoN Description

#### 1.3.1. Compact Design

The completely self-contained L-3 AtoN has outside dimensions of 5.24" W (133 mm.) x 4.73" H (120 mm.) x 4.73" D (120 mm.). It is easily mounted inside the buoy using a flush-mount bracket.

## MODEL ATON AIS FOR AIDS TO NAVIGATION SYSTEMS PART NUMBER MATRIX

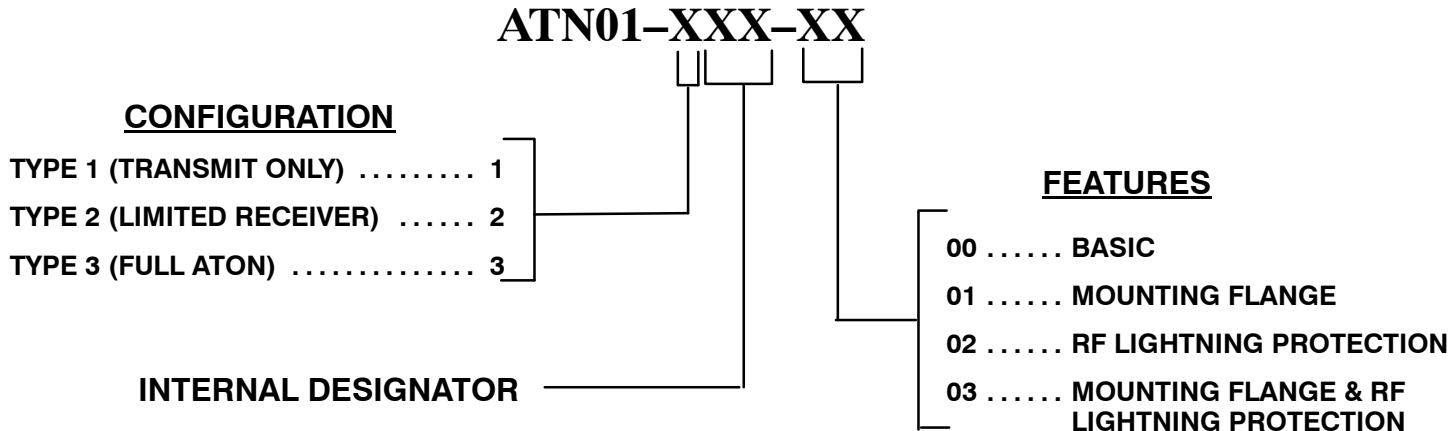

Figure 1-1. AtoN Part Number Matrix



communications

---

**Aviation Recorders  
Marine Systems**

*THIS PAGE IS INTENTIONALLY LEFT BLANK.*



communications

Aviation Recorders  
Marine Systems  
Automatic Identification System

## AtoN Mounting & Connections

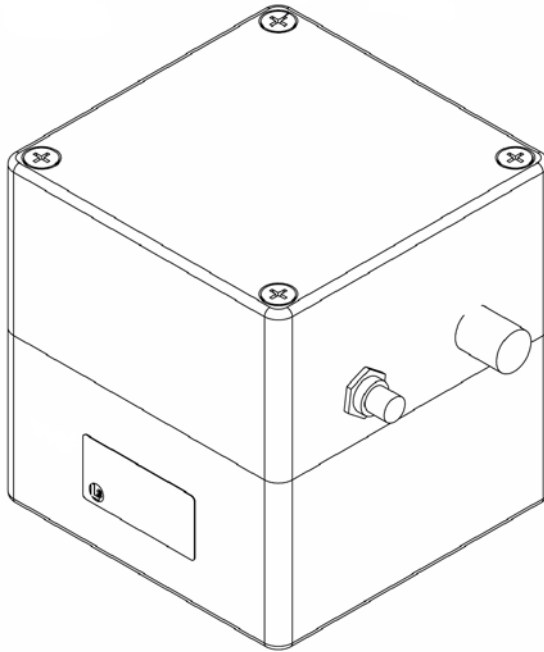

**ISOMETRIC VIEW  
PART NUMBERS:**

ATN01-1-00-00  
ATN01-1-00-02  
ATN01-3-00-00  
ATN01-3-00-02  
ATN01-3-01-00

**Figure 2-1. AtoN**

**ISOMETRIC VIEW  
PART NUMBERS:**

ATN01-1-00-01  
ATN01-1-00-03  
ATN01-3-00-01  
ATN01-3-00-03

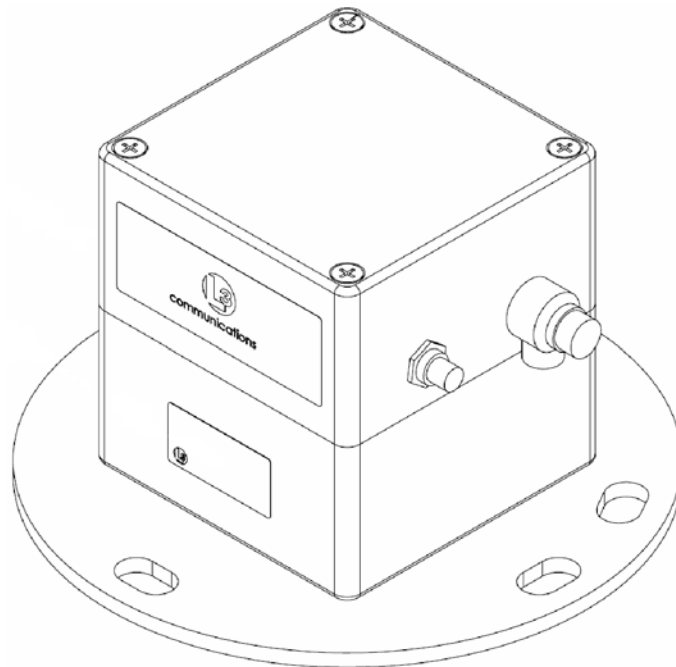
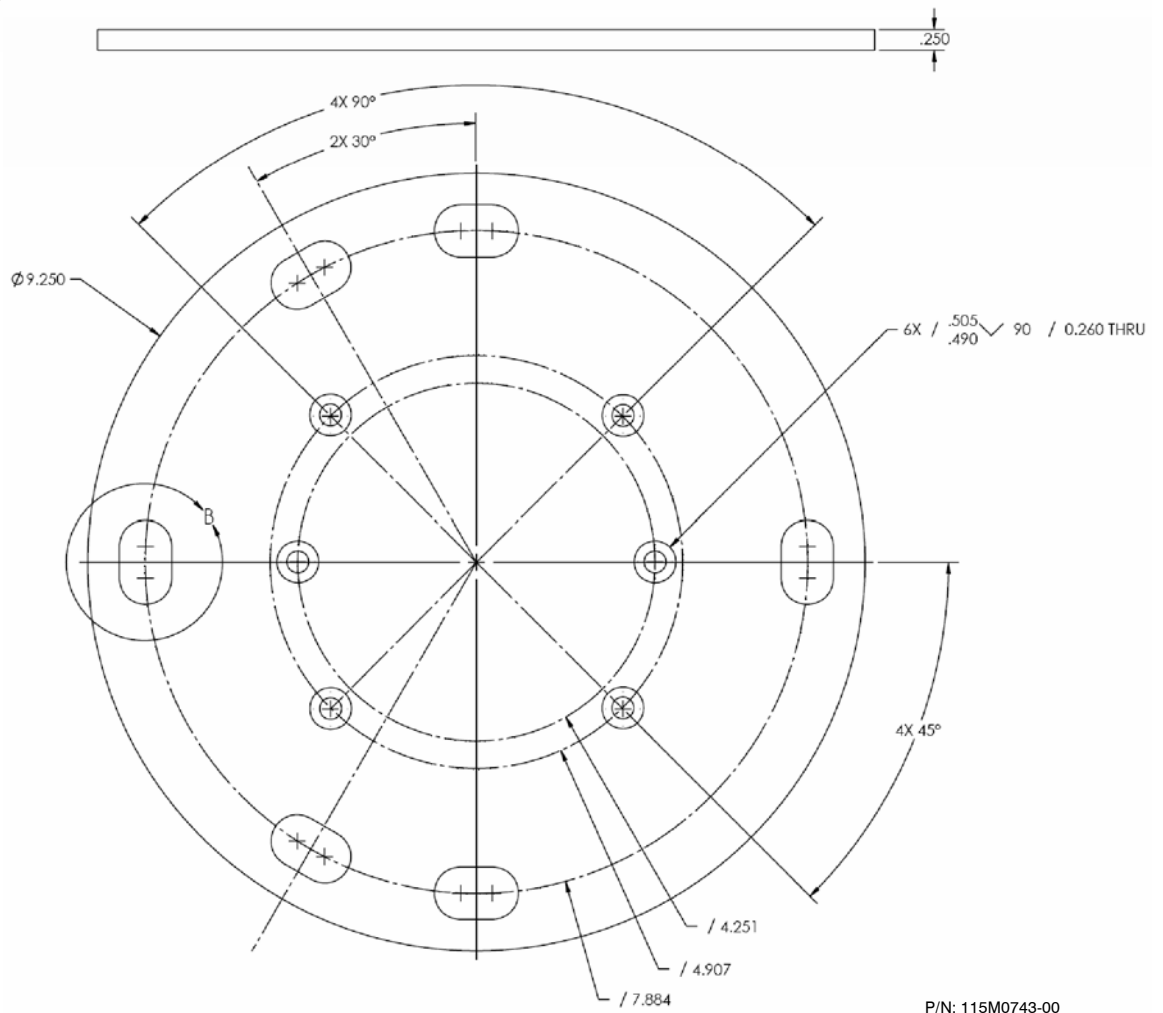
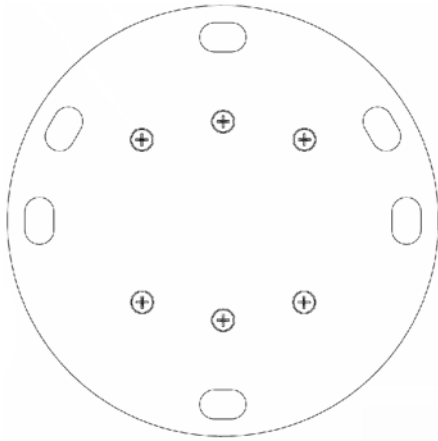

**Figure 2-2. AtoN with Mounting Plate**



communications

**Aviation Recorders  
Marine Systems  
Automatic Identification System**



P/N: 115M0743-00

**Figure 2-3. AtoN Mounting Plate  
Dimensions and Mounting Hole Pattern**



communications

**Aviation Recorders  
Marine Systems  
Automatic Identification System**

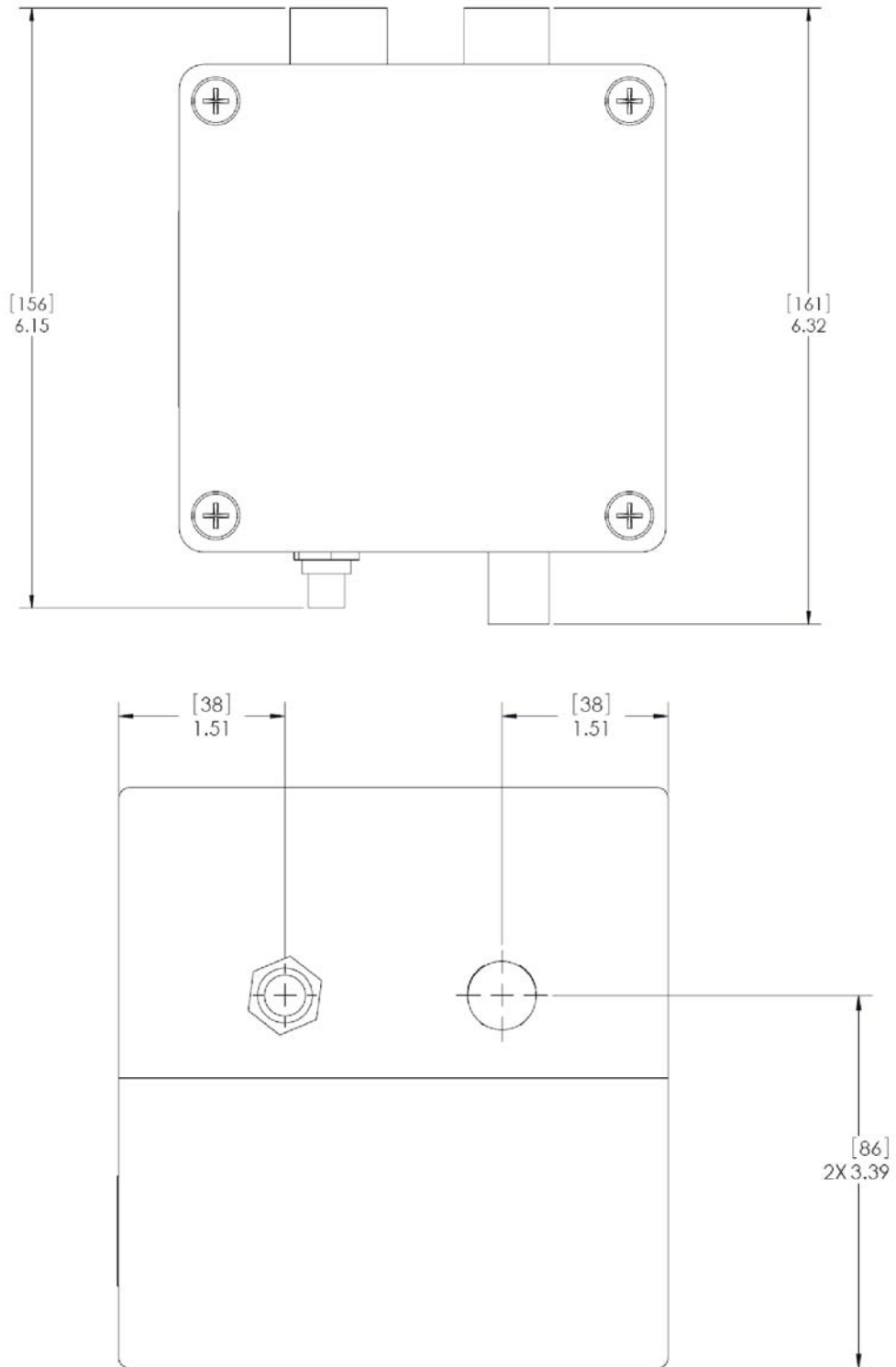
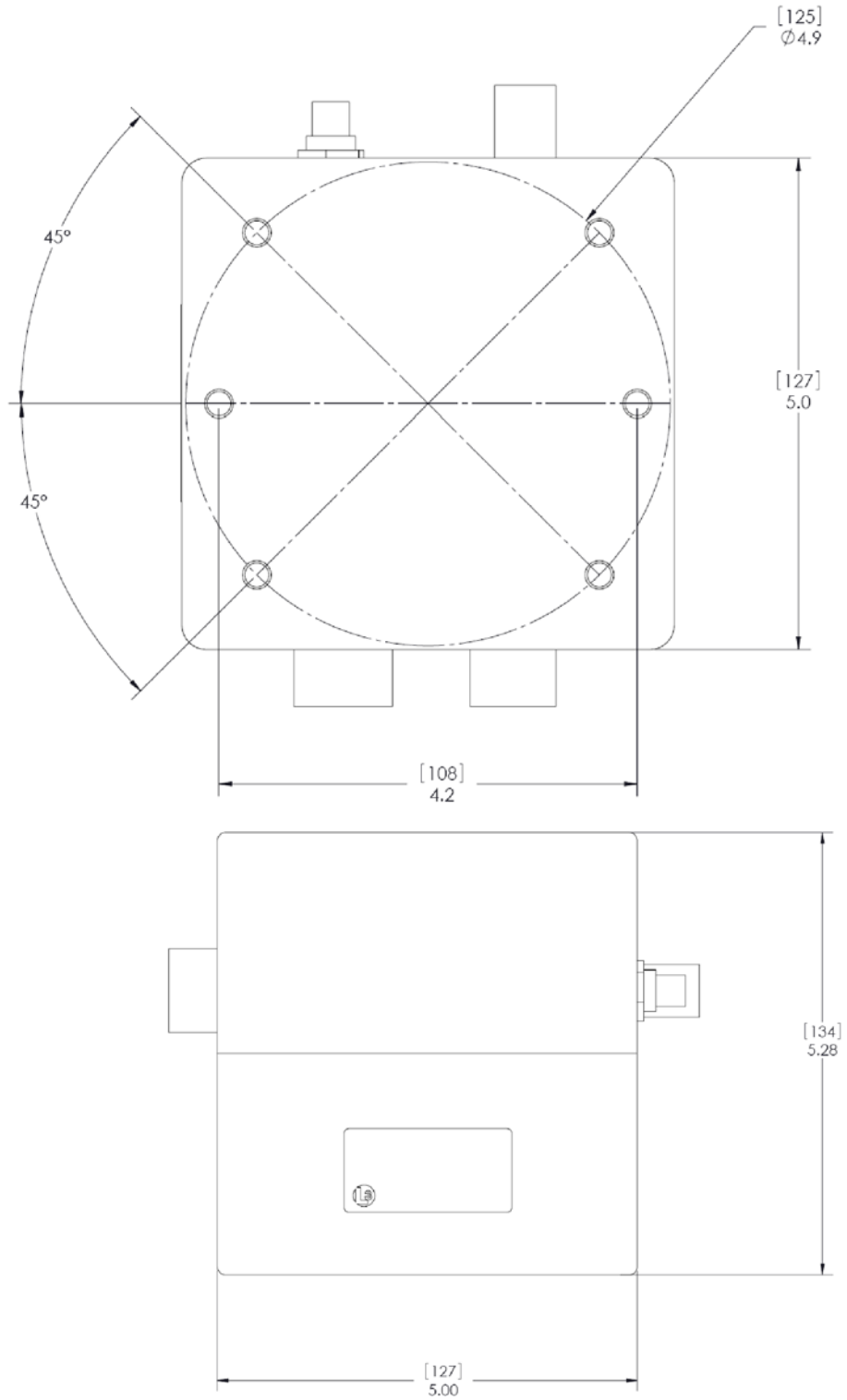

**Figure 2-4. AtoN Outline & Dimensions**



communications

**Aviation Recorders  
Marine Systems  
Automatic Identification System**

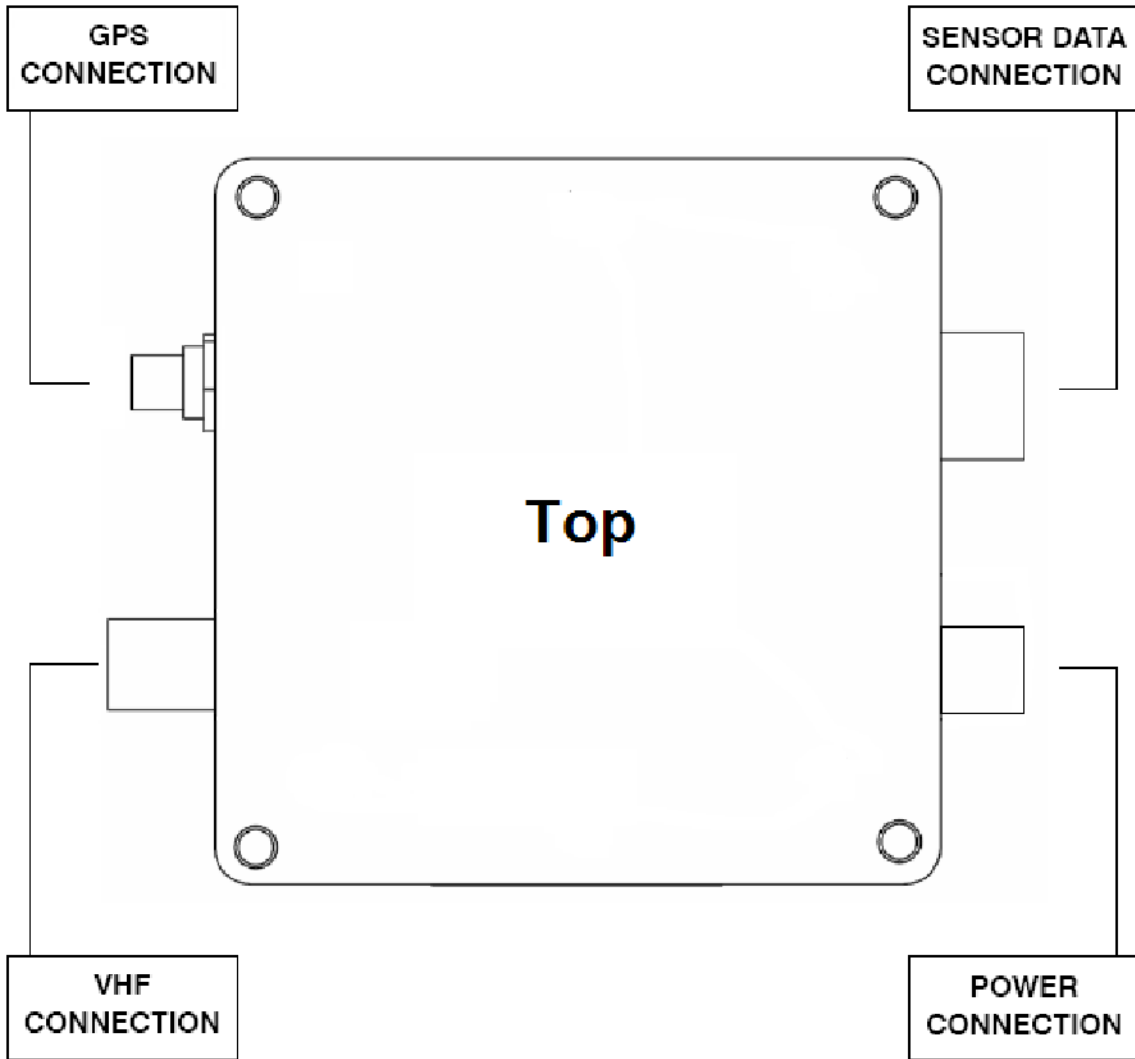

**Figure 2-4. (Continued) AtoN Outline & Dimensions**



communications

**Aviation Recorders  
Marine Systems  
Automatic Identification System**

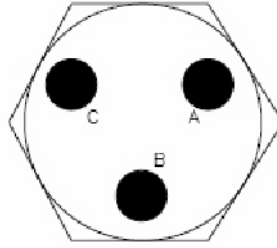

**Figure 2-5. AtoN Connections**



communications

**Aviation Recorders  
Marine Systems  
Automatic Identification System**



The power cable, Part Number 024M0926-00, is supplied by L-3.

SIGNAL		COLOR
+V	A	RED
CHASSIS	B	GREEN
+V RT	C	BLACK

**Figure 2-6. Power Connection Pin Out**

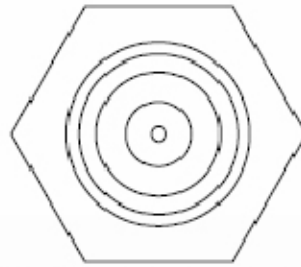

**Figure 2-7. GPS Connection Pin Out**

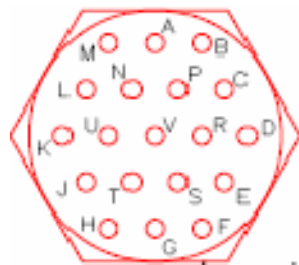

PIN	CONNECT
P	GND*
V	RSVD
U	RSVD
R	GND
L	RSVD
K	RSVD
G	RSVD
T	IEC-TX*
S	IEC-RX*
A	SYNC+
B	SYNC-

**Figure 2-8. Sensor Data Connection Pin Out\*\***

The Sensor Data cable, Part Number 024M0841-00, is supplied by L-3.

\*Used to connect to the AtoN IEC/serial port to a DB9 connector





communications

**Aviation Recorders  
Marine Systems  
Automatic Identification System**

\*\*Signals names are with respect to the AtoN (RS-232).

## **Installing the VHF Antenna**

Installation of a VHF antenna is as important to reliable communications as the transceiver itself. It is recommended that a high quality antenna be purchased from an established source and that all manufacturer's instructions be followed with particular attention to cable routing and connector installation. Some important considerations in antenna installation are:

- In general, VHF antennas should be located as high as practical on the buoy and separated as much as possible from each other.
- The VHF antenna should be placed in an elevated position with a minimum of 2 meters clearance from any construction that is made with conductive material. In addition, it should not be installed close to any large vertical obstruction, and the VHF antenna should have a 360° line of sight to the horizon.

**To install the VHF antenna, perform the following:**

(Refer to Figure 2-9.)

- (1) Position the antenna mounting bracket on a rigid and structurally sound surface.
- (2) Install the antenna on the antenna mount.

**NOTE: Use only high quality RG213/RG214 coaxial cable and keep cable length as short as possible to reduce signal attenuation.**

- (3) Run the coaxial cable from the antenna to the transponder location.
- (4) Trim cable to length leaving a few inches slack at the transponder.
- (5) Attach the connectors to the end of the coaxial cable.
- (6) Connect the cables to the transponder. Soldering the connection is recommended.



communications

**Aviation Recorders  
Marine Systems  
Automatic Identification System**

## **Installing the GPS Antenna**

The correct installation of a GPS antenna is crucial to the operation of the transponder because the internal transmission synchronization relies on the accuracy of the time signal obtained from the GPS. It is recommended that a high quality GPS antenna be purchased from an established source and that all manufacturer's instructions be followed with particular attention to cable routing and connector installation. Some important considerations in GPS antenna installation are:

- GPS antennas should be located to provide a clear, unobstructed view of the sky.
- GPS signals can also be affected negatively by VHF transmissions, and the GPS antenna should be positioned at least 3 meters from the VHF antenna, if possible.
- The GPS antennas can be flat mounted onto any surface but it is recommended that it be elevated as high as possible to prevent ice or spray from negatively impacting the signal reception.

### **To install the GPS antenna, perform the following:**

(Refer to Figure 2-9)

- (1) Position the antenna mounting bracket and/or antenna mast on a rigid and structurally sound surface.
- (2) Install the antenna on the antenna mount.

**NOTE: Use only high quality RG213/RG214 coaxial cable and keep cable length as short as possible to reduce signal attenuation.**

- (3) Run the coaxial cable from the antenna to the transponder location through an existing throughhull.
- (4) Trim cable to length leaving a few inches slack at the transponder.
- (5) Attach the connectors to the end of the coaxial cable.
- (6) Connect the cable to the transponder. Soldering the connection is recommended.



communications

**Aviation Recorders  
Marine Systems  
Automatic Identification System**

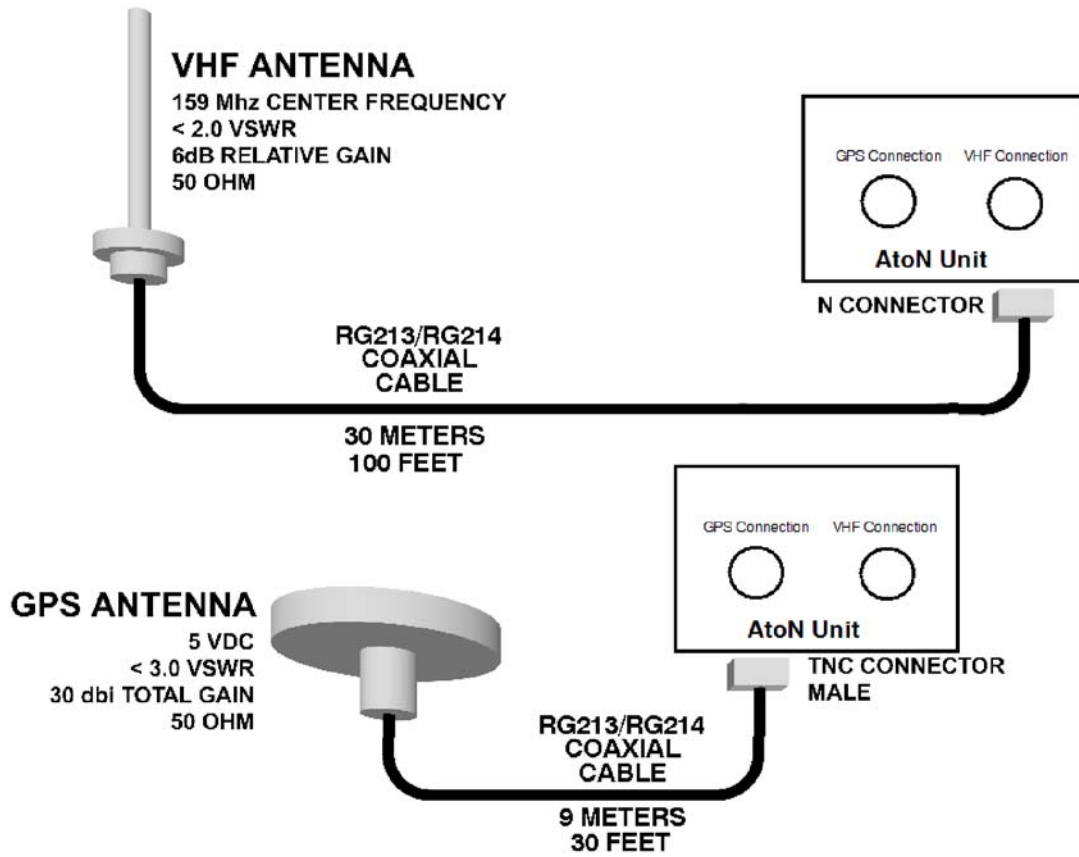

**Figure 2-9. AtoN Transponder Antenna Diagram**



communications

**Aviation Recorders  
Marine Systems  
Automatic Identification System**

*THIS PAGE IS INTENTIONALLY LEFT BLANK.*



communications

Aviation Recorders

Marine Systems

## **AtoN Configuration**

### **3.1. Introduction**

The AtoN may transmit messages 6 and/or 21 as specified by ITU-R M. 1371-1.

Message 6 is defined as an **Addressed Binary Message (ABM)**. It can be variable in length depending on the amount of binary data and can consist of 1 to 5 slots. Data from a message 6 may contain a status report on the health of the buoy, or other information. As implied in the name, the message must be addressed. That is, it must contain the appropriate destination MMSI of the base station that is to receive the transmission.

Message 21 is defined as an **Aids-to-Navigation Report**. This message is usually transmitted every 3 minutes and contains the origination MMSI, name of the AtoN (if applicable), type of AtoN (fixed or floating), position of the AtoN and the positional accuracy. The position information is derived from the on-board GPS receiver that is internal to the AtoN. As well as the deriving position, the GPS receiver is used as the basis for all transmission timing on the VDL. Unlike the message 6, this report is meant to be seen by all AIS transponders.

### **3.2. Configuration**

The transmit functions of the AtoN must be configured prior to installation. The configuration parameters specify what messages are transmitted over the air, how often the transmissions occur and what slot on the VHF data link (VDL) they are transmitted on.

**NOTE: All message assignments and intervals must be defined and approved by the appropriate competent authority where the AtoN is to be installed.**

Configuration is accomplished via a personal computer (PC) using a simple terminal emulator. An AtoN configuration cable is connected from the PC's serial port to the serial interface connector of the AtoN. In this example, Windows™ HyperTerminal is used. Connect the PC to the AtoN using the configuration cable.

### **3.3. Firmware Update**

In order to update AtoN firmware, the following is required:

- Power Cable: For details on the pin out, refer to Figure 2-6.
- Communications Cable: For details on the pin out, refer to Figure 2-8.



- Firmware Update Package

### 3.4. Overview

The AtoN contains two processors, an ARM and a DSP. The ARM has complete control over the DSP power and reset lines. The DSP runs the RF subsystem, but only when the ARM has enabled it to do so.

When the AtoN is up and running, the ARM Debug Unit (DBGU) serial port is used for Trace message output and shows ARM operational status and information. This interface also functions as a menu-based configuration and command and control channel for the unit, with a set of built-in “hot key” sequences for initiating various operations. The interface to this channel is typically a serial console program such as HyperTerminal. The ARM DBGU channel runs at 115200 Baud, 8 Data Bits, and No Parity.

**NOTE:** The AtoN’s sleep state may interfere with the configuration process.

When left unattended, the AtoN unit may go into a “sleep” state (enter Standby Mode). As of Rev 1.14H of the ARM software, this is the case for both Type 1 and Type 3 units. Standby Mode can interfere with running tests, loading code and configuring the AtoN unit. The AtoN can be prevented from entering Standby Mode by leaving the GPS antenna disconnected. The AtoN will not enter standby mode if it has no time input that the GPS would normally provide.

As of Rev 1.14H of the ARM software, the “Standby Enable” can be toggled on and off using the ^P^P sequence (Ctrl Key with P, twice) at the ARM console interface.

In order to run tests on the RF subsystem it is necessary that the DSP be powered up and released from Reset. This is completely under control of the ARM processor, making it impossible to run tests on the DSP unless the ARM is cooperating. Use the “T-2-E” sequence at the ARM console to ensure that the DSP is running.

The ARM DBGU serial interface also provides some user control in the form of Menu and command entry. There are three menus currently implemented, a System Configuration Menu, a General Configuration Menu and a Test Menu.

The System Configuration Menu is invoked by typing ‘S’, the General Configuration Menu is invoked by typing ‘C’, and the Test Menu is invoked by typing ‘T’.

On entry to any of these Menus, normal AtoN operation is terminated. Since the operations available in the Setup, Test and Config menus can leave the AtoN in an indeterminate state, a Reboot always follows the exit from these menus. This is automatic upon termination of Menu activity. The operations associated with these Menus are discussed further in subsequent sections of this document.



### Failure Modes

For Transmission Fault/Disabled Antenna:

A disabled antenna is detected by the AtoN DSP as an antenna with a high VSWR during the transmission of a message. If a high VSWR is detected, the DSP stops transmission before a message completes transmission.

For Reception Fault:

The AtoN uses a frequency synthesizer incorporating a digital PLL. If both receivers are locked, a Lock Detect status signal is sent indicating the receivers are functioning. If either or both receivers fail to lock then the Lock Detect status indicates a fault and RATDMA transmissions are stopped.

### 3.5. Resetting the AtoN from the ARM HyperTerm Console

When the AtoN is operational and Trace messages are being displayed on the ARM HyperTerm console, the unit can be Reset at any time by holding the Ctrl key and typing a pair of 'C' characters in succession. This avoids the need to cycle power in order to restart the AtoN.

### 3.6. ARM Code Update

If the Baseband Board has not been updated, it may still be loaded with Micromonitor in Flash. In this case, the ARM code must be updated as a first step. In order to do this, please follow the procedure below.

**NOTE:** Note that this method of updating the ARM code will work whether Micromonitor is in Flash or not. However, it is the only method that will work for loading an ARM standalone binary image if Micromonitor is still resident.

- (7) The ARM DBGU port should be connected to HyperTerm at 115200 Baud.
- (8) The BMS jumper must be installed on the Baseband Board, and power applied. The BMS jumper is installed on the Baseband Board at PL10, between pins 13 and 14.
- (9) If the BMS jumper connection is made, and power is applied to the AtoN, the HyperTerm console should display 'C' characters at approximately one per second.

Once the 'C' characters are being displayed at the HyperTerm console, the ARM code update can begin.

- (10) On the HyperTerm menu pull-down bar, select Transfer->Send File.



- (11) In the Protocol box of the subsequent pop-up window, select Xmodem.
- (12) Use the “Browse” button to locate the ARM binary images. Typically, these are contained in a folder called “Aton Images”. Select the “SerBoot.bin” file by double-clicking on it in the file list (or single-click and hit the “Open” button).
- (13) Hit the “Send” button in the “Send File” window. This will start the transfer.
- (14) On completion of the transfer the ‘C’ characters will start again. At this time, locate the ARM executable binary image in the same folder as the “SerBoot.bin” file. An example would be AtoN\_1\_03.bin. This name corresponds to Rev 1.03 of the ARM code. Typically, one would select the file with the highest version number, but there may be situations where an older version is to be loaded. Note that the Micromonitor image could also be sent at this point instead of the AtoN binary image. The Micromonitor image is contained in a file named “CSB\_637.bin” and represents the original Micromonitor image as contained on the Cogent CSB637 development boards that preceded the Baseband board.
- (15) Select the binary file to be loaded by double-clicking on it in the file list (or single-click and hit the “Open” button).
- (16) Next hit the “Send” button in the “Send File” window. This will start the transfer of the binary image.
- (17) On completion of the transfer the ‘C’ characters will start again. Remove the BMS jumper and power the board up again. The unit should boot normally and Trace messages will appear in the HyperTerm window. Note that if an ARM standalone image was loaded, the HyperTerm connection must be at 115200 Baud (the same as the download). However, if the Micromonitor image was restored for some reason (not typical) the HyperTerm connection must be set to 38400 Baud.

### **3.7. Clearing the NV Content**

Some situations may require the entire NV configuration be cleared. This is a recommended procedure when an ARM software update is performed because the stored NV configuration structures may not be compatible with the code that has been loaded.

Clearing the NV content does not cause the Unit Type or Serial Number to be lost. This operation restores the NV to a fresh state. This is done from the ARM HyperTerm console while Trace messages are being displayed.

Hold the Ctrl key, and type the sequence, “NVERAS”. A message should appear indicating that the NV was erased. This will erase any transmit schedule that had been created, and will set all NV values to the appropriate defaults for the configured Unit Type on the next startup.





### 3.8. Setting Transmit Schedule Using Scheduling Utility

It is not necessary to use the Startup Dialog to create a transmit schedule. A scheduling utility is now part of the General Configuration Menu. This can be invoked at any time by pressing the 'C' key, then selecting item 3.

```
COM1 115200 - HyperTerminal
File Edit View Call Transfer Help
*** Transmit Schedule Setup Utility
*** Hit 'V' to View Current Schedule
*** Hit 'C' to Clear All Reservations
*** Hit 'F' to Toggle FATDMA-RATDMA
*** Hit 'A' to Toggle Add/Replace Mode
*** Hit 'T' to Change Tx Mode
*** Hit '+' to Adj Base Slot Upwards
*** Hit '-' to Adj Base Slot Downwards
*** Hit '*' to Toggle Slot Adj Value
*** Hit 'M' to Change Msg ID and Index
*** Hit 'I' to Increase Tx Interval
*** Hit 'D' to Decrease Tx Interval
*** Hit Space to Change Chan Selection
*** Hit ESC to Quit with No Further Schedule Changes
*** Hit Enter to Make Specified Update
*** Adds or Replaces Schedule for Specified MsgID
*** Caution: Not All Setups Make Sense!
*** FATDMA [Rplc] Normal Tx [Slit 0000] Msg 21-0 [ 2 Sec Ivll] Ch A Only
Connected 1:03:04 ANSIW 115200 8-N-1 SCROLL CAPS NUM Capture Print echo
```

**Figure 3-10. Transmit Schedule Setup Utility**

Figure 3-10 shows the control choices for building transmit schedules. The line at the bottom of the screen shows the attributes for a new schedule entry that will be created if the User hits the ENTER key.

Hitting the “V” key displays the current view of the schedule.

Hitting the “C” key clears all reservations.

Hitting the ‘F’ key toggles whether the new schedule item will be FATDMA or RATDMA.

Hitting the ‘A’ key toggles whether the entry will Add or Replace to any entries for the selected Message ID and Index.

Hitting the ‘T’ key toggles the Tx Mode between Normal and Back to Back transmissions. This option is typically set to “Normal”, but special test scenarios might require “Back to Back” transmissions.



communications

---

Aviation Recorders

Marine Systems

Hitting the SHFT and '+' (plus) key increases the value of the "base" or "anchor" slot upwards by 10 for the scheduled transmission.

Hitting the '-' (minus) key decreases the value of the "base" or "anchor" slot downwards by 10 for the scheduled transmission.

Hitting the '\*' key will toggle the slot adjustment to a value between 10 and 1. This allows for fine control over the base slot.

Hitting the 'M' key will cycle through the Message ID and Index as choices for the next field.

Hitting the 'I' key increases the transmit interval value for the scheduled transmission.

Hitting the 'D' key decreases the transmit interval value for the scheduled transmission.

Hitting the Space Bar will cycle through the choices for the final field and change the Channel Selection.

Hitting the ESC button returns the screen to the main "System Configuration Menu."

Hitting the ENTER button displays a message to "Hit Any Key to Continue..." Hit ENTER again, and the Transmit Schedule Setup Utility screen appears.



communications

Aviation Recorders

Marine Systems

## System Configuration Menu

### 4.1. System Configuration Menu

The features of the AtoN “System Configuration Menu” are described in this section. A more detailed explanation of each feature, how it is configured, and its parameters will be provided in a future version of this manual.

To access the “System Configuration Menu” for the ARM, press “C” in the ARM HyperTerminal while it is transmitting data normally. The window appears, as shown below.

If a different window is open, press “ESC,” so a “Hit Any Key to Reboot” message appears. Press any key, so the system reboots. Press “C” to open the System Configuration Menu.

To configure a specific feature, type in the number or letter associated with it in the menu. This opens self-explanatory options at the bottom of the screen.

```
ATON 1 - HyperTerminal
File Edit View Call Transfer Help
002:00:33.850 IecSrv: *** IEC 62320-2 Sentence Mode is [CDV]
002:00:34.039 PrcZDA: IEC Chan 1 [GPS_ID2] UTC <> 00-00-0000

*** L3 AT91 AtoN Project, [Rev 1.15I of 22-May-08]
*** System Time: 002:00:34.129 ***

*** System Configuration Menu ***

1. Show Current Configuration Info
2. Set Unit MMSI
3. Set Configured Lat and Lon
4. Show Current Transmit Schedule
5. Create New Transmit Schedule
6. Set Attributes for Scheduled Binary Msg Types
7. Set System Startup Time (following Standby)
8. Enable or Disable 62320-2 FDIS Mode
9. Enable or Disable Standby Operation
  a. Enable or Disable Acquisition Subsystem Control
  b. Enable or Disable SART Relay Feature
  c. Set SART Relay Mode Parameters
  d. Enable or Disable DGNSS Serial Input
  e. Set Tx Test Mode Parameters

Enter Selection (1 .. e) or ESC to Exit: _
```

**Figure 4-11. System Configuration Menu**

When “1” is entered in the “System Configuration Menu,” the “Current Configuration Information” screen appears with a summary of the AtoN’s existing setup. The “Current Configuration Information” screen is shown below.



communications

Aviation Recorders

Marine Systems

```
ATON 1 - HyperTerminal
File Edit View Call Transfer Help
Enter Selection (1 .. e) or ESC to Exit: 1
*** Software [Rev 1.15I of 22-May-08]
*** AtoN Configuration is [Zeni Lite Type 3D]
*** Serial Number is [000531167]
*** MMSI is [0]
*** Base Station MMSI is [0]
*** AtoN Name is [L3_ATON]
*** Configured Lat is [91 0.0000 N]
*** Configured Lon is [181 0.0000 E]
*** Base Startup Time is [10] Secs
*** Receiver Operation is [Enabled]
*** RAIDMA Support is [Enabled]
*** Standby Operation is [Enabled]
*** Acquisition Subsystem Ctl is [Enabled]
*** SART Relay Feature is [Disabled]
*** DGNSS Input is [Disabled]
*** IEC 62320-2 Sentence Mode is [CDV]
*** Flash Code/Data Checksum = C1D6
*** SDRAM Code/Data Checksum = C1D6
*** Code/Data Size [217381, 0x00035125] Bytes
*** Hit Any Key to Continue ..._
Connected 0:05:58 ANSI 115200 8-N-1 SCROLL CAPS NUM Capture Print echo
```

**Figure 4-12. Current Configuration Information Screen**

To set the MMSI, enter “2” in the main “System Configuration Menu,” and the option shown below appears at the bottom of the screen.

```
ATON 1 - HyperTerminal
File Edit View Call Transfer Help
*** L3 AT91 AtoN Project. [Rev 1.15I of 22-May-08]
*** System Time: 000:25:45.554 ***
*** System Configuration Menu ***
1. Show Current Configuration Info
2. Set Unit MMSI
3. Set Configured Lat and Lon
4. Show Current Transmit Schedule
5. Create New Transmit Schedule
6. Set Attributes for Scheduled Binary Msg Types
7. Set System Startup Time (following Standby)
8. Enable or Disable 62320-2 FDTS Mode
9. Enable or Disable Standby Operation
a. Enable or Disable Acquisition Subsystem Control
b. Enable or Disable SART Relay Feature
c. Set SART Relay Mode Parameters
d. Enable or Disable DGNSS Serial Input
e. Set Tx Test Mode Parameters
Enter Selection (1 .. e) or ESC to Exit: 2
Enter MMSI [000000000] (or '0' for Default):
Connected 0:56:44 ANSI 115200 8-N-1 SCROLL CAPS NUM Capture Print echo
```

**Figure 4-13. MMSI Mode**



## communications

### Aviation Recorders

### Marine Systems

To set the Latitude and Longitude, enter “3” in the main “System Configuration Menu” and the option appears at the bottom of the screen, as shown below.

```
ATON 1 - Hyper Terminal
File Edit View Call Transfer Help
*** System Time: 000:01:20.915 ***
*** System Configuration Menu ***
 1. Show Current Configuration Info
 2. Set Unit MMSI
 3. Set Configured Lat and Lon
 4. Show Current Transmit Schedule
 5. Create New Transmit Schedule
 6. Set Attributes for Scheduled Binary Msg Types
 7. Set System Startup Time (following Standby)
 8. Enable or Disable 62320-2 FDIS Mode
 9. Enable or Disable Standby Operation
 a. Enable or Disable Acquisition Subsystem Control
 b. Enable or Disable SART Relay Feature
 c. Set SART Relay Mode Parameters
 d. Enable or Disable DGNSS Serial Input
 e. Set Tx Test Mode Parameters

Enter Selection (1 .. e) or ESC to Exit: 3
Enter Configured Lat (Deg, Min, N/S) [91 0.0000 N]:
Enter Configured Lon (Deg, Min, E/W) [181 0.0000 E]: _

Connected 0:01:28 ANSI 115200 8-N-1 SCROLL CAPS NUM Capture Print echo
```

**Figure 4-14. Configure Latitude and Longitude**

To view the current transmit schedule, enter “4” in the main “System Configuration Menu,” and the screen shown below summarizes the information at the bottom.

```
ATON 1 - Hyper Terminal
File Edit View Call Transfer Help
 1. Show Current Configuration Info
 2. Set Unit MMSI
 3. Set Configured Lat and Lon
 4. Show Current Transmit Schedule
 5. Create New Transmit Schedule
 6. Set Attributes for Scheduled Binary Msg Types
 7. Set System Startup Time (following Standby)
 8. Enable or Disable 62320-2 FDIS Mode
 9. Enable or Disable Standby Operation
 a. Enable or Disable Acquisition Subsystem Control
 b. Enable or Disable SART Relay Feature
 c. Set SART Relay Mode Parameters
 d. Enable or Disable DGNSS Serial Input
 e. Set Tx Test Mode Parameters

Enter Selection (1 .. e) or ESC to Exit: 4

*** AtoN Transmit Schedule>
  ChA FATDMA MMSI 000000000 [Msg 21-00 0000 Secs] 00:00 Slt 0000 Ivl 000075
*** Hit Any Key to Continue ..!_

Connected 0:04:30 ANSI 115200 8-N-1 SCROLL CAPS NUM Capture Print echo
```

**Figure 4-15. Configure Transmit Schedule**



communications

Aviation Recorders

Marine Systems

To set the transmit data, enter “5” in the main “System Configuration Menu,” and a screen opens with the features and descriptions shown below.

```
ATON 1 - HyperTerminal
File Edit View Call Transfer Help
*** Transmit Schedule Setup Utility
*** Hit 'V' to View Current Schedule
*** Hit 'C' to Clear All Reservations
*** Hit 'F' to Toggle FATDMA-RATDMA
*** Hit 'A' to Toggle Add/Replace Mode
*** Hit 'T' to Change Tx Mode
*** Hit '+' to Adj Base Slot Upwards
*** Hit '-' to Adj Base Slot Downwards
*** Hit '*' to Toggle Slot Adj Value
*** Hit 'M' to Change Msg ID and Index
*** Hit 'I' to Increase Tx Interval
*** Hit 'D' to Decrease Tx Interval
*** Hit Space to Change Chan Selection
*** Hit ESC to Quit with No Further Schedule Changes
*** Hit Enter to Make Specified Update
*** Adds or Replaces Schedule for Specified MsgID
*** Caution: Not All Setups Make Sense!
*** FATDMA [Rplc] Normal Tx [Sl1 0000] Msg 21-0 [ 2 Sec Iv1] Ch A Only
Connected 1:03:59 ANSI 115200 8-N-1 SCROLL CAPS NUM Capture Print echo
```

Figure 4-16. Transmit Schedule Setup Utility

To set attributes for schedule binary messages, enter “6” in the main “System Configuration Menu,” and the option appears at the bottom of the screen.

```
ATON 1 - HyperTerminal
File Edit View Call Transfer Help
*** FATDMA [Rplc] Normal Tx [Sl1 0000] Msg 21-0 [10 Sec Iv1] Alt Ch A/B
*** L3 AT91 Aton Project, [Rev 1.15I of 22-May-08]
*** System Time: 000:05:01.421 ***
*** System Configuration Menu ***
1. Show Current Configuration Info
2. Set Unit MMSI
3. Set Configured Lat and Lon
4. Show Current Transmit Schedule
5. Create New Transmit Schedule
6. Set Attributes for Scheduled Binary Msg Types
7. Set System Startup Time (following Standby)
8. Enable or Disable 62320-2 FDIS Mode
9. Enable or Disable Standby Operation
a. Enable or Disable Acquisition Subsystem Control
b. Enable or Disable SART Relay Feature
c. Set SART Relay Mode Parameters
d. Enable or Disable DGNSS Serial Input
e. Set Tx Test Mode Parameters
Enter Selection (1 .. e) or ESC to Exit: 6
*** No Binary Msgs Scheduled, Hit Any Key to Continue ...
Connected 1:07:58 ANSI 115200 8-N-1 SCROLL CAPS NUM Capture Print echo
```

Figure 4-17. Set Attributes for Scheduled Binary Message Types



## communications

### Aviation Recorders

#### Marine Systems

To set the system startup time, enter “7” in the main “System Configuration Menu,” and the screen shown below displays options to increase or decrease the time.

```
ATON 1 - HyperTerminal
File Edit View Call Transfer Help
3. Set Configured Lat and Lon
4. Show Current Transmit Schedule
5. Create New Transmit Schedule
6. Set Attributes for Scheduled Binary Msg Types
7. Set System Startup Time (following Standby)
8. Enable or Disable 62320-2 FDIS Mode
9. Enable or Disable Standby Operation
  a. Enable or Disable Acquisition Subsystem Control
  b. Enable or Disable SART Relay Feature
  c. Set SART Relay Mode Parameters
  d. Enable or Disable DGNSS Serial Input
  e. Set Tx Test Mode Parameters

Enter Selection (1 .. e) or ESC to Exit: 7

*** Set Startup Seconds (After Standby)

*** Hit 'I' to Increase Startup Time
*** Hit 'D' to Decrease Startup Time

*** Hit ESC to Quit with No Change
*** Hit Enter to Make Specified Update

*** Startup Seconds [ 101 ] _

Connected 1:16:57  ANSI  115200 8-N-1  SCROLL  CAPS  NUM  Capture  Print echo
```

**Figure 4-18. Setting System Startup Time**

To set the 62320-2 FDIS Mode, enter “8” in the main “System Configuration Menu”. The features appear in the screen, as shown below.

```
ATON 1 - HyperTerminal
File Edit View Call Transfer Help
1. Show Current Configuration Info
2. Set Unit MMSI
3. Set Configured Lat and Lon
4. Show Current Transmit Schedule
5. Create New Transmit Schedule
6. Set Attributes for Scheduled Binary Msg Types
7. Set System Startup Time (following Standby)
8. Enable or Disable 62320-2 FDIS Mode
9. Enable or Disable Standby Operation
  a. Enable or Disable Acquisition Subsystem Control
  b. Enable or Disable SART Relay Feature
  c. Set SART Relay Mode Parameters
  d. Enable or Disable DGNSS Serial Input
  e. Set Tx Test Mode Parameters

Enter Selection (1 .. e) or ESC to Exit: 8

*** Set 62320-2 Sentence Mode

*** Hit Space Bar to Change Mode
*** Hit ESC to Quit with No Changes

*** Hit ENTER to Retain 62320-2 CDV  Mode:

Connected 1:19:25  ANSI  115200 8-N-1  SCROLL  CAPS  NUM  Capture  Print echo
```

**Figure 4-19. Setting 62320-2 FDIS Mode**



## communications

### Aviation Recorders

#### Marine Systems

To change the standby mode, enter “9” in the main “System Configuration Menu,” and the screen shown below displays the option.

```
ATON 1 - HyperTerminal
File Edit View Call Transfer Help
1. Show Current Configuration Info
2. Set Unit MMSI
3. Set Configured Lat and Lon
4. Show Current Transmit Schedule
5. Create New Transmit Schedule
6. Set Attributes for Scheduled Binary Msg Types
7. Set System Startup Time (following Standby)
8. Enable or Disable 62320-2 FDIS Mode
9. Enable or Disable Standby Operation
  a. Enable or Disable Acquisition Subsystem Control
  b. Enable or Disable SART Relay Feature
  c. Set SART Relay Mode Parameters
  d. Enable or Disable DGNSS Serial Input
  e. Set Tx Test Mode Parameters

Enter Selection (1 .. e) or ESC to Exit: 9

*** Enable or Disable Standby Operation

*** Hit Space Bar to Toggle On/Off
*** Hit ESC to Quit with No Changes

*** Hit ENTER to Retain Enabled Setting: _
```

**Figure 4-20. Controlling Standby Operation**

To control the acquisition subsystem, enter “a” in the main “System Configuration Menu,” and the screen shown below displays the option.

```
ATON 1 - HyperTerminal
File Edit View Call Transfer Help
1. Show Current Configuration Info
2. Set Unit MMSI
3. Set Configured Lat and Lon
4. Show Current Transmit Schedule
5. Create New Transmit Schedule
6. Set Attributes for Scheduled Binary Msg Types
7. Set System Startup Time (following Standby)
8. Enable or Disable 62320-2 FDIS Mode
9. Enable or Disable Standby Operation
  a. Enable or Disable Acquisition Subsystem Control
  b. Enable or Disable SART Relay Feature
  c. Set SART Relay Mode Parameters
  d. Enable or Disable DGNSS Serial Input
  e. Set Tx Test Mode Parameters

Enter Selection (1 .. e) or ESC to Exit: a

*** Enable or Disable Acquisition Subsystem Control

*** Hit Space Bar to Toggle On/Off
*** Hit ESC to Quit with No Changes

*** Hit ENTER to Retain Enabled Setting:
```

**Figure 4-21. Controlling Acquisition Subsystem**





## communications

### Aviation Recorders

#### Marine Systems

To enable or disable the SART relay feature, enter “b” in the main “System Configuration Menu,” and the screen shown below displays the option.

```
ATON 1 - HyperTerminal
File Edit View Call Transfer Help
[Icons]
1. Show Current Configuration Info
2. Set Unit MMSI
3. Set Configured Lat and Lon
4. Show Current Transmit Schedule
5. Create New Transmit Schedule
6. Set Attributes for Scheduled Binary Msg Types
7. Set System Startup Time (following Standby)
8. Enable or Disable 62320-2 FDIS Mode
9. Enable or Disable Standby Operation
a. Enable or Disable Acquisition Subsystem Control
b. Enable or Disable SART Relay Feature
c. Set SART Relay Mode Parameters
d. Enable or Disable DGNSS Serial Input
e. Set Tx Test Mode Parameters

Enter Selection (1 .. e) or ESC to Exit: b

*** Enable or Disable SART Relay Feature

*** Hit Space Bar to Toggle On/Off
*** Hit ESC to Quit with No Changes

*** Hit ENTER to Retain Disabled Setting: _
```

**Figure 4-22. Controlling the SART Relay Mode**

To set the SART relay parameters, enter “c” in the main “System Configuration Menu,” and the screen shown below displays options for the parameters.

```
ATON 1 - HyperTerminal
File Edit View Call Transfer Help
[Icons]
6. Set Attributes for Scheduled Binary Msg Types
7. Set System Startup Time (following Standby)
8. Enable or Disable 62320-2 FDIS Mode
9. Enable or Disable Standby Operation
a. Enable or Disable Acquisition Subsystem Control
b. Enable or Disable SART Relay Feature
c. Set SART Relay Mode Parameters
d. Enable or Disable DGNSS Serial Input
e. Set Tx Test Mode Parameters

Enter Selection (1 .. e) or ESC to Exit: c

*** SART Relay Mode Parameter Setup

*** Hit 'I' to Increase Interval Minutes
*** Hit 'D' to Decrease Interval Minutes

*** Hit '+' to Increase Duration Minutes
*** Hit '-' to Decrease Duration Minutes

*** Hit ESC to Quit with No Further Changes
*** Hit Enter to Make Specified Update

*** 3 Mins Between Each Tx, Continue 10 Mins from Last Rx

Connected 0:05:03 ANSI 115200 8-N-1 SCROLL CAPS NUM Capture Print echo
```

**Figure 4-23. SART Relay Mode Parameters**

To enable or disable the DGNSS input, enter “d” in the main “System Configuration Menu,” and the screen shown below displays the option.

```

ATON 1 - HyperTerminal
File Edit View Call Transfer Help
1. Show Current Configuration Info
2. Set Unit MMSI
3. Set Configured Lat and Lon
4. Show Current Transmit Schedule
5. Create New Transmit Schedule
6. Set Attributes for Scheduled Binary Msg Types
7. Set System Startup Time (following Standby)
8. Enable or Disable 62320-2 FDIS Mode
9. Enable or Disable Standby Operation
  a. Enable or Disable Acquisition Subsystem Control
  b. Enable or Disable SART Relay Feature
  c. Set SART Relay Mode Parameters
  d. Enable or Disable DGNSS Serial Input
  e. Set Tx Test Mode Parameters

Enter Selection (1 .. e) or ESC to Exit: d

*** Enable or Disable DGNSS Input

*** Hit Space Bar to Toggle On/Off
*** Hit ESC to Quit with No Changes

*** Hit ENTER to Retain Disabled Setting:

```

**Figure 4-24. DGNSS Serial Input**

To set the Tx test mode parameters, enter “e” in the main “System Configuration Menu,” and the screen shown below displays options for configuration.

```

ATON 1 - HyperTerminal
File Edit View Call Transfer Help
8. Enable or Disable 62320-2 FDIS Mode
9. Enable or Disable Standby Operation
  a. Enable or Disable Acquisition Subsystem Control
  b. Enable or Disable SART Relay Feature
  c. Set SART Relay Mode Parameters
  d. Enable or Disable DGNSS Serial Input
  e. Set Tx Test Mode Parameters

Enter Selection (1 .. e) or ESC to Exit: e

*** Tx Test Mode Setup

*** Hit 'I' to Increase VDL Load Percent
*** Hit 'D' to Decrease VDL Load Percent

*** Hit '+' to Increase Target Count
*** Hit '-' to Decrease Target Count

*** Hit Space to Change Chan Selection

*** Hit ESC to Quit with No Further Changes
*** Hit Enter to Make Specified Update

*** Tx Chan A, 100% VDL Load, 50 Tgts

```

**Figure 4-25. Tx Test Mode Parameters**



communications

Aviation Recorders

Marine Systems

## Additional Features

### A.1. Composition of an AIS AtoN Station

The following shows the composition of an AIS AtoN Station.

AtoN station name:   L-3 AtoN  

#### Type of AIS AtoN Station

Type 1                       Type 2                       Type 3

#### Configuration method

Standard PI sentences                       Proprietary terminal interface  
 AIS Standard VDL messages                       AES encryption of VDL message  
 Control receiver

#### Positioning device

Internal EPFS and surveyed position                       Surveyed position only  
 Differential mode with received message 17

#### Transmission

Single channel transmission                       Tx message 21 for synthetic/ virtual AtoN

Transmit power:   12.5   W

#### Access mode msg 21

FATDMA                       RATDMA (type 3 only)

#### Access mode other messages

FATDMA                       RATDMA (type 3 only)                       CSTDMA (type 3 only)

#### Synchronisation:

Indirect UTC (type 3 only)                       Semaphore station (type 3 only)

#### Chaining:

chaining implemented (type 2 and 3 only)



## A.2. Type 1 AIS AtoN Station Alternatives

In addition to Message 21, the controller will compose optional output messages to the VDL, using FATDMA as described in Table 1.

**Table 1. Summary of optional Type 1 AIS AtoN Station messages**

Msg ID	Message name	Message description	Application examples
6	Binary addressed message	Binary data for addressed communication	Monitoring of AtoN lantern, power supply, etc.
8	Binary broadcast message	Binary data for broadcast communication	Meteorological and hydrological data
12	Addressed safety related message	Safety related data for broadcast communication	Warn AtoN malfunctioning
14	Broadcast safety related message	Safety related data for broadcast communication	Warn AtoN malfunctioning

## A.3. Type 3 AIS AtoN Station - alternatives

The Type 3 AIS AtoN Station alternatives include all the Type 1 and Type 2 AIS AtoN Station alternatives.

### A.3.1. Additional controller capability

In addition to Message 21, the controller composes optional output messages to the VDL, as described in Table 2.

**Table 2. Summary of optional Type 3 AIS AtoN Station messages**

Msg ID	Message name	Message description	Application examples
6	Binary addressed message	Binary data for addressed communication	Monitoring of AtoN equipment
8	Binary broadcast message	Binary data for broadcast communication	Meteorological and hydrological data
12	Addressed safety related message	Safety related data for broadcast communication	Warn AtoN malfunctioning
14	Broadcast safety related message	Safety related data for broadcast communication	Warn AtoN malfunctioning



communications

Aviation Recorders

Marine Systems

## **Return Material Policy**

Components and spare parts purchased from L-3 that are discrepant for any of the following reasons may be returned immediately provided the extended value of the parts is in excess of \$100.00.

### **1. Overshipments**

Quantity of parts received in excess of quantity specified on purchase order.

### **2. Wrong Part Numbers**

Receipt of parts numbered other than those identified on a customer order where L-3 has not advised the customer by purchase order acknowledgment, by telex, or by notification on the shipping document that the received part is a replacement for the ordered part.

### **3. Parts Nonconforming to Specifications**

If the extended value of the items is less than \$100.00, the items are to be scrapped instead of returned. When this occurs, notification must be sent to L-3 advising: (1) the reason for the rejection; (2) the items are less than \$100.00 in extended value and have been scrapped, and; (3) whether credit or replacement is desired.

If you wish to return material to L-3 for reasons other than warranty returns or those specified above, please contact an L-3 Account Administrator for authorization before proceeding. A Return Authorization Number will be assigned at this time. Your request should specify the relevant Return Authorization Number, purchase order number, part number, quantity and the reason you wish the part returned.

To assist us in processing these items more efficiently, we ask that all returned goods be accompanied by paperwork that clearly indicates the following:

1. Reason for return.
2. Purchase Order Numbers.
3. Correspondence Reference Number.
4. Return Authorization Number.

### **4. Copies of returned goods paperwork should be mailed to:**

L-3 COMMUNICATIONS CORPORATION  
AVIATION RECORDERS DIVISION  
P. O. Box 3041  
Sarasota, FL 34230-3041  
Attn: Tom Meloche / Marine Systems Product Support Department

### **5. Parts returned under the above conditions should be addressed to:**

L-3 COMMUNICATIONS CORPORATION  
AVIATION RECORDERS DIVISION  
6000 E. Fruitville Road  
Sarasota, FL 34232  
Attn: SERVICE DEPARTMENT

Component and spare parts purchased from L-3 that have been on the customer's shelf for more than 10 weeks from date of receipt; have been installed in a component or on a vessel, are not covered by this procedure. Such parts may be covered by warranty in which case they should be returned through normal warranty channels.



communications

Aviation Recorders

Marine Systems

### **RETURN OF MATERIAL UNDER WARRANTY**

**1. Material should be returned to the following address:**

L-3 COMMUNICATIONS CORPORATION  
AVIATION RECORDERS DIVISION  
6000 E. Fruitville Road  
Sarasota, FL 34232  
Attn: WARRANTY RETURNS

**2. For returning overseas shipments, the following customs broker must be used:**

L-3 COMMUNICATIONS CORPORATION  
AVIATION RECORDERS DIVISION  
c/o A.J. Arango  
Air Cargo Bldg.  
4700 N. Hoover Blvd.  
Tampa Int'l Airport  
Tampa, Florida 33634  
Tel: (813) 248-9220  
Fax: (813) 248-6013

To ensure prompt handling of material returned under warranty, your return order and shipment should clearly identify the item as a warranty return, and a copy of such return order should accompany the shipment. Status of warranty in process will be provided by the Warranty Administrator.

**3. Warranty claims and warranty return orders pertaining to components and spare parts returned should be mailed to the following address:**

L-3 COMMUNICATIONS CORPORATION  
AVIATION RECORDERS DIVISION  
P. O. Box 3041  
Sarasota, FL 34230-3041

Attn: Marine Systems Warranty Administrator  
Tel: (941) 377-5574  
Fax: (941) 377-5591

### **RETURNED GOODS**

Goods returned to stock for credit, at the request of the Buyer, and authorized by the Seller, will be subject to a restocking charge of 10% of the purchase price if notified within 30 days of the order, and 25% of the purchase price if notified after 30 days of the order.

### **CANCELLATION CHARGE**

Any order wishing to be canceled must be approved by the pertinent Account Administrator and may be accountable for a cancellation fee of 15%. This cancellation fee shall take into account expenses already incurred and commitments made by L-3.



communications

Aviation Recorders

Marine Systems

## **AtoN IEC Sentences**

### **C.1. Introduction**

An AtoN transmits 1371 Message 21 (the AtoN Position Report) according to some configured schedule. The function of such a device would be to provide a warning (Aid to Navigation) to approaching vessels. The AtoN transmission schedule and VDL slot assignments would be determined by a competent authority and used to configure the AtoN prior to installation and activation.

### **C.2. Working Group 14 Sentence Usage**

The IEC Working Group 14 committee has created a document containing the PI (Presentation Interface) sentences for AtoN IEC 62320-2 compliance. The L-3 AtoN software has been developed based on the interface defined by this document. This section will describe the primary sentences and how they are used to configure an AtoN and interact with it once it is operational. The sentences to be considered are **AID, ACF, ACE, AAR, and MPR**.

An AtoN as defined by IEC 62320-2 can be configured with multiple MMSI values (unique identifiers) in order to provide Virtual and/or Synthetic AtoN operation. An AtoN can also act as a relay point in a chain of AtoNs to allow for remote configuration of AtoNs using the VDL. Furthermore an AtoN can be configured to use RATDMA for transmissions on the VDL. All of these features are optional AtoN enhancements that are not discussed here. It is the intent of this section to focus on the use of the PI (AtoN serial interface) to configure an AtoN for autonomous FATDMA and/or RATDMA transmission of **Message 21** and, optionally, the transmission of some combination or subset of **Messages 6, 8, 12, and 14**. The assumption is that the PI will be used to configure a schedule of FATDMA and/or RATDMA transmissions of the aforementioned messages, and that the PI will also be used to provide the payloads for any of the optional messages.

The system model on which this discussion is based would have an AtoN configured using the **AID, ACF, ACE and AAR** sentences prior to installation or activation of the AtoN. Of course there is nothing that precludes subsequent reconfiguration of an AtoN using either a direct PI connection or a remote VDL link. However, once the AtoN is operational, the **MPR** sentence would be used to provide payloads for the optional messages.

An important point to be made is that the source of the **AID, ACF, ACE, and AAR** sentences would likely be a host computer system tightly coupled to an AIS Base Station, and under control of a competent authority. Such a system (or the person running it) needs to have knowledge of the VDL allocations in the area of deploy-



communications

Aviation Recorders

Marine Systems

ment and the working set of AtoNs in terms of MMSI assignments, target locations, etc.

### C.3. The AID Sentence

The **AID** sentence provides a means for setting the MMSI for a “real” AtoN. It also allows for establishing additional “virtual” MMSI identities for an AtoN, and for providing the MMSIs of AtoNs in the relay chain used for remote configuration of AtoNs over the VDL. The sentence can also be used for restoring an AtoN to the factory default MMSI by specifying the deletion of the “real” MMSI setting.

It is important to note that when the **AID** sentence is used to set the “real” MMSI for an AtoN, the PI must provide the current MMSI as well. This makes it important that AtoNs be shipped from the factory with a known, fixed MMSI, or that some mechanism be provided for determining the current MMSI setting. The L-3 AtoNs use MMSI 0 as the default setting. It is also worth noting that later versions of the AtoN software support a proprietary IEC sentence that will restore the AtoN to the MMSI 0 state.

Since the **MPR** sentence provides no destination MMSI when used for an addressed binary message (1371 Message 6) the AtoN needs some mechanism for setting the destination MMSI to be used for these transmissions. The **MPR** sentence provides only the payload for a specified binary message type. The **AID** sentence has been extended in the **FDIS** version of IEC 62320-2 to include the ability to specify the destination MMSI. This is referred to as the “other” MMSI and uses a type field of “O”.

### C.4. The ACF and ACE Sentences

The **ACF** and **ACE** sentences are used to establish certain Message 21 content including configured location (Lat and Lon for the AtoN), dimensions, and name for both “real” and “virtual” AtoNs. These sentences are also used to specify VDL channel selections; transmit power levels, “off position threshold” and various exception condition behavior characteristics for a “real” AtoN.

Several fields in the **ACF** sentence do not correspond to configurable attributes of an AtoN. These include the “Type of EPFD”, the “Position Accuracy”, and the “Virtual Flag”. The first two attributes are typically a function of the AtoN hardware design and the method used for obtaining position information. For example, the L-3 AtoN uses an internal uBlox GPS module for position information. The AtoN software recognizes the **GGA** sentences that come from this device, and the associated GP Talker ID characters that prefix these sentences. This causes the AtoN software to set the EPFD type to the GPS selection, and this provides the value for the corresponding Message 21 field. Likewise the Position Accuracy setting is a function of the position source and would not be set using an **ACF** sentence.





It might be desirable to configure an AtoN to use a surveyed position regardless of whether there is an internal GPS device providing position information. In this case the **ACF** sentence “Position Accuracy” qualifier. The **ACF** sentence would be providing a sort of override command.

## C.5. The AAR Sentence

The **AAR** sentence is used to configure the transmit schedule for “real” and “virtual” AtoNs. This includes the schedule for Message 21 transmissions and any of the optional data-oriented messages (Message 6, 8, 12, 14, etc.).

The content for a Message 21 transmission is determined primarily based on configured parameters and current operating conditions. However, an AtoN may need to transmit multiple variants of a particular data-oriented message type. For example, the same AtoN may be configured to transmit a Message 6 containing data logger status according to one schedule, and a Message 6 containing flasher status according to a different schedule. The AtoN uses a Message Index value to distinguish between variants associated with a single Message ID. The **AAR** sentence specifies a schedule for a particular MMSI, Message ID, and Message Index. Furthermore a different schedule can be established for transmission on the two AtoN AIS Channels.

## C.6. Use of AAR Sentence for Scheduling RATDMA Transmissions

The **AAR** sentence contains a field that indicates whether the schedule is for an FATDMA or RATDMA transmission. When this field is set to “1” to indicate RATDMA, it is important to note that the IEC 62320-2 document specifies that the Interval field represents seconds rather than slots. Refer to the section later in this appendix for a discussion of **CDV** and **FDIS** issues and the following section that specifically addresses how the **AAR** sentence has been affected.

## C.7. Add or Replace Behavior in AAR Sentence Processing

The **AAR** sentence provides a mechanism for explicitly deleting all existing schedule entries for a particular MMSI, Message ID, Message ID Index and AIS Channel combination.

## C.8. The MPR Sentence

The **MPR** sentence provides the payload for AtoN data-oriented messages. This message is the linkage between AtoN peripheral devices and the AtoN schedule. While the **AAR** sentence provides the schedule for transmission of AIS binary messages such as Message 6, 8, 12, and 14, there still needs to be a means by which the payload for these messages is obtained.



communications

Aviation Recorders

Marine Systems

The L-3 AtoN software allows the MMSI field of the **MPR** sentence to be set to 0. This is taken to mean “MMSI of this AtoN”.

The first 16 bits of the payload segment of a 1371 Message 6 and Message 8 represents a DAC and FI specification. The 10-bit DAC and 6-bit FI must be provided as the first 16 bits of the encapsulated, ASCII-encoded payload. This is represented by the first three payload characters. Since each payload character represents 6 bits of payload data, the 18 bits of the first three characters (6 bits times 3) contain the DAC, FI and two additional bits of payload.

## C.9. The MPR Sentence and the Transmission Schedule

As stated earlier, the **MPR** sentence provides payload information for 1371 Binary Messages 6, 8, 12, and 14. There is an inherent relationship between an **MPR** sentence and the schedule entries created using the **AAR** sentence. That is, an **MPR** sentence for a particular MMSI, Message ID, and Message ID Index combination contains a payload that will be used to build a 1371 Binary message of the corresponding Message ID type. There is a fundamental question, however, as to when that message will be transmitted over the VDL. Assuming that an **AAR** has created a schedule for the specific MMSI, Message ID, and Message ID Index combination, and assuming that the “Use Next” field (also known as the “Broadcast behavior field”) in the **MPR** sentence is set to “0”, then the payload will be stored until the next scheduled transmission for that combination.

If the “Use Next” field is set to “1”, or if there is no schedule for the MMSI, Message ID, and Message ID Index combination contained in the **MPR** sentence, then the corresponding 1371 Binary Message will be built immediately and queued for transmission using either RATDMA or reserved Message 0 FATDMA slots. If the AtoN does not support RATDMA and there are no reserved Message 0 FATDMA slots within four seconds of the arrival of the **MPR**, the message will simply be discarded.

Note that **MPR** payloads are not preserved through Sleep/Standby/Power Down cycles. Therefore a new **MPR** must be provided each time an AtoN wakes up.

## C.10. Extended Format for MPR Sentence

In the extended form of the **MPR** sentence supported by the L-3 AtoN, the “Total Number of Sentences” field is set to 0 to identify the extended format. The “Message ID” and “Message ID Index” fields specify the binary message type for which the extended information applies. The message type must already have been scheduled using an **AAR** sentence or other supported method. The “Sentence Number” field (sometimes erroneously referred to as “Sequence Number”) is used to specify the required preparation time in seconds for that message type. The default value is 15 seconds, and if this is acceptable the extended **MPR** is unnecessary. The upper limit is 1800 seconds (30 minutes). The “Use Next Available Slot” field is normally set to



communications

Aviation Recorders

Marine Systems

“0”, but can be set to “1” to cause the AtoN to retain power to the GPS module when entering standby (low power) mode during the preparation interval for the specified message type. This is a special requirement for certain integrated daughter boards that require GPS power while building certain message types.

### **C.11. Synthetic Position Report VDO Sentences**

In some cases the data acquisition subsystem requires information from the AtoN in order to construct certain binary payloads. Examples would be the current AtoN position, the Off Position flag, etc. Most of the information of interest is contained in the AtoN MSG 21 Position Report. An external device connected to an AtoN through one of the IEC PI channels can obtain this information from the VDO sentences generated by the AtoN whenever a message is transmitted. The L-3 AtoN software has been enhanced such that a synthetic MSG 21 VDO is generated every few seconds, independently of the MSG 21 transmission schedule. These synthetic VDO sentences contain a special Channel ID marker. While real MSG 21 VDO sentences show either “A” or “B” in this field (depending on the actual AIS transmit channel), these synthetic sentences show “X” or “Y”. The sentences contain “X” if UTC has not been established, and “Y” if UTC has been established.

### **C.12. Alternate Off-Position Schedule Using Message 21-2**

The Message ID index is normally meaningless when scheduling Message 21 transmissions with one notable exception. A schedule for Message 21, Message Index 2, represents the Off-Position reporting schedule for Message 21 when the Off-Position behavior is configured as “Mode 1” (Alternate Reporting interval), and the AtoN is in the Off-Position state.

### **C.13. Proprietary IEC Sentences**

As of Rev 1.14J of the AtoN software, support for a proprietary IEC sentence has been added. This sentence returns the current position and UTC date and time as provided by the internal GPS module. The sentence format is as follows:

```
$PL3A,QATON1
```

The response sentence takes the following form:

```
$PL3A,ATON1,000007762,2720.0578,N,08227.0534,W,11,22:29:11,02/08/2008
```

The first field following the “ATON1” string is the AtoN MMSI. This is followed by the Latitude and Longitude in standard IEC format. The “11” field in the above example represents the UTC second associated with the position report. This is followed by UTC time and date.

As of Rev 1.15I of the AtoN software, support for another proprietary IEC sentence has been added. This sentence resets the MMSI to 0 and clears the Reservation



communications

Aviation Recorders

Marine Systems

List. It also echoes the sentence string to the IEC port. The sentence format is as follows:

\$PL3A,ATONR