

PTR5518 --Bluetooth 4.0 Module

Coin-size Ultra Low Power Bluetooth 4.0 Low Energy RF Module

Features

- Complete Bluetooth low energy solution (Bluetooth 4.0), single mode compliant, Integrated Bluetooth low energy stack/profiles.
- 2.4 GHz transceiver
 - -93 dBm sensitivity in Bluetooth® low energy mode, -96 dBm sensitivity@250kbps,
 - TX Power -20 to +4 dBm in 4 dB steps
 - 13 mA peak RX, 10.5 mA peak TX (0 dBm)
 - RSSI (1 dB resolution)
- ARM® Cortex™-M0 32 bit processor, 256 kB flash memory, 16 kB RAM.
 - 275 µA/MHz running from flash memory
 - 150 µA/MHz running from RAM
 - Serial Wire Debug (SWD)
- Ultra low current consumption , Flexible Power Management
 - Supply voltage range 1.8 V to 3.6 V
 - 2.5 µs wake-up using 16 MHz RCOSC
 - 0.4 µA @ 3 V OFF mode
 - 0.5 µA @ 3 V in OFF mode + 1 region RAM retention
 - 2.3 µA @ 3 V ON mode, all blocks IDLE
- Flexible real-time counter and Two 16 bit and one 24 bit timers with counter mode
- AES Coprocessor, Random Number Generator ,Watchdog Timer ,Temperature sensor
- Rich set of Peripheral: ADC, SPI, 2-wire , and UART. Programmable Peripheral Interconnect(PPI)
- Internal RC Oscillator 32.768 kHz(± 250 ppm).
- Configurable I/O mapping (I/O signals can use any pin, Simple layout of external application)
- Ultra small size(smaller than CR2032 coin battery), about 15mmx15mmx2.5mm with Antenna.

Typical Applications:

- - 2.4 GHz Bluetooth low energy systems
- - Proprietary 2.4 GHz systems
- - Sports and leisure equipment
- - Mobile phone accessories
- - Health Care and Medical
- - Consumer Electronics, Game pads
- - Human Interface Devices, Remote control
- - Building environment control / monitoring
- - RFID, Security Applications

Pin Description of Module (Top View) :

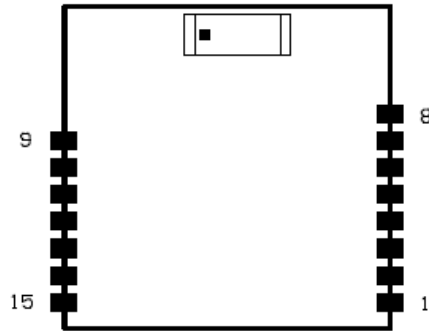

Pin No.	Name	Description	Note
1	P0.08	I/O	
2	P0.09	I/O	
3	P0.12	I/O	
4	SWDIO	Debug and flash programming I/O	
5	SWCLK	Debug and flash programming I/O	
6	P0.17	I/O	
7	P0.18	I/O	
8	P0.19	I/O	
9	GND	Power Ground	
10	VDD	Power Suply (1.9~3.6V)	
11	P0.25	I/O	
12	P0.26	I/O	ADC IN 0
13	P0.27	I/O	ADC IN 1
14	P0.28	I/O	
15	P0.29	I/O	

Block diagram:

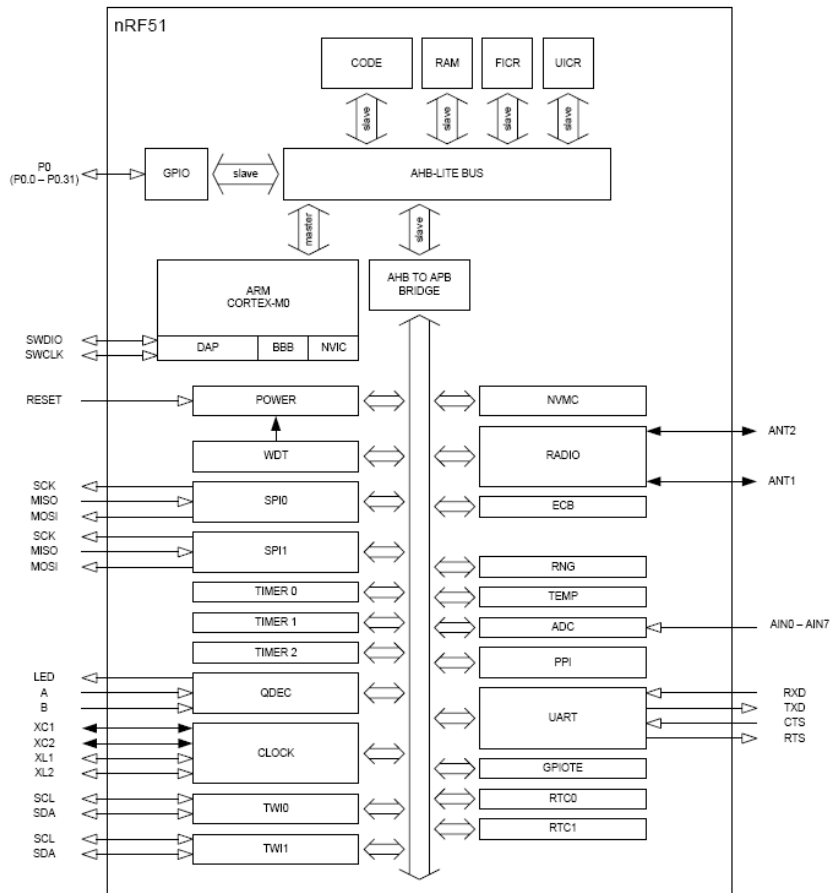

HW debug and flash programming of Module :

Pin	Flash Program interface
SWDIO	Debug and flash programming I/O
SWCLK	Debug and flash programming I/O

This is the hardware debug and flash programming of module, J-Link Lite support, please refer www.segger.com.

Performance Data:

Transmitter specification:

Symbol	Description	Min.	Typ.	Max.	Units	Test level
P_{RF}	Maximum output power		4		dBm	4
P_{RFC}	RF power control range	20	24		dB	2
$PRFCR$	RF power accuracy			± 4	dB	1

Receiver specification:

Symbol	Description	Min.	Typ.	Max.	Units	Test level
Receiver operation						
PRX_{MAX}	Maximum received signal strength at < 0.1% PER		0		dBm	1
$PRX_{SENS,2M}$	Sensitivity (0.1% BER) @ 2 Mbps		-85		dBm	2
$PRX_{SENS,1M}$	Sensitivity (0.1% BER) @ 1 Mbps		-90		dBm	2
$PRX_{SENS,250k}$	Sensitivity (0.1% BER) @ 250 kbps		-96		dBm	2
$P_{SENS IT}$ 1 Mbps BLE	Receiver sensitivity: Ideal transmitter		-93		dBm	2
$P_{SENS DT}$ 1 Mbps BLE	Receiver sensitivity: Dirty transmitter		-91		dBm	2

Radio current consumption:

Symbol	Description	Min.	Typ.	Max.	Units	Test level
$I_{TX,+4dBm}$	TX only run current @ $P_{OUT} = +4$ dBm		16		mA	4
$I_{TX,0dBm}$	TX only run current @ $P_{OUT} = 0$ dBm		10.5		mA	4
$I_{TX,-4dBm}$	TX only run current @ $P_{OUT} = -4$ dBm		8		mA	2
$I_{TX,-8dBm}$	TX only run current @ $P_{OUT} = -8$ dBm		7		mA	2
$I_{TX,-12dBm}$	TX only run current @ $P_{OUT} = -12$ dBm		6.5		mA	2
$I_{TX,-16dBm}$	TX only run current @ $P_{OUT} = -16$ dBm		6		mA	2
$I_{TX,-20dBm}$	TX only run current @ $P_{OUT} = -20$ dBm		5.5		mA	2
$I_{TX,-30dBm}$	TX only run current @ $P_{OUT} = -30$ dBm		5.5		mA	2
$I_{START,TX}$	TX startup current ¹		7		mA	1
I_{RX}	RX only run current @ 1 Mbps		13		mA	4
$I_{START,RX}$	RX startup current ²		8.7		mA	1

1. Average current consumption (at 0 dBm TX output power) for TX startup (130 μ s), and when changing mode from RX to TX (130 μ s).
2. Average current consumption for RX startup (130 μ s), and when changing mode from TX to RX (130 μ s).

CPU current consumption:

Symbol	Description	Min.	Typ.	Max.	Units	Test level
$I_{CPU, Flash}$	Run current @ 16 MHz, Executing code from flash memory		4.4 ¹		mA	2
$I_{CPU, RAM}$	Run current @ 16 MHz, Executing code from RAM		2.4 ²		mA	1
$I_{START, CPU}$	CPU startup current		600		μ A	1
$t_{START, CPU}$	IDLE to CPU execute	0	3		μ s	1

1. Includes CPU, flash, 1V2, 1V7, RC16M
2. Includes CPU, RAM, 1V2, RC16M
3. t_{1V2} if 1V2 regulator is not running already

Power management:

Symbol	Description	Note	Min.	Typ.	Max.	Units	Test level
I_{OFF}	Current in SYSTEM-OFF, no RAM retention			420		nA	1
$I_{OFF, 16k}$	Current in SYSTEM-OFF mode 16 kB SRAM retention			740		nA	1
$I_{OFF, 8k}$	Current in SYSTEM-OFF mode 8 kB SRAM retention			530		nA	1
I_{OFF2ON}	OFF to CPU execute transition current			400		μ A	1
t_{OFF2ON}	OFF to CPU execute			9.6	10.6	μ s	1
I_{ON}	SYSTEM-ON base current			2.3		μ A	2

For more detail information, please refer nRF51822 datasheet.

PCB Layout (TOP VIEW) :

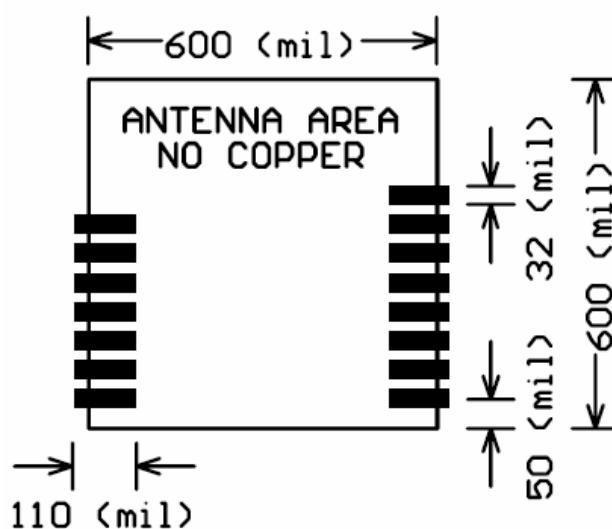

unit: mil

PIN Description

NO	PIN	INPUT\OUTPUT	Description
1	EN	I	Enabled Pins, External Pull up: Falling Edge: Module starts Broadcasting, and connect with device Raising Edge: No matter what status of the module, the module will enter into deep sleep mode. (420 nA)
2	TX	O	UART TX
3	RX	I	UART RX
4	—	—	Not used
5	—	—	Not used
6	CTS	O	Input signal to wake up MCU (Optional) 0: Means module's sending data to MCU , Master's ready to receive data from Module 1: Means no data sending to MCU, or Module data sending Finished
7	RTS	I	Data output request to wake up module 0: Means MCU will send data out, and Module is waiting for the data from MCU 1: Means no data sending to module, or MCU data sending finished
8	FLOW_CTR	O	UART Flow Control: 0: UART can send data to module 1: Module is busy, UART can't send data to Module Note: TO Prevent UART data from losing, suggest to check the pin status before MCU sending data, waiting for a falling edge , then send data out (wait for no longer than a broadcasting or an interval) , see the Chart 3-1 for reference.
9	GND	—	Power Ground

10	VCC	—	Power Supply' Positive (3 ~ 3.6V)
11	CFG_MODE	I	Select Parameter configuration mode, interval pull up 0: Simple mode: Input level to set Baud Rate through BAUD_0、BAUD_ Input level to set Connection Interval through CNITV_0、CNITV_1 1: AT command mode: Sending AT command through UART to set Baud Rate and Connection Interval 。
12	BAUD_0	I	Set Baud Rate (Under Simple Mode) , Internal Pull down: BAUD_0, BAUD_1: 00: 9600
13	BAUD_1	I	01: 19200 10: 38400 11: 115200
14	CNITV_0	I	Set Connection Interval (Under Simple Mode) , Internal Pull down: CNITV_0, CNITV_1: 00: 20ms
15	CNITV_1	I	01: 100ms 10: 500ms 11: 1000ms

Pls note that ;

- 1. This User Manual is a guide for OEM /Integrators , is Limited for OEM/Integrator installations Only.**
- 2. The OEM integrator is responsible for ensuring that the end-user has no manual instruction to remove or install module**
- 3. Separate approval is required for all other operating configurations, including portable configurations with respect to Part 2.1093 and different antenna configurations**
- 4. The authorized antennas per Part 15.204 (including antenna specification).**

Warning:

This device complies with Part 15 of the FCC Rules. Operation is subject to the following two conditions: (1) this device may not cause harmful interference, and (2) this device must accept any interference received, including interference that may cause undesired operation.

changes or modifications not expressly approved by the party responsible for compliance could void the user's authority to operate the equipment.

Please notice that if the FCC identification number is not visible when the module is installed inside another device, then the outside of the device into which the module is installed must also display a label referring to the enclosed module. This exterior label can use wording such as the following: "Contains FCC ID: 2AA72-PTR5518"

Important Notice:

- Reserves the right to make corrections, modifications, and/or improvements to the product and/or its specifications at any time without notice.
- Assumes no liability for the user's product and/or applications.
- Products are not authorized for use in safety-critical applications, including but not limited to life-support applications.

ATTENTION!

Electrostatic Sensitive Device
Observe Precaution for handling.

