



©2008 Lennox Industries Inc.  
Dallas, Texas, USA

# INSTALLATION INSTRUCTIONS

## Dave Lennox *Signature*<sup>®</sup> Collection CBX32MV Units

MULTI-POSITION AIR HANDLER  
505,343M  
05/08  
Supersedes 04/08

**TP** Technical  
Publications  
Litho U.S.A.

### ⚠ WARNING

Improper installation, adjustment, alteration, service or maintenance can cause personal injury, loss of life, or damage to property.

Installation and service must be performed by a licensed professional installer (or equivalent) or a service agency.

### ⚠ CAUTION

Physical contact with metal edges and corners while applying excessive force or rapid motion can result in personal injury. Be aware of, and use caution when working near these areas during installation or while servicing this equipment.

### ⚠ IMPORTANT

The Clean Air Act of 1990 bans the intentional venting of refrigerant (CFCs, HCFCs and HFCs) as of July 1, 1992. Approved methods of recovery, recycling or reclaiming must be followed. Fines and/or incarceration may be levied for noncompliance.

### Table of Contents

CBX32MV Upflow/Downflow Unit Dimensions . . . .	2
CBX32MV Horizontal LH/RH Unit Dimensions . . . .	3
General Information . . . . .	3
Shipping and Packing List . . . . .	3
Requirements . . . . .	3
Installing the Unit . . . . .	4
Brazing Connections . . . . .	8
Installing the Condensate Drain . . . . .	8
Inspecting and Replacing Filters . . . . .	9
Sealing the Unit . . . . .	9
Adjusting the BDC3 Blower Control Board . . . . .	9
Adjusting the Blower Speed . . . . .	10
Making Electrical Connections . . . . .	14
Repairing Cabinet Insulation . . . . .	16

RETAIN THESE INSTRUCTIONS FOR FUTURE REFERENCE

## IMPORTANT INFORMATION TO INSTALLER

CHECK FOR AND REMOVE THE FOLLOWING ITEMS BEFORE OPERATING UNIT.

BLOWER MOTOR SHIPPING BOLT

A

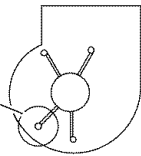

BLOWER HOUSING SUPPORT PAD

B

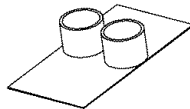

HORIZONTAL DRAIN PAN (SEE UPFLOW APPLICATIONS ON PAGE 4 AND DOWNFLOW APPLICATIONS ON PAGE 6)

E

TOP CAP SHIPPING BRACKET (REPLACE SCREWS IN TOP CAP AFTER REMOVAL)

C



BLOWER MOTOR SHIPPING BRACKET

D

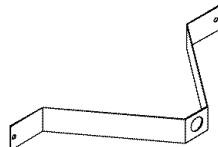

REFRIGERANT LINE CAPS (SEE BRAZING CONNECTION ON PAGE 8)

F

CONFIGURATION JUMPERS (IF NECESSARY) (SEE ADJUSTING THE BDC3 BLOWER CONTROL BOARD ON PAGE 10.)

G

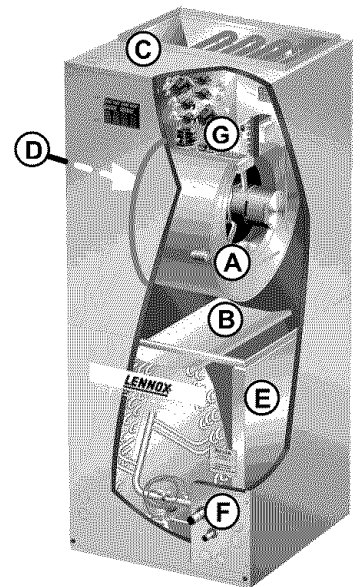

## CBX32MV Upflow and Downflow Unit Dimensions - Inches (Millimeters)

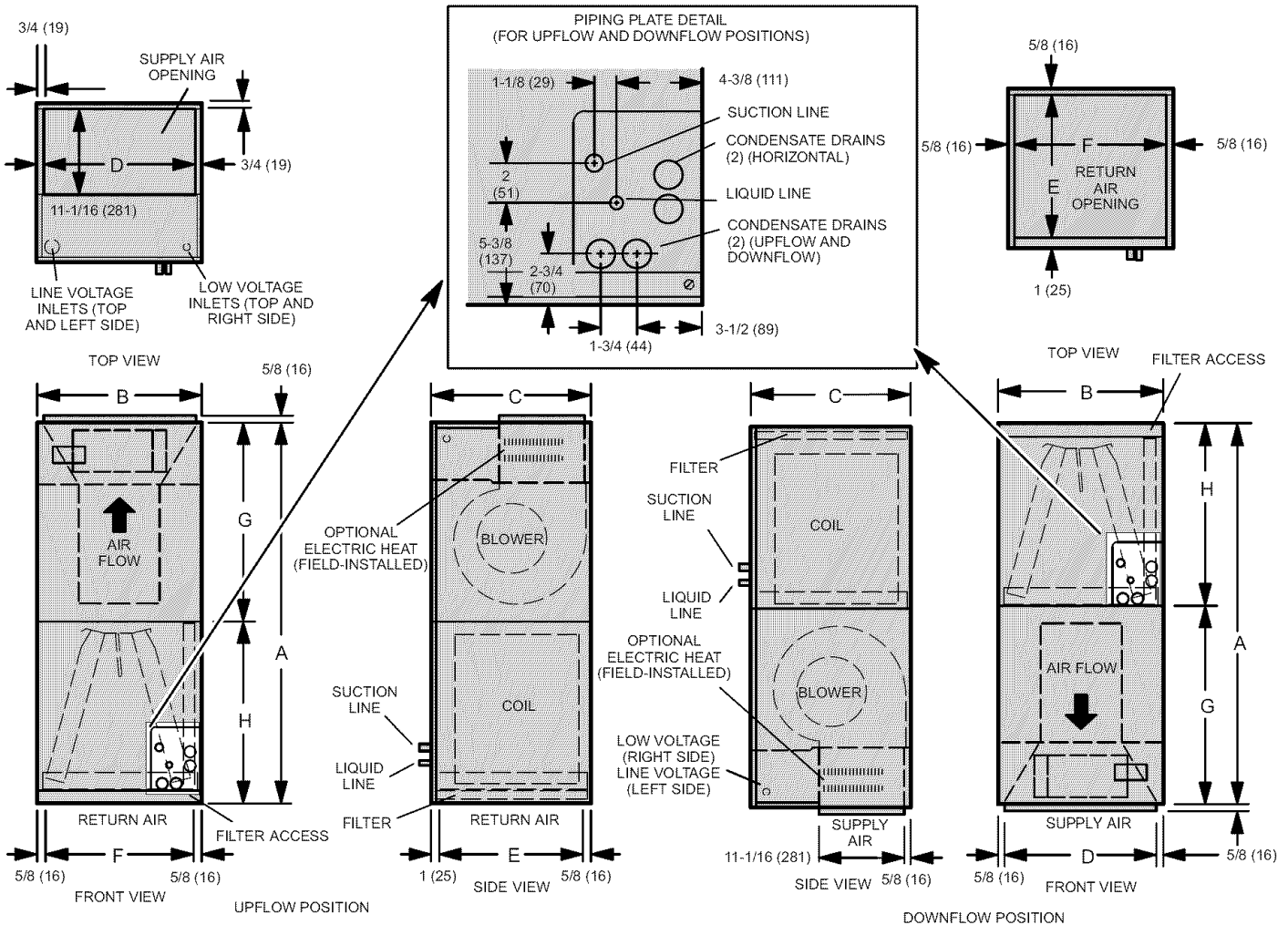

### CBX32MV Model Dimensions (Upflow, Downflow, Left- and Right-Hand Horizontal applications)

Dim.	-018/024	-024/030	-036	-048 and -060	-068
	in. (mm)	in. (mm)	in. (mm)	in. (mm)	in. (mm)
<b>A</b>	45-1/4 (1149)	49-1/4 (1251)	51 (1295)	58-1/2 (1486)	64 (1626)
<b>B</b>	16-1/4 (413)	21-1/4 (540)	21-1/4 (540)	21-1/4 (540)	21-1/4 (540)
<b>C</b>	20-5/8 (524)	20-5/8 (524)	22-5/8 (575)	24-5/8 (625)	26-5/8 (676)
<b>D</b>	14-3/4 (375)	19-3/4 (502)	19-3/4 (502)	19-3/4 (502)	19-3/4 (502)
<b>E</b>	19 (483)	19 (483)	21 (533)	23 (584)	25 (635)
<b>F</b>	15 (381)	20 (508)	20 (508)	20 (508)	20 (508)
<b>G</b>	24-5/8 (625)	24-5/8 (625)	26-3/8 (670)	27-7/8 (708)	31-3/8 (797)
<b>H</b>	20-5/8 (524)	24-5/8 (625)	24-5/8 (625)	30-5/8 (778)	32-5/8 (829)

## CBX32MV Horizontal Left- and Right-Hand Unit Dimensions - Inches (mm)

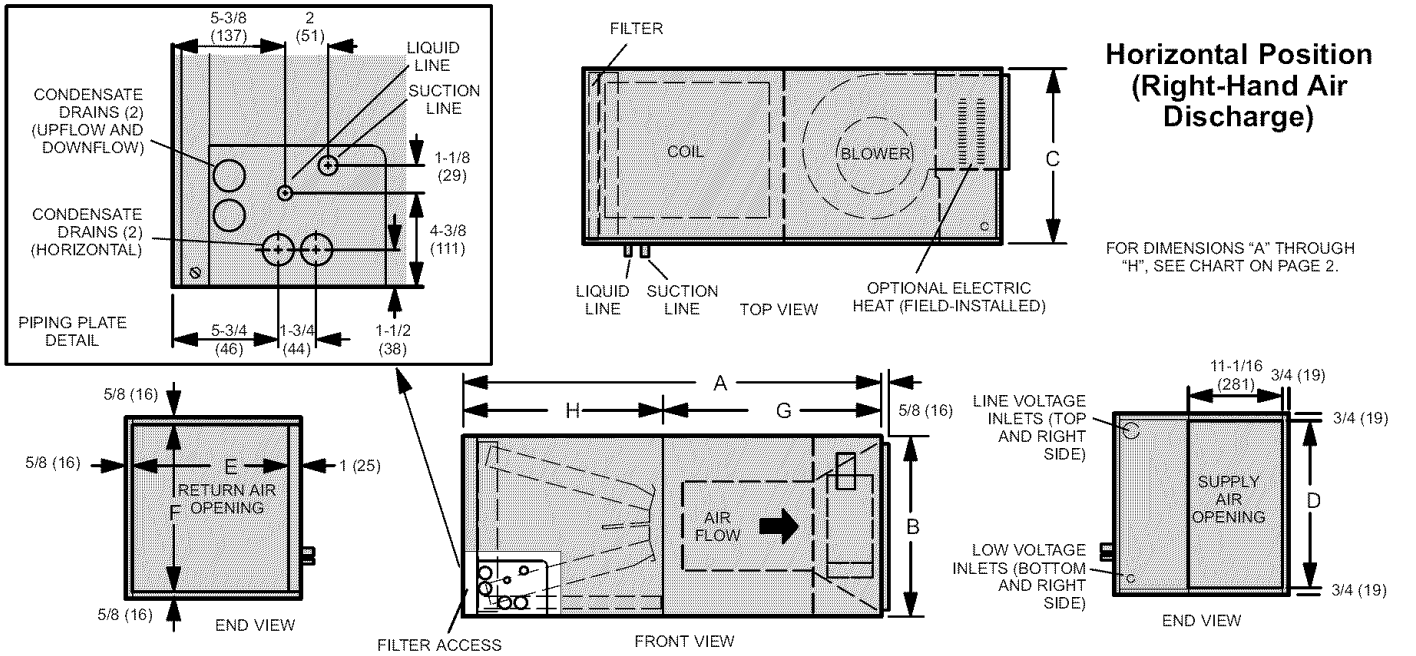

### Horizontal Position (Left-Hand Air Discharge)

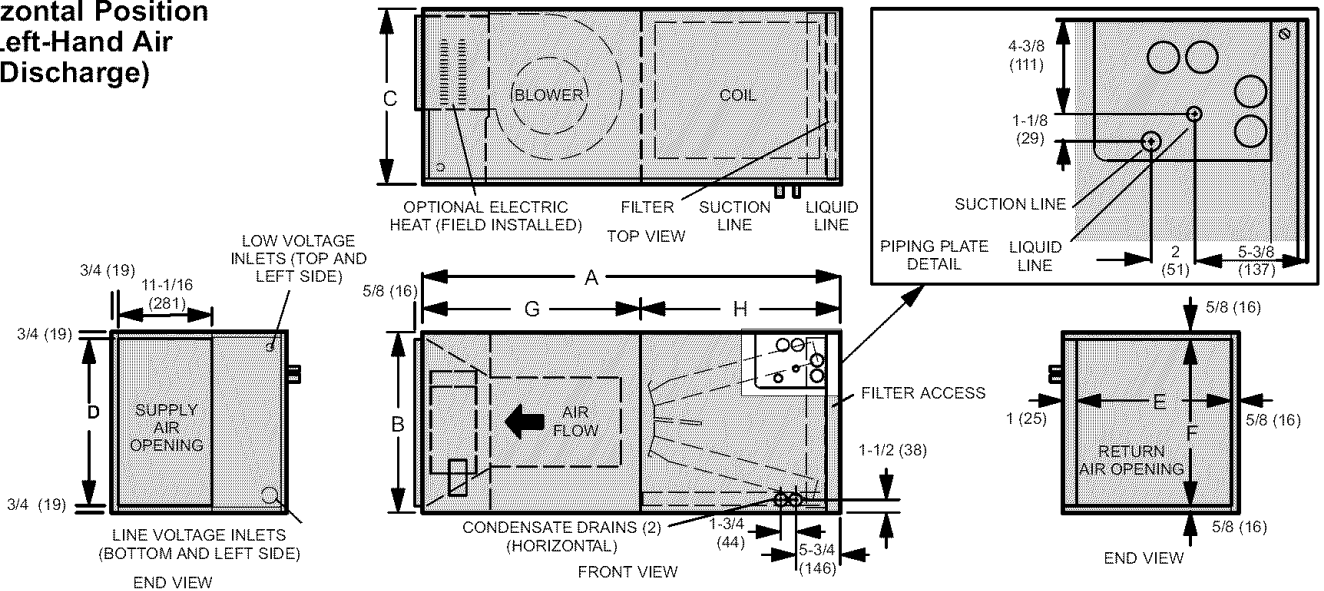

### General Information

The Dave Lennox Signature™ Collection CBX32MV air handler units are designed for installation with optional field-installed electric heat and a matched remote outdoor unit that is charged with HFC-410A refrigerant. These units, designed for indoor installation in multiple positions, are completely assembled for upflow and horizontal right-hand discharge before being shipped from the factory.

These instructions are intended as a general guide and do not supersede local or national codes in any way. Consult authorities having jurisdiction before installation. Check equipment for shipping damage; if found, immediately report damage to the last carrier.

### Shipping and Packing List

Package 1 of 1 contains the following:

- 1 — Assembled air handler unit
- 2 — Downflow shields (if required for downflow configuration only)
- 1 — Drip shield (**for -068 only**)

### Requirements

In addition to conforming to manufacturer's installation instructions and local municipal building codes, installation of Lennox air handler units (with or without optional electric heat), MUST conform with the following National Fire Protection Association (NFPA) standards:

- NFPA No. 90A - Standard for Installation of Air Conditioning and Ventilation Systems

- NFPA No. 90B - Standard for Installation of Residence Type Warm Air Heating and Air Conditioning Systems

This unit is approved for installation clearance to combustible material as stated on the unit rating plate. Accessibility and service clearances must take precedence over combustible material clearances.

**⚠ WARNING**

**Product contains fiberglass wool.**

**Disturbing the insulation in this product during installation, maintenance, or repair will expose you to fiberglass wool. Breathing this may cause lung cancer. (Fiberglass wool is known to the State of California to cause cancer.)**

**Fiberglass wool may also cause respiratory, skin, and eye irritation.**

**To reduce exposure to this substance or for further information, consult material safety data sheets available from address shown below, or contact your supervisor.**

**Lennox Industries Inc.  
P.O. Box 799900  
Dallas, TX 75379-9900**

**Installing the Unit**

**⚠ WARNING**

**Improper installation, adjustment, alteration, service or maintenance can cause property damage, personal injury or loss of life. Installation and service must be performed by a qualified installer or service agency.**

CBX32MV units are factory-configured for upflow and horizontal right-hand discharge installation. For downflow or horizontal left-hand discharge, certain field modifications are required.

**DISASSEMBLE AND REASSEMBLE AIR HANDLER UNIT**

The CBX32MV air handler unit consists of two sections which are shipped assembled from the factory. If necessary, the unit may be disassembled to facilitate setting the unit. Follow the steps below:

**To disassemble:**

1. Remove access panels.
2. Remove both blower and coil assemblies. This will lighten the cabinet for lifting.
3. Remove one screw from the left and right posts inside the unit. Remove one screw from each side on the back of the unit. Unit sections will now separate.

**To reassemble:**

1. Align cabinet sections together.
2. Reinstall screws.
3. Replace blower and coil assemblies.
4. Replace access panel.

**UPFLOW APPLICATION**

Use the following procedures to configure the unit for upflow operations:

*Note - (-068 model Only) Remove access panels and the horizontal drip shield along with the corrugated padding between the blower and coil assembly before operation. Discard drip shields from the foam pads on top of the unit. Shields are used for downflow applications only.*

1. The horizontal drain pan must be removed when the coil blower is installed in the upflow position. Removing horizontal drain pan will allow proper airflow and increase efficiency.
2. After removing horizontal drain pan, place the unit in desired location. Set unit so that it is level. Connect return and supply air plenums as required using sheet metal screws as illustrated in figure 1.
3. Install units that have no return air plenum on a stand that is at least 14" from the floor to allow for proper air return. Lennox offers an optional upflow unit stand as listed in table 1 on page 4.

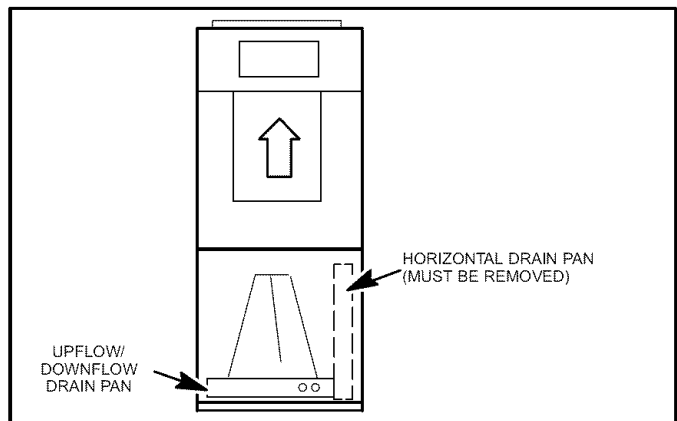

**Figure 1. Upflow Configuration**

**Table 1. Optional Unit Side Stand (Upflow Only)**

Models	Kit Numbers
-018/024	45K31
-024/030, -036, -048, -060 and -068	45K32

**HORIZONTAL RIGHT-HAND DISCHARGE APPLICATION**

Use the following procedures to configure the unit for horizontal right-hand discharge operations:

*NOTE - For horizontal applications, a secondary drain pan is recommended. Refer to local codes.*

*Note - (-068 Model Only) Before operating the unit, remove access panels and the horizontal drip shield and the corrugated padding between the blower and coil assembly. Discard the corrugated padding and the downflow drip shields from the foam pads on top of the unit.*

*Note - (-068 Model Only) Install the horizontal shield on the front edge of the horizontal drain pan as illustrated in figure 2.*

1. No further adjustment is necessary. Set unit so that it is sloped 1/4 inch towards the drain pan end of the unit.

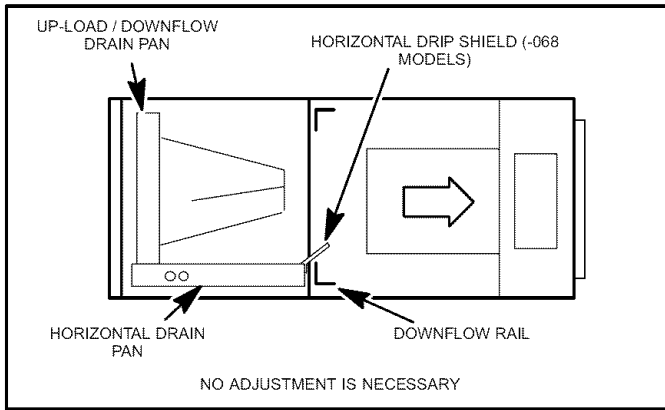

**Figure 2. Right-Hand Discharge Configuration**

- If the unit is suspended, the entire length of the cabinet must be supported. If you use a chain or strap, use a piece of angle iron or sheet metal attached to the unit (either above or below) to support the length of the cabinet. Use securing screws no longer than 1/2 inch to avoid damaging the coil or filter as illustrated in figure 3. Use sheet metal screws to connect the return and supply air plenums as required.

**HORIZONTAL RIGHT-HAND DISCHARGE APPLICATION IN HIGH HUMIDITY AREAS**

For horizontal applications in high humidity areas remove the downflow rail closest to the drain pan.

**To remove rail:**

- Remove the screws from the rail at the back of unit and at the cabinet support rail.
- Remove the downflow rail then replace screws.
- Seal around the exiting drain pipe, liquid line, and suction line to prevent humid air from infiltrating into the unit.

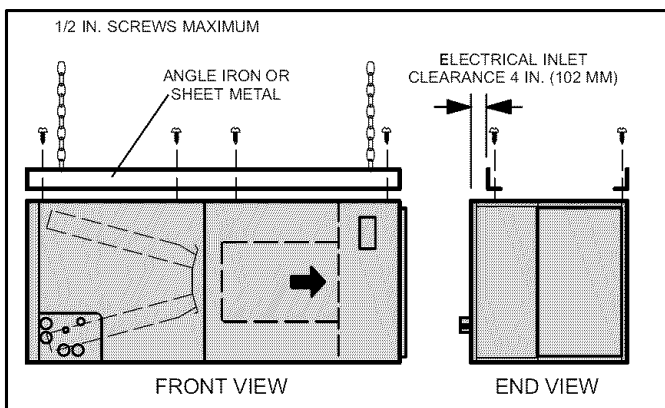

**Figure 3. Suspending Horizontal Unit**

**! IMPORTANT**

When removing the coil, there is possible danger of equipment damage and personal injury. Be careful when removing the coil assembly from a unit installed in right- or left-hand applications. The coil may tip into the drain pan once it is clear of the cabinet. Support the coil when removing it.

**HORIZONTAL LEFT-HAND DISCHARGE APPLICATION**

Use the following procedures to configure the unit for horizontal left-hand discharge operations:

*NOTE - For horizontal applications, a secondary drain pan is recommended. Refer to local codes.*

*Note - (-068 Model Only) Remove access panels and horizontal drip shield from the corrugated padding between the blower and coil assembly. Discard the corrugated padding and the downflow drip shields from the foam pads on top of the unit. (The shields are used for downflow applications only.)*

- Pull the coil assembly from unit. Pull off the horizontal drain pan.
- Remove the drain plugs from back drain holes on horizontal drain pan and reinstall them on front holes.

**! IMPORTANT**

After removal of drain pan plug(s), check drain hole(s) to verify that drain opening is fully open and free of any debris. Also check to make sure that no debris has fallen into the drain pan during installation that may plug up the drain opening.

- Rotate drain pan 180° front-to-back and install it on the opposite side of the coil.
- Remove screws from top cap. Remove horizontal drip shield screw located in the center of the back coil end seal as illustrated in figure 4.
- Rotate horizontal drip shield 180° front to back.
- Remove plastic plug from left hole on coil front end seal and reinstall plug in back hole. Reinstall horizontal drip shield screw in front coil end seal. Drip shield should drain downward into horizontal drain pan inside coil.
- Rotate top cap 180° front-to-back and align with unused screw holes. Holes must align with front and back coil end plates. The top cap has a 45° bend on one side and a 90° bend on the other. The 90° bend must be on the same side as the horizontal drain pan as illustrated in figure 4.

*NOTE - Be very careful when you reinstall the screws into coil end plate engaging holes. Misaligned screws may damage the coil.*

- From the upload position, flip cabinet 90° to the left and set into place. Replace coil assembly. Secure coil in place by bending down the tab on the cabinet support rail as illustrated in figures 4.
- (-068 Model Only)** Install the horizontal shield on the front edge of the horizontal drain pan as shown in figure 5.

*NOTE - For horizontal applications in high humidity areas, remove the downflow rail closest to the drain pan. To remove rail, remove screw from rail at back of unit and at cabinet support rail. Remove downflow rail then replace screws. Also, seal around the exiting drain pipe, liquid and suction lines to prevent infiltration of humid air.*

10. Knock out drain seal plate from access door. Secure plate to cabinet front flange with screw provided.
11. Flip access door and replace it on the unit.
12. Set unit so that it is sloped 1/4 inch toward the drain pan end of the unit. Connect return and supply air plenums as required using sheet metal screws.
13. If suspending the unit, it must be supported along the entire length of the cabinet. If using chain or strap, use a piece of angle iron or sheet metal attached to the unit (either above or below) so that the full length of the cabinet is supported. Use securing screws no longer than 1/2 inch to avoid damage to coil or filter as illustrated in figure 3 on page 5. Connect return and supply air plenums as required using sheet metal screws.

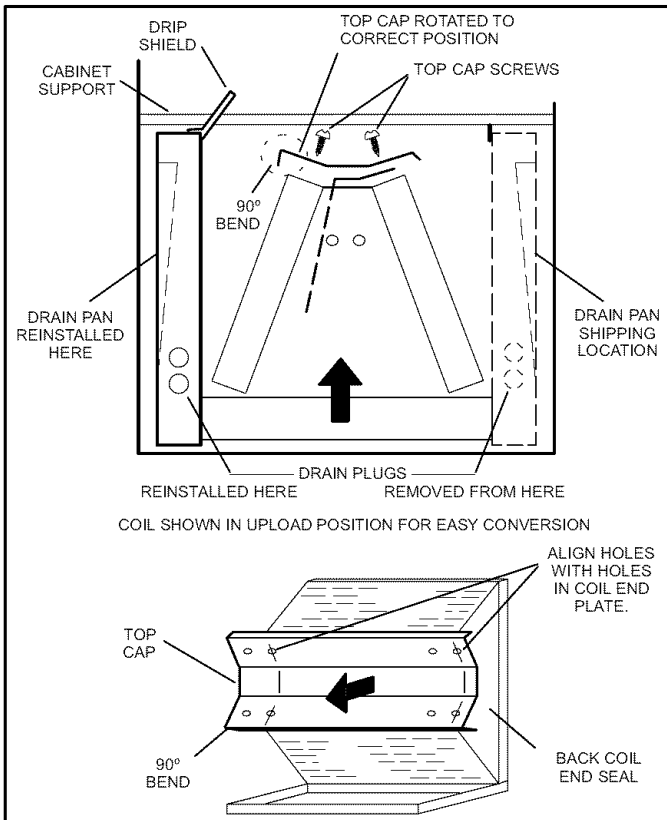

Figure 4. Field Modification for Left-Hand Discharge

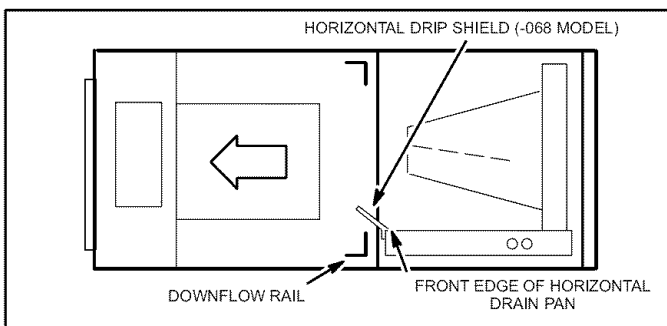

Figure 5. Left-Hand Discharge Configuration

## DOWNFLOW APPLICATION

Use the following procedures to configure the unit for downflow operations:

Table 2 outlines the sizes of the various drip shields.

*Note - (-068 Model Only) Remove the access panels. If necessary, remove the horizontal drip shield and corrugated padding between the blower and coil assembly before operating the unit. Remove the downflow drip shields from the foam pads of top of the unit.*

1. Remove the coil assembly from the unit.
2. For best efficiency and air flow, remove the horizontal drain pan from the units in downflow positions as illustrated in figure 6 on page 6.
3. Rotate cabinet 180° from the upright position. See figure 6. You may need to first remove the blower assembly to lighten the cabinet for lifting.
4. Foam tape that is provided creates a seal between the drip shield and the coil so that water does not leak into the air stream. The foam tape pieces are precut. Apply the tape to the drip shields as illustrated in figure 7 and specified as follows:
  - Apply two pieces of foam tape provided down both ends of each shield. The tape should measure 4-3/4" X 2" (120 X 25 mm). Ensure that the tape covers both sides of the shield equally.
  - Apply the longer piece of 1-inch wide foam tape between the end pieces of tape.
5. From the underside of the coil, install the downflow drip shield firmly in place as illustrated in figure 8.

Table 2. Downflow Drip Shields (Tape Required)

Units	Part Numbers	Length	Width
-018/024	Not Required	Not Required	Not Required
-024/030	LB-74274	15.875	4.6718
-036	LB-74272	17.875	4.6718
-048, -060, and -068	LB-89864	19.875	4.6718

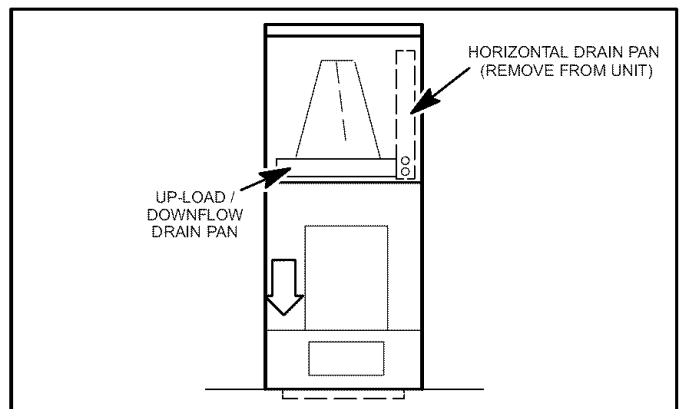
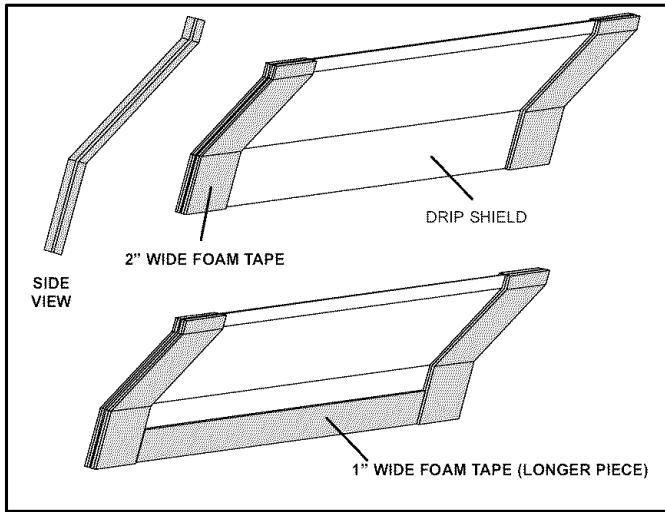
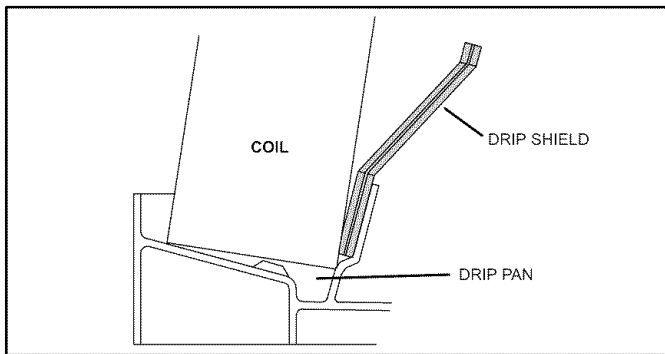

Figure 6. Downflow Discharge Position



**Figure 7. Applying Foam Tape to Drip Shield**



**Figure 8. Downflow Drip Shields**

6. Replace the coil assembly and blower if you have removed it. Replace the coil access panel.
7. Set the unit so that it is level. Using sheet metal screws, connect the return and supply air plenums as required.

**⚠ CAUTION**

If electric heat section with circuit breakers (ECB29/ECB31) is applied to downflow CBX32MV unit, the circuit breakers must be rotated 180° to the UP position. See ECB29/ECB31 installation instructions for more details.

*NOTE - For downflow application, metal or class I supply and return air plenums must be used.*

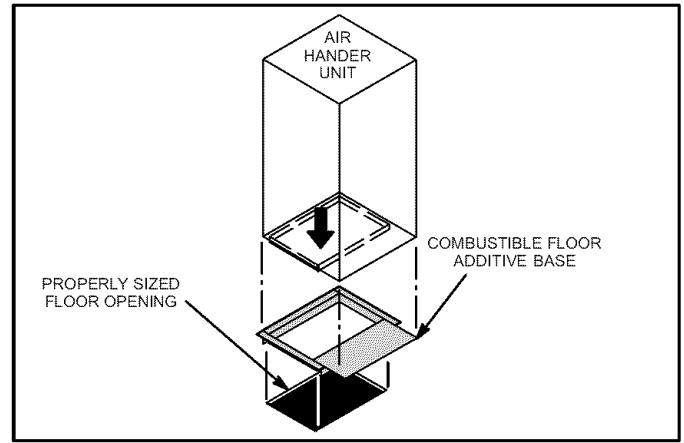

**Figure 9. Combustible Flooring Additive Base**

8. For downflow installation on combustible flooring, an additive base must be used as illustrated in figure 9 on page 7.
9. Cut an opening appropriately sized for combustible base. Base dimensions are illustrated in figure 10. After opening has been cut, set the additive base into opening. Connect outlet air plenum to the additive base. Set the unit on the additive base so flanges of the unit drop into the base opening and seal against the insulation strips. The unit is now locked in place. Install return air plenum and secure with sheet metal screws.

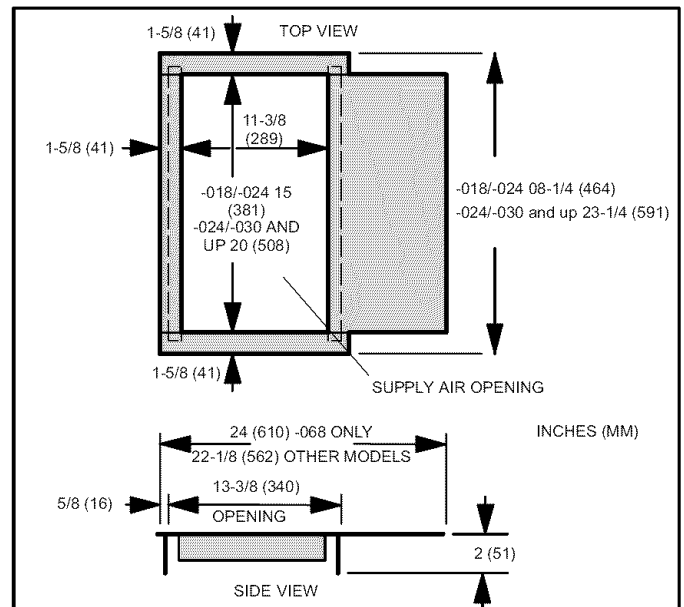

**Figure 10. Downflow Combustible Base Dimensions**

## Brazing Connections

### ⚠ WARNING



#### Danger of explosion!

Can cause equipment damage, injury, or death.

When using a high pressure gas such as dry nitrogen to pressurize a refrigeration or air conditioning system, use a regulator that can control the pressure down to 1 or 2 psig (6.9 to 13.8 kPa).

### ⚠ IMPORTANT

To prevent the build up of high levels of nitrogen when purging, be sure it is done in a well ventilated area. Purge low pressure nitrogen (1 to 2 psig) through the refrigerant piping during brazing. This will help to prevent oxidation and the introduction of moisture into a system.

All CBX32MV air handlers are equipped with a factory-installed, internally mounted check/expansion valve, which is suitable for use in HFC-410A applications. Use Lennox L15 (sweat) series line sets as listed in table 3 on page 8, or use field-fabricated refrigerant lines. L10 (flare) line sets may be used by cutting off flare nut. Refer to the piping section of the Lennox Unit Information Service Manual for proper size, type and application of field-fabricated lines.

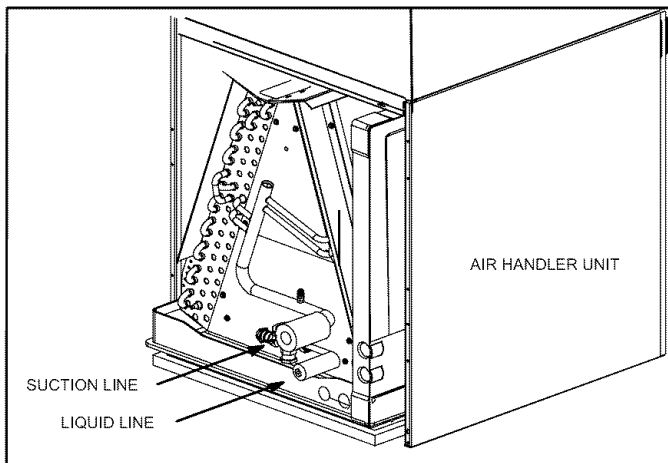

Figure 11. Brazing Connections

**NOTE:** CBX32MV series evaporators use nitrogen or dry air as a holding charge. If there is no pressure when the rubber plugs are removed, check the coil or line set for leaks before installing. After installation, pull a vacuum on the line set and coil before releasing the unit charge into the system.

**NOTE:** Be aware of filter access panel when connecting lines. Filter must be accessible.

**NOTE:** See outdoor unit instructions on how to flow nitrogen through line sets.

1. Remove access panel.
2. Remove the refrigerant line caps from the refrigerant lines.
3. Use a wet rag to protect TXV sensing bulb (or remove it) when brazing suction line connections.
4. Place a wet rag against piping plate and around the suction line connection. The wet rag must be in place to guard against damage to the paint.
5. With the wet rag in place, position field provided elbow fitting to air handler's suction line and line set. Start nitrogen flow before brazing.
6. After the procedure is completed then remove the wet rag.
7. Place wet rag against piping plate and around the liquid line connection. Position liquid line elbow to air handler's suction line and to line set. Start nitrogen flow and begin brazing both connections and after procedure is completed then remove both wet rags.
8. Refer to instructions provided with outdoor unit for leak testing, evacuating and charging procedures.
9. Install access panel.

Table 3. CBX32MV Refrigerant Line Sets

Models	Liquid Line	Vapor/Suction Line	L10 Line Sets	L15 Line Sets
-018/024	3/8 (10)	5/8 (16)	L10-26 20 - 50 ft. (6 - 15m)	L15-26 20 - 50 ft. (6 - 15m)
-024/030 and -036	3/8 (10)	3/4 (19)	L10-41 20 - 50 ft. (6 - 15m)	L15-41 20 - 50 ft. (6 - 15m)
-048	3/8 (10)	7/8 (22)	L10-65 30 - 50 ft. (9 - 15m)	L15-65 30 - 50 ft. (9 - 15m)
-060 and -068	3/8 (10)	1-1/8 (29)	Field Fabricated	Field Fabricated

## Installing the Condensate Drain

Before connecting drain line(s), check drain hole(s) to verify that drain opening is fully open and free of any debris. Also check to make sure that no debris has fallen into the drain pan during installation that may plug up the drain opening.



Connect main condensate drain and route downward to an open drain or sump. Do not connect drain to a closed waste system. See figure 12 for typical condensate trap configuration.

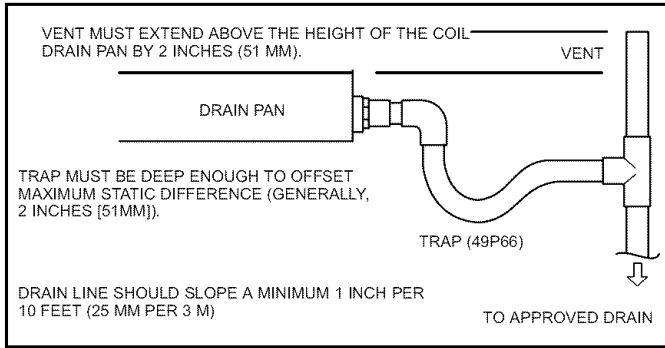

**Figure 12. Typical Condensate Drain**

It is recommended that the auxiliary drain be connected to a drain line for all units. If auxiliary drain is not connected, it must be plugged with provided cap. For downflow units, the auxiliary drain **MUST** be connected and routed to a drain. See figure 13 for auxiliary and main drain locations.

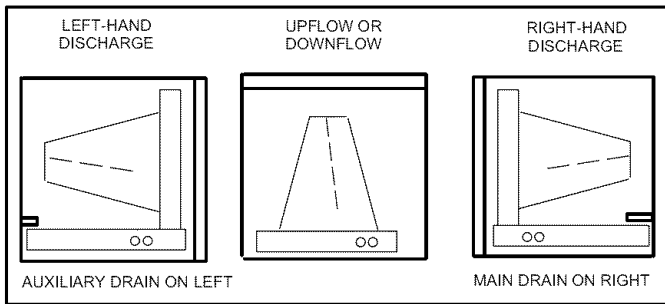

**Figure 13. Auxiliary and Main Drain Locations**

The following practices are recommended to ensure condensate removal:

- Drain piping should not be smaller than the drain connections at drain pan.
- A trap must be installed in the main drain line.
- The trap must be deep enough to offset the difference in static pressure between drain pan and atmosphere. Generally, two inches is satisfactory for medium static applications.
- Horizontal runs must be sloped 1-inch per 10 feet of drain line to offset friction.
- An open vent in the drain line, as illustrated in figure 12, should be used to overcome line length, friction and static pressure.
- Drains should be constructed in a manner to facilitate future cleaning and not interfere with filter access as illustrated in figure 12 on page 9.
- Auxiliary drain should run to an area where homeowner will notice it draining. The auxiliary drain line does not require venting or a trap. Refer to local codes.

## Inspecting and Replacing Filters

### ⚠ IMPORTANT

**Filter access panel must be in place during unit operation. Excessive warm air entering the unit may result in water blow-off problems.**

Filters may be duct-mounted or installed in the cabinet. A filter is installed at the factory. Note that filter access door fits over access panel. Air will leak if the access panel is placed over the filter door.

Filters should be inspected monthly and must be cleaned or replaced when dirty to assure proper furnace operation. Units are equipped with standard throw-away type filters which should be replaced when dirty.

#### To replace filter:

1. Loosen the thumbscrews holding the filter panel in place.
2. Slide the filter out of the guides on either side of cabinet.
3. Insert new filter.
4. Replace panel.

See table 4 for replacement filter sizes.

**Table 4. Filter Dimensions**

Unit Model No.	Filter Size Inches (mm)
-018/024	15 X 20 (381 X 508)
-024/030	20 x 20 (508 x 508)
-036	20 x 22 (508 x 559)
-048 and -060	20 x 24 (508 x 610)
-068	20 x 25 (508 x 635)

## Sealing the Unit

Seal the unit so that warm air is not allowed into the cabinet. Warm air introduces moisture, which results in water blow-off problems. This is especially important when the unit is installed in an unconditioned area.

Make sure the liquid line and suction line entry points are sealed with either the provided flexible elastomeric thermal insulation, or field provided material (e.g. *Armaflex*, *Permagum* or equivalent). Any of the previously mentioned materials may be used to seal around the main and auxiliary drains, and around open areas of electrical inlets.

## Adjusting the BDC3 Blower Control Board

CBX32MV units are equipped with a variable speed motor that is capable of maintaining a specified CFM throughout the external static range. A particular CFM can be obtained by positioning jumpers (**COOL**, **HEAT**, and **ADJUST**) on the BDC3 control board.

The jumpers are labeled 1, 2, 3, and 4. This indicates the selected air volume (CFM). The **ADJUST** jumper is labeled Test, -, +, and Norm. The - and + pin settings are used to add or subtract a percentage of the CFM selected. The Test jumper is used to operate the motor in the test mode. The delay jumper controls the timing pattern in which the fan delay occurs.

Figure 14 illustrates the BDC3 control board. Use either table 8 on page 11, or table 9 on page 12 to determine the correct air volume for heat and cool speed taps.

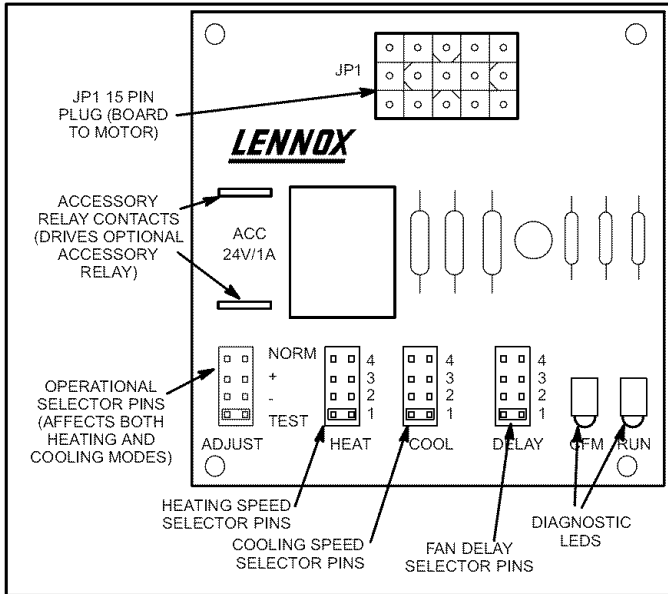

**Figure 14. BDC3 Variable Speed Control Board Selections**

Diagnostic LEDs located on the BDC3 control board are provided to aid in identifying the unit's mode of operation. Certain scenarios will arise depending on the jumper positions. Read through the jumper settings sections before adjusting blower speed. Refer to figure 14 on page 10 for identification.

### Adjusting the Blower Speed

#### Diagnostic LEDs

1. **RUN LED** indicates there is a demand for the blower motor to run.
2. **CFM LED** indicates the cubic feet per minute at which the unit is operating. The light flashes once for approximately every 100 CFM. For example, if the unit is operating at 1000 CFM, **CFM LED** will flash 10 times. If the CFM is 1150, **CFM LED** will flash 11 full times plus one fast or half flash.

At times, the light may appear to flicker or glow. This is normal and occurs when the control is communicating with the motor between cycles.

The appropriate speed, according to application and CFM need, is selected by moving jumper pins.

#### JUMPER SETTINGS

**⚠ IMPORTANT**

**Before changing jumper setting, make sure the motor has completely stopped. Any jumper setting change will not take place while the motor is running.**

Table 5 lists the recommended factory blower speed tap selections for CBX32MV series units. These settings are for nominal tonnage match-ups with the CBX32MV. When matched with other sizes, it is recommended that the CFM be adjusted to approximately 400 CFM per ton.

**Table 5. Recommended Blower Speed Taps**

CBX32MV Air Handler	Speed Tap Selection			
	Cooling		Heating*	
	Note 1.	Note 2.	Note 3.	Note 4.
-018/024, -024/030 and -036	COOL PIN #3	COOL PIN #3	HEAT PIN #4	HEAT PIN #4
-048	COOL PIN #2	COOL PIN #2	HEAT PIN #1	HEAT PIN #1
-060	COOL PIN #3	COOL PIN #3	HEAT PIN #1	HEAT PIN #1
-068	COOL PIN #3	COOL PIN #3	HEAT PIN #4	HEAT PIN #4

**NOTES -**

1. Condensing Unit
2. Heat Pump
3. Condensing Unit with electric heat only
4. Heat Pump with electric heat

\* Minimum setting for heat

To change jumper positions, gently pull the jumper off the pins and insert it onto the desired set of pins. The following section outlines the different jumper selections available and conditions associated with each one as illustrated in figure 14 on page 10.

After the CFM for each application has been determined, the jumper settings must be adjusted to reflect those given in either table 8 on page 11, or table 9 on page 12. From the tables, determine which row of CFM volumes most closely matches the desired CFM. Once a specific row has been chosen (+, NORMAL, or -), CFM volumes from other rows cannot be used. Below are descriptions of the jumper selections.

#### ADJUST JUMPER

The **ADJUST** pins allow the motor to run at normal speed, approximately 10% higher, or approximately 10% lower than normal speed. Table 8 on page 11 lists three rows (+, NORMAL, and -) with their respective CFM volumes. Notice that the normal adjustment setting for heat speed position #3 is 1315 CFM. The + adjustment setting for that position is 1445 CFM and for the - adjustment setting is 1185 CFM. After the adjustment setting has been determined, choose the remaining speed jumper settings from those offered in the table in that row.

The **TEST** pin is available to bypass the BDC3 control and run the motor at approximately 70% to test that the motor is operational. This is beneficial primarily in troubleshooting. G must be energized for motor to run.

#### COOL JUMPER

The **COOL** jumper is used to determine the CFM during either cooling or heat pump operation without a call for electric heat. These jumper selections are activated for cooling when Y2 and DS terminals in the CBX32MV are energized and for heating when Y2 is energized.

Applications **without** the Lennox SignatureStat™ thermostat will provide 70% of the **COOL** CFM during first-stage cooling for two-stage outdoor units. 100% of **COOL** speed is provided for systems with a single-stage outdoor units.

Applications **with** the Lennox SignatureStat thermostat but no demand for de-humidification will operate as follows: during a first-stage cooling call (two-stage outdoor unit), the air volume is 70% of the **COOL** jumper selection. For a normal **COOL** (Pin #2 setting for CBX32MV-036), the CFM is 1125; the reduced speed is 788 CFM (1125 x 70% = 788). This arrangement provides for additional dehumidification during standard first-stage cooling. See tables 11 and 12 for various scenarios concerning use of the SignatureStat thermostat and the CBX32MV series unit.

For applications with Harmony II® zone control, the air handler CFM volume is determined by the Harmony II control center. The minimum Blower speed is predetermined at 300 CFM for -024/030 units, 650 CFM for -036 series units, and 850 CFM for -048, -060 and -068 series units. This speed is not adjustable. See footnotes in tables 8 and 9 on page 12.

With the thermostat set for *Continuous Fan* and without a call for heating or cooling, the CBX32MV will provided 50% of the **COOL** CFM selected.

*NOTE - For two-stage heat pumps, air handler will operate at 70% of the COOL selection until supplemental electric heat is demanded. At that time, the air handler will operate at the HEAT speed selected. This arrangement provides for warmer supply air during second-stage heating.*

**Table 6. CBX32MV-018/024 Air Handler Performance (0 through 0.80 in. w.g. [0 — 200 Pa] External Static Pressure Range)**

ADJUST Jumper Setting	BDC3 Jumper Speed Position															
	HEAT Speed								COOL Speed*							
	1		2		3		4		1		2		3		4	
	cfm	L/s	cfm	L/s	cfm	L/s	cfm	L/s	cfm	L/s	cfm	L/s	cfm	L/s	cfm	L/s
+	715	337	855	403	1000	472	1130	533	465	219	690	325	900	424	1050	495
NORM	670	316	770	363	900	424	1035	488	425	200	620	292	825	389	950	448
—	580	273	700	330	800	377	930	438	385	181	560	264	735	346	850	401

\*First-stage (two-stage units only) cooling is approximately 70% of the COOL speed rating.  
 Continuous fan speed is approximately 50% of COOL speed rating.  
 Lennox Harmony II® Zone Control Applications - Minimum air handler speed is approximately 300 cfm (145 L/s).  
 NOTE - The effect of static pressure, filter and electric heater resistance is included in the air volumes listed.

**Table 7. CBX32MV-024/030 Air Handler Performance (0 through 0.80 in. w.g. [0 — 200 Pa] External Static Pressure Range)**

ADJUST Jumper Setting	BDC3 Jumper Speed Positions															
	HEAT Speed								COOL Speed*							
	1		2		3		4		1		2		3		4	
	cfm	L/s	cfm	L/s	cfm	L/s	cfm	L/s	cfm	L/s	cfm	L/s	cfm	L/s	cfm	L/s
+	800	380	935	440	1070	505	1210	570	660	310	880	415	1100	520	1320	625
NORM	725	340	850	400	975	460	1100	520	600	285	800	380	1000	470	1200	565
—	655	310	765	360	880	415	990	470	540	255	720	340	900	425	1080	510

\*First-stage (two-stage units only) cooling is approximately 70% of the COOL speed rating.  
 Continuous fan speed is approximately 50% of COOL speed rating.  
 Lennox Harmony II® Zone Control Applications - Minimum air handler speed is approximately 300 cfm (145 L/s).  
 NOTE - The effect of static pressure, filter and electric heater resistance is included in the air volumes listed.

**Table 8. CBX32MV-036 Air Handler Performance (0 through 0.80 in. w.g. [0 — 200 Pa] External Static Pressure Range)**

ADJUST Jumper Setting	BDC3 Jumper Speed Positions															
	HEAT Speed								COOL Speed*							
	1		2		3		4		1		2		3		4	
	cfm	L/s	cfm	L/s	cfm	L/s	cfm	L/s	cfm	L/s	cfm	L/s	cfm	L/s	cfm	L/s
+	1230	580	1335	630	1445	680	1545	730	1090	515	1225	580	1380	650	1545	730
NORM	1120	530	1215	575	1315	620	1400	660	975	460	1125	530	1275	600	1400	660
—	1010	475	1200	565	1185	560	1265	595	900	425	1000	470	1135	535	1265	595

\*First-stage (two-stage units only) cooling is approximately 70% of the COOL speed rating.  
 Continuous fan speed is approximately 50% of COOL speed rating.  
 Lennox Harmony II® Zone Control Applications - Minimum air handler speed is approximately 380 cfm (145 L/s).  
 NOTE - The effect of static pressure, filter and electric heater resistance is included in the air volumes listed.

**Table 9. CBX32MV-048 and -060 Air Handler Performance (0 through 0.80 in. w.g. [0 — 200 Pa] External Static Pressure Range)**

ADJUST Jumper Setting	BDC3 Jumper Speed Positions															
	HEAT Speed								COOL Speed*							
	1		2		3		4		1		2		3		4	
	cfm	L/s	cfm	L/s	cfm	L/s	cfm	L/s	cfm	L/s	cfm	L/s	cfm	L/s	cfm	L/s
+	1850	875	1960	925	2090	985	2150	1015	1625	765	1820	860	2055	970	2145	1010
NORM	1705	805	1800	850	1900	895	2005	945	1425	670	1625	765	1805	850	2005	945
—	1560	735	1625	765	1720	810	1770	835	1205	570	1375	650	1555	735	1725	815

\*First-stage (two-stage units only) cooling is approximately 70% of the COOL speed rating.  
 Continuous fan speed is approximately 50% of COOL speed rating.  
 Lennox Harmony II® Zone Control Applications - Minimum air handler speed is approximately 400 cfm (190 L/s).  
 NOTE - The effect of static pressure, filter and electric heater resistance is included in the air volumes listed.

**Table 10. CBX32MV-068 Air Handler Performance (0 through 0.80 in. w.g. [0 — 200 Pa] External Static Pressure Range)**

ADJUST Jumper Setting	BDC3 Jumper Speed Positions															
	HEAT Speed								COOL Speed*							
	1		2		3		4		1		2		3		4	
	cfm	L/s	cfm	L/s	cfm	L/s	cfm	L/s	cfm	L/s	cfm	L/s	cfm	L/s	cfm	L/s
+	1875	885	1975	930	2090	985	2150	1015	1640	775	1840	870	2075	980	2150	1010
NORM	1760	830	1825	860	1920	905	2030	955	1465	690	1625	765	1800	850	2000	945
—	1550	730	1650	775	1725	815	1800	850	1250	590	1390	655	1560	735	1720	810

\*First-stage (two-stage units only) cooling is approximately 70% of the COOL speed rating.  
 Continuous fan speed is approximately 50% of COOL speed rating.  
 Lennox Harmony II® Zone Control Applications - Minimum air handler speed is approximately 500 cfm (235 L/s).  
 NOTE - The effect of static pressure, filter and electric heater resistance is included in the air volumes listed.

**Table 11. Typical CBX32MV Single-Stage Outdoor Unit Operating Sequence**

Operating Sequence		System Demand								System Response			Comments
System Condition	Step	Thermostat Demand						Relative Humidity		Com-pressor	Air Handler CFM (COOL)		
		Y1	Y2	O	G	W1	W2	Status	D				
<b>NO CALL FOR DEHUMIDIFICATION</b>													
Normal Operation	1	On		On	On			Acceptable	24 VAC	High	100%	Compressor and indoor air handler follow thermostat demand	
<b>BASIC MODE (only active on a Y1 thermostat demand)</b>													
Normal Operation	1	On		On	On			Acceptable	24 VAC	High	100%	SignatureStat™ energizes Y1 and de-energizes D on a call for dehumidification	
Dehumidification Call	2	On		On	On			Demand	0 VAC	High	60%/65% 70%*		
<b>PRECISION MODE (operates independent of a Y1 thermostat demand)</b>													
Normal Operation	1	On		On	On			Acceptable	24 VAC	High	100%	Dehumidification mode begins when humidity is greater than set point	
Dehumidification call	2	On		On	On			Demand	0 VAC	High	60%/65% 70%*		
Dehumidification call ONLY	1	On		On	On			Demand	0 VAC	High	60%/65% 70%*	SignatureStat will try to maintain room humidity setpoint by allowing the room space to maintain a cooler room thermostat setpoint**	
Jumpers at indoor unit with a single stage outdoor unit With Condensing unit - Y1 to Y2 and R to O With Heat Pump - Y1 to Y2													

\* During dehumidification, cooling air handler speed is as follows: 70% of COOL cfm for 018/024, 024/030, 65% for 036, 60% for 048 and 060 units.  
 \*\* In precision mode, SignatureStat™ thermostats built BEFORE October 2003 will maintain the room temperature up to 3°F (1.8°C) cooler than room thermostat setting. Thermostats built AFTER October 2003 will maintain the room temperature up to 2°F (1.2°C) cooler than the room thermostat setting in precision mode.

**Table 12. CBX32MV SignatureStat™ Thermostat and Two-Stage Outdoor Unit Operating Sequence**

Operating Sequence		System Demand								System Response		
System Condition	Step	Thermostat Demand						Relative Humidity		Com-pressor	Air Handler CFM (COOL)	Comments
		Y1	Y2	O	G	W1	W2	Status	D			
<b>NO CALL FOR DEHUMIDIFICATION</b>												
Normal Operation - Y1	1	On		On	On			Acceptable	24 VAC	Low	70%	Compressor and indoor air handler follow thermostat demand
Normal Operation - Y2	2	On	On	On	On			Acceptable	24 VAC	High	100%	
<b>Room Thermostat Calls for First-Stage Cooling</b>												
<b>BASIC MODE (only active on a Y1 thermostat demand)</b>												
Normal Operation	1	On		On	On			Acceptable	24 VAC	Low	70%	SignatureStat energizes Y2 and de-energizes D on a call for dehumidification
Dehumidification Call	2	On	On	On	On			Demand	24 VAC	High	60%/65% 70%*	
<b>PRECISION MODE (operates independent of a Y1 thermostat demand)</b>												
Normal Operation	1	On		On	On			Acceptable	24 VAC	Low	70%	Dehumidification mode begins when humidity is greater than set point
Dehumidification call	2	On	On	On	On			Demand	0 VAC	High	60%/65% 70%*	
Dehumidification call ONLY	1	On	On	On	On			Demand	0 VAC	High	60%/65% 70%*	
<b>Room Thermostat Calls for First- and Second-Stage Cooling</b>												
<b>BASIC MODE (only active on a Y1 thermostat demand)</b>												
Normal Operation	1	On	On	On	On			Acceptable	24 VAC	High	100%	SignatureStat energizes Y2 and de-energizes D on a call for dehumidification
Dehumidification Call	2	On	On	On	On			Demand	0 VAC	High	60%/65% 70%*	
<b>PRECISION MODE (operates independent of a Y1 thermostat demand)</b>												
Normal Operation	1	On	On	On	On			Acceptable	24 VAC	High	100%	Dehumidification mode begins when humidity is greater than set point
Dehumidification call	2	On	On	On	On			Demand	0 VAC	High	60%/65% 70%*	
Dehumidification call ONLY	1	On	On	On	On			Demand	0 VAC	High	60%/65% 70%*	
	Jumpers at indoor unit with a two-stage outdoor unit With Condensing unit - Y2 and R to O With Heat Pump - none											SignatureStat will try to maintain room humidity setpoint by allowing the room space to maintain a cooler room thermostat setpoint**
<small>* During dehumidification, cooling air handler speed is as follows: 70% of COOL cfm for 018/024, 024/030, 65% for 036, 60% for 048 and 060 units. ** In precision mode, SignatureStat™ thermostats built BEFORE October 2003 will maintain the room temperature up to 3°F (1.8°C) cooler than room thermostat setting. Thermostats built AFTER October 2003 will maintain the room temperature up to 2°F (1.2°C) cooler than the room thermostat setting in precision mode.</small>												

**HEAT JUMPER**

The **HEAT** jumper is used to determine CFM during electric heat operation only. These jumper selections are activated only when W1 is energized.

**DELAY JUMPER**

The **DELAY** jumper is used to set the specific motor fan operation during cooling mode. Depending on the application, one of four options may be chosen by moving the jumper to the appropriate set of pins.

**#1 Pins Jumped —**

**A** Motor runs at 100% until demand is satisfied.

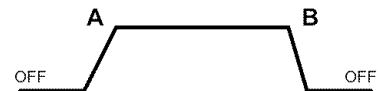

**B** Once demand is met, motor ramps down to stop.

**#2 Pins Jumped —**

**A** Motor runs at 100% until demand is satisfied.

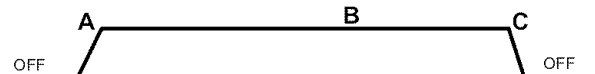

- B Once demand is met, motor runs at 100% for 45 seconds. Then,
- C ramps down to stop.

*NOTE - Air Handler OFF DELAY also applies during heat pump operation*

**#3 Pins Jumpered —**

- A Motor runs at 82% for approximately 7-1/2 minutes. If demand has not been satisfied after 7-1/2 minutes,
- B motor runs at 100% until demand is satisfied.

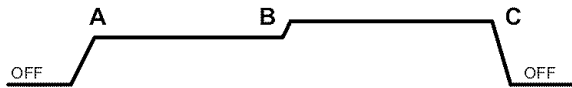

- C Once demand is met, motor ramps down to stop.

**#4 Pins Jumpered —**

- A Motor runs at 50% for 30 seconds.
- B Motor then runs at 82% for approximately 7-1/2 minutes. If demand has not been satisfied after 7-1/2 minutes.
- C Motor runs at 100% until demand is satisfied.
- D Once demand is met, motor runs at 50% for 30 seconds. Then,

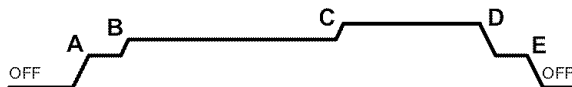

- E ramps down to stop.

**Making Electrical Connections**

**CAUTION**  
USE COPPER CONDUCTORS ONLY.

**WARNING**  
Run 24V Class II wiring only through specified low voltage opening. Run line voltage wiring only through specified high voltage opening. Do not combine voltage in one opening.

Wiring must conform to the current National Electric Code ANSI/NFPA No. 70, or Canadian Electric Code Part I, CSA Standard C22.1, and local building codes. Refer to following wiring diagrams. See unit nameplate for minimum circuit ampacity and maximum over-current protection size.

Select the proper supply circuit conductors in accordance with tables 310-16 and 310-17 in the National Electric Code, ANSI/NFPA No. 70 or tables 1 through 4 in the Canadian Electric Code, Part I, CSA Standard C22.1.

This unit is provided with holes for conduit. Use provided caps to seal holes not used. Refer to figure 16 for unit schematic wiring diagram. Refer to figures 15 through 17 on page 16 for typical field wiring.

Separate openings have been provided for 24V low voltage and line voltage. Refer to the dimension illustration of specific location.

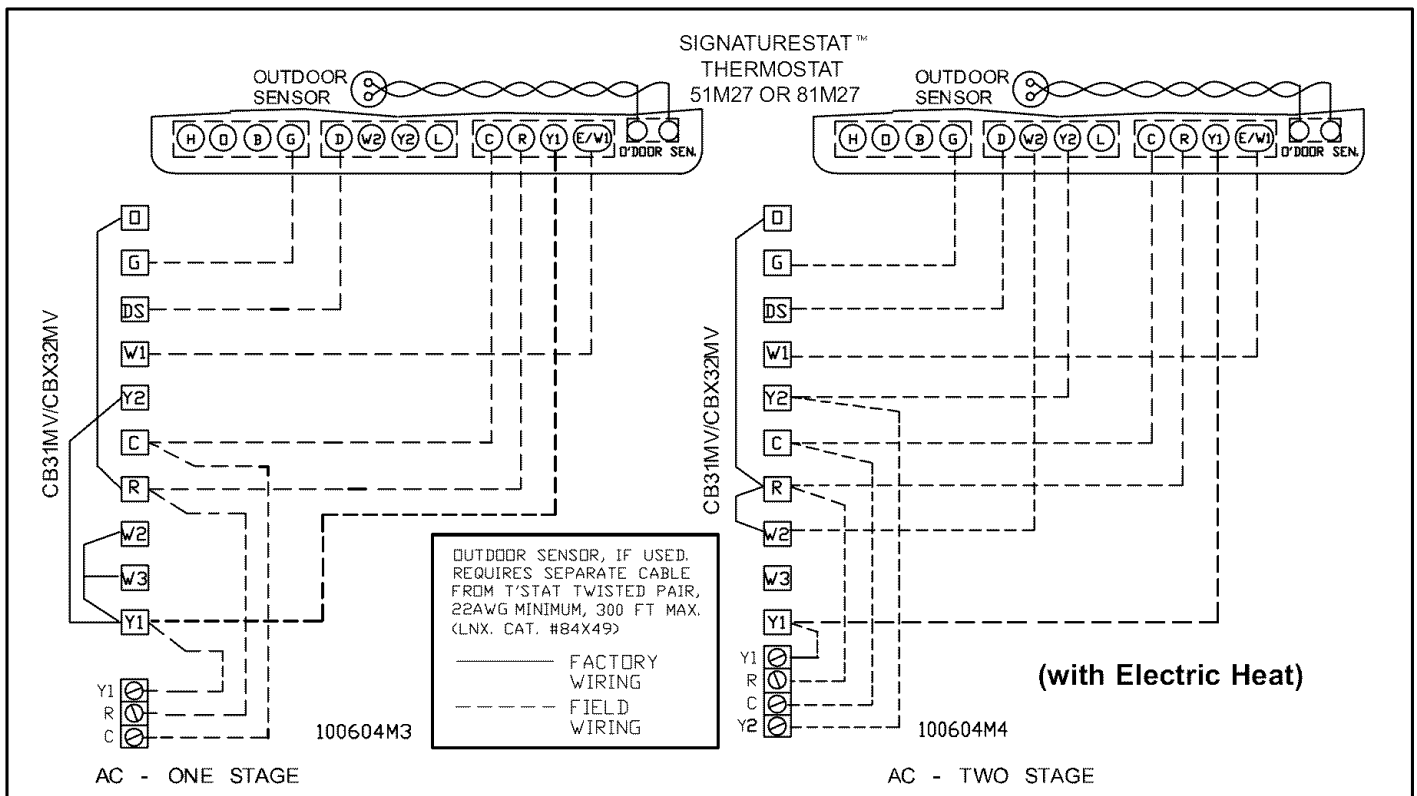

**Figure 15. Field Wiring: Cooling Application**

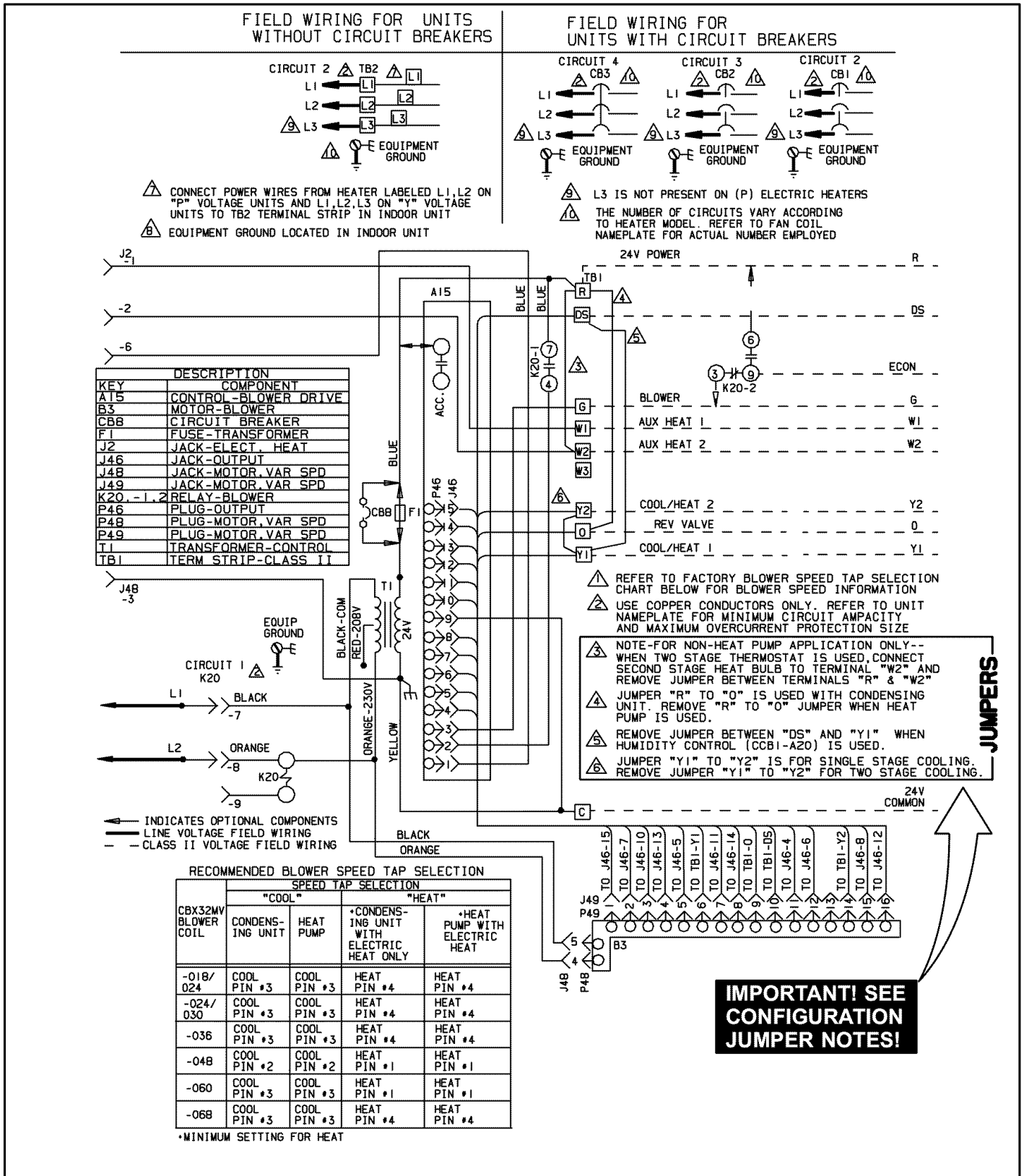

Figure 16. CBX32MV Air Handler Unit Typical Wiring Diagram

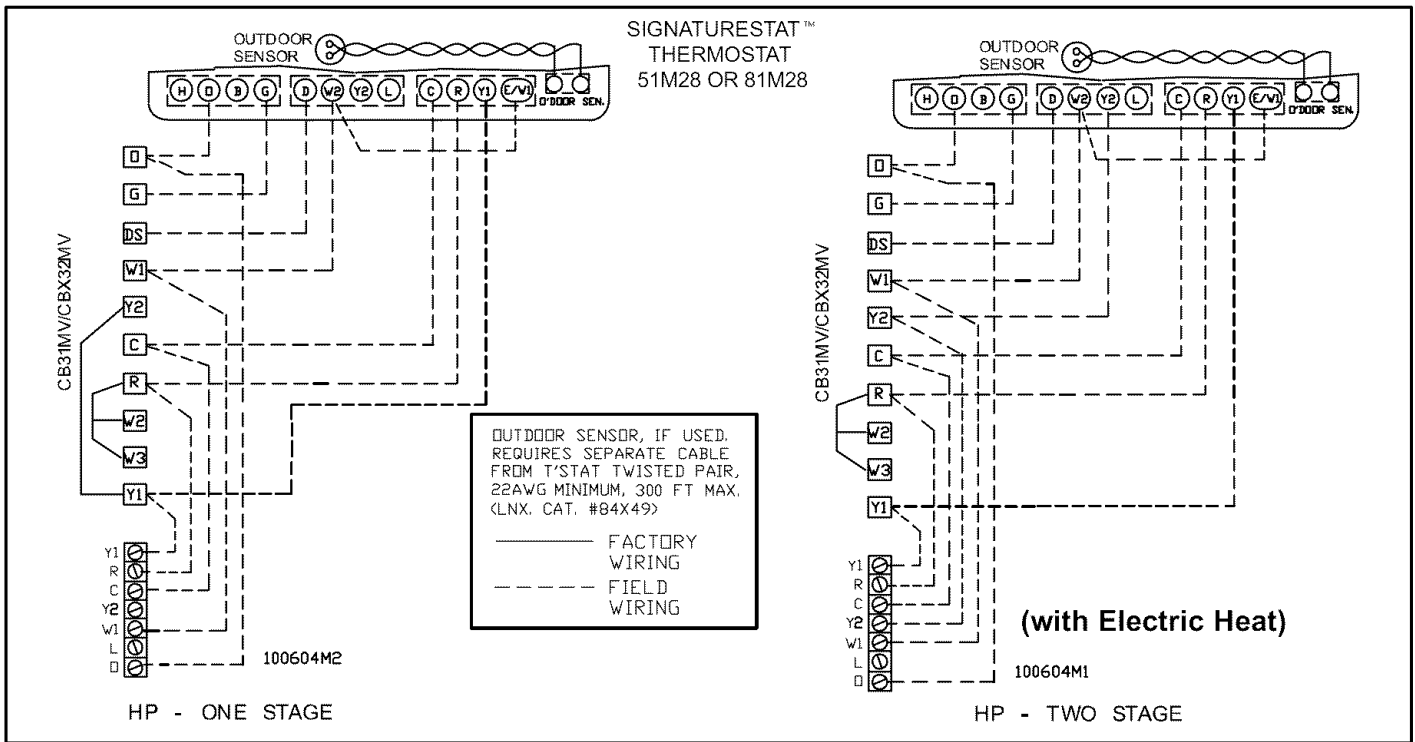

Figure 17. Field Wiring: Heat Pump

**Repairing Cabinet Insulation**

**! IMPORTANT**

**DAMAGED INSULATION MUST BE REPAIRED OR REPLACED** before the unit is put back into operation. Insulation loses its insulating value when wet, damaged, separated or torn.

**! WARNING**

**Electric Shock Hazard.**

**Can cause injury or death.**

**Foil-faced insulation has conductive characteristics similar to metal. Be sure there are no electrical connections within a 1/2" of the insulation. If the foil-faced insulation comes in contact with electrical voltage, the foil could provide a path for current to pass through to the outer metal cabinet. While the current produced may not be enough to trip existing electrical safety devices (e.g. fuses or circuit breakers), the current can be enough to cause an electric shock hazard that could cause personal injury or death.**

Matt or foil-faced insulation is installed in indoor equipment to provide a barrier between outside air conditions (surrounding ambient temperature and humidity) and the varying conditions inside the unit. If the insulation barrier is damaged (wet, ripped, torn or separated from the cabinet walls), the surrounding ambient air will affect the inside surface temperature of the cabinet. The

temperature/humidity difference between the inside and outside of the cabinet can cause condensation on the inside or outside of the cabinet which leads to sheet metal corrosion and subsequently, component failure.

**REPAIRING DAMAGED INSULATION**

Areas of condensation on the cabinet surface are an indication that the insulation is in need of repair.

If the insulation in need of repair is otherwise in good condition, the insulation should be cut in an X pattern, peeled open, glued with an appropriate all-purpose glue and placed back against the cabinet surface, being careful to not overly compress the insulation so the insulation can retain its original thickness. If such repair is not possible, replace the insulation. If using foil-faced insulation, any cut, tear, or separations in the insulation surface must be taped with a similar foil-faced tape.

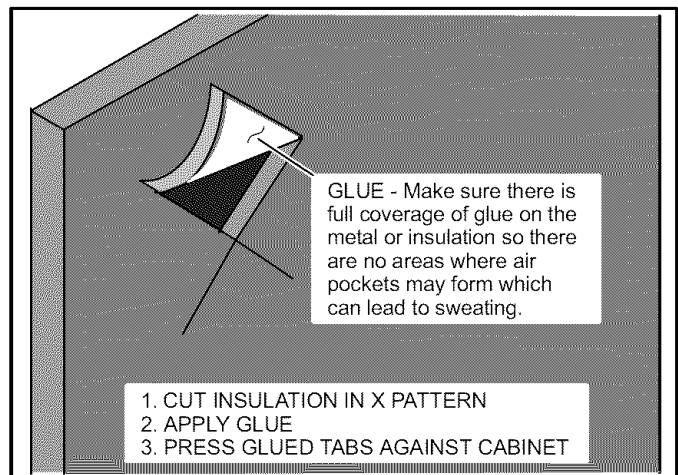

Figure 18. Repairing Insulation