

**INSTALLATION INSTRUCTIONS FOR LOW AMBIENT CONTROL KIT LB-101123C (68M04)
USED WITH: HSXA19-038 & XC21 CONDENSING UNITS;
HPXA19-038 & XP19 HEAT PUMP UNITS**

Shipping & Packing List

Package 1 of 1 contains the following:

- 1 - Low ambient pressure switch assembly 83L6001 (S11)
- 2 - Relays - part #69J8001 (K58 and K159)
- 10 - 20" Lengths of wire (c/w 3/16" Female quick connects on one end of each wire)
- 10 - Wire nuts
- 4 - #10-16 X 5/8" S.D.S.T. screws
- 1 - Schrader depressor tee with seal cap

Ordered separately:

- 1 - Properly sized freezestat (S49)

⚠ IMPORTANT

Improper installation, adjustment, alteration, service or maintenance can cause property damage, personal injury or loss of life. Installation and service must be performed by a qualified installer or service agency.

Application

The low ambient control pressure switch (S11) cycles the outdoor fan, while allowing continuous compressor operation during a cooling demand. This intermittent outdoor fan operation maintains a minimum pressure differential across the expansion device as the ambient temperature drops, thus reducing capacity losses during low ambient conditions. The freezestat (ordered separately) senses suction line temperature and cycles the compressor off when suction line temperature falls below its setpoint. This kit is designed for use in ambient temperatures that are no lower than 30°F (-1°C) unless otherwise noted in the Engineering Handbook. Use this kit only with HSXA19-038, XC21, HPXA19-038, or XP19 units in R410A refrigerant applications.

NOTE - This kit may be applied in expansion valve systems only. It is not suitable for use in systems which use capillary tube metering devices.

All units are factory-equipped with a crankcase heater.

Installation

- 1 - Turn off the electrical power to the unit.
- 2 - Remove compressor compartment access panel, if applicable.
- 3 - Install provided low ambient pressure switch on open port (no valve core) of provided tee fitting.
NOTE - Pressure switch must be installed before tee is installed to avoid refrigerant loss.
- 4 - Install tee fitting on condensing unit liquid line service port.
- 5 - Install cap on valve core port and tighten to 6 to 8 ft.-lbs.
- 6 - Route pressure switch wires into control box and connect per applicable unit wiring diagram.
- 7 - A freezestat, sized per table 1 and ordered separately, must be installed. Install the freezestat near the evaporator coil discharge line (on the last 5/16" or 3/8" bend of the indoor coil) or on the suction line.

Table 1

Freezestat Selection			
Tubing Size	Wire Length	Wire Gauge	Lennox Part No.
3/8"	90-13/16"	18	93G35
1/2"	140-13/16"	18	39H29
5/8"	36-1/2"	18	50A93

8 - **HSXA19-038 and XC21 Units** - Use the two provided screws to install the provided K159 relay in the control box.

HPXA19-038 and XP19 Units - Use the four provided screws to install the provided K58 and K159 relays in the control box.

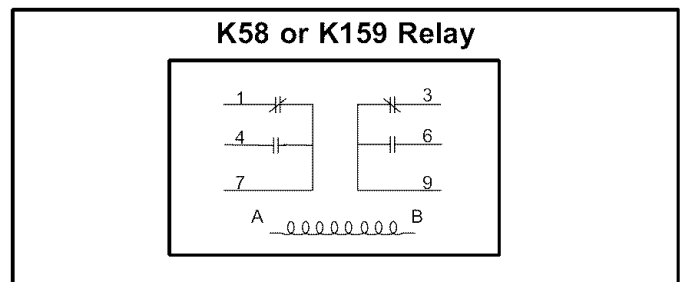

Figure 1



Wire Connections

Complete the wiring connections per the appropriate wiring diagram. See figures 2 through 5.

Switch Settings

The provided low ambient pressure switch is factory set for 450 psig (3100 kPa) cut-in and 240 psig (1600 kPa) cut-out. This switch is not adjustable.

The freezestat (ordered separately) will open at 29°F (-2°C) and close at 58°F (10°C). See table 1.

NOTE: Use ONLY expansion valve metering devices on units with low ambient kits.

Operational Checkout

Cooling Mode

HSXA19-038 and XC21 Units

Set the room thermostat to call for cooling. The unit will receive a Y signal from the room thermostat through the field mounted freeze thermostat. The compressor will cycle ON. The outdoor fan will be OFF until the liquid line pressure reaches the ON setting (450 psig - 3100kPa) of the low ambient. The low ambient pressure switch (S11) contacts will close, and the K159 relay coil will be energized. K159-1 relay contacts will close, and the outdoor fan motor will cycle ON.

NOTE - The outdoor fan motor will be cycled by the low ambient and K159 relay. During a call for cooling when the liquid line pressure rises above 450 psig (3100 kPa), the outdoor fan will cycle ON. When the liquid line pressure falls below 240 psig (1600 kPa), the outdoor fan will cycle OFF.

HPXA19-038 and XP19 Units

Set the room thermostat to call for cooling. The defrost board in the unit will receive a Y and O signal from the room thermostat. The O signal will energize the reversing valve and the K58 relay coil. Contacts K58-1 will open. The Y signal will go through the freeze stat to Y1 on the defrost board. The signal will go into defrost board to the HI-PS terminals, out to the high pressure switch and discharge thermostat, then back to the other HI-PS terminal. The signal will come back out of the defrost board on the Y terminal, which will energize the compressor contactor coil. The compressor will cycle ON. The outdoor fan motor will be OFF until the liquid line pressure reaches the setting of the low ambient pressure switch (450 psig - 3100kPa). The low ambient pressure switch will close and K159 relay coil will be energized. K159-1 contacts will close and the outdoor fan motor will cycle ON.

NOTE - The outdoor fan motor will be cycled by the low ambient and K159 relay. During a call for cooling when the liquid line pressure rises above 450 psig (3100 kPa), the outdoor fan will cycle ON. When the liquid line pressure falls below 240 psig (1600 kPa), the outdoor fan will cycle OFF.

Heating Mode

HPXA19-038 and XP19 Units

Set the room thermostat to call for heating. The defrost board in the unit will receive a Y signal from the room thermostat. The O signal from the room thermostat is not energized, so the K58 relay coil will not be energized. Contacts K58-1 will remain closed. The Y signal will go through the freeze stat to Y1 on the defrost board. The signal will go into defrost board to the HI-PS terminals, out to the high pressure switch and discharge thermostat and back to the other HI-PS terminal. The signal will come back out of the defrost board on the Y terminal which will energize the compressor contactor coil. The compressor will cycle ON. The K58-1 relay contacts (which are normally closed) will prevent the low ambient pressure switch from interrupting the outdoor fan motor operation during the heating mode.

HSXA19-038 Wiring Diagram

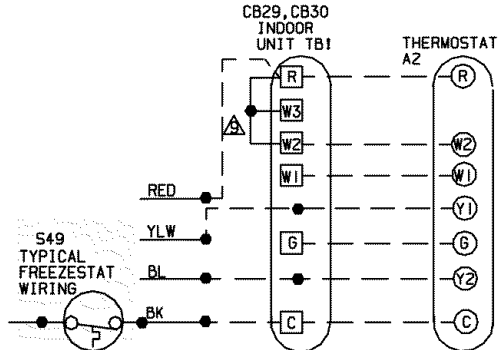
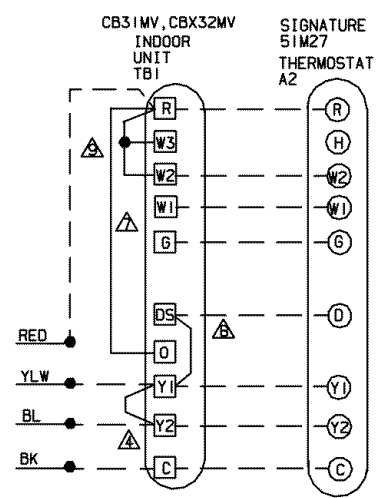
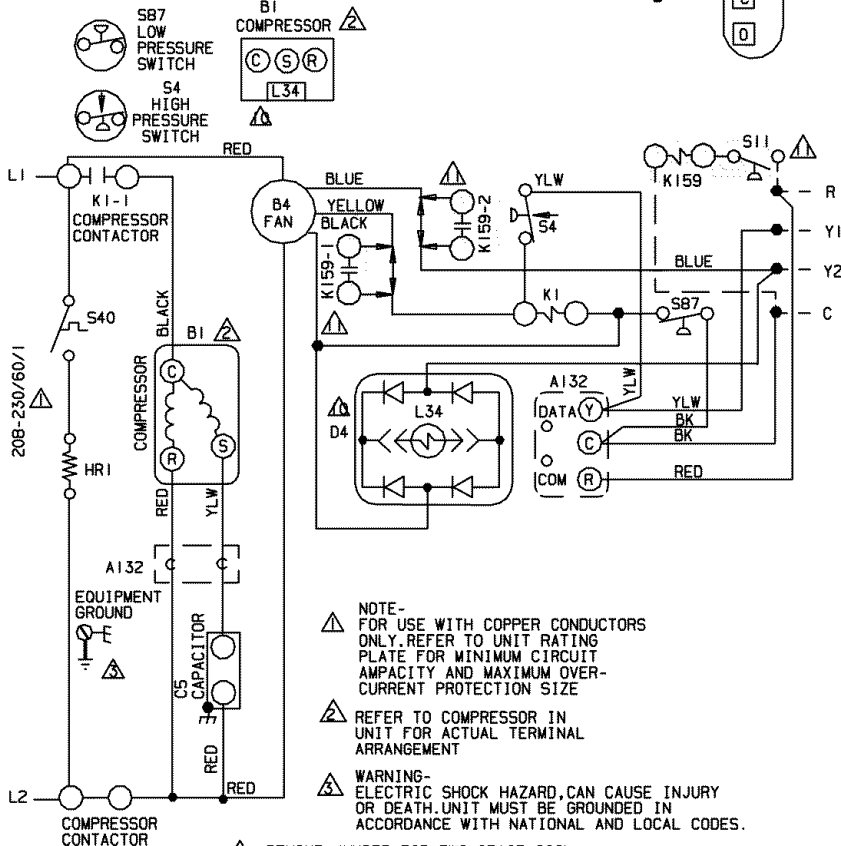
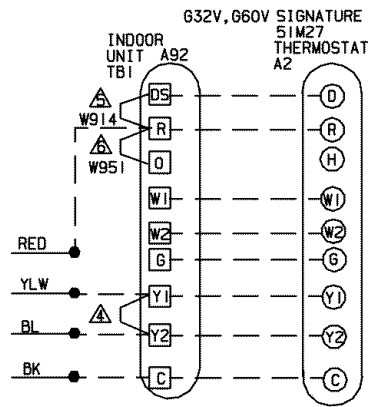
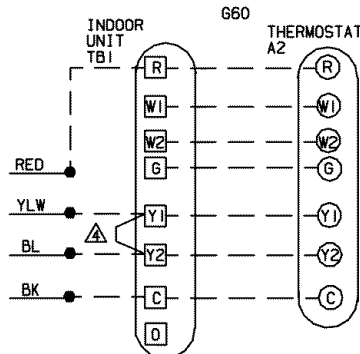
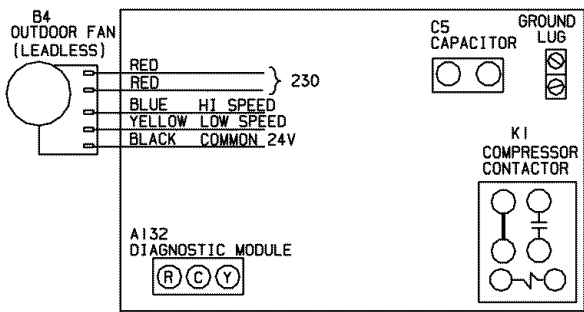

⚠ NOTE - FOR USE WITH COPPER CONDUCTORS ONLY. REFER TO UNIT RATING PLATE FOR MINIMUM CIRCUIT AMPACITY AND MAXIMUM OVER-CURRENT PROTECTION SIZE

⚠ REFER TO COMPRESSOR IN UNIT FOR ACTUAL TERMINAL ARRANGEMENT

⚠ WARNING - ELECTRIC SHOCK HAZARD, CAN CAUSE INJURY OR DEATH. UNIT MUST BE GROUNDED IN ACCORDANCE WITH NATIONAL AND LOCAL CODES.

- ⚠ REMOVE JUMPER FOR TWO STAGE COOL
 - ⚠ ON A92 CUT ONBOARD W914 JUMPER FROM DS TO R, WHEN HUMIDITY CONTROL IS USED
 - ⚠ ON A92 DO NOT CUT ONBOARD W951 JUMPER FROM R TO O. IT IS USED FOR APPLICATIONS FOR CONDENSING UNITS
 - ⚠ FOR CONDENSING UNIT APPLICATIONS USE R TO O JUMPER. REMOVE IN HEAT PUMP APPLICATIONS.
 - ⚠ REMOVE DS TO Y1 JUMPER WHEN HUMIDITY CONTROL IS USED
 - ⚠ WHEN TWO STAGE THERMOSTAT IS USED, CONNECT SECOND STAGE HEAT BULB TO TERMINAL "W2" AND REMOVE JUMPER BETWEEN "R" AND "W2"
 - ⚠ L34 SOLENOID IS LOCATED IN COMPRESSOR. COIL IS 24 VDC, DO NOT CONNECT 24VAC TO COIL TERMINALS.
 - ⚠ S11, K159 AND K58 ARE OPTIONAL LOW AMBIENT CONTROLS
- NOTE: MINIMUM TRANSFORMER REQUIRED IN INDOOR UNIT-40 VA

— INDICATES OPTIONAL COMPONENTS
 — LINE VOLTAGE FIELD INSTALLED
 - - - CLASS II VOLTAGE FIELD INSTALLED

GE VARIABLE FAN MOTOR (B4)

LENNOX COOLING UNITS- CONDENSING UNITS	
LOW AMBIENT KIT FOR HSXA19-038-230-02	
0506	Supersedes Form No.
	New Form No.
	534,451W

Figure 2

XC21 Wiring Diagram

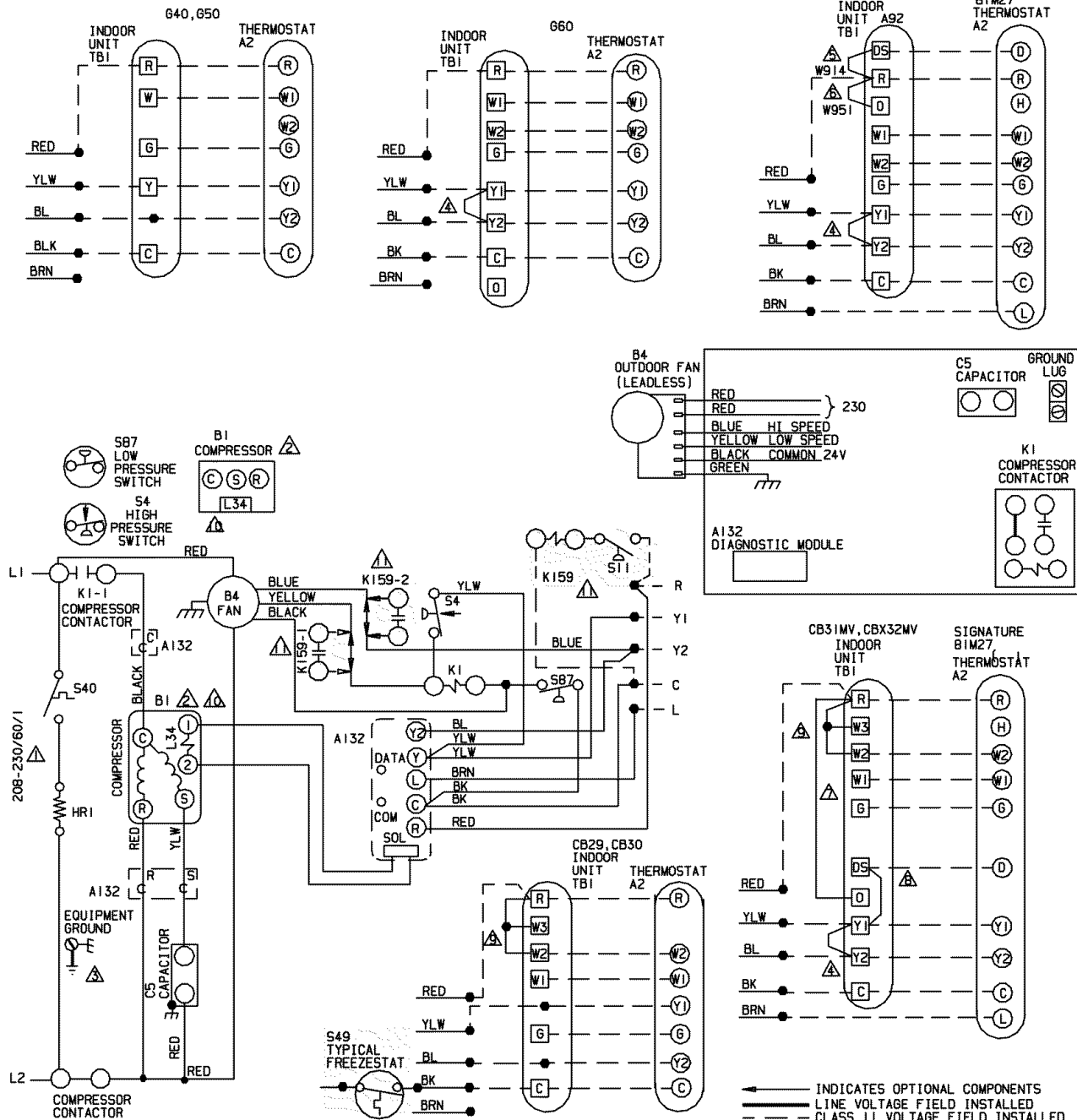

- ⚠ NOTE-FOR USE WITH COPPER CONDUCTORS ONLY, REFER TO UNIT RATING PLATE FOR MINIMUM CIRCUIT AMPACITY AND MAXIMUM OVERCURRENT PROTECTION SIZE
 - ⚠ REFER TO COMPRESSOR IN UNIT FOR ACTUAL TERMINAL ARRANGEMENT
 - ⚠ WARNING-ELECTRIC SHOCK HAZARD, CAN CAUSE INJURY OR DEATH. UNIT MUST BE GROUNDED IN ACCORDANCE WITH NATIONAL AND LOCAL CODES.
 - ⚠ REMOVE JUMPER FOR TWO STAGE COOL
 - ⚠ ON A92 CUT ONBOARD W914 JUMPER FROM DS TO R, WHEN HUMIDITY CONTROL IS USED
 - ⚠ ON A92 DO NOT CUT ONBOARD W951 JUMPER FROM R TO O. IT IS USED FOR APPLICATIONS FOR CONDENSING UNITS
 - ⚠ FOR CONDENSING UNIT APPLICATIONS USE R TO O JUMPER. REMOVE IN HEAT PUMP APPLICATIONS.
 - ⚠ REMOVE DS TO Y1 JUMPER WHEN HUMIDITY CONTROL IS USED
 - ⚠ WHEN TWO STAGE THERMOSTAT IS USED, CONNECT SECOND STAGE HEAT BULB TO TERMINAL "W2" AND REMOVE JUMPER BETWEEN "R" AND "W2"
 - ⚠ L34 SOLENOID IS LOCATED IN COMPRESSOR. COIL IS 24 VDC. DO NOT CONNECT 24VAC TO COIL TERMINALS.
 - ⚠ OPTIONAL LOW AMBIENT CONTROLS
- NOTE: MINIMUM TRANSFORMER REQUIRED IN INDOOR UNIT-40 VA

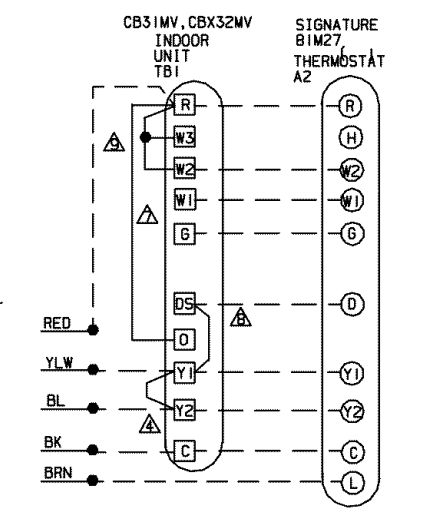
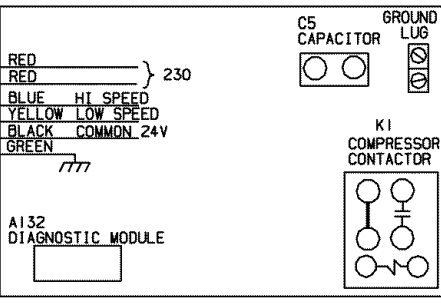
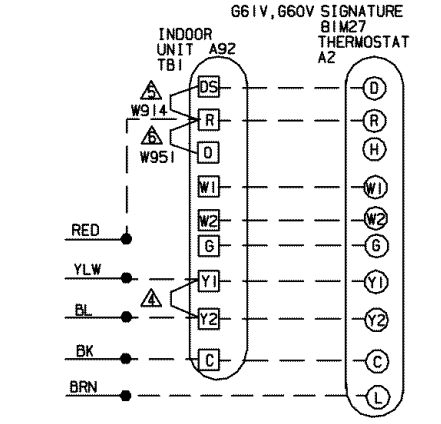

← INDICATES OPTIONAL COMPONENTS
 --- LINE VOLTAGE FIELD INSTALLED
 -.- CLASS II VOLTAGE FIELD INSTALLED

LENNOX		COOLING UNITS- CONDENSING UNITS
XC21-024-230 XC21-036-230 XC21-048-230 XC21-060-230		
		Supersedes Form No. 0406
		New Form No. 534,862W

Figure 3

HPXA19-038 Wiring Diagram

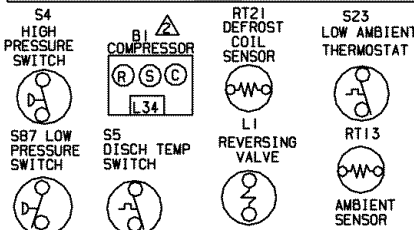
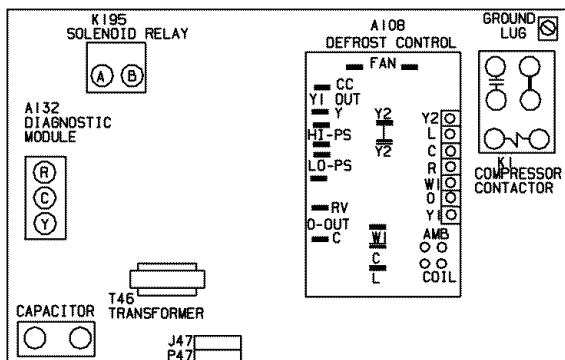

NOTE- FOR USE WITH COPPER CONDUCTORS ONLY. REFER TO UNIT RATING PLATE FOR MINIMUM CIRCUIT AMPACITY AND MAXIMUM OVER-CURRENT PROTECTION SIZE.

REFER TO COMPRESSOR IN UNIT FOR ACTUAL TERMINAL ARRANGEMENT.

WARNING- ELECTRIC SHOCK HAZARD. CAN CAUSE INJURY OR DEATH. UNIT MUST BE GROUNDED IN ACCORDANCE WITH NATIONAL AND LOCAL CODES.

REMOVE JUMPER FOR TWO STAGE COOL

RT14 SENSOR, OUTDOOR TEMP (OPTIONAL)

S23 CLOSES AT LOW AMBIENT TEMPERATURES TO OPERATE SECOND STAGE COMPRESSOR ON HEATING

L34 SOLENOID IS LOCATED IN COMPRESSOR, COIL IS 24VDC. DO NOT CONNECT 24VAC TO COIL TERMINALS

S11, K159 AND K58 ARE OPTIONAL LOW AMBIENT CONTROLS

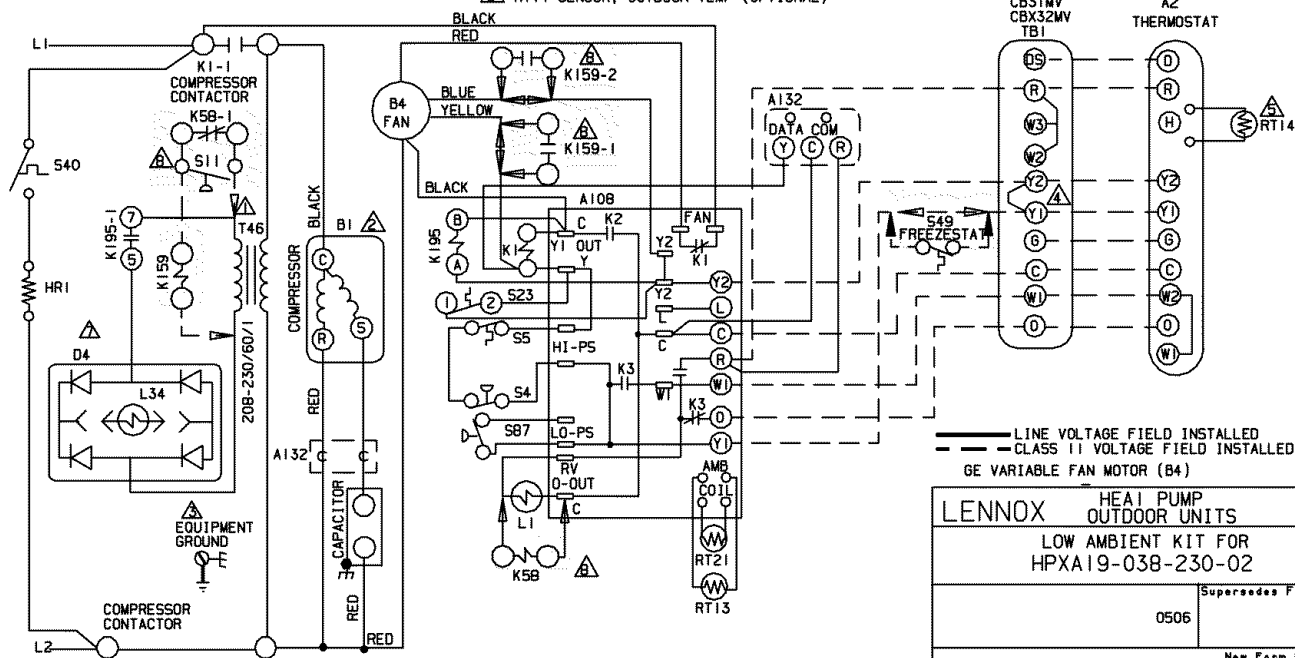

— LINE VOLTAGE FIELD INSTALLED
 - - - CLASS II VOLTAGE FIELD INSTALLED
 GE VARIABLE FAN MOTOR (B4)

LENNOX	
HEAT PUMP OUTDOOR UNITS	
LOW AMBIENT KIT FOR HPXA19-038-230-02	
0506	Supersedes Form No.
New Form No. 534,452W	

©2006 Lennox Industries Inc.

Li the U.S.A.

Figure 4

