

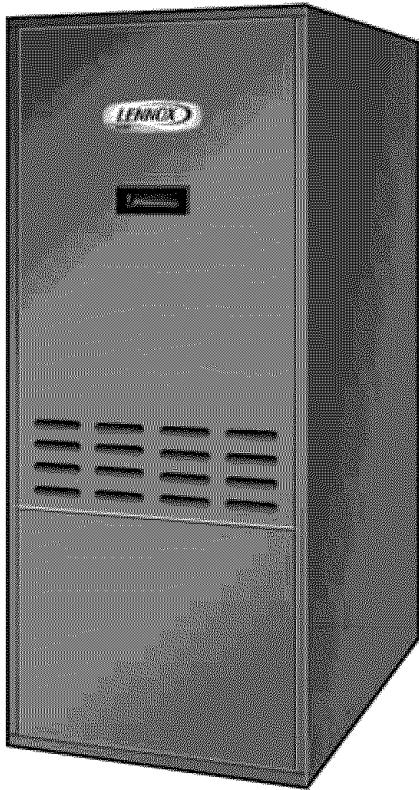

© 2005 Lennox Industries Inc.
Dallas, Texas, USA

INSTALLATION INSTRUCTIONS

O25 SERIES UNITS



OIL UNITS
505,149M
38152A075
12/2005

TP Technical
Publications
Litho U.S.A.

Table of Contents

General	1
Shipping & Packing	1
O25 Unit Dimensions	2
O25 Unit Parts Arrangement	3
O25 Riello Oil Burner Parts Arrangement	3
Locate & Level the Unit	4
Unit Set-Up	4
Requirements	6
Venting	9
Flue Connections	10
Supply & Return Air Plenums	12
Oil Supply Piping	12
Leak Check	14
Electrical Wiring	15
Pump Purging	16
Unit Start-Up & Adjustments	16
Service	17
O25 Start-Up & Performance Check List	18

⚠ CAUTION

When venting this appliance, keep vent terminal free of snow, ice and debris.

General

These instructions are intended as a general guide and do not supersede local codes in any way. Only qualified technicians can install and service the Lennox Elite® Series O25 oil furnaces. In Canada, refer to CSA B139 for recommended installation procedures. Consult authorities who have jurisdiction before installation.

**RETAIN THESE INSTRUCTIONS
FOR FUTURE REFERENCE**

⚠ WARNING

Do not store or use gasoline or other flammable vapors and liquids in the vicinity of this or any other appliance.

⚠ CAUTION

Never burn garbage or paper in the heating system. Never leave papers near or around the unit.

⚠ WARNING

Improper installation, adjustment, alteration, service, or maintenance can cause injury or property damage. Refer to this manual. For assistance or additional information, consult a qualified installer or service agency.

Shipping & Packing List

- 1 - Assembled oil furnace
- 1 - Barometric draft control
- 1 - Bypass plug (used on two oil line lift systems)
- 1 - Side filter adapter kit (includes filter)
- 1 - Return line adapter

Check the components for shipping damage. If you find any damage, immediately contact the last carrier.

12/05

505,149M



O25 Unit Dimensions - Inches (mm)

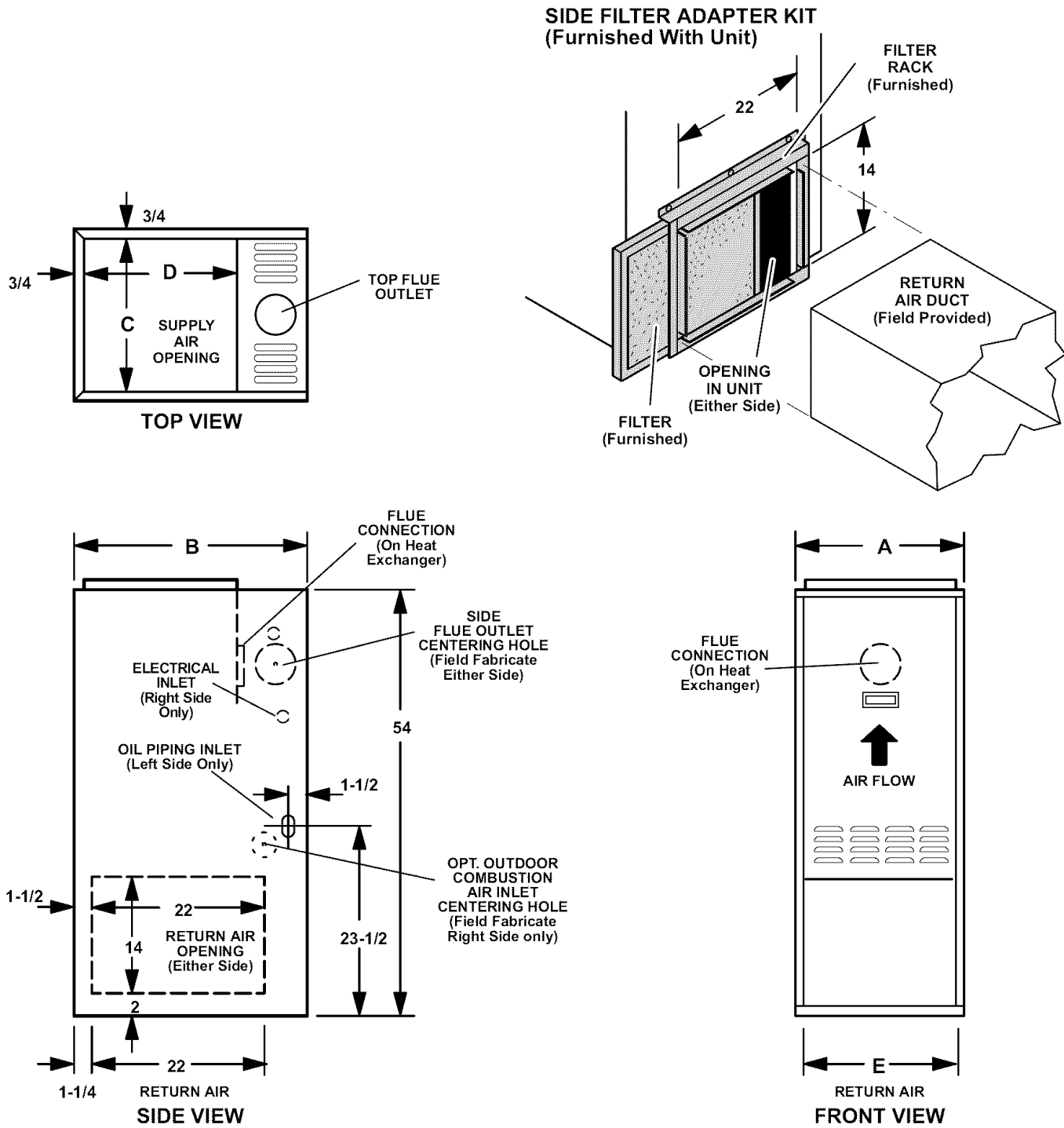

Model No.	A	B	C	D	E
O25Q2-80	19-1/2	30-5/8	18	19-5/8	16
O25Q2/3-105/120					
O25Q3/4-140/154	22-1/2	33-1/8	21	22-1/8	18

O25 Unit Parts Arrangement

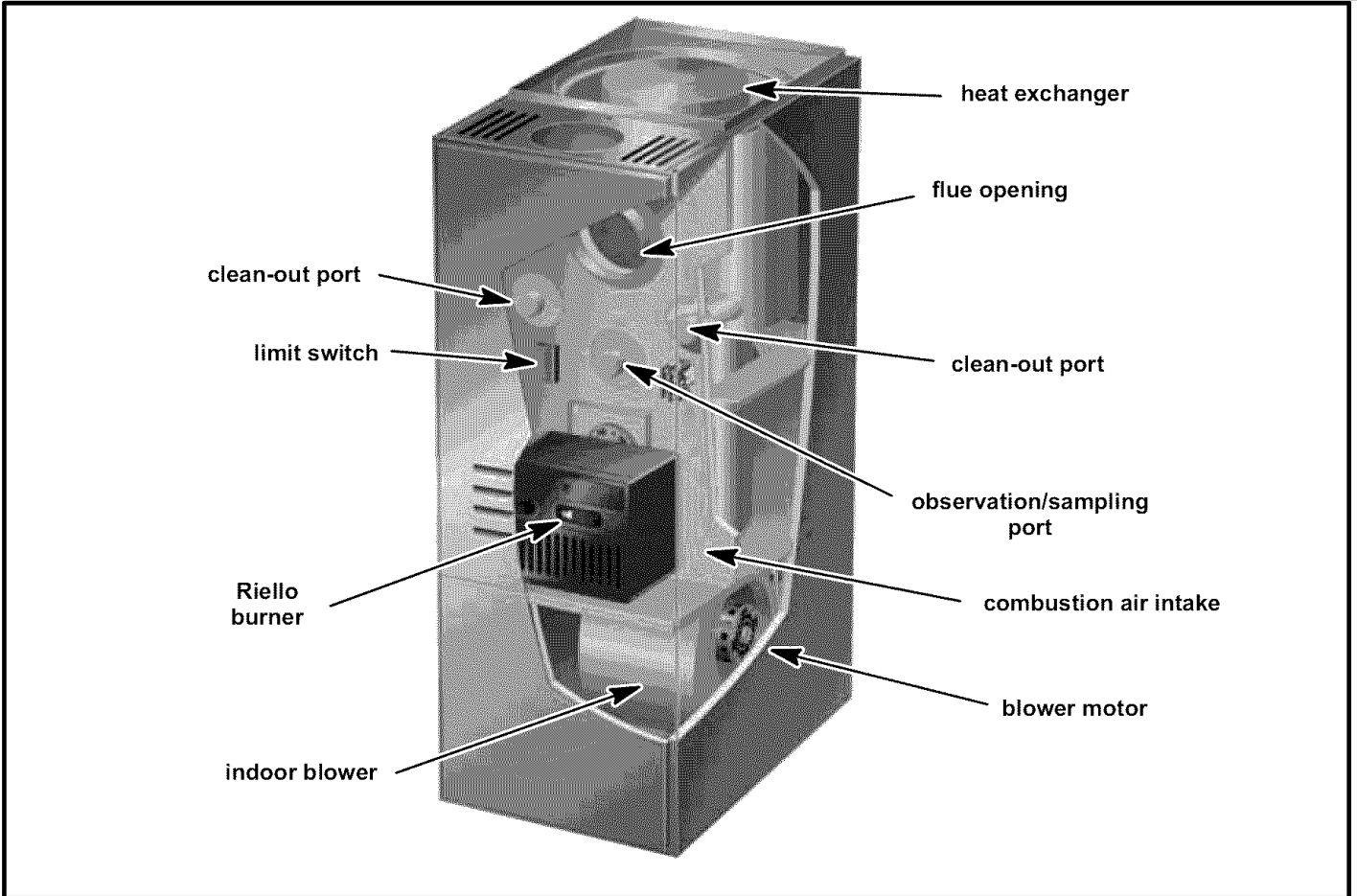

Figure 1

O25 Riello Oil Burner Parts Arrangement

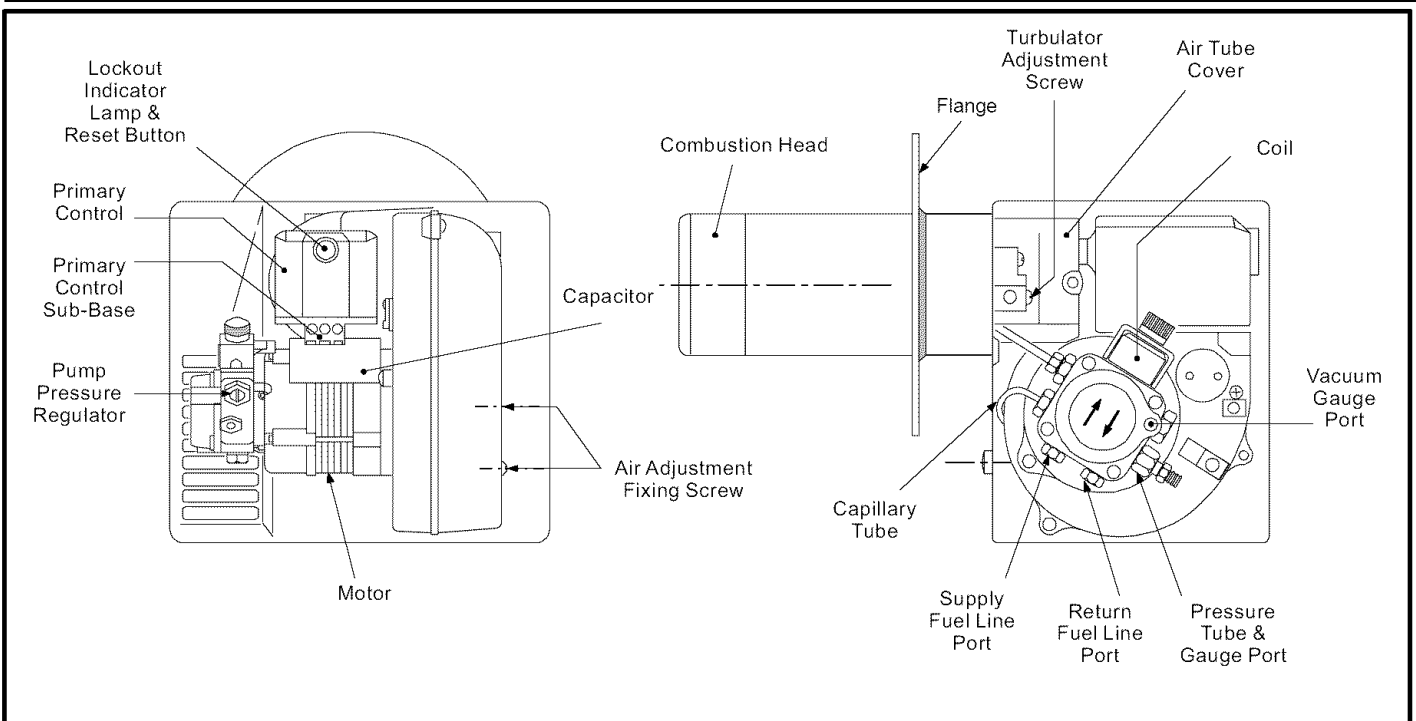

Figure 2

Locate & Level the Unit

- 1 - Set the unit in desired location keeping in mind the clearances listed in table 2. Also keep in mind oil supply connections, electrical supply, flue connections and sufficient clearance for installing and servicing unit.
- 2 - Level the unit from side to side and from front to rear. If the furnace is not level, place fireproof wedges or shims between the low side of the furnace and the floor. Make sure the weight of the furnace is distributed evenly on all four corners. Strain on sides of cabinet causing cracking and popping noises may occur if weight of furnace is not evenly distributed.

WARNING

If the unit is installed where damage from oil may occur, a drain pan must be installed. The drain pan must be large enough to completely prevent any potential oil damage. The drain pan piping must be sized to drain the oil pump. The piping must be routed to drain the oil back into the oil tank.

Unit Set-Up

Input Selection

- 1 - Determine the desired furnace firing rate. Use table 1 to select the proper nozzle and pump pressure required to obtain the desired input from the burner. If necessary, replace the nozzle to achieve the higher input rate.
- 2 - Remove the oil burner cover.
- 3 - Locate drawer assembly. Loosen screw which holds control box in place. Remove control box by carefully pulling it back and then up. See figure 3.
- 4 - Loosen the screw(s) which secure the air tube cover plate. Remove the air tube cover plate.
- 5 - Loosen the screw which secures the drawer assembly in place. Slide the drawer assembly out of the combustion head as shown in figure 3.
- 6 - Remove the screw as shown in figure 4 and slide the nozzle adapter from the drawer assembly.

- 7 - Insert the proper nozzle into the adapter. Tighten the nozzle securely; however, do not overtighten.
- 8 - Reverse steps to re-assemble burner.

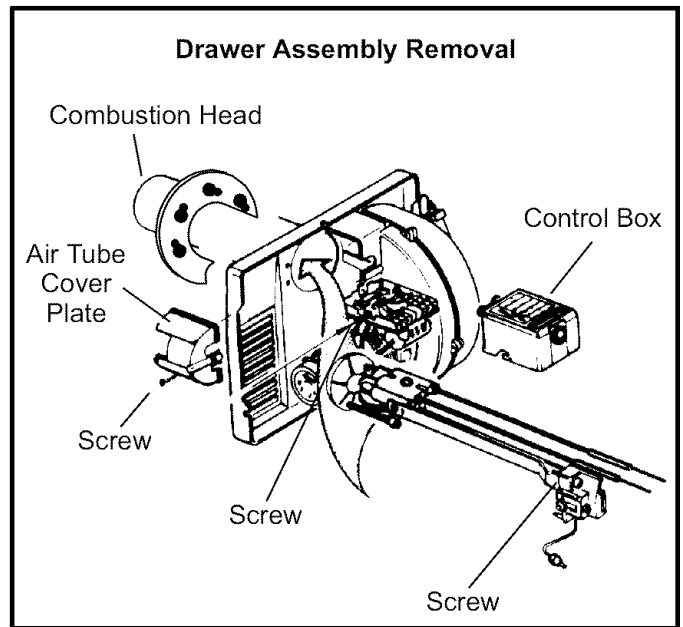

FIGURE 3

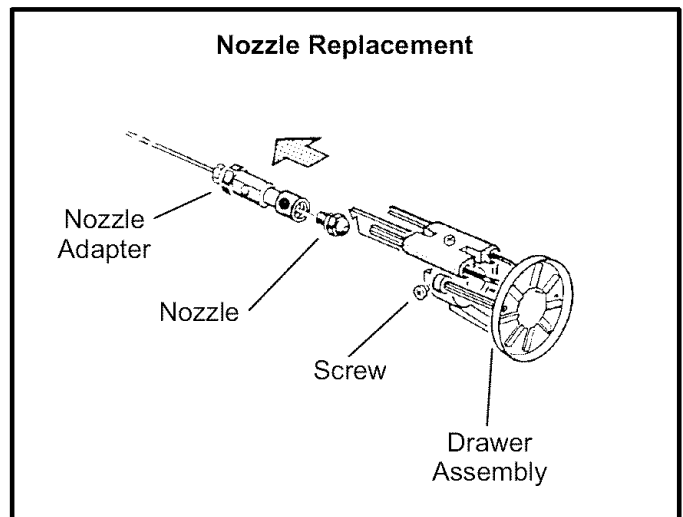

FIGURE 4

**Table 1
Burner Set-Up**

Furnace Model	Riello Burner Model	Fuel Input Rating		Nozzle Angle	Pump Pressure (Psig)	Air Adj Plate Setting (Index)	Turbulator Setting (Index)
		Gph	Btu/Hr.				
80 ₁	F3	0.60	80,000	0.50 x 80° B ₃	135	2.0	2.0
105/120 ₁	F3	0.75	105,000	0.65 x 80° B	140	3.0	2.0
105/120 ₂	F3	0.85	119,000	0.75 x 80° B	140	3.5	2.0
140/154 ₁	F5	1.00	140,000	0.85 x 80° B	140	2.5	2.0
140/154 ₂	F5	1.10	154,000	1.00 x 80° B	140	3.0	2.0

1. Denotes factory default burner configuration as shipped
2. Denotes optional firing rate and burner configuration
3. Delavan nozzle type Del-o-Flo 0.50 X 80°B (Only for O25Q2-80)
4. All other nozzles type B -- Delavan
5. All burner preset and configured for single line gravity-fed oil supply system

Electrode Gap Verification

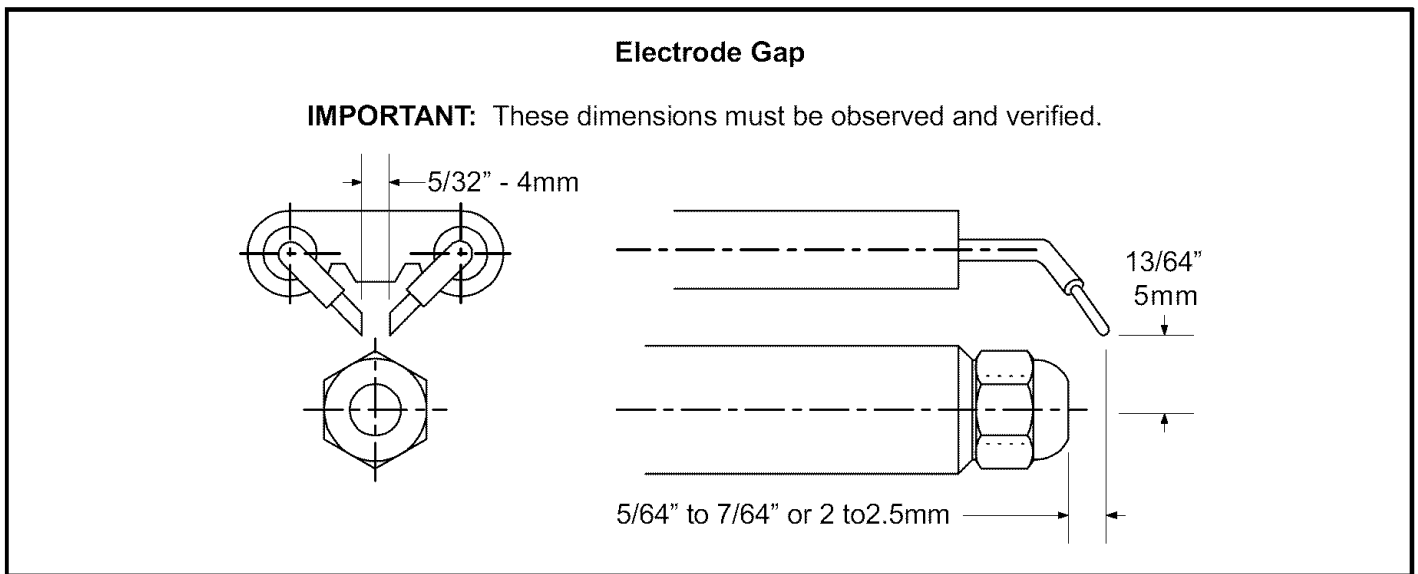

Figure 5

Turbulator Setting

- 1 - Loosen nut and turn screw until index marker is aligned with number 2, which corresponds with desired input setting per table 1. See figure 6.
- 2- Retighten retaining nut.

NOTE - Scale on F3 burner is 3 to 0. Scale on F5 burner is 4 to 0.

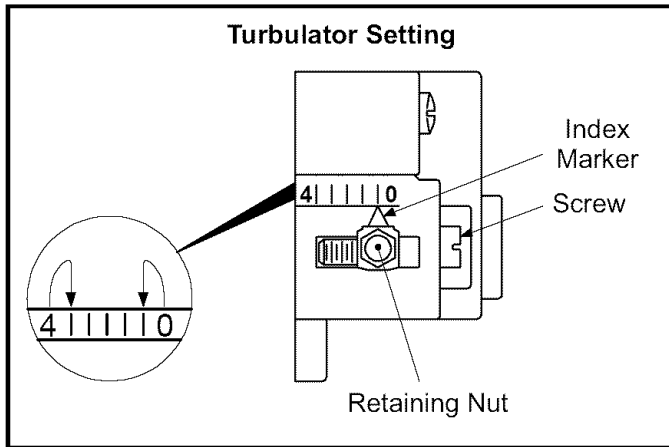

FIGURE 6

Air Adjustment Plate Positioning

The initial adjustment of the air adjustment plate should match the value given in table 1 which corresponds with the desired input.

- 1 - Loosen the two screws which secure the plate in position. See figure 6.
- 2- Turn the air adjustment plate until the desired value given in table is aligned with the setting indicator on the fan housing cover. Retighten two securing screws.

NOTE - Air adjustment plate may need additional positioning at unit start-up to ensure proper unit operation.

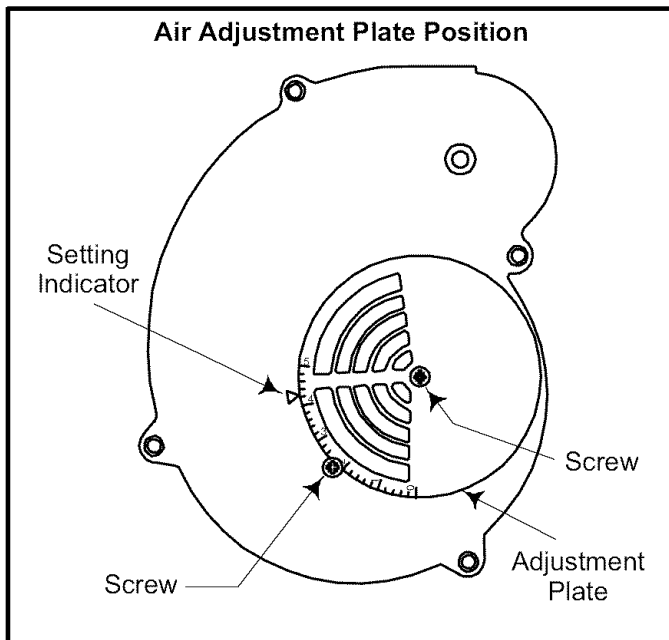

FIGURE 7

Requirements

⚠ WARNING

Product contains fiberglass wool.

Disturbing the insulation in this product during installation, maintenance, or repair will expose you to fiberglass wool dust. Breathing this may cause lung cancer. (Fiberglass wool is known to the State of California to cause cancer.)

Fiberglass wool may also cause respiratory, skin, and eye irritation.

To reduce exposure to this substance or for further information, consult material safety data sheets available from address shown below, or contact your supervisor.

Lennox Industries Inc.

P.O. Box 799900

Dallas, TX 75379-9900

⚠ WARNING

Improper installation, adjustment, alteration, service or maintenance can cause property damage, personal injury or loss of life. Installation and service must be performed by a qualified installer or service agency.

Installation of Lennox oil-fired furnaces must conform with the National Fire Protection Association Standard for the Installation of Oil Burning Equipment, NFPA No. 31, the National Electrical Code, ANSI/NFPA No.70 (in the U.S.A.), CSA Standard CAN/CSA-B139 (in Canada), Installation Code for Oil Burning Equipment, the Canadian Electrical Code Part1, CSA 22.1 (Canada), the recommendations of the National Environmental Systems Contractors Association and any state or provincial laws or local ordinances. Authorities having jurisdiction should be consulted before installation. Such applicable regulations or requirements take precedence over general instructions in this manual.

Chimneys and chimney connectors must be of the type and construction outlined in section 160 of NFPA No. 31.

Clearances

This unit is approved for use on combustible flooring and for clearances to combustible material as listed on unit rating plate and in table 2. **Unit service and accessibility clearances take precedence over fire protection clearances.**

Table 2
Installation Clearances inches (mm)

Clearances	80/ 105/120
Top of plenum and duct	2 (51)
Plenum sides	3 (76)
Furnace sides	0 (0)
Furnace rear	0 (0)
Front of access panel	4 (120)
Flue pipe**	6 (152)

NOTE - Service access clearance of 24" in the front of the unit must be maintained to accommodate burner service.

**A passage, suitable for a large person, shall be provided between the furnace and chimney for inspection or replacement of the flue collector when necessary. A clearance of 24" shall be allowed at the rear and on one side of the furnace for service and floor cleaning of the blower.*

***Minimum clearance shown for flue pipe may be reduced by using special protection as provided by local building codes and the National Fire Protection Association Standards.*

Temperature Rise

Unit must be adjusted to obtain a temperature rise in the range listed on the unit rating plate.

When installed, furnace must be electrically grounded in accordance with local codes or, in the absence of local codes, with the current National Electric Code, ANSI/NFPA No. 70, or Canadian Electric Code (CEC) if an external electrical source is utilized.

Field Wiring

Field wiring connections must meet or exceed specifications of type T wire and withstand a 63°F (17°C) temperature rise.

Cooling Applications

When furnace is used in conjunction with cooling units, it shall be installed in parallel with, or on the upstream side of, cooling units to avoid condensation in the heating element. With a parallel flow arrangement, a damper (or other means to control the flow of air) shall be adequate to prevent chilled air from entering the furnace and, if manually operated, must be equipped with means to prevent operation of either unit, unless damper is in the full "heat" or "cool" position.

Combustion and Ventilation Air (Confined and Unconfined Spaces)

In the past, there was no problem in bringing in sufficient amounts of outdoor air for combustion - infiltration provided all the air that was needed and then some. In today's homes built with energy conservation in mind, tight construction practices make it necessary to bring in air from outside for combustion. Consideration must also be given to the use of exhaust fans, appliance vents, chimneys and fireplaces because they force additional air that could be used for combustion out of the house. Unless outside air is brought into the home for combustion, negative

pressure (pressure outside is greater than inside pressure) will build to the point that a down draft can occur in the furnace vent pipe or chimney. Combustion gases enter the living space creating a potentially dangerous situation.

The importance of the previous paragraph cannot be overstated. Users may inadvertently block fresh air intakes after installation.

In the absence of local codes concerning air for combustion and ventilation, the following section outlines guidelines and recommends procedures for operating oil furnaces in a manner that ensures efficient and safe operation. Special consideration must be given to combustion air needs as well as requirements for exhaust vents and oil piping.

Combustion Air Requirements

CAUTION

Insufficient combustion air can cause headaches, nausea, dizziness or asphyxiation. It will also cause excess water in the heat exchanger resulting in rusting and premature heat exchanger failure. It can also cause property damage.

All oil-fired appliances require air to be used for the combustion process. If sufficient amounts of combustion air are not available, the furnace or other appliance will operate in an inefficient and unsafe manner. Enough air must be provided to meet the needs of all fuel-burning appliances, as well as appliances such as exhaust fans which force air out of the home. When fireplaces, exhaust fans, or clothes dryers are used at the same time as the furnace, much more air is required to ensure proper combustion and to prevent a down-draft situation. Insufficient amounts of air also cause incomplete combustion which can result in sooting. Requirements for providing air for combustion and ventilation depend largely on whether the furnace is installed in an unconfined or confined space.

Air for combustion and ventilation must conform to standards outlined in section 140 of NFPA No. 31 or, in Canada, CSA Standard B139. When installing O25 units in confined spaces such as utility rooms, two combustion air openings are required. Dimensions of combustion air openings are shown in table 3. One opening shall be within 12" of the ceiling and the other opening shall be within 12" of the floor.

IMPORTANT

An opening to the outside for combustion air is strongly recommended, especially in new homes. Refer to table 2 or the unit rating plate for specific combustion air opening dimensions.

The combustion air opening should provide a minimum free area one-half square inch per 1,000 Btu per hour input. This combustion air should be brought into the area containing the furnace below the level of the furnace burner.

Table 3
Combustion Air Opening Dimensions

Model No.	Combustion Air Opening Dimensions (2 required)
O25-80/105/120	10" X 20"
O25-140/154	11" X 22"

Unconfined Space

An unconfined space is an area such as a basement or large equipment room with a volume greater than 50 cubic feet (1.4 cubic meters) per 1,000 Btu (293 W) per hour of the combined input rating of all appliances installed in that space. This space also includes adjacent rooms which are not separated by a door. Though an area may appear to be unconfined, it might be necessary to bring in outdoor air for combustion if the structure does not provide enough air by infiltration. If the furnace is located in a building of tight construction with weather stripping and caulking around the windows and doors, follow the procedures outlined for using air from the outside for combustion and ventilation.

Confined Space

A confined space is an area with volume less than 50 cubic feet (1.4 cubic meters) per 1,000 Btu (293 W) per hour of the combined input rating of all appliances installed in that space. This definition includes furnace closets or small equipment rooms.

When the furnace is installed so that supply ducts carry air circulated by the furnace to areas outside the space containing the furnace, the return air must be handled by ducts which are sealed to the furnace casing and which terminate outside the space containing the furnace. This is especially important when the furnace is mounted on a platform in a confined space such as a closet or small equipment room. Even a small leak around the base of the unit at the platform or at the return air duct connection can cause a potentially dangerous negative pressure condition. Air for combustion and ventilation can be brought into the confined space either from inside the building or from outside.

Air from an Adjacent Space

If the confined space housing the furnace adjoins space categorized as unconfined, air can be brought in by providing two permanent openings between the two spaces. Each opening must have a minimum free area of 1 square inch (6.4 square centimeters) per 1,000 Btu (293 W) per hour of the total input rating of all fuel-fired equipment in the confined space. Each opening must be at least 100 square inches (614.5 square centimeters). One opening shall be within 12" (305 mm) of the top of the enclosure and one opening within 12" (305 mm) of the bottom (See figure 8).

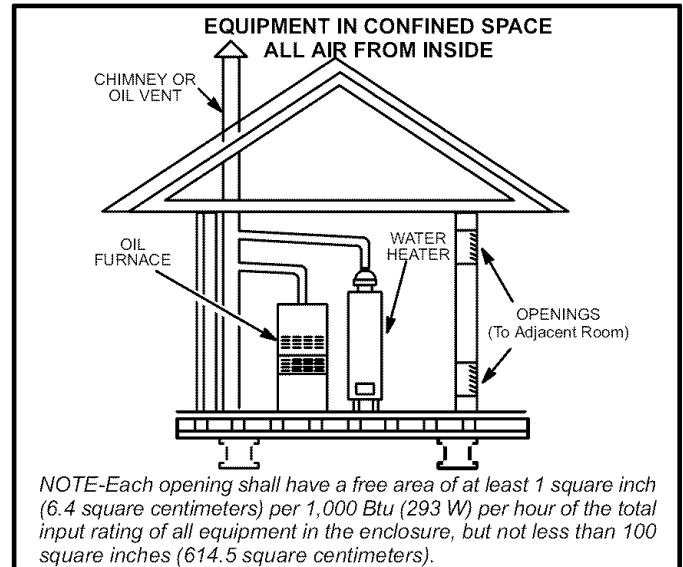

FIGURE 8

Air from Outside

If air from outside is brought in for combustion and ventilation, the confined space shall be provided with two permanent openings. One opening shall be within 12" (305 mm) of the top of the enclosure and one within 12" (305 mm) of the bottom. These openings must communicate directly or by ducts with the outdoors or spaces (crawl or attic) that freely communicate with the outdoors or indirectly through vertical ducts. Each opening shall have a minimum free area of 1 square inch (6.4 square centimeters) per 4,000 Btu (1172 W) per hour of total input rating of all equipment in the enclosure (See figures 9 and 11). When communicating with the outdoors through horizontal ducts, each opening shall have a minimum free area of 1 square inch (6.4 square centimeters) per 2,000 Btu (586 W) per total input rating of all equipment in the enclosure (See figure 11).

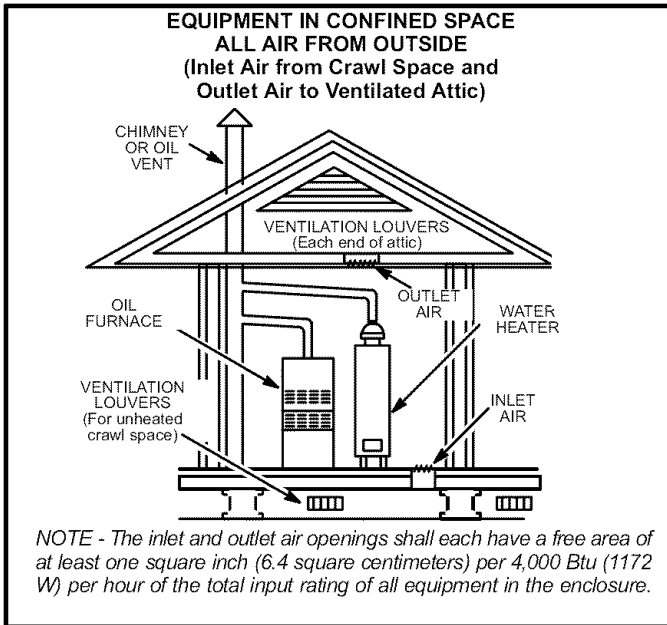

FIGURE 9

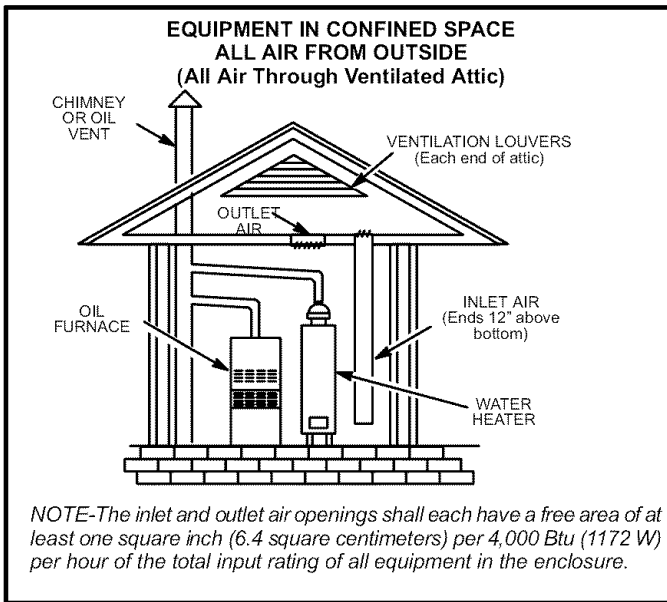

FIGURE 10

When ducts are used, they shall be of the same cross-sectional area as the free area of the openings to which they connect. The minimum dimension of rectangular air ducts shall be no less than 3" (76 mm). In calculating free area, the blocking effect of louvers, grilles, or screens must be considered. If the design and free area of protective covering is not known for calculating the size opening required, it may be assumed that wood louvers will have 20 to 25 percent free area and metal louvers and grilles will have 60 to 75 percent free area. Louvers and grilles must be fixed in the open position or interlocked with the equipment so that they are opened automatically during equipment operation.

A return air duct system is recommended. If a complete return air duct system is not installed, a full-sized return duct should be run to a location outside of the confined space. In either case, the return air duct must be completely sealed so that no air from the confined space can be circulated through the duct system.

A minimum mixed return air temperature of 60°F to 65° F must be maintained for outdoor make-up air in order to prevent condensation and corrosion.

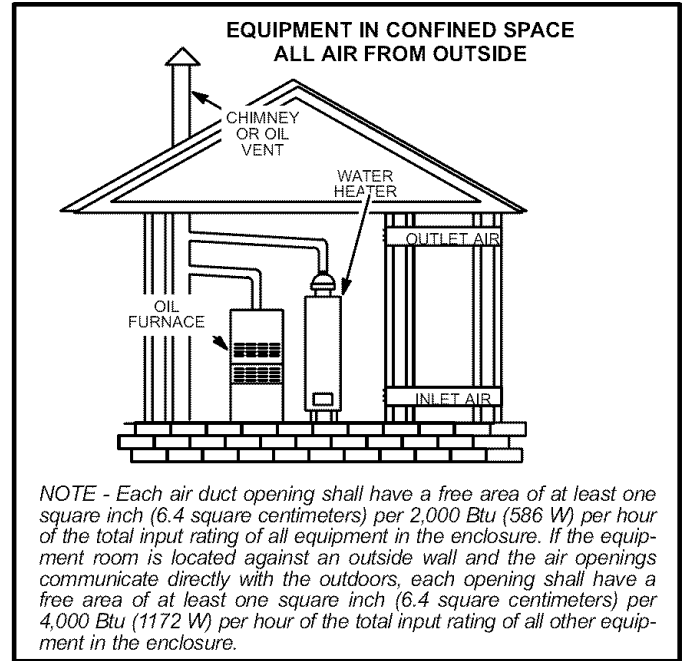

FIGURE 11

Venting

⚠ WARNING

Combustion air openings in front of the furnace must be kept free of obstructions. Any obstruction will cause improper burner operation and may result in a fire hazard.

⚠ WARNING

The barometric damper shall be in the same atmospheric pressure zone as the combustion air inlet to the furnace. Deviation from this practice will cause improper burner operation and may result in a fire hazard.

⚠ CAUTION

Do not store combustible materials near the furnace or supply air ducts. The material (such as paint, motor oil, gasoline, paint thinner, etc.) may ignite by spontaneous combustion creating a fire hazard.

! WARNING

This furnace is certified for use with type "L" vent. "B" vent must not be used with oil furnaces.

NOTE - Oil burning equipment may be vented into an approved masonry chimney or type L vent. (Type L vent is similar in construction to type B gas vent except it carries a higher temperature rating and is constructed with an inner liner of stainless steel rather than aluminum).

Prior to installation of unit, make a thorough inspection of the chimney to determine whether repairs are necessary. Make sure the chimney is properly constructed and sized according to the requirements of the National Fire Protection Association. The smallest dimensions of the chimney should be at least equal to the diameter of the furnace vent connector. Make sure the chimney will produce a steady draft sufficient to remove all the products of combustion from the furnace. A draft of at least .04" w.c. (9.9 Pa) is required during burner operation.

- 1 - Local building codes may have more stringent installation requirements and should be consulted before installation of unit.
- 2 - The vent connector should be as short as possible to do the job.
- 3 - The vent connector should not be smaller than the outlet diameter of the vent outlet of the furnace.
- 4 - Pipe should be at least 24 gauge galvanized.
- 5 - Single wall vent pipe should not run outside or through any unconditioned space.
- 6 - Chimney should extend 3 feet (0.9 m) above any flat section of roof within a horizontal distance of 10 feet (3 m). The chimney must also extend 2 feet (0.6 m) above the highest roof peak within a horizontal distance of 10 feet (3 m).
- 7 - The vent must not pass through a floor or ceiling. Clearances to single wall vent pipe should be no less than 6" (152 mm); more if local codes require it.
- 8 - The vent may pass through a wall where provisions have been made for a thimble as specified in the Standards of the National Board of Fire Underwriters. See figure 12.

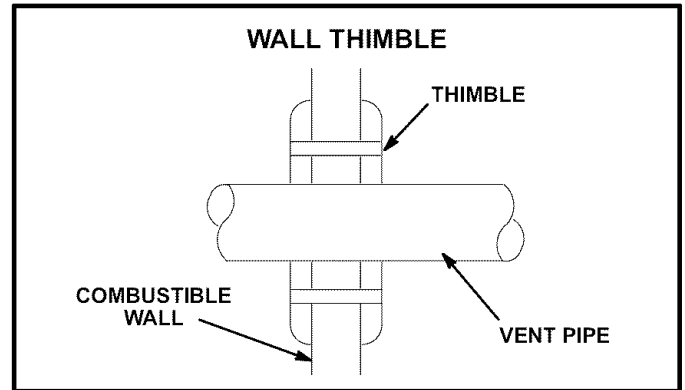

FIGURE 12

- 9 - The vent pipe should slope upward toward the chimney on horizontal run at least 1/4 inch (6 mm) to the foot (0.3 m) and should be supported by something other than the furnace, such as isolation hangers. See figure 14.
- 10- Extend the vent pipe into the chimney so that it is flush with the inside of the vent liner. Seal the joint between the pipe and the liner.
- 11- The furnace shall be connected to a factory built chimney or vent complying with a recognized standard, or masonry or concrete chimney lined with a lining material acceptable to the authority having jurisdiction.
- 12- When two or more appliances vent into a common vent, the area of the common vent should not be less than the area of the largest vent or vent connection plus 50% of the area of the additional vent or vent connection. Chimney must be able to sufficiently vent all appliances operating at the same time.
- 13- The vent pipe shall not be connected to a chimney vent serving a solid fuel appliance or any mechanical draft system.
- 14- All unused chimney openings should be closed.
- 15- All vent pipe run through unconditioned areas or outside shall be constructed of factory built chimney sections. See figure 13.
- 16- Where condensation of vent gas is apparent, the vent should be repaired or replaced. Accumulation of condensation in the vent is unacceptable.
- 17- Vent connectors serving this appliance shall not be connected into any portion of mechanical draft systems operating under positive pressure.
- 18- Keep the area around the vent terminal free of snow, ice and debris.

NOTE - If vent pipe needs to exit from side of cabinet, use the pilot hole (located on either side of the unit) to cut a 6" (152 mm) round hole. Attach finishing plate (provided) with four sheet metal screws to cover rough edges.

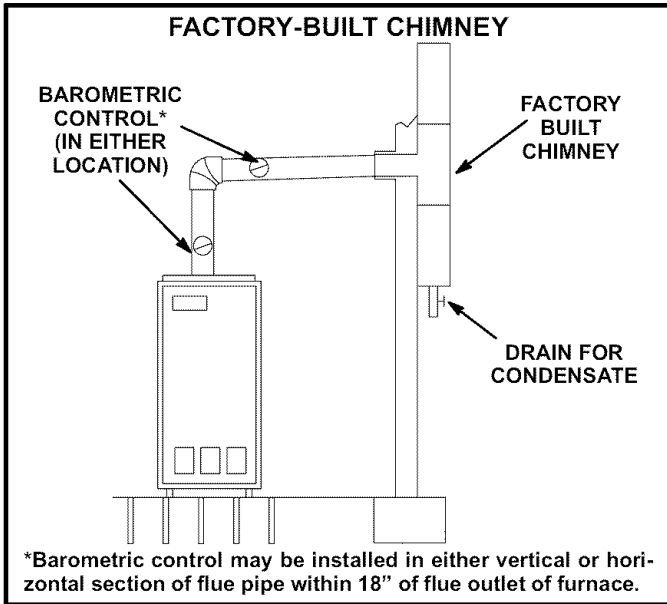

Figure 13

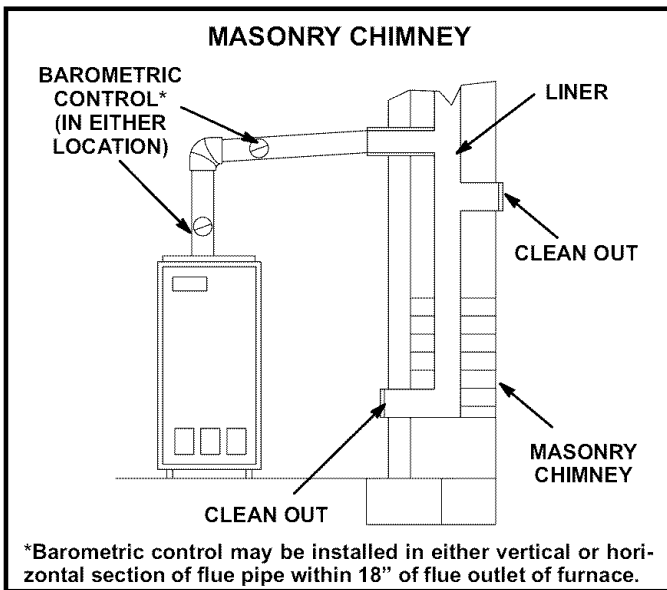

Figure 14

Horizontal Venting

The O25 is approved for horizontal venting with the following mechanical vent systems:

Tjernlund (sideshot) #SS1C (Cat. #35E08) or Field Controls #SWG-5 (Cat. #35P08) with the CK-61 (Cat. #18N28) control kit. Refer to the manufacturers' installation instructions for proper installation procedures and service parts information.

Do not use the same vent with any other appliance when using a sidewall vent system.

Maximum permissible vent length is 100 equivalent feet. Minimum length is 15 equivalent feet. Calculate the equivalent vent pipe footage from the furnace to the mechanical vent system (Tjernlund or Field Controls) by adding the straight vent pipe length and the equivalent elbow lengths together. Each 90° elbow is equivalent to 10 feet of straight pipe. Each 45° elbow is equal to 5 feet of straight pipe.

Locate the barometric draft control within 18 inches of the furnace flue outlet. See figure 15 for barometric draft control location.

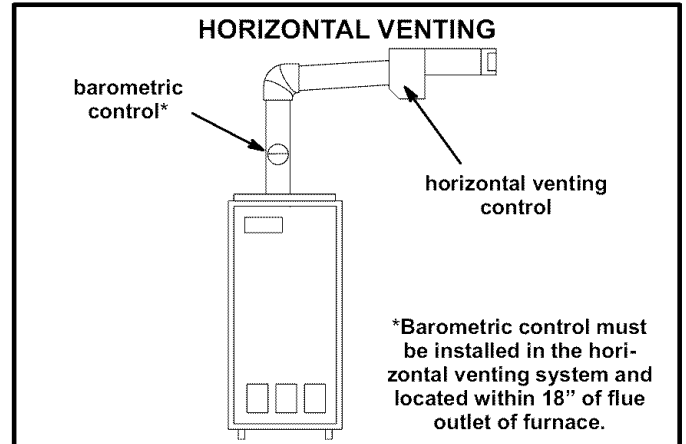

Figure 15

Vent Connector (Smoke Pipe) and Draft Control

⚠ IMPORTANT

When smoke pipe is installed at less than minimum clearance listed in table 2, radiation shields must be installed. See figure 16.

Use 24 gauge or heavier galvanized smoke pipe and fittings to connect the furnace to the vent. Connect the vent connector (smoke pipe) to the chimney using the least number of elbows and angles possible. Flue pipe or vent connector must be inserted into but not beyond the outside wall of the chimney flue. No reduction in diameter of pipe is acceptable. It is best to have the smoke pipe as short and direct as possible. Where two or more appliances vent into a common flue, the area of the common flue should be at least equal to the area of the largest flue or vent connector, plus 50% of the area of any additional flues or vent connectors. Install a barometric draft control (provided) and flue pipe according to instructions packed with control.

Inspect flue pipe annually. Clean soot or ash from flue pipe, if necessary. If pipe is rusted, replace.

Install draft control at least 12 inches beyond the furnace. If there is no space to install the draft control in the flue pipe it may be installed in the vent above the flue pipe. Follow the instructions packed with the draft control.

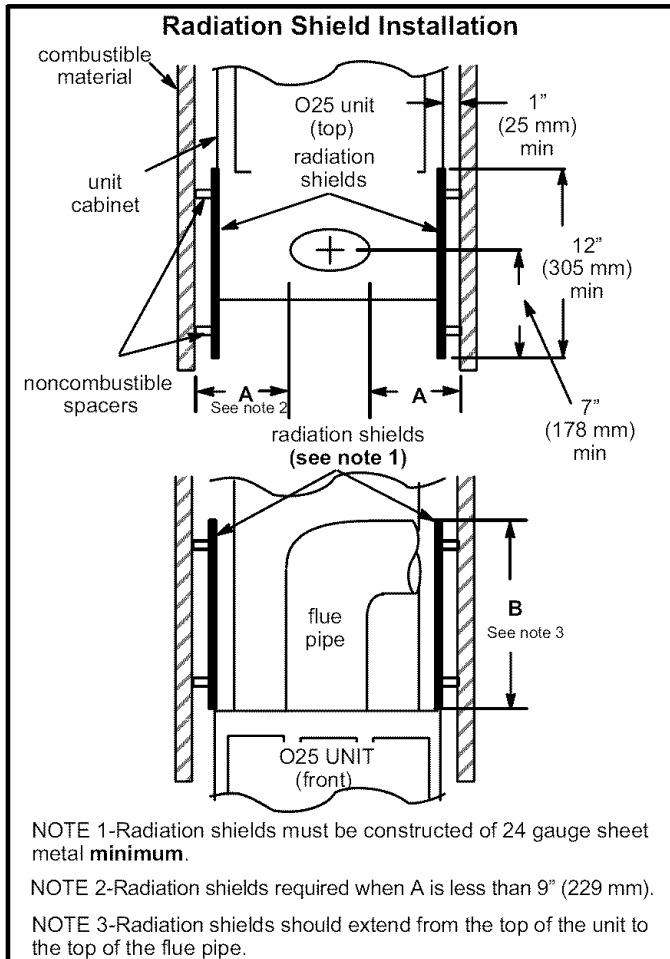

Figure 16

Removal of Unit from Common Venting System

In the event that an existing furnace is removed from a venting system commonly run with separate appliances, the venting system is likely to be too large to properly vent the remaining attached appliances. The following test should be conducted while each appliance is in operation and the other appliances not in operation remain connected to the common venting system. If venting system has been installed improperly, the system must be corrected as outlined in the previous section.

- 1 - Seal any unused openings in the common venting system.
- 2 - Visually inspect venting system for proper size and horizontal pitch and determine there is no blockage or restriction, leakage, corrosion or other deficiencies which could cause an unsafe condition.
- 3 - Insofar as is practical, close all building doors and windows and all doors between the space in which the appliances remaining connected to the common venting system are located and other spaces of the building. Turn on clothes dryers and any appliances not con-

nected to the common venting system. Turn on any exhaust fans, such as range hoods and bathroom exhausts, so they will operate at maximum speed. Do not operate a summer exhaust fan. Close fireplace dampers.

- 4 - Following the lighting instruction on the unit, place the appliance being inspected in operation. Adjust thermostat so appliance will operate continuously.
- 5 - Test for spillage using a draft gauge.
- 6 - After it has been determined that each appliance remaining connected to the common venting system properly vents when tested as outlined above, return doors, windows, exhaust fans, fireplace dampers and any other fuel burning appliance to their previous condition of use.
- 7- If improper venting is observed during any of the above tests, the common venting system must be corrected.

Supply & Return Air Plenums

Secure return air plenum to unit using sheet metal screws. *NOTE - The following are suggested procedures that should be followed when installing the supply air plenum.*

- 1 - Use fiberglass sealing strips to seal the plenum.
- 2 - In all cases, the plenum should be secured to furnace or evaporator cabinet using sheet metal screws.
- 3 - Supply and return air ducts must be the same dimension as the furnace opening. They must each be a minimum of 18" long.
- 4 - Install supply and return air ducts as desired.

Oil Supply Piping

Use continuous lengths of heavy wall copper tubing or steel pipe for oil supply pipe. Install oil supply pipe under floor or near walls to protect it from damage. Avoid running pipes along joists or reverberating surfaces. Always use flare fittings. All fittings must be accessible. Do not use compression fittings.

Manual bleeding of the fuel pump is required on initial start up. Failure to bleed air from the oil pump could result in an air lock/oil starvation condition.

NOTE - As an extra precaution, cycle heating on and off ten times after bleeding air from the oil pump. This will eliminate air in the gun assembly.

⚠ WARNING

Do not use pipe dope or Teflon tape on any direct oil connection to the fuel pump.

⚠ WARNING

The operating vacuum should not exceed 11.44 inches of mercury.

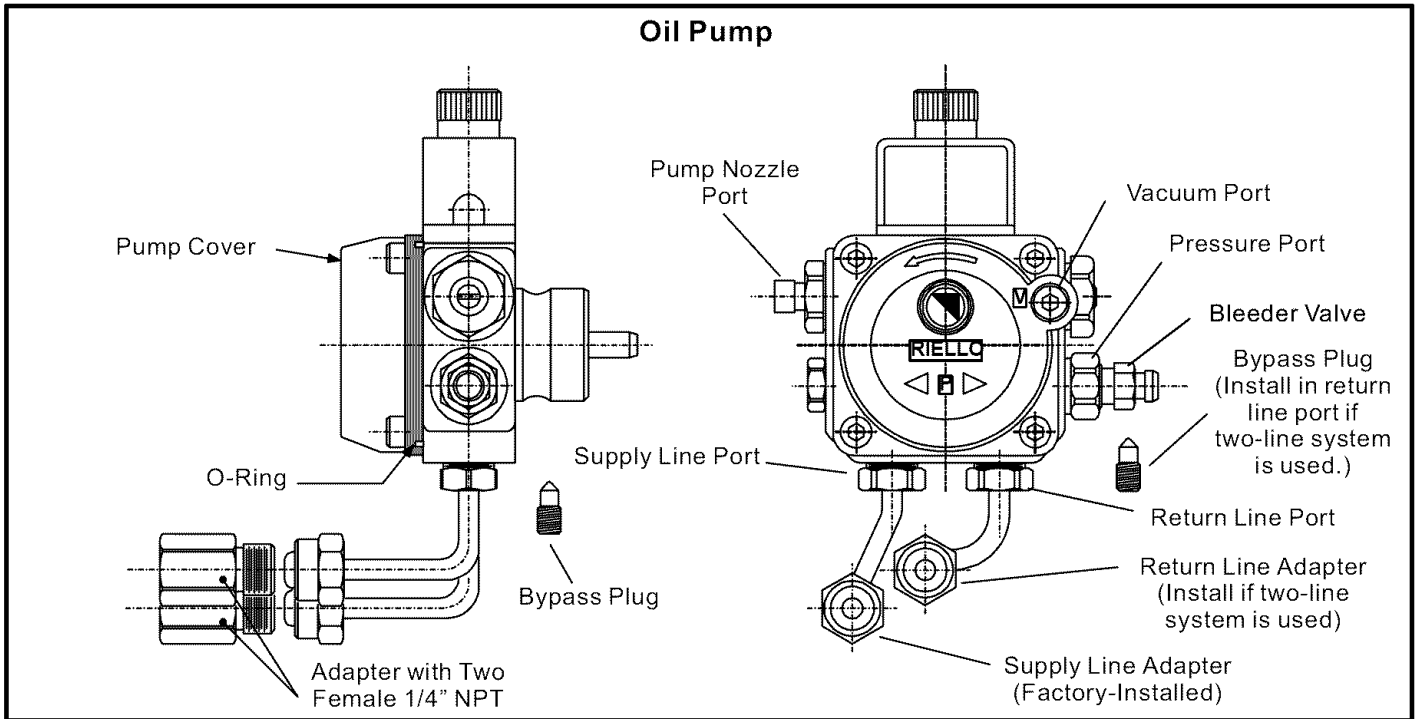

Figure 17

Oil Filter

An oil filter is required. Install the filter inside the building between the tank shut-off valve and the burner. Locate the filter close to the burner for easy maintenance; however, filter should be at least 3 feet away from the burner to avoid pressure drop problems. Table 4 lists the filters for the O25 furnace.

Table 4

Oil Filters	Cat. Number
10 micron filter (no mounting bracket)	81P89
10 micron filter (mounting bracket)	53P92
10 micron replacement cartridge for filter, 45 gph	53P93
Filter restriction indicator gauge	53P90

Piping System

The O25 unit is shipped with the oil pump set to operate in a single-line system. Ensure that the restrictions of the piping system, plus any lift involved, do not exceed the capability of the oil pump. Use the following guidelines when determining whether to use a single-or two-stage oil pump.

NOTE - Two pipe connectors are supplied with the unit. In addition, two adapters, each with two 1/4" NPT are provided to adapt oil lines to burner pipe connectors. All pump port threads are British parallel thread design. Direct connection of NPT threads to the pump will damage

the pump body. Riello manometers and vacuum gauges do not require adapters to be safely connected to the pump ports. A metric NPT adapter must be used when other gauges are used.

Single-Pipe Systems

⚠ CAUTION

Do not install the bypass plug into the pump pressure port on single-line systems. Operation of a single-line system with the bypass plug in place will result in damage to the pump shaft seal.

- 1 - Size the oil piping in a single-pipe system per table 5 and figure 18.
- 2 - Connect the properly sized pipe to the factory-installed adapter on the pump supply port.
- 3 - Check the plug in the return port to make sure that it is tightened securely.

Table 5
Single-Pipe Sizing

Height (H)	Maximum Length 3/8" OD Tubing	Maximum Length 1/2" OD Tubing
1.5'	33	65
3'	65	130
5'	130	260
6.5'	195	325

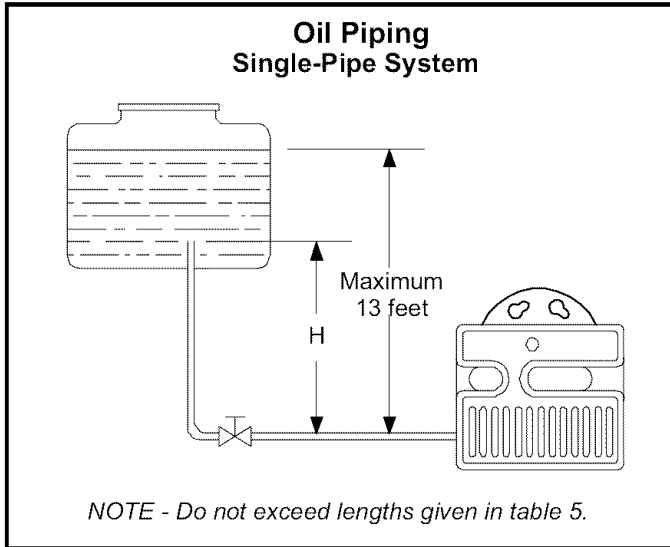

Figure 18

Two-Pipe Systems

- 1 - Use the provided 2.5mm hexagonal key to install the provided bypass plug in the pump return port.

NOTE - Use of an improperly sized, non-metric key may result in damage to the bypass plug.

- 2 - Install the provided NPT adapter on the pump return port
- 3 - Use table 6 and figure 19 to properly size the supply and return line piping.
- 4 - Connect the properly sized pipe to the adapters on the pump supply and return ports.

NOTE - Supply and return piping must be the same diameter and should extend to the same depth inside the fuel tank.

Table 6
Two-Pipe Sizing

Height (H)	Maximum Length 3/8" OD Tubing	Maximum Length 1/2" OD Tubing
0'	115	330
1.5'	100	330
3'	80	330
5'	65	295
6.5'	50	230
9.5'	25	100
11'	20	65

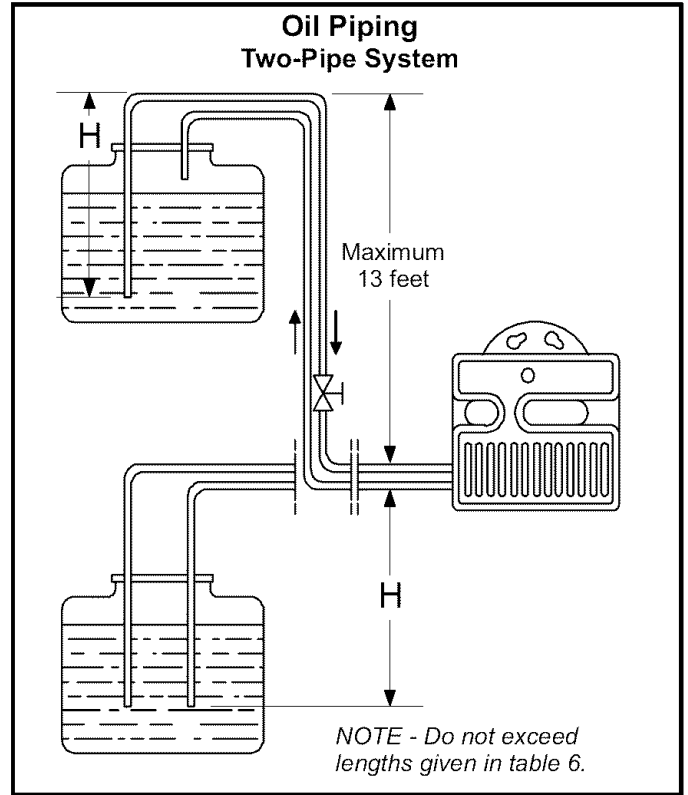

Figure 19

⚠ IMPORTANT

Both oil supply and return pipes must be submerged in oil in the supply tank.

Leak Check

After oil piping is completed, carefully check all piping connections (factory and field) for oil leaks.

Electrical Wiring

All wiring must conform to the National Electric Code (NEC), or Canadian Electric Code (CEC) and any local codes. Refer to figure 20 for low voltage and high voltage wiring connections.

- 1- Refer to the appliance rating plate for proper fuse size.
- 2- Install the room thermostat and make wire connections to the unit. Avoid installing thermostat on an outside wall or where it can be affected by radiant heat. Set the

adjustable heat anticipator on thermostat according to the wiring diagram sticker provided on unit.

- 3- Install a separate fused disconnect switch near unit so power can be shut off for servicing.
- 4- Complete line voltage wiring from disconnect switch near unit to make-up box.

NOTE - An equipment ground screw is provided. Refer to unit wiring diagram in figure 20. Ground unit using a suitable ground wire.

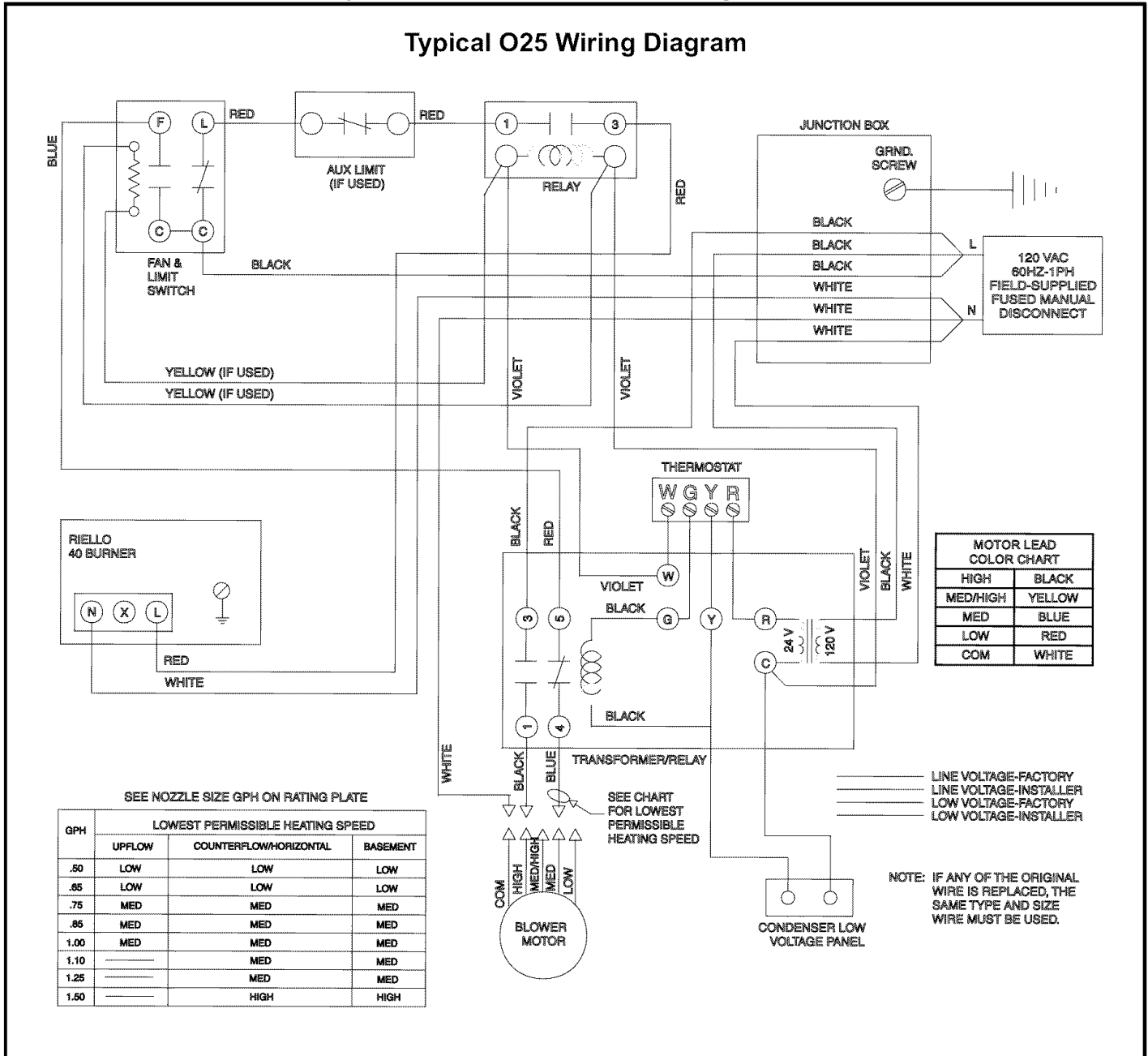

Figure 20

Pump Purging

Before starting unit, make sure the oil tank is adequately filled with clean No. 2 furnace oil.

NOTE - Water, rust or other contaminants in oil supply system will cause malfunction and failure of the internal parts of the fuel pump.

Single-Pipe Systems

- 1 - Loosen the pump bleeder valve until oil flows out.
NOTE - If no oil comes out of the loosened bleeder port, re-tighten the bleeder valve securely and add oil through the vacuum port. Use 4mm hex key to remove vacuum port plug.
- 2 - Disconnect nozzle oil supply line at the pump nozzle port.
- 3 - Attach one end of a flexible plastic tube to the pump nozzle port. Direct the other end of the flexible tube into a bucket and allow the oil to flow into the bucket.
- 4 - Loosen the screw(s) which secure the air tube cover.
- 5 - Hold the air tube cover in its proper position and start the burner.
- 6 - Allow the solenoid valve to engage (approximately 10 seconds after burner fires). Remove the air tube cover and shine a light source on the photo-cell. The cell must sense light.
- 7 - Run the burner until the fuel pump has been purged of air, then tighten the bleeder valve and immediately shut down the burner.
- 8 - Reinstall the air tube cover and nozzle line.
- 9 - Start the burner normally.

WARNING

If steps 2 or 3 are omitted, unburned oil will collect in the combustion chamber. This will create a hazardous condition during burner start-up.

Two-Pipe Systems

- 1 - Turn off main power source to the burner and remove the air tube cover.
- 2 - Shine a light source on the photo-cell. As long as the light source remains on the photo-cell, the solenoid valve will not open and the burner will continue to operate in pre-purge mode only.
- 3 - Return power to the burner and fire the burner.
NOTE - Burner will operate in pre-purge only as long as the light source shines on the photo-cell.
- 4 - Run the burner until the fuel pump has been purged of air.
- 5 - Replace air tube cover.
- 6 - Restore power to the burner and start the burner normally.

Unit Start-Up & Adjustments

CAUTION

Never burn garbage or paper in the heating system. Never leave papers near or around the unit.

CAUTION

Blower door and all burner covers must be in place before start-up.

WARNING

Do not start the burner if excess oil has accumulated in the chamber, if the furnace is full of vapor, or if the combustion chamber is very hot. Such actions could result in property damage, personal injury, or death.

- 1 - Set thermostat for heating demand and turn on electrical supply to unit.
- 2 - If burner fails to start, push reset button on primary safety control and the burner motor reset button on the front of the burner.

CAUTION

Do not push the reset button on the primary control more than one time.

- 3 - If the burner fails to light again, refer to the troubleshooting section in this manual.

Fuel Pump Pressure

Use 11mm wrench to remove bleeder port cover. Attach Riello gauge (or use adapter to attach NPT gauge) to bleeder port. Turn unit on and measure fuel pump pressure. Check pressure and compare to table 1. Adjust if necessary.

Vacuum Pressure

Use 4mm hex key to remove vacuum port cover. Attach Riello gauge (or use adapter to attach NPT gauge) to bleeder port. Start burner and measure operating vacuum. Operating vacuum should not exceed 11.44 inches w.c. Correct, if necessary.

Temperature Rise

To measure temperature rise, place plenum thermometers in warm air and return air plenums. Locate thermometer in warm air plenum where thermometer will not "see" the heat exchanger to prevent it from picking up radiant heat. Set thermostat to its highest setting to start unit. After plenum thermometers have reached their highest and steadiest readings, subtract the readings. The difference in temperatures in the supply and return air plenums should approximate the temperature rise range listed on the unit rating plate. If not, adjust the blower motor pulley to adjust the blower speed.

Fan and Limit Control

The fan and limit control is factory installed and wired.

Burner Adjustment

WARNING

Service must be performed by a qualified installer or service agency.

The following instructions are essential to the proper operation of O25 series oil furnaces. Refer to table 1 for nozzle and pump pressure information. The proper way to adjust an oil burner is with a CO₂ analyzer and a smoke gun. A properly adjusted burner will result in a quiet, clean fire which will prevent sooting and frequent cleaning. To establish tolerance or a "window of operation" into the unit, do not exceed #0 smoke. This will give the burner more flexibility when there are changes in the surrounding environment.

- 1 - Punch a 5/16" diameter service hole in the flue outlet. This sampling hole should be at least two flue diameters above the breeching, or elbow at the breeching but ahead of the barometric damper.
- 2 - Place burner into operation. Adjust air setting for good flame by visual observation, and run for at least 10 minutes or until operation has stabilized. A good flame will be entirely contained in the combustion chamber and will be predominantly yellow-white in color. As flame quality lessens, the flame will turn more orange in color and will start to rise above the combustion chamber.
- 3 - Take a draft reading at the service hole. Adjust barometric draft control in the stack to achieve an overfire draft of 0" to -.01" and a breach of -.02" to -.04".
- 4 - Use an industry standard smoke tester to take and record a smoke reading at the service hole. If smoke is evident, it could be caused by a poor nozzle or combustion setting. In some cases, it may be caused by a difference in oil or an unusual condition of installation.
- 5 - If the burner is producing more than #0 smoke, loosen the air adjustment plate screw and rotate the air adjustment plate until the flame appears clean. Take care to re-tighten air adjustment plate screw when adjustments are complete. It may also be necessary to adjust the turbulator settings slightly (toward a higher number) in order to reduce smoke.
- 6 - Reset the draft if combustion head or air settings were adjusted.
- 7 - Use a suitable emissions test instrument to take and record a reading at the service hole. The CO₂ measured in the stack should be in the 11 to 12 percent range.
- 8 - Use a suitable thermometer to obtain and record the flue gas temperature at the service hole.
- 9 - If necessary, adjust the air plate to achieve the desired operating range.
- 10 - When the proper combustion and smoke readings have been achieved, tighten the air adjustment plate screw.
- 11 - Re-secure the burner cover and re-check the draft, smoke, combustion and flue gas temperature.

Service

CAUTION

Do not tamper with unit controls. Call your qualified service technician.

Filter

NOTE - Under no circumstances should the access panels to the blower compartment be left off or left partially open. Check filters monthly and replace when necessary to assure proper furnace operation. Replace filters with like kind and size filters.

Blower

Blower motor is prelubricated and sealed for extended operation. No further lubrication is required. Blower assembly may be removed from cabinet to clean. Disconnect power to unit before checking blower wheel for debris.

Flue Pipe

The flue pipe should be inspected annually by a qualified service technician. Remove and clean any soot or ash found in the flue pipe. Inspect pipe for holes or rusted areas. If replacement is necessary, replace with the same size and type as required by code. Inspect the flue draft control device and replace if found defective.

Burner

Check the nozzle and oil filter before each heating season. Also check the items listed in the oil furnace start-up checklist on page 18. **The oil supply line shut-off valve should be closed when the unit is shut down over an extended period of time.**

Cleaning the Heat Exchanger

- 1 - Remove the vent pipe from the furnace.
- 2 - Loosen the clean-out cap screw, rotate the clean-out cap to the notch and remove the cap. Remove flue access elbow.
- 3 - Use a long spiral wire brush to sweep down the outer drum of the heat exchanger. Use the hose attachment to vacuum loose debris.
- 4 - Loosen the observation port cap screw, rotate the cap to the notch and remove the cap. Use a spiral wire brush to reach up toward the rear of the heat exchanger to clean the crossover tube. Replace the cap and screw on the observation port.

CAUTION

Do not attempt to clean the combustion chamber. It can be easily damaged.

- 5 - Replace the three clean out caps and flue access elbow. Make sure locking screws are secure.
- 6 - Brush out and vacuum the vent outlet area of the outer drum and replace vent pipe.
- 7 - Clean the burner, blower deck and vestibule area.

NOTE - A heat exchanger brush ABRSH380 (35K09) is available from Lennox.

O25 Start-Up & Performance Check List

OIL FURNACE START-UP CHECKLIST
(Complete this page and keep for future reference)

Customer Name _____

Address _____

Furnace Model # _____ Serial # _____

Input Rate _____ Nozzle Used _____

New Construction _____ Replacement _____

Date of Installation _____

Start-Up Procedure

- A. Close disconnect switch _____
- B. Set thermostat to call for heat _____
- C. Bleed air from lines and pump; run for 20 seconds after bubbles disappear _____.
- D. Install vacuum gauge; check pump vacuum _____
- E. Install pressure gauge; adjust pressure to 140 psig (except on Q2-80 models – adjust to 100 psig) _____
Always verify proper pump pressure to corresponding tables with instructions supplied with unit.
- F. After 10 minutes of operation, obtain flue temperature reading: 1st _____ 2nd _____ 3rd _____
- G. Obtain smoke reading:
1st _____ 2nd _____ 3rd _____
- H. Measure CO₂: 1st _____ 2nd _____ 3rd _____
- I. Check draft overfire _____ Breech _____
- J. Air shutter setting _____ Locked _____
- K. Measure static pressure in duct system
Static pressure on supply side _____
Static pressure on return side _____
Static pressure drop _____
- L. Temperature rise after steady state conditions have been achieved: Supply side _____ Return side _____
- M. Block off return air (limit control checkout); burner should shut down in 2 or 3 minutes _____

Owner Record

Installed By: _____

Dealer _____

Address _____

Telephone # _____

License # _____