

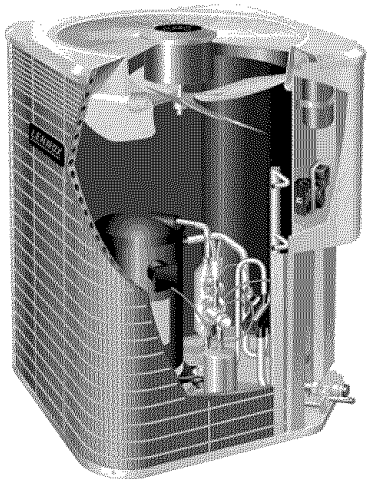

©2002 Lennox Industries Inc.
Dallas, Texas



INSTALLATION INSTRUCTIONS

HPXA12 SERIES UNITS

HEAT PUMP UNITS
504,777M
05/04
Supersedes 02/04

TP Technical
Publications
Litho U.S.A.

Table of Contents

HPXA12 Outdoor Unit	1
Shipping & Packing List	1
General Information	1
Unit Dimensions	2
Setting the Unit	3
Electrical	4
Refrigerant Piping	5
Flushing Existing Line Set & Indoor Coil	6
Refrigerant Metering Device	7
Manifold Gauge Set	8
Service Valves	8
Leak Testing	9
Evacuation	10
Start-Up	11
Charging	11
System Operation	14
Defrost System	15
Maintenance	18
Optional Accessories	18
Homeowner Information	18
HPXA12 Check List	20

**RETAIN THESE INSTRUCTIONS
FOR FUTURE REFERENCE**

HPXA12 Outdoor Unit

HPXA12 Elite® outdoor units use R410A, which is an ozone friendly HFC refrigerant. This unit must be installed with a matching indoor blower coil and line set as outlined in the Lennox Engineering Handbook. HPXA12 outdoor units are designed for use in expansion valve systems only. They are not designed to be used with other refrigerant flow control devices. An expansion valve approved for use with R410A must be ordered separately and must be installed prior to operating the unit.

⚠ IMPORTANT

This unit must be matched with an indoor coil as specified in Lennox' Engineering Handbook. Coils previously charged with R22 must be flushed

Shipping & Packing List

1 - Assembled HPXA12 outdoor unit
Check the unit components for shipping damage. If you find any damage, immediately contact the last carrier.

⚠ IMPORTANT

The Clean Air Act of 1990 bans the intentional venting of refrigerant (CFC's, HFC's, and HCFC's) as of July 1, 1992. Approved methods of recovery, recycling or reclaiming must be followed. Fines and/or incarceration may be levied for noncompliance.

⚠ WARNING

Improper installation, adjustment, alteration, service or maintenance can cause property damage, personal injury or loss of life. Installation and service must be performed by a qualified installer or service agency.

General Information

These instructions are intended as a general guide and do not supersede local codes in any way. Consult authorities having jurisdiction before installation.

⚠ WARNING

This product and/or the indoor unit it is matched with may contain fiberglass wool.

Disturbing the insulation during installation, maintenance, or repair will expose you to fiberglass wool dust. Breathing this may cause lung cancer. (Fiberglass wool is known to the State of California to cause cancer.)

Fiberglass wool may also cause respiratory, skin, and eye irritation.

To reduce exposure to this substance or for further information, consult material safety data sheets available from address shown below, or contact your supervisor.

**Lennox Industries Inc.
P.O. Box 799900
Dallas, TX 75379-9900**



Unit Dimensions - inches (mm)

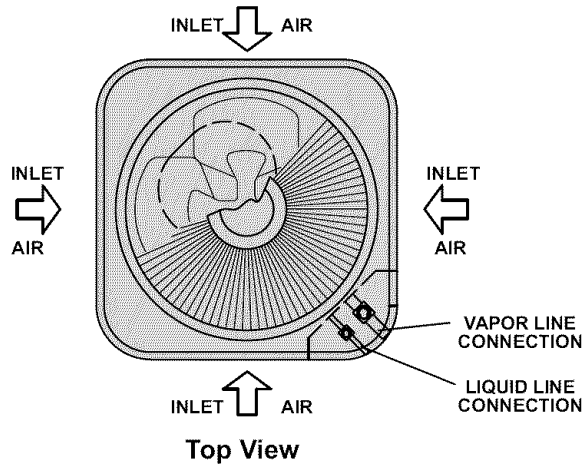

Model No.		A	B	C
HPXA12-018	in.	24-1/4	33-1/4	32-1/2
HPXA12-024				
HPXA12-030	mm	616	845	826
HPXA12-036				
HPXA12-042				
HPXA12-048	in.	28-1/4	37-1/4	36-1/2
HPXA12-060	mm	718	946	927

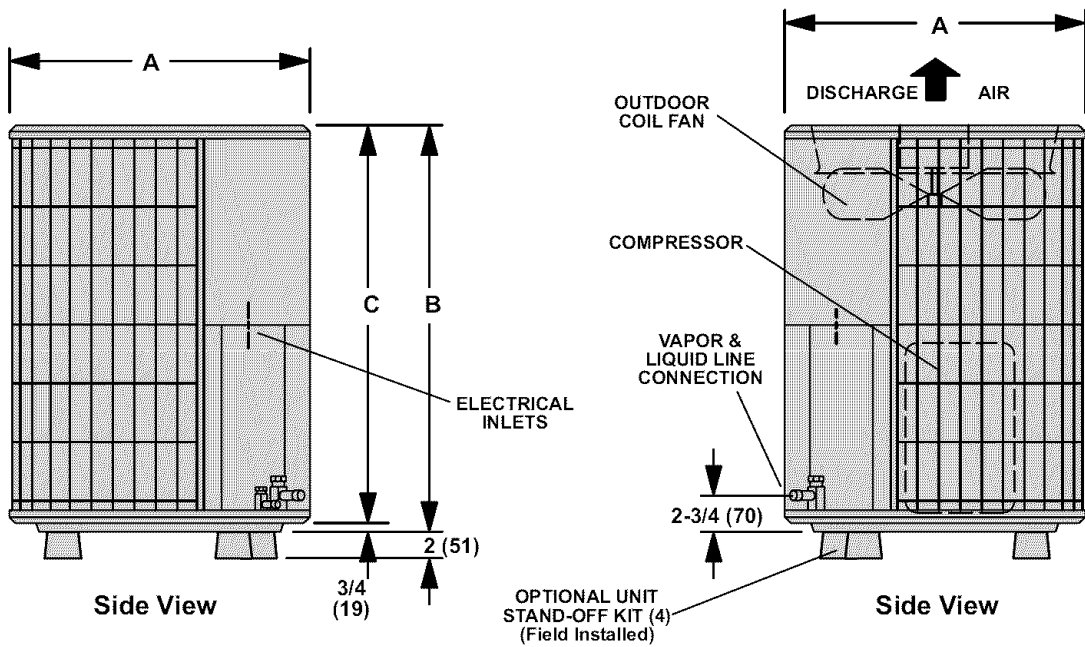

Setting the Unit

⚠ CAUTION

In order to avoid injury, take proper precaution when lifting heavy objects.

⚠ CAUTION

Sharp sheet metal edges can cause injury. When installing the unit, avoid accidental contact with sharp edges.

Outdoor units operate under a wide range of weather conditions; therefore, several factors must be considered when positioning the outdoor unit. Unit must be positioned to give adequate clearances for sufficient airflow and servicing. A minimum clearance of 24 inches (610 mm) between multiple units must be maintained. Refer to figure 1 for installation clearances.

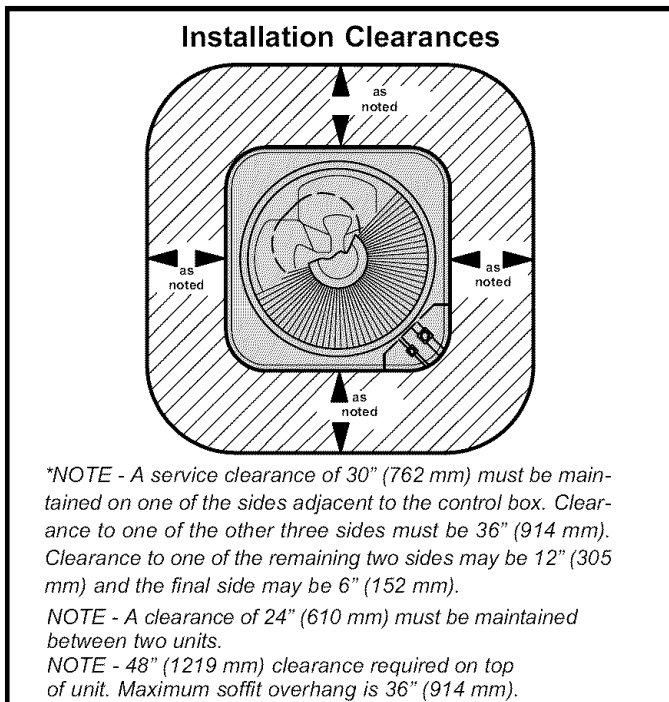

Figure 1

- 1 - Place a sound-absorbing material, such as Isomode, under the unit if it will be installed in a location or position that will transmit sound or vibration to the living area or adjacent buildings.
- 2 - Mount unit high enough above ground or roof to allow adequate drainage of defrost water and prevent ice build-up.
- 3 - In heavy snow areas, do not locate unit where drifting will occur. The unit base should be elevated above the depth of average snows.

NOTE - Elevation of the unit may be accomplished by constructing a frame using suitable materials. If a support frame is constructed, it must not block drain holes in unit base.

- 4 - When installed in areas where low ambient temperatures exist, locate unit so winter prevailing winds do not blow directly into outdoor coil.
- 5 - Locate unit away from overhanging roof lines which would allow water or ice to drop on, or in front of, coil or into unit.

Slab Mounting-Figure 2

When installing the unit at grade level, the top of the slab should be high enough above the grade so that water from higher ground will not collect around the unit. See figure 2. The slab should have a slope tolerance away from the building of 2 degrees or 2 inches per 5 feet (51 mm per 1524 mm). This will prevent ice build-up under the unit during a defrost cycle. Refer to roof mounting section for barrier construction if the unit must face prevailing winter winds.

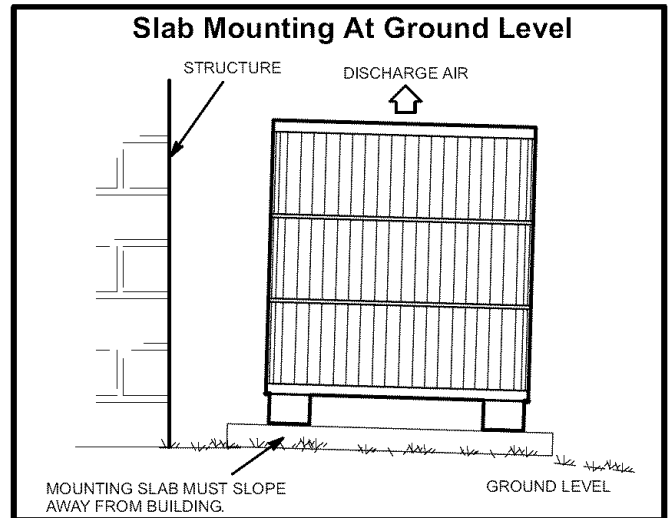

Roof Mounting-Figure 3

Install unit a minimum of 6 inches (152 mm) above the roof surface to avoid ice build-up around the unit. Locate the unit above a load bearing wall or area of the roof that can adequately support the unit. Consult local codes for rooftop applications.

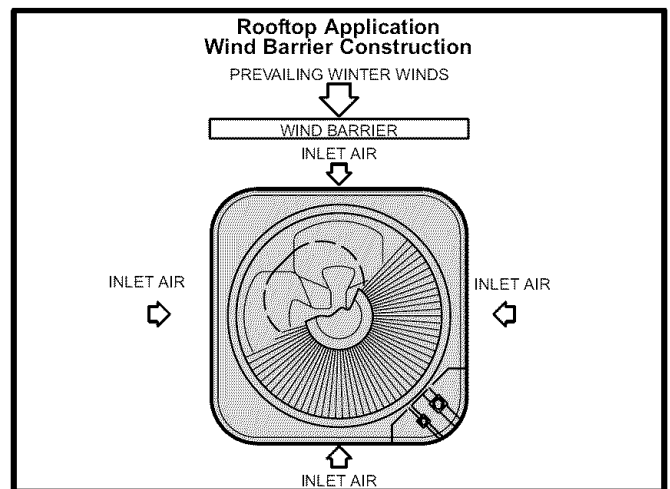

If unit coil cannot be mounted away from prevailing winter winds, construct a wind barrier. Size barrier at least the same height and width as the outdoor unit. Mount barrier 24 inches (610 mm) from the sides of the unit in the direction of prevailing winds.

Electrical

In the U.S.A., wiring must conform with current local codes and the current National Electric Code (NEC). In Canada, wiring must conform with current local codes and the current Canadian Electrical Code (CEC).

Refer to the furnace or blower coil installation instructions for additional wiring application diagrams and refer to unit nameplate for minimum circuit ampacity and maximum overcurrent protection size.

⚠ WARNING

Unit must be grounded in accordance with national and local codes. Electric Shock Hazard. Can cause injury or death.

- 1 - Install line voltage power supply to unit from a properly sized disconnect switch.
- 2 - Ground unit at unit disconnect switch or to an earth ground.

NOTE - To facilitate conduit, a hole is in the bottom of the control box. Connect conduit to the control box using a proper conduit fitting.

NOTE - Units are approved for use only with copper conductors.

Refer to figure 4 for high voltage field wiring diagram.

NOTE - A complete unit wiring diagram is located inside the unit control box cover.

- 3 - Install room thermostat (ordered separately) on an inside wall approximately in the center of the conditioned area and 5 feet (1.5 m) from the floor. It should not be installed on an outside wall or where it can be effected by sunlight, drafts or vibrations.
- 4 - Install low voltage wiring from outdoor to indoor unit and from thermostat to indoor unit. See figures 5 and 6. *NOTE - 24V, Class II circuit connections are made in the low voltage junction box.*

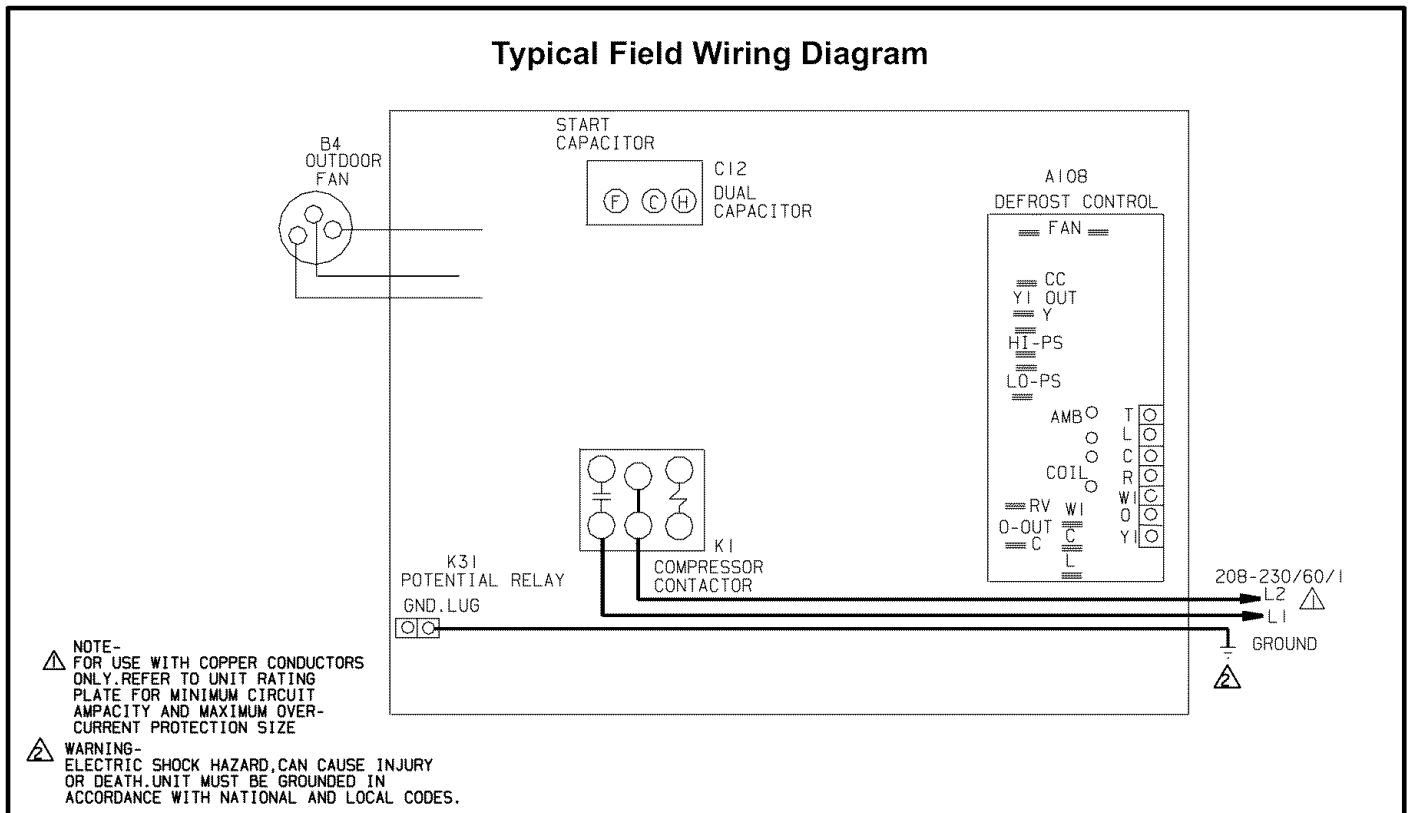

Figure 4

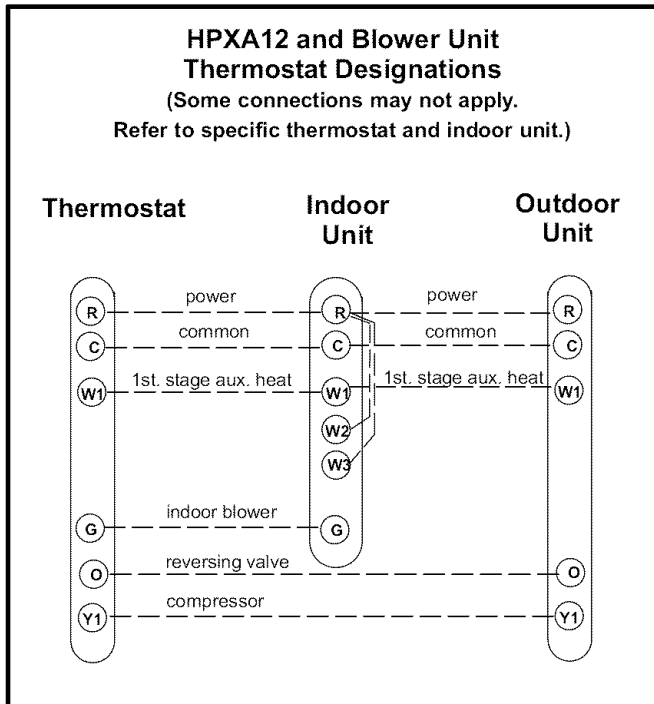

Figure 5

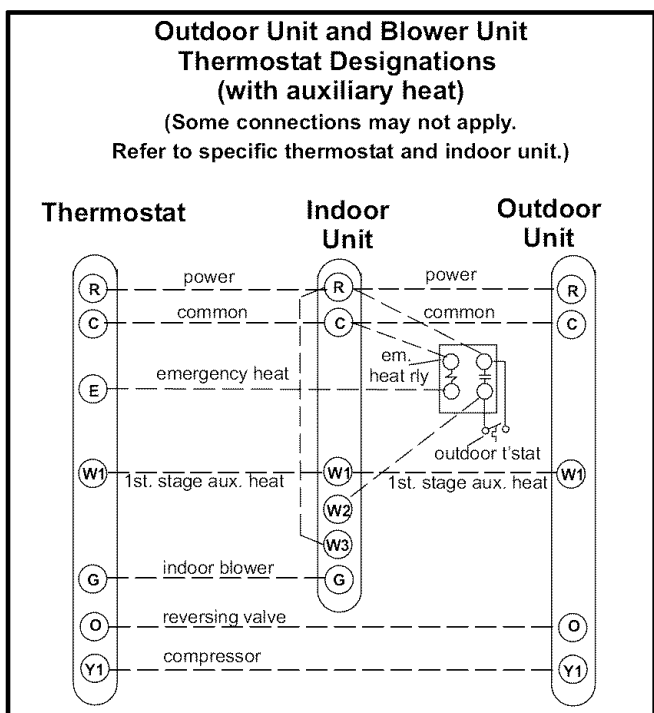

Figure 6

Refrigerant Piping

If the HPXA12 unit is being installed with a new indoor coil and line set, the plumbing connections should be made as outlined in this section. If an existing line set and/or indoor coil is going to be used to complete the HPXA12 system, refer to the following section that includes flushing procedures.

Field refrigerant piping consists of liquid and vapor lines from the outdoor unit (sweat connections) to the indoor coil (flare or sweat connections). Use Lennox L15 (sweat, non-flare) series line sets as shown in table 1 or use field-fabricated refrigerant lines. Refer to Refrigerant Piping Guide (Corp. 9351-L9) for proper size, type, and application of field-fabricated lines. Valve sizes are also listed in table 1.

Plumbing Connections

HPXA12 Matched with New Indoor Coil and Line Set

If you are replacing an existing coil that is equipped with a liquid line functioning as a metering orifice, replace the liquid line prior to installing the HPXA12 unit. See table 1.

**Table 1
Refrigerant Line Sets**

Model	Valve Field Size Connections		Recommended Line Set		
	Liquid Line	Vapor Line	Liquid Line	Vapor Line	L15 Line Sets
-18 -24 -30	3/8 in. (10 mm)	3/4 in. (19 mm)	3/8 in. (10 mm)	3/4 in. (19 mm)	L15-41 15 ft. - 50 ft. (4.6 m - 15 m)
-36 -42 -48	3/8 in. (10 mm)	7/8 in. (22 mm)	3/8 in. (10 mm)	7/8 in. (22 mm)	L15-65 15 ft. - 50 ft. (4.6 m - 15 m)
-60	3/8 in. (10 mm)	1-1/8 in. (29 mm)	3/8 in. (10 mm)	1-1/8 in. (29 mm)	Field Fabricated

NOTE - Units are designed for line sets of up to fifty feet (15m).

Installing Refrigerant Line

During the installation of any heat pump or a/c system, it is important to properly isolate the refrigerant lines to prevent unnecessary vibration. Line set contact with the structure (wall, ceiling or floor) causes some objectionable noise when vibration is translated into sound. As a result, more energy or vibration can be expected. Closer attention to line set isolation must be observed.

Following are some points to consider when placing and installing a high-efficiency outdoor unit:

- 1- Placement** - Be aware some localities are adopting sound ordinances based on how noisy the unit is from the adjacent property not at the original installation. Install the unit as far as possible from the property line. When possible, do not install the unit directly outside a window. Glass has a very high level of sound transmission.
- 2- Line Set Isolation** - The following illustrations demonstrate procedures which ensure proper refrigerant line set isolation. Figure 7 shows how to install line sets on vertical runs. Figure 8 shows how to install line sets on horizontal runs. Figure 9 shows how to make a transition from horizontal to vertical. Finally, figure 10 shows how to place the outdoor unit and line set.

**Refrigerant Line Sets
How To Install Vertical Runs
(new construction shown)**

NOTE - Similar installation practices should be used if line set is to be installed on exterior of outside wall.

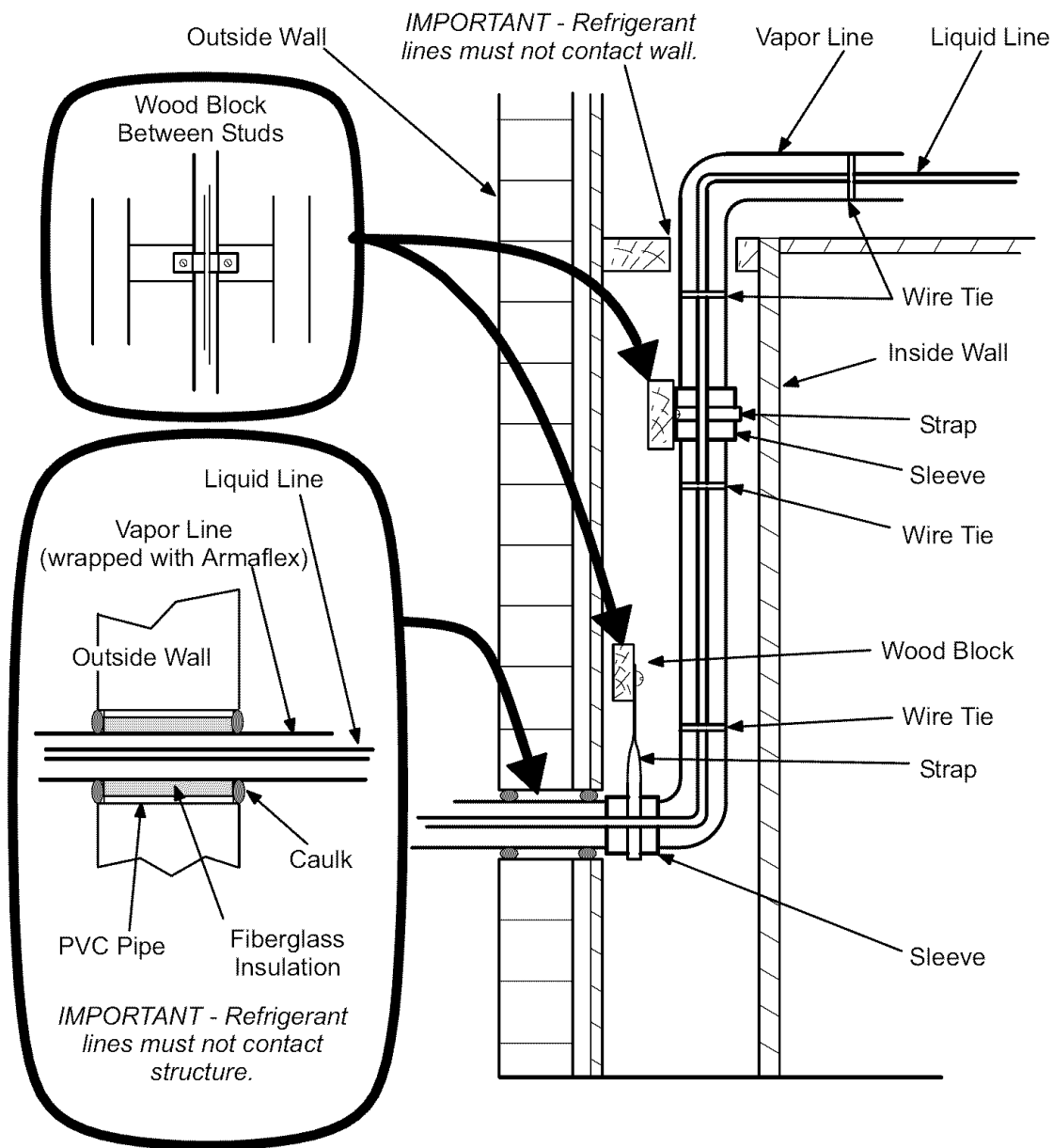

Figure 7

Refrigerant Line Sets: Installing Horizontal Runs

To hang line set from joist or rafter, use either metal strapping material or anchored heavy nylon wire ties.

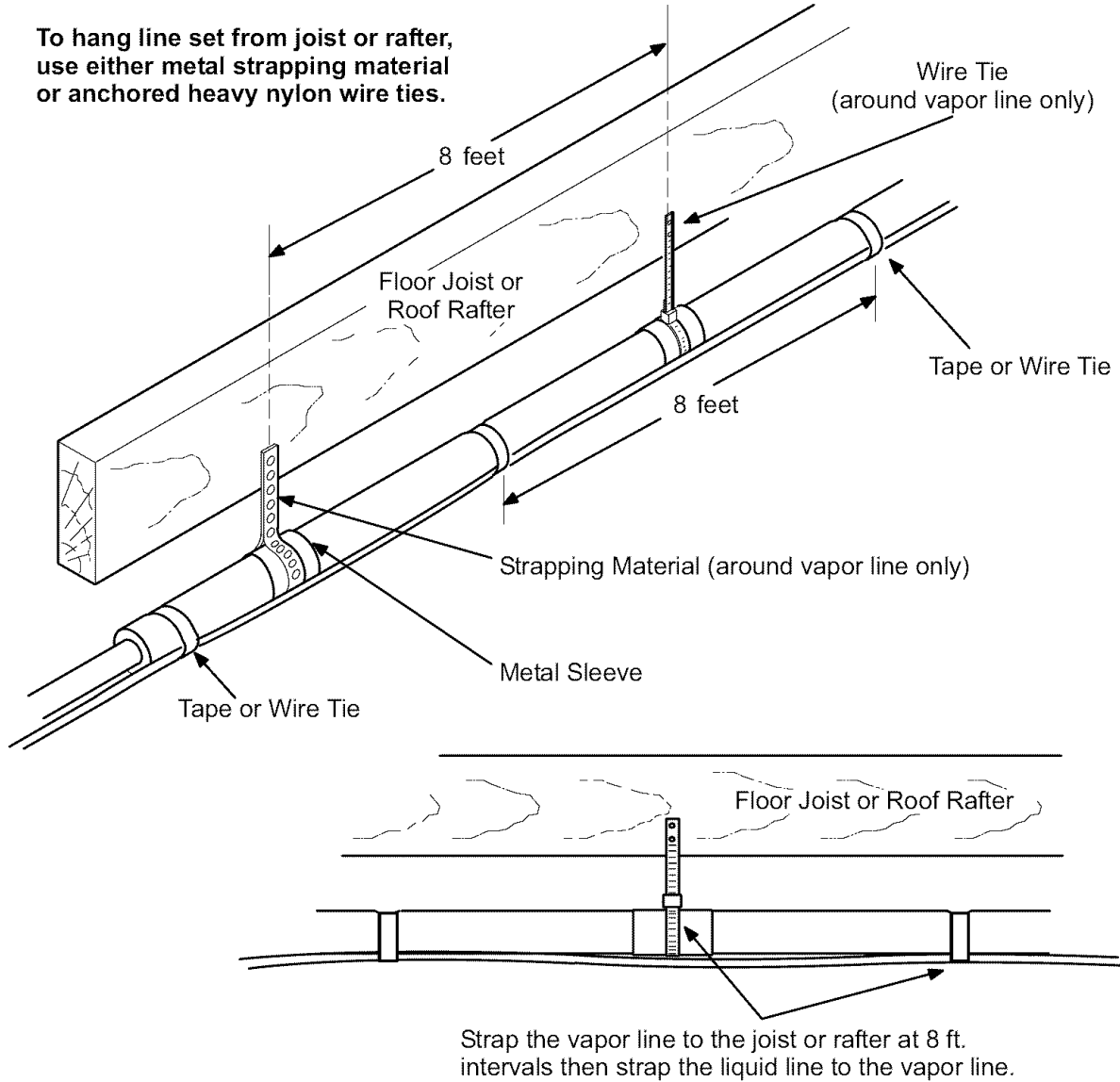

Figure 8

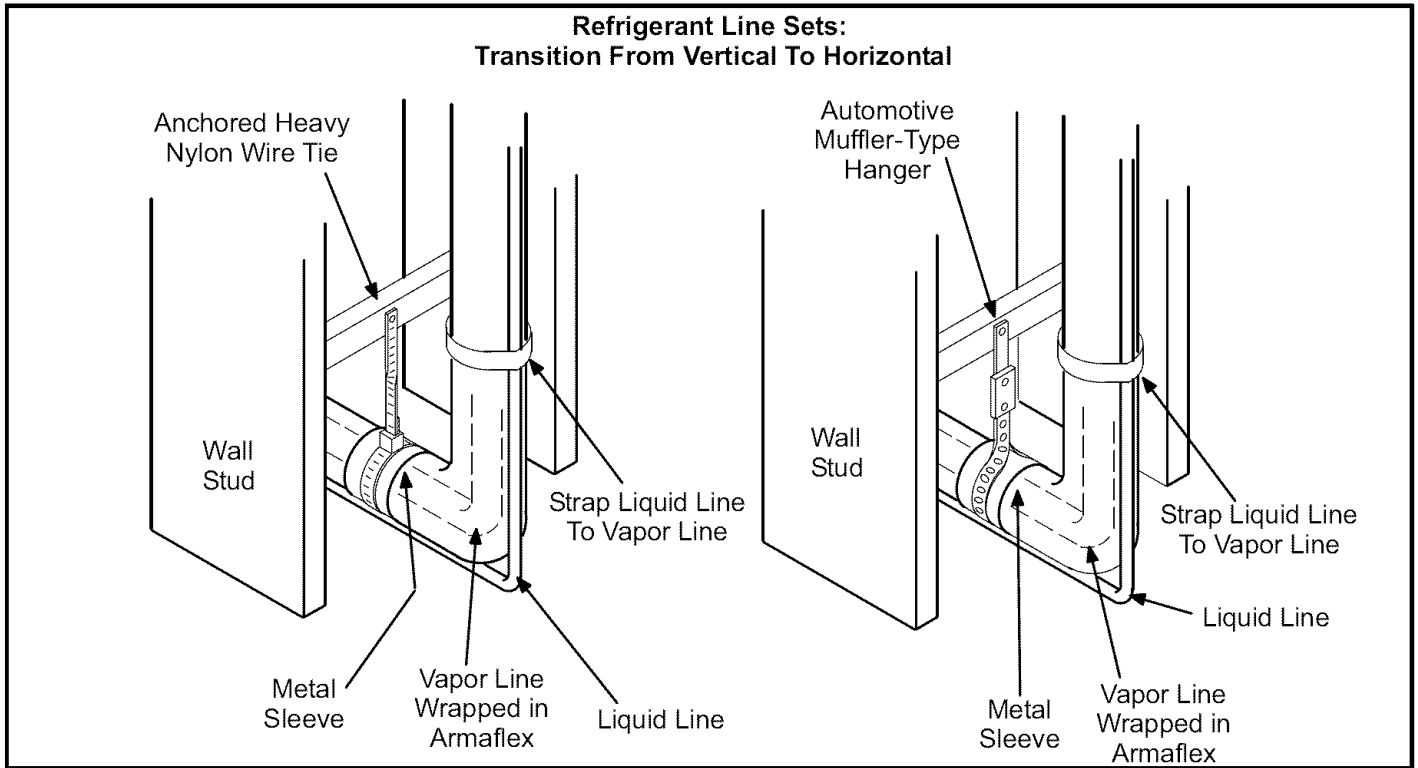

Figure 9

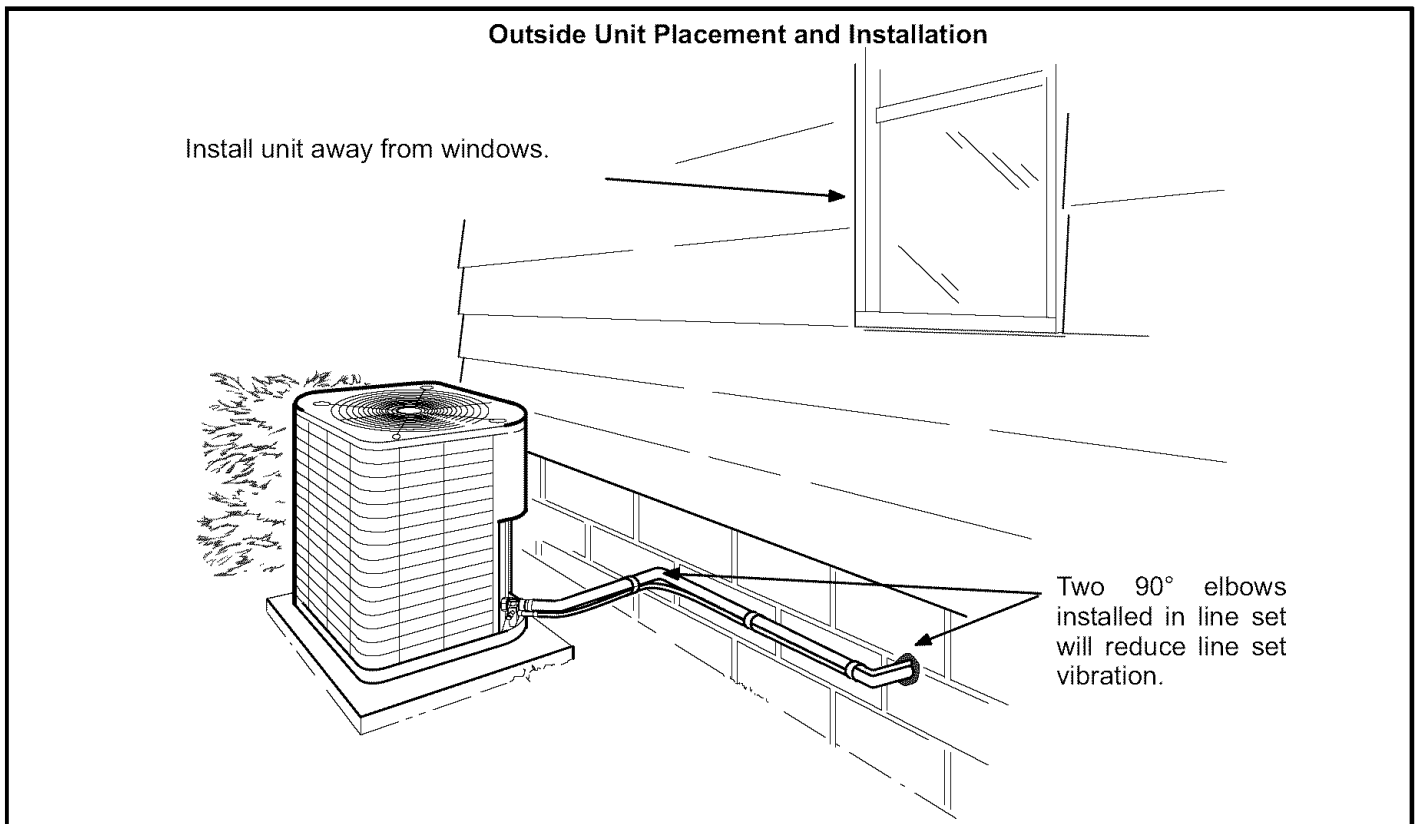

Figure 10

⚠ WARNING

Polyol ester (POE) oils used with R410A refrigerant absorb moisture very quickly. It is very important that the refrigerant system be kept closed as much as possible. **DO NOT** remove line set caps or service valve stub caps until you are ready to make connections.

Brazing Connection Procedure

- 1 - Cut ends of the refrigerant lines square (free from nicks or dents). Debur the ends. The pipe must remain round, do not pinch end of the line.
- 2 - Before making line set connections, use dry nitrogen to purge the refrigerant piping. This will help to prevent oxidation and the introduction of moisture into the system.
- 3 - Use silver alloy brazing rods (5 or 6 percent minimum silver alloy for copper-to-copper brazing or 45 percent silver alloy for copper-to-brass or copper-to-steel brazing) which are rated for use with R410A refrigerant. Wrap a wet cloth around the valve body and the copper tube stub. Remove light maroon washers from service valves and shield light maroon stickers in order to protect them during brazing. Braze the line set to the service valve.
- 4 - Wrap a wet cloth around the valve body and copper tube stub to protect it from heat damage during brazing. Wrap another wet cloth underneath the valve body to protect the base paint.
NOTE - The tube end must stay bottomed in the fitting during final assembly to ensure proper seating, sealing and rigidity.
- 5 - Install a field-provided thermal expansion valve (approved for use with R410A refrigerant) in the liquid line at the indoor coil.

Flushing Existing Line Set & Indoor Coil

⚠ WARNING



Danger of fire. Bleeding the refrigerant charge from only the high side may result in the low side shell and suction tubing being pressurized. Application of a brazing torch while pressurized may result in ignition of the refrigerant and oil mixture - check the high and low pressures before unbrazing.

⚠ IMPORTANT

If this unit is being matched with an approved line set or indoor coil which was previously charged with R22 refrigerant, or if it is being matched with a coil which was manufactured before January of 1999, the coil and line set must be flushed prior to installation. Take care to empty all existing traps. Polyol ester (POE) oils are used in Lennox units charged with R410A refrigerant. Residual mineral oil can act as an insulator, preventing proper heat transfer. It can also clog the thermal expansion valve, reducing system performance and capacity. Failure to properly flush the system per the instructions below will void the warranty.

⚠ CAUTION

This procedure should not be performed on systems which contain contaminants (Example: compressor burn out).

Required Equipment

You will need the following equipment in order to flush the existing line set and indoor coil: two clean R22 recovery bottles, an oilless recovery machine with a pump down feature, and two sets of gauges (one for use with R22 and one for use with the R410A).

Flushing Procedure

- 1 - Remove existing R22 refrigerant using the appropriate procedure below.
If the existing outdoor unit is not equipped with shut-off valves, or if the unit is not operational AND you plan to use the existing R22 refrigerant to flush the system -- Disconnect all power to the existing outdoor unit. Connect the existing unit, a **clean** recovery cylinder and the recovery machine according to the instructions provided with the recovery machine. Remove all R22 refrigerant from the existing system. Refer to gauges after shutdown to confirm that the entire system is completely void of refrigerant. Disconnect the liquid and vapor lines from the existing outdoor unit.
If the existing outdoor unit is equipped with manual shut-off valves AND you plan to use NEW R22 refrigerant to flush the system -- Start the existing R22 system in the cooling mode and close the liquid line valve. Pump all of the existing R22 refrigerant back into the outdoor unit. (It may be necessary to bypass the low pressure switches to ensure complete refrigerant evacuation.) When the low side system pressures reach 0 psig, close the vapor line valve. Disconnect all power to the existing outdoor unit. Refer to

gauges after shutdown to confirm that the valves are not allowing refrigerant to flow back into the low side of the system. Disconnect the liquid and vapor lines from the existing outdoor unit.

- 2 - Remove the existing outdoor unit. Set the new R410A unit and follow the brazing connection procedure which begins on the previous page to make line set connections. **DO NOT install provided R410A check/expansion valve at this time.** Make low voltage and line voltage connections to the new outdoor unit. **DO NOT turn on power to the unit or open the outdoor unit service valves at this time.**

- 3 - Remove the existing refrigerant flow control orifice or thermal expansion/check valve before continuing with flushing procedures. The existing devices are not approved for use with R410A refrigerant and may prevent proper flushing. Use a field-provided fitting to reconnect the lines.

⚠ IMPORTANT

The line set and indoor coil must be flushed with at least the same amount of clean refrigerant that previously charged the system. Check the charge in the flushing cylinder before proceeding.

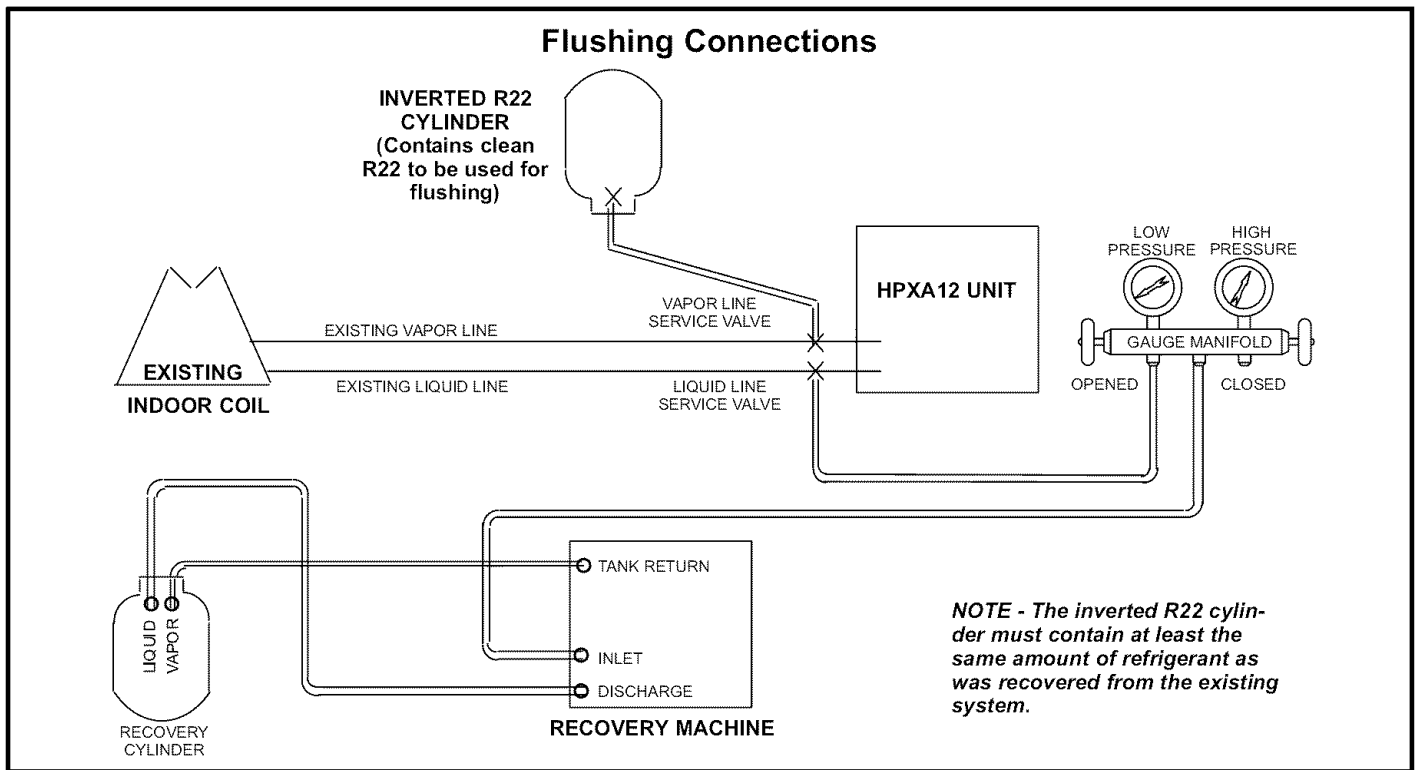

Figure 11

- 4 - Remove the pressure tap valve cores from the HPXA12 unit's service valves. Connect an R22 cylinder with clean refrigerant to the vapor service valve. Connect the R22 gauge set to the liquid line valve and connect a recovery machine with an empty recovery tank to the gauge set.
- 5 - Set the recovery machine for liquid recovery and start the recovery machine. Open the gauge set valves to allow the recovery machine to pull a vacuum on the existing system line set and indoor coil.
- 6 - Invert the cylinder of clean R22 and open its valve to allow liquid refrigerant to flow into the system through the vapor line valve. Allow the refrigerant to pass from the cylinder and through the line set and the indoor coil before it enters the recovery machine.
- 7 - After all of the liquid refrigerant has been recovered, switch the recovery machine to vapor recovery so that all of the R22 vapor is recovered. All the recovery machine to pull a vacuum on the system.

*NOTE - A single system flush should remove all of the mineral oil from the existing refrigerant lines and indoor coil. A second flushing may be done (using clean refrigerant) if insufficient amounts of mineral oil were removed during the first flush. **Each time the system is flushed, you must allow the recovery machine to pull a vacuum on the system at the end of the procedure.***

- 8 - Close the valve on the inverted R22 drum and the gauge set valves. Pump the remaining refrigerant out of the recovery machine and turn the machine off.
- 9 - Use nitrogen to break the vacuum on the refrigerant lines and indoor coil before removing the recovery machine, gauges and R22 refrigerant drum. Reinstall pressure tap valve cores into HPXA12 service valves.
- 10 - Install the provided check/expansion valve (approved for use with R410A refrigerant) in the liquid line at the indoor coil.

Refrigerant Metering Device

HPXA12 units are applicable to check expansion valve systems only. See indoor coil installation instructions and the Lennox engineering handbook for approved R410A TXV match-ups and application information.

NOTE - R410A systems will not operate properly with an R-22 valve.

Check Expansion Valve Systems

Check expansion valves equipped with either Chatleff or flare-type fittings are available from Lennox. Refer to the Engineering Handbook for applicable expansion valves for use with specific match-ups. See table 2 for applicable check and expansion valve kits.

If you install a check expansion valve with an indoor coil that includes a fixed orifice, remove the orifice before the check expansion valve is installed.

⚠ IMPORTANT

Failure to remove RFC when installing an expansion valve to the indoor coil will result in improper operation and damage to the system.

**Table 2
Indoor Check Expansion Valve Kits**

Model	Kit Catalog Number
HPXA12-018 HPXA12-024 HPXA12-030 HPXA12-036	49L24
HPXA12-042 HPXA12-048 HPXA12-060	49L25

See figure 12 for installation of the check expansion valve.

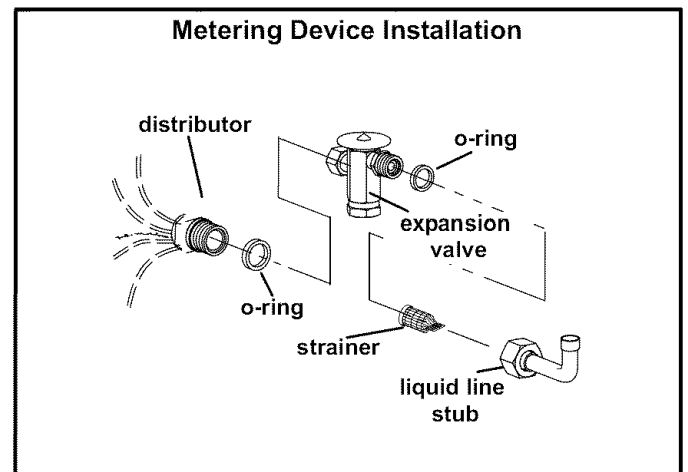

Figure 12

Manifold Gauge Set

Manifold gauge sets used with systems charged with R410A refrigerant must be capable of handling the higher system operating pressures. The gauges should be rated for use with pressures of 0 - 800 on the high side and a low side of 30" vacuum to 250 psi with dampened speed to 500 psi. Gauge hoses must be rated for use at up to 800 psi of pressure with a 4000 psi burst rating.

Service Valves

The liquid line and vapor line service valves (figures 13 and 14) and gauge ports are used for leak testing, evacuating, charging and checking charge. See table 3 for torque requirements.

Each valve is equipped with a service port which has a factory-installed Schrader valve. A service port cap protects the Schrader valve from contamination and serves as the primary leak seal.

**Table 3
Torque Requirements**

Part	Recommended Torque	
Service valve cap	8 ft.- lb.	11 NM
Sheet metal screws	16 in.- lb.	2 NM
Machine screws #10	28 in.- lb.	3 NM
Compressor bolts	90 in.- lb.	10 NM
Gauge port seal cap	8 ft.- lb.	11 NM

⚠ IMPORTANT

Service valves are closed to the outdoor unit and open to line set connections. Do not open until refrigerant lines have been leak tested and evacuated. All precautions should be exercised in keeping the system free from dirt, moisture and air.

To Access Schrader Port:

- 1 - Remove service port cap with an adjustable wrench.
- 2 - Connect gauge to the service port.
- 3 - When testing is completed, replace service port cap. Tighten finger tight, then an additional 1/6 turn.

To Open Service Valve:

- 1 - Remove stem cap using an adjustable wrench.
- 2 - Use a service wrench with a hex head extension to back the stem out counterclockwise as far as it will go.
NOTE - Use a 3/16" hex head extension for liquid line sizes or a 5/16" extension for vapor line sizes.
- 3 - Replace stem cap, and tighten it firmly. Tighten finger tight, then tighten an additional 1/6 turn.

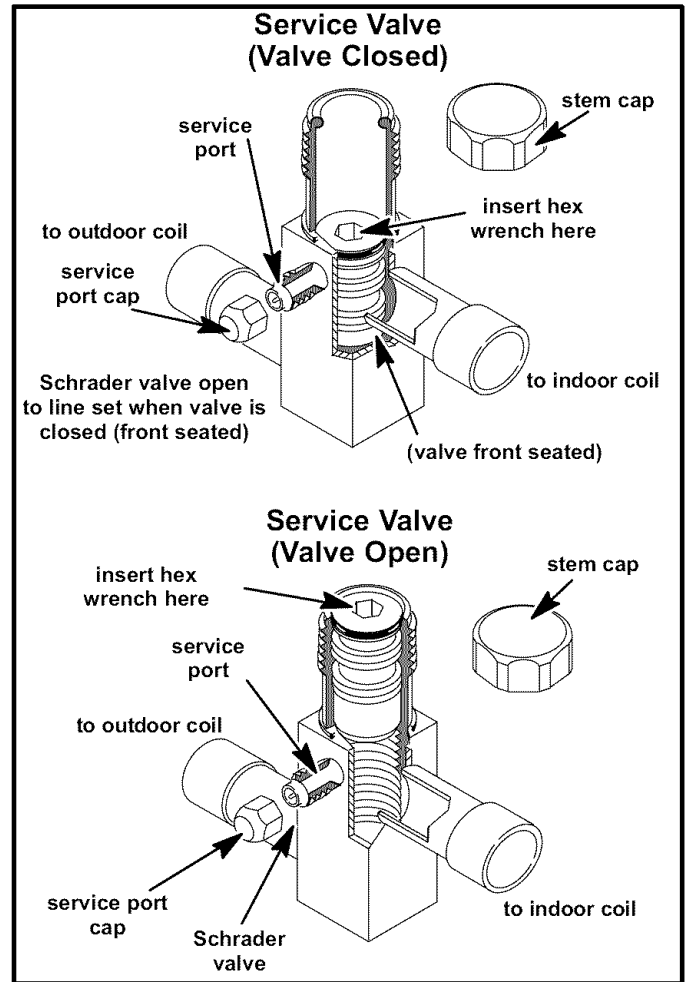

Figure 13

To Close Service Valve:

- 1 - Remove stem cap with an adjustable wrench.
- 2 - Use a service wrench with a hex head extension to turn the stem clockwise to seat the valve. Tighten firmly.
NOTE - Use a 3/16" hex head extension for liquid line sizes or a 5/16" extension for vapor line sizes.
- 3 - Replace stem cap. Tighten finger tight, then tighten an additional 1/6 turn.

Ball-Type Vapor Valve

Vapor line service valves function the same way as the other valves, the difference is in the construction. These valves are not rebuildable. If a valve has failed, you must replace it. A ball valve valve is illustrated in figure 14.

The ball valve is equipped with a service port with a factory-installed Schrader valve. A service port cap protects the Schrader valve from contamination and assures a leak-free seal.

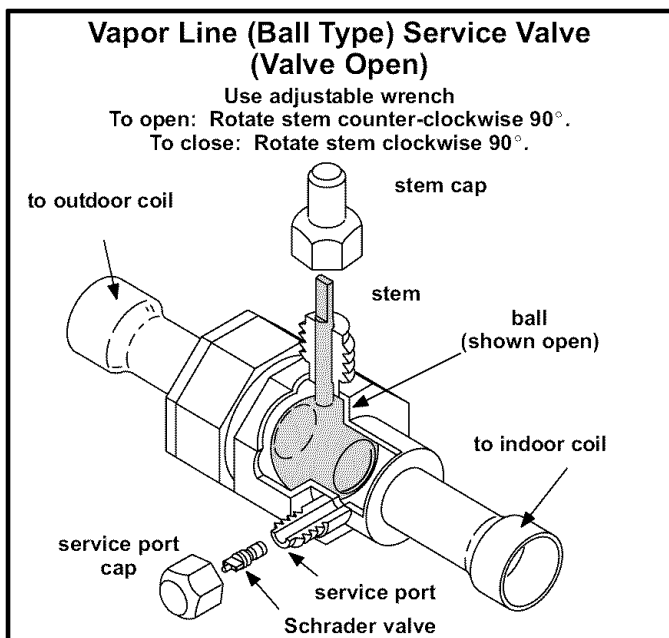

Figure 14

Leak Testing

After the line set has been connected to the indoor and outdoor units, check the line set connections and indoor unit for leaks.

⚠ WARNING

Refrigerant can be harmful if it is inhaled. Refrigerant must be used and recovered responsibly.

⚠ WARNING



Danger of explosion: Can cause equipment damage, injury or death. Never use oxygen to pressurize a refrigeration or air conditioning system. Oxygen will explode on contact with oil and could cause personal injury.

⚠ WARNING

Danger of explosion: Can cause equipment damage, injury or death. When using a high pressure gas such as dry nitrogen to pressurize a refrigeration or air conditioning system, use a regulator that can control the pressure down to 1 or 2 psig (6.9 to 13.8 kPa).

Using an Electronic Leak Detector

- 1 - Connect a cylinder of R410A to the center port of the manifold gauge set.
- 2 - With both manifold valves closed, open the valve on the R410A cylinder (vapor only).
- 3 - Open the high pressure side of the manifold to allow the R410A into the line set and indoor unit. Weigh in a trace amount of R410A. [A trace amount is a maximum of 2 ounces (57 g) or 3 pounds (31 kPa) pressure.] Close the valve on the R410A cylinder and the valve on the high pressure side of the manifold gauge set. Disconnect the R410A cylinder.
- 4 - Connect a cylinder of nitrogen with a pressure regulating valve to the center port of the manifold gauge set.
- 5 - Connect the manifold gauge set high pressure hose to the vapor valve service port. (Normally, the high pressure hose is connected to the liquid line port; however, connecting it to the vapor port better protects the manifold gauge set from high pressure damage.)
- 6 - Adjust the nitrogen pressure to 150 psig (1034 kPa). Open the valve on the high side of the manifold gauge set which will pressurize line set and indoor unit.
- 7 - After a few minutes, open a refrigerant port to ensure the refrigerant you added is adequate to be detected. (Amounts of refrigerant will vary with line lengths.) Check all joints for leaks. Purge nitrogen and R410A mixture. Correct any leaks and recheck.

⚠ IMPORTANT

Leak detector must be capable of sensing HFC refrigerant.

Evacuation

Evacuating the system of noncondensables is critical for proper operation of the unit. Noncondensables are defined as any gas that will not condense under temperatures and pressures present during operation of an air conditioning system. Noncondensables and water vapor combine with refrigerant to produce substances that corrode copper piping and compressor parts.

⚠ IMPORTANT

Use a thermocouple or thermistor electronic vacuum gauge that is calibrated in microns. Use an instrument that reads from 50 microns to at least 10,000 microns.

- 1 - Connect manifold gauge set to the service valve ports as follows:
 - low pressure gauge to *vapor* line service valve
 - high pressure gauge to *liquid* line service valve
- 2 - Connect micron gauge.
- 3 - Connect the vacuum pump (with vacuum gauge) to the center port of the manifold gauge set.
- 4 - Open both manifold valves and start the vacuum pump.
- 5 - Evacuate the line set and indoor unit to an **absolute pressure** of 23,000 microns (29.01 inches of mercury). During the early stages of evacuation, it is desirable to close the manifold gauge valve at least once to determine if there is a rapid rise in **absolute pressure**. A rapid rise in pressure indicates a relatively large leak. If this occurs, repeat the leak testing procedure.

*NOTE - The term **absolute pressure** means the total actual pressure within a given volume or system, above the absolute zero of pressure. Absolute pressure in a vacuum is equal to atmospheric pressure minus vacuum pressure.*
- 6 - When the absolute pressure reaches 23,000 microns (29.01 inches of mercury), close the manifold gauge valves, turn off the vacuum pump and disconnect the manifold gauge center port hose from vacuum pump. Attach the manifold center port hose to a nitrogen cylinder with pressure regulator set to 150 psig (1034 kPa) and purge the hose. Open the manifold gauge valves to break the vacuum in the line set and indoor unit. Close the manifold gauge valves.

⚠ WARNING

Danger of Equipment Damage. Avoid deep vacuum operation. Do not use compressors to evacuate a system. Extremely low vacuums can cause internal arcing and compressor failure. Damage caused by deep vacuum operation will void warranty.

- 7 - Shut off the nitrogen cylinder and remove the manifold gauge hose from the cylinder. Open the manifold gauge valves to release the nitrogen from the line set and indoor unit.
- 8 - Reconnect the manifold gauge to the vacuum pump, turn the pump on, and continue to evacuate the line set and indoor unit until the absolute pressure does not rise above 500 microns (29.9 inches of mercury) within a 20-minute period after shutting off the vacuum pump and closing the manifold gauge valves.
- 9 - When the absolute pressure requirement above has been met, disconnect the manifold hose from the vacuum pump and connect it to an upright cylinder of R410A refrigerant. Open the manifold gauge valves to break the vacuum from 1 to 2 psig positive pressure in the line set and indoor unit. Close manifold gauge valves and shut off the R410A cylinder and remove the manifold gauge set.

Start-Up

⚠ IMPORTANT

Crankcase heater (if applicable) should be energized 24 hours before unit start-up to prevent compressor damage as a result of slugging.

- 1 - Rotate fan to check for frozen bearings or binding.
- 2 - Inspect all factory and field-installed wiring for loose connections.
- 3 - After evacuation is complete, open the liquid line and vapor line service valves (counterclockwise) to release refrigerant charge (contained in outdoor unit) into the system.
- 4 - Replace stem caps and secure finger tight, then tighten an additional (1/6) one-sixth of a turn.
- 5 - Check voltage supply at the disconnect switch. The voltage must be within the range listed on the unit nameplate. If not, do not start the equipment until the power company has been consulted and the voltage condition has been corrected.

- 6 - Set the thermostat for a cooling demand, turn on power to indoor blower unit and close the outdoor unit disconnect to start the unit.
- 7 - Recheck voltage while the unit is running. Power must be within range shown on the nameplate.

Charging

This system is charged with R410A refrigerant which operates at much higher pressures than R22. The recommended check expansion valve is approved for use with R410A. Do not replace it with a valve that is designed to be used with R22. This unit is NOT approved for use with coils that include metering orifices or capillary tubes.

Processing Procedure

The unit is factory-charged with the amount of R410A refrigerant indicated on the unit rating plate. This charge is

based on a matching indoor coil and outdoor coil with a 15 foot (4.6 m) line set. For varying lengths of line set, refer to table 2 for refrigerant charge adjustment. A blank space is provided on the unit rating plate to list the actual field charge.

Table 4

Liquid Line Set Diameter	Oz. per 5 ft. (grams per 1.5 m) adjust from 15 ft. (4.6 m) line set*
3/8 in. (10 mm)	3 ounces per 5 feet (85 g per 1.5 m)

*If line length is greater than 15 ft. (4.6 m), add this amount. If line length is less than 15 ft. (4.6 m), subtract this amount.

⚠ IMPORTANT

Mineral oils are not compatible with R410A. If oil must be added, it must be a polyol ester oil.

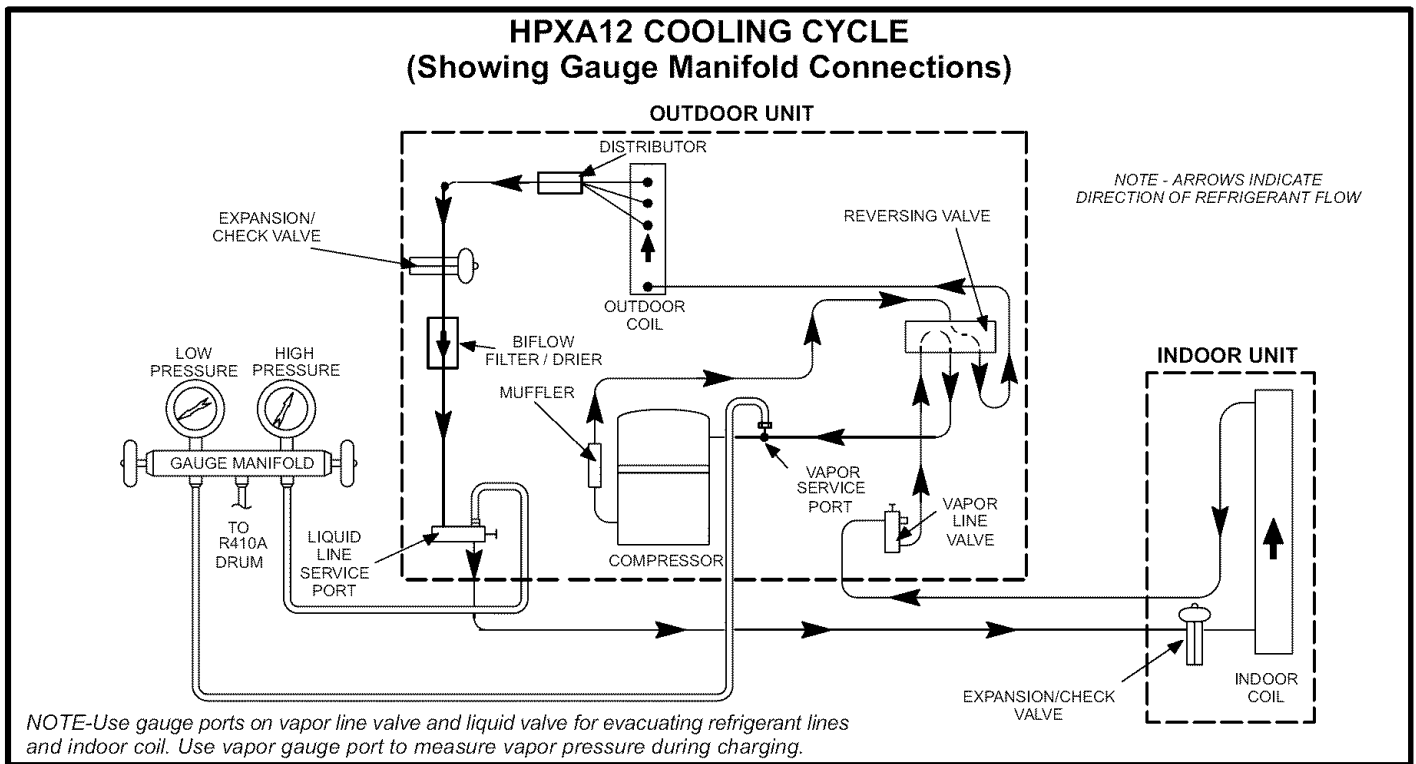

Figure 15

The outdoor unit should be charged during warm weather. However, applications arise in which charging must occur in the colder months. *The method of charging is determined by the unit's refrigerant metering device and the outdoor ambient temperature.*

Measure the liquid line temperature and the outdoor ambient temperature as outlined below:

- 1 - Connect the manifold gauge set to the service valves:
 - low pressure gauge to *vapor* valve service port
 - high pressure gauge to *liquid* valve service port

Close manifold gauge set valves. Connect the center manifold hose to an upright cylinder of R410A. See figure 15.

- 2 - Set the room thermostat to call for heat. This will create the necessary load for properly charging the system in the cooling cycle.
- 3 - Use a digital thermometer to record the outdoor ambient temperature.
- 4 - When the heating demand has been satisfied, switch the thermostat to cooling mode with a set point of 68°F (20°C). When pressures have stabilized, use a digital thermometer to record the liquid line temperature.
- 5 - The outdoor temperature will determine which charging method to use. Proceed with the appropriate charging procedure.

Weighing in the Charge TXV Systems – Outdoor Temp < 65°F (18°C)

If the system is void of refrigerant, or if the outdoor ambient temperature is cool, the refrigerant charge should be weighed into the unit. Do this after any leaks have been repaired.

- 1 - Recover the refrigerant from the unit.
- 2 - Conduct a leak check, then evacuate as previously outlined.
- 3 - Weigh in the unit nameplate charge.

If weighing facilities are not available or if you are charging the unit during warm weather, follow one of the other procedures outlined below.

Subcooling Method Outdoor Temp. < 65°F (18°C)

When the outdoor ambient temperature is below 65°F (18°C), use the subcooling method to charge the unit. It may be necessary to restrict the air flow through the outdoor coil to achieve pressures in the 325-375 psig (2240-2585 kPa) range. These higher pressures are necessary for checking the charge. Block equal sections of air intake panels and move obstructions sideways until the liquid pressure is in the 325-375 psig (2240-2585 kPa) range. See figure 16.

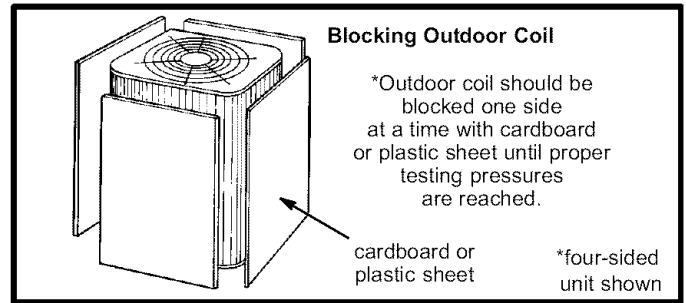

Figure 16

- 1 - With the manifold gauge hose still on the liquid service port and the unit operating stably, use a digital thermometer to record the liquid line temperature.
- 2 - At the same time, record the liquid line pressure reading.
- 3 - Read the liquid line pressure from the gauge and convert it to heat pump temperature using the temperature/pressure chart for R410A refrigerant provided in table 8.
- 4 - Subtract the liquid line temperature from the saturation temperature (according to the chart) to determine subcooling. **(Saturation temperature - Liquid line temperature = Subcooling)**
- 5 - Compare the subcooling value with those in table 5. If subcooling is greater than shown, recover some refrigerant. If subcooling is less than shown, add some refrigerant. **Some R410A cylinders are equipped with a dip tube which allows you to draw liquid refrigerant from the bottom of the cylinder without turning the cylinder upside-down. The cylinder will be marked if it is equipped with a dip tube.**

**Table 5
Subcooling Values for Charging**

Model Number	Subcooling Values Conversion Temp. - Liquid Line Temp. °F (°C)
HPXA12-18	8.5 (4.7)
HPXA12-24	12.5 (6.9)
HPXA12-30	5.5 (3.1)
HPXA12-36	8.5 (4.7)
HPXA12-42	8.5 (4.7)
HPXA12-48	7 (3.9)
HPXA12-60	7 (3.9)

Charging Using Normal Operating Pressures and the Approach Method Outdoor Temp. ≥ 65°F (18°C)

The following procedure is intended as a general guide and is for use on expansion valve systems only. For best results, indoor temperature should be 70°F (21°C) to 80°F (26°C). Monitor system pressures while charging.

- 1 - Record outdoor ambient temperature using a digital thermometer.
- 2 - Attach high pressure gauge set and operate unit for several minutes to allow system pressures to stabilize.

3 - Compare stabilized pressures with those provided in table 7, "Normal Operating Pressures." Minor variations in these pressures may be expected due to differences in installations. Significant differences could mean that the system is not properly charged or that a problem exists with some component in the system. Pressures higher than those listed indicate that the system is overcharged. Pressures lower than those listed indicate that the system is undercharged. Verify adjusted charge using the approach method.

Approach Method

- 4 - Use the same digital thermometer used to check outdoor ambient temperature to check liquid line temperature. Verify the unit charge using the approach method. The difference between the ambient and liquid temperatures should match values given in table 6. Add refrigerant to lower the approach temperature and remove it to increase the approach temperature. Loss of charge results in low capacity and efficiency.
- 5 - If the values do not agree with the those in table 6, add refrigerant to lower the approach temperature or recover refrigerant from the system to increase the approach temperature.

**Table 6
Approach Values for Charging**

Model Number	Approach Temperature Liquid Line Temp. - Outdoor Ambient °F (°C)
HPXA12-18	5 (2.8)
HPXA12-24	8.0 (4.4)
HPXA12-30	12.5 (6.9)
HPXA12-36	13 (7.2)
HPXA12-42	13 (7.2)
HPXA12-48	8.5 (4.7)
HPXA12-60	12 (6.7)

! IMPORTANT

Use table 7 as a general guide when performing maintenance checks. This is not a procedure for charging the unit (Refer to Charging/Checking Charge section). Minor variations in these pressures may be expected due to differences in installations. Significant differences could mean that the system is not properly charged or that a problem exists with some component in the system.

**Table 7
Normal Operating Pressures
(Liquid ±10 and Vapor ±5 psig)**

Cooling Operation														
Outdoor Coil Entering Air Temp. °F (°C)	HPXA12-18		HPXA12-24		HPXA12-30		HPXA12-36		HPXA12-42		HPXA12-48		HPXA12-60	
	Liquid	Vapor	Liquid	vapor	Liquid	Vapor	Liquid	Vapor	Liquid	Vapor	Liquid	Vapor	Liquid	Vapor
65 (18.3)	223	147	254	130	244	136	262	135	260	133	240	126	250	123
75 (23.9)	270	149	290	134	282	139	304	138	300	135	280	130	300	132
85 (29.4)	312	150	335	137	325	141	349	141	345	137	320	134	345	137
95 (35.0)	360	152	382	140	375	143	399	143	397	139	360	136	378	140
105 (40.6)	406	154	433	143	426	145	454	146	452	142	415	137	430	142
115 (46.1)	463	155	490	146	485	147	514	149	510	145	470	139	497	145
Heating Operation														
Outdoor Coil Entering Air Temp. °F (°C)	HPXA12-18		HPXA12-24		HPXA12-30		HPXA12-36		HPXA12-42		HPXA12-48		HPXA12-60	
	Liquid	Vapor	Liquid	Vapor	Liquid	Vapor	Liquid	Vapor	Liquid	Vapor	Liquid	Vapor	Liquid	Vapor
20 (-6.6)	265	63	295	59	340	60	278	59	288	60	315	60	282	57
30 (-1.1)	280	78	315	72	350	75	290	72	297	70	325	74	300	70
40 (4.4)	294	96	335	87	362	90	305	89	310	85	340	90	310	82
50 (10.0)	310	112	350	103	374	110	317	105	325	105	360	106	325	92
60 (15.5)	320	133	375	120	390	132	333	128	344	127	380	128	335	100

**Table 8
R410A Temperature/Pressure Chart**

Temp. °F	Pressure Psig	Temp. °F	Pressure Psig	Temp. °F	Pressure Psig	Temp. °F	Pressure Psig
32	100.8	63	178.5	94	290.8	125	445.9
33	102.9	64	181.6	95	295.1	126	451.8
34	105.0	65	184.3	96	299.4	127	457.6
35	107.1	66	187.7	97	303.8	128	463.5
36	109.2	67	190.9	98	308.2	129	469.5
37	111.4	68	194.1	99	312.7	130	475.6
38	113.6	69	197.3	100	317.2	131	481.6
39	115.8	70	200.6	101	321.8	132	487.8
40	118.0	71	203.9	102	326.4	133	494.0
41	120.3	72	207.2	103	331.0	134	500.2
42	122.6	73	210.6	104	335.7	135	506.5
43	125.0	74	214.0	105	340.5	136	512.9
44	127.3	75	217.4	106	345.3	137	519.3
45	129.7	76	220.9	107	350.1	138	525.8
46	132.2	77	224.4	108	355.0	139	532.4
47	134.6	78	228.0	109	360.0	140	539.0
48	137.1	79	231.6	110	365.0	141	545.6
49	139.6	80	235.3	111	370.0	142	552.3
50	142.2	81	239.0	112	375.1	143	559.1
51	144.8	82	242.7	113	380.2	144	565.9
52	147.4	83	246.5	114	385.4	145	572.8
53	150.1	84	250.3	115	390.7	146	579.8
54	152.8	85	254.1	116	396.0	147	586.8
55	155.5	86	258.0	117	401.3	148	593.8
56	158.2	87	262.0	118	406.7	149	601.0
57	161.0	88	266.0	119	412.2	150	608.1
58	163.9	89	270.0	120	417.7	151	615.4
59	166.7	90	274.1	121	423.2	152	622.7
60	169.6	91	278.2	122	428.8	153	630.1
61	172.6	92	282.3	123	434.5	154	637.5
62	195.5	93	286.5	124	440.2	155	645.0

System Operation

The outdoor unit and indoor blower cycle on demand from the room thermostat. When the thermostat blower switch is in the **ON** position, the indoor blower operates continuously.

Service Light Operation

The thermostat is not included with the unit and must be purchased separately. Some outdoor thermostats incorporate isolating contacts and an emergency heat function (which includes an amber indicating light). The service light thermostat will enable the emergency heat light function on the room thermostat.

Emergency Heat (Amber Light)

An emergency heat function is designed into some room thermostats. This feature is applicable when isolation of the outdoor unit is required, or when auxiliary electric heat is staged by outdoor thermostats. When the room thermostat is placed in the emergency heat position, the outdoor unit control circuit

is isolated from power and field-provided relays bypass the outdoor thermostats. An amber indicating light simultaneously comes on to remind the homeowner that he is operating in the emergency heat mode.

Emergency heat is usually used during an outdoor unit shutdown, but it should also be used following a power outage if power has been off for over an hour and the outdoor temperature is below 50°F (10°C). System should be left in the emergency heat mode at least six hours to allow the crankcase heater sufficient time to prevent compressor slugging.

Filter Drier

The unit is equipped with a large-capacity biflow filter drier which keeps the system clean and dry. If replacement is necessary, order another of the same design and capacity. The replacement filter drier must be suitable for use with R410A refrigerant.

Defrost System

Low Pressure Switch

The HPXA12 is equipped with an auto-reset low pressure switch which is located on the vapor line. The switch shuts off the compressor when the vapor pressure falls below the factory setting. This switch is ignored during defrost operation and when the outdoor temperature goes below 15°F. The switch closes when it is exposed to 60 psig and opens at 25 psig. It is not adjustable.

High Pressure Switch

The HPXA12 is equipped with an auto-reset high pressure switch (single-pole, single-throw) which is located on the liquid line. The switch shuts off the compressor when discharge pressure rises above the factory setting. The switch is normally closed and is permanently adjusted to trip (open) at 640 ± 10 psig (4412 ± 69 kPa).

NOTE - A Schrader core is under the pressure switches.

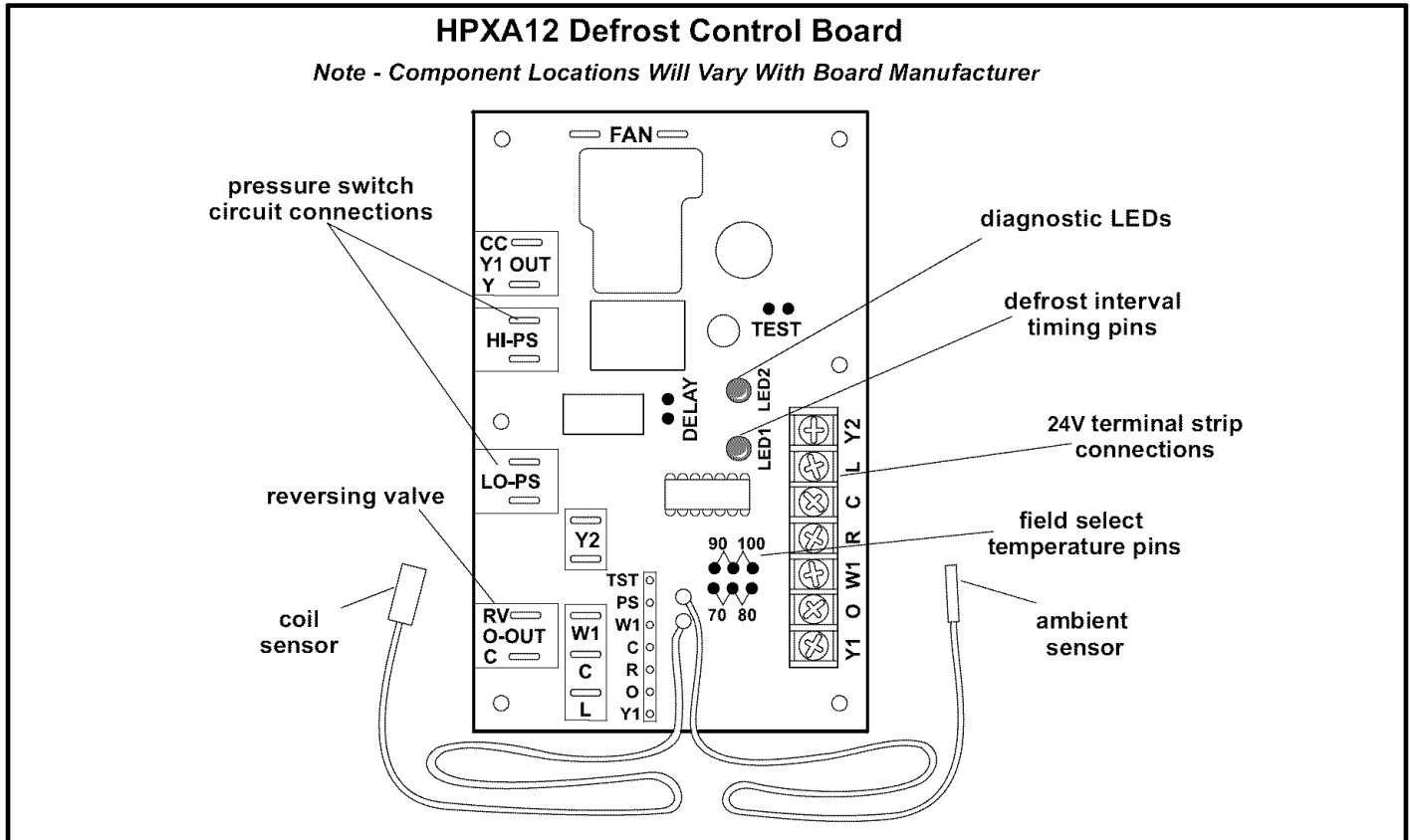

Figure 17

Demand Defrost System

The demand defrost controller uses basic differential temperature means to detect when the system performs poorly because of ice build-up on the outdoor coil. The controller also uses “self-calibrating” principles to calibrate itself when the system starts and after every time the system defrosts. The control board has the following components: defrost relays, anti-short cycle timed-off control, pressure switch/safety control, 5-trip lockout circuit, manufacturing test mode, ambient and coil temperature sensors, field selectable termination temperature pins, and a field low voltage connection terminal strip. See figure 17.

The control monitors ambient temperature, outdoor coil temperature and total run time to determine when a defrost cycle is required. Two temperature probes are permanently attached to the control. The coil temperature probe is designed with a spring clip to allow mounting to the outside coil tubing. The location of the coil sensor is important for proper defrost operation.

NOTE - The logic of the demand defrost board accurately measures the performance of the system as frost accumulates on the outdoor coil. This typically will translate into longer running time between defrost cycles as more frost accumulates on the outdoor coil before the board initiates defrost cycles.

The temperature probes cannot be removed from the control. The control and the attached probes MUST be replaced as a unit. Do not attempt to cut or splice probe wires.

Diagnostic LEDs

The defrost board uses two LEDs for diagnostics. The LEDs flash a specific sequence according to the diagnostic condition. See table 9.

HI-PS/LO-PS Terminals

The unit's automatic reset pressure switches are wired to the PS terminals. The high-pressure switch is factory wired to the HI-PS terminal, and the low-pressure switch is factory-wired to LO-PS terminal.

The path between Y1 (input) and Y1 Out is interlocked through the pressure switches. When one of the pressure switches trip, the board will cycle off the compressor and the 5-strike counter in the board will count one strike.

5-Strike Lockout Feature

- The internal control logic of the board counts the pressure switch trips only while the Y1 (Input) line is active. If a pressure switch opens and closes twice during a Y1 (Input), the control logic will reset the pressure switch trip counter to zero at the end of the Y1 (Input). If the pressure switch opens for a fifth time during the current Y1 (Input), the control will enter a lockout condition.
- The 5-strike pressure switch lockout condition can be reset by cycling OFF the 24-volt power to the control board or by shorting the TEST pins. All timer functions (run times) will also be reset.
- If a pressure switch opens while the Y1 Out line is engaged, a 5-minute short cycle will occur after the switch closes.

Delay Mode

The defrost board has a field-selectable function to reduce occasional sounds that may occur while the unit is cycling in and out of the defrost mode. When a jumper is installed on the DELAY pins, the compressor will be cycled off for 30 seconds going in and out of the defrost mode. Units are shipped with jumper installed on DELAY pins.

NOTE - The 30 second off cycle is not functional when jumpering the TEST pins.

Operational Description

The defrost control board has three basic operational modes: normal, defrost, and calibration.

Normal Mode

The demand defrost board monitors the O line, to determine the system operating mode (heat/cool), outdoor ambient temperature, coil temperature (outdoor coil) and compressor run time to determine when a defrost cycle is required.

Defrost Mode

Refer to table 9 for demand defrost operation.

Calibration Mode

The board is considered uncalibrated when power is applied to the board, after cool mode operation, or if the coil temperature exceeds the termination temperature when it is in heat mode. Calibration of the board occurs after a defrost cycle to ensure that there is no ice on the coil. During calibration, the temperature of both the coil and the ambient sensor are measured to establish the temperature differential which is required to allow a defrost cycle.

**Table 9
Defrost Control Board Diagnostic Led**

LED 1	LED 2	Condition	Possible Cause(s)	Solution
OFF	OFF	Power problem	1 No power (24V) to board terminals R & C. 2 Board failure.	1 Check control transformer power (24V). 2 If power is available and LED(s) are unlit, replace board and all sensors.
ON	ON	Coil sensor problem	1 Coil temperature outside of sensor range. 2 Faulty sensor wiring connections at board or poor sensor contact on coil. 3 Sensor failure.	1 Sensor function will resume when coil temperature is between -20°F and 110°F. 2 Check sensor wiring connections at board and sensor contact on coil. 3 Replace board and all sensors.
OFF	ON	Ambient sensor problem	1 Ambient temperature outside of sensor range. 2 Faulty sensor wiring connections at board or sensor. 3 Sensor failure.	1 Sensor function will resume when coil temperature is between -20°F and 110°F. 2 Check sensor wiring connections at board and sensor. 3 Replace board and all sensors.
FLASH	FLASH	Normal operation	Unit operating normally or in standby mode.	None required.
ON	OFF	5-Strike pressure lockout (Short test pins or reset 24V power to board to override lockout)	1 Restricted air flow over indoor or outdoor coil. 2 Improper refrigerant charge.	1 Remove any blockages or restrictions. Check outdoor fan motor for proper operation. 2 Check approach, superheat & sub-cooling temperatures.
ON	FLASH	Low pressure switch circuit open during Y1 demand	3 Improper metering device operation.	3 Check system pressures. Repair leaks. Replace metering device.
FLASH	ON	High pressure switch circuit open during Y1 demand	4 Poor contact between coil sensor and coil.	4 Make sure that sensor is properly positioned on coil and that firm contact is established. Refer to service manual for proper placement.
ALTERNATING FLASH	ALTERNATING FLASH	5-minute delay (Jumper test pins to override delay)	Thermostat demand for cooling or outdoor operation. Unit operating in 5-minute anti-short-cycle mode.	None required.

Demand Defrost Operation

The demand defrost control board initiates a defrost cycle based on either frost detection or time.

Frost Detection - If the compressor runs longer than 34 minutes and the actual difference between the clear coil and frosted coil temperatures exceeds the maximum difference allowed by the control, a defrost cycle will be initiated.

IMPORTANT - The demand defrost control board will allow a greater accumulation of frost and will initiate fewer defrost cycles than a time/temperature defrost system.

Time - If 6 hours of heating mode compressor run time has elapsed since the last defrost cycle while the coil temperature remains below 35°F (2°C), the demand defrost control will initiate a defrost cycle.

Actuation - When the reversing valve is de-energized, the Y1 circuit is energized, and the coil temperature is below 35°F (2°C), the board logs the compressor run time. If the board is not calibrated, a defrost cycle will be initiated after 34 minutes of heating mode compressor run time. The control will attempt to self-calibrate after this (and all other) defrost cycle(s). Calibration success depends on stable system temperatures during the 20-minute calibration period. If the board fails to calibrate, another defrost cycle will be initiated after 90 minutes of heating mode compressor run time. Once the defrost board is calibrated, it will use demand defrost logic to initiate a defrost cycle. A demand defrost system initiates defrost when the difference between the clear coil and frosted coil temperatures exceeds the maximum difference allowed by the control OR after 6 hours of heating mode compressor run time has been logged since the last defrost cycle.

Termination - The defrost cycle ends when the coil temperature exceeds the termination temperature or after 14 minutes of defrost operation. If the defrost is terminated by the 14-minute timer, another defrost cycle will be initiated after 34 minutes of run time.

Test Mode - When Y1 is energized and 24V power is being applied to the board, a test cycle can be initiated by placing the termination temperature jumper across the "Test" pins for 2 to 5 seconds. If the jumper remains across the "Test" pins longer than 5 seconds, the control will ignore the test pins and revert to normal operation. The jumper will initiate one cycle per test.

Maintenance

⚠ WARNING



Electric shock hazard. Can cause injury or death. Before attempting to perform any service or maintenance, turn the electrical power to unit OFF at disconnect switch(es). Unit may have multiple power supplies.

Maintenance and service must be performed by a qualified installer or service agency. At the beginning of each cooling season, the system should be checked as follows:

Outdoor Unit

- 1 - Clean and inspect outdoor coil (may be flushed with a water hose). Ensure power is off before cleaning.
- 2 - Outdoor unit fan motor is pre-lubricated and sealed. No further lubrication is needed.
- 3 - Visually inspect all connecting lines, joints and coils for evidence of oil leaks.
- 4 - Check all wiring for loose connections.
- 5 - Check for correct voltage at unit (unit operating).
- 6 - Check amp draw on outdoor fan motor.
Unit nameplate _____ Actual _____.
- 7 - Inspect drain holes in coil compartment base and clean if necessary.

NOTE - If insufficient heating or cooling occurs, the unit should be gauged and refrigerant charge should be checked.

Indoor Coil

- 1 - Clean coil if necessary.
- 2 - Check connecting lines, joints and coil for evidence of oil leaks.
- 3 - Check condensate line and clean if necessary.

Indoor Unit

- 1 - Clean or change filters.
- 2 - Lennox blower motors are prelubricated and permanently sealed. No more lubrication is needed.
- 3 - Adjust blower speed for cooling. Measure the pressure drop over the coil to determine the correct blower CFM. Refer to the unit information service manual for pressure drop tables and procedure.
- 4 - *Belt Drive Blowers* - Check belt for wear and proper tension.
- 5 - Check all wiring for loose connections.
- 6 - Check for correct voltage at unit. (blower operating)
- 7 - Check amp draw on blower motor.
Motor nameplate _____ Actual _____.

Optional Accessories

Refer to the Engineering Handbook for optional accessories that may apply to this unit. The following may or may not apply:

- Loss of Charge Kit
- High Pressure Switch Kit
- Compressor Monitor
- Compressor Crankcase Heater
- Hail Guards
- Mounting Bases
- Stand-off Kit
- Sound Cover
- Low Ambient Kit
- Monitor Kit
- Mild Weather Kit

Homeowner Information

In order to ensure peak performance, your system must be properly maintained. Clogged filters and blocked airflow prevent your unit from operating at its most efficient level.

Ask your Lennox dealer to show you where your indoor unit's filter is located. It will be either at the indoor unit (installed internal or external to the cabinet) or behind a return air grille in the wall or ceiling. Check the filter monthly and clean or replace it as needed.

Disposable filters should be replaced with a filter of the same type and size. If you are unsure about the filter you need for your system, call your Lennox dealer for assistance.

⚠ IMPORTANT

Turn off electrical power to the unit at the disconnect switch before performing any maintenance. The unit may have multiple power supplies.

Many indoor units are equipped with reusable foam filters. These filters can be cleaned with a mild soap and water solution. Rinse the filter thoroughly and let it dry completely before it is returned to the unit or grille.

The filter and all access panels must be in place any time the unit is in operation.

Your system may be equipped with an electronic air cleaner which will provide respiratory relief by removing up to 90 percent of all airborne particles which pass through it. If it is, ask your dealer to instruct you on its maintenance.

Your indoor coil is equipped with a drain pan to collect condensate formed as your system removes humidity from the inside air. Have your dealer show you where the main condensate drain (and auxiliary drain, if applicable) runs and how to check the drain for any obstruction.

It is also very important to provide unrestricted airflow to the outdoor unit. Leaves, trash or shrubs crowding the unit cause the outdoor unit to work harder and use more energy. Keep shrubbery trimmed away from the unit and period-

ically check for debris which may have collected around the unit.

Heat Pump Operation

Your new Lennox heat pump has several characteristics that you should be aware of:

Your heat pump satisfies heating demand by delivering large amounts of warm air into the living space. This is quite different from gas- or oil-fired furnaces or an electric furnace which deliver lower volumes of considerably hotter air to heat the space.

Do not be alarmed if you notice frost on the outdoor coil in the winter months. Frost develops on the outdoor coil during the heating cycle when temperatures are below 45°F (7°C). An electronic control activates a defrost cycle lasting 5 to 15 minutes at preset intervals to clear the outdoor coil of the frost. During the defrost cycle, you may notice steam rising from the outdoor unit. This is a normal occurrence. The thermostat may engage auxiliary heat during the defrost cycle to satisfy a heating demand; however, the unit will return to normal operation at the conclusion of the defrost cycle.

Your Lennox HPXA12 heat pump is equipped with a compressor crankcase heater which protects the compressor from refrigerant slugging during cold weather operation. If power to your unit has been interrupted for several hours or more, set the room thermostat selector to the "Emergency Heat" setting to obtain temporary heat without the risk of serious equipment damage. In this operating mode, all heating demand will be satisfied by auxiliary heat. Compressor operation is locked out during Emergency Heat operation. After a six-hour compressor crankcase heater warm-up period, the thermostat can be switched to the "Heat" setting and normal operation will resume.

Thermostat Operation

Though your thermostat may vary somewhat from the description below, its operation will be similar.

Temperature Setting Levers

Most heat pump thermostats have two temperature selector levers: one for heating and one for cooling. Set the levers or dials to the desired temperature setpoints for both heating and cooling. Avoid frequent temperature adjustment; turning the unit off and back on before pressures equalize puts stress on the unit compressor.

Fan Switch

In AUTO or INT (intermittent) mode, the blower operates only when the thermostat calls for heating or cooling. This mode is generally preferred when humidity control is a priority. The ON or CONT mode provides continuous indoor blower operation, regardless of whether the compressor or auxiliary heat are operating. This mode is required when constant air circulation or filtering is desired.

System Switch

Set the system switch for heating, cooling or auto operation. The auto mode allows the heat pump to automatically switch from heating mode to cooling mode to maintain predetermined comfort settings. Many heat pump thermostats are also equipped with an emergency heat mode which locks out heat pump operation and provides temporary heat supplied by the auxiliary heat.

Indicating Light

Most heat pump thermostats have an amber light which indicates when the heat pump is operating in the emergency heat mode.

Temperature Indicator

The temperature indicator displays the actual room temperature.

Programmable Thermostats

Your Lennox system may be controlled by a programmable thermostat. These thermostats provide the added feature of programmable time-of-day setpoints for both heating and cooling. Refer to the user's information manual provided with your particular thermostat for operation details.

Preservice Check

If your system fails to operate, check the following before calling for service:

- Check to see that all electrical disconnect switches are ON.
- Make sure the room thermostat temperature selector is properly set.
- Make sure the room thermostat system switch is properly set.
- Replace any blown fuses, or reset circuit breakers.
- Make sure unit access panels are in place.
- Make sure air filter is clean.
- Locate and record unit model number before calling.

HPXA12 Check List

Start-Up and Performance Check List

Job Name _____ Job No. _____ Date _____

Job Location _____ City _____ State _____

Installer _____ City _____ State _____

Unit Model No. _____ Serial No. _____ Service Technician _____

Nameplate Voltage _____

Rated Load Ampacity _____ Amps: 1st stage _____ 2nd Stage _____

Maximum Fuse or Circuit Breaker _____

Electrical Connections Tight? Indoor Filter Clean? Supply Voltage (Unit Off) _____

Indoor Blower RPM _____ S.P. Drop Over Indoor (Dry) _____ Outdoor Coil Entering Air Temp. _____

Cooling (2nd stage)

Liquid Line Pressure _____ Vapor Pressure _____ Refrigerant Charge Checked?

Heating (2nd stage)

Liquid Line Pressure _____ Vapor Pressure _____ Refrigerant Charge Checked?

Refrigerant Lines: Leak Checked? Properly Insulated? Outdoor Fan Checked?

Service Valves Fully Opened? Service Valve Caps Tight? Voltage With Compressor Operating _____

Sequence of Operation

Thermostat

Heating Correct Cooling Correct Calibrated? Properly Set? Level?