

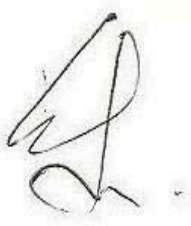

PRODUCT APPROVAL DATASHEET

PRODUCT	MCSLogic Class 2 Bluetooth Module
MODEL NAME	MB0402C2
CUSTOMER	LG Electronics

Checked By	Approved By	Company Seal
		

MCSLOGIC

Revision History

Version	Date	Revision Description
0.1	11/05/27	First release
0.2	11/06/03	Changed Pin Description
0.3	11/07/08	Changed Label Information
0.4	11/07/15	Changed Dimension
0.5	11/07/21	Changed BOM
0.6	11/08/17	Changed Mechanical Dimension
0.7	11/09/20	Derating release
0.9	11/09/28	Add PCB Layout
1.0	11/09/29	Changed Label Information

Table of Contents

1.1 GENERAL DESCRIPTION	4
1.2 QUALITY	4
1.3 TEST	4
1.4 BLOCK DIAGRAM	5
1.5 PIN DESCRIPTIONS.....	6
1.6 ELECTRICAL CHARACTERISTICS.....	7
1.7 RELIABILITY TEST CONDITIONS	10
1.8 MODULE'S LABEL INFORMATION	11
1.9 MECHANICAL DIMENSION	12
1.10 BILL OF MATERIALS	14
1.11 PACKING INFORMATION	15
1.12 TRAY	15
1.13 INNER BOX.....	16
1.14 OUTER BOX.....	17
1.15 PACKAGE RELIABILITY TEST CONDITIONS	18
1.16 MODULE POSITION GUIDE	19

1.1 General Description

MB0402C2 is a fully integrated Bluetooth module. It is based on CSR's Bluecore4-ROM with specific interface design to meet LG Electronics's needs.

MB0402C2 is compatible with Bluetooth specification version 2.1. It integrates RF, Baseband controller, etc., a completed Bluetooth subsystem.

Features :

- Operation Range (Class II) : 10 meters
- Operating Temperature Range : -10 °C ~ 80 °C
- Operating VDD Range : 3.0 V ~ 3.6V
- Interface : UART
- Internal Antenna
- Fully Compatible with Bluetooth Specification 2.1
- RoHS Compliant

Applications :

- Consumer Products

1.2 Quality

Quality should meet each condition which mentioned on this specification. However, the items which are not mentioned on this specification follow the inspection agreements and standards which are agree with both companies.

1.3 Test

Electrical characteristics are tested for every products. However, if there are any objection in judgement, it should be treated with agreements of companies.

1.5 Pin Descriptions

No	Pin Name	I/O	Description
1	VDD	I	Positive Input for the internal regulator (3.0 ~ 3.6V)
2	RESET	I	Reset if low. Input debounced so must be low for >5ms to cause a reset
3	RTS	O	Bluetooth UART Request to Send. Active-low request.
4	CTS	I	Bluetooth UART Clear to Send.Active-low clear.
5	TXD	O	Bluetooth UART Serial Output.
6	GND	-	Ground.
7	RXD	I	Bluetooth UART Serial Input.
8	GND	-	Ground

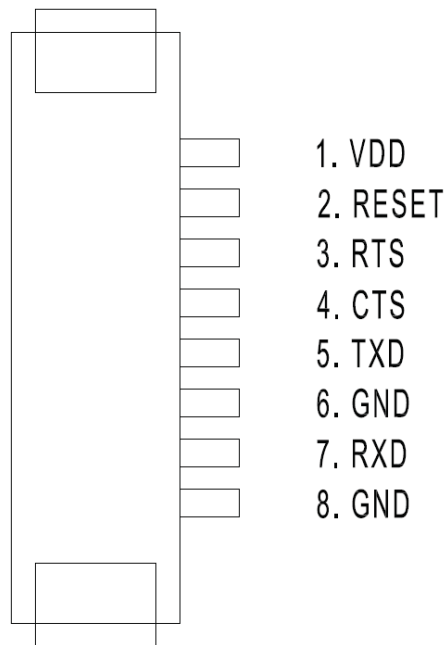

1.6 Electrical Characteristics

Conditions : VDD = 3.3V, Ta = 25 °C, unless otherwise noted.

Absolute Maximum Ratings

Parameter	Min	Max	Unit
Power Supply Voltage : VDD	-0.4V	3.6V	DCV
Storage Temperature	-40	85	°C

Recommended Operating Conditions

Parameter	Min	Max	Unit
Power Supply Voltage	3.0V	3.6V	DCV
Operation Temperature	-10	80	°C

Current consumption

Parameter	Avg	Peak	Unit
Standby	0.3	-	mA
TX-CW	57.6	63	mA
TX-Modulation	36	63	mA
RX	37.9	-	mA

Input/Output Characteristics

Parameter	Min	Max	Unit
V _{IL} Input Voltage Low	-0.4	0.8	V
V _{IH} Input Voltage High	0.7*VDD	VDD+0.4	V
V _{OL} Output Voltage Low	-	0.2	V
V _{OH} Output Voltage High	VDD-0.2	-	V

General Performance					
Parameter	Condition	Min	Type	Max	Unit
Frequency Range		2402		2480	MHz

Transmitter Performance					
Parameter	Condition	Min	Type	Max	Unit
Transmit Power		-6	0	4	dBm
Power density		-	-	20	dBm
20dB bandwidth				1000	KHz
Adjacent channel power	$\pm 2\%$	-	-	-20	dBm
	$\pm 3\%$	-	-	-40	dBm
	$\pm 4\%$	-	-	-40	dBm
Out-band Spurious Emission	30MHz ~ 1GHz	-	-	-36	dBm
	1GHz ~ 12.75GHz	-	-	-30	dBm
	1.8GHz ~ 1.9GHz	-	-	-47	dBm
	5.1GHz ~ 5.3GHz	-	-	-47	dBm
Modulation Characteristic	$\Delta F_{1\text{avg}}$	140	-	175	KHz
	$\Delta F_{2\text{max}}$	115	-	-	KHz
	$\Delta F_{2\text{avg}} / \Delta F_{1\text{avg}}$	80	-	-	%
Initial Carrier Frequency Tolerance	DH1 packet	-75	-	75	KHz
Carrier Frequency Drift	DH5 packet	-25		25	KHz

Receiver Performance					
Parameter	Condition	Min	Type	Max	Unit
Sensitivity at 0.1% BER	Single slot (DH1 packet)	-70	-	-	dBm
Sensitivity at 0.1% BER	Multi slot (DH5 packet)	-70	-	-	dBm
Maximum received signal at 0.1% BER		-20	-	-	dBm
Maximum level of intermodulation interferers	f1-f2 = 5 MHz, Pwanted= -64 dBm	-39	-	-	dBm

Derating

NO	ITEM	SIZE	VALUE	RATED V/C/W	INPUT VOLTAGE	INPUT CURRENT	USAGE RATIO
1	CL05F105ZQ5NNNC	1.0 X 0.5	1uF	6.3V	3.3V	-	52.38%
2	CL05B103KB5NNNC	1.0 X 0.5	10nF	50V	3.3V	-	6.60%
3	CL05B104KO5NNNC	1.0 X 0.5	100nF	50V	3.3V	-	6.60%
4	RC1005J222CS	1.0 X 0.5	2.2KΩ	1/16W	3.3V		0.0001%
5	CIH05T15NJ	1.0 X 0.5	15nH	300mA	3.3V	60mA	20%
6	CIH05T10NJ	1.0 X 0.5	10nH	300mA	1.8V	<0.01uA	<0.033%
7	CL05C221FB5NNNC	1.0 X 0.5	220pF	50V	1.8V		3.6%
8	CL05B103KB5NNNC	1.0 X 0.5	10nF	50V	1.8V		3.6%
9	CL05B104KO5NNNC	1.0 X 0.5	100nF	50V	1.8V		3.6%
10	CL05F105ZQ5NNNC	1.0 X 0.5	1uF	6.3V	1.8V		28.57%

1.7 Reliability Test Conditions

NO	ITEM	Condition	Characteristics
1	Constant Humidity Load Test	Initial value measured at standard test condition Test Conditions : 35 °C , 90% RH, 100hr 25 °C , 50% RH, 2hr Supply Voltage Condition : standard $\pm 5\%$	No electrical problem
2	High Temp Load Test	Initial value measured at standard test condition. Test Conditions : 25 °C \rightarrow 85 °C , 100hr (Within 1hr) Supply Voltage Condition : standard $\pm 5\%$	No electrical problem
3	Low Temp Load Test	Initial value measured at standard test condition. Test Conditions : 25 °C \rightarrow -40 °C , 100hr (Within 1hr) Supply Voltage Condition : standard $\pm 5\%$	No electrical problem
4	High Temp Storage Test	Initial value measured at standard test condition. Test Conditions : 85 °C , 100hr	No electrical problem
5	Low Temp Storage Test	Initial value measured at standard test condition. Test Conditions : -40 °C , 100hr	No electrical problem
6	Temperature Cycle	Initial value measured at standard test condition. Test Conditions : -40 °C \rightarrow 85 °C , 15min, 50cycle	No electrical problem
7	Vibration Test	Initial value measured at standard test condition. Test Conditions : - Freq : 10~55Hz, acceleration: 5G (Sine wave vibration) - Test time : X, Y, Z axis for 2hr	No electrical problem No mechanical damage
8	Drop Test	Initial value measured at standard test condition. Test Conditions : - Test height : 100cm - Test times : 10 times Drop the product onto a 10mm thickness plywood	No electrical problem No mechanical damage
9	ESD HBM	Initial value measured at standard test condition. Test Conditions : 2000V	No electrical problem No mechanical damage
10	ESD MM	Initial value measured at standard test condition. Test Conditions : 200V	No electrical problem No mechanical damage
11	Temperature Rising Test	Initial value measured at standard test condition. Test Conditions : 40 °C , 2hr Module Condition : A2DP Stream	BT IC : 42.1 °C EEPROM : 42 °C Crystal : 42.2 °C PCB : 41.2 °C Connector : 41.1 °C

1.8 Module's Label Information

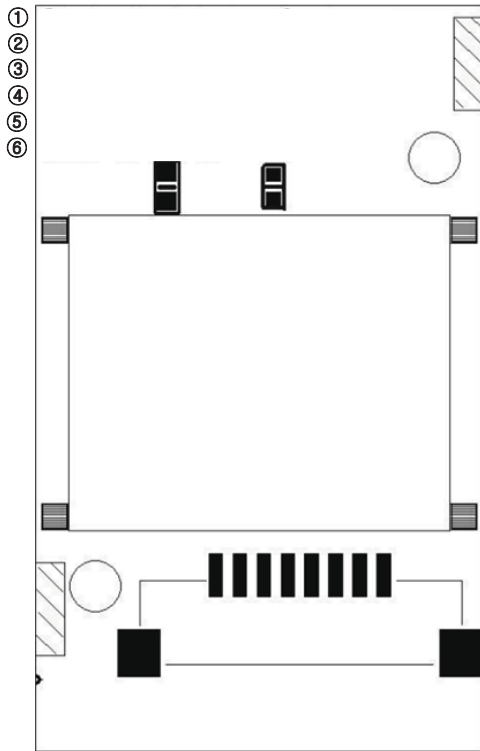

<module silk>



<label sheet>

No.	Description
①	Module Name
②	Model No. of MCSLogic
③	Part No. of LGE
④	Contains Transmitter FCC ID
⑤	Contains Transmitter IC
⑥	Manufacture Country
⑦	Japan's MIC Certification Logo
⑧	KCC Logo
⑨	Week Code (YY : Year, WC : Week Code)
⑩	LG Logo
⑪	NCC Certification Logo
⑫	CE Certification Logo

1.9 Mechanical Dimension

TOP View

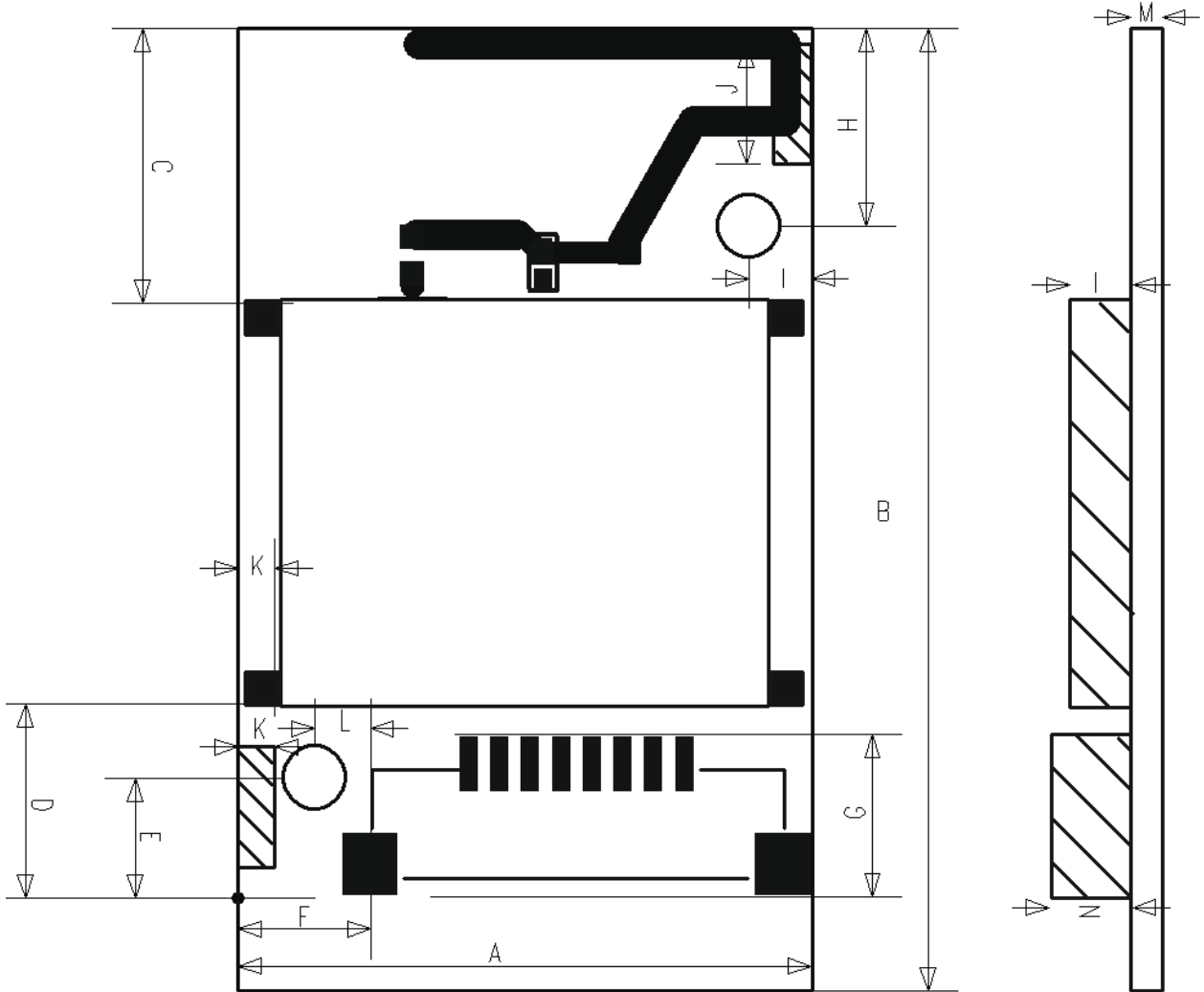

Mark	Dimension	Mark	Dimension	Mark	Dimension	Mark	Dimension	Mark	Dimension
A	18.60±0.5	D	6.30±0.3	G	5.24±0.3	J	3.90±0.3	M	1.00±0.3
B	31.20±0.3	E	3.90±0.3	H	6.40±0.3	K	1.20±0.3	N	2.60±0.3
C	8.90±0.3	F	4.30±0.3	I	2.00±0.3	L	1.80±0.3		

(Unit : mm)

PCB LAYOUT Layer 1

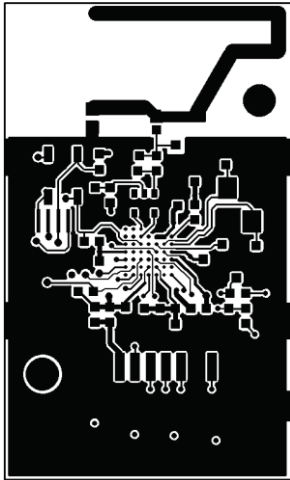

PCB LAYOUT Layer 2

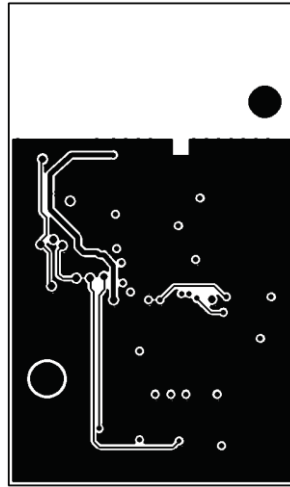

PCB LAYOUT Layer 3

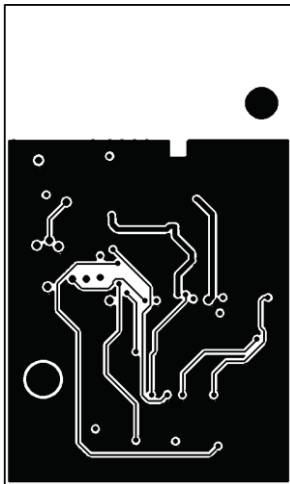

PCB LAYOUT Layer 4

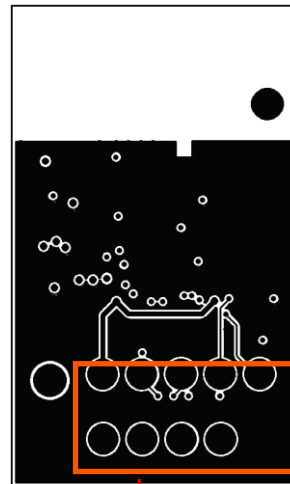

PCB Solder Mask

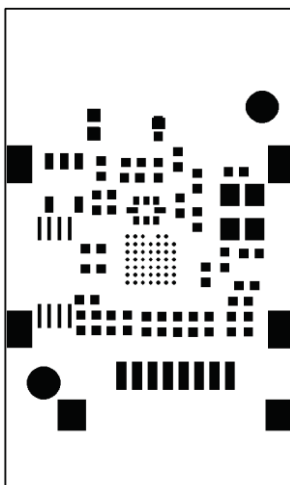

This metallic pads are not used in final products.

1.10 Bill of Materials

No	Q'ty	Circuit Ref	Description	Value	Package	Vendor	Part Name
1	2	R12, R13	Resistor	2.2R	1005	S.S.E.M	RC1005J2R2CS
2	3	R10, R16, R11,	Resistor	2.2kR	1005	S.S.E.M	RC1005J222CS
3	1	R41	Resistor	15pF	1608	S.S.E.M	CL10C150JB8NNNC
4	2	R14, R15	Resistor	100R	1005	S.S.E.M	RC1005J101CS
5	1	C20	Chip Ceramic	3.9pF	1005	S.S.E.M	CL05C3R9CB5NNNC
6	2	L10,L16	Chip Ceramic	0.5pF	1005	S.S.E.M	CL05C0R5BB5NNNC
7	1	L11	Chip Ceramic	1pF	1005	S.S.E.M	CL05C010CB5ANNC
8	1	C19	Chip Ceramic	6.8nH	1005	S.S.E.M	CIH05T6N8JNC
9	1	C21	Chip Ceramic	10pF	1005	S.S.E.M	CL05C100CB5NNNC
10	1	C13	Chip Ceramic	1nF	1005	S.S.E.M	CL05B102JB5NNNC
11	1	C24	Chip Ceramic	220pF	1005	S.S.E.M	CL05C221FB5NNNC
12	4	C11, C12, C16, C26	Chip Ceramic	10nF	1005	S.S.E.M	CL05B103KB5NNNC
13	3	C15, C27, C29	Chip Ceramic	100nF	1005	S.S.E.M	CL05B104KO5NNNC
14	2	C14, C17	Chip Ceramic	100pF	1005	S.S.E.M	CL05C101KB5NNNC
15	3	C22, C23, C28	Chip Ceramic	1uF	1005	S.S.E.M	CL05A105KQ5NNNC
16	1	C25	Chip Ceramic	5.6nH	1005	S.S.E.M	CIH05T5N6S
17	1	L14	Chip Ceramic	10nH	1005	S.S.E.M	CIH05T10NJ
18	1	L13	Chip Ceramic	15nH	1005	S.S.E.M	CIH05T15NJ
19	1	DIODE10	Chip Varistor		1005	JOINSET	ECVAL1005 05E20 100NBT
20	1	U10	BT CHIP		3.8x4.0	CSR	BC41B143A07-IXB-E4
21	1	U11	X-TAL	26MHz	3.2 x 2.5	PARTRON	CXC6X260000GHVRR70
22	1	U13	Balance Filter		2.0x1.25	AAC	BF24A4R218D8
23	1	U12	EEPROM		SOT-23	MICROCHIP	24AA16T-I/OT
					TSSOP	GIANTEC	GT24C16-2ZLI
24	1	CON10	Connector		10031HR-H08	YEONHO	10031HR-H08
25	1		Shield Can		16 X 13	HUMAN TECH	MB0402C2_SHIELD_CAN
26	1		PCB		31.2 X 18.6 X 1	A.P.G	MB0402C2

1.11 Packing Information

1.12 Tray

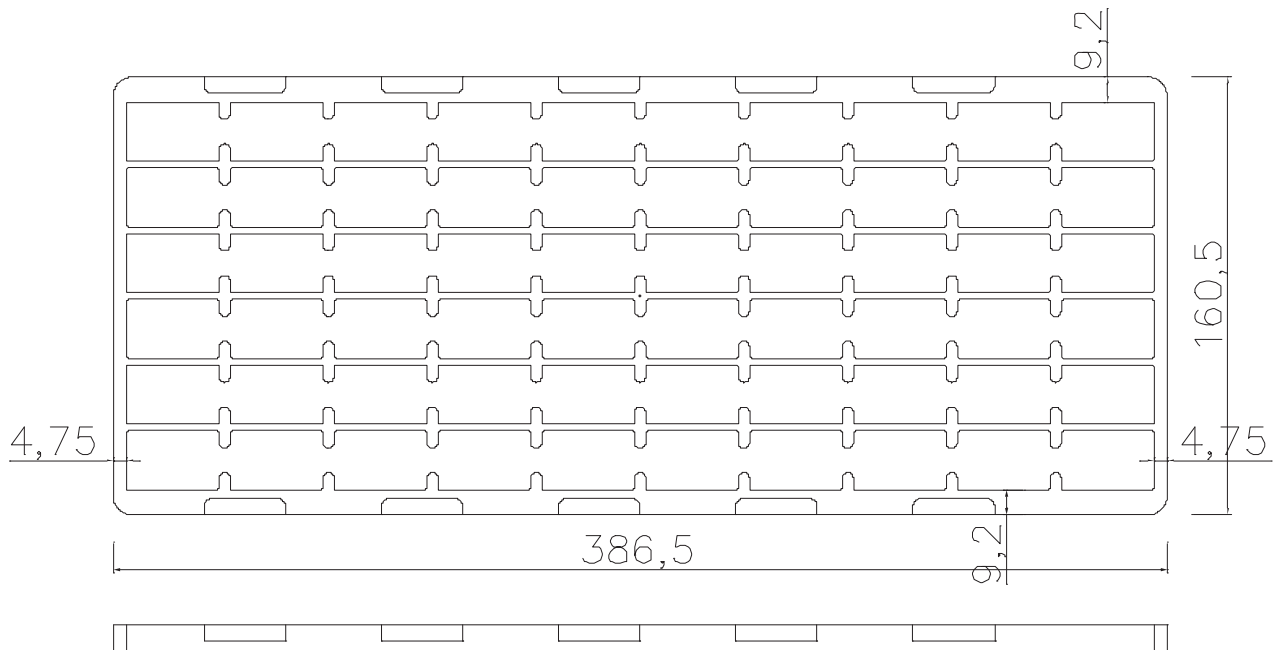

- Each tray has 60 units of products.

1.13 Inner Box

(Unit : mm)

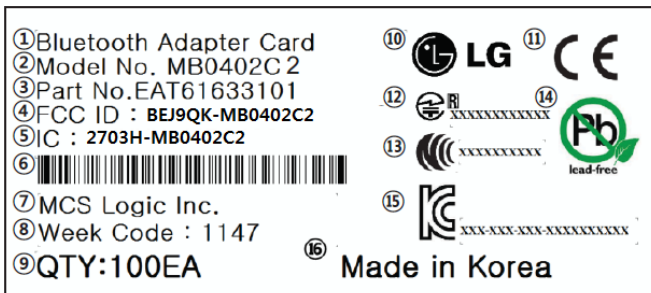
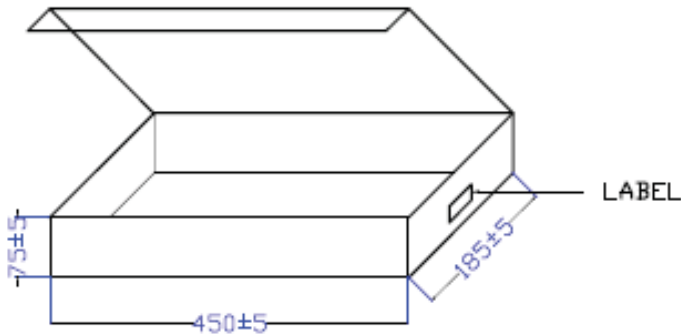

No.	Description
①	Module Name
②	Model No. of MCSLogic
③	Part No. of LGE
④	Contains Transmitter FCC ID
⑤	Contains Transmitter IC
⑥	Model Name Bar-Code
⑦	Manufacturer
⑧	Week Code (YY : Year, WC : Week Code)
⑨	Quantity
⑩	LG Logo
⑪	CE Certification Logo
⑫	Japan's MIC Certification Logo
⑬	NCC Certification Logo
⑭	RoHS Logo
⑮	KC Logo
⑯	Manufacture Country

1.14 Outter Box

(Unit : mm)

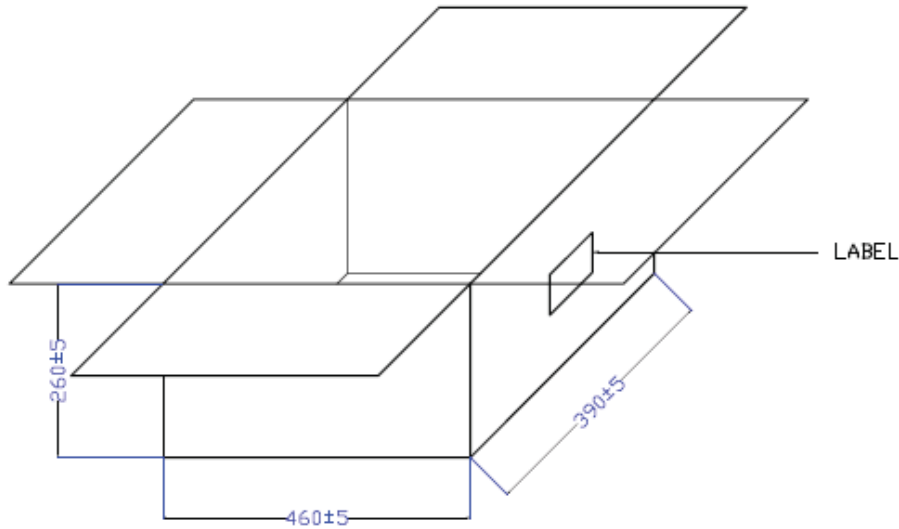

①MCS Logic Inc	②Address
③Customer	⑧Rohs
④Description	⑤Q'ty
	⑥G.weight(Kg)
	⑦C/T No.

No.	Description
①	Company
②	Company Address
③	Customer
④	Model No & LGE Part No.
⑤	Quantity
⑥	Gross Weight(Kg)
⑦	Carton No.
⑧	Rohs

1.15 Package Reliability Test Conditions

NO	ITEM	Condition	Characteristics
1	Drop Test	Initial value measured at standard test condition. Test Conditions : - Test height : 100cm - Test times and Directions : 10 times each in 14 directions Drop the product onto a 10mm thickness plywood	No electrical problem No mechanical damage

1.16 Module Position Guide

Ground & Shield CAN must not exist around Antenna area.

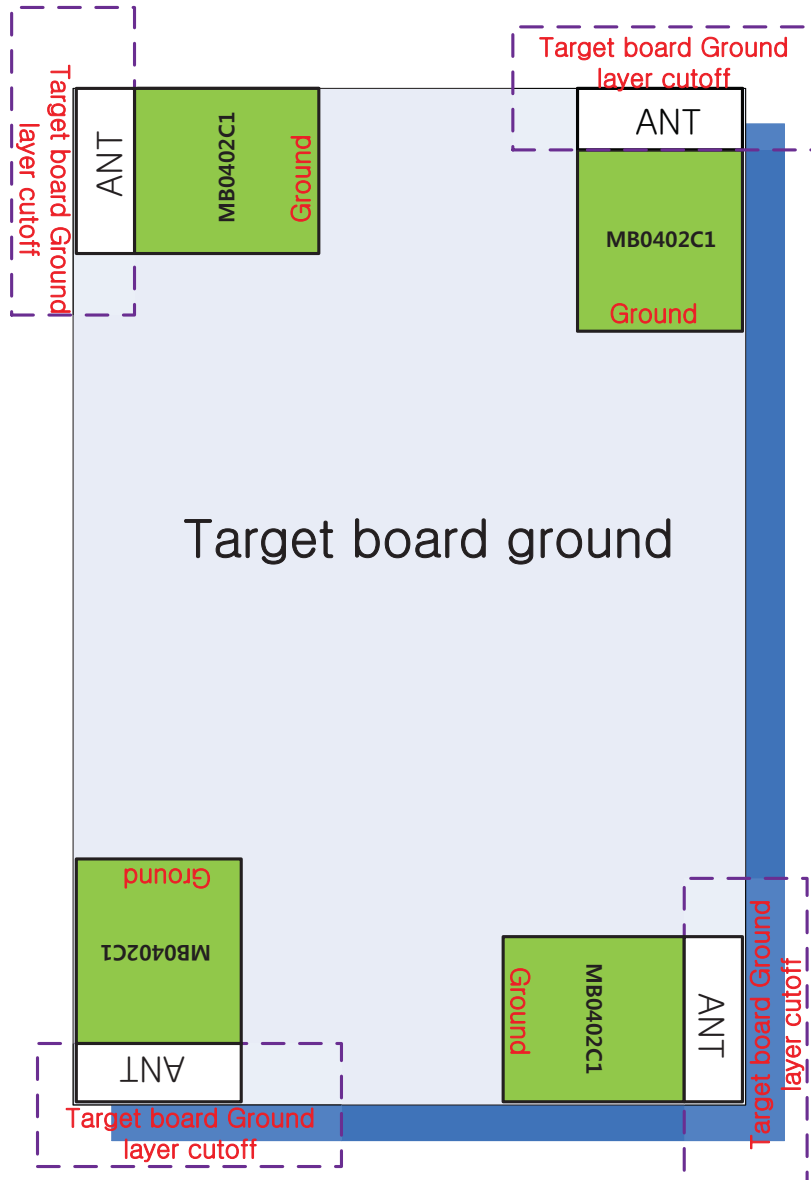

Approval Statements

CE approval

Hereby, we declare that this device is in compliance with the essential requirements and other relevant provisions of directive 1999/5/EC.

Restrictions of use: In France, this device must not be used outdoors.

FCC approval

This device complies with Part 15 of the FCC's Rules. Operation is subject to the following two Conditions:

1. This device may not cause harmful interference, and
2. This device must accept any interference received, including interference that may cause undesirable operation.

To satisfy FCC exterior labeling requirements, the following text must be placed on the exterior of the end product.

Contains Transmitter module FCC ID: BEJ9QK-MB0402C2

This equipment has been tested and found to comply with the limits for a Class B digital device, pursuant to part 15 of the FCC Rules. These limits are designed to provide reasonable protection against harmful interference in a residential installation. This equipment generates, uses and can radiate radio frequency energy and, if not installed and used in accordance with the instructions, may cause harmful interference to radio communications. However, there is no guarantee that interference will not occur in a particular installation. If this equipment does cause harmful interference to radio or television reception, which can be determined by turning the equipment off and on, the user is encouraged to try to correct the interference by one or more of the following measures:

Reorient or relocate the receiving antenna.

Increase the separation between the equipment and receiver.

Connect the equipment into an outlet on a circuit different from that to which the receiver is connected.

Consult the dealer or an experienced radio/ TV technician for help.

IC approval

This device complies with Industry Canada license-exempt RSS standard(s). Operation is subject to the following two conditions: (1) this device may not cause interference, and (2) this device must accept any interference, including interference that may cause undesired operation of the device.

Cet appareil est conforme avec Industrie Canada exempts de licence standard RSS (s). L'opération est soumise aux deux conditions suivantes: (1) cet appareil ne peut causer d'interférences, et (2) cet appareil doit accepter toute interférence, y compris les interférences qui peuvent causer un mauvais fonctionnement de l'appareil.

The host device must be labeled to display the Industry Canada certification number of the module.

Contains transmitter module IC: 2703H-MB0402C2

Le dispositif d'accueil doivent être étiquetés pour afficher le numéro de certification d'Industrie Canada du module.

Contient module émetteur IC : 2703H-MB0402C2

User information

Caution: Any changed or modifications not expressly approved by the party responsible for compliance could void the user's authority to operate this equipment.

Attention: Toute changé ou modifications non expressément approuvés par la partie responsable de la conformité pourraient annuler l'utilisateur `autorité de faire fonctionner cet équipement.

IMPORTANT NOTE

This device complies with FCC & IC radiation exposure limits set forth for an uncontrolled environment. This device should be installed and must not be co-located or operating in conjunction with any other antenna or transmitter.

This device is intended only for OEM integrators under the following conditions:

- 1) This module may not be co-located with any other transmitters or antennas.

As long as 2 conditions above are met, further transmitter test will not be required. However, the OEM integrator is still responsible for testing their end-product for any additional compliance requirements with this module installed.

In the event that these conditions cannot be met, then the FCC & IC authorizations are no longer considered valid and the FCC ID cannot be used on the final product. In these circumstances, the OEM integrator will be responsible for re-evaluating the end product including this module and obtaining separate FCC & IC authorizations.

NOTE IMPORTANTE

Cet appareil est conforme aux limites de la FCC et IC exposition aux radiations dans un environnement non contrôlé. Cet appareil doit être installé et ne doit pas être co-localisées ou opérant en conjonction avec une autre antenne ou un autre émetteur.

Cet appareil est conçu uniquement pour les intégrateurs OEM dans les conditions suivantes :

- 1) Ce module ne peut pas être co-localisés avec les autres émetteurs ou les antennes.

Aussi longtemps que deux conditions précitées sont remplies, le test du transmetteur supplémentaires ne seront pas tenus. Toutefois, l'intégrateur OEM est toujours responsable de tester leurs produits finis pour toutes les exigences de conformité supplémentaires avec ce module installé.

Dans le cas où ces conditions ne peuvent pas être remplies, alors la FCC et IC autorisations ne sont plus considérés comme valides et l'ID de la FCC ne peut pas être utilisé sur le produit final. Dans ces circonstances, l'intégrateur OEM sera responsable de réévaluer le produit final, y compris l'obtention de ce module et séparée de la FCC et IC autorisations

Label and manual requirements for the End Product

For an end product using the MB0402C2 there must be a label containing, at least, the following information:

For FCC ID

This device contains FCC ID : BEJ9QK-MB0402C2
--

For IC Certification No

This device contains IC ID : 2703H-MB0402C2
--