



GPRS Phone

USER'S MANUAL

MODEL: G1500

Please read this manual carefully
before operating your set.
Retain it for future reference.

G1500 has a polished style which provides users' a better feel and convenience.



G1500 Phone

Important Information

This user guide contains important information on the use and operation of this phone. Please read all the information carefully for optimal performance and to prevent any damage to, or misuse of, the phone. Any changes or modifications not expressly approved in this user guide could void your warranty for this equipment.

Before You Start

Safety Instructions

WARNING! To reduce the possibility of electric shock, do not expose your phone to high humidity areas, such as the bathroom, swimming pool, etc.

Always store your phone away from heat. Never store your phone in settings that may expose it to temperatures less than 32°F or greater than 104°F, such as outside during a snowstorm or in your car on a hot day. Exposure to excessive cold or heat will result in malfunction, damage and/or catastrophic failure.

Be careful when using your phone near other electronic devices. RF emissions from your mobile phone may affect nearby inadequately shielded electronic equipment. You should consult with manufacturers of any personal medical devices such as pacemakers and hearing aids to determine if they are susceptible to interference from your mobile phone. Turn off your phone in a medical facility or at a gas station. Never place your phone in a microwave oven as this will cause the battery to explode.

IMPORTANT! Please read the TIA SAFETY INFORMATION on page 95 before using your phone.

Safety Information

Please read and observe the following information for the safe and proper use of your phone and to prevent any unanticipated damage. Also, keep the user's manual in an accessible place at all the times after reading it.

- Unplug the power cord and charger during a lightning storm to avoid electric shock or fire.
- Do not use your phone in high explosive areas as the phone may generate sparks.
- Do not put your phone in a place subject to excessive dust, and keep the minimum required distance between the power cord and heat sources.
- Unplug the power cord prior to cleaning your phone, and clean the power plug pin when it is dirty.
- Do not damage the power cord by bending, twisting, pulling, or subjecting it to heat. Do not use the plug if it is loose as it may cause fire or electric shock.
- Hold the power cord plug firmly to plug and unplug the power cord. Ensure the plug is firmly connected. If it is not firmly connected, it may cause excessive heat or fire.
- Do not place a heavy item on the power cord. Do not allow the power cord to be crimped as it may cause fire or electric shock.
- Be careful not to let the battery contact metal conductors such as a necklace or coins. When shorted, it may cause an explosion.
- Do not disassemble or impact the battery as it may cause electric shock, short-circuit, and fire. Store the battery in a place out of reach of children.
- Using a damaged battery or placing a battery in your mouth may cause serious injury.

For Your Safety

- Do not place items containing magnetic components such as a credit card, phone card, bank book or a subway ticket, near your phone. The magnetic strip can be damaged by the phone.
- Do not hold or let the antenna come in contact with your body during a call.
- Talking on your phone for a long period of time may reduce the call quality due to heat generated during the use of the phone.
- Do not allow excessive vibration or impact to the phone.
- When you do not plan to use the phone for a long period of time, store it in a safe area with the power cord unplugged.

FCC RF Exposure Information

WARNING! Read this information before operating the phone. In August 1996, the Federal Communications (FCC) of the United States, with its action in Report and Order FCC 96-326, adopted an updated safety standard for human exposure to radio frequency (RF) electromagnetic energy emitted by FCC regulated transmitters. Those guidelines are consistent with the safety standard previously set by both U.S. and international standards bodies.

The design of this phone complies with the FCC guidelines and these international standards.

CAUTION

Use only the supplied and approved antenna. Use of unauthorized antennas or modifications could impair call quality, damage the phone, void your warranty and/or result in violation of FCC regulations. Do not use the phone with a damaged antenna. If a damaged antenna comes into contact with skin, a minor burn may result. Contact your local dealer for a replacement of antenna.

Body-worn Operation

This device was tested for typical body-worn operations with the back of the phone kept 0.59 inches (1.5 cm) from the body. To maintain compliance with FCC RF exposure requirements, use only belt-clips, holsters or similar accessories that maintain a 0.59 inch (1.5 cm) separation distance between the user's body and the back of the phone, including the antenna. The use of belt-clips, holsters and similar accessories should not contain metallic components in its assembly. The use of accessories that do not satisfy these requirements may not comply with FCC RF exposure requirements, and should be avoided.

Vehicle Mounted External Antenna (optional, if available)

A minimum separation distance of 8 inches (20 cm) must be maintained between the user/bystander and the vehicle mounted external antenna to satisfy FCC RF exposure requirements. For more information about RF exposure, visit the FCC website at www.fcc.gov

FCC Part 15 Class B Compliance

This device and its accessories comply with part 15 of FCC rules. Operation is subject to the following two conditions: (1) This device and its accessories may not cause harmful interference, and (2) this device and its accessories must accept any interference received, including interference that may cause undesired operation.

Cautions for Battery

- Do not disassemble.
- Do not short-circuit.
- Do not expose to high temperature: 60°C (140°F).
- Do not incinerate.

For Your Safety

Battery Disposal

- Please dispose of your battery properly or bring to your local wireless carrier for recycling.
- Do not dispose in fire or with hazardous or flammable materials.

Adapter (Charger) Cautions

- Using the wrong battery charger could damage your phone and void your warranty.
- The adapter or battery charger is intended for indoor use only.

Do not expose the adapter or battery charger to direct sunlight or use it in places with high humidity, such as the bathroom.

Contents

Overview

Part of the Phone	13
• Front of the Phone	13
• Rear of the Phone	14
Key Description	15
• Alphanumeric Keys	17

Display Information

Display Information	18
• On-Screen Icons	18

Getting Started

Installation	20
• Inserting the SIM Card	20
• Installing the Battery	20
• Charging the Battery	21
• Disconnecting the charger	22
Powering On Sequence	23
• To get started with the phone	23
• To turn off the phone	23
Access Codes	24
• PIN code (4 to 8 digits)	24
• PIN2 code (4 to 8 digits)	24
• PUK code (4 to 8 digits)	24
• PUK2 code (4 to 8 digits)	25
• Security code (4 to 8 digits)	25

Accessing the Menu

Phonebook	26
• Search [Names 1]	27
• Add new [Names 2]	28
• Speed dial [Names 3]	29
• Voice list [Names 4]	30
• Caller groups [Names 5]	30
• Copy all [Names 6]	32
• Delete all [Names 7]	32
• Settings [Names 8]	33
• Information [Names 9]	34
Menu Tree	36
Messages [Menu 1]	38
• Write message [Menu 1-1]	38
• Inbox [Menu 1-2]	43
• Outbox [Menu 1-3]	44
• Info Service [Menu 1-4]	45
• Voice messages [Menu 1-5]	47
• Namecard [Menu 1-6]	48
• Templates [Menu 1-7]	48
• Settings [Menu 1-8]	48
• Check memory [Menu 1-9]	49
Call Register [Menu 2]	50
• Missed calls [Menu 2-1]	50
• Received calls [Menu 2-2]	50
• Dialed calls [Menu 2-3]	50
• Clear recent calls [Menu 2-4]	50
• Call charge [Menu 2-5]	51
• GPRS information [Menu 2-6]	53

Profiles [Menu 3]	54
• Vibrate only [Menu 3-1]	54
• Quiet [Menu 3-2]	54
• General [Menu 3-3]	55
• Loud [Menu 3-4]	55
• Headset [Menu 3-5]	55
• Car [Menu 3-6]	55
Settings [Menu 4]	58
• Alarm clock [Menu 4-1]	58
• Date & Time [Menu 4-2]	59
• Phone settings [Menu 4-3]	60
• Call settings [Menu 4-4]	61
• Security settings [Menu 4-5]	65
• Network settings [Menu 4-6]	69
• Restore factory settings [Menu 4-7]	69
Call Divert [Menu 5]	70
• All voice calls [Menu 5-1]	70
• If busy [Menu 5-2]	70
• If no reply [Menu 5-3]	70
• If unreachable [Menu 5-4]	70
• All data calls [Menu 5-5]	70
• All fax calls [Menu 5-6]	70
• Cancel all [Menu 5-7]	71
Scheduler [Menu 6]	72
• Add new [Menu 6-1]	73
• View day [Menu 6-2]	74
• View all [Menu 6-3]	74
• Delete passed [Menu 6-4]	74
• Delete all [Menu 6-5]	74

Fun & Tools [Menu 7]	75
• Game [Menu 7-1].....	75
• Unit convert [Menu 7-2].....	76
• Calculator [Menu 7-3].....	76
• World time [Menu 7-4].....	77
Internet [Menu 8]	78
• Home [Menu 8-1]	78
• Bookmarks [Menu 8-2]	78
• Profiles [Menu 8-3]	78
• Go to URL [Menu 8-4]	81
• Cache settings [Menu 8-5]	81
• Security certifications [Menu 8-6].....	82
• Reset profiles [Menu 8-7]	82
Internet On-line menu	83

Additional Functions

How to Use Data and Fax call	84
• Sending Data or Fax Calls	84
• Receiving Data or Fax Calls	84
In call Menu	86
• 1 During a call	86
• 2 Multiparty or Conference Calls	89
Accessories	92
Safety Guidelines	94
Technical Data	109

Front of the Phone

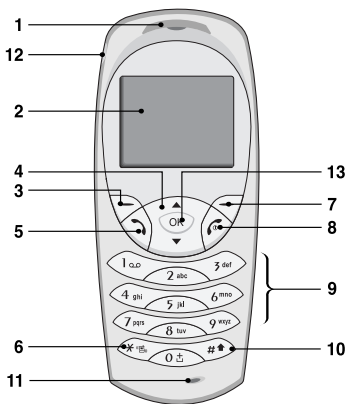

- | | |
|-------------------|-----------------------------|
| 1 Earpiece | 8 END/PWR keys |
| 2 Display Screen | 9 Numeric Keys |
| 3 Soft Left Key | 10 Hash Key |
| 4 Navigation Keys | 11 Microphone |
| 5 Send Key | 12 Ear Microphone Connector |
| 6 Star Key | 13 Confirm Key |
| 7 Soft Right Key | |



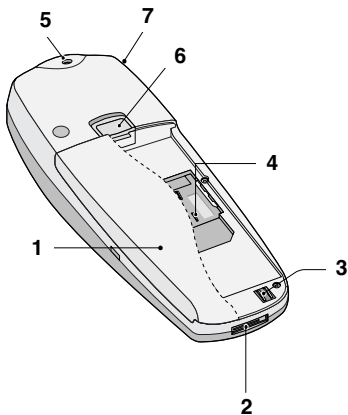







Rear of the Phone



- 1 Battery**
- 2 Cable Connector/
Battery Charging Connector/
Hands-Free Car kit Connector**
- 3 Battery Terminals**
- 4 SIM Card Socket**
- 5 Handstrap Hole**
- 6 Battery Lock**
- 7 Ear Microphone Connector**



The following shows key components of the phone.

Keypad Description

Key	Description
	<p>Soft Left Key / Soft Right Key Each of these keys performs the function indicated by the text on the display immediately above it.</p>
	<p>WAP Hotkey Used to connect to WAP directly by pressing this key. Used to delete character(s).</p> <p>Navigation Keys Used to scroll through name, phone numbers, menus or setting options.</p>
	Used to enter Message menu directly.
	Used to scroll through names, phone numbers.
	<p>Send Key You can dial a phone number and answer a call. If you press this key without entering a number, your phone shows the most recently dialed number.</p>
	<p>Numeric Keys These keys are used mainly to dial in standby mode and enter numbers or characters in editing mode. When you press these keys for a long time.</p> <ul style="list-style-type: none"> Used to call your voicemail box by . Used to call for international call by . Used to call Speed dials by from  to .







Key Description

Overview

Key	Description
	Used to enter the vibration mode by pressing this key for a long time
	Used to call by voice dial with long pressing this key. This key is also used as Ear mic. hook key when connecting Ear mic.
	END/PWR Key Used to end or reject a call. This key is also used as Power Key. Pressing and holding this key for a few seconds.

Alphanumeric Keys

The alphabet and numerical keypad mapping relation are listed as the following table.















Key	Description
	. , ' ? ! - & 1
	A B C 2 Ä Å Ã Ä Æ Ç a b c ä å á â ã æ ç
	D E F 3 È É Ê Ë def è é ê ë
	G H I 4 Î Ï Ì Í g h i î ï ì í
	J K L 5 j k l
	M N O 6 Ö Õ Ò Ó Ø Ñ m n o ö õ ò ó ø ñ
	P Q R S 7 p q r s
	T U V 8 Ü Û Û Ú t u v ü ù ú
	W X Y Z 9 w x y z
	0 [Space Key]



Display Information

Display Information









The screen displays several icons the following describe each of them you may see on the phone.

On-Screen Icons

Icon/Indicator	Description
	Tells you the strength of the network signal.
	Call is connected.
	Line 1/2 is in use for outgoing calls—If you subscribe to the Two Line Service.
	The alarm has been set and is on.
	Tells you the status of the battery.
	You have received a text message.
	You have received a voice message depending on your subscription.
	You have received an E-mail.
	You can view your schedule.
	All audible signals are turned off.
	General menu in profiles.
	Loud menu in profiles.
	Quiet menu in profiles.
	You can use GPRS service.

Icon/Indicator	Description
	Headset menu in profiles.
	Handsfree menu in profiles.
	You can divert a call.

Top Menu Icons

Icon	Description
¹ 	Messages
² 	Call register
³ 	Profiles
⁴ 	Settings
⁵ 	Call divert
⁶ 	Scheduler
⁷ 	Fun & Tools
⁸ 	Internet
⁹ 	Sim service

1 Inserting the SIM Card

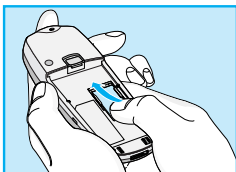

Locate the SIM card socket in the back of the phone.

Follow the steps below to install the SIM card.

1. Remove the battery if attached.
2. Slide the SIM card into the slot, under the silvery holders, with the golden connectors facing down and the cut corner to the right.

! Notice

- Before installing always make sure that the phone is switched off and remove the battery.
- The metal contact of the SIM card can be easily damaged by scratches. Pay special attention to the SIM card when you handle and install. Follow the instructions supplied with the SIM card.

2 Installing the Battery

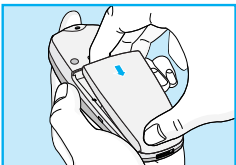

1. Place the battery on the back of the phone.

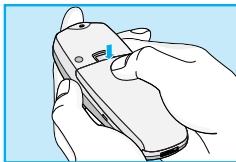

2. Push it until you hear a click.

3 Charging the Battery

To connect the travel adapter to the phone, you must have installed the battery.

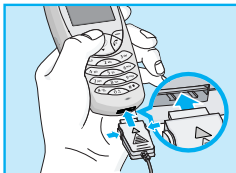

1. Insert one end of the travel adapter into the bottom of the phone.

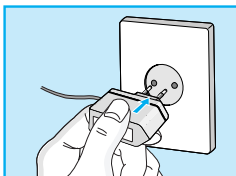

2. Connect the other end of the travel adapter to an AC wall outlet.
Use only the included packing charger.



! Warning

- Do not force the connector as this may damage the phone and/or the travel adapter.

4 Disconnecting the charger

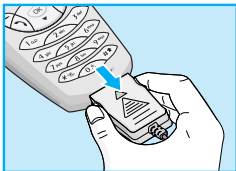



Disconnect the travel adapter from the phone by pressing its side buttons.

! Notice

- The battery delivered with your phone has to be fully charged before using it.
- Do not remove your battery or the SIM card while charging.
- “Battery Charging” is displayed on the screen after connecting the travel adapter. Only if the battery is totally empty, Back light is on without displaying “Battery Charging”.
- The moving bars of battery icon will stop after charging completely.

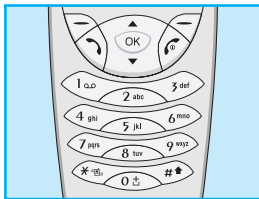
1 To get started with the phone



1. Press and hold  key until you hear a tone.
2. Depending on setting **PIN Code** [Menu 4-5-1], you can enter PIN code or not.
3. If your phone connects to a network, the network name will be displayed shortly.

2 To turn off the phone

In stand by mode, press and hold  key until you hear a tone.

You can use the access codes described in this section to avoid unauthorized use of your phone. The access codes (except PUK and PUK2 codes) can be changed by using [Menu 4-5-6].

[PIN code \(4 to 8 digits\)](#)

The PIN (Personal Identification Number) code protects your SIM card against unauthorized use. The PIN code is usually supplied with the SIM card. When **PIN code** is set **Enable**, your phone will request the PIN code every time it is switched on. On the contrary, when **PIN code** is set **Disable**, your phone connects to the network directly without the request PIN code.

[PIN2 code \(4 to 8 digits\)](#)

The PIN2 code, supplied with some SIM cards, is required to access some functions such as Advice of call charge, Fixed Dial number. These functions are only available if supported by your SIM card.

[PUK code \(4 to 8 digits\)](#)

The PUK(Personal Unblocking Key) code is required to change a blocked PIN code. The PUK code may be supplied with the SIM card. If not, contact your local service provider for the code. If you lose the code, also contact your service provider.

PUK2 code (4 to 8 digits)

The PUK2 code, supplied with some SIM cards, is required to change a blocked PIN2 code. If you lose the code, also contact your service provider.

Security code (4 to 8 digits)



The security code protects the unauthorized use of your phone. It is usually supplied with the phone. This code is required to delete all phone entries and to activate “Factory reset” menu. The default number of Security code is “0000”. You can also change it in Security menu.

Phonebook

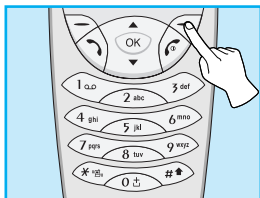
Accessing the Menu









To select a menu in phonebook, press  [Names] in standby mode and then scroll to a desired item.

	Name	Description
1	Search	Allows you to search for a specific name, number.
2	Add new	Allows you to add new names and numbers.
3	Speed dial	Allows you to assign up to 8 ( - ) one-touch dial allocations.
4	Voice list	Allows you to list phone numbers which is attached voice.
5	Caller groups	Allows you to show group list.
6	Copy all	Allows you to copy entries from your Phone memory to SIM card or from SIM card to Phone memory.
7	Delete all	Allows you to erase all the data in either your phonebook or the SIM card to the phone memory.
8	Settings	Allows you to set the memory and to search item by Variable, name and number.
9	Information	Allows you to check the status of memory, SDN (Service Dial Number), and Own number.

Search [Names 1]

(Calling from phonebook)









1. Open the phonebook first by pressing  [Names] in a standby mode.
2. **Search** by Pressing  [Select] to enter.
3. Depending on setting **Search by**, the below menu may not appear.
 - **Name**
 - **Number**
4. You can find an entry by name and number.
5. Select  [Search].
6. You can check the names and numbers by pressing  [List].
7. If you want to edit, delete, copy an entry, or to add the voice to one, select  [Options]. The below menu will be displayed.
 - **Edit** : You can edit the name, number, E-mail, and fax by pressing  [OK].
 - **Delete** : You can delete an entry.
 - **Copy** : You can copy a entry from SIM to phone or from phone to SIM.
 - **Call** : You can call thru the chosen entry.
 - **Voice** : You can add the voice to the entry or change the voice tag.
 - **Main number** : You can select the one out of mobile, home, office that you often use. The main number will be displayed first, if you set this.

Add new [Names 2]

You can add phonebook entry by using this function.

Phone memory capacity is 200 entries. SIM card memory capacity depends on the service provider.

You can also save 20 characters of name in the Phone memory, and you can save characters in the SIM card. the number of character is SIM dependent feature.

1. Open the phonebook first by pressing  [Names] in standby mode.
2. Scroll to highlight **Add new**, and press  [Select] to enter.
3. Select the memory you want to save: **SIM** or **Phone**.
 - **SIM** : You can add name and number for entry.
 - a. Write a name to add.
 - b. Press  [OK], then you can input a number.
 - c. Press  [OK].
 - d. If you want to add the voice, press  [Yes].
 - **Phone** : You can add name, mobile, home, office, fax no. and E-mail address.
 - a. Write a name to add.
 - b. Press  [OK].
 - c. Enter the numbers following as mobile, home, office, and fax by pressing  [OK]. Also you can input E-mail address.
 - d. If you want to add the voice, press  [Yes].



You should speak a word within 2 seconds, and the phone asks you to speak it again to ensure the accuracy of voice recognition. After voice recognition has finished, Voice is attached automatically.

Note

- The voice can only be attached to main number which you set. For example, If you change main number voice will be automatically attached changed number.
- You can add voice tag to phone number in SIM card. The voice tag can be erased removing or changing SIM card. And voice tag attached to phone number in SIM card may be attached to another phone number when you changed SIM card. Why? The answer is that SIM card doesn't contain information about voice tag.





Speed dial [Names 3]

You can associate any of the keys 2 to 9 with a Name list entry. You can call directly by pressing this key for 2-3 seconds.

1. Open the phonebook first by pressing  [Names] in a standby mode.
2. Scroll to **Speed dial**, then press  [Select] to enter this menu.
3. Every Speed dial will be displayed.
4. If you want to add Speed dial, select <Is Empty>. Then, you can search the name in phonebook.

5. If you select allocated name by speed dial, you can view following the submenus.
- **Change** : You can change the allocation of speed dial number.
 - **Undo speed dial** : You can delete the allocated speed dial number.



Voice list [Names 4]

You can see all phone numbers which contain voice. You can also call directly by pressing  [Send]. After selecting phone number by using  and  and press  [Options], you can see following the submenus.

- **Play** : You can play voice which is attached to phone number.
- **Change** : You can change voice which is attached to phone number.
- **Delete** : You can delete voice which is attached to phone number.
- **Call** : You can call by selecting this menu.

Caller groups [Names 5]

You can list up to 20 members per one group. There are 7 groups you can make lists to.

1. Press  [Names] to enter into the phonebook in standby mode.
2. Scroll to **Caller groups** then press  [Select] to enter this menu.

3. Every Group list will be displayed: **Family, Friend, Colleague, VIP**, etc.
4. Select Group name that you want to manage by pressing  [Select].
5. Then submenus below will be displayed.

- **Add member**

You can add the number in Caller groups.

- **View member**

- You can view the number list in Caller groups.
- You can select the member you want by pressing  [Options] then you can enable the submenu such as **Edit, Delete**.

- **Group ring tone**

- You can set the ring tone depending on Group.

- **Group icon**

- You can set icon depending on Group.

- **Change name**



- You can change and edit the Group name.

 **Note**

- This menu “**Change name**” will be displayed only when you select “**Empty**”.





Copy all [Names 6]

You can copy/move entries from SIM card memory to Phone memory or from Phone memory to SIM card memory.

1. Open the phonebook first by pressing  [Names] in standby mode.
2. Scroll to **Copy all**, then press  [Select] to enter this menu.
3. Then submenus below will be displayed.
 - **SIM to Phone** : You can copy the entry from SIM Card to Phone memory.
 - **Phone to SIM** : You can copy the entry from Phone memory to SIM Card.



Delete all [Names 7]

You can delete all entries in **SIM**, **Phone** and **Voice**. This function requires security code.

1. Press  [Names] to enter into the phonebook in standby mode.
2. Scroll to **Delete all**, then press  [Select].
3. Then select a memory to erase: SIM, Phone, Voice.
4. And then you will be requested to enter Security code.
5. Press  [OK] or, press  [Back] to cancel.

Settings [Names 8]

You can set preferred memory which includes **Variable, SIM or Phone** and preferred search which includes **Variable, Name and Number**.

1. Open the phonebook first by pressing  [Names] in a standby mode.
2. Scroll to **Settings**, then Press  [Select] to enter.
3. Then submenus below will be displayed.

• Set memory

1. Scroll to highlight **Set memory**, then press  [Select] to enter.
2. The three submenus are displayed.
 - **Variable** : If you select Variable, the phone asks you where to store whenever you add entries in Phonebook.
 - **SIM** : If you select SIM, the phone stores entries to SIM directly without asking you where to store.
 - **Phone** : If you select Phone, the phone stores entries to Phone directly without asking you where to store.





• Search by

1. Scroll to highlight Search by, then press  [Select] to enter.
2. The three submenus are displayed.
 - **Variable** : If you select Variable, the phone asks you how to search the entries.
 - **Name** : If you select Name, the phone searches entries by name.
 - **Number** : If you select Number, the phone searches entries by number.

Information [Names 9]

SDN (Service Dial Number)



Use this function to access a particular list of services provided by your network operator (if supported by the SIM card).

1. Open the phonebook first by pressing  [Names] in a standby mode.
2. Scroll to **SDN**, then Press  [select] to enter.
3. The names of the available services will be shown.
4. Use  and  to select a service. Press  [Send].

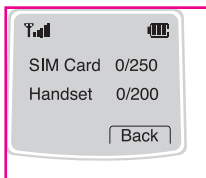
Check memory



This feature allows you to see how many free and in-use are in your phonebook.

1. Open the phonebook first by pressing  [Names] in standby mode. Select **Information** by pressing  [Select].
2. Scroll to **Check memory**, then press  [Select] to enter this menu.

Own number (SIM dependent)

You can check your own number in SIM card.



1 Messages

- 1 Write message
- 2 Inbox
- 3 Outbox
- 4 Info service
- 5 Voice messages
- 6 Namecard
- 7 Templates
- 8 Settings
- 9 Check memory



2 Call Register

- 1 Missed calls
- 2 Received calls
- 3 Dialed calls
- 4 Clear recent calls
- 5 Call charge
- 6 GPRS information



3 Profiles

- 1 Vibrate only
- 2 Quiet
- 3 General
- 4 Loud
- 5 Headset
- 6 Car



4 Settings

- 1 Alarm clock
- 2 Date & Time
- 3 Phone settings
- 4 Call settings
- 5 Security settings
- 6 Network settings
- 7 Restore factory settings



5 Call Divert

- 1 All voice calls
- 2 If busy
- 3 If no reply
- 4 If unreachable
- 5 All data calls
- 6 All fax calls
- 7 Cancel all



6 Scheduler

- 1 Add new
- 2 View day
- 3 View all
- 4 Delete passed
- 5 Delete all



7 Fun & Tools

- 1 Game
- 2 Unit convert
- 3 Calculator
- 4 World time



8 Internet

- 1 Home
- 2 Bookmarks
- 3 Profiles
- 4 Go to URL
- 5 Cache settings
- 6 Security certifications
- 7 Reset profiles





9 Sim Service

This menu depends on SIM and the network services.

This menu includes functions related to SMS (Short Message Service), voice mail, as well as the network's service messages.



Write message [Menu 1-1]

You can write and edit text message up to 1024 characters. Also, you can check the number of characters.

1. Enter the **Messages** menu by pressing  [Select].
2. If you want to write a new message, select **Write message** in the menu.
3. Input the message by using eZi text. For details, see eZi text (Page 39).
4. When you finish writing your message, press  [Options]. Then following option menu will be displayed.



Send

Sends the text message.

1. If you want to send the text message, enter the number you want.
2. Your phone asks you to enter the number that you want to send it to.
3. After sending it, your phone asks whether you will store the edited message.
4. Press  if you want to store it in Outbox and press  if you don't want to.

Save

Stores the message in Outbox.

1. Your phone asks whether you will save the edited message.
2. Press  if you want to save it in Outbox and press  if you don't want to.

Use template



The template is pre-defined message. You can add the template of the list to the message when you edit it.

Use namecard

The items of the name card are a name, mobile, office, and memo. You can add a namecard to the message.



Add dictionary

If you add a word you use often, you can input it by pressing a key once for each character.

1. Enter the menu.
2. Scroll to highlight **Add dictionary**, and then press  [Select].
3. Input a word, and then press  [Add].

List dictionary

You can view the list you already saved words in a dictionary.

1. Enter the menu.
2. Scroll to highlight List dictionary, and then press  [Select].
3. You can check the word list.
4. If you want to delete a word, press  [Delete].
5. If you want to delete all words in a list, select **Delete all** at the bottom of the list by pressing  [Select].

eZi-Text

The eZi text allows you to type easily and quickly. If you just press a key marked a character on the keypad, you can get a character you want. It is useful to make a word and a sentence. If you press key for a long time, you can change the type of language.

Also, the phone supports four modes: **eZi Mode**, **Numeric mode**, **Capital mode**, and **Small mode**. If you want to change mode, press key.

• How to Use in eZi mode

To input a character in eZi text mode, you just press each key once for a character you want.

For example, to write **Girl** in eZi mode;

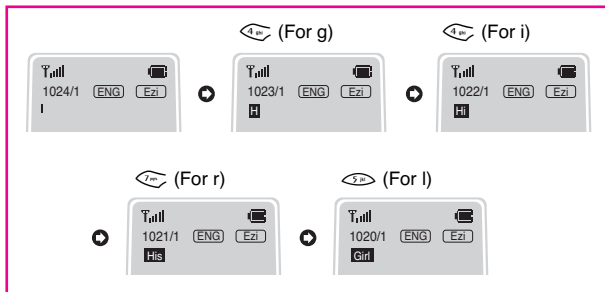

• How to use in Numeric mode

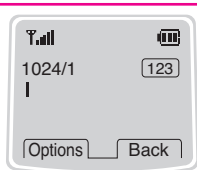

To input a number in Numeric mode, you press a number key displayed on the keypad.

• How to use in Capital mode

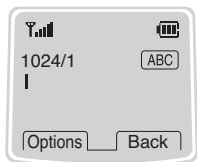

To input Capital letter, you press a character key displayed on the keypad.

• How to use in Small mode

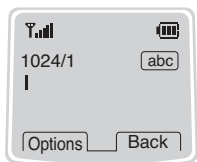



To input Small letter, you press a character key displayed on the keypad.

! Note

- If you want to input a symbolic character, press  key in each mode.

Inbox [Menu 1-2]

When you receive a text message, your phone shows the symbol and stores it in the incoming message lists. Scroll to the desired message by using  , . In addition, you can see Delete all for deleting all incoming messages at the bottom of the list. While reading the message, press  [Options] to access the available options.

Delete

The selected message is deleted.

Edit

You can edit an incoming message and send or save the edited message.

Forward

You can forward the selected message to the other party.

Get number

If the selected message has the phone number, you can extract and save it in a phonebook. Also, you can call by this number.





Reply

You can reply to the sender by message.

Return call

You can call back to the sender who sent the message automatically.

Outbox [Menu 1-3]

When you enter this menu, you can see the message(s). Scroll to the desired message by using ,  and press  to see the message. And if you want to exit **Outbox** menu, press .

And if you want to exit outbox menu, press . In addition, you can see **Delete all** for deleting all outgoing messages at the bottom of the list.

After reading message, press  [Options] to access the following submenus.

Delete

The selected message is deleted.

Edit

You can edit an outgoing message and send or save it.

Forward

You can forward the selected message to the other party.



Get number

If the selected message has the phone number, you can extract and save it in a phonebook. Also, you can call by this number.

Info Service [Menu 1-4] (Dependent to network and subscription)

Cell Broadcast messages (CB Message) are text messages by the network to GSM phone users. They provide general information such as weather reports, traffic news, taxis, pharmacies, and stock prices. Each type of information has the number; therefore, you can contact service provider. When you receive CB message, you can read it following sequence:

Read [Menu 1-4-1]

1. When you receive CB message, it will be displayed on the screen. You can read the message by scrolling  , .
2. After reading the message, press  to return to the standby mode. In addition, you can save it until another message is reached.

Receive CB [Menu 1-4-2]

• Yes

If you select this menu, your phone will receive the Cell Broadcast message.

• No

If you select this menu, your phone will not receive the Cell Broadcast message any more.

Alert [Menu 1-4-3]

- **Yes**

If you select this menu, your phone will beep when Cell broadcast message is received.

- **No**

If you select this menu, your phone will not beep despite Cell broadcast message is received.

Language [Menu 1-4-4]

You can select the language you want. Then your phone will receive the cell broadcast message in the language selected by you.

You can select Cell broadcast language pressing  [Select]. The language list which you selected already will be displayed with check box.

Topics(Dependent to network and subscription) [Menu 1-4-5]

- **Add [Menu 1-4-5-1]**

If you select this menu, you will add the CB message category in Phone memory.

- **View list [Menu 1-4-5-2]**

If you select this menu, you can see CB message category. If you press  [Options], you can edit and delete it.

- **Active list [Menu 1-4-5-3]**

You can select the CB message category in active list by pressing  [Select].

Voice messages [Menu 1-5]

You can listen to your voice message(s) and get the voicemail centre number.

Listen to voice message [Menu 1-5-1]

You can call voicemail centre if you want to listen to voice message.

Voice mailbox number [Menu 1-5-2]

You can get the voicemail if this feature is supported by the network service provider. When new voicemail is arrived, the symbol will be displayed on the screen. Please check with your network service provider for details of their service in order to configure the handset accordingly.

1. Press  key for a long time in standby mode.
2. You can check the following submenus.

• Home [Menu 1-5-2-1]

The number dialed on the home network to listen to voicemail.

• Roam [Menu 1-5-2-2]

The number dialed when other networks to listen to voicemail.

Namecard [Menu 1-6]

It's for editing the namecard. The items of the namecard are a name, mobile, office, and memo.

- **Edit** : You can edit a namecard.
- **Delete** : You can delete a namecard.

Templates [Menu 1-7]

It's for editing pre-defined messages. You can see 11 pre-defined messages in the list. You can save 6 templates before you edit. But you can change them. The others are <Empty>.

- **Edit** : You can edit a template.
- **Delete** : You can delete the template.

Settings [Menu 1-8]

Message type [Menu 1-8-1]

Text, Voice, Fax, Natl. paging, X.400, E-mail, ERMES

Usually, the type of message is set to **Text**. You can convert your text into alternative formats, which are suitable for the device that will be received the message. Contact your service provider for the availability of this function.

Validity period [Menu 1-8-2]

This network service allows you to set how long your text messages will be stored at the message center while attempts are made to deliver them to you.

Status report [Menu 1-8-3]

If you set **Yes** in this menu, you can check whether your message is sent successfully or not.

Pay for reply? [Menu 1-8-4]

When a message is sent, it allows the person to whom you sent the message to reply and charges the cost of the reply to your telephone bill.

SMS centre [Menu 1-8-5]

If you want to send the text message, you can get the address of SMS center thru this menu.

Check memory [Menu 1-9]

If you select this menu, the phone shows an used memory and total amount of memory. The total memory is the sum of SIM and Phone memory.

Call Register [Menu 2]

Accessing the Menu

Missed calls [Menu 2-1]

This menu shows recent missed call number(s). You can call by this number, save it or view date and time in this menu.

Received calls [Menu 2-2]







You can check the recent received numbers. You can call by this number, save it or view date and time in this menu.

Dialled calls [Menu 2-3]

You can check the recent dialled numbers. You can call by this number, save it or view date and time in this menu.

Clear recent calls [Menu 2-4]

You can delete all call records.





1. Press  [Menu] in standby mode.
2. Press  for direct access or use  and  to enter **Call register**.
3. Scroll to highlight **Clear recent calls** and press  [Select] to enter.
4. The following four submenus : Missed calls, Received calls, Dialled calls, All calls.
5. **Delete all** message will be displayed and then press  [Select], then, press one more time  [Yes] to confirm.

Call charge [Menu 2-5]

Within these submenus, you can view the duration and the call cost.

Call duration [Menu 2-5-1]





This function allows you to view the duration of your Last Call, All Calls, Incoming Calls and Outgoing Calls in hours, minutes and seconds. You can also reset the call timers.

1. Press  [Menu] in standby mode.
2. Press  for direct access or use  and  to enter **Call register**.
3. Scroll to highlight **Call duration** and press  [Select].

The following 5 submenus: **Last call, All calls, Received calls, Dialed calls** and **Reset all**.

Show call costs [Menu 2-5-2]

This function allows you to check the cost of your last call, all calls, remaining and reset the costs. To reset the cost, you need the PIN2 code.

1. Press  [Menu] in standby mode.
2. Press  for direct access or use  and  to enter **Call register**.
3. Scroll to highlight **Show call costs** and Press  [Select] to enter.

The following 4 submenus: **Last call, All calls, Remaining** and **Reset all**.





Note

- The actual call cost may be different depending on network features, billing, and tax.

Cost settings [Menu 2-5-3] [SIM Dependent]





• Set tariff [Menu 2-5-3-1]

You can set the currency type and the unit price. Contact your services providers to obtain charging unit prices. To select the currency or unit in this menu, you need the PIN2 code.

1. Press  [Menu] in standby mode.
2. Press  for direct access or Use  and  to enter **Call register**.
3. Scroll to highlight **Cost settings** and Press  [Select] to enter.
4. Select **Set tariff**.

• Set credit [Menu 2-5-3-2]

This network service allows you to limit the costs of your calls by selected charging units. If you select **Read**, the number of remaining unit is shown. If you select **Change**, you can change your charge limit.

1. Press  [Menu] in a standby mode.
2. Press  for direct access or use  and  to enter **Call register**.
3. Scroll to highlight **Cost settings** and press  [Select] to enter.
4. Select **Set credit**.

 **Note**

- When all units have been used, no calls can be made except emergency calls. Depending on SIM card, you need the PIN2 code to set a call cost limit.

GPRS information [Menu 2-6]

You can check the amount of data transferred over the network through GPRS. In addition, you can also view how much time you are online.

Call duration

You can check the duration of GPRS call. You can also reset the call timers.

- **Last call**
- **All calls**
- **Reset all**

Data volume





You can check the data volume.

- **Sent**
- **Received**
- **All**
- **Reset all**

Profiles [Menu 3]

Accessing the Menu

In this menu, you can adjust and customize the phone tones for different events, environments and caller's group. (e.g. When your phone is connected to the Handsfree kit, it'll be automatically set to the Car profiles menu and when your phone is connected to the Earmic, it'll be automatically set to Headset profiles menu.)

1. Press  [Menu] in standby mode.
2. Press  for direct access or use  and  to enter **Profiles**.

Note

- In case that your phone is connected to Accessories such as Earmic and Handsfree, you cannot enable Profiles menu manually.
- Profiles menu has “Enable” submenu except Headset and Car so that you can set Profiles menu at any time except above case.

Vibrate only [Menu 3-1]

- **Enable** : You can adjust the Profiles as Vibration if you need vibration mode.

Quiet [Menu 3-2]

- **Enable** : You can adjust the Profiles as Quiet if you are in Silent place.
- **Change** : You can change the values of Profiles submenus.

General [Menu 3-3]

- **Enable** : You can adjust the Profiles as General
- **Change** : You can change the values of Profiles submenus.

Loud [Menu 3-4]

- **Enable** : You can adjust the Profiles as Loud if you are in a noisy environment.
- **Change** : You can change the values of Profiles submenus.

Headset [Menu 3-5]

- **Enable** : You can adjust the Profiles as Headset when you put on a headset.
- **Change** : You can change the values of Profiles submenus.

Car [Menu 3-6]

- **Enable** : You can adjust the Profiles as Car when you activate Handsfree Kit.
- **Change** : You can change the values of Profiles submenus.

A Group of Profiles submenus [Menu 3-x-x]

Profiles menu have the submenus as shown below.

Incoming alert type [Menu 3-x-1]

Allows to set alert type for the incoming call for adjusting environment.

Ringing tone [Menu 3-x-2]

Allows to set the ringing tone for adjusting environment.

Ringing volume [Menu 3-x-3]

Allows to set the ringing volume for adjusting environment.

Message alert [Menu 3-x-4]

Allows to alert when receiving a message for adjusting environment.:

Beep, Vibrator, and No alert.

Key volume [Menu 3-x-5]

Allows to set the keypad volume for adjusting environment.

Automatic answer [Menu 3-x-6]

Allows to set to answer automatically for adjusting environment.

Please note that only Car and Headset has this sub menu so that you can activate this function.

- **Disable**

Even though your phone is ringing, your phone will not answer automatically.

- **After 5 sec**

After 5 seconds your phone will answer automatically.



- **After 10 sec**

After 10 seconds your phone will answer automatically.

Note

- If you set the Handsfree kit to the phone, you can't activate the vibration related with Incoming alert type or Message alert menu. Therefore, in Car menu, you can view the following submenus;
 - **Incoming alert** : Ring, Silent
 - **Message alert** : Beep, No alert

You can set the following menus for your convenience and preferences.



1. Press  [Menu] in standby mode.
2. Press  for direct access to enter Setting.

Alarm clock [Menu 4-1]

You can set the phone to alarm at a specified within this menu.



Enable [Menu 4-1-1]

You can set the time (Hour and Minute) for raising the alarm.

1. Enter the menu.
2. Select Enable by pressing  [Select], and then enter the alarm time you want.
3. Press  [OK].
4. Select the repeat period: **Once**, **Daily**, **Weekly**, and **Monthly**.
5. If you set in Power off alarm, the alarm signal sounds at the time you set even if the phone is turned off.

Disable [Menu 4-1-2]

You can cancel setting the alarm time.



1. Enter the menu.
2. Select **Disable** by pressing  [Select].
3. **Clear alarm** message will be displayed when the phone is set to alarm before.
4. If you want to cancel, press  [Yes]. If not, press  [No].

Date & Time [Menu 4-2]

Date [Menu 4-2-1]

• **Set date**

In this menu, you can set the date of your phone.

1. Enter the menu.
2. Select Set date by pressing  [Select].
3. Enter the number you want to set the date.
4. Press  [OK].

• **Date format**

You can set the Date format in this menu.





Time [Menu 4-2-2]

The phone has its own clock. In this menu you can set the time and select between the 12-hour or 24-hour time formats.

1. Enter the menu.
2. Scroll to highlight Time by pressing  [Select].



• **Set time:**

You can set time of your phone in this menu.

1. Select Set time by pressing  [Select].
2. Enter the number you want to set the time.
3. Select the **am/pm** you want to set the time format by long pressing  ,  key.
4. Press  [OK].

• Time format:

You can select time format between 12-hour or 24-hour.

1. Scroll to highlight Time format by pressing  [Select].
2. Select 12 hour or 24 hour you want by pressing  [Select].

Phone settings [Menu 4-3]

You can set the phone setting you want. Scroll to highlight **Phone settings** menu, and then press  [Select].

Display [Menu 4-3-1]

• Screen saver [Menu 4-3-1-1]

If you don't activate any function for 20 seconds, the picture will be displayed in a standby mode.

• Welcome note [Menu 4-3-1-2]



This menu allows you to set the message, which is shown briefly when the phone is switched on.

1. Select **Settings – Phone settings – Display – Welcome note**.
2. Your own text can be displayed. If you select this item, your phone asks you to edit the message.

• Backlight [Menu 4-3-1-3]

You can set the light-up duration you want whenever you press a key.

• LCD contrast [Menu 4-3-1-4]

You can set the brightness of LCD you want by pressing  , .

Serial port [Menu 4-3-2]

• FAX

You can set the rate of serial port to 19200bps for using the application between PC and fax.

• GPRS & Data

You can set the rate of serial port to 115200bps for using PC application for GPRS call and Data call.

Language [Menu 4-3-3]

You can select the language that will be displayed on the phone.

Call settings [Menu 4-4]



You can set the menu relevant to a call by pressing  [Select] in Setting menu.

Minute minder [Menu 4-4-1]



If you select Yes, you can check the call duration by beep sound every minute during a call.

Any key answer [Menu 4-4-2]

• Yes [Menu 4-4-2-1]

If you select this menu, you can receive an incoming call by pressing any key except  key and  key

• No [Menu 4-4-2-2]

If you select this menu, you can receive an incoming call by  [Answer] or .

Note

- **How to use Handsfree portable:**

If you want to use the handsfree portable (earphone), Please press the button for a long time after inserting it to the connector when incoming a call.

Send number [Menu 4-4-3]

(network and subscription dependent)

- **Yes [Menu 4-4-3-1]**

If you select this, you can send your phone number to the other party. That is, your phone number will be displayed on receiver's phone.

- **No [Menu 4-4-3-2]**

If you select this, you can't send your phone number.

- **Default [Menu 4-4-3-3]**

If you select this menu, this phone will be set to the default value.

Call waiting [Menu 4-4-4]

(network dependent)

If this service is available, you can accept a waiting (incoming) call.

- **Enable [Menu 4-4-4-1]**
Activating the corresponding service.
- **Disable [Menu 4-4-4-2]**
Deactivating the corresponding service.
- **Check status [Menu 4-4-4-3]**
Checking the Status of the service.

Auto redial [Menu 4-4-5]

- **Yes [Menu 4-4-5-1]**
When this function is set on, your phone will make up to 10 attempts for a call after not connecting.
- **No [Menu 4-4-5-2]**
Your phone will not make any attempts to connect the call after not connecting.

Next incoming [Menu 4-4-6]

(network dependent)

In case of Single Numbering Service, you can use the phone and a connected PC to send and receive fax, data, and voice. If you select the mode, you can receive data, fax, or voice each mode. Once you enter this menu, you following options are displayed.

- **Voice**

You can receive the voice call.

- **Data**

You can receive the data call.

- **Fax**

You can receive the fax call.

Note

- Single numbering service means that the number of fax or data service is identical with the number of voice service. And, these modes depend on network feature.

Select line [Menu 4-4-7]

(network dependent)





This function is only used if **Alternate line service** supported by the Service Provider. Two independent phone numbers are registered for the phone. This function provides you with the selection the currently used phone number. If this function is supported by your service provider, the following menu will be displayed.

1. **Line 1** : Select Line 1 as the current phone number.
2. **Line 2** : Select Line 2 as the current phone number.

Security settings [Menu 4-5]

PIN code [Menu 4-5-1]

In this menu, you can set the phone to ask for the PIN code of your SIM card when the phone is switched on. If this function is activated, you'll be requested to enter the PIN code.

1. Press  [Menu] in standby mode.
2. Press  key for direct access or use  and  to enter **Settings**.
3. Scroll to highlight **Security settings** menu.
4. Select PIN code by pressing  [Select].
5. You can view the following submenus.
 - **Enable** : Enable PIN code request.
 - **Disable** : Disable PIN code request.

Phone lock [Menu 4-5-2]

You can use security code to avoid unauthorized use of your phone. When you switch on your phone, Your phone will request security code always if you set phone lock to “Enable”. if you set phone lock to “Automatic”. Your phone will request security code only when you change your SIM card.



- **Enable**
- **Disable**
- **Automatic**

Automatic key lock [Menu 4-5-3]

When you enable Automatic key lock, keypad will be lock automatically on a idle screen after 25 seconds without any key requesting.

- **Enable**
- **Disable**

Note

- If you want to lock your phone keypad manually, enter Top menu and press  key.
- If you want to unlock your phone keypad, press [unlock] key and then press  key. But if you enabled Automatic key lock before, your phone keypad will be unlock and then after 25 seconds the keypad will be lock up again automatically.

Call barring [Menu 4-5-4]

The Call barring service prevents your phone from making or receiving certain category of calls. This function requires the call barring password. You can view the following submenus.

- **All outgoing:**

The barring service of all outgoing calls.

- **Outgoing Intl:**

The barring service of all outgoing international calls.

- **Outg. intl roam:**

The barring service of all international outgoing calls except home network.

- **All incoming:**

The barring service of all incoming calls

- **Inc when roam:**

The barring service of all incoming calls when roaming

- **Cancel all:**





You can cancel all barring service.

- **Change passwd:**

You can change the password for Call Barring Service.







Fixed dial num. [Menu 4-5-5] (SIM dependent)

You can restrict your outgoing calls to selected phone number. The numbers are protected by your PIN2 code.

1. Press  [Menu] in standby mode.
2. Press  key for direct access or use  and  to enter **Settings**.
3. Scroll to highlight **Security settings** menu.
4. Select PIN code by pressing  [Select].
5. If the PIN 2 code is correct, you can view the following submenus.
 - **On** : You can restrict your outgoing calls to selected phone number.
 - **Off** : you can call without restricting phone number.
 - **Number list** : You can view the number list saved as Fixed dial number.

Change code [Menu 4-5-6]

You can change the access codes: **PIN**, **PIN2**, and **Security code**.

1. Press  [Menu] in standby mode.
2. Press  key for direct access or use  and  to enter **Settings**.
3. Scroll to highlight **Security settings** menu.
4. Select **Change code** by pressing  [Select].
5. If you want to change the PIN/PIN2/Security code, input your original code, and then press  [OK].
6. Input new PIN/PIN2/Security code, and verify the them.

Network settings [Menu 4-6]

You can select the network which you will be registered either automatically or manually. Usually, the selection of the network used by the handset is automatic.

Automatic [Menu 4-6-1]

The phone automatically selects network which is available in the your area.

Manual [Menu 4-6-2]

The phone will find the list of available networks and show you them. Then you can select the network which you want to use if this network has a roaming agreement with your home network operator.

Preferred [Menu 4-6-3]

You can set a list of preferred networks the handset should attempt to register with first, before attempting to register to any other networks. This list is created from the handset's predefined list of known networks.

User define [Menu 4-6-4]

You can add entries or delete new ones from the network list. This can even include new networks whose network codes are not known to the handset. To do this, select and then enter the network code, country code and network name.

Restore factory settings [Menu 4-7]





You can set the handset to the default configuration by selecting the Settings/Restore factory settings option, and then confirming this selection.

Call Divert [Menu 5]

Accessing the Menu

(network and subscription dependent)

The Call divert service allows to divert incoming voice calls, fax calls, and data calls to another number. For details, contact your service provider.

1. Press  [Menu] in standby mode.
2. Press  for direct access or use  and  to enter **Call Divert**.

All voice calls [Menu 5-1]

Diverts voice calls unconditionally.

If busy [Menu 5-2]

Diverts voice calls when the phone is in progress.

If no reply [Menu 5-3]

Diverts voice calls which you do not answer.

If unreachable [Menu 5-4]

Diverts voice calls when the phone is switched off or out of range.

All data calls [Menu 5-5]

Diverts to a number with a PC connection unconditionally.

All fax calls [Menu 5-6]

Diverts to a number with a fax connection unconditionally.

The submenus [Menu 5-x-x]

Call Divert menus have the submenus as shown below.

Enable [Menu 5-x-1]

Activating the corresponding service.

- **Voicemail box [Menu 5-x-x-1]**

Forwards to message center. This function is not included in **All data calls** and **All fax calls** menus.

- **Other number [Menu 5-x-x-2]**

Inputs the number for diverting.

- **Favorite [Menu 5-x-x-3]**

Shows the list of 5 diverting numbers.

Note

- You can select the number you want in **Favorite** menu.

Disable [Menu 5-x-2]

Deactivating the corresponding service.

Check status [Menu 5-x-3]

Checking the Status of the corresponding service.

Cancel all [Menu 5-7]



Cancels all call divert service.

Scheduler [Menu 6]

Accessing the Menu

When you enter this menu a Calendar will show up. On top of the screen there are sections for date and icons. Whenever you change the date, the calendar will be updated according to the date. And square cursor will be used to locate the certain day. If you see under bar on the calendar, it means that there is a schedule that day. This function helps to remind you of your schedule and memo. The phone will sound an alarm tone if you set alarm for the note.

For changing the day, month, and year.

Key	Description
	Yearly
	Monthly
	If you press these keys shortly, you can set the alarm daily. In case of pressing for a long time, you can set it weekly.

Add new [Menu 6-1]

You can edit maximum 30 characters. You can take a note. You can choose the following types of note. You can make up to maximum 20 notes.

Schedule [Menu 6-1-1]

Input the subject, the schedule time, the repeat time, alarm time by pressing  [Select].



• Repeat [Menu 6-1-1-1]

- **Once** : no repeat.
- **Daily** : repeat schedule daily for 5 days.
- **Weekly** : repeat schedule weekly for 5 weeks.
- **Monthly** : repeat schedule monthly for 5 months.
- **Yearly** : repeat schedule yearly for 5 years.



• Alarm time [Menu 6-1-1-1-1]

- **On time** : alarm on time you set already.
- **10 min before** : alarm before 10 minutes from the schedule you set already.
- **30 min before** : alarm before 30 minutes from the schedule you set already.
- **1 hour before** : alarm before 1 hour from the schedule you set already.
- **1 day before** : alarm before 1 day from the schedule you set already.



Memo [Menu 6-1-2]

1. Select **Add new** by pressing  [Select].
2. Scroll to highlight **Memo**.
3. Press  [Select].
4. Input the memo and then press  [Select].

View day [Menu 6-2]

Shows the note for the chosen day. Use  ,  to browse through the note lists. If you set alarm for the note, Alarm watch is displayed. Press  [Options] to delete, edit the note you selected.

View all [Menu 6-3]

Shows the notes that are set for all days. Use  ,  to browse through the note lists. Pressing  [Options] allows access to the same menu as in 'View day'.

Delete passed [Menu 6-4]

You can delete for the last schedule already is notified you.

Delete all [Menu 6-5]

You can delete for the all note(s).

Game [Menu 7-1]

Your phone offers you enjoyable games to play with.

Note

The Control keys are different for each game. But each game has screens to explain the main control key. Other common control keys are below.







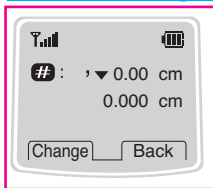

[Common Key Function]

-  [Soft 1 Key] : Start Game
-  [CLR] : Pause
-  [Soft 2 Key] : Back
-  [END] : Exit
-  [Star Key] : Backlight
-  [Soft 1 Key] : Save score
-  ,  ,  ~  : Level control
[Up/Down, numeric key]

Unit convert [Menu 7-2]







This converts any measurement into a unit you want. There are 4 types that can be converted into units: **Length, Area, Weight, and Volume.**

1. You can select one of four unit types by pressing  [Select] key.
2. Select the unit you want to convert by pressing  and .
3. You can change unit by pressing  [Change] key.
4. You can input the prime number after the decimal place by pressing  key.
5. You can delete the number you want by pressing .
6. Press  key or  [Back] key if you want to end the process for converting the value.





Calculator [Menu 7-3]

This contains the standard functions such as +, -, *, ÷ : **Add, Subtract, Multiply, Divide**

1. Input the numbers by pressing numeric keys.
2. Press  [Options] to select menu you want such as Add, Subtract, Multiply, Divide, Negative, Decimal point, Equals.
3. You can view the result by pressing  [Options] key and select **equals**.
4. If you want to continue the calculation, repeat the process.
5. You can delete the number or sign you want by pressing .
6. Press  key if you want to end the calculation process.

World time [Menu 7-4]

You can view the time for each city around the world.

when you press  ,  shortly, you can view the city belonged to the different time zone and when you press  ,  long, you can view the all of city on the same time zone.



If you want to select the country you want, press  [set] key.

Your phone supports services based on Wireless Application Protocol(WAP). You can access services supported by your network. The services menu allows you to get the information such as news, weather reports, and flight times.

Home [Menu 8-1]

You can connect to the configured homepage of the activated profile.

Bookmarks [Menu 8-2]

When you enter this menu, you can see the bookmarks. Then press  button to access available option, or press  to exit it.

- **Connect** : Connect to selected bookmark.
- **Add new** : Add a new bookmark manually.
- **Edit** : Edit the title and the address of the selected bookmark.
- **Delete** : Delete the selected bookmark from the bookmark list.

Profiles [Menu 8-3]

You can make up to 5 profiles and activate only one of them. Scroll to the desired profile and press  to access available options.

- **Activate [Menu 8-3-1-1]**

You can activate the selected profile.

- **Settings [Menu 8-3-1-2]**

You can edit and change WAP settings of the selected profile.

- **Homepage**

This setting allows you to enter the address (URL) of the site you want to use as homepage. You do not need to type “http://” in front of each URL as the WAP Browser will automatically add it.

- **Display image**

You can select whether images on WAP cards are displayed or not.

- **Conn. type**

The options for connection type are Continuous or Temporary and depend on the gateway.

Continuous

A confirmed delivery mechanism but generates more network traffic.

Temporary

A non-confirmed (connectionless) service.

- **Secure setting**

The options are **On** and **Off** depend on the gateway you are using.

- **Gateway info.**

Most of WAP gateways do not require a User ID and Password. If your gateway need them to connect to it, then your network should provide them, and you must set them up correctly before trying to browse a WAP site.

- Bearer

Data

GPRS

- Data setting

These values of setting are provided by your network.

IP address : Enter the IP address of the WAP gateway you are using to access.

Dial number : Enter the telephone number to dial to access your WAP gateway.

Call type : Select the type of data call.: Analogue or ISDN (Digital).

Call speed : The speed of your data connection.

User ID : The user identity for your dial-up server (and NOT the WAP gateway).

Password : The password required by your dial-up server (and NOT the WAP gateway) to identify you.

- GPRS settings

The service settings are only available when GPRS is chosen as a bearer service.

- Linger time

You need to select one of 5 timeout periods. After selecting one of them, the service will be unavailable if any data wasn't input or transferred.

- **Rename [Menu 8-3-1-3]**

Edit the Profile Name.

- **E-mail server [Menu 8-3-1-4]**

Save the URL of the E-mail server that you frequently use.

- **Connect**

- Connect to the E-mail server that you configured.

- **Edit address**

- Edit the URL of the E-mail server.

Go to URL [Menu 8-4]

You can directly connect to the site that you want. You need to enter the specific URL that you want to directly connect.

Cache settings [Menu 8-5]

You can remove the contents of Cache memory and change the Cache check mode.

Clear cache [Menu 8-5-1]

The contents of Cache memory will be removed.

Cache check [Menu 8-5-2]

You can change the time for checking the Cache memory.

- **Always [Menu 8-5-2-1]**

The cache is always checked whenever URL is loaded or navigated.

- **Start only [Menu 8-5-2-2]**

The cache is only checked when the WAP is started.

- **Off [Menu 8-5-2-3]**

The cache is never checked.

Security certifications [Menu 8-6]

A list of the available certificates is shown.

Reset profiles [Menu 8-7]

You can reset all the current settings of profiles to the factory default.

If you are on line, you can see the following menus.

Home

This is the same as [Menu 8-1].

Reload

This reloads the current page.

Bookmarks

This is the same as [Menu 8-2].

Save as bookmarks

Save the current URL as a bookmark. You can also edit the bookmark title.

Go to URL

Same as [Menu 8-4]

Go to e-mail server

Connect to the E-mail server that you configured.

Set as e-mail server

Save the current URL as an E-mail server.

How to Use Data and Fax call

Additional Functions

To be able to data or fax service, you need the communicate software such as a data or a fax program. Before using these functions, you need to connect your phone to a computer or make sure that your phone is in connection with a compatible device.

Sending Data or Fax Calls

1. Connect your computer to the phone.
2. After starting the communicate software, make a call and transmit a data or fax.
3. After the data or fax transmission, you can end the call by just ending of the communicate software, pressing  [End] or by closing the folder.

Receiving Data or Fax Calls

If you have separate numbers for voice, data and fax calls, your phone recognizes the type of call.

Receiving Data or Fax Calls—Separate numbers (Multi-numbers)

To use a data or a fax service, the display shows which type of call you are receiving.

To receive a data or fax call



1. Connect your computer to the phone.
2. After starting the communicate software, accept a call and receive a data or fax (if it is not answered automatically).
3. After the data or fax reception, you can end the call by just ending of the communicate software, pressing  [End] or by closing the folder.

Receiving Data or Fax Calls—Single number

If you have a SIM card that does not support separate voice, data and fax numbers, the phone does not recognize the type of incoming call.

To use a data or a fax service, make sure that you want to receive a data or fax call mode. You first have to set the phone to one of these options in the call mode (Settings → Call Setting → Next Incoming) sub menu.

To receive a data or fax call

1. Press  [Menu] in standby mode.
2. Select the Settings → Call setting → Next Incoming.
3. Select the call type you want (Voice, Data or Fax) and press  [Select].
4. Connect your computer to the phone.
5. After starting the communicate software, accept a call and receive a data or fax (if it is not answered automatically).
6. After the data or fax reception, you can end the call by just ending of the communicate software, pressing  [End] or by closing the folder.

Once you have set your phone for a specific incoming call, it remains set until you change it.



PC Sync

PC Sync is a program for data exchange PC & Phone by data cable. Therefore, if you want to use this function, you have to buy accessory kit. About more detail for using guide refers to PC Sync Help file on the PC Sync CD.



During a call, the following menus will be displayed, not in a standby mode.

1 During a call



1-1 Putting a Call on Hold

You can place a call on hold or retrieve by just pressing the  [Send] key. When a call is made or answered, press the  [Send] key to place it on hold. When a call is held, press the  [Send] key to make it active.

1-2 Making a Second Call

You can get a dial number from phonebook to make a second call. Press  [Names] key then select **Search**. To save the dial number into phonebook during call, press  [Names] key then select **Add Entry**.

1-3 Swapping Between Two Calls



To switch between two calls, select the  [Menu] key, then select Swap or just press  [Send] key.

You can make one of two calls focused by pressing up/down arrow key. If you want to end one of two calls, make the call you want to end focused, then press  [End] key when the call you want to end is focused.

1-4 Answering an Incoming Call

To answer an incoming call, simply press the  [Send] key.



The handset is also able to warn you of an incoming call while you are already in a call. A tone sounds in the earpiece, and the display will show that a second call is waiting.

If Call Waiting is on, you can put the first call on hold and answer the second, by pressing  [Send] or by selecting the  [Menu] key, then **Hold & Answer**.

You can end the current call and answer the waiting call by selecting the  [Menu] key, then **End & Answer**.

1-5 Rejecting an Incoming Call



You can reject an incoming call without answering by simply pressing the  [End] key.

When in a call you can reject an incoming call by pressing the  [Menu] key and selecting **Multiparty/Reject** or by pressing  [End] key.

1-6 Controlling the volume during a call

You can control the volume during a call by pressing  [Menu] key and selecting **Volume**.

1-7 Muting the Microphone

You can mute the microphone during a call by pressing the  [Menu] key then selecting **Mute**. The handset can be unmuted by pressing the  [Unmute] .

When the handset is muted, the caller cannot hear you, but you can still hear them.

1-8 Switching DTMF Tones on During a Call

To turn DTMF tones on during a call, for example, to allow your handset to make use of an automated switchboard, select the  [Menu] key, then **DTMF On**. DTMF tones can be turned off the same way.

1-9 Calling up the Main Menu

The Messages and SIM Tool kit main menu options can be reached from the in-call menu by selecting the  [Menu] key, then **Main Menu**. SIM Tool kit menu is shown only when SIM in the handset supports SIM Tool kit service.



2 Multiparty or Conference Calls

The multiparty or conference service provides you with the ability to have a simultaneous conversation with more than one caller, if your network service provider supports this feature.

A multiparty call can only be set up when you have one active call and one call on hold, both calls having been answered. Once a multiparty call is set up, calls may be added, disconnected or separated (that is, removed from the multiparty call but still connected to you) by the person who set up the multiparty call. These options are all available from the in-call menu and are listed in Section.

The maximum callers in a multiparty call is five. Once started, you are in control of the multiparty call, and only you can add calls to the multiparty call.

2-1 Making a Second Call

You can make a second call while you are already in a call. To do this, enter the second number and press  [Send]. When you get second call the first call is automatically put on hold. You can swap between calls by selecting the  [Menu] key then **Swap**.

2-2 Setting up a Multiparty Call

You can connect a call on hold to the currently active call to form a multiparty call by selecting the  [Menu] key then **Multiparty/Join all**.

2-3 Putting the Multiparty Call on Hold

To put a multiparty call on hold, select the  [Menu] key then **Multiparty/Hold all**.



2-4 Activate the Multiparty Call on Hold

To make a multiparty call on hold active, select the  [Menu] key then **Multiparty/Join all**.

2-5 Adding Calls to the Multiparty Call

To join an active call to the held multiparty call, select the  [Menu] key then **Multiparty/Join all**.

2-6 Displaying Callers in a Multiparty Call

To scroll through the numbers of the callers who make up a multiparty call on the handset screen, press  and  keys.



2-7 Putting a Member of a Multiparty Call on Hold

To place one selected caller (whose number is currently displayed on-screen) of a multiparty call on hold, select the  [Menu] key then **Multiparty/Exclude**.

2-8 A Private Call in a Multiparty Call

To have a private call with one caller of a multiparty call, display the number of the caller you wish to talk to on the screen, then select the  [Menu] key and **Multiparty/Private** to put all the other callers on hold.

2-9 Ending a Multiparty Call

The currently displayed caller of a multiparty call can be disconnected by pressing the  [End] key. To end a multiparty call, press the  [Menu] key then select **Multiparty/End** multiparty.

Selecting the  [Menu] key then **Multiparty/End all**, will end all the active and held calls.

2-10 Explicit Call Transfer (ECT)

If you have one caller on hold and another active call, you may connect one call party to another call party and then leave the call. This is done by selecting the **Multiparty/Transfer** option from the in-call menu.

Accessories

There are various accessories for your mobile phone. You can select these options according to your personal communication requirements.



Standard Battery



Portable Handsfree

This connects to your phone, allowing handsfree operation.



Travel Adapter

This charger allows you to charge the battery while away from home or your office.

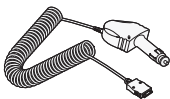

Cigar Lighter Adapter

You can operate the phone and trickle charge the phone's battery from your vehicle by using the cigarette lighter charger.

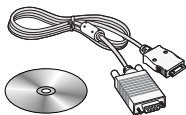

Data Kit/CD

You can connect your phone to PC to exchange the data between them.

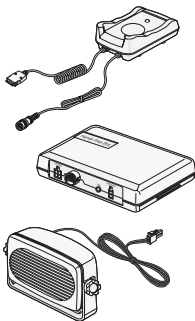

Handsfree Kit

The handsfree car kit enables you to attach the phone to the power jack in your car, providing you with handsfree operation.

Note

- Information and specification in this menu is subject to change without prior notice.
- Accessories may be different in different regions; please check with our regional service company or agent for further enquiries.

TIA Safety Information

Provided herein is the complete TIA Safety Information for Wireless Handheld phones. Inclusion of the text covering Pacemakers, Hearing Aids, and Other Medical Devices is required in the owner's manual for CTIA Certification. Use of the remaining TIA language is encouraged when appropriate.

Exposure to Radio Frequency Signal

Your wireless handheld portable telephone is a low-power radio transmitter and receiver. When it is ON, it receives and also sends out radio frequency (RF) signals. In August, 1996, the Federal Communications Commission (FCC) adopted RF exposure guidelines with safety levels for handheld wireless phones. Those guidelines are consistent with the safety standards previously set by both U.S. and international standards bodies:

ANSI C95.1 (1992) *

NCRP Report 86 (1986)

ICNIRP (1996)

Those standards were based on comprehensive and periodic evaluations of the relevant scientific literature. For example, over 120 scientists, engineers, and physicians from universities, government health agencies, and industry reviewed the available body of research to develop the ANSI Standard (C95.1).

*American National Standards Institute; National Council on Radiation Protection and Measurements; International Commission on Non-Ionizing Radiation Protection

The design of your phone complies with the FCC guidelines (and those standards).

Antenna Care

Use only the supplied or an approved replacement antenna. Unauthorized antennas, modifications, or attachments could damage the phone and may violate FCC regulations.

Phone Operation

NORMAL POSITION: Hold the phone as you would any other telephone with the antenna pointed up and over your shoulder.

Tips on Efficient Operation

For your phone to operate most efficiently:

- Antenna is fixed and does not extend. This line is not necessary.
- Do not touch the antenna unnecessarily when the phone is in use. Contact with the antenna affects call quality and may cause the phone to operate at a higher power level than otherwise needed.

Driving

Check the laws and regulations on the use of wireless phones in the areas where you drive. Always obey them. Also, if using your phone while driving, please:

- Give full attention to driving — driving safely is your first responsibility;
- Use hands-free operation, if available;
- Pull off the road and park before making or answering a call if driving conditions so require.

Electronic Devices

Most modern electronic equipment is shielded from RF signals. However, certain electronic equipment may not be shielded against the RF signals from your wireless phone.

Safety Guidelines

Pacemakers

The Health Industry Manufacturers Association recommends that a minimum separation of six (6") inches be maintained between a handheld wireless phone and a pacemaker to avoid potential interference with the pacemaker. These recommendations are consistent with the independent research by and recommendations of Wireless Technology Research.

Persons with pacemakers:

- Should ALWAYS keep the phone more than six inches from their pacemaker when the phone is turned ON;
- Should not carry the phone in a breast pocket.
- Should use the ear opposite the pacemaker to minimize the potential for interference.
- If you have any reason to suspect that interference is taking place, turn your phone OFF immediately.

Hearing Aids

Some digital wireless phones may interfere with some hearing aids. In the event of such interference, you may want to consult your service provider.

Other Medical Devices

If you use any other personal medical device, consult the manufacturer of your device to determine if they are adequately shielded from external RF energy. Your physician may be able to assist you in obtaining this information.

Turn your phone OFF in health care facilities when any regulations posted in these areas instruct you to do so. Hospitals or health care facilities may be using equipment that could be sensitive to external RF energy.

Vehicles

RF signals may affect improperly installed or inadequately shielded electronic systems in motor vehicles. Check with the manufacturer or its representative regarding your vehicle.

You should also consult the manufacturer of any equipment that has been added to your vehicle.

Posted Facilities

Turn your phone OFF in any facility where posted notices so require.

Aircraft

FCC regulations prohibit using your phone while in the air. Turn your phone OFF before boarding an aircraft.

Blasting Areas

To avoid interfering with blasting operations, turn your phone OFF when in a “blasting area” or in areas posted: “Turn off two-way radio”. Obey all signs and instructions.

Potentially Explosive Atmosphere

Turn your phone OFF when in any area with a potentially explosive atmosphere and obey all signs and instructions. Sparks in such areas could cause an explosion or fire resulting in bodily injury or even death.

Areas with a potentially explosive atmosphere are often, but not always, marked clearly. Potential areas may include: fueling areas (such as gasoline stations); below deck on boats; fuel or chemical transfer or storage facilities; vehicles using liquefied petroleum gas (such as propane or butane); areas where the air contains chemicals or particles (such as grain, dust, or metal powders); and any other area where you would normally be advised to turn off your vehicle engine.

Safety Guidelines

For Vehicles Equipped with an Air Bag

An air bag inflates with great force. DO NOT place objects, including either installed or portable wireless equipment, in the area over the air bag or in the air bag deployment area. If in-vehicle wireless equipment is improperly installed and the air bag inflates, serious injury could result.

TIA Safety Information

The U.S. Food and Drug Administration's Center for Devices and Radiological Health Consumer Update on Mobile Phones.

1. Do wireless phones pose a health hazard?

The available scientific evidence does not show that any health problems are associated with using wireless phones. There is no proof, however, that wireless phones are absolutely safe. Wireless phones emit low levels of radiofrequency energy (RF) in the microwave range while being used. They also emit very low levels of RF when in the standby mode. Whereas high levels of RF can produce health effects (by heating tissue), exposure to low level RF that does not produce heating effects causes no known adverse health effects. Many studies of low level RF exposures have not found any biological effects. Some studies have suggested that some biological effects may occur, but such findings have not been confirmed by additional research. In some cases, other researchers have had difficulty in reproducing those studies, or in determining the reasons for inconsistent results.

2. What is the FDA's role concerning the safety of wireless phones?

Under the law, the FDA does not review the safety of radiation-emitting consumer products such as wireless phones before they can be sold, as it does with new drugs or medical devices. However, the agency has authority to take action if wireless phones are shown to emit radiofrequency energy (RF) at a level that is hazardous to the user. In such a case, the FDA could require the manufacturers of wireless phones to notify users of the health hazard and to repair, replace, or recall the phones so that the hazard no longer exists. Although the existing scientific data do not justify FDA regulatory actions, the FDA has urged the wireless phone industry to take a number of steps, including the following:

- Support needed research into possible biological effects of RF of the type emitted by wireless phones;
- Design wireless phones in a way that minimizes any RF exposure to the user that is not necessary for device function; and
- Cooperate in providing users of wireless phones with the best possible information on possible effects of wireless phone use on human health.

The FDA belongs to an interagency working group of the federal agencies that have responsibility for different aspects of RF safety to ensure coordinated efforts at the federal level. The following agencies belong to this working group:

- National Institute for Occupational Safety and Health
- Environmental Protection Agency
- Occupational Safety and Health Administration
- National Telecommunications and Information Administration

Safety Guidelines

The National Institutes of Health participates in some interagency working group activities, as well.

The FDA shares regulatory responsibilities for wireless phones with the Federal Communications Commission (FCC). All phones that are sold in the United States must comply with FCC safety guidelines that limit RF exposure. The FCC relies on the FDA and other health agencies for safety questions about wireless phones.

The FCC also regulates the base stations that the wireless phone networks rely upon. While these base stations operate at higher power than do the wireless phones themselves, the RF exposures that people get from these base stations are typically thousands of times lower than those they can get from wireless phones. Base stations are thus not the subject of the safety questions discussed in this document.

3. What kinds of phones are the subject of this update?

The term “wireless phone” refers here to handheld wireless phones with built-in antennas, often called “cell”, “mobile”, or “PCS” phones. These types of wireless phones can expose the user to measurable radiofrequency energy (RF) because of the short distance between the phone and the user’s head. These RF exposures are limited by FCC safety guidelines that were developed with the advice of the FDA and other federal health and safety agencies. When the phone is located at greater distances from the user, the exposure to RF is drastically lower because a person’s RF exposure decreases rapidly with increasing distance from the source. The so-called “cordless phones,” which have a base unit connected to the telephone wiring in a house, typically operate at far lower power levels, and thus produce RF exposures far below the FCC safety limits.

4. What are the results of the research done already?

The research done thus far has produced conflicting results, and many studies have suffered from flaws in their research methods. Animal experiments investigating the effects of radiofrequency energy (RF) exposures characteristic of wireless phones have yielded conflicting results that often cannot be repeated in other laboratories. A few animal studies, however, have suggested that low levels of RF could accelerate the development of cancer in laboratory animals. However, many of the studies that showed increased tumor development used animals that had been genetically engineered or treated with cancer-causing chemicals so as to be pre-disposed to develop cancer in the absence of RF exposure. Other studies exposed the animals to RF for up to 22 hours per day. These conditions are not similar to the conditions under which people use wireless phones, so we don't know with certainty what the results of such studies mean for human health. Three large epidemiology studies have been published since December 2000. Between them, the studies investigated any possible association between the use of wireless phones and primary brain cancer, glioma, meningioma, or acoustic neuroma, tumors of the brain or salivary gland, leukemia, or other cancers. None of the studies demonstrated the existence of any harmful health effects from wireless phone RF exposures. However, none of the studies can answer questions about long-term exposures, since the average period of phone use in these studies was around three years.

5. What research is needed to decide whether RF exposure from wireless phones poses a health risk?

A combination of laboratory studies and epidemiological studies of people actually using wireless phones would provide some of the data that are needed. Lifetime animal exposure studies could be completed in a few years. However, very large numbers of animals would be needed to provide reliable proof of a cancer promoting effect if one exists. Epidemiological studies can provide data that is directly applicable to human populations, but 10 or more years follow-up may be needed to provide answers about some health effects, such as cancer. This is because the interval between the time of exposure to a cancer-causing agent and the time tumors develop – if they do – may be many, many years. The interpretation of epidemiological studies is hampered by difficulties in measuring actual RF exposure during day-to-day use of wireless phones. Many factors affect this measurement, such as the angle at which the phone is held, or which model of phone is used.

6. What is the FDA doing to find out more about the possible health effects of wireless phone RF?

The FDA is working with the U.S. National Toxicology Program and with groups of investigators around the world to ensure that high priority animal studies are conducted to address important questions about the effects of exposure to radiofrequency energy (RF). The FDA has been a leading participant in the World Health Organization International Electromagnetic Fields (EMF) Project since its inception in 1996. An influential result of this work has been the development of a detailed agenda of research needs that has driven the establishment of new research programs around the world. The project has also helped develop a series of public information documents on EMF issues.

The FDA and the Cellular Telecommunications & Internet Association (CTIA) have a formal Cooperative Research and Development Agreement (CRADA) to do research on wireless phone safety. The FDA provides the scientific oversight, obtaining input from experts in government, industry, and academic organizations. CTIA-funded research is conducted through contracts with independent investigators. The initial research will include both laboratory studies and studies of wireless phone users. The CRADA will also include a broad assessment of additional research needs in the context of the latest research developments around the world.

7. How can I find out how much radio frequency energy exposure I can get by using my wireless phone?

All phones sold in the United States must comply with Federal Communications Commission (FCC) guidelines that limit radio frequency energy (RF) exposures. The FCC established these guidelines in consultation with the FDA and the other federal health and safety agencies. The FCC limit for RF exposure from wireless telephones is set at a Specific Absorption Rate (SAR) of 1.6 watts per kilogram (1.6 W/kg). The FCC limit is consistent with the safety standards developed by the Institute of Electrical and Electronic Engineering (IEEE) and the National Council on Radiation Protection and Measurement. The exposure limit takes into consideration the body's ability to remove heat from the tissues that absorb energy from the wireless phone and is set well below levels known to have effects. Manufacturers of wireless phones must report the RF exposure level for each model of phone to the FCC. The FCC website (<http://www.fcc.gov/oet/rfsafety>) gives directions for locating the FCC identification number on your phone so you can find your phone's RF exposure level in the online listing.

8. What has the FDA done to measure the radio frequency energy coming from wireless phones?

The Institute of Electrical and Electronic Engineers (IEEE) is developing a technical standard for measuring the radio frequency energy (RF) exposure from wireless phones and other wireless handsets with the participation and leadership of FDA scientists and engineers. The standard, “Recommended Practice for Determining the Spatial-Peak Specific Absorption Rate (SAR) in the Human Body Due to Wireless Communications Devices: Experimental Techniques,” sets forth the first consistent test methodology for measuring the rate at which RF is deposited in the heads of wireless phone users. The test method uses a tissue-simulating model of the human head. Standardized SAR test methodology is expected to greatly improve the consistency of measurements made at different laboratories on the same phone. SAR is the measurement of the amount of energy absorbed in tissue, either by the whole body or a small part of the body. It is measured in watts/kg (or milliwatts/g) of matter. This measurement is used to determine whether a wireless phone complies with safety guidelines.

9. What steps can I take to reduce my exposure to radiofrequency energy from my wireless phone?

If there is a risk from these products – and at this point we do not know that there is – it is probably very small. But if you are concerned about avoiding even potential risks, you can take a few simple steps to minimize your exposure to radiofrequency energy (RF). Since time is a key factor in how much exposure a person receives, reducing the amount of time spent using a wireless phone will reduce RF exposure.

If you must conduct extended conversations by wireless phone every day, you could place more distance between your body and the source of the RF, since the exposure level drops off dramatically with distance. For example, you could use a headset and carry the wireless phone away from your body or use a wireless phone connected to a remote antenna. Again, the scientific data do not demonstrate that wireless phones are harmful. But if you are concerned about the RF exposure from these products, you can use measures like those described above to reduce your RF exposure from wireless phone use.

10. What about children using wireless phones?

The scientific evidence does not show a danger to users of wireless phones, including children and teenagers. If you want to take steps to lower exposure to radiofrequency energy (RF), the measures described above would apply to children and teenagers using wireless phones. Reducing the time of wireless phone use and increasing the distance between the user and the RF source will reduce RF exposure. Some groups sponsored by other national governments have advised that children be discouraged from using wireless phones at all. For example, the government in the United Kingdom distributed leaflets containing such a recommendation in December 2000. They noted that no evidence exists that using a wireless phone causes brain tumors or other ill effects. Their recommendation to limit wireless phone use by children was strictly precautionary; it was not based on scientific evidence that any health hazard exists.

11. What about wireless phone interference with medical equipment?

Radio frequency energy (RF) from wireless phones can interact with some electronic devices. For this reason, the FDA helped develop a detailed test method to measure electromagnetic interference (EMI)

Safety Guidelines

of implanted cardiac pacemakers and defibrillators from wireless telephones. This test method is now part of a standard sponsored by the Association for the Advancement of Medical Instrumentation (AAMI). The final draft, a joint effort by the FDA, medical device manufacturers, and many other groups, was completed in late 2000. This standard will allow manufacturers to ensure that cardiac pacemakers and defibrillators are safe from wireless phone EMI. The FDA has tested hearing aids for interference from handheld wireless phones and helped develop a voluntary standard sponsored by the Institute of Electrical and Electronic Engineers (IEEE). This standard specifies test methods and performance requirements for hearing aids and wireless phones so that no interference occurs when a person uses a “compatible” phone and a “compatible” hearing aid at the same time. This standard was approved by the IEEE in 2000.

The FDA continues to monitor the use of wireless phones for possible interactions with other medical devices. Should harmful interference be found to occur, the FDA will conduct testing to assess the interference and work to resolve the problem.

12. Where can I find additional information?

For additional information, please refer to the following resources:
FDA web page on wireless phones

(<http://www.fda.gov/cdrh/phones/index.html>) Federal

Communications Commission (FCC) RF Safety Program

(<http://www.fcc.gov/oet/rfsafety>) International Commission on Non-ionizing Radiation Protection (<http://www.icnirp.de>) World Health Organization (WHO) International EMF Project

(<http://www.who.int/emf>) National Radiological Protection Board (UK) (<http://www.nrpb.org.uk/>)

Consumer Information on SAR (Specific Absorption Rate)

This Model Phone Meets the Government's Requirements for Exposure to Radio Waves.

Your wireless phone is a radio transmitter and receiver. It is designed and manufactured not to exceed the emission limits for exposure to radio frequency (RF) energy set by the Federal Communications Commission (FCC) of the U.S. Government. These limits are part of comprehensive guidelines and establish permitted levels of RF energy for the general population. The guidelines are based on standards that were developed by independent scientific organizations through periodic and thorough evaluation of scientific studies. The standards include a substantial safety margin designed to assure the safety of all persons, regardless of age and health.

The exposure standard for wireless mobile phones employs a unit of measurement known as the Specific Absorption Rate, or SAR. The SAR limit set by the FCC is 1.6W/kg. * Tests for SAR are conducted using standard operating positions specified by the FCC with the phone transmitting at its highest certified power level in all tested frequency bands. Although SAR is determined at the highest certified power level, the actual SAR level of the phone while operating can be well below the maximum value. Because the phone is designed to operate at multiple power levels to use only the power required to reach the network, in general, the closer you are to a wireless base station antenna, the lower the power output.

Before a phone model is available for sale to the public, it must be tested and certified to the FCC that it does not exceed the limit established by the government-adopted requirement for safe exposure. The tests are performed in positions and locations (e.g., at the ear and worn on the body) as required by the FCC for each

Safety Guidelines

model. The highest SAR value for this model phone when tested for use at the ear is 0.27 W/kg and when worn on the body, as described in this user's manual, is 0.25 W/kg. (Body-worn measurements differ among phone models, depending upon available accessories and FCC requirements.) While there may be differences between SAR levels of various phones and at various positions, they all meet the government requirement for safe exposure.

The FCC has granted an Equipment Authorization for this model phone with all reported SAR levels evaluated as in compliance with the FCC RF emission guidelines. SAR information on this model phone is on file with the FCC and can be found under the Display Grant section of <http://www.fcc.gov/oet/fccid> after searching on FCC ID BEJG1500.

Additional information on Specific Absorption Rates (SAR) can be found on the Cellular Telecommunications Industry Association (CTIA) website at <http://www.wow-com.com>

*In the United States and Canada, the SAR limit for mobile phones used by the public is 1.6 watts/kg (W/kg) averaged over one gram of tissue. The standard incorporates a substantial margin of safety to give additional protection for the public and to account for any variations in measurements.

General

Product Name : G1500

System : GSM 900/DCS 1800 – GPRS class 8 (4+1)

Ambient Temperatures

Max : +55°C

Min : -10°C

Memo
