

Dell™ 1800FP Color Monitor User's Guide

English

français

Deutsch

Italiano

Español

Polski

Português do Brasil

日本語

한국어

简体中文

繁體中文

ไทย

<http://www.dell.com>

Dell and the *DELL* logo are trademarks of Dell Computer Corporation

Dell™ 1800FP Color Display User's Guide

Preface

Safety Instructions

Introduction

Setup

Using the Display

Troubleshooting

Specifications

Regulatory Notices

Limited Warranties

Documentation

**Information in this document is subject to change without notice.
© 2002 Dell Computer Corporation. All rights reserved.**

Reproduction in any manner whatsoever without the written permission of Dell Computer Corporation is strictly forbidden.

Trademarks used in this text: *Dell* and the *DELL* logo are trademarks of Dell Computer Corporation; *Microsoft*, *Windows*, and *Windows NT* are registered trademarks of Microsoft Corporation; *VESA* is a registered trademark of Video Electronics Standards Association; *IBM* is a registered trademark of International Business Machines Corporation; *Adobe* is a trademark of Adobe Systems Incorporated, which may be registered in certain jurisdictions. As an ENERGY STAR Partner, Dell Computer Corporation has determined that this product meets the ENERGY STAR guidelines for energy efficiency.

Other trademarks and trade names may be used in this document to refer to either the entities claiming the marks and names or their products. Dell Computer Corporation disclaims any proprietary interest in trademarks and trade names other than its own.

Initial release:05/13/2002

Preface: Dell™ 1800FP Color Display User's Guide

[About This Guide](#) • [Notational Conventions](#)

About This Guide

This guide is intended for anyone who uses the Dell 1800FP Color Display. It describes the display's features, setup, and operation.

The sections are as follows:

- [Safety Instructions](#) lists safety information.
 - Introduction gives an overview of the display's features and provides an orientation to the display.
 - [Setup](#) describes the initial setup process.
 - [Using the Display](#) gives an overview of how to use the display.
 - [Troubleshooting](#) provides tips and solutions for common problems.
 - [Specifications](#) lists the technical specifications of the display.
 - [Regulatory](#) lists regulatory certifications and notices.
 - [Limited Warranty](#) describes the warranty information for this product.
 - [Documentation](#) provides additional documentation that supports this product.
-

Notational Conventions

The following subsections describe notational conventions used in this document.

Notes, Cautions, and Warnings

Throughout this guide, blocks of text may be accompanied by an icon and printed in bold type or in italic type. These blocks are notes, cautions, and warnings, and they are used as follows:



NOTE: A **NOTE** indicates important information that helps you make better use of your computer system.



CAUTION: A **CAUTION** indicates either potential damage to hardware or loss of data and tells you how to avoid the problem.



WARNING: A **WARNING** indicates the potential for bodily harm and tells you how to avoid the problem.

Some warnings may appear in alternate formats and may be unaccompanied by an icon. In such cases, the specific presentation of the warning is mandated by regulatory authority.

Safety Instructions: Dell™ 1800FP Color Display User's Guide



WARNING: Use of controls, adjustments, or procedures other than those specified in this documentation may result in exposure to shock, electrical hazards, and/or mechanical hazards.

Read and follow these instructions when connecting and using your computer display:

- To help avoid damaging your computer, be sure that the voltage selection switch on the power supply is set to match the alternating current (AC) power available at your location:
 - 115 volts (V)/60 hertz (Hz) in most of North and South America and some Far Eastern countries such as Japan, South Korea, and Taiwan.
 - 230 V/50 Hz in most of Europe, the Middle East, and the Far East

Also be sure that your display is electrically rated to operate with the AC power available in your location.

- Never insert anything metallic into the display openings. Doing so may create the danger of electric shock.
 - To avoid electric shock, never touch the inside of the display. Only a qualified technician should open the display's case.
 - Never use your display if the power cable has been damaged. Do not allow anything to rest on the power cable, and keep the cable away from where people could trip over it.
 - Be sure to hold the plug, not the cable, when disconnecting the display from an electric socket.
 - Openings in the display cabinet are provided for ventilation. To prevent overheating, these openings should not be blocked or covered. Also, avoid using the display on a bed, sofa, rug, or other soft surface. Doing so may block the ventilation openings in the bottom of the cabinet. If you put the display in a bookcase or some other enclosed space, be sure to provide adequate ventilation.
 - Put your display in a location with low humidity and a minimum of dust. Avoid places like damp basement or dusty hallways.
 - Do not expose the display to rain or use it near water (in kitchens, next to swimming pools, etc.). If the display accidentally gets wet, unplug it and contact an authorized dealer immediately. You can clean the display with a damp cloth when necessary, but be sure to unplug the display first.
 - Place the display on a solid surface and treat it carefully. The screen is made of glass and can be damaged if dropped or sharply hit.
 - Locate your display near an easily accessible electric outlet.
 - If your display does not operate normally - in particular, if there are any unusual sounds or smells coming from it - unplug it immediately and contact an authorized dealer or service center.
 - Do not attempt to remove the back cover, as you will be exposed to a shock hazard. The back cover should only be removed by qualified service personnel.
 - High temperatures can cause problems. Don't use your display in direct sunlight, and keep it away from heaters, stoves, fireplaces, and other sources of heat.
 - Unplug the display when it is going to be left unused for an extended period of time.
 - Unplug your display from the electric outlet before any service.
-

Introduction: Dell™ 1800FP Color Display User's Guide

[Overview](#) • [Graphics](#)

Overview

Thank you for purchasing the Dell 1800FP Flat Panel color display. The 1800FP utilizes an 18.1-inch (45.9 cm) Active Matrix TFT LCD that displays brilliant images of text and graphics with a maximum resolution up to 1280 x 1024 pixels. This display is optimal for desktop publishing, spreadsheets, multimedia, and other applications that demand large screen size and high resolution. The Dell 1800FP was designed for a wide variety of users ranging from the home to corporate or financial trading environments. Those who require exceptional quality and reliability at an affordable price will appreciate the value that the Dell 1800FP provides.

For more details see [Specifications](#) Section.

Graphics

The following links show various views of the display and its components.

- [Front View](#)
- [Back View](#)
- [Bottom View](#)
- [Side View](#)

Specifications: Dell™ 1800FP Color Display User's Guide

[General](#) • [Flat Panel](#) • [Resolution](#) • [Preset Display Modes](#) • [Electrical](#) • [Physical Characteristics](#) • [Environmental](#) • [Power Management](#) • [Modes](#) • [Pin Assignments](#) • [Plug and Play Capability](#)

General

Model number 1800FP

Flat Panel

Screen type Active matrix - TFT LCD

Screen dimensions
Diagonal 18.1 inches (459.7 mm)
Horizontal 14.14 inches (359.04 mm)
Vertical 11.31 inches (287.23 mm)

Pixel pitch 0.2805 mm

Viewing angle +/- 80° (vertical) typical, +/- 80° (horizontal) typical

Luminance output 250 CD/m² typical, 200 CD/m² minimum

Contrast ratio 350 to 1 typical, 200 to 1 minimum

LCD surface coating Hardness 3H, antiglare treatment

Backlight 6 CCFL type

Resolution

Horizontal scan range Analog: 31 - 80 kHz (automatic)
Digital: 31 - 70kHz (automatic)

Vertical scan range 55 Hz to 75Hz (automatic)

Optimal preset resolution 1280 x 1024 at 60 Hz

Highest preset resolution 1280 x 1024 at 75 Hz

Dell guarantees image size and centering for all preset modes listed in the following table.

Preset Display Modes

Display Mode	Horizontal Frequency (kHz)	Vertical Frequency (Hz)	Pixel Clock (MHz)	Sync Polarity (Horizontal / Vertical)
VGA, 720 x 400	31.468	70	28.321	-

VGA, 640x480	31.469	60	25.175	-
VESA, 640 x 480	37.500	75	31.5	-
VESA, 800 x 600	37.879	60	40.0	+
VESA, 800 x 600	46.875	75	49.5	+
VESA, 1024 x 768	48.363	60	65.0	-
VESA, 1024 x 768	60.123	75	78.75	-
MAC, 1152 x 864	67.5	75	108.0	+/-
VESA, 1280 x 1024	63.981	60	108.0	+
VESA, 1280 x 1024(Analog D-sub only)	79.976	75	135.0	+

Electrical

Video input signals	Analog RGB, 0.7 Volts +/-5%, 75 ohm input impedance Digital DVI-D TMDS, 600mV for each differential line, 50 ohm input impedance
Synchronization input signals	separate horizontal and vertical; 3.3V Cmos or 5V TTL level, positive or negative sync. Sync on Green Composite Sync
AC input voltage / frequency / current	AC 100-240V 50/60 Hz 1.0 (RMS) max
Inrush current at 120 V	30 A max
Inrush current at 220 V	50 A max

Physical Characteristics

Connector type	15-pin D-subminiature; DVI-D
Signal cable type	Detachable
Dimensions:(with stand)	
Height	16.97inches (431mm)
Width	15.98inches (406mm)
Depth	8.78inches (223mm)
Weight (display only)	17.19 lb (7.8 kg)
Weight (with packaging)	22.05 lb (10 kg)

Environmental

Temperature:

Operating 41° to 95°F (5° to 35 °C)

Nonoperating -4° to 140°F (-20° to 60°C)

Humidity:

Operating 10% to 80% (noncondensing)

Nonoperating 5% to 95% (noncondensing)

Altitude:

Operating 3,048 m (12,000 ft)

Nonoperating 12,192 m (40,000 ft)

Thermal dissipation 213 BTU/hour (maximum)
205 BTU/hour (typical)

Power Management Modes

If you have a VESA DPMS compliant display card or software installed in your PC, the display can automatically reduce its power consumption when not in use. If input from keyboard, mouse or other input devices is detected, the display will automatically "wake up". The following table shows the power consumption and signaling of this automatic power saving feature:

Power Management Definition						
VESA's Mode	Video	H-sync	V-sync	Power Used	Power Saving	LED color
ON	Active	Yes	Yes	maximum 55W normal 50W	--	Green
Stand-by	Blanked	No	Yes	≤ 3W	>90%	Amber
Suspend	Blanked	Yes	No	≤ 3W	>90%	Amber
Active-Off*	Blanked	No	No	≤ 3W	>90%	Amber
Power Off (120VAC)	--	--	--	≤ 1W	>98%	Off

This display is ENERGY STAR®-compliant .



* Zero power consumption in OFF mode can only be achieved by disconnecting the mains cable from the display.

ENERGY STAR® is a U.S. registered mark. As an ENERGY STAR® Partner, DELL has determined that this product meets the ENERGY STAR® guidelines for energy efficiency.

Pin Assignments

15-pin D-sub connector

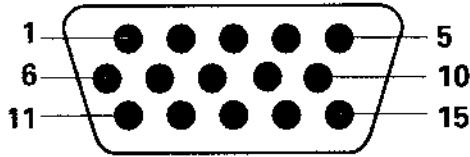

Pin Number	15-Pin Side of the Signal Cable
1	Video-Red
2	Video-Green
3	Video-Blue
4	GND
5	Self-test
6	GND-R
7	GND-G
8	GND-B
9	+5V Supply
10	GND-sync
11	GND
12	SDA
13	H-sync
14	V-sync
15	SCL

24 pin DVI-D connector

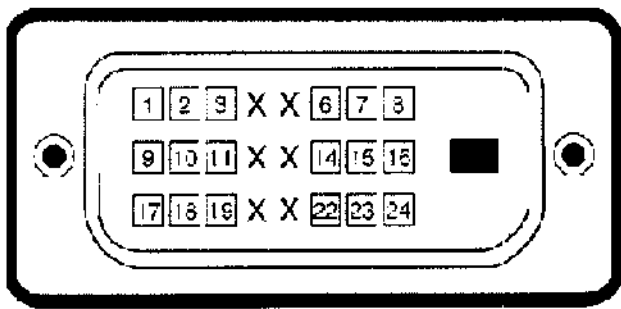

Pin Number	24-Pin Side of the Signal Cable
1	TMDS Data2-
2	TMDS Data2+
3	TMDS Data 2/4 Shield
4	TMDS Data4-
5	TMDS Data4+
6	DDC Clock
7	DDC Data
8	Analog Vertical Sync
9	TMDS Data1-
10	TMDS Data1+
11	TMDS Data 1/3 Shield
12	TMDS Data3-
13	TMDS Data3+
14	+5V Power
15	Ground(Return for +5V, H sync and V sync)
16	Hot Plug Detect
17	TMDS Data 0-
18	TMDS Data0+
19	TMDS Data 0/5 Shield
20	TMDS Data 5-
21	TMDS Data5+
22	TMDS Clock Shield
23	TMDS Clock+
24	TMDS Clock-

Plug and Play Capability

You can install the display in any Plug and Play-compatible system. The display automatically provides the computer system with its Extended Display Identification Data (EDID) using Display Data Channel (DDC) protocols so the system can configure itself and optimize the display settings. If desired, the user can select different settings.

Front View: Dell™ 1800FP Color Display User's Guide

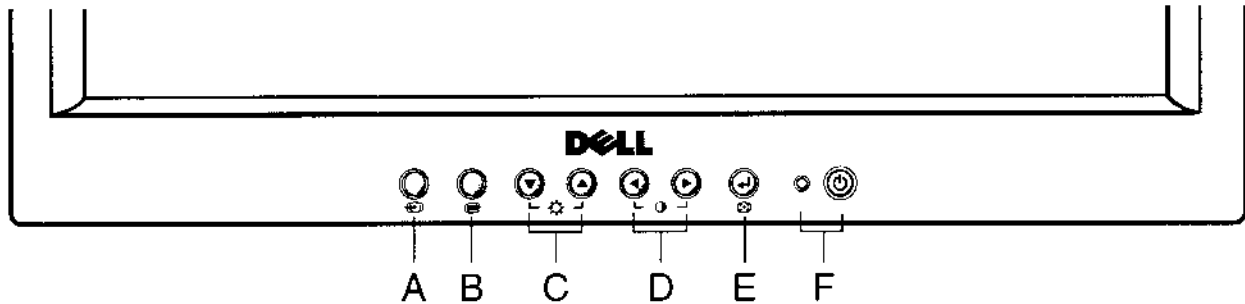

A. Input selection button



Use this button to make Dsub or DVI connector active. This feature is used when two computers are connected to the display. The default setting is Dsub.

B. Menu buttons



Use this button to enter or exit the On Screen Display.

C. Up/down arrow buttons

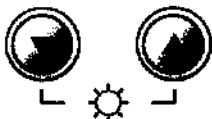

Select between OSD items and activates "Hot key" function for brightness adjustment.

D. Left/Right arrow buttons

Use these buttons to choose or adjust items in the On Screen Display and activates Hot Key function for



contrast adjustment.

E. Select/Auto button



- Use this button to enter a selection in the On Screen Display.
- Automatically adjust vertical position, horizontal position, pixel clock and phase.

F. Power button and LED indicator



Turn the display on/off and indicate the status of power management.

[Back to Contents Page](#)

Back View: Dell™ 1800FP Color Display User's Guide

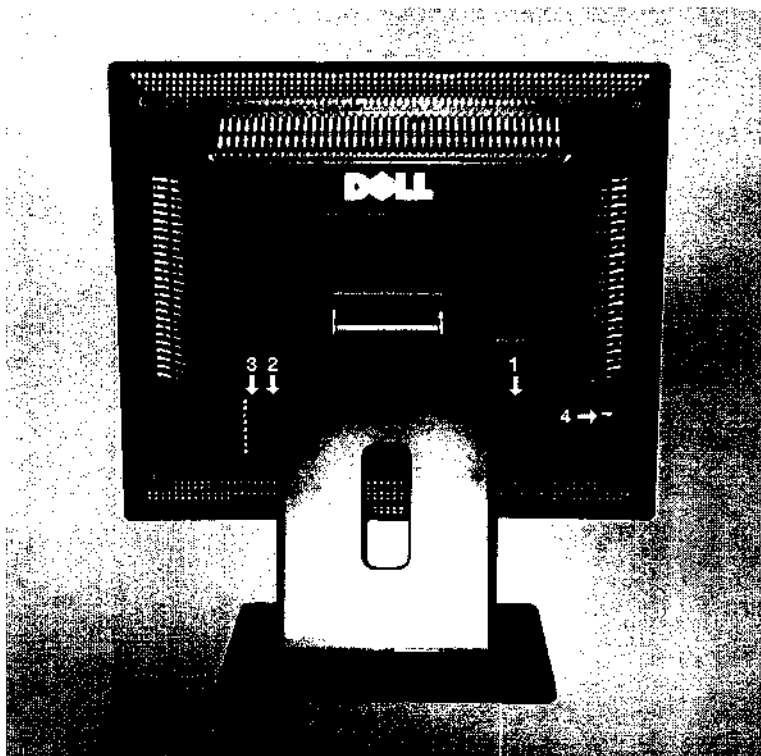

- 1. Power connector
 - 2. 15-pin D-sub input
 - 3. DVI-D digital input
 - 4. Kensington lock
-

Bottom View: Dell™ 1800FP Color Display User's Guide

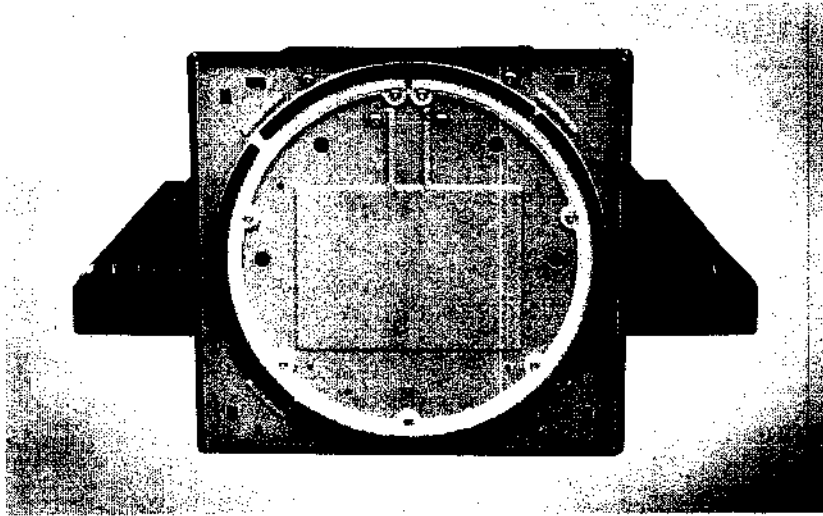

The base is attached when the display is shipped and can be removed.

Side View: Dell™ 1800FP Color Display User's Guide

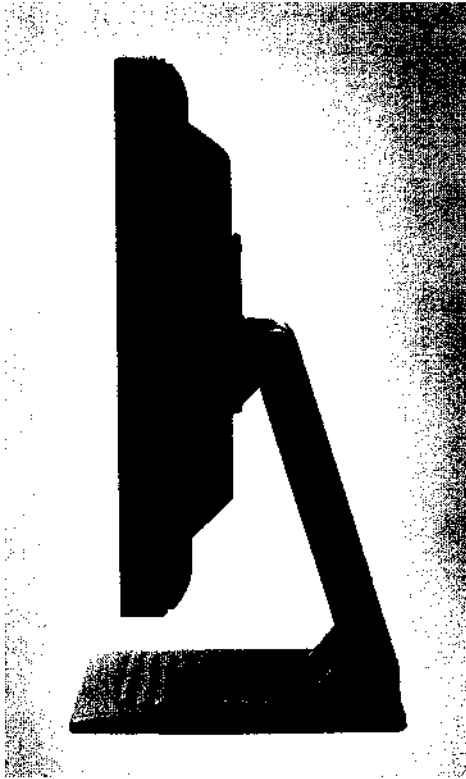

[Back to Contents Page](#)

Setup: Dell™ 1800FP Color Display User's Guide

[Tilt/Swivel Base](#)

[Attaching the Cables](#)

[Positioning the Display](#)

[Maintenance](#)

[Back to Contents Page](#)

Tilt/Swivel Base: Dell™ 1800FP Color Display User's Guide

Tilt/Swivel Base

With the Tilt/ Swivel base, you can tilt and/or swivel the display for the most comfortable viewing angle.

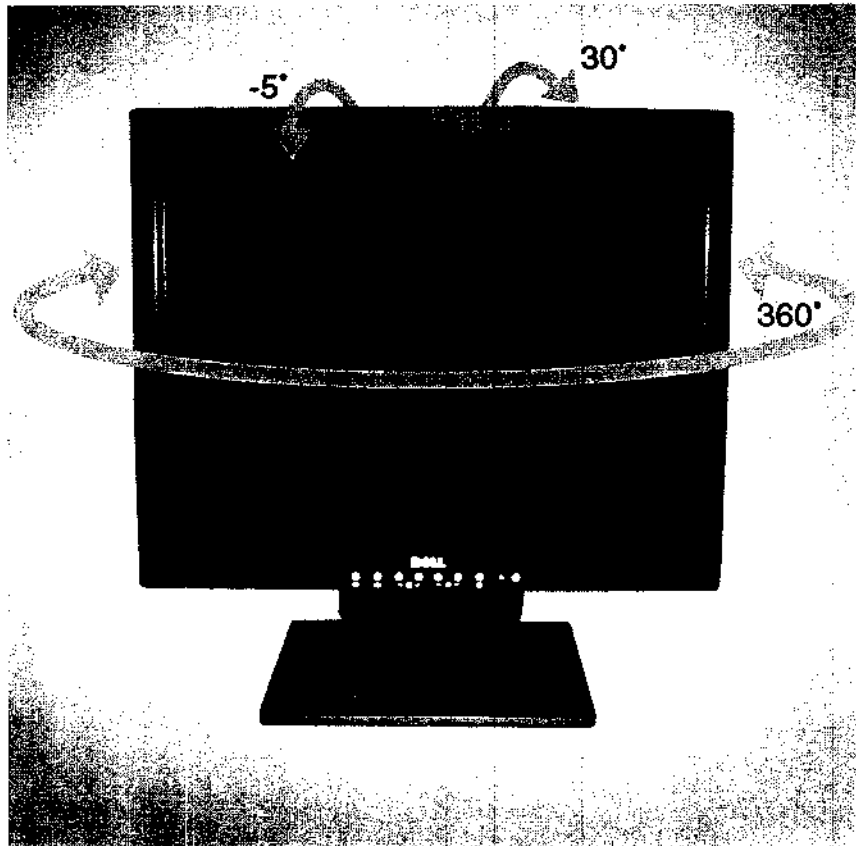

 **NOTE:** The removable base is attached when the display is shipped.

Attaching the Cables: Dell™ 1800FP Color Display User's Guide

Cable Connections On Back of Display and Computer

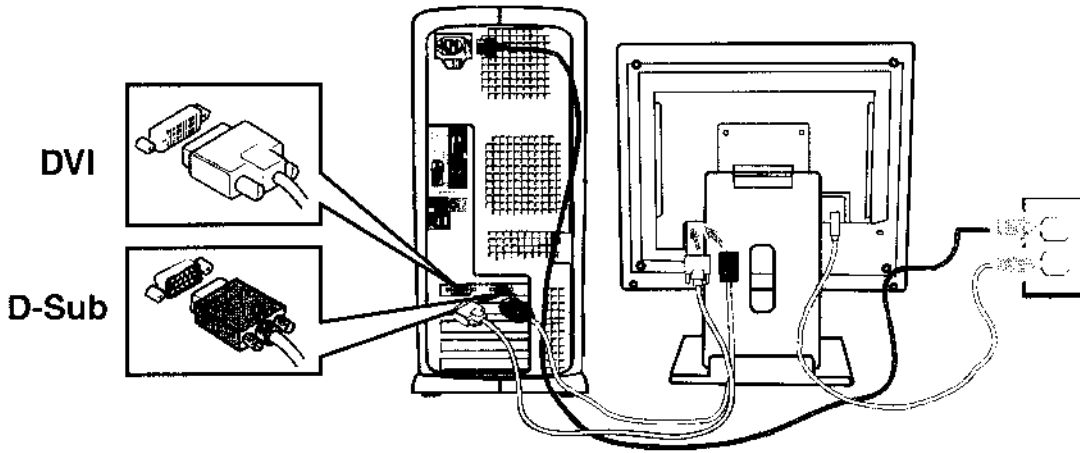

1. Turn off your computer and unplug its power cable.
2. Connect either the white (digital DVI-D) or the blue (analog D-SUB) display connector cable to the corresponding video port on the back of your computer. **Do not use both cables on the same PC.** The only case in which both cables can be used is if they are connected to two different PCs with appropriate video systems. (The graphics are for illustration only. System appearance may vary).
3. Connect the power cable for your display to the power plug on the back of the display.
4. Plug the power cables of your computer and your display into a nearby outlet.
5. Turn on your display and computer.

If your display displays an image, installation is complete. If it does not display an image, see [Troubleshooting](#).

Positioning the Display: Dell™ 1800FP Color Display User's Guide

Consider the following environmental factors when you are deciding how to position the display:

- Remove all electronic devices such as radios, fans, clocks, and telephones that are within 3 feet away of the display.
-

Maintenance: Dell™ 1800FP Color Display User's Guide



WARNING: To avoid risk of electric shock, do not disassemble the display cabinet. Users cannot service the display. User maintenance is restricted to cleaning.



NOTE: Before cleaning the display, unplug it from the electrical outlet.

- To clean your antistatic screen, lightly dampen a soft, clean cloth with water. If possible, use a special screen-cleaning tissue or solution suitable for the antistatic coating.
 - To clean your Midnight Gray display cabinet, avoid using detergent of any kind. Detergent leaves a milky film on plastics; particularly the darker colored ones. It is best to use a lightly water dampened warm cloth to clean the cabinet.
 - White powder substance, due to shipping, may appear on the plastic or near bezel edge. If you observe this, simply wipe it off.
 - Darker color plastics may scratch and shows white scuff marks more than lighter-colored display. Handle your Midnight Gray display with care.
-

Setting the Optimal Resolution: Dell™ 1800FP Color Display User's Guide

For optimal display performance while using the Microsoft® Windows® operating systems, set the display resolution to 1280 x 1024 pixels by performing the following steps:

1. Right-click in a blank area of the desktop (any part of the screen where there are no icons) and click on **Properties**
 2. Click the **Settings** tab.
 3. In the **Resolution** area, move the sidebar to 1280 by 1024 pixels. Then click **OK**.
-



Controls and Indicators: Dell™ 1800FP Color Display User's Guide

Overview • On Screen Display (OSD) Menu System • Automatic Save • OSD Warning Messages • LED Indicators

Overview

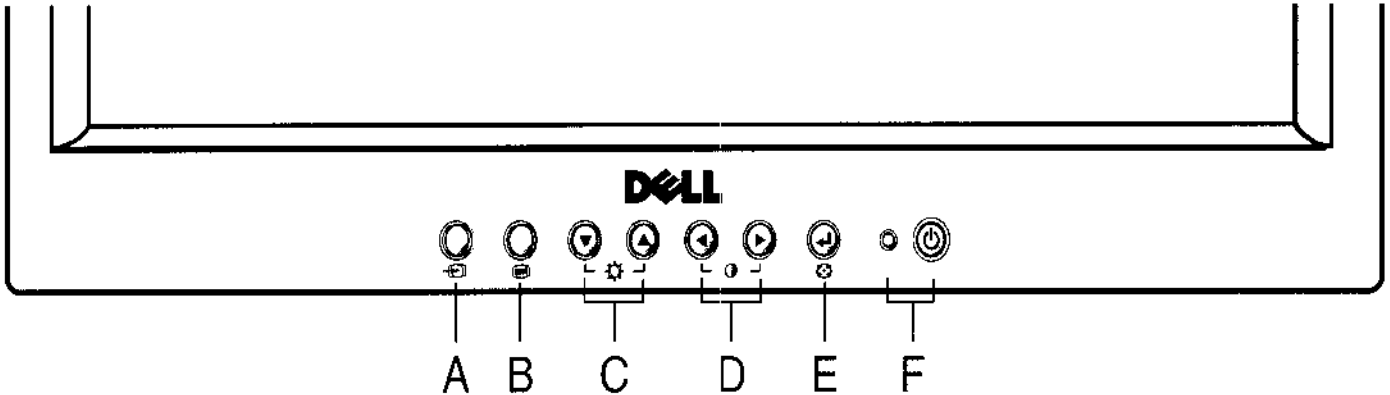
Use the control buttons on the front of the display to adjust the characteristics of the image being displayed. As you use these buttons to adjust the controls, an on-screen display (OSD) shows their numeric values as they change.

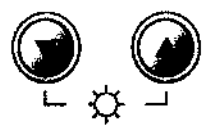

<p>A. Input selection button</p> 	<p>Use this button to make D-sub or DVI connector active. This feature is used when two computers are connected to the display. The default setting is D-sub.</p>
<p>B. Menu button</p> 	<p>Use this button to enter or exit the On Screen Display. See access the Menu system.</p>
<p>C. Up/down arrow buttons</p> 	<p>Selects between OSD items and activates the "Hot key" function for the brightness adjustment.</p>
<p>D. Left/Right arrow buttons</p>	<p>Chooses or adjusts items in the On Screen Display and activates Hot Key function for the contrast adjustment.</p>



E. Select/Auto button



Automatically adjust vertical position, horizontal position, pixel clock and phase. For best results, use this button when there is a full screen of detailed information, such as fine text. The following dialog will appear as the display self-adjusts to the current input:



See Auto adjustment.

 *Note: Auto Adjust will not occur if you press the button while there are no active video input signals, or attached cables.*

Auto adjustment will also not function in the DVI mode. This is normal.

F. Power button and LED indicator



Turn the display on/off and indicate the status of power management. The power indicator lights steady green while the display function normally. The LED is steady amber for DPMS. See [Power management mode](#).

On Screen Display (OSD) Menu System

Direct-Access Functions

Function	Adjustment Method
<p>Auto adjustment:</p> 	<p>Even though your computer system can recognize your new flat panel display on startup, the 'Auto Adjustment' function will optimize the display settings for use with your particular analog D-sub graphics adapter. Auto Adjustment can be accessed through the OSD via the Image Settings submenu pictured at left or, you may use the direct access instructions below:</p> <ol style="list-style-type: none"> 1. Turn on your computer and display. 2. Push the 'Select/Auto' button (E) to activate the Auto adjustment function.

3. When finished, the pixel clock and phase should be adjusted to their optimal settings.

Brightness:

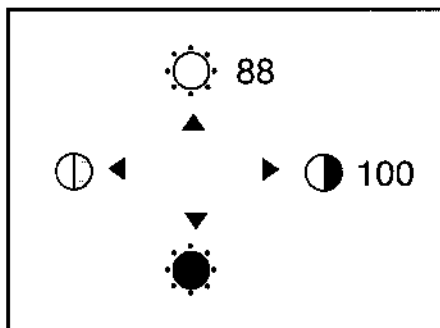

The Brightness function adjusts the luminance of the flat panel.

With the menu off, push the up(or down) arrow button to display the Brightness adjustment menu.

Adjust Brightness first, then adjust Contrast only if further adjustment is necessary.

- ▲increase luminance
- ▼decrease luminance

Contrast:

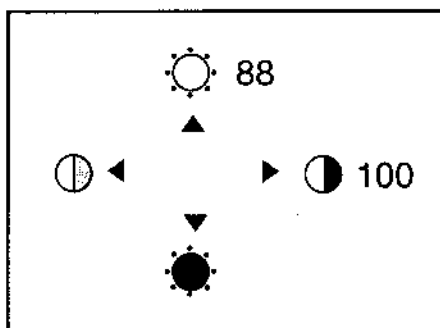

The Contrast function adjusts the degree of difference between darkness and lightness on the display screen.

With the menu off, push the left(or right) arrow button to display the Contrast adjustment menu.

- ◀decrease the contrast
- ▶increase the contrast

Controls Locked/Unlocked: Menu and, ▶



This function allows you to secure the current control settings, so that they cannot be inadvertently changed. Press and hold the MENU button and ▶button for 3 seconds: the message "CONTROLS LOCKED" appears. You can unlock the OSD controls at any time by pushing the MENU button and ▶button for 3 seconds: the message "CONTROLS UNLOCKED" will appear.

Accessing the Menu System

1. With the menu off, push the MENU button to open the OSD system and display the main features menu.

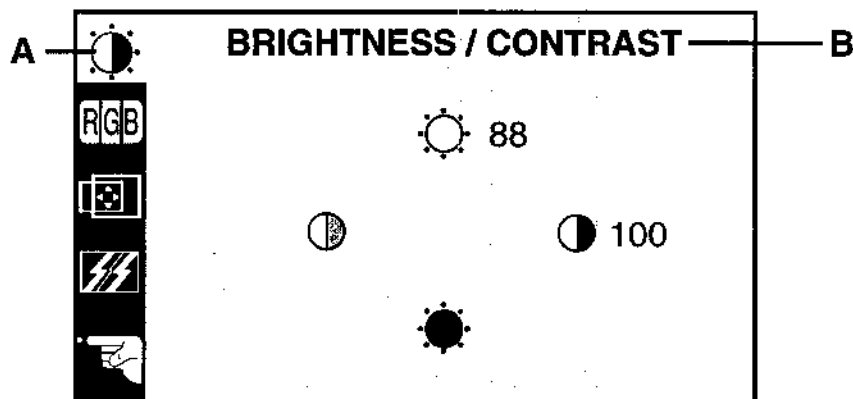

A	Sub-menu icon	B	Sub-menu name
----------	---------------	----------	---------------

- The OSD main menu has 5 sub-menus including "Brightness/Contrast", "Color", "Position", "Tracking" and "Setup". Push the up and down arrow buttons to move between the function icons. As you move from one icon to another, the function name is highlighted to reflect the function or group of functions (sub-menus) represented by that icon. See the table below for a complete list of all the functions available for the display.
- Push the MENU button once to activate the highlighted function; then use the left and right buttons or the up and down arrow buttons, according to the indicators on the menu, to make your changes.
- Push the Menu button once to return to the main menu to select another function or push the Menu button two or three times to exit from the OSD.

Main Menu Mode

Grouped by functions, the OSD offers 5 major functions in Main Menu for making adjustments: "Brightness/Contrast", "Color", "Position", "Tracking" and "Setup". The following describes the contents of each function and how you can make adjustments.

Menu	Icon	Adjustment
		Brightness: Adjust the brightness of the screen. ▲increase luminance ▼decrease luminance
		Contrast: Adjust the contrast of the screen. ◀decrease the contrast ▶increase the contrast
	9300K	This preset color temperature is more
	sRGB(6500K)	This preset color temperature is more
	RED GREEN BLUE	User Preset: You can adjust the Red, Green and Bl independently to your preference. ◀decrease the brightness of the speci ▶increase the brightness of the specif

When you enter the Color Settings submenu, this page will show up if current input is D-sub or DVI-D. Color temperature is a measure of the 'warmth' of the image colors (red/green/blue). The available range is between 6500 to 9300K. You can select one of the 2 Preset Color temperatures or utilize the RED/GREEN/BLUE' option to customize the color settings to your preference.

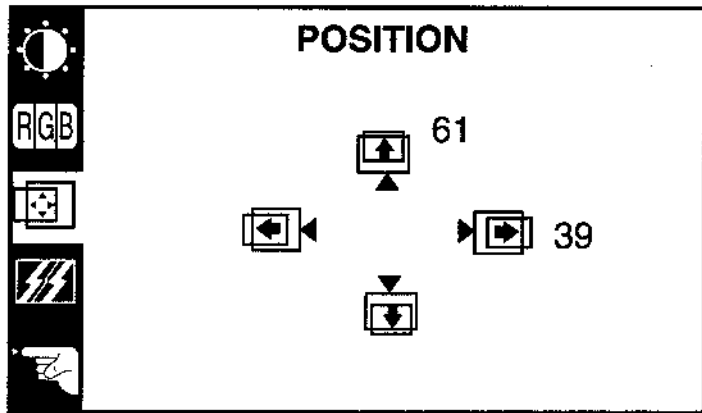

Positioning moves the viewing area around on the display screen. When making changes to either the 'Horizontal' or 'Vertical' settings, no changes will occur to the size of the viewing area. The image will be shifted in response to your selection/change.



Horizontal Position:
Adjust the horizontal position of the display.

- ◀ moves the screen left
- ▶ moves the screen right



Vertical Position:
Adjust the vertical position of the display.

- ▼ moves the screen down
- ▲ moves the screen up

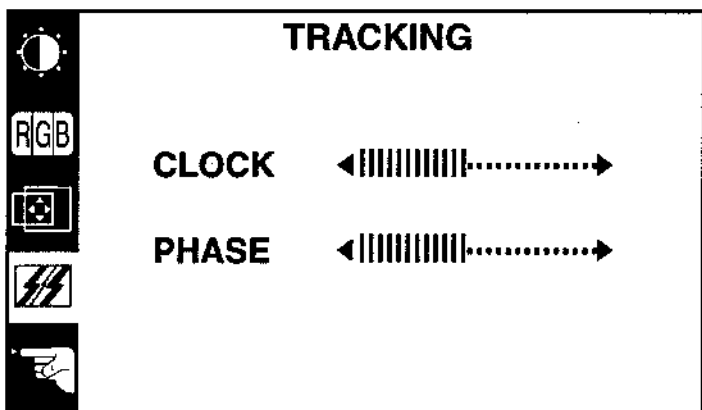

The Clock and Phase adjustments allow you to more closely adjust your display to your preference. These settings are accessed through the main OSD menu, by selecting 'Tracking'.

If satisfactory results are not obtained using the Phase adjustment, use the Clock adjustment and then use Phase again.

 *Note: This function may change the width of the display image. Use the Horizontal function of the Position menu to center the display image on the screen.*

Clock:
This function only applies to D-sub input. When a digital signal is input to the display, it will be automatically optimized. In this case, an abnormal image displayed on the screen. You can adjust the sampling interval manually through Pixel Clock function.

- ◀ decrease the sampling interval
- ▶ increase the sampling interval

Phase:
Just like Pixel Clock function, you can adjust the sampling phase. This is a fine tracking function.

- ◀ decrease phase shift of sampling signal
- ▶ increase phase shift of sampling signal

Early Production

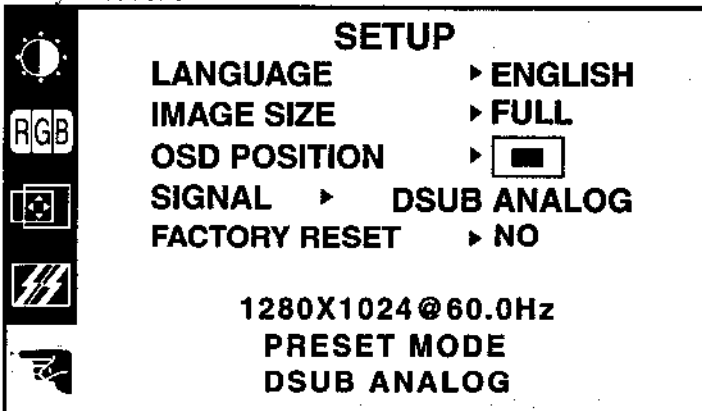

Later Production

Language:
Selects the menu language.

Image Size:
This function displays the image in its original size so it fits the full screen panel.

OSD Position:
Adjusts the position of the OSD window on the screen.

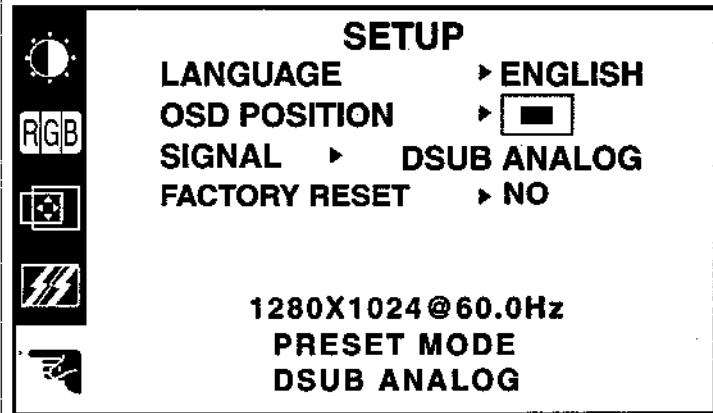

Signal:
Selects DSUB ANALOG or DVI DIGIT active input. This feature is used when computers are connected to the display. The display automatically detects the proper input video source is connected.

Factory Reset:
Returns the original factory settings. Press  button to activate.

Automatic Save

With the OSD open, if you make an adjustment and then either proceed to another menu or exit the OSD, the display automatically saves any adjustments you have made. If you have made *no* adjustments, the on-screen menu disappears and the display does not save any new settings.

OSD Warning Messages

Self-Test Feature Check (STFC)



The floating SELF DIAGNOSTICS dialog will appear on-screen (against a black background) under the following conditions:

1. If the display is powered on with no signal cable attached, with any of the inputs selected.
2. If the signal cable is detached while the monitor is working normally with either the D-sub or DVI-d input selected.

The display should stay in STFC mode until the input selection button is pressed to select input source which is active, or the cable is re-attached.

In Power Save Mode

■ **DSUB ANALOG** ■
■
■ **POWER SAVING MODE** ■

When the computer system sends DPMS (Display Power Management Signaling) signals for display power management, the display will show the message of "Power Saving Mode" for 10 seconds then enter power saving mode. This occurs when the DB15 analog or DVI-D digital input is connected and selected, but the computer source has gone inactive. While the display is in power saving mode, the screen will remain black. You can press any key or move mouse to reactivate the display.

Input Signal Out of Range

■ **INPUT SIGNAL** ■
■
■ **OUT OF RANGE** ■

POWER MANAGEMENT 17SEC

This means that the display cannot synchronize with the signal that it is receiving from the computer. Either the signal frequency is too high or too low for the display to use. See Specifications for the Horizontal and Vertical scan ranges addressable by this display.

Sometimes, no warning message appears, but the screen is blank, which could also indicate that the display is not synchronizing with the computer.

LED Indicators

Display State	LED state
On	Power management indicator is green
DPMS	Power management indicator is amber

See Troubleshooting for more information.

[Back to Contents Page](#)

Troubleshooting: Dell™ 1800FP Color Display User's Guide

Display Specific Troubleshooting • Common Problems • Product Specific Problems

Display Specific Troubleshooting

Self-Test Feature Check (STFC)

Your display provides a self-test feature that allows you to check whether your display is functioning properly. If your display and computer are properly connected but the display screen remains dark, run the display self-test by performing the following steps:

1. Turn off both your computer and the display.
2. Unplug the video cable from the back of the computer.
3. Turn on the display.

If the display is functioning properly, you will see the STFC pattern.

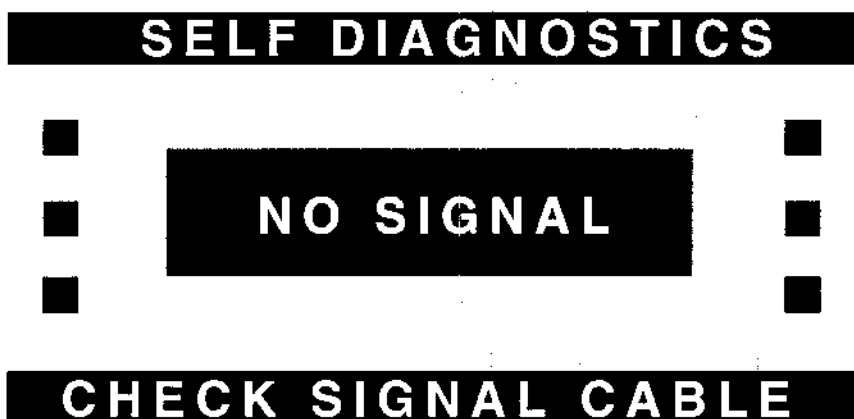

4. While in self-test mode, the power management indicator remains green and the STFC pattern scroll through the screen.
5. Turn off your display and reconnect the video cable; then turn on both your computer and the display.

If your display screen still remains dark after you use the previous procedure, check your video controller and computer system; **your display is functioning properly.**

Power Saving Mode

When the computer system is under power saving mode, the display will show the message of "Power Saving Mode". Then press any key to reactivate the PC system.

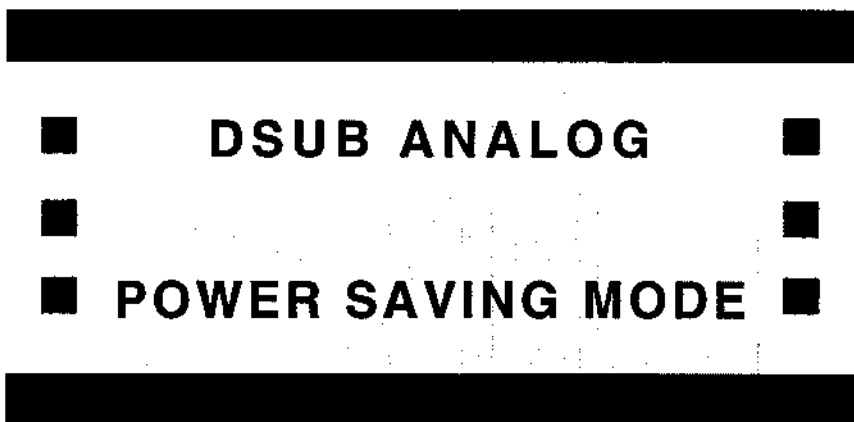

Common Problems

The following table contains general information about common display problems you might encounter.

COMMON SYMPTOMS	WHAT YOU SEE	POSSIBLE SOLUTIONS
No Video/ Power LED off	No picture, display's dead.	<ul style="list-style-type: none"> • Check connection integrity • Electric outlet verification
No Video/ Power LED on	No picture or no brightness	<ul style="list-style-type: none"> • Increase brightness & contrast controls • Perform display self test feature check • Check for bent or broken pins on the signal cable • Make sure the correct video input source is selected
Poor Focus	Picture is fuzzy, blurry or ghosting	<ul style="list-style-type: none"> • Push Auto key • Adjust Phase and Clock controls via OSD • Eliminate video extension cables • Perform display reset • Decrease brightness & contrast controls • Make sure the display resolution is set to 1280x1024@60Hz
Shaky/Jittery Video	Wavy picture or fine movement	<ul style="list-style-type: none"> • Push Auto key • Adjust Phase and Clock controls via OSD • Perform Factory Reset
Missing Pixels	LCD screen has spots	<ul style="list-style-type: none"> • Cycle power on-off • These are some pixels that are permanently off and is normal in LCD technology
Stuck-on Pixels	LCD screen has bright spots	<ul style="list-style-type: none"> • Cycle power on-off • These are some pixels that are permanently on and is normal in LCD technology
Brightness Problems	Picture too dim or too bright	<ul style="list-style-type: none"> • Perform display reset • Adjust brightness & contrast controls
Geometric Distortion	Screen not centered correctly	<ul style="list-style-type: none"> • Push Auto key • Adjust the centering controls • Perform Factory Reset • Ensure display is in proper video mode
Horizontal/Vertical Lines	Screen has one or more lines	<ul style="list-style-type: none"> • Perform Factory Reset • Adjust Phase and Clock controls via OSD • Push Auto key • Perform display self test feature check • Check for bent or broken pins
Sync Problems	Screen is scrambled or appears torn	<ul style="list-style-type: none"> • Adjust Phase and Clock controls via OSD • Push Auto key • Perform display self test feature check • Check for bent or broken pins • If using Microsoft® Windows®, boot up in the "safe mode"

LCD Scratched	Screen has scratches or smudges	<ul style="list-style-type: none"> • Turn display off and clean the screen
Safety Related Issues	Visible signs of smoke or sparks	<ul style="list-style-type: none"> • Do not perform any troubleshooting steps • Display needs to be replaced
Intermittent Problems	Display malfunctions on & off	<ul style="list-style-type: none"> • Ensure display is in proper video mode • Ensure video cable connection is secure • Perform Factory Reset • Perform display self test feature check

Product Specific Problems

SPECIFIC SYMPTOMS	WHAT YOU SEE	POSSIBLE SOLUTIONS
Cannot adjust the display with the buttons on the front panel	OSD does not appear on the screen	<ul style="list-style-type: none"> • Make sure the controls are not locked. See Using the Monitor section for the Lock feature. • Disconnect AC power from the display, wait five minutes and then re-connect AC power
Screen image is too small	Image is centered on screen, but does not fill entire viewing area	<ul style="list-style-type: none"> • Adjust the Image Size feature via the OSD and select Full. This feature is located under Image Settings

[Back to Contents Page](#)

Regulatory: Dell™ 1800FP Color Display User's Guide

[Electric and Magnetic Fields](#) • [Energy Efficiency](#) • [Federal Communications Commission \(FCC\) Notice \(U.S. Only\)](#) • [CE Conformity Notice\(for Europe\)](#) • [Canadian Regulatory Information \(Canada Only\)](#) • [EN 55022 Compliance \(Czech Republic Only\)](#) • [VCCI Class 2 Notice \(Japan Only\)](#) • [MIC Notice \(South Korea Only\)](#) • [Polish Center for Testing and Certification Notice](#) • [NOM Information \(Mexico Only\)](#) • [BSMI Notice](#)

[Dell Computer Corporation's Environmental Program](#) • [Regulatory Listing](#)

Electric and Magnetic Fields

Early Production : TCO95

Later Production : TCO99



Congratulations!

You have just purchased a TCO'95 approved and labeled product! Your choice has provided you with a product developed for professional use. Your purchase has also contributed to reducing the burden on the environment and also to the further development of environmentally adapted electronics products.

Why do we have environmentally labeled computers?

In many countries, environmental labeling has become an established method for encouraging the adaptation of goods and services to the environment. The main problem, as far as computers and other electronics equipment are concerned, is that environmentally harmful substances are used both in the products and during their manufacture. Since it is not so far possible to satisfactorily recycle the majority of electronics equipment, most of these potentially damaging substances sooner or later enter nature.

There are also other characteristics of a computer, such as energy consumption levels, that are important from the viewpoints of both the work (internal) and natural (external) environments. Since all methods of electricity generation have a negative effect on the environment (e.g. acidic and climate-influencing emissions, radioactive waste), it is vital to save energy. Electronics equipment in offices is often left running continuously and thereby consumes a lot of energy.

What does labeling involve?

This product meets the requirements for the TCO'95 scheme which provides for international and environmental labeling of personal computers. The labeling scheme was developed as a joint effort by the TCO (The Swedish Confederation of Professional Employees), Svenska Naturskyddsforeningen (The Swedish Society for Nature Conservation) and Statens Energimyndighet (The Swedish National Energy Administration).

Approval requirements cover a wide range of issues: environment, ergonomics, usability, emission of electric and magnetic fields, energy consumption and electrical and fire safety.

The environmental demands impose restrictions on the presence and use of heavy metals, brominated and chlorinated flame retardants, CFCs (freons) and chlorinated solvents, among other things. The product must be prepared for recycling and the manufacturer is obliged to have an environmental policy which must be adhered to in each country where the company implements its operational policy.

The energy requirements include a demand that the computer and/or display, after a certain period of inactivity, shall reduce

its power consumption to a lower level in one or more stages. The length of time to reactivate the computer shall be reasonable for the user.

Labeled products must meet strict environmental demands, for example, in respect of the reduction of electric and magnetic fields, physical and visual ergonomics and good usability.

Below you will find a brief summary of the environmental requirements met by this product. The complete environmental criteria document may be ordered from:

TCO Development

SE-114 94 Stockholm, Sweden

Fax: +46 8 782 92 07

Email (Internet): development@tco.se

Current information regarding TCO'95 approved and labelled products may also be

obtained via the Internet, using the address: <http://www.tco-info.com/>

Environmental requirements

Flame retardants

Flame retardants are present in printed circuit boards, cables, wires, casings and housings. Their purpose is to prevent, or at least to delay the spread of fire. Up to 30% of the plastic in a computer casing can consist of flame retardant substances. Most flame retardants contain bromine or chloride, and those flame retardants are chemically related to another group of environmental toxins, PCBs. Both the flame retardants containing bromine or chloride and the PCBs are suspected of giving rise to severe health effects, including reproductive damage in fish-eating birds and mammals, due to the bio-accumulative* processes. Flame retardants have been found in human blood and researchers fear that disturbances in foetus development may occur.

The relevant TCO'95 demand requires that plastic components weighing more than 25 grams must not contain flame retardants with organically bound bromine or chlorine. Flame retardants are allowed in the printed circuit boards since no substitutes are available.

Cadmium**

Cadmium is present in rechargeable batteries and in the colour-generating layers of certain computer displays. Cadmium damages the nervous system and is toxic in high doses. The relevant TCO'95 requirement states that batteries, the colour-generating layers of display screens and the electrical or electronics components must not contain any cadmium.

Mercury**

Mercury is sometimes found in batteries, relays and switches. It damages the nervous system and is toxic in high doses. The relevant TCO'95 requirement states that batteries may not contain any mercury. It also demands that mercury is not present in any of the electrical or electronics components associated with the labelled unit.

CFCs (freons)

The relevant TCO'95 requirement states that neither CFCs nor HCFCs may be used during the manufacture and assembly of the product. CFCs (freons) are sometimes used for washing printed circuit boards. CFCs break down ozone and thereby damage the ozone layer in the stratosphere, causing increased reception on earth of ultraviolet light with e.g. increased risks of skin cancer (malignant melanoma) as a consequence.

Lead**

Lead can be found in picture tubes, display screens, solders and capacitors. Lead damages the nervous system and in higher doses, causes lead poisoning. The relevant TCO'95 requirement permits the inclusion of lead since no replacement has yet been developed.

* *Bio-accumulative is defined as substances which accumulate within living organisms*

** *Lead, Cadmium and Mercury are heavy metals which are Bio-accumulative.*



Congratulations!

You have just purchased a TCO'99 approved and labelled product! Your choice has provided you with a product developed for professional use. Your purchase has also contributed to reducing the burden on the environment and also to the further development of environmentally adapted electronics products.

Why do we have environmentally labeled computers?

In many countries, environmental labelling has become an established method for encouraging the adaptation of goods and services to the environment. The main problem, as far as computers and other electronics equipment are concerned, is that environmentally harmful substances are used both in the products and during their manufacture. Since it is not so far possible to satisfactorily recycle the majority of electronics equipment, most of these potentially damaging substances sooner or later enter nature.

There are also other characteristics of a computer, such as energy consumption levels, that are important from the viewpoints of both the work (internal) and natural (external) environments. Since all methods of electricity generation have a negative effect on the environment (e.g. acidic and climate-influencing emissions, radioactive waste), it is vital to save energy. Electronics equipment in offices is often left running continuously and thereby consumes a lot of energy.

What does labelling involve?

This product meets the requirements for the TCO'99 scheme which provides for international and environmental labelling of personal computers. The labelling scheme was developed as a joint effort by the TCO (The Swedish Confederation of Professional Employees), Svenska Naturskyddsforeningen (The Swedish Society for Nature Conservation) and Statens Energimyndighet (The Swedish National Energy Administration).

Approval requirements cover a wide range of issues: environment, ergonomics, usability, emission of electric and magnetic fields, energy consumption and electrical and fire safety.

The environmental demands impose restrictions on the presence and use of heavy metals, brominated and chlorinated flame retardants, CFCs (freons) and chlorinated solvents, among other things. The product must be prepared for recycling and the manufacturer is obliged to have an environmental policy which must be adhered to in each country where the company implements its operational policy.

The energy requirements include a demand that the computer and/or display, after a certain period of inactivity, shall reduce its power consumption to a lower level in one or more stages. The length of time to reactivate the computer shall be reasonable for the user.

Labelled products must meet strict environmental demands, for example, in respect of the reduction of electric and magnetic fields, physical and visual ergonomics and good usability. Below, you will find a brief summary of the environmental requirements met by this product. The complete environmental criteria document may be ordered from:

TCO Development

SE-114 94 Stockholm, Sweden

Fax: +46 8 782 92 07

Email (Internet): development@tco.se

Current information regarding TCO'99 approved and labelled products may also be obtained via the Internet, using the address: <http://www.tco-info.com/>

Environmental requirements

Flame retardants

Flame retardants are present in printed circuit boards, cables, wires, casings and housings. Their purpose is to prevent, or at least to delay the spread of fire. Up to 30% of the plastic in a computer casing can consist of flame retardant substances. Most flame retardants contain bromine or chloride, and those flame retardants are chemically related to another group of environmental toxins, PCBs. Both the flame retardants containing bromine or chloride and the PCBs are suspected of giving rise to severe health effects, including reproductive damage in fish-eating birds and mammals, due to the bioaccumulative* processes. Flame retardants have been found in human blood and researchers fear disturbances in foetus development may occur.

The relevant TCO'99 demand requires that plastic components weighing more than 25 grams must not contain flame retardants with organically bound bromine or chlorine. Flame retardants are allowed in the printed circuit boards since no substitutes are available.

Cadmium**

Cadmium is present in rechargeable batteries and in the colour-generating layers of certain computer displays. Cadmium damages the nervous system and is toxic in high doses. The relevant TCO'99 requirement states that batteries, the colour-generating layers of display screens and the electrical or electronics components must not contain any cadmium.

Mercury**

Mercury is sometimes found in batteries, relays and switches. It damages the nervous system and is toxic in high doses. The relevant TCO'99 requirement states that batteries may not contain any mercury. It also demands that mercury is not present in any of the electrical or electronics components associated with the labelled unit.

CFCs (freons)

The relevant TCO'99 requirement states that neither CFCs nor HCFCs may be used during the manufacture and assembly of the product. CFCs (freons) are sometimes used for washing printed circuit boards. CFCs break down ozone and thereby damage the ozone layer in the stratosphere, causing increased reception on earth of ultraviolet light with e.g. increased risks of skin cancer (malignant melanoma) as a consequence.

Lead**

Lead can be found in picture tubes, display screens, solders and capacitors. Lead damages the nervous system and in higher doses, causes lead poisoning. The relevant TCO'99 requirement permits the inclusion of lead since no replacement has yet been developed.

*** Bio-accumulative is defined as substances which accumulate within living organisms**

**** Lead, Cadmium and Mercury are heavy metals which are Bio-accumulative.**

Energy Efficiency



The proper operation of the function requires a computer with VESA DPMS power management capabilities. When used with a computer equipped with VESA DPMS, the display is ENERGY STAR-compliant.

As an ENERGY STAR Partner, Dell Computer Corporation has determined that this product meets the ENERGY STAR guidelines for energy efficiency.

Federal Communications Commission (FCC) Notice (U.S. Only)

⚠ WARNING: This equipment has been tested and found to comply with the limits for a Class B digital device, pursuant to Part 15 of the FCC Rules. These limits are designed to provide reasonable protection against harmful interference in a residential installation. This equipment generates, uses, and can radiate radio frequency energy and, if not installed and used in accordance with the instructions, may cause harmful interference to radio communications. However, there is no guarantee that interference will not occur in a particular installation. If this equipment does cause harmful interference to radio or television reception, which can be determined by turning the equipment off and on, the user is encouraged to try to correct the interference by one or more of the following measures:

- Reorient or relocate receiving antenna.
- Increase the separation between the equipment and receiver.
- Connect the equipment into an outlet on a circuit different from that to which the receiver is connected.
- Consult the dealer or an experienced radio/TV technician for help.

This device complies with Part 15 of the FCC rules. Operation is subject to the following two conditions:

- This device may not cause harmful interference.
- This device must accept any interference received including interference that may cause undesired operation.

Instructions to Users: This equipment complies with the requirements of FCC (Federal Communication Commission) equipment provided that following conditions are met.

1. Power cable: Shielded power cable must be used.
2. Video inputs: The input signal amplitude must not exceed the specified level.

⚠ CAUTION: Changes or modifications not expressly approved by the party responsible for compliance could void the user's authority to operate the equipment.

CE Conformity Notice (for Europe)

Products with the "CE" Marking comply with the EMC Directive(89/336/EEC) and LOW VOLTAGE Directive (73/23/EEC) issued by the Commission of the European Community.

Compliance with these directives implies conformity to the following European Norms :

- EN 55022 ; Radio Frequency Interference
 - EN 50082-1:1992 ; Electromagnetic Immunity
 - EN 60555-2 ; Power Line Harmonics
 - EN 60555-3 ; Voltage Fluctuations
 - EN 60950 ; Product Safety
-

Canadian Regulatory Information (Canada Only)

This digital apparatus does not exceed the Class B limits for radio noise emissions from digital apparatus set out in the Radio Interference Regulations of the Canadian Department of Communications.

Note that Canadian Department of Communications (DOC) regulations provide, that changes or modifications not expressly approved by Dell Computer Corporation could void your authority to operate this equipment.

This Class B digital apparatus meets all requirements of the Canadian Interference-Causing Equipment Regulations.

Cet appareil numerique de la classe B respecte toutes les exigences du Reglement sur le materiel brouilleur du Canada.

EN 55022 Compliance (Czech Republic Only)

This device belongs to category B devices as described in EN 55022, unless it is specifically stated that it is a category A device on the specification label. The following applies to devices in category A of EN 55022 (radius of protection up to 30 meters). The user of the device is obliged to take all steps necessary to remove sources of interference of telecommunication or other devices.

Pokud není na typovém štítku počítače uvedeno, že spadá do třídy A podle EN 55022, spadá automaticky do třídy B podle EN 55022. Pro zařízení zařazená do třídy A (chranné pásmo 30m) podle EN 55022 platí následující. Dojde-li k rušení telekomunikačních nebo jiných zařízení, je uživatel povinen provést taková opatření, aby rušení odstranil.

VCCI Class 2 Notice (Japan Only)

This equipment complies with the limits for a Class 2 digital device (devices used in or adjacent to a residential environment) and conforms to the standards for information technology equipment that are set by the Voluntary Control Council for Interference for preventing radio frequency interference in residential areas.



Class B ITE

この装置は、日本無線協会（VCCI）の基準に基づきクラスB（住宅環境で使用可能な）デジタル装置です。この装置が家庭環境で使用されることを目的としていますが、この装置がラジオやテレビジョン受信機に近接して使用されると、有害な干渉を引き起こす可能性があります。取扱説明書に従って正しい取扱いをお願いします。

MIC Notice (South Korea Only)

B Class Device

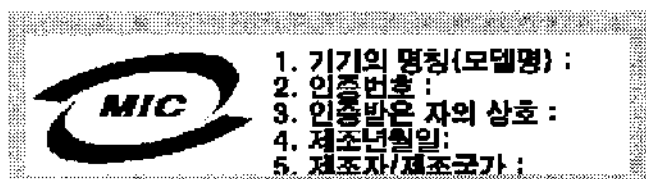

Please note that this device has been approved for nonbusiness purposes and may be used in any environment, including residential areas.

Polish Center for Testing and Certification Notice

The equipment should draw power from a socket with an attached protection circuit (a three-prong socket). All equipment that works together (computer, monitor, printer, and so on) should have the same power supply source.

The phasing conductor of the room's electrical installation should have a reserve short-circuit protection device in the form of a fuse with a nominal value no larger than 16 amperes (A).

To completely switch off the equipment, the power supply cable must be removed from the power supply socket, which should be located near the equipment and easily accessible.

A protection mark "B" confirms that the equipment is in compliance with the protection usage requirements of standards PN-

Wymagania Polskiego Centrum Badań i Certyfikacji

Urządzenie powinno być zasilane z gniazda z przyłączonymi obwodem ochronnym (gniazdo z kolkiem). Współpracujące ze sobą urządzenia (komputer, monitor, drukarka) powinny być zasilane z tego samego źródła.

Instalacja elektryczna pomieszczenia powinna zawierać w przewodzie fazowym rezerwa ochronę przed zwarciami, w postaci bezpiecznika o wartości znamionowej nie większej niż 16A (ampierów).

W celu całkowitego wyłączenia urządzenia z sieci zasilania, należy wyjąć wtyczkę kabla zasilającego z gniazda, które powinno znajdować się w pobliżu urządzenia i być łatwo dostępne.

Znak bezpieczeństwa "B" potwierdza zgodność urządzenia z wymaganiami bezpieczeństwa użytkownika zawartymi w PN-93/T-42107 i PN-89/E-06251.

Pozostałe instrukcje bezpieczeństwa

- Nie należy używać wtyczek adapterowych lub usuwać kolka obwodu ochronnego z wtyczki. Jeżeli konieczne jest użyć przedłużacza to należy użyć przedłużacza 3-żyłowego z prawidłowo połączonymi przewodami ochronnym.
- System komputerowy należy zabezpieczyć przed nagłymi, chwilowymi wzrostami lub spadkami napięcia, używając eliminatora przepięć, urządzenia dopasowującego lub bezaktywnego źródła zasilania.
- Należy upewnić się, aby nie nie leżało na kablach systemu komputerowego, oraz aby kable nie były umieszczone w miejscu, gdzie można byłoby na nie nakładać lub połykać się o nie.
- Nie należy rozlewać napojów ani innych płynów na system komputerowy.
- Nie należy wpychać żadnych przedmiotów do otworów systemu komputerowego, gdyż może to spowodować pożar lub porażenie prądem, poprzez zwarcie elementów wewnętrznych.
- System komputerowy powinien znajdować się z dala od grzejników i źródeł ciepła. Ponadto, nie należy blokować otworów wentylacyjnych. Należy unikać kładzenia luznych papierów pod komputer oraz umieszczenia komputera w ciasnym miejscu bez możliwości cyrkulacji powietrza wokół niego.

NOM Information (Mexico Only)

The following information is provided on the device(s) described in this document in compliance with the requirements of the official Mexican standards (NOM)

Exporter: Dell Computer Corporation
One Dell Way
Round Rock, TX 78682

Importer: Dell Computer de México,
S.A. de C.V. Rio Lerma No. 302 - 4° Piso
Col. Cuauhtemoc 16500 México, D.F.

Ship to: Dell Computer de México,
S.A. de C.V. al Cuidado de Kuehne & Nagel
de México S. de R.L., Avenida Soles No. 55
Col. Peñon de los Baños, 15520 México, D.F.

Supply voltage: > 100/240 VAC

Frequency: 50/60 Hz

Current consumption: 1.0 A

Información para NOM (únicamente para México)

La información siguiente se proporciona en el dispositivo o en los dispositivos descritos en este documento, en cumplimiento con los requisitos de la Norma Oficial Mexicana (NOM):

Exporter: Dell Computer Corporation
One Dell Way
Round Rock, TX 78682

Importador: Dell Computer de México,
S.A. de C.V. Rio Lerma No. 302 - 4° Piso
Col. Cuauhtemoc 16500 México, D.F.

Dell Computer de México,

Embarcar a: S.A. de C.V. al Cuidado de Kuehne & Nagel
de México S. de R.L., Avenida Soles No. 55
Col. Peñon de los Baños, 15520 México, D.F.

Tensión alimentación: 100/240 VAC

Frecuencia: 50/60 Hz

Consumo de corriente: 1.0 A

BSMI Notice (Taiwan Only)

警告使用者 這是用於測試產品，在陸地的環境中使用時，可能會造成無線電干擾，在這種情況下，使用者應該要求採取某些適當的對策。

Dell Computer Corporation's Environmental Program

Please visit Dell's environmental Web site to learn more about Dell's environmental programs.

Regulatory Listing

Safety Certifications:

- UL 1950
- NOM
- CE Mark—EN60950: 1992 + A1 + A2 + A3
- NEMKO
- SEMKO
- EZU
- IEC 950
- TUV GS
- PCBC
- GOST
- CCC
- K-mark
- PSB

EMC Certifications:

- FCC Part 15 Class B
- CE Mark—EN55022:1998 Class B, EN61003-2:1995, EN61003-3:1995, EN55024:1998
- EZU
- NEMKO
- SEMKO
- PCBC
- GOST
- C-Tick
- VCCI Class B ITE
- MIC
- BSMI

Ergonomics:

- ENERGY STAR?
 - TCO 95
 - GOST Hygienic
-

Limited Warranties

Limited Warranties for Dell Branded Hardware Products • Limited Three-Year Warranty (U.S. Only) • Limited Three-Year Warranty (Canada Only) • One Year Dell Manufacturer End-User Guarantee European Union, Norway and Switzerland • "Total Satisfaction" Return Policy (U.S. and Canada Only)

Limited Warranties for Dell Branded Hardware Products

DELL-BRANDED HARDWARE PRODUCTS COME WITH A LIMITED WARRANTY. THE LIMITED WARRANTY COVERING YOUR PARTICULAR SYSTEM WILL BE NOTED ON YOUR INVOICE AND INCLUDED IN THE DOCUMENTATION ACCOMPANYING YOUR SYSTEM.

DELL-BRANDED MONITORS PURCHASED INDEPENDENT OF A SYSTEM PURCHASE COME WITH THE LIMITED WARRANTY SET OUT BELOW.

(For US customers, a copy of Dell's limited warranty statement can be obtained by writing Dell at USA L.P., Attn: Warranties, One Dell Way, Round Rock, TX 78682.)

Limited Three-Year Warranty (U.S. Only)

Dell Computer Corporation ("Dell") manufactures its hardware products from parts and components that are new or equivalent to new in accordance with industry-standard practices. Dell warrants that the hardware products it manufactures will be free from defects in materials and workmanship. The warranty term is three years beginning on the date of invoice, as described in the following text.

Damage due to shipping the products to you is covered under this warranty. Otherwise, this warranty does not cover damage due to external causes, including accident, abuse, misuse, problems with electrical power, servicing not authorized by Dell, usage not in accordance with product instructions, failure to perform required preventive maintenance, and problems caused by use of parts and components not supplied by Dell.

This warranty does not cover any items that are in one or more of the following categories: software; external devices (except as specifically noted); accessories or parts added to a Dell system after the system is shipped from Dell; accessories or parts added to a Dell system through Dell's system integration department; accessories or parts that are not installed in the Dell factory; or DellWareSM products. Displays, keyboards, and mice that are Dell-branded or that are included on Dell's standard price list are covered under this warranty; all other displays, keyboards, and mice (including those sold through the DellWare program) are not covered. Batteries for portable computers are covered only during the initial one-year period of this warranty.

Coverage During Year One

During the one-year period beginning on the invoice date, Dell will repair or replace products covered under this limited warranty that are returned to Dell's facility. To request warranty service, you must call Dell's Customer Technical Support within the warranty period. Refer to "Getting Help" in your *Installation and Troubleshooting Guide* to find the appropriate telephone number for obtaining customer assistance. If warranty service is required, Dell will issue a Return Material Authorization Number. You must ship the products back to Dell in their original or equivalent packaging, prepay shipping charges, and insure the shipment or accept the risk of loss or damage during shipment. Dell will ship the repaired or replacement products to you freight prepaid if you use an address in the continental U.S., where applicable. Shipments to other locations will be made freight collect.

 **NOTE:** Before you ship the product(s) to Dell, back up the data on the hard-disk drive(s) and any other storage device(s) in the product(s). Remove any removable media, such as diskettes, CDs, or PC Cards. Dell does not accept liability for lost data or software.

Dell owns all parts removed from repaired products. Dell uses new and reconditioned parts made by various manufacturers in performing warranty repairs and building replacement products. If Dell repairs or replaces a product, its warranty term is not extended.

Coverage During Years Two and Three

During the second and third years of this limited warranty, Dell will provide, on an exchange basis and subject to Dell's Exchange Policy in effect on the date of the exchange, replacement parts for the Dell hardware product(s) covered under this limited warranty when a part requires replacement. You must report each instance of hardware failure to Dell's Customer Technical Support in advance to obtain Dell's concurrence that a part should be replaced and to have Dell ship the replacement part. Dell will ship parts (freight prepaid) if you use an address in the continental U.S. or Canada, where applicable. Shipments to other locations will be made freight collect. Dell will include a prepaid shipping container with each replacement part for your use in returning the replaced part to Dell. Replacement parts are new or reconditioned. Dell may provide replacement parts made by various manufacturers when supplying parts to you. The warranty term for a replacement part is the remainder of the limited warranty term.

You will pay Dell for replacement parts if the replaced part is not returned to Dell. The process for returning replaced parts, and your obligation to pay for replacement parts if you do not return the replaced parts to Dell, will be in accordance with Dell's Exchange Policy in effect on the date of the exchange.

You accept full responsibility for your software and data. Dell is not required to advise or remind you of appropriate backup and other procedures.

General Provisions

THIS WARRANTY GIVES YOU SPECIFIC LEGAL RIGHTS WHICH VARY FROM STATE TO STATE (OR JURISDICTION TO JURISDICTION). DELL'S RESPONSIBILITY FOR MALFUNCTIONS AND DEFECTS IN HARDWARE IS LIMITED TO REPAIR AND REPLACEMENT AS SET FORTH IN THIS WARRANTY STATEMENT. ALL EXPRESS AND IMPLIED WARRANTIES FOR THE PRODUCT, INCLUDING BUT NOT LIMITED TO ANY IMPLIED WARRANTIES OF AND CONDITIONS OF MERCHANTABILITY AND FITNESS FOR A PARTICULAR PURPOSE, ARE LIMITED IN DURATION TO THE WARRANTY PERIOD SET FORTH ABOVE AND NO WARRANTIES, WHETHER EXPRESS OR IMPLIED, WILL APPLY AFTER SUCH PERIOD.

SOME STATES (OR JURISDICTIONS) DO NOT ALLOW LIMITATIONS ON HOW LONG AN IMPLIED WARRANTY LASTS, SO THE PRECEDING LIMITATION MAY NOT APPLY TO YOU.

DELL DOES NOT ACCEPT LIABILITY BEYOND THE REMEDIES SET FORTH IN THIS WARRANTY STATEMENT OR LIABILITY FOR INCIDENTAL OR CONSEQUENTIAL DAMAGES, INCLUDING WITHOUT LIMITATION ANY LIABILITY FOR PRODUCTS NOT BEING AVAILABLE FOR USE OR FOR LOST DATA OR SOFTWARE.

SOME STATES (OR JURISDICTIONS) DO NOT ALLOW THE EXCLUSION OR LIMITATION OF INCIDENTAL OR CONSEQUENTIAL DAMAGES, SO THE PRECEDING EXCLUSION OR LIMITATION MAY NOT APPLY TO YOU.

These provisions apply to Dell's limited three-year warranty only. For provisions of any service contract covering your system, refer to your invoice or the separate service contract that you will receive.

If Dell elects to exchange a system or component, the exchange will be made in accordance with Dell's Exchange Policy in effect on the date of the exchange. In any instance in which Dell issues a Return Material Authorization Number, Dell must receive the product(s) for repair prior to the expiration of the warranty period in order for the repair(s) to be covered by the warranty.

 *NOTE: If you chose one of the available warranty and service options in place of the standard limited three-year warranty described in the preceding text, the option you chose will be listed on your invoice.*

Limited Three-Year Warranty (Canada Only)

Dell Computer Corporation ("Dell") manufactures its hardware products from parts and components that are new or equivalent to new in accordance with industry-standard practices. Dell warrants that the hardware products it manufactures will be free from defects in materials and workmanship. The warranty term is three years beginning on the date of invoice, as described in the following text.

Damage due to shipping the products to you is covered under this warranty. Otherwise, this warranty does not cover damage due to external causes, including accident, abuse, misuse, problems with electrical power, servicing not authorized by Dell, usage not in accordance with product instructions, failure to perform required preventive maintenance, and problems caused by use of parts and components not supplied by Dell.

This warranty does not cover any items that are in one or more of the following categories: software; external devices (except as specifically noted); accessories or parts added to a Dell system after the system is shipped from Dell; accessories or parts added to a Dell system through Dell's system integration department; accessories or parts that are not installed in the Dell factory; or DellWareSM products. Displays, keyboards, and mice that are Dell-branded or that are included on Dell's standard price list are covered under this warranty; all other displays, keyboards, and mice (including those sold through the DellWare

program) are not covered. Batteries for portable computers are covered only during the initial one-year period of this warranty.

Coverage During Year One

During the one-year period beginning on the invoice date, Dell will repair or replace products covered under this limited warranty that are returned to Dell's facility. To request warranty service, you must call Dell's Customer Technical Support within the warranty period. Refer to "Getting Help" in your *Installation and Troubleshooting Guide* to find the appropriate telephone number for obtaining customer assistance. If warranty service is required, Dell will issue a Return Material Authorization Number. You must ship the products back to Dell in their original or equivalent packaging, prepay shipping charges, and insure the shipment or accept the risk of loss or damage during shipment. Dell will ship the repaired or replacement products to you freight prepaid if you use an address in Canada, where applicable. Shipments to other locations will be made freight collect.

 **NOTE:** Before you ship the product(s) to Dell, back up the data on the hard-disk drive(s) and any other storage device(s) in the product(s). Remove any removable media, such as diskettes, CDs, or PC Cards. Dell does not accept liability for lost data or software.

Dell owns all parts removed from repaired products. Dell uses new and reconditioned parts made by various manufacturers in performing warranty repairs and building replacement products. If Dell repairs or replaces a product, its warranty term is not extended.

Coverage During Years Two and Three

During the second and third years of this limited warranty, Dell will provide, on an exchange basis and subject to Dell Exchange Policy in effect on the date of the exchange, replacement parts for the Dell hardware product(s) covered under this limited warranty when a part requires replacement. You must report each instance of hardware failure to Dell's Customer Technical Support in advance to obtain Dell's concurrence that a part should be replaced and to have Dell ship the replacement part. Dell will ship parts (freight prepaid) if you use an address in the continental U.S. or Canada, where applicable. Shipments to other locations will be made freight collect. Dell will include a prepaid shipping container with each replacement part for your use in returning the replaced part to Dell. Replacement parts are new or reconditioned. Dell may provide replacement parts made by various manufacturers when supplying parts to you. The warranty term for a replacement part is the remainder of the limited warranty term.

You will pay Dell for replacement parts if the replaced part is not returned to Dell. The process for returning replaced parts, and your obligation to pay for replacement parts if you do not return the replaced parts to Dell, will be in accordance with Dell's Exchange Policy in effect on the date of the exchange.

You accept full responsibility for your software and data. Dell is not required to advise or remind you of appropriate backup and other procedures.

General Provisions

DELL MAKES NO EXPRESS WARRANTIES OR CONDITIONS BEYOND THOSE STATED IN THIS WARRANTY STATEMENT. DELL DISCLAIMS ALL OTHER WARRANTIES AND CONDITIONS, EXPRESS OR IMPLIED, INCLUDING WITHOUT LIMITATION IMPLIED WARRANTIES AND CONDITIONS OF MERCHANTABILITY AND FITNESS FOR A PARTICULAR PURPOSE. SOME STATES (OR JURISDICTIONS) DO NOT ALLOW LIMITATIONS ON IMPLIED WARRANTIES OR CONDITIONS, SO THIS LIMITATION MAY NOT APPLY TO YOU.

DELL'S RESPONSIBILITY FOR MALFUNCTIONS AND DEFECTS IN HARDWARE IS LIMITED TO REPAIR AND REPLACEMENT AS SET FORTH IN THIS WARRANTY STATEMENT. THESE WARRANTIES GIVE YOU SPECIFIC LEGAL RIGHTS, AND YOU MAY ALSO HAVE OTHER RIGHTS, WHICH VARY FROM STATE TO STATE (OR JURISDICTION TO JURISDICTION).

DELL DOES NOT ACCEPT LIABILITY BEYOND THE REMEDIES SET FORTH IN THIS WARRANTY STATEMENT OR LIABILITY FOR INCIDENTAL OR CONSEQUENTIAL DAMAGES, INCLUDING WITHOUT LIMITATION ANY LIABILITY FOR PRODUCTS NOT BEING AVAILABLE FOR USE OR FOR LOST DATA OR SOFTWARE.

SOME STATES (OR JURISDICTIONS) DO NOT ALLOW THE EXCLUSION OR LIMITATION OF INCIDENTAL OR CONSEQUENTIAL DAMAGES, SO THE PRECEDING EXCLUSION OR LIMITATION MAY NOT APPLY TO YOU.

These provisions apply to Dell's limited three-year warranty only. For provisions of any service contract covering your system, refer to your invoice or the separate service contract that you will receive.

If Dell elects to exchange a system or component, the exchange will be made in accordance with Dell's Exchange Policy in effect on the date of the exchange. In any instance in which Dell issues a Return Material Authorization Number, Dell must

receive the product(s) for repair prior to the expiration of the warranty period in order for the repair(s) to be covered by the warranty.



NOTE: If you chose one of the available warranty and service options in place of the standard limited three-year warranty described in the preceding text, the option you chose will be listed on your invoice.

One Year Dell Manufacturer End-User Guarantee European Union, Norway and Switzerland Guarantee

DELL Products, Raheen Industrial Estate, Limerick, Ireland (DELL) warrants to the end-user in accordance with the following provisions that its branded hardware products, purchased by the end-user from a DELL company or an authorized DELL distributor, in the European Union, Norway or Switzerland, will be free from defects in materials, workmanship and design affecting normal use, for a period of one year as of the original purchase date. Products for which proper claims are made will, at DELL's option, be repaired or replaced at DELL's expense.

Exclusions

This Guarantee does not apply to defects resulting from: improper or inadequate installation, use or maintenance; actions or modifications by unauthorized third parties or the end-user; accidental or wilful damage or normal wear and tear.

Making a claim

Claims must be made in the European Union, Norway or Switzerland, by contacting the point of sale or any DELL office within the guarantee period. The end-user must always supply proof of purchase, indicating name and address of the seller, date of purchase, model and serial number, name and address of the customer and details of symptoms and configuration at time of malfunction, including peripherals and software used. Otherwise, DELL may refuse the guarantee claim. Upon diagnosis of a warranted defect, DELL will make arrangements, and pay for ground freight and insurance to and from DELL repair/ replacement centre. End-user must ensure defective product is available for collection properly packed in original or equally protective packaging together with details listed above and the return number provided to the end-user by DELL.

Limitation and Statutory Rights

DELL makes no other warranty, guarantee or like statement other than as explicitly stated above and this Guarantee is given in place of all other guarantees whatsoever, to the fullest extent permitted by law. In the absence of applicable legislation, this Guarantee will be the end-user's sole and exclusive remedy against DELL or any of its affiliates, and neither DELL nor any of its affiliates shall be liable for loss of profit or contracts, or any other indirect or consequential loss arising from negligence, breach of contract, or howsoever.

This Guarantee does not impair or affect mandatory statutory rights of the end-user against and/or any rights resulting from other contracts concluded by the end-user with DELL and/or any other seller.

General Provisions

DELL MAKES NO EXPRESS WARRANTIES OR CONDITIONS BEYOND THOSE STATED IN THIS WARRANTY STATEMENT. DELL DISCLAIMS ALL OTHER WARRANTIES AND CONDITIONS, EXPRESS OR IMPLIED, INCLUDING WITHOUT LIMITATION IMPLIED WARRANTIES AND CONDITIONS OF MERCHANTABILITY AND FITNESS FOR A PARTICULAR PURPOSE. SOME STATES (OR JURISDICTIONS) DO NOT ALLOW LIMITATIONS ON IMPLIED WARRANTIES OR CONDITIONS, SO THIS LIMITATION MAY NOT APPLY TO YOU.

DELL'S RESPONSIBILITY FOR MALFUNCTIONS AND DEFECTS IN HARDWARE IS LIMITED TO REPAIR AND REPLACEMENT AS SET FORTH IN THIS WARRANTY STATEMENT. THESE WARRANTIES GIVE YOU SPECIFIC LEGAL RIGHTS, AND YOU MAY ALSO HAVE OTHER RIGHTS WHICH VARY FROM STATE TO STATE (OR JURISDICTION TO JURISDICTION).

DELL DOES NOT ACCEPT LIABILITY BEYOND THE REMEDIES SET FORTH IN THIS WARRANTY STATEMENT OR LIABILITY FOR INCIDENTAL OR CONSEQUENTIAL DAMAGES, INCLUDING WITHOUT LIMITATION ANY LIABILITY FOR PRODUCTS NOT BEING AVAILABLE FOR USE OR FOR LOST DATA OR SOFTWARE.

SOME STATES (OR JURISDICTIONS) DO NOT ALLOW THE EXCLUSION OR LIMITATION OF INCIDENTAL OR CONSEQUENTIAL DAMAGES, SO THE PRECEDING EXCLUSION OR LIMITATION MAY NOT APPLY TO YOU.

These provisions apply to Dell's limited three-year warranty only. For provisions of any service contract covering your system, refer to your invoice or the separate service contract that you will receive.



NOTE: If you chose one of the available warranty and service options in place of the standard limited three-year warranty described in the preceding text, the option you chose will be listed on your invoice.

"Total Satisfaction" Return Policy (U.S. and Canada Only)

If you are an end-user customer who bought new products directly from a Dell company, you may return them to Dell within 30 days of the date of invoice for a refund or credit of the product purchase price. If you are an end-user customer who bought reconditioned or refurbished products from a Dell company, you may return them to Dell within 14 days of the date of invoice for a refund or credit of the product purchase price. In either case, the refund or credit will not include any shipping and handling charges shown on your invoice. If you are an organization that bought the products under a written agreement with Dell, the agreement may contain different terms for the return of products than specified by this policy.

To return products, you must call Dell Customer Service to receive a Credit Return Authorization Number. Refer to "Getting Help" in your *Installation and Troubleshooting Guide* to find the appropriate telephone number for obtaining customer assistance. To expedite the processing of your refund or credit, Dell expects you to return the products to Dell in their original packaging within five days of the date that Dell issues the Credit Return Authorization Number. You must also prepay shipping charges and insure the shipment or accept the risk of loss or damage during shipment. You may return software for refund or credit only if the sealed package containing the diskette(s) or CD(s) is unopened. Returned products must be in as-new condition, and all of the manuals, diskette(s), CD(s), power cables, and other items included with a product must be returned with it. For customers who want to return, for refund or credit only, either applications software or an operating system that has been installed by Dell, the whole system must be returned, along with any media and documentation that may have been included in the original shipment.

This "Total Satisfaction" Return Policy does not apply to DellWare products, which may be returned under DellWare's then-current return policy. In addition, reconditioned parts purchased through Dell Spare Parts Sales in Canada are nonreturnable.

[Back to Contents Page](#)

Documentation: Dell™ 1800FP Color Display User's Guide

You must right-click the link for a portable document format (PDF) file and save the file to your hard-disk drive. Attempting to link directly to large PDF files can cause your system to freeze.

To save PDF files (files with an extension of **.pdf**) to your hard-disk drive, right-click the document title, click **Save Target As** in Microsoft® Internet Explorer or **Save Link As** in Netscape Navigator, and specify a location on your hard-disk drive.

Right-click only the following link:

"Quick Set-up" (.pdf)

*To view a PDF file, launch Adobe™ Acrobat Reader. Click **File** —> **Open** and select the PDF file.*



NOTE: *PDF files require Adobe Acrobat Reader, which can be downloaded from the [Adobe World Wide Web site](#).*
