

APPENDIX G :

USER'S MANUAL

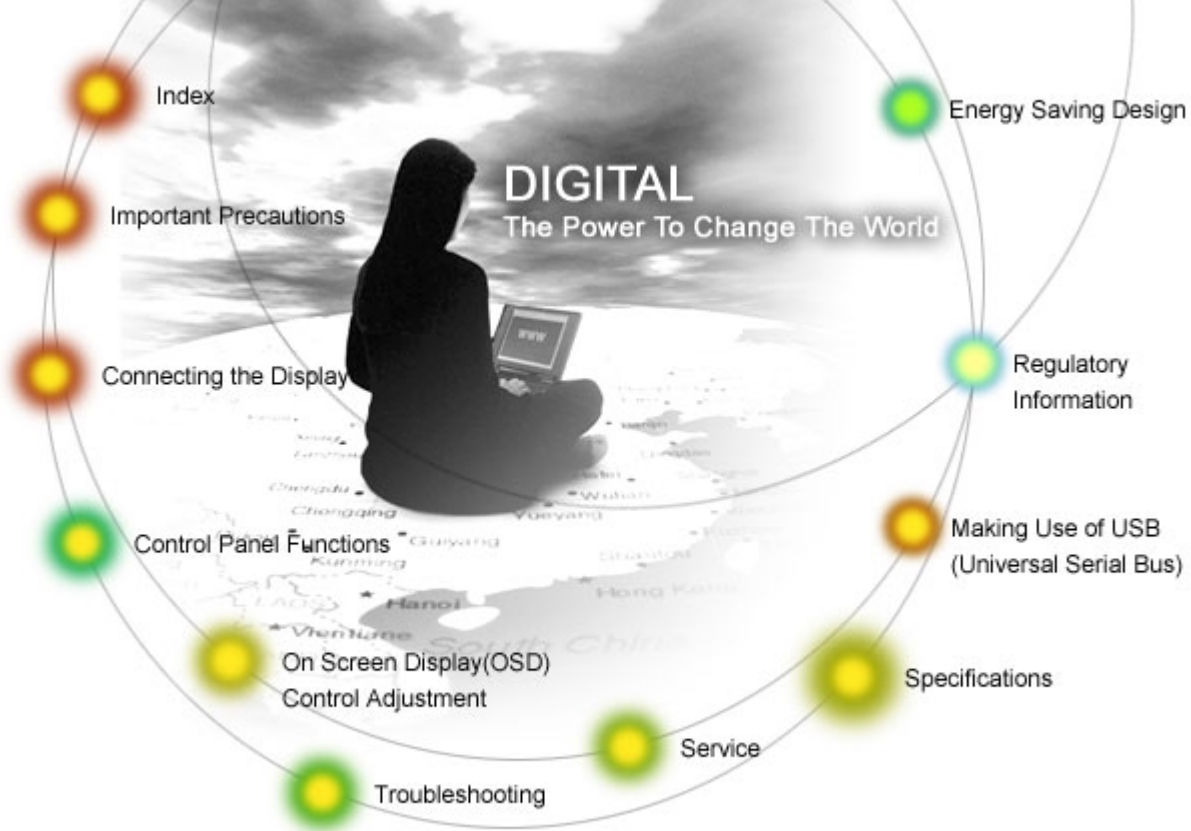

Important Precautions

This unit has been engineered and manufactured to ensure your personal safety, however improper use may result in potential e shock or fire hazards. In order to allow the proper operation of all safeguards incorporated in this display, observe the following basic rules for its installation, use, and servicing.

On Safety

Use only the power cord supplied with the unit. In case you use another power cord, make sure that it is certified by the applicable national standards if not being provided by the supplier. If the power cable is faulty in any way, please contact the manufacturer or the nearest authorized repair service provider for a replacement. The power supply cord is used as the main disconnection device. Ensure that the socket-outlet is easily accessible after installation.

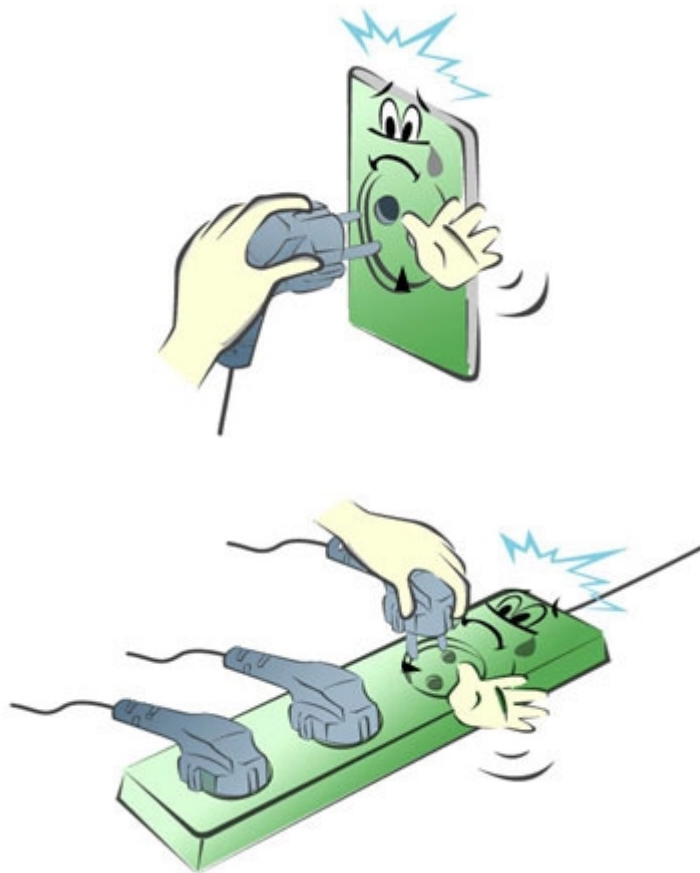

- Operate the display only from a power source indicated in the specifications of this manual or listed on the display. If you are not sure what type of power supply you have in your home, consult with your dealer.

- Overloaded AC outlets and extension cords are dangerous. So are frayed power cords and broken plugs. They may result in a shock or fire hazard. Call your service technician for replacement.

– Do not Open the Display.



- There are no user serviceable components inside.
- There are Dangerous High Voltages inside, even when the power is OFF.
- Contact your dealer if the display is not operating properly.

– To Avoid Personal Injury :



- Do not place the display on a sloping shelf unless properly secured.
- Use only a stand recommended by the manufacturer.

– To Prevent Fire or Hazards:



- Always turn the display OFF if you leave the room for more than a short period of time. Never leave the display ON when leaving the house.



- Keep children from dropping or pushing objects into the display's cabinet openings. Some internal parts carry hazardous voltages.

- Do not add accessories that have not been designed for this display.

- During a lightning storm or when the

display is to be left unattended for an extended period of time, unplug it from the wall outlet.

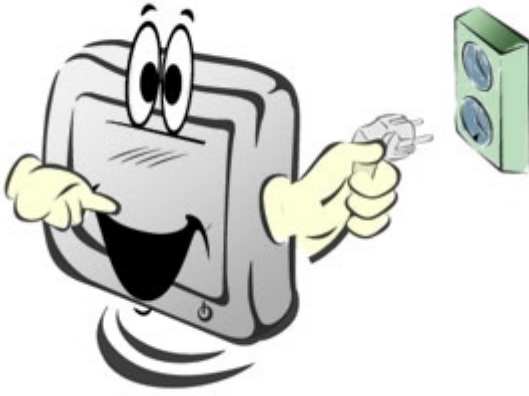

[TOP](#)

Important Precautions

This unit has been engineered and manufactured to ensure your personal safety, however improper use may result in potential e shock or fire hazards. In order to allow the proper operation of all safeguards incorporated in this display, observe the following basic rules for its installation, use, and servicing.

On Installation

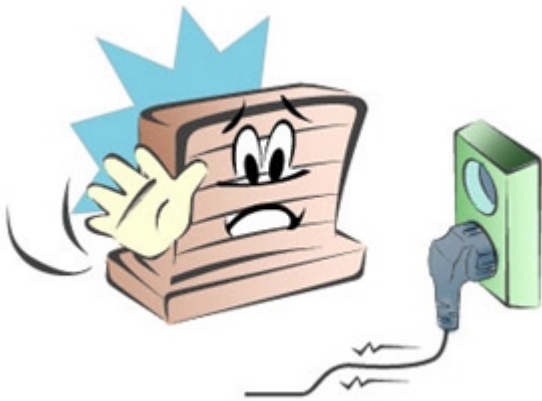

- Do not allow anything to rest upon or roll over the power cord, and do not place the display where the power cord is subject to damage.

- Do not use this display near water such as near a bathtub, washbowl, kitchen sink, laundry tub, in a wet basement, or near a swimming pool.

-Displays are provided with ventilation openings in the cabinet to allow the release of heat generated during operation. If these openings are blocked, built-up heat can cause failures which may result in a fire hazard. Therefore, NEVER:



- Block the bottom ventilation slots by placing the display on a bed, sofa, rug, etc.
- Cover the openings with cloth or other material.

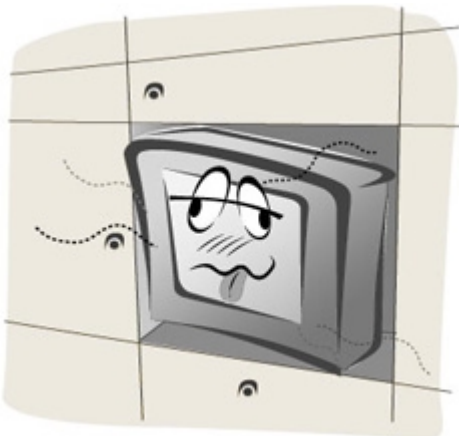

- Place the display in a built-in enclosure unless proper ventilation is provided.

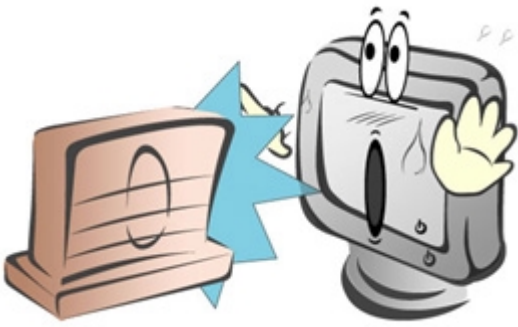

- Place the display near or over a radiator or heat source.

TOP

Do not rub or strike the Active Matrix LCD with anything hard as this may scratch, mar, or damage the Active Matrix LCD permanently.

Do not press the LCD screen with your finger for a long time as this may cause some afterimages.

Some dot defects may appear as Red, Green or Blue spots on the screen. However, this will have no impact or effect on the display performance.

If possible, use the recommended resolution to obtain the best image quality for your LCD display. If used under any mode except the recommended resolution, some scaled or processed images may appear on the screen. However, this is characteristic of the fixed-resolution LCD panel.

TOP

Important Precautions

This unit has been engineered and manufactured to ensure your personal safety, however improper use may result in potential e shock or fire hazards. In order to allow the proper operation of all safeguards incorporated in this display, observe the following basic rules for its installation, use, and servicing.

On Cleaning



- Unplug the display before cleaning the face of the display screen.

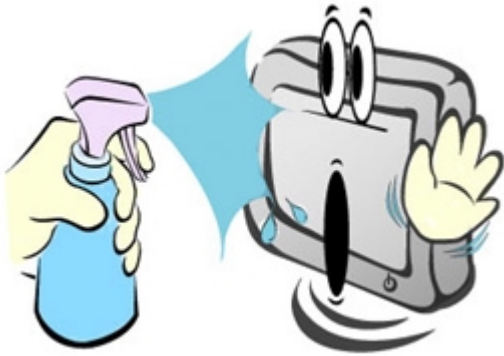

- Use a slightly damp (not wet) cloth. Do not use an aerosol directly on the display screen because over-spraying may cause electrical shock.

Important Precautions

This unit has been engineered and manufactured to ensure your personal safety, however improper use may result in potential e shock or fire hazards. In order to allow the proper operation of all safeguards incorporated in this display, observe the following basic rules for its installation, use, and servicing.

On Repacking



- Do not throw away the carton and packing materials. They make an ideal container in which to transport the unit. When shipping the unit to another location, repack it in its original material.

Important Precautions

Proper Posture

Proper posture to use the monitor

Adjust the angle of the monitor so that the screen slightly faces downward.

Long hours of use give eye strain. Make sure to take 10 minutes of break from the monitor every hour.

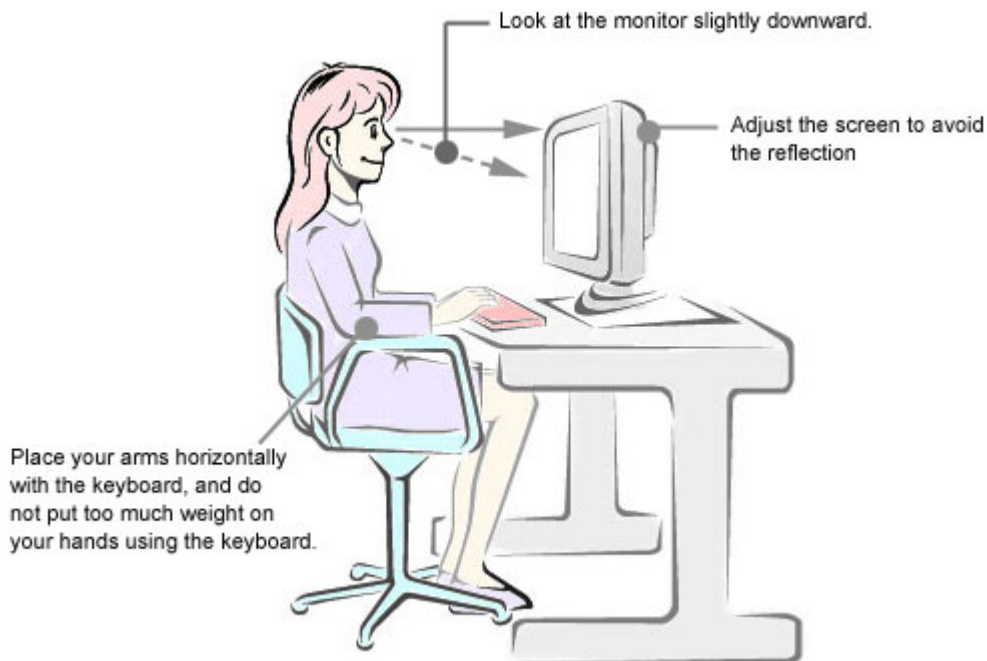

Connecting the Display

Using the Computer

1. Connect the signal cable. When attached, tighten the thumbscrews to secure the connection.
2. Connect the power cord into a proper power outlet that is easily accessible and close to the display.

NOTE

- This is a simplified representation of the rear view.
- This rear view represents a general model; your display may differ from the view as shown.

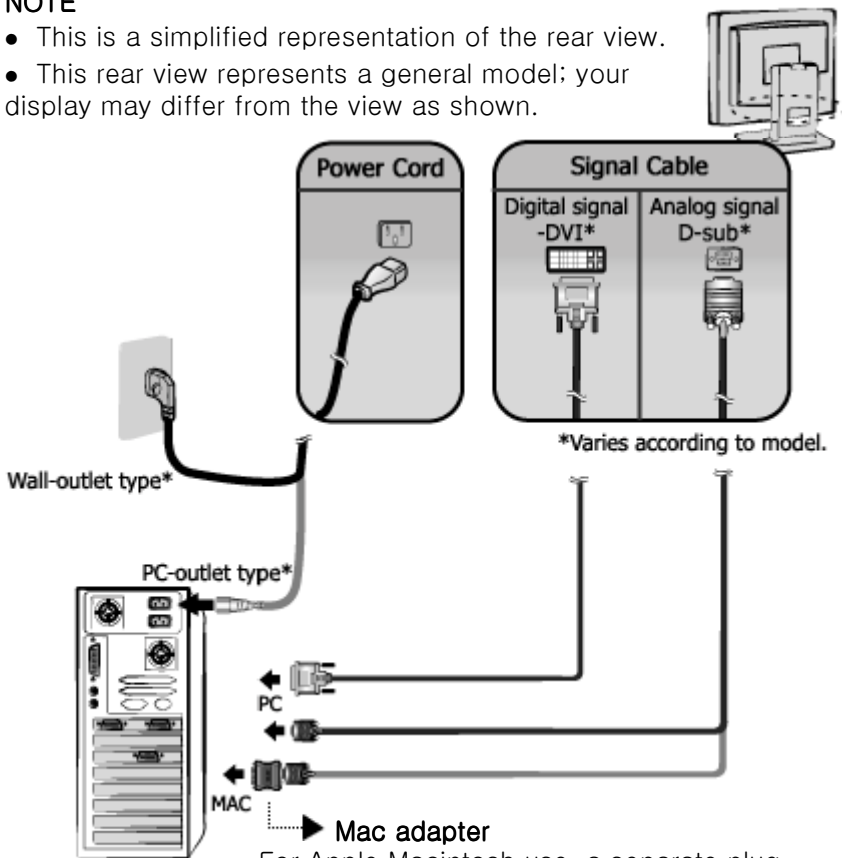

Mac adapter
For Apple Macintosh use, a separate plug adapter is needed to change the 15 pin high density (3 row) D-sub VGA connector on the supplied cable to a 15 pin 2 row connector.

Control Panel Functions

Front Panel Controls

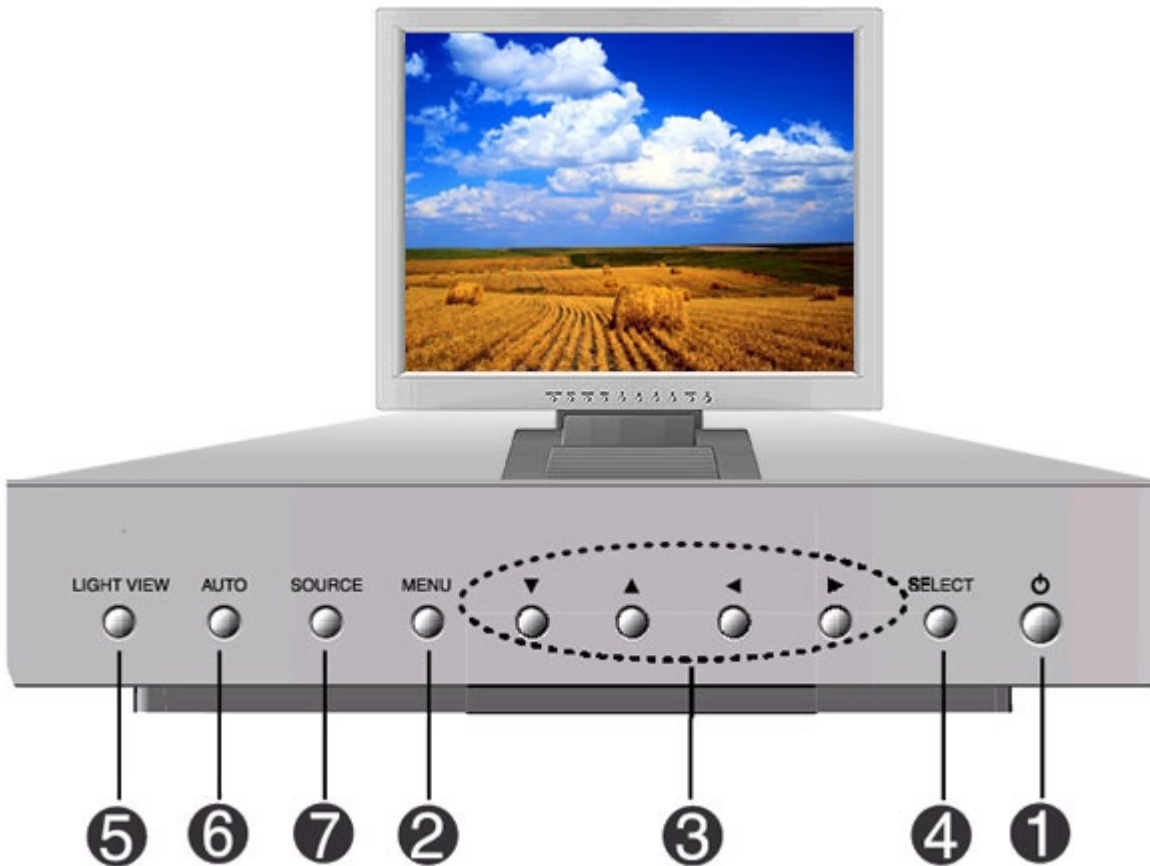

Control

Function

1

Power Button

Use this button to turn the display on or off.



Power (DPMS) Indicator

This Indicator lights up green when the display operates normally. If the display is in DPM (Energy Saving) mode, this indicator color changes to amber.

2

MENU



MENU Button

Use this button to enter or exit the On Screen Display.

3



Use these buttons to choose or adjust items in the On Screen Display.

4



SELECT Button

Use this button to enter a selection in the On Screen Display.

Direct Access Function

Direct Access Function

3

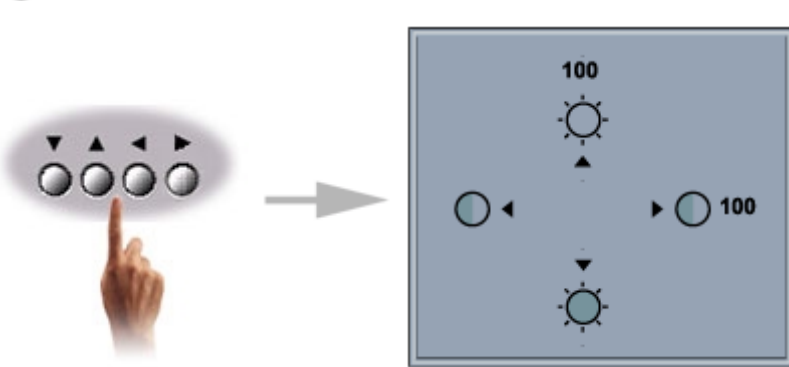

Bring up Contrast and Brightness adjustment.

5 LIGHT VIEW

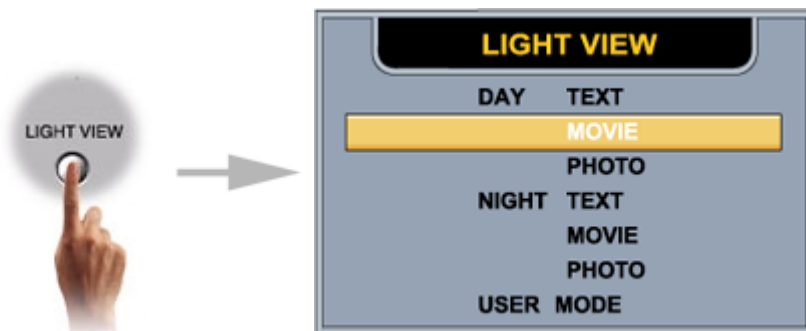

This function optimizes the brightness, contrast or color value to the surrounding conditions and settings and enables you to enjoy the most suitable picture by adjusting the surroundings (DAY/NIGHT/USER MODE).

- TEXT: For viewing letters
- MOVIE: For viewing movies
- PHOTO: For viewing pictures or the photographs
- USER MODE: This function memorizes the manual adjustment –Brightness, Contrast and Color value on the On Screen Display.

6 AUTO Adjustment Function

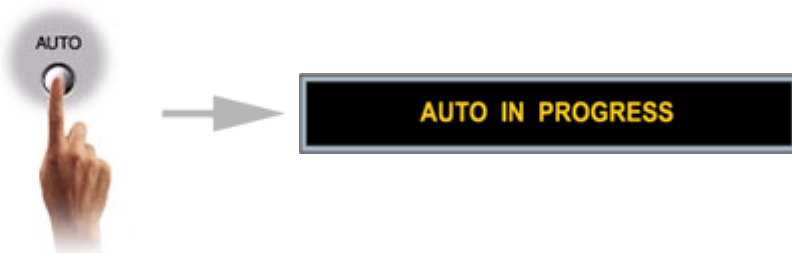

When adjusting your display settings, always press the AUTO/SELECT button before entering the On Screen Display (OSD). This will automatically adjust your display image to the ideal settings for the current screen resolution size (display mode).

The best display mode is **1600 X 1200@60Hz**.

7 SOURCE Selection: SOURCE → ▼ ▲ → SELECT

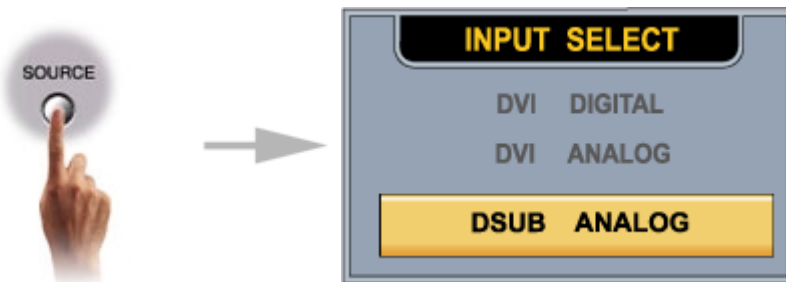

Use this button to make dvi digital, dvi analog or dsub analog connector active. This feature is used when two computers are connected to the display. The default setting is Dsub.

- DVI DIGITAL
- DVI ANALOG
- DSUB ANALOG

CONTROLS LOCKED/UNLOCKED: MENU and ►

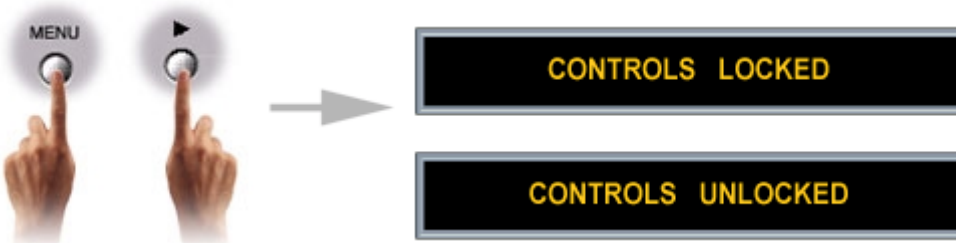

This function allows you to secure the current control settings, so that they cannot be inadvertently changed. Press and hold the MENU button and ► button for 3 seconds: the message "CONTROLS LOCKED" appears.

You can unlock the OSD controls at any time by pushing the MENU button and ► button for 3 seconds: "CONTROLS UNLOCKED" will appear.

On Screen Display(OSD) Control Adjustment

Screen Adjustment

Making adjustments to the image size, position and operating parameters of the display is quick and easy with the On Screen Display Control system. A short example is given below to familiarize you with the use of the controls. The following section is an outline of the available adjustments and selections you can make using the OSD.

NOTE

– Allow the display to stabilize for at least 30 minutes before making image adjustments.

To make adjustments in the On Screen Display, follow these steps:



1. Press the **MENU Button**, then the main menu of the OSD appears.
2. To access a control, use the **▼** or **▲ Buttons**. When the icon you want becomes highlighted, press the **SELECT Button**.
3. Use the **▼▲◀▶ Buttons** to adjust the item to the desired level.
4. Accept the changes by pressing the **SELECT Button**.
5. Exit the OSD by Pressing the **MENU Button**.

On Screen Display(OSD) Control Adjustment

On Screen Display(OSD) Selection and Adjustment

The following table indicates all the On Screen Display control, adjustment, and setting menus.

Main Menu	Sub Menu	A	D	Reference
BRIGHTNESS CONTRAST	BRIGHTNESS	●	●	To adjust the brightness and contrast of the screen
	CONTRAST	●		
COLOR	USER(R/G/B)	●		To customize the color of the screen
	9300K	●		
	6500K	●		
POSITION	H POSITION	●		To adjust the position of the screen
	V POSITION	●		
TRACKING	AUTO	●		To improve the clarity and stability of the screen
	CLOCK	●		
	PHASE	●		
SETUP	LANGUAGE	●	●	To customize the screen status for a user's operating environment
	IMAGE SIZE	●	●	
	TRANSPARENCY	●	●	
	ZOOM	●	●	
OSD POS	HORIZONTAL	●	●	To adjust position of the OSD window on the screen
	VERTICAL	●	●	

● : Adjustable A : Analog Input D : Digital Input

You were introduced to the procedure of selecting and adjusting an item using the OSD system.



Troubleshooting

Check the following before calling for service.

No Image Appears

No Image Appears	
Is the power cord of the display connected?	<ul style="list-style-type: none">• Check and see if the power cord is connected properly to the power outlet.
Is the power indicator light on?	<ul style="list-style-type: none">• Press the Power button.
Is the power on and the power indicator green?	<ul style="list-style-type: none">• Adjust the brightness and the contrast.
Is the power indicator amber?	<ul style="list-style-type: none">• If the display is in power saving mode, try moving the mouse or pressing any key on the keyboard to bring up the screen.• Make sure if the power is on. Turn the computer on if the power is off.
Do you see an "INPUT SIGNAL OUT OF RANGE" message on the screen?	<ul style="list-style-type: none">• This message appears when the signal from the PC (video card) is out of horizontal or vertical frequency range of the display. See the 'Specifications' section of this manual and configure your display again.
Do you see a "NO SIGNAL" message on the screen?	<ul style="list-style-type: none">• This message appears when the signal cable between your PC and your display is not connected. Check the signal cable and try again.



Troubleshooting

Check the following before calling for service.

Have You Installed the Display Driver?

Have You Installed the Display Driver?

Have you installed the display driver?

- Be sure to install the display driver from the display driver CD (or diskette) that comes with your display. Or, you can also download the driver from our web site: <http://www.lge.com>.

Troubleshooting

Check the following before calling for service.

Display Image is Incorrect

Display Image is Incorrect	
The screen is being distorted.	<ul style="list-style-type: none">• Check Control Panel -> Settings and see if the frequency or the resolution were changed. If yes, readjust the video card resolution to 1600 X 1200@60Hz.• Check if the video card or the driver were replaced. If yes, readjust the video card resolution to 1600 X 1200@60Hz and press AUTO button to run the Auto Screen Settings.
On the screen background, vertical bars or stripes are visible.	<ul style="list-style-type: none">• Press the AUTO button to automatically adjust your display image to the ideal setting. If the results are unsatisfactory, decrease the vertical bars or stripes using the CLOCK icon in the on screen display.
Any horizontal noise appearing in any image or characters are not clearly portrayed.	<ul style="list-style-type: none">• Press the AUTO button to automatically adjust your display image to the ideal setting. If the results are unsatisfactory, decrease the horizontal bars using the PHASE icon in the on screen display.• Check Control Panel -> Settings and adjust the resolution to 1600 X 1200@60Hz and adjust your display image to the ideal setting. Set the color setting higher than 24 bits (true color).
The screen color is mono or abnormal.	<ul style="list-style-type: none">• Check if the signal cable is properly connected and use a screwdriver to fasten.• Make sure the video card is properly inserted in the slot.• Set the color setting higher than 24 bits (true color) at Control Panel - Settings.
The screen blinks.	<ul style="list-style-type: none">• Check if the screen is set to interlace mode and if yes, change it to 1600 X 1200@60Hz mode.• Interlace Mode : Vertical frequency 87Hz(I)• Make sure the power voltage is high enough. It has to be higher than AC 100 -240V 50/60Hz.



Service

Unplug the monitor from the wall outlet and refer servicing to qualified service personnel when :

- The power cord or plug is damaged or frayed.
- Liquid has been spilled into the monitor.
- The monitor has been exposed to rain or water.
- The monitor does not operate normally following the operating instructions. Adjust only those controls that are covered in the operating instructions. An improper adjustment of other controls may result in damage and often requires extensive work by a qualified technician to restore the monitor to normal operation.
- The monitor has been dropped or the cabinet has been damaged.
- The monitor exhibits a distinct change in performance.
- Snapping or popping from the monitor is continuous or frequent while the monitor is operating. It is normal for some monitors to make occasional sounds when being turned on or off, or when changing video modes.

Do not attempt to service the monitor yourself, as opening or removing covers may expose you to dangerous voltage or other hazards. Refer all servicing to qualified service personnel.

Specifications

Specifications

Display	20.1 inches (51.0cm) Flat Panel Active matrix-TFT LCD Anti-Glare coating 20.1 inches viewable 0.255mm pixel pitch				
Sync Input	Horizontal Freq.	Analog : 30 – 98kHz (Automatic) Digital : 30–83kHz (Automatic)			
	Vertical Freq.	56 – 85Hz (Automatic)			
	Input Form	Separate TTL, Positive/Negative Composite TTL Positive/Negative SOG (Sync On Green) Digital			
Video Input	Signal Input	15 pin D-Sub Connector DVI – I connector (Digital/Analog)			
	Input Form	RGB Analog (0.7Vp-p/75ohm), Digital			
Resolution	Max	Digital:VESA 1600 x 1200@60Hz Analog:VESA 1600 x 1200@75Hz			
	Recommend	VESA 1600 x 1200@60Hz			
Plug&Play	DDC 2B				
Power Consumption	Status		Power consumption	LED color	
	Normal		60 W(65W)	Green	
	DPM	Stand-by/suspend		≤5 W(10W)	Amber
		DPM Off		≤3 W(10W)	
	Power key off		≤3 W(10W)	Off	
	Power cut-off switch off		≤1 W(1W)		
* () : with USB					
Display Color	16.7 M Color (True)				
Signal Cable	15pin-to-15pin D-sub Cable, DVI-D Cable (Detachable)				
Maximum Pixel Clock	205 MHz				
Dimensions&Weight (with tilt/swivel stand)	Width	44.6 cm / 17.56 inches			
	Height	44.67 cm / 17.59 inches			
	Depth	22.23 cm / 8.75 inches			
	Net	9.168 kg (20.19 lbs)			
Tilt/Swivel Range	Tilt	-5° ~ 30°			
	Swivel	360°			
Power Input	AC 100–240V 50/60Hz 1.0A				
EnvironmentalConditions	Operating Conditions Temperature 10℃ to 35℃ Humidity 10% to 80% non-Condensing				
	Storage Conditions Temperature -20℃ to 60℃ Humidity 5% to 95% non-Condensing				
Tilt/Swivel Stand	Attached(O), Detached ()				

Power Cord	Wall-outlet type or PC-outlet type
Regulations	TCO99

NOTE

- Information in this document is subject to change without notice.

TOP



Specifications

Preset Modes(Resolution)

	Display Modes (Resolution)	Horizontal Freq. (kHz)	Vertical Freq. (Hz)
1	640 x 350	31.47	70
2	640 x 480	31.47	60
3	640 x 480	37.50	75
4	640 x 480	43.27	85
5	720 x 400	31.47	70
6	800 x 600	37.88	60
7	800 x 600	46.88	75
8	800 x 600	53.67	85
9	832 x 624	49.72	75
10	1024 x 768	48.36	60
11	1024 x 768	60.02	75
12	1024 x 768	68.68	85
13	1152 x 870	68.68	75
14	1152 x 900	61.80	65.96
15	1280 x 1024	63.98	60.02
16	1280 x 1024	79.98	75.02
17	1600 x 1024	62.11	60
18	1600 x 1200	75.00	60
19	1600 x 1200	93.75	75

Specifications

VESA Wall Mounting & Kensington Security Slot

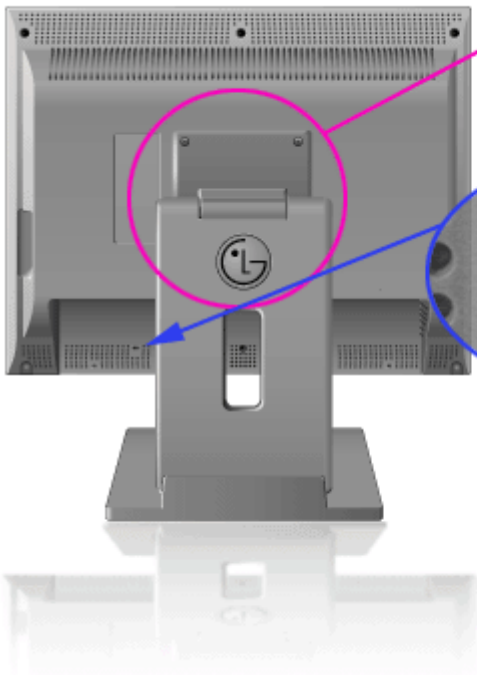

VESA Wall Mounting

Connected to another object(stand type and wall-mounted type. This monitor accepts a VESA-compliant mounting interface pad.)

Kensington Security Slot-optional

Connected to another object(stand type and wall-mounted type. This monitor accepts a VESA-compliant mounting interface pad.)

Specifications

Signal Connector Pin Assignment

- [DVI-I CONNECTOR](#)
- [15 PIN D-SUB CONNECTOR](#)

> DVI-I CONNECTOR

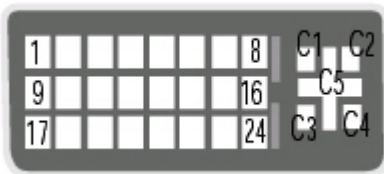

Pin	Signal(DVI-I)
1	T. M. D. S. Data2-
2	T. M. D. S. Data2+
3	T. M. D. S. Data2/4 Shield
4	T. M. D. S. Data4-
5	T. M. D. S. Data4+
6	DDC Clock
7	DDC Data
8	Analog Vertical Sync.
9	T. M. D. S. Data1-
10	T. M. D. S. Data1+
11	T. M. D. S. Data1/3 Shield
12	T. M. D. S. Data3-
13	T. M. D. S. Data3+
14	+5V Power
15	Ground (return for +5V, H. Sync. and V. Sync.)
16	Hot Plug Detect
17	T. M. D. S. Data0-
18	T. M. D. S. Data0+
19	T. M. D. S. Data0/5 Shield
20	T. M. D. S. Data5-
21	T. M. D. S. Data5+
22	T. M. D. S. Clock Shield
23	T. M. D. S. Clock+
24	T. M. D. S. Clock-
C1	Analog Red
C2	Analog Green
C3	Analog Blue
C4	Analog H. Sync.
C5	Analog Ground

T.M.D.S. (Transition Minimized Differential Signaling)

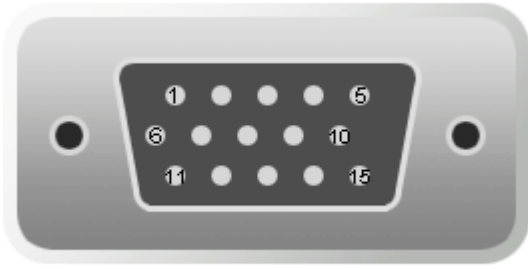
> 15 PIN D-SUB CONNECTOR

Pin	Signal(15 pin S-Sub)
1	Red
2	Green
3	Blue
4	Ground
5	Self-Test
6	Red Ground
7	Green Ground
8	Blue Ground
9	NC
10	Ground
11	Ground
12	SDA
13	Hori.Sync
14	Vert.Sync
15	SCL

Making Use of USB (Universal Serial Bus)

USB (Universal Serial Bus) is an innovation in connecting your different desktop peripherals conveniently to your computer. By using the USB, you will be able to connect your mouse, keyboard, and other peripherals to your display instead of having to connee maintaining the Plug and the Plug auto detection and configuration. This display has an integrated self-powered USB hub, allowing up to 2 other USB devices to be attached it.

USB Connection

1. Connect the upstream port of the display to the downstream port of the USB compliant PC or another hub using the USB cable. (Computer must have a USB port)
2. Connect the USB compliant peripherals to the downstream ports of the display.
This is a simplified representation of rear view.
To USB downstream port of the USB compliant PC or another hub cable
USB downstream Port
connect the cables from USB compliant peripherals—such as keyboard, mouse, etc

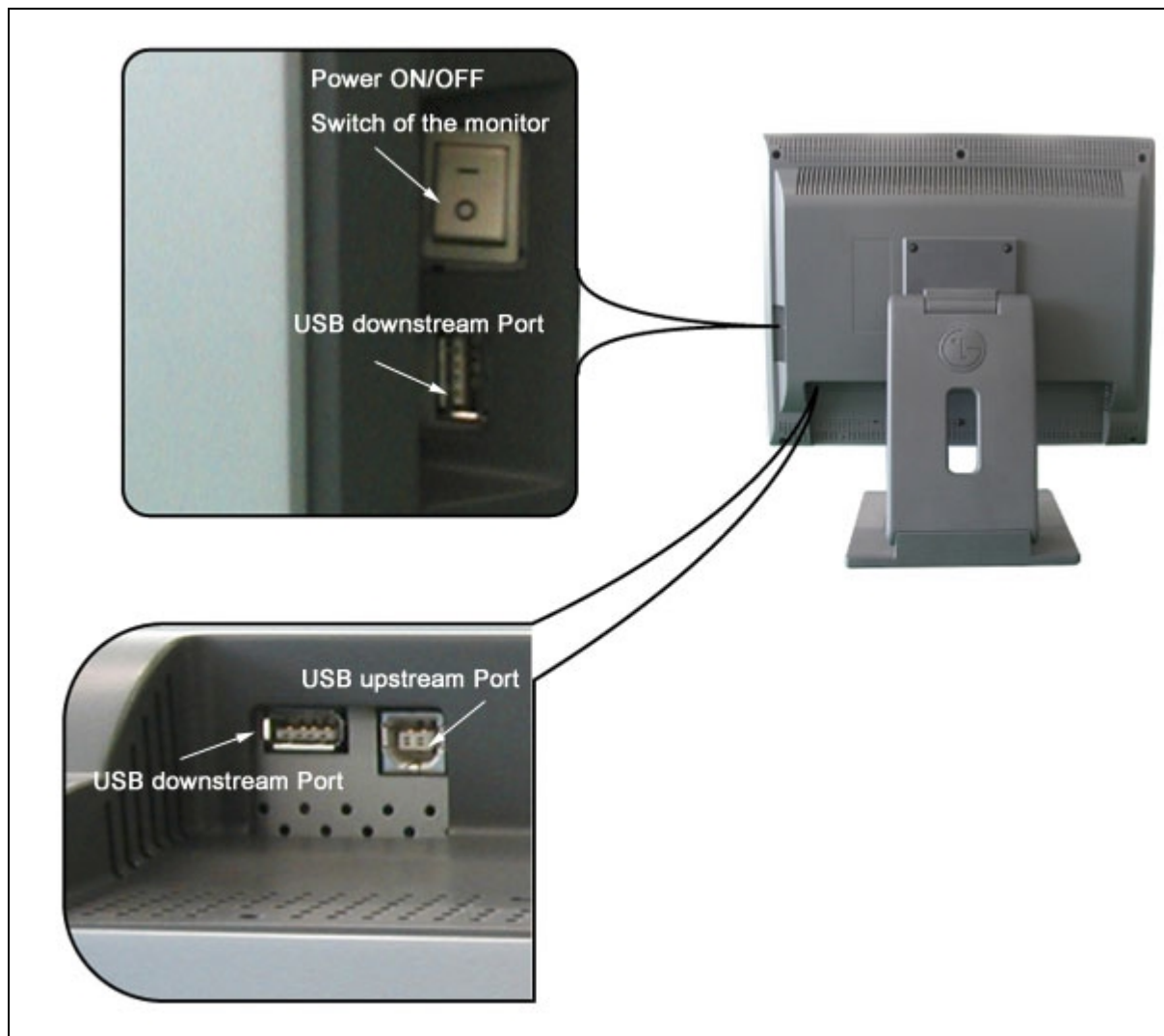

NOTE

- To activate the USB hub function, the display must be connected to a USB compliant PC(OS) or another hub with the USB cable(enclosed).
- When connecting the USB cable, check that the shape of the connector at the cable side matches the

shape at the connecting side.

- Even if the display is in a power saving mode, USB compliant devices will function when they are connected the USB ports(both the upstream and downstream) of the display.

[TOP](#)



Making Use of USB (Universal Serial Bus)

USB (Universal Serial Bus) is an innovation in connecting your different desktop peripherals conveniently to your computer. By using the USB, you will be able to connect your mouse, keyboard, and other peripherals to your display instead of having to connec maintaining the Plug and the Plug auto detection and configuration. This display has an integrated self-powered USB hub, allowing up to 2 other USB devices to be attached it.

USB Specifications

USB Standard	Rev. 1.1 complied self-powered hub
Downstream Power Supply	500mA for each (MAX)
Communication Speed	12 Mbps (full), 1.5 Mbps (low)
USB Port	1 Upstream port / 2 Downstream ports



Regulatory Information

- ▶ FCC Compliance Statement
- ▶ Canadian DOC Notice
- ▶ CE Conformity Notice (for Europe)
- ▶ Low Radiation Compliance (MPR II)
- ▶ TCO95
- ▶ TCO99
- ▶ EPA (U.S.A only)
- ▶ NOM MARK (Mexico only)
- ▶ 情報処理装置等電波障害自主規制について

FCC Compliance Statement

This equipment has been tested and found to comply within the limits of a Class B digital device pursuant to Part 15 of the FCC Rules. These limits are designed to provide reasonable protection against harmful interference in a residential installation.

This equipment generates, uses, and can radiate radio frequency energy and if not installed and used in accordance with the instructions, may cause harmful interference to radio communications. However, there is no guarantee that interference will not occur in a particular installation.

If this equipment does cause harmful interference to radio or television reception (which can be determined by turning the equipment on and off), the user is encouraged to try to correct the interference by using one or more of the following measures:

- Reorient or relocate the receiving antenna.
- Increase the separation between the equipment and the receiver.
- Connect the equipment into an outlet on a circuit different from that to which the receiver is connected.
- Consult the dealer or an experienced radio/TV technician for help.

Caution: Changes or modifications not expressly approved by the party responsible for compliance could void the user's (or your) authority to operate the equipment. Only peripherals (digital input/output devices, terminals, printers, etc.) certified to comply with the Class B limits may be attached to this monitor. Operation with non-certified peripherals is likely to result in interference to radio and TV reception. Only shielded signal cables may be used with this System.

NOTICE

– The regulations are applied only to the products with the ID LABEL indicating specific requirements.



Regulatory Information

- ▶ FCC Compliance Statement
- ▶ Canadian DOC Notice
- ▶ CE Conformity Notice (for Europe)
- ▶ Low Radiation Compliance (MPR II)
- ▶ TCO95
- ▶ TCO99
- ▶ EPA (U.S.A only)
- ▶ NOM MARK (Mexico only)
- ▶ 情報処理装置等電波障害自主規制について

Canadian DOC Notice

This Class B digital apparatus meets all requirements of the Canadian Interference-Causing Equipment Regulations.

Cet appareil numérique de la classe B respecte toutes les exigences du Règlement sur le matériel brouilleur du Canada.

NOTICE

– The regulations are applied only to the products with the ID LABEL indicating specific requirements.



Regulatory Information

- ▶ FCC Compliance Statement
- ▶ Canadian DOC Notice
- ▶ CE Conformity Notice (for Europe)
- ▶ Low Radiation Compliance (MPR II)
- ▶ TCO95
- ▶ TCO99
- ▶ EPA (U.S.A only)
- ▶ NOM MARK (Mexico only)
- ▶ 情報処理装置等電波障害自主規制について

CE Conformity Notice (for Europe)

Products with the “CE” Marking comply with the EMC Directive(89/336/EEC) and LOW VOLTAGE Directive (73/23/EEC) issued by the Commission of the European Community.

Compliance with these directives implies conformity to the following European Norms :

- EN 55022 ; Radio Frequency Interference
- EN 50082-1:1992 ; Electromagnetic Immunity
- EN 60555-2 ; Power Line Harmonics
- EN 60555-3 ; Voltage Fluctuations
- EN 60950 ; Product Safety

NOTICE

- The regulations are applied only to the products with the ID LABEL indicating specific requirements.



Regulatory Information

- ▶ FCC Compliance Statement
- ▶ Canadian DOC Notice
- ▶ CE Conformity Notice (for Europe)
- ▶ Low Radiation Compliance (MPR II)
- ▶ TCO95
- ▶ TCO99
- ▶ EPA (U.S.A only)
- ▶ NOM MARK (Mexico only)
- ▶ 情報処理装置等電波障害自主規制について

Low Radiation Compliance (MPR II)

This monitor meets one of the strictest guidelines available today for low radiation emissions, offering the user extra shielding and an antistatic screen coating. These guidelines, set forth by a government agency in Sweden, limit the amount of emission allowed in the Extremely Low Frequency (ELF) and Very Low Frequency (VLF) electromagnetic range.



Regulatory Information

- ▶ FCC Compliance Statement
- ▶ Canadian DOC Notice
- ▶ CE Conformity Notice (for Europe)
- ▶ Low Radiation Compliance (MPR II)
- ▶ TCO95
- ▶ TCO99
- ▶ EPA (U.S.A only)
- ▶ NOM MARK (Mexico only)
- ▶ 情報処理装置等電波障害自主規制について

TCO95



Congratulations!

You have just purchased a TCO'95 approved and labelled product! Your choice has provided you with a product developed for professional use. Your purchase has also contributed to reducing the burden on the environment and to the further development of environmentally-adapted electronic products.

Why do we have environmentally labelled computers?

In many countries, environmental labelling has become an established method for encouraging the adaptation of goods and services to the environment. The main problem as far as computers and other electronic equipment are concerned is that environmentally harmful substances are used both in the products and during their manufacture.

Since it has not been possible so far for the majority of electronic equipment to be recycled in a satisfactory way, most of these potentially damaging substances sooner or later enter Nature.

There are also other characteristics of a computer, such as energy consumption levels, that are important from both the working and natural environment viewpoints. Since all types of conventional electricity generation have a negative effect on the environment (acidic- and climatic-influencing emissions, radioactive waste, etc.), it is vital to conserve energy. Electronic equipment in offices consumes an enormous amount of energy, since it is often routinely left running continuously.

What does the environmental labelling involve?

This product meets the requirements for the TCO'95 scheme, which provides for international environmental labelling of personal computers. The labelling scheme was developed as a joint effort by the TCO (The Swedish Confederation of Professional Employees),

Naturkyddsforeningen (The Swedish Society for Nature Conservation), and NUTEK (The National Board for Industrial and Technical Development in Sweden), and SEMKO AB (an international certification agency).

The requirements cover a wide range of issues:

environment, ergonomics, usability, emission of electrical and magnetic fields, energy consumption and electrical and fire safety.

The environmental demands concern, among other things, restriction on the presence and use of heavy metals, brominated and chlorinated flame retardants, CFCs (freons), and chlorinated solvents. The product must be prepared for recycling, and the manufacturer is obliged to have an environmental plan, which must be adhered to in each country where the company implements its operational policy.

The energy requirements include a demand that the computer and/or display, after a certain period of inactivity, shall reduce its power consumption to a lower level, in one or more stages. The length of time to reactivate the computer shall be reasonable for the user.

Labelled products must meet strict environmental demands, for example, in respect of the reduction of electric and magnetic fields, along with physical and visual ergonomics and good usability.

The following is a brief summary of the environmental requirements met by this product. The complete environmental criteria document may be ordered from:

TCO Development Unit
Linnegatan 14, S-11494 Stockholm, Sweden
FAX +46-8 782 92 07
E-mail (Internet): development@tco.se

Current information regarding TCO'95 approved and labelled products may also be obtained on the Internet using the address: <http://www.tco-info.com/>

TCO'95 is a co-operative project between:



Naturkydds
föreningen

NUTEK

SEMKO

Närings- och teknikutvecklingsverket

Environmental requirements

Brominated flame retardants are present in printed circuit boards, cabling, casings, and housings, and are added to delay the spread of fire. Up to 30% of the plastic in a computer casing can consist of flame-retardant substances. These are related to another group of environmental toxins, PCBs, and are suspected of giving rise to similar harm, including reproductive damage in fish-eating birds and mammals. Flame retardants have been found in human blood, and researchers fear that they can disturb fetus development. Bio-accumulative¹ TCO'95 demands require that plastic components weighing more than 25 grams must not contain flame retardants with organically bound chlorine or bromine.

Lead can be found in picture tubes, display screens, solder, and capacitors. Lead damages the nervous system and in higher doses causes lead poisoning. The relevant bioaccumulative TCO'95 requirement permits the inclusion of lead, as no replacement has yet been developed.

Cadmium is present in rechargeable batteries and in the color-generating layers of certain computer displays. Cadmium damages the nervous system and is toxic in high doses. The relevant bio-accumulative TCO'95 requirement states that batteries may not contain more than 25 ppm (parts per million) of cadmium. The color-generating layers of display screens must not contain any cadmium.

Mercury is sometimes found in batteries, relays and switches. Mercury damages the nervous system and is toxic in high doses. The relevant bio-accumulative TCO'95 requirement states that batteries may not contain more than 25 ppm of mercury and that no mercury is present in any of the electrical or electronic components concerned with the display unit.

CFCs (freons) are sometimes used for washing printed circuit boards and in the manufacture of expanded foam for packaging. CFCs break down ozone and thereby damage the ozone layer in the atmosphere, causing increased reception on Earth of ultra-violet light with consequent increased risks of skin cancer (malignant melanoma). The relevant TCO'95 requirement: Neither CFCs nor HCFCs may be used during the manufacture of the product or its packaging.

¹ Bio-accumulative means that the substance accumulates within living organisms.

Shipping Package

The packaging material can be recycled, or you can save it to return the monitor to a service center for repair or disposal.

CFC Compounds in Distribution Packaging

Cushioning material used for shipping finished monitors are not manufactured with nor do they contain any CFC compounds.

Design for Disassembly/Recycling

These monitors have been designed for easy end-of-life disassembly and recycling. Fasteners are generally of the same type for efficient disassembly. Components made of different materials can be easily separated and plastics have been identified using international symbols to aid in recycling.

Monitor Disposal

WARNING

– If you need to dispose of a monitor, ask a qualified service representative for the proper procedure. Improper disposal could result in personal injury from implosion.

TOP



Regulatory Information

- ▶ FCC Compliance Statement
- ▶ Canadian DOC Notice
- ▶ CE Conformity Notice (for Europe)
- ▶ Low Radiation Compliance (MPR II)
- ▶ TCO95
- ▶ TCO99
- ▶ EPA (U.S.A only)
- ▶ NOM MARK (Mexico only)
- ▶ 情報処理装置等電波障害自主規制について

TCO99



Congratulations!

You have just purchased a TCO'99 approved and labelled product! Your choice has provided you with a product developed for professional use. Your purchase has also contributed to reducing the burden on the environment and also to the further development of environmentally adapted electronics products.

Why do we have environmentally labelled computers?

In many countries, environmental labelling has become an established method for encouraging the adaptation of goods and services to the environment. The main problem, as far as computers and other electronics equipment are concerned, is that environmentally harmful substances are used both in the products and during their manufacture. Since it is not so far possible to satisfactorily recycle the majority of electronics equipment, most of these potentially damaging substances sooner or later enter nature.

There are also other characteristics of a computer, such as energy consumption levels, that are important from the viewpoints of both the work (internal) and natural (external) environments. Since all methods of electricity generation have a negative effect on the environment (e.g. acidic and climateinfluencing emissions, radioactive waste), it is vital to save energy. Electronics equipment in offices is often left running continuously and thereby consumes a lot of energy.

What does labelling involve?

This product meets the requirements for the TCO'99 scheme which provides for international and environmental labelling of personal computers. The labelling scheme was developed as a joint effort by the TCO (The Swedish Confederation of Professional Employees), Svenska Naturskyddsforeningen (The Swedish Society for Nature Conservation) and Statens Energimyndighet (The Swedish National Energy Administration).

Approval requirements cover a wide range of issues:

environment, ergonomics, usability, emission of electric and magnetic fields, energy consumption and electrical and fire safety.

The environmental demands impose restrictions on the presence and use of heavy metals, brominated and chlorinated flame retardants, CFCs (freons) and chlorinated solvents, among other things. The product must be prepared for recycling and the manufacturer is obliged to have an environmental policy which must be adhered to in each country where the company implements its operational policy.

The energy requirements include a demand that the computer and/or display, after a certain period of inactivity, shall reduce its power consumption to a lower level in one or more stages. The length of time to reactivate the computer shall be reasonable for the user.

Labelled products must meet strict environmental demands, for example, in respect of the reduction of electric and magnetic fields, physical and visual ergonomics and good usability.

Below you will find a brief summary of the environmental requirements met by this product. The complete environmental criteria document may be ordered from:

TCO Development

SE-114 94 Stockholm, Sweden

Fax: +46 8 782 92 07

Email (Internet): development@tco.se

Current information regarding TCO'99 approved and labelled products may also be obtained via the Internet, using the address: <http://www.tco-info.com/>

Environmental requirements

Flame retardants

Flame retardants are present in printed circuit boards, cables, wires, casings and housings. Their purpose is to prevent, or at least to delay the spread of fire. Up to 30% of the plastic in a computer casing can consist of flame retardant substances. Most flame retardants contain bromine or chloride, and those flame retardants are chemically related to another group of environmental toxins, PCBs. Both the flame retardants containing bromine or chloride and the PCBs are suspected of giving rise to severe health effects, including reproductive damage in fish-eating birds and mammals, due to the bioaccumulative* processes. Flame retardants have been found in human blood and researchers fear that disturbances in foetus development may occur.

The relevant TCO'99 demand requires that plastic components weighing more than 25 grams must not contain flame retardants with organically bound bromine or chlorine. Flame retardants are allowed in the printed circuit boards since no substitutes are available.

Cadmium**

Cadmium is present in rechargeable batteries and in the colour-generating layers of certain computer displays. Cadmium damages the nervous system and is toxic in high doses. The relevant TCO'99 requirement states that batteries, the colour-generating layers of display screens and the electrical or electronics components must not contain any cadmium.

Mercury**

Mercury is sometimes found in batteries, relays and switches. It damages the nervous system and is toxic in high doses. The relevant TCO'99 requirement states that batteries may not contain any mercury. It also demands that mercury is not present in any of the electrical or electronics components associated with the labelled unit.

CFCs (freons)

The relevant TCO'99 requirement states that neither CFCs nor HCFCs may be used during the manufacture and assembly of the product. CFCs (freons) are sometimes used for washing printed circuit boards. CFCs break down ozone and thereby damage the ozone layer in the stratosphere, causing increased reception on earth of ultraviolet light with e.g. increased risks of skin cancer (malignant melanoma) as a consequence.

Lead**

Lead can be found in picture tubes, display screens, solders and capacitors. Lead damages the nervous system and in higher doses, causes lead poisoning.

The relevant TCO'99 requirement permits the inclusion of lead since no replacement has yet been developed.

* Bio-accumulative is defined as substances which accumulate within living organisms

** Lead, Cadmium and Mercury are heavy metals which are Bio-accumulative.



Regulatory Information

- ▶ FCC Compliance Statement
- ▶ Canadian DOC Notice
- ▶ CE Conformity Notice (for Europe)
- ▶ Low Radiation Compliance (MPR II)
- ▶ TCO95
- ▶ TCO99
- ▶ EPA (U.S.A only)
- ▶ NOM MARK (Mexico only)
- ▶ 情報処理装置等電波障害自主規制について

EPA (U.S.A only)

ENERGYSTAR is a set of power-saving guidelines issued by the U.S. Environmental Protection Agency(EPA).



As an ENERGY STAR Partner LGE U.S.A.,Inc. has determined that this product meets the ENERGY STAR guidelines for energy efficiency.



Regulatory Information

- ▶ FCC Compliance Statement
- ▶ Canadian DOC Notice
- ▶ CE Conformity Notice (for Europe)
- ▶ Low Radiation Compliance (MPR II)
- ▶ TCO95
- ▶ TCO99
- ▶ EPA (U.S.A only)
- ▶ NOM MARK (Mexico only)
- ▶ 情報処理装置等電波障害自主規制について

NOM MARK (Mexico only)

NOM

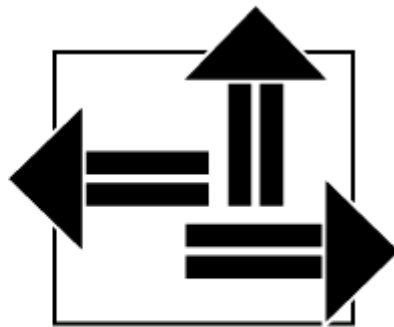

NYCE



Regulatory Information

- ▶ FCC Compliance Statement
- ▶ Canadian DOC Notice
- ▶ CE Conformity Notice (for Europe)
- ▶ Low Radiation Compliance (MPR II)
- ▶ TCO95
- ▶ TCO99
- ▶ EPA (U.S.A only)
- ▶ NOM MARK (Mexico only)
- ▶ 情報処理装置等電波障害自主規制について

情報処理装置等電波障害自主規制について

この装置は、第二種情報装置（住宅地域又はその隣接した地域において使用されるべき情報装置）で住宅地域での電波障害防止を目的とした情報処理装置等電波障害自主規制協議会（VCCI）基準に適合しております。

しかし、本装置をラジオ、テレビジョン受信機に接近してご使用になると、受信障害の原因となることがあります。

取扱説明書に従って正しい取り扱いをしてください。

警告 本製品のマニュアルに記載のない方法で調整などの作業を実施することは危険ですので、絶対に避けてください。

注! チルト・スィーベルスタンドの取り付け、取り外しの場合には接続されている機器の電源をオフにし、接続されているケーブルをすべて外してから行ってください。



This monitor complies with the EPA's Energy Star program, which is a program designed to have manufacturers of computer equipment build circuitry into their products to reduce power consumption during time of non-use.

When this monitor is used with a Green or EPA Energy Star PC, or a PC with a screen blanking software following the VESA Display Power Management Signalling (DPMS) protocol, this monitor can conserve significant energy by reducing power consumption during periods of non-use.

There are 2 signal lines, 4 modes of operation.
; Normal, Standby, Suspend and Off.

Mode	Horizontal Sync.	Vertical Sync.	LED Color
Normal	On	On	Green
Standby	Off	On	Amber
Suspend	On	Off	Amber
Off	Off	Off	Amber

When you awaken your PC by hitting a key or moving the mouse, the monitor will also awaken to its normal operating mode, indicated by the green Power LED light.

NOTE

– The energy saving Design for monitors only work when connected to computers that have energy saving features.