

# LG-530G User Guide



- Some of the contents of this manual may not apply to your phone depending on your phone's software or your service provider.
- Copyright ©2012 LG Electronics, Inc. All rights reserved. LG and the LG logo are registered trademarks of LG Group and its related entities. All other trademarks are the property of their respective owners.

# Your Phone

## Phone Components

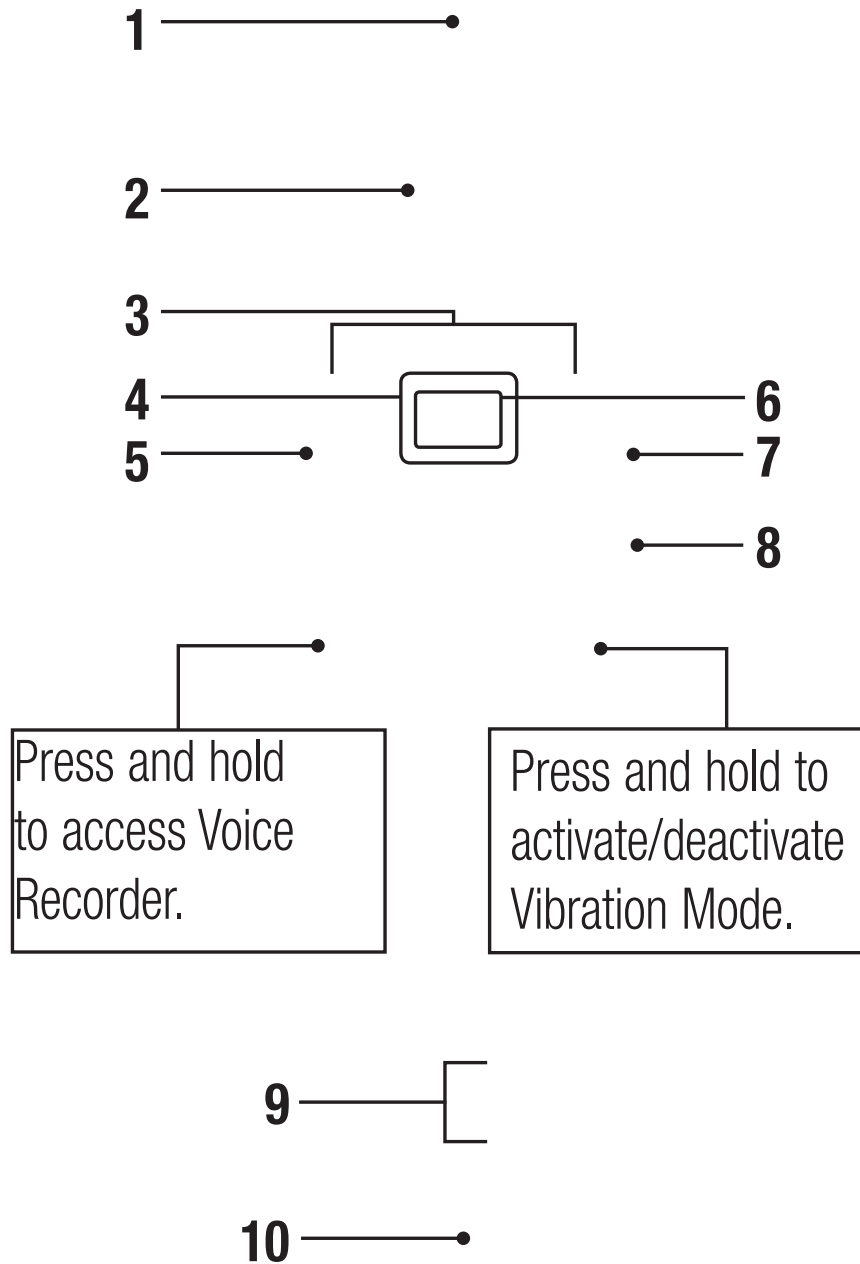

# Your Phone

- 1. Earpiece:** Lets you hear the caller during a call.
- 2. Main LCD:** Displays phone status icons, menu items, web items, web information, pictures and more, in full color.
- 3. Left soft key/Right soft key:** Each of these keys perform the functions indicated by the text on the display immediately above them.

## 4. Navigation keys

Standby Mode Hotkeys:

 Contact List

 New Message

 Calendar

 My Stuff

- In a menu: Navigates between menus.

- 5. Send key:** Press this key in standby mode to quickly access the most recent missed, dialed, and received calls.

## 6. OK key

- 7. End/Power key:** Allows you to power the phone on or off, end calls, or return to standby mode.

- 8. Clear key:** Allows you to return to the previous screen. Press and hold to activate the Voice Command function.

- 9. Volume keys:** Allows you to control the Master Volume while in standby mode and the earpiece volume during a call.

## 10. Charger/USB port

# Rear view

**EXTERNAL  
CAMERA LENS**



**SD CARD SLOT**



**SIM CARD SLOT**



**BATTERY COVER**



**BATTERY**



# Getting Started

## Installing the SIM card and battery

### 1. Remove the battery cover

Use your right thumb to press on the bottom center of the battery cover, then slide the cover upwards (as depicted below). Then, lift the cover to remove it.

### 2. Remove the battery

Hold the top edge of the phone and use the fingernail cutouts near the bottom of the battery to lift the battery from the phone.

### Warning

Do not remove the battery when the phone is turned on; this can damage the phone.

### 3. Install the SIM card

Slide the SIM card into the SIM card slot (as shown below). Make sure that the gold contact area on the card is facing downwards. To remove the SIM card, pull it gently in the opposite direction.

#### **4. Install the battery**

Insert the top of the battery first into the top edge of the battery compartment. Ensure that the battery contacts align with the terminals on the phone. Press the bottom of the battery down until it snaps into place.

## **Charging your phone**

Unfasten the cover of the Charger/USB port on the left side of your phone. Insert the charger connector to the phone (the 'LG' side of the connector has to be facing up when connecting to the phone) and then plug into the wall socket. Your LG-530G will need to be charged until the Full Battery message appears on the screen.

### **Important!**

You must insert the battery before charging.

# Getting Started

## Warning

Use of unauthorized accessories could damage your phone and void your warranty.

## Installing a memory card

You can expand the memory available on your phone by using a microSD™ memory card.

## Tip

A memory card is an optional accessory.

**1** Locate the microSD card slot on the right side of the phone. Then, use your fingernail to gently lift the cover.

The cover will remain attached to the phone, so that it does not become lost.

**2** With the microSD card facing up, slide it into the microSD card slot (as demonstrated in the following image).

Push the memory card in until it locks into place.











**3** Replace the slot cover on the phone.













## Note

If your memory card has existing content, it will automatically be filed in the correct folder. For example, videos will be accessible from the Videos folder.

## On-Screen Icons

The table below describes various display indicators or icons that appear on the phone's display screen.





ICON/ INDICATOR	DESCRIPTION
	Multitasking
	Network signal strength (number of bars will vary)
	No network signal
	Low Battery
	New text message
	New email
	An alarm is set
	Ring profile in use
	Silent All profile in use
	EDGE network available
	Bluetooth is active

ICON/ INDICATOR	DESCRIPTION
	3G network available
	The browser is active
	Vibrating Mode On
	Speakerphone
	Call in Progress
	Voicemail
	Battery Full
	Battery Charging
	Flight Mode On
	camera in use
	camcorder is recording
	camcorder timer



# General Functions

## Making a Call



- 1 Make sure your phone is powered on.
- 2 Enter a phone number including the area code. To edit a number on the display screen, simply press the  key to erase one digit at a time.
  - ▶ Press and hold the  key to erase the entire number.
- 3 Press the  [SEND] key to call the number.
- 4 To end the call, press the  [END] key.

## Making a Call with the Send Key

- 1 Press the  [SEND] key, and the most recent missed, dialed and received calls will be displayed.
- 2 Highlight the desired number by using the navigation keys.

- 3 Press the  [SEND] key.

## Making International Calls

- 1 Press and hold the  key and the international access character '+' will appear.
- 2 Enter the country code, area code, and the phone number.
- 3 Press the  [SEND] key to call the number.

## Ending a Call

To end a call, press the  [END] key.

## Making a Call from the Contacts



You can store frequently called names and phone numbers in the SIM card as well as in the phone memory known as the Contacts. You can dial a number by simply highlighting a name in the Contacts





List and pressing the  [SEND] key.

- 1 Press the  [Down] key to access the Contact List.
- 2 Highlight the Contact and press the  [SEND] key.

## Answering a Call

When you receive a call, the phone displays a notification on the screen and rings and/or vibrates. If the caller can be identified, the caller's phone number (or name, if stored in your Address Book) is displayed.

- 1 Press the  [SEND] key or the left soft key . Accept to answer an incoming call.

If the Answer Mode has been set as **Any Key** ( **Menu** >  **Settings** >  **Call** >  **Answer Mode**), any key press will answer a call, except for the  [END] key, the

right soft key , or the volume keys .

- 2 End the call by pressing the  [END] key.

### Note

You can answer a call while using other functions or features.

# General Functions

## Adjusting the Volume

Use the side volume keys during a call to adjust the earpiece volume.

While in standby mode, you can adjust the Master Volume using the side volume keys.

## Vibrating Mode (Quick)

Vibrating Mode can be activated by pressing and holding down the



key.

## Signal Strength

If you are inside a building, being near a window may give you better reception. You can see the strength of your signal by the signal indicator on your phone's display screen.

## Entering Text

You can enter alphanumeric characters by using the phone's keypad. For example, storing names in the Address Book, writing a message, or scheduling events in the calendar all require text to be entered.

## Changing the Text Input Mode

Change the text input mode by holding down  when in a text entry field.

You can check the current text input mode in the upper right corner of the screen.

The following text input modes are available on the phone.

### ABC Mode



This mode allows you to enter letters by pressing the key labeled with the required letter one, two,

three, or four times until the letter is displayed.

## 123 Mode (Numbers Mode)



Type numbers using one keystroke per number. To change to 123 mode in a text entry field, press the  key until 123 mode is displayed in the upper right corner.

## Symbol Mode

The Symbol Mode enables you to enter various symbols or special characters. To enter a symbol, press the  key. Use the navigation keys to highlight the desired symbol and press the  key.

## Using the ABC Mode

Use the alphanumeric keypad to enter your text.

- 1 Press the key labeled with the required letter:
  - ▶ Once for the first letter.
  - ▶ Twice for the second letter.
  - ▶ And so on.
- 2 To insert a space, press the  key once. To delete letters, press the  key. Press and hold down the  key to erase all of the entered text.

# General Functions

## Note

Refer to the table below for more information on the characters available using the keys.

Key	Characters in the Order Displayed	
	Upper Case	Lower Case
1	., '@?! -:/1	., '@?!-:/1
2	A B C 2	a b c 2
3	D E F 3	d e f 3
4	G H I 4	g h i 4
5	J K L 5	j k l 5
6	M N O 6	m n o 6
7	P Q R S 7	p q r s 7
8	T U V 8	t u v 8
9	W X Y Z 9	w x y z 9
0	Space Key, 0 (Long press)	Space Key, 0 (Long press)

## Using the 123 (Numbers) Mode

The 123 Mode enables you to enter numbers in a text message (a telephone number, for example) more quickly. Press the keys corresponding to the required digits before manually switching back to the appropriate text entry mode.



# In-Call Menu

## During a Call

Your phone provides a number of control functions that you can use during a call. To access these functions during a call, press the left soft key  **Options**.



## Making a Second Call

You can select a number you wish to dial from the Address Book to make a second call.

- 1 Press the left soft key  Options, then select **Address Book**.
- 2 Highlight the contact, then press the  [SEND] key to make a second call.

## Swapping Between Two Calls

Once the second call has been dialed (or answered), you can switch between the calls by using one of the following three methods:

- ▶ Press the  [SEND] key.
- ▶ Press the left soft key  Options and then select “Swap Calls”.
- ▶ Press Up/Down on the navigation key.

## Answering an Incoming Call

To answer an incoming call when the handset is ringing, simply press the  [SEND] key. The handset is also able to warn you of an incoming call while you are already on a call. A tone sounds in the earpiece and the display will show that a second call is waiting. This feature, known as **Call Waiting**, is only available if your network supports it.



If Call Waiting is turned on, you can put the first call on hold and answer the second call by pressing the  [SEND] key.

# In-Call Menu

## Rejecting an Incoming Call

You can reject an incoming call without answering by simply pressing the  [END] key.

## Muting the Microphone

You can mute the microphone during a call by pressing the right soft key  **Mute**. The handset can be unmuted by pressing the right soft key 

**Unmute**. When the handset is muted, the caller cannot hear you, but you can still hear the caller.

## Using the Speakerphone

You can use the integrated Speakerphone during a call by pressing the  key. The loudspeaker is automatically deactivated when you end the call.

### Warning

Due to increased volume levels, do not place the phone near your ear while the speakerphone is enabled.



## Conference Calls

The conference call feature provides you with the ability to have a simultaneous conversation with more than one caller. The conference call feature can be used only if your network service provider supports this feature.

Once a conference call is set up, calls may be added, disconnected (**Exclude Call** option allows you to select a call to disconnect from the conference call), or separated (**Private Call** option allows you to separate a call from the conference call, but still connected to you) by the person who set up the conference call. These options are all available from the In-Call menu.

The maximum number of callers in a conference call is five. Once started, you are in control of the conference call, and only you can add calls to the conference call.

## Making a Second Call

You can make a second call while currently on a call simply by entering the second number with the keypad and pressing the  [SEND] key. When the second call is connected, the first call is automatically placed on hold. You can swap between calls by pressing the  [SEND] key.



# In-Call Menu

## Setting Up a Conference Call

To set up a conference call, place the first call. Once that is connected, follow the steps above to make a second call. You can then join the two separate calls by pressing the left soft key  Options, selecting **Conference Call**, and then **Join Calls**.

## Place the Conference Call on Hold

To place a conference call on hold, press the  [SEND] key.

## Adding Calls to the Conference Call

To add a call to an existing conference call, press the left soft key  Options, select **Conference Call**, and then select **Join Calls**.

## Private Call in a Conference Call

To have a private call with one of the callers in the conference call, press the left soft key  Options, select **Conference Call**, and then **Private Call**. When the numbers of the callers are displayed, select the one with which you wish to speak in private.

## Ending a Conference Call

An active conference call can be disconnected by pressing the  [END] key.

# Menu Tree

## 1. Prepaid

- 1.1 Add Airtime
- 1.2 Buy Airtime
- 1.3 My Phone Number
- 1.4 My Airtime Info
- 1.5 Airtime Display
- 1.6 Serial Number
- 1.7 SIM Number
- 1.8 Code Entry Mode

## 2. Contacts

- 2.1 Contact List
- 2.2 New Contact
- 2.3 Groups
- 2.4 Speed Dial
- 2.5 SIM Management
- 2.6 Own Number
- 2.6 My Business Card

## 3. Messages

- 3.1 Create Message
- 3.2 Inbox
- 3.3 Drafts

## 3.4 Outbox

## 3.5 Message Settings

## 4. Recent Calls

- 4.1 All Calls
- 4.2 Missed Calls
- 4.3 Dialed Calls
- 4.4 Received Calls

## 5. Games & Apps

## 6. E-mail

## 7. Music

- 7.1 Now Playing
- 7.2 All Songs
- 7.3 Playlists
- 7.4 Artists
- 7.5 Albums
- 7.6 Genres
- 7.7 Shuffle Songs

# Menu Tree

## 8. Camera

8.1 Take Photo

8.2 Record Video

8.3 Camera Album

## 9. My Folder

9.1 Audio

9.2 Pictures

9.3 Video

9.4 Other Files

9.5 File Manager

## 10. Tools

10.1 Alarm Clock

10.2 Calendar

10.3 Notepad

10.4 Calculator

10.5 Tasks

10.6 Stopwatch

10.7 Tip Calculator

10.8 Unit Converter

10.9 Voice Recorder

## 11. Browser

## 12. Settings

### 12.1 Audio & Ringtones

12.1.1 Ringtone

12.1.2 Message Tone

12.1.3 Alert Tone

12.1.4 Keypad Tones

12.1.5 Multimedia

12.1.6 Call

### 12.2 Phone Settings

12.2.1 Languages

12.2.2 Set Hotkeys

12.2.3 Auto Key Lock

12.2.4 Flight Mode

12.2.5 Security

12.2.6 Reset Settings

### 12.3 Display

12.3.1 Wallpapers

12.3.2 Fonts

12.3.3 Clocks & Calender

12.3.4 Brightness

12.3.5 Backlight Timer

12.3.6 Color Schemes

12.3.7 Menu Styles

## **12.4 Call**

12.4.1 Send My Number

12.4.2 Answer Mode

12.4.3 Time & Cost

12.4.4 Accessibility

## **12.5 Bluetooth**

12.5.1 Turn On(Turn off)

12.5.2 Search New Device

12.5.3 My Devices

12.5.4 My Bluetooth Info

## **12.6 Memory**

12.6.1 Used Space

12.6.2 Set Storage Defaults

## **12.7 Application**

12.7.1 Messages

12.7.2 Browser

## **12.8 Phone Information**

# Prepaid

This manu allows you to check the prepaid related contents.

To access Prepaid, from the standby screen, press the left soft key

 **Menu** and  **Prepaid**.

You can access the Menu below.

- 1** Add Airtime – Recharge the fee using the Airtime PIN code.
- 2** Buy Airtime – Recharge the fee by selecting from the calling plan.
- 3** My Phone Number – Shows your phone number.
- 4** Airtime Info – Shows you the Airtime info. Based on different brand such as Balance, Due Date, and Service End Date etc.
- 5** Airtime Display – Set On/Off for displaying Balance / Due Date on Idle screen.
- 6** Serial Number – Shows you the Serial Number.
- 7** SIM Number – Shows you the SIM Number.
- 8** Code Entry Mode – Allows you to insert the device code for Tracfone's PPE setting or info.

# Contacts

## Contact List

This menu allows you to save and manage contact address information. The Contact List's functions allow you to add a new address or search saved contact addresses by name.

To access Contact List, from the standby screen, press the left soft key  **Menu**,  **Contacts** and  **Contact List**.



## New Contact

This menu allows you to add a new contact to the Contact List. You can enter contact address information including name, phone numbers, email addresses, group information items, memos, ring tones, and a contact Picture ID.

To access New Contact, from the standby screen, press the left soft key  **Menu**,  **Contacts** and  **New Contact**.

## Caller Groups

This menu allows you to manage group information. You can also configure a ring tone for a group so that the group ring tone sounds when a call from a specific contact address within that group is received and there is no ring tone configured for the specific contact address.

To access Caller Groups, from the standby screen, press the left soft key  **Menu**,  **Contacts** and  **Caller Groups**.

## Speed Dial



This menu allows you to assign a frequently-called contact to the Speed Dial List. You can select a number from 2 to 9 as a speed dial.

To access Speed Dial List, from the standby screen, press the left soft key  **Menu**,  **Contacts** and  **Speed Dial**.

# Contacts



## SIM Management

This menu allows you to copy information from your SIM card to your handset and vice versa. If a name is duplicated during the copying operation, the information is also duplicated. You can also delete information from the SIM card.

To access SIM Management, from the standby screen, press the left soft key  **Menu**,  **Contacts** and  **SIM Management**.



## Own number

This displays your phone numbers stored in the SIM card.

To access Own number, from the standby screen, press the left soft key  **Menu**,  **Contacts** and  **Own Number**.

## My business card



This display your business card stored in the handset. You can also delete or edit.

To access My business card, from the standby screen, press the left soft key  **Menu**,  **Contacts** and  **My business card**.

# Messages

This menu includes functions related to SMS (Short Message Service), MMS (Multimedia Message Service), Voicemail as well as the network's service messages.

## Create Message

- 1 From the standby screen, press the left soft key  **Menu**.
- 2 Press  **Messages**.
- 3 Press  **Create Message**.

### OR

You can simply press  [Up] from the standby screen.

### Note



If you insert a Picture, Audio, or Video file while writing a multimedia message, the file loading time will take about 5 seconds. You will not be able to activate any key during the file loading time. When the file loading is complete, you will be able to write a multimedia message.

## Editing a message

The following options are available when editing a message.













### Using Insert

While entering text, press the left soft key  **Options**. In this menu, you can choose Insert.

- **Symbol:** You can insert various symbols into your message. Pressing the Up and Down keys  /  scrolls through the pages.



# Messages

- ▶ **Picture:** You can select a picture to insert by using the navigation keys. You can preview the selected picture by pressing the left soft key  **View**.
- ▶ **Audio:** You can insert an audio file from your saved audio files.
- ▶ **Video:** You can insert a video clip from your saved video clips.
- ▶ **Take New Picture:** you can take and insert a picture in your message.
- ▶ **Record New Audio:** You can record a new audio clip by pressing  **Record**. Press the right soft key  **Options** before you begin recording to set the options (below). After recording a new audio clip, you can delete it by pressing the right key  **Delete**.
- **Quality:** Set the audio's quality to Fine, Normal, or Economy.
- **Select Storage Defaults:** You can assign the default storage to **Phone Memory** or **Memory Card**.
- ▶ **Record New Video:** You can record a new video by pressing  **Record**. When finished recording, press  **Insert**.
- ▶ **Template**
  - **Text:** Allows you to easily insert frequently used sentences in the text message.
  - **Multimedia:** Preset multimedia templates can be created (  **Menu** >  **Messages** > |  **Message Settings** > |  **Multimedia Message** >  **Multimedia Templates** >  **New**).

- **Signature:** Allows you to insert your own created signature. For further details.

- ▶ **More:** Allows you to insert vCard, vCalendar, vNote, vTask or Contact.

### Note

vCard, vCalendar, vNote and vTask are created by the Address Book, Calendar, Notepad, and Tasks functions, respectively. Go to the Tools and Address Book sections in this Manual for more detailed information.

## Using Options

While entering text, press the right soft key  **Options**.

**Insert** allows you to insert **Symbol, Picture, Audio, Video, template** or more. You can also take new picture or record new audio/video to insert.

**Writing language** allows you to set the text entry language to English, Spanish.

- **Save to Drafts:** Saves the message to Drafts.
- **Cancel Message:** Allows you to exit the text input mode without saving your message.

## Sending a Message



After completing a message, using **Insert** and/or **Options**, press  **Send To** to select a recipient.

- Enter the recipient(s). For more options, press the left soft key  **Options**. In this menu, you can choose from the following options:
  - **Enter Number:** Allows you to enter the phone number using the keypad.
  - **Enter Email:** Allows you to enter an email address instead of a phone number.

# Messages

- **Insert Symbol:** Allows you to enter symbols.
- **Caller Groups:** Displays Contacts Groups.
- **Recent Messages:** Choose a Contact from Recent Messages.
- **Recent Calls:** Choose a Contact from Recent Calls.
- **Delivery Options:** Allows you to set the options for Add Cc, and Add Bcc.
- **Edit Message:** Go back to the message editing mode.
- **Save to Draft:** Saves the selected message to Drafts.
- **Writing language:** allows you to set the text entry language to English, Spanish.
- **Cancel Message:** Allows you to cancel the message.



## Inbox

You will be alerted when you receive a message. New messages are stored in the Inbox. In the Inbox, you can identify each message by icons. If you are notified that you have received a multimedia message, you can download the whole multimedia message by selecting it in the Inbox menu. To reach the Inbox, from the standby screen, press the left soft key  **Menu** >  **Messages** >  **Inbox**.

- ▶ **Add to Address Book:** You can save the sender's phone number in the Contact List.
- ▶ **Delete:** You can delete the selected message.
- ▶ **Forward:** You can forward the selected message to another person.

- ▶ **Copy to Phone/Copy to SIM:** You can copy to Phone or SIM depending on where the text message is stored.
- ▶ **Select Multiple:** You can select multiple messages.
- ▶ **Message Details:** You can view the following information about received messages: message Type, Subject, From, and message Time.
- ▶ **Delete All Read Messages:** You can delete all read messages.

## Drafts

Allows you to view and edit the messages saved as drafts. To access drafts, from the standby screen, press the left soft key  **Menu**,  **Messages**, and  **Drafts**. The following options are available for the Drafts folder:

- ▶ **Select Multiple:** Allows you to select multiple messages to delete.
- ▶ **Message Details:** Allows you to view the details of the message.



# Messages

## Outbox

Outbox is the storage place for recently sent messages. When you press the  [SEND] key, you can call the recipient of the selected message.

If the message is not sent from the Outbox, you will receive a sound alert along with a Message Sending Failure notice on the screen.

Another attempt will be made to send the failed message and after two unsuccessful attempts, the message will no longer be sent automatically. In order to send the message that has failed, you must press the left soft key  **Resend** to resend the message.

To access the Outbox, from the standby screen, press the left soft key  **Menu**,  **Messages**, and  **Outbox**.

The following options are available for the Outbox folder:

- ▶ **View Status:** Shows the status of each message.
- ▶ **Delete:** Deletes the selected message.
- ▶ **Edit:** Allows you to edit the selected message.
- ▶ **Select Multiple:** Allows you to select multiple messages to delete.
- ▶ **Message Details:** Allows you to view the details of the message.

## Vicemail

This menu provides you with a quick way of accessing your voice mailbox (if provided by your network).

A shortcut for checking your voicemail is available. To quickly check your voicemail when in standby mode, press and hold the  key.

### Note

Please check with your network service provider for details of their service in order to configure the handset accordingly.

## Message Settings

To access and configure your Message Settings, from the standby screen, press the left soft key

 **Menu**,  **Messages**, and  **Message Settings**.

## Message Alert

Allows you to set the Sounds, Volume, and Alert Type.

## Save To

Allows you to choose whether to save to the SIM Card or the Phone.

## Signature

Allows you to create, edit, and delete your signature, which can be configured to be sent out with your outgoing messages.

## Text Message

Allows you to set preferences for text messages.

# Messages

The following options are available:

- ▶ **Text Templates:** Predefined messages that can quickly be sent. Press the right soft key  **Options** to access the following available options:
  - **Send:** Allows you to send the selected template via Message.
  - **Delete:** Allows you to delete the selected template message.
  - **Edit:** Allows you to edit the selected template message.
  - **Delete All:** Deletes all messages in the folder.
- ▶ **Message Center Number:** Allows you to view and edit the phone number for the Message Center. Do not edit unless instructed to do so by your service provider.
- ▶ **Email Gateway:** Allows you to view and edit the Email Gateway. Do not edit unless instructed to do so by your service provider.

- ▶ **Insert Signature:** Allows you to insert your signature in outgoing messages.

## Multimedia Message

Allows you to set your preferences for multimedia messages.

The following options are available:

- ▶ **Multimedia Templates:** Allows you to add, edit, and delete multimedia templates. Press the left soft key  **Options** to access the following available options:
  - **Send:** Allows you to send the selected message via Multimedia Message.
  - **Delete:** Allows you to delete the selected template message.
  - **Edit:** Allows you to edit the selected template message.

- **Rename:** Allows you to rename the selected template message.
- **Delete All:** Allows you to delete all the messages at one time.

## **Voicemail Number**

This menu allows you to set the Voicemail Center Number if this feature is supported by . Please check with for details of their service in order to configure the handset correctly.

## **Service Message**

Allows you to configure your settings to determine if you would like to receive service messages.



# Recent Calls

This menu allows you to see the list of recently received calls. To access Recent Calls, from the standby screen, press the left soft key

 **Menu**, and  **Recent Calls**.

You can access the list of All Calls/ Missed Calls/ Dialed Calls and Received Calls.

# Games & Apps

This menu allows you to download or access the various games and applications.

To access the Games & Apps, from the standby screen, press the left soft key  **Menu**, and  **Games & Apps**.

# E-Mail

## Sending an email using your new account

To send/receive an email, you should set up an email account.

- 1 Press **Menu**, select **E-Mail** and choose the account you want to use.
- 2 From Options choose **Write e-mail** and a new email window will open.
- 3 Enter address in To field then Write a subject line and press down navigation key.
- 4 Enter your message using the keypad then Press Ok to send the email.

## Retrieving your email

- 1 Press **Menu** and select **E-mail**.
- 2 Select the account you want to use.
- 3 Select **Inbox**.
- 4 Choose **Refresh** and the phone will connect to your email account and retrieve your new

## Message folders

Press **Menu** and select **E-mail**. The folder structure used on your LG-530G should be self-explanatory.

**Write e-mail** - Create your new message.

### Mailboxes

**Inbox** - All the e-mails you receive are placed into your Inbox. From here you can reply, forward and more.

**Drafts** - If you don't have time to finish writing a e-mail, you can save what you have written so far in here.

**Outbox** - This is a temporary storage folder while e-mail are being sent or stores the messages that are failed to sent.

**Sent** - Copies of all the e-mail you send are kept into your Sent folder.

**Phone Trash** - All the e-mail you remove are placed into your Phone Trash.

# Changing your email settings

- 1 Press **Menu**, choose **E-mail > Options > Mailboxes > Accounts**.
- 2 Select the account you want to use.
- 3 Select Options then settings from options then you can adapt the following settings:

**Accounts** - You can edit e-mail account settings.

**Schedule** - Choose the time period during when the Push Email will be active.



**Notification** - Choose whether or not to be alerted to new emails.

**Default Account** - Choose which account to compose e-mail by default.

**Signature** - Create an email signature and switch this feature on.

# Music

## Music

You can access Music by pressing the left soft key  **Menu**,  **Music**.

Music Player

- ▶ **All Songs:** Allows you to view all the songs in your music library.
- ▶ **Playlists:** Allows you to create your own playlists.
- ▶ **Artists:** Shows the list of artists of all the songs in your music library, and shows all the songs by a chosen artist.
- ▶ **Albums:** Shows the list of albums of all the songs in your music library, and shows all the songs on a chosen album.
- ▶ **Genres:** Shows the list of genres of all the songs in your music library, and shows all songs of a specific genre.

- ▶ **Shuffle Songs:** Allows you to play all the songs in your music library in random order.

### Tip!

The music player plays formats such as MP3, AAC, AAC+, and WMA.

### Note

Copyrights of music files may be protected by copyright and intellectual property laws. Please ensure that you adhere to the applicable Terms of Use of materials laws prior to downloading or copying files. To play songs from or transfer songs to SD card, the SD card should have some empty space.



**Up to 512MB card:** Require 3MB empty space



**Up to 4GB card:** Require 6MB empty space

**Up to 16GB card:** Require 20MB empty space (Up to 1000 songs)

## Playing Music

To listen to music that you have transferred to your phone, follow these quick easy steps:

- 1 Press the left soft key  **Menu** to open the Main Menu.
- 2 Press  **Music Player** to view your options. You can select from Now Playing, All Songs, Playlists, Artists, Albums and Genres to select your Music or you can just select Shuffle Songs to shuffle your collection.

- Press  to **Play/Pause** a selected song. While playing, press the up or down navigation keys to change the volume and the left or right navigation keys to go to the previous or next song.
- While playing music, press the left soft key  **Option** to access other phone functions while music is playing.

### Note

Files under 300kb are stored as ringtone files.

# Music

## Adding Music To Your Handset

Music files can be added to your handset by using one or more of the following methods:

- Download music and ringtones over the network directly to your device.
- From your PC using other music subscription services, such as Napster or eMusic.

### Note

Some sites are data intensive (i.e. previews via streaming) so the user should be enrolled in an unlimited data plan before using these services to avoid per-use data charges.

Additional charges may apply when downloading music, ringtones etc.

## Transferring Music using your PC

### Before You Get Started

To transfer music from your PC to your device, you will need the following:

- Music on your PC in one of these formats:  
MP3, .AAC, AAC+ or WMA ,aac,imy,mid,midi,mmf,mp3,3ga,wav,m4a, wma,amr (except ringtone)
- A MicroSD™ card\*  
(supports up to 16GB cards)

- USB data cable\*

\* MicroSD™ card and USB data cable sold separately; go to [att.com/wireless](http://att.com/wireless) for details.

### Note

This device is not compatible with iTunes and/or iTunes files.

## Drag and Drop Music Using LG-530G As A Mass Storage Device

- 1 Insert a microSD™ memory card into the phone and make sure it is powered on.
- 2 Connect the device to a PC using a LG-530G USB data cable.
- 3 Access My Computer on the PC.
- 4 Locate the phone and double-click it to open.

### Note

The PC will automatically assign a drive letter.

- 5 Browse the files in a new window for desired music files.
- 6 Drag and drop the desired music content from the PC window to the “Storage Card” window.
- 7 Disconnect the device from the cable.
- 8 Access the Music Player on the phone.

## Additional Music Services

There may be other music applications preloaded or available for your phone that allow you to:

- Identify the name, artist, and album to a song from a song sample.
- Listen to the latest Classic, jazz, pop, rock anywhere you go.
- View the latest music videos.
- View music news and information.
- Cut custom-made ringtones from the favorite parts of your favorite songs, etc.



# Music

**Note**

Some sites are data intensive (i.e. previews via streaming) so the user should be enrolled in an unlimited data plan before using these services to avoid per-use data charges.

Additional charges may apply for downloading content or use of these services.

# Camera

To access Camera & Recordings, from the standby screen, press the left soft key  **Menu**, and  **Camera**.

## Take Photo

Using the camera module built into your phone, you can take pictures of people or events while on the move. Additionally, you can send photos to other people in a picture message.

The following options will appear (as icons) at the bottom of the screen.

- ▶ **Album:** Allows you to see saved image and video files.
- ▶ **Video:** Allows you to switch to Camcorder mode.
- ▶ **Capture:** Allows you to capture the image.
- ▶ **Zoom:** Allows you to set the zoom level.
- ▶ **Brightness :** Allows you to set the Brightness.

The right soft key  **Settings** will bring up the following options:

## Preview Tab

- ▶ **Image Size:** The resolution of the image can be captured in 1280\*960, 640\*480, 320\*240.
- ▶ **Color Effects:** Allows you to choose from Color, Mono, Sepia, or Negative.
- ▶ **White Balance:** Set the White Balance as Auto, Daylight, Cloudy, Illuminate, or Indoors.
- ▶ **Night Mode:** On/Off
- ▶ **Timer:** Timer can be set to Off, 3 Seconds, 5 Seconds, or 10 Seconds.
- ▶ **Shot Mode**
  - **Normal Mode:** This set as normal camera mode.
  - **Continuous Shot:** This is great for taking photos of moving objects or at sporting events.

# Camera

The continuous shot is only available in QVGA(320x240) mode and can be set to Off or 3/6/9 shots per event.

- ▶ **Image Quality:** The quality of the captured image can be set to Super Fine, Fine, or Normal.

## Others Tab

- ▶ **Shutter Tones:** You can choose from Tone 1, Tone 2, Tone 3, or Off.
- ▶ **Reset Settings:** Allows you to set the Camera to the default settings.

## Using Zoom

In Take Photo mode, you can Zoom in/out by using the up/down side volume keys. The maximum zoom scale depends on the resolution as follows.

Resolution	Zoom scale
1280*690	Not Available
640*480	Level 1 ~ Level 10
320*240	Level 1 ~ Level 10

## Record Video

Allows you to record a video clip with your phone. Before starting to record, press the right soft key  **Settings** to configure your settings.

The following options will appear (as icons) at the bottom of the screen.

- ▶ **Album:** Allows you to see saved image and video files.
- ▶ **Photo:** Allows you to switch to the Camera function so you to take a picture.
- ▶ **Record:** Allows you to begin recording the video.
- ▶ **Zoom:** Allows you to set the zoom level.

- ▶ **Brightness** : Allows you to set the Brightness.

The right soft key 

**Settings** will bring up the following options:

### Preview Tab

- ▶ **Video Size**: Allows you to select a video size between 320\*240 or 176\*144.
- ▶ **Color Effects**: Allows you to choose from Color, Mono, Sepia, or Negative.
- ▶ **White Balance**: Set the White Balance as Auto, Daylight, Cloudy, Illuminate, or Indoors.
- ▶ **Video Quality**: Allows you to set video quality to Super Fine, Fine, or Normal.
- ▶ **Duration**: Set the recording duration to General Mode or MMS Video mode.

### Others Tab

- ▶ **Recording Tones: On/Off**
- ▶ **Reset Settings**: Allows you to set the Camcorder to the default settings.

#### Note

In Video Record mode, you can adjust the zoom scale by using the up/down side volume keys. The maximum zoom scale depends on the resolution as follows.

Resolution	Zoom scale
320*240	Level 1~Level 10
176*144	Level 1~Level 10

# Camera

## Camera Album

Allows you to view the pictures and videos that are captured with the camera. When a file is highlighted, the following options are available when you press the right soft key

### Options:

For image file:

**Use As/Send/Print Via  
Bluetooth/Delete/Rename/View  
Full Screen/File Information.**

For video file:

**Send Via/Delete/Rename/Select  
Multiple/File Information**

# My Folder

## Audio

To access Audio, from the standby screen, press the left soft key

 **Menu**,  **My Folder**, and  **Audio**.

- ▶ **Shop Tones** Allows you to buy ring tones.
- ▶ **RingBack Tones** This menu option allows to manage your Answer Tones.
- ▶ **Record Voice:** Allows you to record voice notes.
- ▶ Saved audio files are displayed in the list.

## Picture

To access Picture, from the standby screen, press the left soft key



 **Menu**,  **My Folder**, and  **Picture**.

- ▶ **Shop Wallpapers:** Connects to 's Color Graphics download site.
- ▶ **Take Picture:** The picture files saved on your phone and

memory card (if inserted) are displayed.

## Video

To access Video, from the standby screen, press the left soft key

 **Menu**,  **My Folder**, and  **Video**.

- ▶ **Record Video:** The video files saved on your phone and memory card (if inserted) are displayed.



### Note

DRM sometimes restricts some functions, such as send and edit.

# My Folder

## Other Files

When you receive files of an undefined format (such as .vcs, .vcf, etc.) via email, the files are saved in this folder.

To access Other Files, from the standby screen, press the left soft key  **Menu**,  **My Folder**, and  **Other Files**.

The following options are available:

- ▶ **Send Via:** Send the selected file via Bluetooth or MMS.
- ▶ **Delete:** Allows you to delete the selected file.
- ▶ **Move:** Allows you to move the selected file to another folder.
- ▶ **Copy:** Allows you to copy the selected file to another folder.
- ▶ **Rename:** Allows you to edit the name of the selected file.
- ▶ **Select Multiple:** Allows you to select multiple files at once to perform various functions.

- ▶ **Sort By:** Allows you to sort the files by Name, Date, and Type.
- ▶ **File Information:** Allows you to view information about the selected file or used memory space on your phone or memory card.

## File Manager

This function allows you to view the content in your internal phone memory and the external memory card.

To access File Manager, from the standby screen, press the left soft key  **Menu**,  **My Folder**, and  **File Manager**.

# Tools

## Alarm Clock



The alarm function allows you to set up multiple separate alarms. You can also set the time, repetition interval, and alarm tone. If there is no alarm setting, press the left soft key  **New** to add a new alarm.

To access Alarm Clock, from the standby screen, press the left soft key  **Menu**,  **Tools**, and  **Alarm Clock**.

## Alarm Options

- ▶ **Time:** Input your desired alarm time by specifying the hour and minutes.  
Set Time: You can also choose a predefined amount of time (15 Minutes Later, 30 Minutes Later, 45 Minutes Later, 1 Hour Later, Off).
- ▶ **Repeat:** Select the desired repeat mode (Once, Daily, Mon ~ Fri, Sat ~ Sun, Except Holiday,

Select Weekday).

- ▶ **Alarm Tone:** Press  **List** to access the list of available Alarm Tones.
- ▶ **Volume:** Set the volume of the alarm using up/down key.
- ▶ **Type:** Select the Ring Alert Type between **Ring/ Vibrate/ Ring & Vibrate** and **Vibrate after Ring**.
- ▶ **Memo:** Input alarm name. Press the Right soft key  **Save** to save your new Alarm.
- ▶ **Snooze interval:** Select the snooze interval between **5 Minutes/ 15 Minutes/ 30 Minutes/ 45 Minutes / 1 Hour and Off**.

## Calendar









When you enter this menu, a calendar will be displayed. The red square cursor is used to locate a particular day. The bottom bar





# Tools

on the calendar indicates saved schedules (if any) for that day. This function helps you keep track of your schedule. The phone can sound an alarm tone if it has been set for a specific schedule item.

The chart below shows the keys that can be used to navigate the Calendar:

Key	Description
 key /  key	Weekly
 key /  key	Daily
 key /  key	Annually
 key /  key	Monthly

To access Calendar, from the standby screen, press the left soft key  **Menu**,  **Tools**, and  **Calendar**.

The following options are available when a Calendar event is selected from the Calendar menu.

► **Search:** Allows you to search the saved schedule(s).

► **Delete:** Allows you to delete the selected schedule.

► **Send Schedule Via:** Sends the selected schedule by Text Message, Multimedia Message, or Bluetooth.

► **Set Holiday:** Allows you to set specific dates to display as Holidays on your calendar.

► **Selective Delete:** Allows you to delete Old Schedules or All Schedules selectively.



► **View All:** Allows you to view all saved schedules.



► **Go to Date:** Allows you to jump to a specific date.

► **Select Multiple:** Allows you to select multiple schedules in the same day to delete or send to another person.

## Notepad



You can create up to a maximum of 30 memos.

To access Notepad, from the standby screen, press the left soft key  **Menu**,  **Tools**, and  **Notepad**.

- 1 Press the left soft key  **New** to create a new memo.
- 2 Input the memo and press  **Save** to save.

## Calculator

The Calculator function allows you to calculate simple mathematical equations.



To access Calculator, from the standby screen, press the left soft key  **Menu**,  **Tools**, and  **Calculator**.

## Tasks

This feature allows you to save and manage a task.

To access Tasks, from the standby screen, press the left soft key

 **Menu**,  **Tools**, and  **Tasks**.

- 1 To add a new task item, press the left soft key  **New**.
- 2 Input the Due Date, Note, Priority, and Status information for the new Task.
- 3 Press the left soft key  **Save** to save the Task item.

The following options are available in the Task list:



- ▶ **Mark 'Complete'**: Allows you to change the status of the selected task as Completed.
- ▶ **Edit**: Allows you to edit a saved task.
- ▶ **Delete**: Deletes the selected task.
- ▶ **Selective Delete**: Allows you to delete All Completed/All Past Tasks selectively.

# Tools

- ▶ **Send Task Via:** Enables the selected task to be sent via Text Message, Multimedia Message, or Bluetooth.
- ▶ **Select Multiple:** Allows you to select multiple Tasks.
- ▶ **View Calendar:** Allows you to view the Calendar.





## Stopwatch

This menu allows you to record the elapsed time of an event. The duration of an individual lap time (up to 20 laps) and the total time can also be displayed.

To access Stopwatch, from the standby screen, press the left soft key  **Menu**,  **Tools**, and  **Stopwatch**.



### ▶ New Time

- 1 To start timing, press  **Start**. The running time is displayed as HH.MM.SS.hh (hours, minutes, seconds, hundredths of a second).

- 2 During the timing, you can record an individual lap time by pressing the Left soft key  **Lap**. Up to 20 lap times can be recorded.
- 3 You can stop or restart timing by pressing  again.
- 4 To reset the stop watch, press  **Stop** to stop the time, then press the left soft key  **Reset**.

## Tip Calculator



This feature allows you to quickly and easily calculate the tip amount based on the total bill as well as the split of the total bill based on the number of people.

To access Tip Calculator, from the standby screen, press the left soft key  **Menu**,  **Tools**, and  **Tip Calculator**.

## Unit Converter

This function allows you to convert units of measurement.

There are 6 types of units that can be converted: Area, Length, Weight, Temperature, Volume, and Velocity.

To access Unit Converter, from the standby screen, press the left soft key  **Menu**,  **Tools**, and  **Unit Converter**.

### Note

You can input a decimal by pressing the  key.

## Record Voice

Allows you to record an audio clip to your phone. The recorded audio file is saved automatically in the Audio menu.

To access Record Voice, from the standby screen, press the left soft key  **Menu**,  **Tools**,

and  **Record Voice**.

The following options are available when you press the left soft key

### **Options:**

- ▶ **Record Mode:** Sets the recording mode to either MMS Mode or General Mode.
- ▶ **Quality:** Allows you to set the quality of an audio clip. You can set it to Fine, Normal, or Economy
- ▶ **Set Storage Defaults:** You can set the default storage of the recorded audio to the Phone Memory or the Memory Card.

Pressing the right soft key

 Gallery will take you to the Audio gallery.

# Browser



Mobile Web is one of the services provided by and it gives you access to all the cool things you can do with your wireless phone.

## Note

Check the availability of services, pricing, and tariffs with your network operator and/or the service provider whose service you wish to use. Service providers will also give you instructions on how to use their services.

Please contact your service provider to open an Internet account.

## Launch the Browser

To launch the browser from the standby screen, press the right soft key  **Menu** and 

## Browser.

Once connected, the homepage is displayed.

To exit the browser at any time, press the  [END] key.

## Using the Browser

Once you are connected to the Internet, the following menu options are available when you press the left soft key  **Options:**

- ▶ **Zoom:** Allows you to zoom in/out for better look.
- ▶ **Home:** Directs you to the homepage.
- ▶ **Enter URL:** Allows you to enter URL you desire to visit.
- ▶ **Send Link:** Allows you to send link

- ▶ **Bookmarks:** You can add or save the current page to Bookmarks or view the list saved under Bookmarks.
- ▶ **Navigation Mode** (sub -Back, Forward, Refresh)
- ▶ **Search Text:** Allows you to search the text.
- ▶ **Recent Page:** Allows you to view your history of recently viewed web sites.
- ▶ **Settings:** Allows you to set options for web pages, appearance.

## Menus for the Browser

You can surf the Internet using either the phone keys or the Browser menu.



## Using the Navigation Keys

When surfing the Internet, the navigation keys function similarly from when the phone is on standby mode.

# Settings

## Audio & Ringtones

This menu allows you to configure the audio and ringtone settings for your phone.

To access Audio & Ringtones, from the standby screen, press the left soft key  **Menu**,  **Settings**, and  **Audio & Ringtones**.

## Ringtone

- ▶ **Sounds:** Allows you to set a sound as the ringtone for your phone.
- ▶ **Volume:** Allows you to control your Ringtone volume.
- ▶ **Alert Type:** Supports 3 ring alert types: Ring, Ring and Vibration, and Ring after Vibration.

- ▶ **Increasing Ringtone:** Allows you to enable or disable the Increasing Ringtone function, which is played when you receive an incoming call.

### Note

Full length music tracks cannot be set as either ringtones or message tones.

## Message Tone

- ▶ **Sounds:** Allows you to set a sound as your message tone.
- ▶ **Volume:** Allows you to control your Message Tone volume.
- ▶ **Alert Type:** Supports 6 message alert types: Ring Once, Ring Every 2 Min., Ring Every 15 Min., Ring & Vibrate, Vibrate, and Silent.

## Alert Tone

- ▶ **Sounds:** Allows you to select a set of alert tones. Supports 2 alert tone types: Alert Tone 1 and Alert Tone 2.
- ▶ **Volume:** This menu allows you to control your Alert Tone volume.
- ▶ **Alert Type:** You can select to turn Alert Tones to Ring or Silent.

## Keypad Tone

This menu option allows you to select a tone that the phone sounds when a key is pressed on the dialpad. You can select an option from **Beep and Voice and set the volume**.



## Multimedia

This menu allows you to control your Multimedia volume.

## Call

This menu allows you to control your Call volume.

## Phone Settings

This menu allows you to configure the Phone Settings. To access Phone Settings, from the standby screen, press the left soft key  **Menu**,  **Settings**, and  **Phone Settings**.

## Date & Time

- ▶ **Set Date:** This allows you to enter the day, month, and year. You can set to Auto Update with the Auto Update menu.
- ▶ **Date Format:**
  - ddd, MMM DD (day, month date)
  - MM/DD/YYYY (month/date/year)
  - DD/MM/YYYY (date/month/year)
  - YYYY/MM/DD (year/month/date)



# Settings

- ▶ **Set Time:** This allows you to enter the current time. You can choose the time format via the Time Format menu option.
- ▶ **Time Format:** 12 Hours/24 Hours
- ▶ **Auto Update:** Allows you to set the phone to automatically update the time and date according to the current local time zone.

## Languages

Allows you to change the language for the display text on your phone. This change will also affect the Language Input mode.

## Set Hotkeys

Allows you to change the preferences on the Hotkeys that are currently assigned for your navigation keys (when in standby mode).

## Auto Key Lock

This allows you to set the amount of time before your keys lock automatically.

## Set Flight Mode

This allows you to only use the phone's features that do not require the use of the wireless network when you are in an airplane or in places where the wireless network is prohibited. If you set the flight mode on, the flight mode icon will be displayed on the screen instead of the network signal icon.

- ▶ **On:** You cannot make (or receive) any calls, including emergency calls, or use other features that require network coverage.
- ▶ **Off:** You can deactivate the flight mode to access the network.

## Security

Various codes and passwords are used to protect the features and settings of your phone.

- ▶ **Phone Lock:** You can use a security code to avoid unauthorized use of the phone. If you set the Phone Lock to When Power On, the phone will request a security code whenever you switch the phone on. If you set the Phone Lock to When SIM Card changed, your phone will request a security code only when you change your SIM Card. If you set the Phone Lock to Lock Phone Now, your phone will lock immediately.
- ▶ **Change Codes:** The Change Codes feature allows you to change your current password to a new one. You must enter the current password before you can specify a new one. You can change the access codes for:  
**Security Code**

- ▶ **PTT Key Lock:** Allows you to enable or disable the PTT Key Lock.

## Reset Settings

This function allows you to restore factory settings. To do this, you need the security code.

- ▶ **Master Reset:** Restores the phone settings (e.g.: Audio, Display, Language, Date & Time, Bluetooth Settings) to default values.
- ▶ **Master Clear:** Deletes downloaded/user created contents (e.g.: images, videos) from the phone and the external memory card.
- **Phone**
  - Deletes all downloaded/user created images and audios from the phone memory.
  - Deletes personal information stored in the phone memory (e.g.: Address Book, Messages,

# Settings

Tasks, Alarm, Calendar Schedules).

- Restores the settings stored in the phone memory to the default values.
- **Memory Card:** Deletes all contents from the external memory card.

## Display

This menu allows you to configure your Display settings.

To access Display, from the standby screen, press the left soft key

 **Menu**,  **Settings**, and  **Display**.

## Shop Wallpapers

Connects to 's Color Graphics download site.

## Wallpapers

This menu allows you to set a picture or color as your background.

## Fonts

You can configure the font size and color of the font that your phone uses.

## Clocks & Calendar

This feature allows you to select a Clock or Calendar to display on the standby screen.

## Brightness

You can set the brightness of the display screen.

## Backlight Timer

Use this to set the duration of the display backlight.

## Color Schemes

Allows you to change the whole look of your phone display to a Black or White scheme.

## Menu Styles

You can set the main menu style to Icon or List view.

## Call

This menu allows you to configure your Call settings.

To access Call, from the standby screen, press the left soft key



 **Menu**,  **Settings**, and  **Call**.

## Send My Number



This network service allows you to set your phone number to be displayed or hidden from the person you are calling. You can select Set by Network if you prefer to have different settings for different service providers.

## Answer Mode

This allows you to determine how to answer the phone.

► **Any Key:** Allows you to answer an incoming call by pressing any key, except the  [END] key, side volume keys, or the right soft key  **Silent**.

# Settings

- ▶ **Send Key Only:** Allows you to only answer an incoming call by pressing the  [SEND] key or left soft key  **Accept.**

## Time & Cost

Allows you to view information about Call Duration and Data Counter.

## TTY

Allows you to enable TTY Mode in order to contact other TTY devices. Select from **TTY Full/TTY Talk/TTY Hear/TTY Off.**



## Hearing Aid

Select from On/Off.

# Bluetooth

Your phone has built-in Bluetooth wireless technology, which makes it possible for you to connect your phone wirelessly to other Bluetooth devices such as a hands-free device, PC, laptop, or other phones. The devices registered in your phone can only be connected one at a time (To make a connection to the same type of device or change Bluetooth preferences, disconnect the existing device first).

You can also exchange, for example, business cards, calendar items, and pictures.

To access Bluetooth, from the standby screen, press the left soft key  **Menu**,  **Settings**, and  **Bluetooth.**

## Hands-free profile

This  appears when the hands-free profile is used between the hands-free device. This allows you to call using a Bluetooth connection.

## A2DP profile

This  appears when the A2DP profile is used between the stereo headset device and the phone. This allows you to listen to an audio clip. A2DP is the Advanced Audio Distribution Profile, which provides support for streaming either mono or stereo audio using Bluetooth.

## Hands-free + A2DP profile

This  appears when both profiles of the hands-free and the A2DP are used between the compatible device and the phone. This allows you to call and listen to an audio clip using a Bluetooth connection.

When using each device, see the manual that comes with the device.

## Note







We recommend that your phone and the Bluetooth device you are communicating with should be no more than 10 meters apart. The connection may be improved if there are no solid objects between your phone and the other Bluetooth device.

## Bluetooth Menu Options

- ▶ **Turn On/Off:** Allows you to turn your Bluetooth functionality on or off.
- ▶ **Search New Device:** This function allows you to search for and add new devices.

# Settings

## To pair with another device



- 1 From the standby screen, press the left soft key  **Menu**,  **Settings**, and  **Bluetooth**, and  **Search New Device**.
  - 2 If you want to stop searching, press the right soft key  **Stop**.
  - 3 All of the devices found are displayed.
  - 4 Select the desired device by pressing  **Add** and entering the password.
- ▶ **My Devices:** This function allows you to view the list of all devices that are paired with your phone.
  - ▶ **My Bluetooth Info:** This menu allows you to configure the profile for Bluetooth.
    - **My device visibility:** Allows you to set to be **Hidden** or

### Visible for 3 Minutes.

- **Device Name:** Allows you to change the handset's name which can be seen by other Bluetooth devices.
- **Supported Services:** Shows you all services that the handset supports.
- **My Bluetooth Address:** Allows you to check the **handset bluetooth address**.

## Memory

This menu allows you to configure your Memory settings.

To access Memory, from the standby screen, press the left soft key  **Menu**,  **Settings**, and  **Memory**.

## Used Space

This function shows the memory status of the handset and memory card (if inserted).

### ► **Phone Common**

This function shows the Memory Status of the phone and the memory being used by Audio, Image, Video, Multimedia Message, Java, and Others types of files.

### ► **Phone Reserved**

This function shows the status of the reserved memory used by Text Messages, Contacts, Calendar items, Tasks, and the Notepad.

### ► **Memory Card**

If your phone has a memory card in the card slot, you can save images, sounds, and videos onto it. You can check the current status of the external memory card in this memory status menu.

### ► **SIM Card**



This function shows the status of the SIM Card memory.

## **Set Storage Defaults**

This menu allows you to set the storage default location for internet downloads, Bluetooth transfers, and voice recordings. You can set each case separately or choose to set all of them at once.

## **Application Settings**

This Menu allows you to configure Application Settings.

To access Application Settings, from the standby screen, press the left soft key  **Menu**,  **Settings**, and  **Application Settings**.

## **Messages**

For more details, refer to Message Settings on page 25.

## **Browser**

This menu allows you to configure the Browser settings.



# Settings

## Accounts

This includes the network information used to connect the browser to the Internet. Select the desired account by highlighting it and pressing the left soft key  **Activate**. This will activate the account that will be used for future connections.

▶ **Activate:** Select the account among the list of accounts, so it can be used for future connections.

▶ **View:** Allows you to see the specific account information.

The following options will be available when you press on the right soft key  **Options:**

▶ **Edit:** Allows you to change the account information. This option is not available for the default Account.

▶ **Delete:** Allows you to delete the account.

▶ **New:** Allows you to create new account.

### Note

- You cannot edit and delete pre-installed accounts.
- In order to create a new account, please fill in the network information.
  1. Account Name: Name associated with new account.
  2. Homepage: Homepage URL.
- has provided default settings regarding account information.
- Creating or editing an account requires caution. The browser cannot connect to the Internet if the account information is incorrect.

## Appearance

You can choose the settings of the browser appearance (Text size, Character Encoding, Scrolling Control, Show Image, JavaScript).

## Cache

The web pages you have accessed are stored in the phone memory. This menu allows you to manage that function.

- ▶ **Clear Cache:** Remove all cached data in the memory.
- ▶ **Allow Cache:** Allows you to turn the memory cache on or off.

### Note

Cache is a type of buffer memory, which is used to store data temporarily, especially when it is online.

## Cookies

The information of services you have accessed are stored in what is called a Cookie.

From this menu, you can choose to Allow Cookies or to Delete Cookies that are already on your phone.

## Screen Settings

You can change the settings of the browser screen (Rendering mode, Zoom, Mini-Map).

## Security

A list of the available certificates is shown.

- ▶ **Certificates:** You can see the list of certificates and view them in detail.
- ▶ **Clear Session:** Removes the secure session.

# Settings

## Navigation Mode

You can change the methods of browser navigation.

- ▶ **4 Way Navigation:** The cursor of the browser moves scroll amounts or follows hyperlinks.
- ▶ **Mouse Pointer:** You can move the cursor like a mouse pointer.

## Secure Pop-up

You can activate or deactivate the pop-up which indicates a secure page.



## Browser Shortcut

If set to On, you can use the alternative browser (found in **Menu > My Stuff > Applications > Browser**) more quickly and conveniently with the key pad in the phone. If Browser Shortcut is on, the following shortcuts are available:

- |                   |                  |
|-------------------|------------------|
| 1. Enter URL      | 2. Recent Pages  |
| 3. Add This Page  | 4. Page Up       |
| 5. Full Screen    | 6. Page Overview |
| 7. Page Down      | 8. New Window    |
| 9. Search Text    | 0. Zoom In       |
| *. View Bookmarks | #. Zoom Out      |

## Phone Information

This menu is used to view My Numbers, Manufacturer, Model Name, Device ID, Hardware Version, Software Version, Language, and DM Client Version.

To access Phone Information, from the standby screen, press the left soft key  **Menu**,  **Settings**, and  **Phone Information**.

# Accessories

There are a variety of accessories available for your mobile phone, some of which may be sold separately. You can select these options according to your personal communication requirements. Consult your local dealer for availability.

## Travel Adapter

This adapter allows you to charge the battery. It supports standard US 120 Volt 60Hz outlets.



## Battery

Standard battery is available.



## Note

- Always use genuine LG accessories. Failure to do this may invalidate your warranty.
- Accessories may be different in different regions; please check with our regional service company or agent for further enquiries.

# For Your Safety

## Important Information

This user guide contains important information on the use and operation of this phone. Please read all the information carefully for optimal performance and to prevent any damage to or misuse of the phone. Any changes or modifications not expressly approved in this user guide could void your warranty for this equipment. Any changes or modifications not expressly approved by the manufacturer could void the user's authority to operate the equipment.

## Before You Start

### Safety Instructions

**WARNING!** To reduce the possibility of electric shock, do not expose your phone to high humidity areas, such as the bathroom, swimming pool, etc.

**Always store your phone away from heat.** Never store your phone in settings that may expose it to temperatures less than 32°F or greater than 104°F, such as outside during extreme weather conditions or in your car on a hot day. Exposure to excessive cold or heat will result in malfunction, damage and/or catastrophic failure.

**Be careful when using your phone near other electronic devices.** RF emissions from your mobile phone may affect nearby in adequately shielded electronic equipment. You should consult with manufacturers of any personal medical devices such as pacemakers and hearing aides to determine if they are susceptible to interference from your mobile phone. Turn off your phone in a medical facility or at a gas station. Never place your phone in a microwave oven as this will cause the battery to explode.

**IMPORTANT!** Please read the TIA SAFETY INFORMATION on page 78 before using your phone.

## Safety Information

Read these simple guidelines. Breaking the rules may be dangerous or illegal. Further detailed information is given in this user guide.

- ▶ Do not disassemble this unit. Take it to a qualified service technician when repair work is required.
- ▶ Keep away from electrical appliances such as TVs, radios, and personal computers.
- ▶ The unit should be kept away from heat sources such as radiators or cookers.
- ▶ Do not drop.
- ▶ Do not subject this unit to mechanical vibration or shock.
- ▶ The coating of the phone may be damaged if covered with wrap or vinyl wrapper.
- ▶ Use dry cloth to clean the exterior of the unit. (Do not use solvent such as benzene, thinner or alcohol.)
- ▶ Do not subject this unit to excessive smoke or dust.
- ▶ Do not keep the phone next to credit cards or transport tickets; it can affect the information on the magnetic strips.
- ▶ Do not tap the screen with a sharp object; otherwise, it may damage the phone.
- ▶ Do not expose the phone to liquid or moisture.
- ▶ Use the accessories like an earphone cautiously. Do not touch the antenna unnecessarily.

# For Your Safety

## Memory card information and care

- ▶ The memory card cannot be used for recording copyright-protected data.
- ▶ Keep the memory card out of the small children's reach.
- ▶ Do not leave the memory card in extremely hot location.
- ▶ Do not disassemble or modify the memory card.

## FCC RF Exposure Information

**WARNING!** Read this information before operating the phone.

In August 1996, the Federal Communications Commission (FCC) of the United States, with its action in Report and Order FCC 96-326, adopted an updated safety standard for human exposure to radio frequency (RF) electromagnetic energy emitted by FCC regulated

transmitters. Those guidelines are consistent with the safety standard previously set by both U.S. and international standards bodies.

The design of this phone complies with the FCC guidelines and these international standards.

## CAUTION

Use only the supplied and approved antenna. Use of unauthorized antennas or modifications could impair call quality, damage the phone, void your warranty and/or result in violation of FCC regulations. Do not use the phone with a damaged antenna. If a damaged antenna comes into contact with skin, a minor burn may result. Contact your local dealer for a replacement antenna.

# For Your Safety

## **Cautions for Battery**

- ▶ Do not disassemble.
- ▶ Do not short-circuit.
- ▶ Do not expose to high temperature:  
60°C (140°F).
- ▶ Do not incinerate.

## **Battery Disposal**

- ▶ Please dispose of your battery properly or bring to your local wireless carrier for recycling.
- ▶ Do not dispose in fire or with hazardous or flammable materials.

## **Adapter (Charger) Cautions**

- ▶ Using the wrong battery charger could damage your phone and void your warranty.
- ▶ The adapter or battery charger is intended for indoor use only.



Do not expose the adapter or battery charger to direct sunlight or use it in places with high humidity, such as the bathroom.

## **Avoid damage to your hearing**

- ▶ Damage to your hearing can occur if you are exposed to loud sound for long periods of time. We therefore recommend that you do not turn on or off the handset close to your ear. We also recommend that music and call volumes are set to a reasonable level.
- ▶ If you are listening to music while out and about, please ensure that the volume is at a reasonable level so that you are aware of your surroundings. This is particularly imperative when attempting to cross the street.

# Safety Guidelines

## TIA Safety Information

Provided herein is the complete TIA Safety Information for Wireless Handheld phones. Inclusion of the text covering Pacemakers, Hearing Aids, and Other Medical Devices is required in the owner's manual for CTIA Certification. Use of the remaining TIA language is encouraged when appropriate.

## Exposure to Radio Frequency Signal

Your wireless handheld portable telephone is a lowpower radio transmitter and receiver. When it is ON, it receives and also sends out radio frequency (RF) signals.

In August, 1996, the Federal Communications Commissions (FCC) adopted RF exposure guidelines with safety levels for handheld wireless phones. Those guidelines are consistent with the safety standards previously

set by both U.S. and international standards bodies:

ANSI C95.1 (1992) \*

NCRP Report 86 (1986)

ICNIRP (1996)

Those standards were based on comprehensive and periodic evaluations of the relevant scientific literature. For example, over 120 scientists, engineers, and physicians from universities, government health agencies, and industry reviewed the available body of research to develop the ANSI Standard (C95.1).

\* American National Standards Institute; National Council on Radiation Protection and Measurements; International Commission on Non-Ionizing Radiation Protection

The design of your phone complies with the FCC guidelines (and those standards).

## Antenna Care

Use only the supplied or an approved replacement antenna. Unauthorized antennas, modifications, or attachments could damage the phone and may violate FCC regulations.

## Phone Operation

**NORMAL POSITION:** Hold the phone as you would any other telephone with the antenna pointed up and over your shoulder.

## Tips on Efficient Operation

For your phone to operate most efficiently:

- ▶ Do not touch the antenna unnecessarily when the phone is in use. Contact with the antenna affects call quality and may cause the phone to operate at a higher power level than otherwise needed.

## Driving

Check the laws and regulations on the use of wireless phones in the areas where you drive. Always obey them. Also, if using your phone while driving, please:

- ▶ Give full attention to driving - driving safely is your first responsibility;
- ▶ Use hands-free operation, if available;
- ▶ Pull off the road and park before making or answering a call if driving conditions so require.

## Electronic Devices

Most modern electronic equipment is shielded from RF signals. However, certain electronic equipment may not be shielded against the RF signals from your wireless phone.

# Safety Guidelines

## Pacemakers

The Health Industry Manufacturers Association recommends that a minimum separation of 15cm (6 inches) be maintained between a handheld wireless phone and a pacemaker to avoid potential interference with the pacemaker. These recommendations are consistent with the independent research by and recommendations of Wireless Technology Research.

Persons with pacemakers:

- ▶ Should ALWAYS keep the phone more than 15cm (6 inches) from their pacemaker when the phone is turned ON;
- ▶ Should not carry the phone in a breast pocket.
- ▶ Should use the ear opposite the pacemaker to minimize the potential for interference.
- ▶ If you have any reason to suspect that interference is taking place, turn your phone

OFF immediately.

## Hearing Aids

Some digital wireless phones may interfere with some hearing aids. In the event of such interference, you may want to consult .

## Other Medical Devices

If you use any other personal medical device, consult the manufacturer of your device to determine if they are adequately shielded from external RF energy. Your physician may be able to assist you in obtaining this information.

## Health Care Facilities

Turn your phone OFF in health care facilities when any regulations posted in these areas instruct you to do so. Hospitals or health care facilities may use equipment that could be sensitive to external RF energy.

## **Vehicles**

RF signals may affect improperly installed or inadequately shielded electronic systems in motor vehicles. Check with the manufacturer or its representative regarding your vehicle.

You should also consult the manufacturer of any equipment that has been added to your vehicle.

## **Posted Facilities**

Turn your phone OFF in any facility where posted notices so require.

## **Aircraft**

FCC regulations prohibit using your phone while in the air. Turn your phone OFF before boarding an aircraft.

## **Blasting Areas**

To avoid interfering with blasting operations, turn your phone OFF when in a 'blasting areas or in areas posted: 'Turn off two-way radio'. Obey all signs and instructions.

## **Potentially Explosive Atmosphere**

Turn your phone OFF when in any area with a potentially explosive atmosphere and obey all signs and instructions. Sparks in such areas could cause an explosion or fire resulting in bodily injury or even death.

Areas with a potentially explosive atmosphere are often, but not always, marked clearly. Potential areas may include: fueling areas (such as gasoline stations); below deck on boats; fuel or chemical transfer or storage facilities; vehicles using liquefied petroleum gas (such as propane or butane);

# Safety Guidelines

areas where the air contains chemicals or particles (such as grain, dust, or metal powders); and any other area where you would normally be advised to turn off your vehicle engine.

## For Vehicles Equipped with an Air Bag

An air bag inflates with great force. DO NOT place objects, including either installed or portable wireless equipment, in the area over the air bag or in the air bag deployment area. If in-vehicle wireless equipment is improperly installed and the air bag inflates, serious injury could result.

## Safety Information

Please read and observe the following information for safe and proper use of your phone and to prevent damage. Also, keep the user guide in an accessible place at all the times after reading it.

- ▶ Do not disassemble or open crush, bend or deform, puncture or shred.
- ▶ Do not modify or remanufacture, attempt to insert foreign objects into the battery, immerse or expose to water or other liquids, expose to fire, explosion or other hazard.
- ▶ Only use the battery for the system for which it is specified.
- ▶ Only use the battery with a charging system that has been qualified with the system per IEEE-Std-1725-2006. Use of an unqualified battery or charger may present a risk of fire, explosion, leakage, or other hazard.

- ▶ Do not short circuit a battery or allow metallic conductive objects to contact battery terminals.
- ▶ Replace the battery only with another battery that has been qualified with the system per IEEE-Std-1725-2006. Use of an unqualified battery may present a risk of fire, explosion, leakage or other hazard.
- ▶ Promptly dispose of used batteries in accordance with local regulations.
- ▶ Battery usage by children should be supervised.
- ▶ Avoid dropping the phone or battery. If the phone or battery is dropped, especially on a hard surface, and the user suspects damage, take it to a service center for inspection.
- ▶ Improper battery use may result in a fire, explosion or other hazard.

- ▶ The phone shall only be connected to USB products that bear the USB-IF logo or have completed the USB-IF compliance program.

## **Charger and Adapter Safety**

- ▶ The charger and adapter are intended for indoor use only.

## **Battery Information and Care**

- ▶ Please dispose of your battery properly or take it to your local wireless carrier for recycling.
- ▶ The battery does not need to be fully discharged before recharging.
- ▶ Use only LG-approved chargers specific to your phone model since they are designed to maximize battery life.

# Safety Guidelines

- ▶ Do not disassemble or impact the battery as it may cause electric shock, short-circuit, and fire. Store the battery in a place out of reach of children.
- ▶ Keep the battery's metal contacts clean.
- ▶ Replace the battery when it no longer provides acceptable performance. The battery can be recharged several hundred times before replacement.
- ▶ Recharge the battery after long periods of non-use to maximize battery life.
- ▶ Battery life will vary due to usage patterns and environmental conditions.
- ▶ Use of extended backlighting, Mobile Web Browsing, and data connectivity kits affect battery life and talk/standby times.
- ▶ The self-protection function of the battery cuts the power of the phone when its operation is in an abnormal state. In this case, remove the battery from the phone, reinstall it, and turn the phone on.

## Explosion, Shock, and Fire Hazards

- ▶ Do not put your phone in a place subject to excessive dust and keep the minimum required distance between the power cord and heat sources.
- ▶ Unplug the power cord prior to cleaning your phone, and clean the power plug pin when it is dirty.
- ▶ When using the power plug, ensure that it is firmly connected. If it is not, it may cause excessive heat or fire.



- ▶ If you put your phone in a pocket or bag without covering the receptacle of the phone (power plug pin), metallic articles (such as a coin, paperclip or pen) may short-circuit the phone. Always cover the receptacle when not in use.
- ▶ Do not short-circuit the battery. Metallic articles such as a coin, paperclip or pen in your pocket or bag may short-circuit the + and – terminals of the battery (metal strips on the battery) upon moving. Short-circuit of the terminal may damage the battery and cause an explosion.
- ▶ book or subway ticket near your phone. The magnetism of the phone may damage the data stored in the magnetic strip.
- ▶ Talking on your phone for a long period of time may reduce call quality due to heat generated during use.
- ▶ When the phone is not used for a long period time, store it in a safe place with the power cord unplugged.
- ▶ Using the phone in proximity to receiving equipment (i.e., TV or radio) may cause interference to the phone.
- ▶ Do not use the phone if the antenna is damaged. If a damaged antenna contacts skin, it may cause a slight burn. Please contact an LG Authorized Service Centre to replace the damaged antenna.

## **General Notice**

- ▶ Using a damaged battery or placing a battery in your mouth may cause serious injury.
- ▶ Do not place items containing magnetic components such as a credit card, phone card, bank

# Safety Guidelines

- ▶ Do not immerse your phone in water. If this happens, turn it off immediately and remove the battery. If the phone does not work, take it to an LG Authorized Service Centre.
- ▶ Do not paint your phone.
- ▶ The data saved in your phone might be deleted due to careless use, repair of the phone, or upgrade of the software. Please backup your important phone numbers. (Ring tones, text messages, voice messages, pictures, and videos could also be deleted.) The manufacturer is not liable for damage due to the loss of data.
- ▶ When you use the phone in public places, set the ring tone to vibration so as not to disturb others.
- ▶ Do not turn your phone on or off when putting it in your ear.

## FDA Consumer Update

The U.S. Food and Drug Administration Centre for Devices and Radiological Health Consumer Update on Mobile Phones.

### **1. Do wireless phones pose a health hazard?**

The available scientific evidence does not show that any health problems are associated with using wireless phones. There is no proof, however, that wireless phones are absolutely safe. Wireless phones emit low levels of radiofrequency energy (RF) in the microwave range while being used. They also emit very low levels of RF when in the standby mode. Whereas high levels of RF can produce health effects (by heating tissue), exposure to low level RF that does not produce heating effects causes no known adverse health effects. Many studies of low level RF exposures

have not found any biological effects. Some studies have suggested that some biological effects may occur, but such findings have not been confirmed by additional research. In some cases, other researchers have had difficulty in reproducing those studies, or in determining the reasons for inconsistent results.

## **2. What is the FDA's role concerning the safety of wireless phones?**

Under the law, the FDA does not review the safety of radiation-emitting consumer products such as wireless phones before they can be sold, as it does with new drugs or medical devices. However, the agency has authority to take action if wireless phones are shown to emit radiofrequency energy (RF) at a level that is hazardous to the user. In such a case, the FDA

could require the manufacturers of wireless phones to notify users of the health hazard and to repair, replace, or recall the phones so that the hazard no longer exists. Although the existing scientific data do not justify FDA regulatory actions, the FDA has urged the wireless phone industry to take a number of steps, including the following:

- ▶ Support needed research into possible biological effects of RF of the type emitted by wireless phones;
- ▶ Design wireless phones in a way that minimizes any RF exposure to the user that is not necessary for device function; and
- ▶ Cooperate in providing users of wireless phones with the best possible information on possible effects of wireless phone use on human health.

# Safety Guidelines

The FDA belongs to an interagency working group of the federal agencies that have responsibility for different aspects of RF safety to ensure coordinated efforts at the federal level. The following agencies belong to this working group:

- ▶ National Institute for Occupational Safety and Health
- ▶ Environmental Protection Agency
- ▶ Occupational Safety and Health Administration (Administración de la seguridad y salud laborales)
- ▶ Occupational Safety and Health Administration
- ▶ National Telecommunications and Information Administration

The National Institutes of Health participates in some interagency working group activities, as well.

The FDA shares regulatory responsibilities for wireless phones with the Federal Communications Commission (FCC). All phones that are sold in the United States must comply with FCC safety guidelines that limit RF exposure. The FCC relies on the FDA and other health agencies for safety questions about wireless phones.

The FCC also regulates the base stations that the wireless phone networks rely upon. While these base stations operate at higher power than do the wireless phones themselves, the RF exposures that people get from these base stations are typically thousands of times lower than those they can get from wireless phones. Base stations are thus not the subject of the safety

questions discussed in this document.

### **3. What kinds of phones are the subject of this update?**

The term 'wireless phone' refers here to handheld wireless phones with built-in antennas, often called 'cell', 'mobile', or 'PCS' phones. These types of wireless phones can expose the user to measurable radiofrequency energy (RF) because of the short distance between the phone and the user's head. These RF exposures are limited by FCC safety guidelines that were developed with the advice of the FDA and other federal health and safety agencies. When the phone is located at greater distances from the user, the exposure to RF is drastically lower because a person's RF exposure decreases rapidly with increasing distance from the source. The so-called 'cordless phones', which have

a base unit connected to the telephone wiring in a house, typically operate at far lower power levels, and thus produce RF exposures far below the FCC safety limits.

### **4. What are the results of the research done already?**

The research done thus far has produced conflicting results, and many studies have suffered from flaws in their research methods. Animal experiments investigating the effects of radiofrequency energy (RF) exposures characteristic of wireless phones have yielded conflicting results that often cannot be repeated in other laboratories. A few animal studies, however, have suggested that low levels of RF could accelerate the development of cancer in laboratory animals. However, many of the studies that showed increased tumor development used animals that

# Safety Guidelines

had been genetically engineered or treated with cancer causing chemicals so as to be pre-disposed to develop cancer in the absence of RF exposure. Other studies exposed the animals to RF for up to 22 hours per day.

These conditions are not similar to the conditions under which people use wireless phones, so we don't know with certainty what the results of such studies mean for human health. Three large epidemiology studies have been published since December 2000. Between them, the studies investigated any possible association between the use of wireless phones and primary brain cancer, glioma, meningioma, or acoustic neuroma, tumors of the brain or salivary gland, leukemia, or other cancers. None of the studies demonstrated the existence of any harmful health effects from

wireless phone RF exposures. However, none of the studies can answer questions about long-term exposures, since the average period of phone use in these studies was around three years.

## **5. What research is needed to decide whether RF exposure from wireless phones poses a health risk?**

A combination of laboratory studies and epidemiological studies of people actually using wireless phones would provide some of the data that are needed. Lifetime animal exposure studies could be completed in a few years. However, very large numbers of animals would be needed to provide reliable proof of a cancer promoting effect if one exists. Epidemiological studies can provide data that is directly applicable to human populations, but 10 or more

years follow-up may be needed to provide answers about some health effects, such as cancer. This is because the interval between the time of exposure to a cancer-causing agent and the time tumors develop - if they do - may be many, many years. The interpretation of epidemiological studies is hampered by difficulties in measuring actual RF exposure during day-to-day use of wireless phones. Many factors affect this measurement, such as the angle at which the phone is held, or which model of phone is used.

## **6. What is the FDA doing to find out more about the possible health effects of wireless phone RF?**

The FDA is working with the U.S. National Toxicology Program and with groups of investigators around the world to ensure that high priority animal studies are

conducted to address important questions about the effects of exposure to radiofrequency energy (RF). The FDA has been a leading participant in the World Health Organization International Electromagnetic Fields (EMF) Project since its inception in 1996. An influential result of this work has been the development of a detailed agenda of research needs that has driven the establishment of new research programs around the world. The project has also helped develop a series of public information documents on EMF issues. The FDA and the Cellular Telecommunications & Internet Association (CTIA) have a formal Cooperative Research and Development Agreement (CRADA) to do research on wireless phone safety. The FDA provides the scientific oversight, obtaining input from experts in government,

# Safety Guidelines

industry, and academic organizations. CTIA-funded research is conducted through contracts with independent investigators. The initial research will include both laboratory studies and studies of wireless phone users. The CRADA will also include a broad assessment of additional research needs in the context of the latest research developments around the world.

## **7. How can I find out how much radio frequency energy exposure I can get by using my wireless phone?**

All phones sold in the United States must comply with Federal Communications Commission (FCC) guidelines that limit radio frequency energy (RF) exposures. The FCC established these guidelines in consultation with the FDA and the other federal health and safety agencies. The FCC limit for RF exposure

from wireless telephones is set at a Specific Absorption Rate (SAR) of 1.6 watts per kilogram (1.6 W/kg). The FCC limit is consistent with the safety standards developed by the Institute of Electrical and Electronic Engineering (IEEE) and the National Council on Radiation Protection and Measurement. The exposure limit takes into consideration the body's ability to remove heat from the tissues that absorb energy from the wireless phone and is set well below levels known to have effects. Manufacturers of wireless phones must report the RF exposure level for each model of phone to the FCC. The FCC website (<http://www.fcc.gov/>) gives directions for locating the FCC identification number on your phone so you can find your phone's RF exposure level in the online listing.



## **8. What has the FDA done to measure the radio frequency energy coming from wireless phones?**

The Institute of Electrical and Electronic Engineers (IEEE) is developing a technical standard for measuring the radio frequency energy (RF) exposure from wireless phones and other wireless handsets with the participation and leadership of FDA scientists and engineers. The standard, 'Recommended Practice for Determining the Spatial- Peak Specific Absorption Rate (SAR) in the Human Body Due to Wireless Communications Devices: Experimental Techniques', sets forth the first consistent test methodology for measuring the rate at which RF is deposited in the heads of wireless phone users. The test method uses a tissuesimulating model of

the human head. Standardized SAR test methodology is expected to greatly improve the consistency of measurements made at different laboratories on the same phone. SAR is the measurement of the amount of energy absorbed in tissue, either by the whole body or a small part of the body. It is measured in watts/kg (or milliwatts/g) of matter. This measurement is used to determine whether a wireless phone complies with safety guidelines.

## **9. What steps can I take to reduce my exposure to radiofrequency energy from my wireless phone?**

If there is a risk from these products - and at this point we do not know that there is - it is probably very small. But if you are concerned about avoiding even potential risks, you can take a few simple steps

# Safety Guidelines

to minimize your exposure to radiofrequency energy (RF). Since time is a key factor in how much exposure a person receives, reducing the amount of time spent using a wireless phone will reduce RF exposure. If you must conduct extended conversations by wireless phone every day, you could place more distance between your body and the source of the RF, since the exposure level drops off dramatically with distance. For example, you could use a headset and carry the wireless phone away from your body or use a wireless phone connected to a remote antenna. Again, the scientific data do not demonstrate that wireless phones are harmful. But if you are concerned about the RF exposure from these products, you can use measures like those described above to reduce your

RF exposure from wireless phone use.

## **10. What about children using wireless phones?**

The scientific evidence does not show a danger to users of wireless phones, including children and teenagers. If you want to take steps to lower exposure to radiofrequency energy (RF), the measures described above would apply to children and teenagers using wireless phones. Reducing the time of wireless phone use and increasing the distance between the user and the RF source will reduce RF exposure. Some groups sponsored by other national governments have advised that children be discouraged from using wireless phones at all. For example, the government in the United Kingdom distributed leaflets containing such a

recommendation in December 2000. They noted that no evidence exists that using a wireless phone causes brain tumors or other ill effects. Their recommendation to limit wireless phone use by children was strictly precautionary; it was not based on scientific evidence that any health hazard exists.

## **11. What about wireless phone interference with medical equipment?**

Radio frequency energy (RF) from wireless phones can interact with some electronic devices. For this reason, the FDA helped develop a detailed test method to measure electromagnetic interference (EMI) of implanted cardiac pacemakers and defibrillators from wireless telephones. This test method is now part of a standard sponsored by the Association for the Advancement of Medical Instrumentation

(AAMI). The final draft, a joint effort by the FDA, medical device manufacturers, and many other groups, was completed in late 2000. This standard will allow manufacturers to ensure that cardiac pacemakers and defibrillators are safe from wireless phone EMI. The FDA has tested hearing aids for interference from handheld wireless phones and helped develop a voluntary standard sponsored by the Institute of Electrical and Electronic Engineers (IEEE). This standard specifies test methods and performance requirements for hearing aids and wireless phones so that no interference occurs when a person uses a 'compatible' phone and a 'compatible' hearing aid at the same time. This standard was approved by the IEEE in 2000. The FDA continues to monitor

# Safety Guidelines

the use of wireless phones for possible interactions with other medical devices. Should harmful interference be found to occur, the FDA will conduct testing to assess the interference and work to resolve the problem.

## 12. Where can I find additional information?

For additional information, please refer to the following resources:

FDA web page on wireless phones  
(<http://www.fda.gov/Radiation-EmittingProducts/>

[RadiationEmittingProductsandProcedures/HomeBusinessandEntertainment/CellPhones/default.htm](http://www.fda.gov/RadiationEmittingProductsandProcedures/HomeBusinessandEntertainment/CellPhones/default.htm))

Federal Communications Commission (FCC) RF Safety Program  
(<http://www.fcc.gov/oet/rfsafety>)

International Commission on Non-Ionizing Radiation Protection  
(<http://www.icnirp.de>)

World Health Organization (WHO) International EMF Project  
(<http://www.who.int/peh-emf/project/es>)

National Radiological Protection Board (UK)  
(<http://www.nrpb.org.uk/radiation>)

## 10 Driver Safety Tips

Your wireless phone gives you the powerful ability to communicate by voice almost anywhere, anytime. An important responsibility accompanies the benefits of wireless phones, one that every user must uphold.

When operating a car, driving is your first responsibility.

When using your wireless phone behind the wheel of a car, practice good common sense and remember the following tips:

- 1 Get to know your wireless phone and its features such as speed dial and redial. Carefully read

your instruction manual and learn to take advantage of valuable features most phones offer, including automatic redial and memory. Also, work to memorize the phone keypad so you can use the speed dial function without taking your attention off the road.

- 2** When available, use a hands-free device. A number of hands-free wireless phone accessories are readily available today. Whether you choose an installed mounted device for your wireless phone or a speaker phone accessory, take advantage of these devices if available to you.
- 3** Position your wireless phone within easy reach. Make sure you place your wireless phone within easy reach and where you can reach it without removing your eyes from the road. If you get an incoming call at an inconvenient time, if possible, let your voicemail answer it for you.

- 4** Suspend conversations during hazardous driving conditions or situations. Let the person you are speaking with know you are driving; if necessary, suspend the call in heavy traffic or hazardous weather conditions. Rain, sleet, snow and ice can be hazardous, but so is heavy traffic. As a driver, your first responsibility is to pay attention to the road.

- 5** Do not take notes or look up phone numbers while driving. If you are reading an address book or business card, or writing a “to-do” list while driving a car, you are not watching where you are going. It is common sense. Don’t get caught in a dangerous situation because you are reading or writing and not paying attention to the road or nearby vehicles.

- 6** Dial sensibly and assess the traffic; if possible, place calls when you are not moving or

# Safety Guidelines

before pulling into traffic. Try to plan your calls before you begin your trip or attempt to coincide your calls with times you may be stopped at a stop sign, red light or otherwise stationary. But if you need to dial while driving, follow this simple tip— dial only a few numbers, check the road and your mirrors, then continue.

- 7** Do not engage in stressful or emotional conversations that may be distracting. Stressful or emotional conversations and driving do not mix; they are distracting and even dangerous when you are behind the wheel of a car. Make people you are talking with aware you are driving and if necessary, suspend conversations which have the potential to divert your attention from the road.
- 8** Use your wireless phone to call for help. Your wireless phone is one of the greatest tools you can own to protect yourself and your family in dangerous situations — with your phone at your side, help is only three numbers away. Dial 911 or other local emergency number in the case of fire, traffic accident, road hazard or medical emergency. Remember, it is a free call on your wireless phone!
- 9** Use your wireless phone to help others in emergencies. Your wireless phone provides you a perfect opportunity to be a “Good Samaritan” in your community. If you see an auto accident, crime in progress or other serious emergency where lives are in danger, call 911 or other local emergency number, as you would want others to do for you.
- 10** Call roadside assistance or a special wireless non-emergency assistance number when necessary. Certain situations you encounter while driving

may require attention, but are not urgent enough to merit a call for emergency services. But you can still use your wireless phone to lend a hand. If you see a broken-down vehicle posing no serious hazard, a broken traffic signal, a minor traffic accident where no one appears injured or a vehicle you know to be stolen, call roadside assistance or other special non-emergency wireless number.

For more information, please call to 888-901-SAFE, or visit our website [www.ctia.org](http://www.ctia.org).

## ※ **Part 15.21 statement**

Change or Modifications that are not expressly approved by the manufacturer could void the user's authority to operate the equipment.

- .
- .
- .
- .

## ※ **Part 15.105 statement**

This equipment has been tested and found to comply with the limits for a class B digital device, pursuant to Part 15 of the FCC Rules. These limits are designed to provide reasonable protection against harmful interference in a residential installation. This equipment generates uses and can radiate radio frequency energy and, if not installed and used in accordance with the instructions, may cause harmful interference to radio communications. However, there is no guarantee that interference will not occur in a particular installation. If this equipment does cause harmful interference or television reception, which can be determined by turning the equipment off and on, the user is encouraged to try to correct the interference by one or more of the following measures:

- Reorient or relocate the receiving antenna.
- Increase the separation between the equipment and receiver.
- Connect the equipment into an outlet on a circuit different from that to which the receiver is connected.
- Consult the dealer or an experienced radio/TV technician for help.



## ※ **Part15 Class B Compliance**

This device and its accessories comply with part15 of FCC rules.

Operation is subject to the following two conditions:(1) This device & its accessories may not cause harmful interference. (2) This device & its accessories must accept any interference received, including interference that may cause undesired operation.

- 
- 
- 
- 

## ※ **Body-worn Operation**

This device has been tested for typical body-worn operations with the distance of 0.69inches (1.5cm) from the user's body. To comply with FCC RF exposure requirements, a minimum separation distance of 0.69inches(1.5cm) must be maintained from the user's body. For example, this device must be maintained from the user's body with an appropriate belt-clip accessory.[More than 0.69inches(1.5cm)] Additionally, Belt clips, holsters & other body-worn accessories may not contain metallic components.

# Sécurité

## Utilisation comme appareil portatif

Ce téléphone a été testé en vue d'une utilisation type comme appareil portatif, avec une distance de **1.5 cm (0.69 pouces)** entre l'arrière de l'appareil et le corps de l'utilisateur. Pour satisfaire aux exigences de la FCC en matière d'exposition aux radiofréquences, on doit maintenir une distance d'au moins **1.5 cm (0.69 pouces)** entre le corps de l'utilisateur et l'arrière du téléphone. Les pinces de ceinture, les étuis et autres accessoires semblables d'autres marques et contenant des composantes métalliques ne doivent pas être utilisés.

Les accessoires portatifs qui empêchent le maintien d'une distance de **1.5 cm (0.69 pouces)** entre le corps de l'utilisateur

et l'arrière du téléphone et qui n'ont pas été testés en vue d'une utilisation type comme accessoires portatifs peuvent ne pas satisfaire aux limites d'exposition aux radiofréquences stipulées par la FCC et, par conséquent, ne doivent pas être utilisés.

## **Conformité aux normes FCC Part 15 Class B**

Cet appareil et ses accessoires sont conformes aux normes FCC Part 15 Class B de la Federal Communications Commission et aux exigences pour appareils numériques ICES-003 Class B d' Industrie Canada.

Son fonctionnement est sujet aux deux conditions suivantes :

(1) Cet appareil et ses accessoires ne doivent pas provoquer de brouillage préjudiciable, et (2) cet appareil et ses accessoires doivent accepter toutes les interférences reçues, y compris celles pouvant causer un fonctionnement indésirable.

---

## FCC Hearing-Aid Compatibility (HAC) Regulations for Wireless Devices

On July 10, 2003, the U.S. Federal Communications Commission (FCC) Report and Order in WT Docket 01-309 modified the exception of wireless phones under the Hearing Aid Compatibility Act of 1988 (HAC Act) to require digital wireless phones be compatible with hearing-aids. The intent of the HAC Act is to ensure reasonable access to telecommunications services for persons with hearing disabilities.

While some wireless phones are used near some hearing devices (hearing aids and cochlear implants), users may detect a buzzing, humming, or whining noise. Some hearing devices are more immune than others to this interference noise, and phones also vary in the amount of interference they generate.

The wireless telephone industry has developed a rating system for wireless phones, to assist hearing device users to find phones that may be compatible with their hearing devices. Not all phones have been rated. Phones that are rated have the rating on their box or a label located on the box.

The ratings are not guarantees. Results will vary depending on the user's hearing device and hearing loss. If your hearing device happens to be vulnerable to interference, you may not be able to use a rated phone successfully. Trying out the phone with your hearing device is the best way to evaluate it for your personal needs.

M-Ratings: Phones rated M3 or M4 meet FCC requirements and are likely to generate less interference to hearing devices than phones that are not labeled. M4 is the better/higher of the two ratings.

T-Ratings: Phones rated T3 or T4 meet FCC requirements and are likely to generate less interference to hearing devices than phones that are not labeled. T4 is the better/ higher of the two ratings.

---

Hearing devices may also be rated. Your hearing device manufacturer or hearing health professional may help you find this rating. Higher ratings mean that the hearing device is relatively immune to interference noise. The hearing aid and wireless phone rating values are then added together. A sum of 5 is considered acceptable for normal use. A sum of 6 is considered for best use.

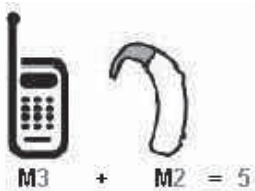

In the example to the left, if a hearing aid meets the M2 level rating and the wireless phone meets the M3 level rating, the sum of the two values equal M5. This should provide the hearing aid user with “normal usage” while using their hearing aid with the particular wireless phone. “Normal usage” in this context is defined as a signal quality that’s acceptable for normal operation.

The M mark is intended to be synonymous with the U mark. The T mark is intended to be synonymous with the UT mark. The M and T marks are recommended by the Alliance for Telecommunications Industries Solutions (ATIS). The U and UT marks are referenced in Section 20.19 of the FCC Rules. The HAC rating and measurement procedure are described in the American National Standards Institute (ANSI) C63.19 standard.

When you're talking on a cell phone, it's recommended that you turn the BT (Bluetooth) mode off for HAC.

**For information about hearing aids and digital wireless phones**

**Wireless Phones and Hearing Aid Accessibility**

<http://www.accesswireless.org/hearingaid/>

**FCC Hearing Aid Compatibility and Volume Control**

[http://www.fcc.gov/cgb/consumerfacts/hac\\_wireless.html](http://www.fcc.gov/cgb/consumerfacts/hac_wireless.html)

## ※ HAC statement

This phone has been tested and rated for use with hearing aids for some of the wireless technologies that it uses.

However, there may be some newer wireless technologies used in this phone that have not been tested yet for use with hearing aids.

It is important to try the different features of this phone thoroughly and in different locations, using your hearing aid or cochlear implant, to determine if you hear any interfering noise.

Consult your service provider or the manufacturer of this phone for information on hearing aid compatibility.

If you have questions about return or exchange policies, consult your service provider or phone retailer.

- 
- 
- 
- 

## ※ Hearing Aid mode (T-coil mode)

If you select on, users using hearing aids with T-coil will have better quality of sound. This T-coil mode will remain on during the voice call.