

CDMA Fixed Wireless Telephone User Guide

Model: LSI-1100

REVISED HISTORY

DATE	ISSUE	CONTENTS OF CHANGES	REMARK
2002/06/3	ISSUE1	Initial Release	

Blank Page

FCC RF EXPOSURE INFORMATION

WARNING! Read this information before using your phone



In August 1996 the Federal Communications Commission (FCC) of the United States with its action in Report and Order FCC 96-326 adopted an updated safety standard for human exposure to radio frequency electromagnetic energy emitted by FCC regulated transmitters. Those guidelines are consistent with the safety standard previously set by both U.S. and international standards bodies. The design of this phone complies with the FCC guidelines and these international standards.



Use only the supplied or an approved antenna. Unauthorized antennas, modifications, or attachments could impair call quality, damage the phone, or result in violation of FCC regulations.

Do not use the phone with a damaged antenna. If a damaged antenna comes into contact with the skin, a minor burn may result. Please contact your local dealer for replacement antenna.

To maintain compliance with FCC RF exposure requirements, maintain a 2.54 cm. separation distance between the user's body and the phone, including the antenna.

CONTENTS

Highlights.....	6
1. Important Information	7
1.1 Safety Information	7
1.2 Optimal Phone Performance	7
1.3 Care and Service.....	8
2. Introduction	9
2.1 Front View of the Telephone	9
2.2 LCD Display.....	10
2.3 Installation	11
2.4 Installation Steps	13
3. Basic Operation.....	17
3.1 Making a Call.....	17
3.2 Redialing Last Outgoing Number	17
3.3 Receiving a Call.....	18
3.4 Signal Strength.....	18
3.5 Missed Call Message	18
4. List of Menu State	19
4.1 Volume / Ring.....	20
4.1.1 Ring Volume	20
4.1.2 Key Volume.....	20
4.1.3 Ear Volume	20
4.1.4 Ring Select	21
4.2 Additional feature	21
4.2.1 Wake-up Time.....	21
4.2.2 Minute Alert.....	21
4.2.3 Set Rx call mode (not applicable in the Voice only model)	22
4.2.4 Backlight.....	22
4.2.5 Own number	22
4.3 Dial features	22
4.3.1 Hot Line	22
4.3.2 Hot Line Time	23
4.3.3 Auto Time-out.....	23
4.3.4 Speed Dial (enable / disable)	23
4.3.5 Key-tone Length	24
4.4 Security Features	24
4.4.1 Lock Mode Set.....	24
4.4.2 Clear Calls.....	25
4.4.3 Clear Memory	25
4.4.4 Emergency Call	25
4.4.5 Restriction Call Service.....	26

5. Functions while in a call	28
5.1 Mute	28
5.2 Ear Volume	28
6. Searching, Editing & Dialing	29
6.1 Retrieving Phone Number by Name	29
6.2 Retrieving Phone Number by Address.....	29
6.3 Retrieving Phone Number by NUMBER	31
6.4 Fast Searching.....	31
6.5 Clear Memory.....	31
7. SMS (Short Message Service)	32
7.1 Checking & Deleting Received Message.....	32
7.2 MSG Notification tone select.....	33
7.3 Message Sending	33
8. Beside Functions	36
8.1 Redial.....	36
8.2 Finding Last Call History	36
8.3 Flash	36
8.4 Safe mode.....	36
9. Storing Phone Number	37
9.1 Storing/Editing Phone Numbers.....	37
9.2 Finding Stored Phone Numbers.....	40
10. General Information	41

Highlights

Congratulations on your purchase of the LSI-1100 Fixed Wireless Telephone. This telephone has been designed to operate on the latest digital mobile communications technology. This technology has greatly enhanced voice clarity and can provide various advanced features.

The telephone provides:

- 5-line LCD Display with status indicator
- A choice of 10 ring sounds
- A menu driven interface with prompts for easy operation
- Last Number Redial
- Speed Dialing with a 99-number memory
- Dial tone
- ROH (Receiver Off-Hook) tone
- Adjustable Ring Volume
- Internal Battery Pack
- AC Power Supply
- Antenna
- Data Port for service and repair (not applicable in the voice only model)
- USB Connector for Data service (not applicable in the voice only model)
- Back light

1. Important Information

1.1 Safety Information

Warning

To reduce the risk of fire or electric shock, do not expose this product to rain or moisture. Do not use this product near swimming pools or other bodies of water.

IMPORTANT

Before installing or operating this product read this information.

1.2 Optimal Phone Performance

- Do not operate your product when holding the antenna, or when someone is within four inches (ten centimeters) of the antenna. Holding the antenna affects call quality and may cause the telephone to operate at a higher power level than needed.
- For the best call quality, keep the antenna free from obstructions and point the antenna straight up.
- Do not use the unit with a damaged antenna. Have your antenna replaced by a qualified technician immediately. Use only a manufacturer-approved antenna. Non-approved antennas, modifications, or attachments could impair call quality, damage the phone.
- RF energy may affect improperly installed or inadequately shielded personal medical devices such as pace markers, hospital monitor. Consult the manufacturer of any personal medical devices to determine if they are adequately shielded from external RF energy. Turn your terminal OFF in health care facilities when any regulations posted in the areas instruct you to do so. Hospitals or health care facilities may be using equipment that could be sensitive to external RF energy.
- If this equipment does cause harmful interference to radio or television reception, which can be determined by turning the equipment off and on, the user is encouraged to try to correct the interference by one or more of the following measures:
 - Reorient or relocate the receiving antenna
 - Increase the distance between the radio or television and the telephone.
 - Connect the equipment into an outlet on a circuit different from that to which the terminal is connected.
 - Consult you Authorized LGIC Dealer or an experienced radio/TV technician for help.
- Use only the battery, antenna and AC power supply provided by LGIC. Using any other type will invalidate the warranty.
- Only authorized personnel should service the phone and its accessories. Faulty installation or service may be dangerous and may invalidate the warranty.
- Do not use the unit in designated “no cellular phone use” area.
- Avoid exposure to high temperature or humidity.
- Avoid wetting the unit with any liquids. If the unit gets wet, turn the power off immediately and remove the battery and AC power supply. If the unit is inoperable, then return to the service agent for service.
- Avoid shock or impact.
- We recommend you to charge the internal battery before initial use. The battery may be discharged during delivery.

1.3 Care and Service

- Unplug the telephone from the wall outlet and remove antenna (or disconnect antenna cable) before cleaning. Do not use liquid or aerosol cleaners. Use a damp cloth for cleaning.
- If the unit fails for any reason, do not attempt to disassemble; contact the telephone service provider for assistance.
- If any of the following conditions exist; unplug the unit at the wall plug, remove battery, and call the service provider.
 - AC/DC Adapter is damaged or frayed.
 - Liquid has been spilled into the unit.
 - The unit has been exposed to rain or water.
 - The unit has been dropped or damaged.
 - The unit does not work normally by following the operating instructions.

2. Introduction

2.1 Front View of the Telephone

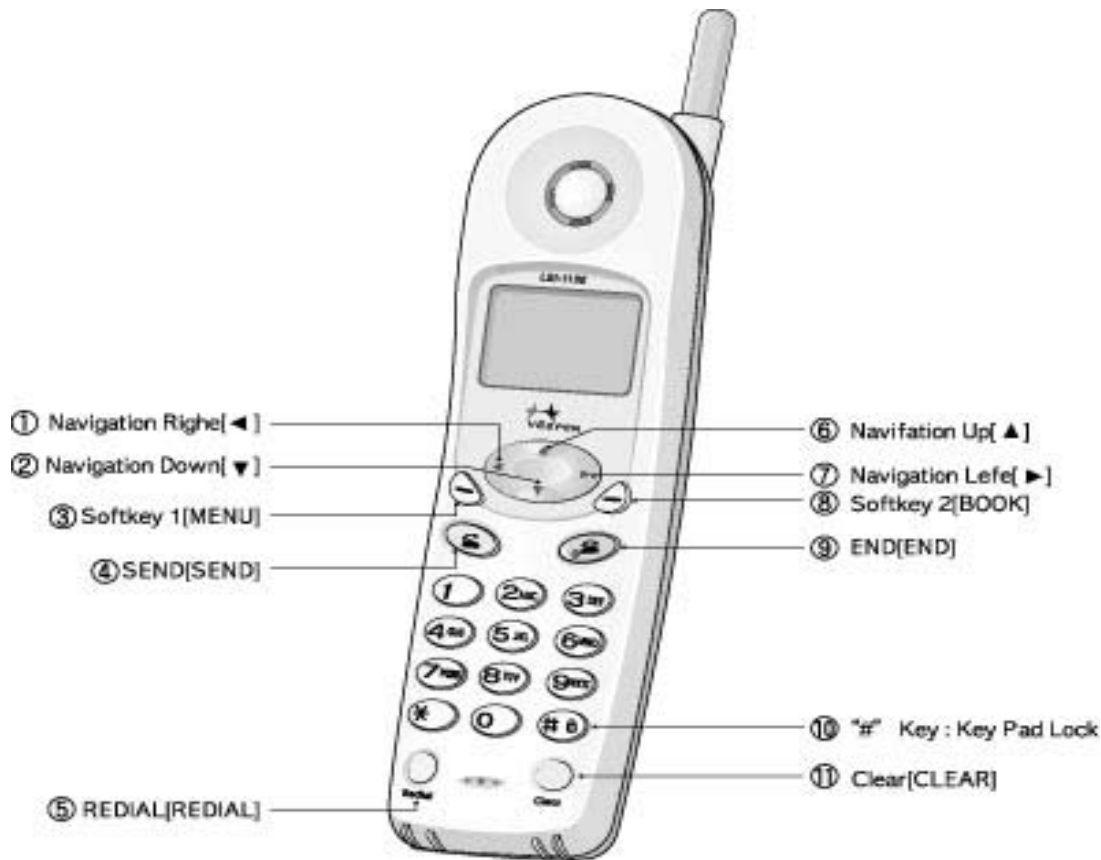

Navigation Left Key : Function for decreasing volume down.

Navigation Down Key : Function for scrolling down menu in menu state.

Softkey 1[MENU] Key : Activate a Menu state.

Send Key : Function key to call / Function for 3- way calling In call state

Redial Key : Function as a redialing

Navigation Up Key : Function for entering a MSG menu in idle state
/ Function for scrolling up menu in menu state.

Navigation Right Key : Function for increasing volume up.

Softkey 2[BOOK] Key : Activate a Book state.

End Key : Terminate a call or a menu state.

"# "Key : Function as a keypad lock.

Clear Key : Key to delete the last digit.

2.2 LCD Display

The LCD shows icons on the top of the LCD screen.

Different indicator appears based on the phone's operating mode.

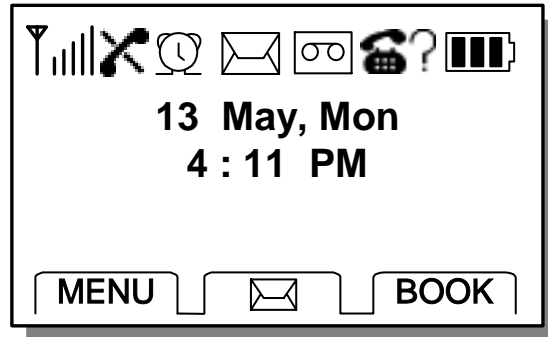

- 1) RSSI indicator : Indicates the signal strength in the service area.



- 2) No service : The phone is not receiving system signal.
- 3) In use : Displayed when call is in progress or the phone is in off-hook and dial tone heard.



:No service



: In use

- 4) Text message : Displayed when a text message is received.



- 5) Voice message : Displayed when a voice message is received.



- 6) Alarm : Displayed when wake up alarm time was setting.



- 7) Caller ID : Displayed when caller ID is received.



- 8) Battery charge level : Indicates charged battery level.



2.3 Installation

You should follow each step carefully as shown below in order to guarantee proper operation of CDMA Fixed Wireless Telephone.

STEP I. Check Components

- Fixed Wireless Terminal is supplied with the following standard unit and accessories;

1. LSI-110/1100 Main Unit with Antenna	-1EA-
2. Battery	-1EA-
3. User Guide	-1EA-
4. AC/DC Adapter	-1EA-
5. Charger	-1EA-

- Please make sure that these components are present before you begin the unit installation. And then compare the following figures and components. If components are missing or damage is found, contact the store where you purchased the unit immediately.

STEP II. Place the Terminal

- Place the terminal on the stable flat secure surface area (desk, table, etc.). Serious damage may result if the unit falls. Do not place the unit on, or within 1 meter of heaters or radiators. This unit is designed for desktop usage. Avoid direct exposure to the sun lights and damp area.
- Read the SAFETY INFORMATION located at the first part of this document before you place the terminal

STEP III. Connect Components (See the figures in "Installation Steps".)

- Open the battery cover, securely connect the battery cord, place the battery and close the cover.
- Connect the AC/DC Adapter cable to the DC input port located at the rear side of the charger.
 - . If it is good, beep tone is heard.
 - . If it is not good, you have to connect the adapter or battery, again.
- Please follow the below to get better voice quality;
 1. Keep away from electrical appliances such as TV, computer, radio and so on.
 2. Keep terminal in a high and central location with no obstructions, such as metal walls.
 3. Raise the integral antenna of terminal to get maximum strength of receive signal as shown figure at the next page.

STEP IV. Check the LCD Display

- After you follow the installation instruction **step I** to **step III**, please check the LCD for normal operation.
- If you may not see status of service, please repeat the 2nd instruction of **step III**. And conform Fixed Wireless Telephone to get the proper signal strength from service operator system.

The adapter type(with power cord) may be different by country adaptation.

2.4 Installation

2.4.1. Voice and Data supporting model.

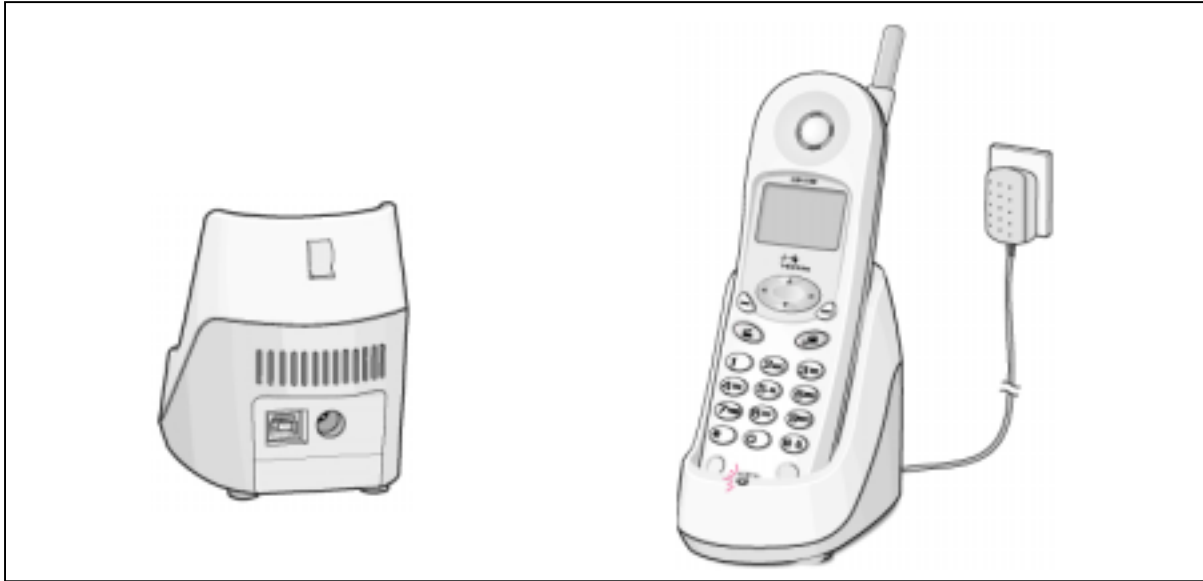

1 Connect the AC power supply line in the charger



2 Connect adapter to outlet.



3 Press and hold the power button to power on.



4 Pick down the handset on the charger to charge.



5 After charging the terminal, make a call.

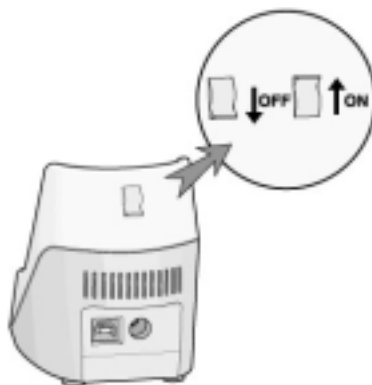

Lock Switch :

- Turn on the switch to fix phone with charger.
- Turn on the switch to make a call during Charging state.



The adapter type may be different by country adaptation.
Be careful of power voltage.

2.4.2. Voice only model.

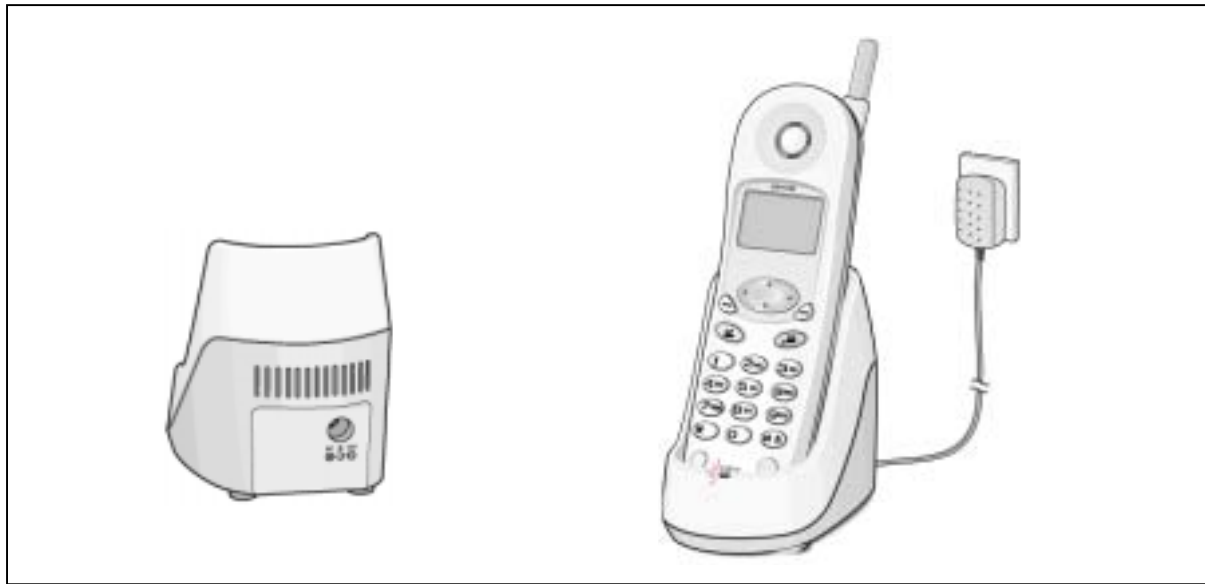

1 Connect the AC power supply line in the charger.

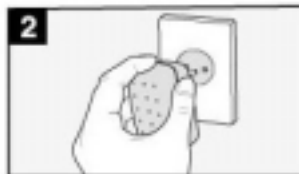

2 Connect adapter to outlet.



3 Press and hold the  button to power on.



4 Pick down the handset on the charger to charge.



5 After charging the terminal, make a call.



The adapter type may be different by country adaptation.
Be careful of power voltage.

2.4.3 Battery Replacement Step(Voice and Data supporting model)

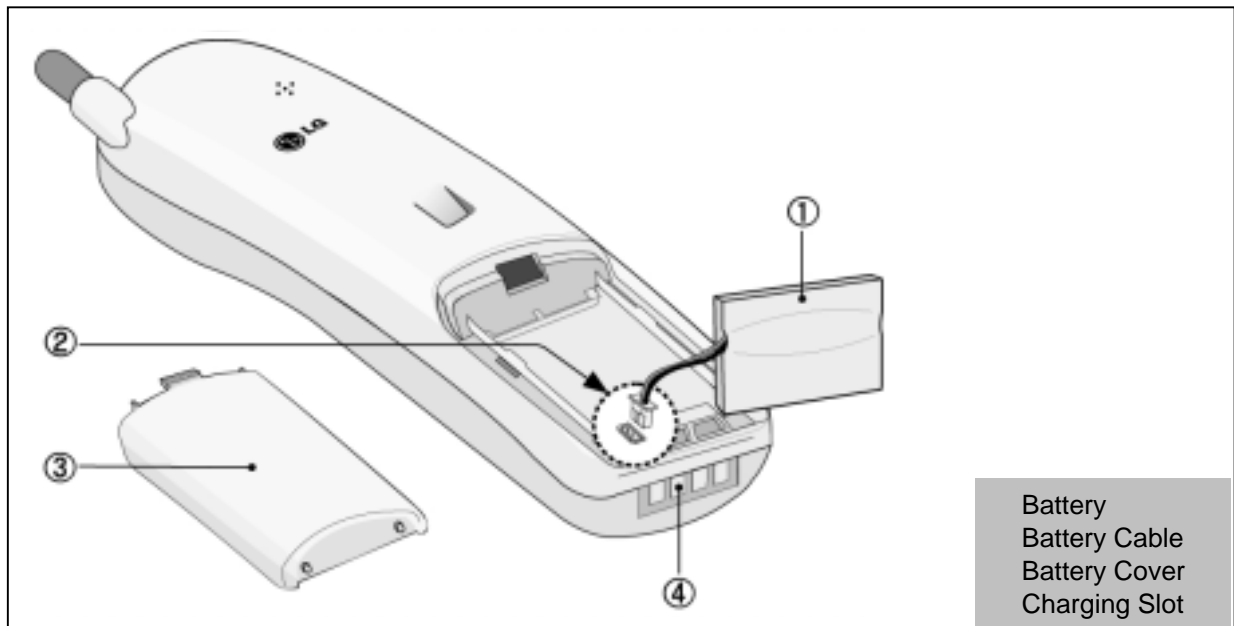

1 Open the battery cover of the unit.



2 Connect battery cable.



3 Insert battery in the unit (give care to polarity).



4 Replace the battery cover.



5 Press  button to make phone be powered on for 1 sec.

2.4.4 Battery Replacement Step(Voice only model)

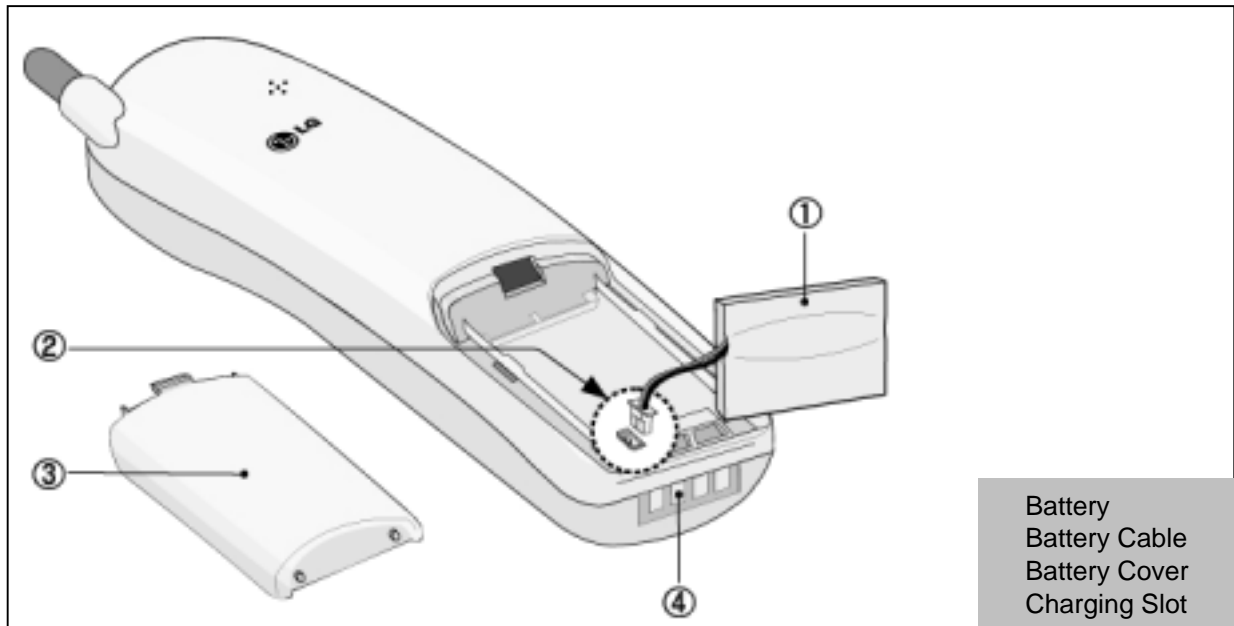

1 Open the battery cover of the unit.



2 Connect battery cable.



3 Insert battery in the unit (give care to polarity).



4 Replace the battery cover.



5 Press  button to make phone be powered on for 1 sec.

3. Basic Operation

3.1 Making a Call

1. Pick up the handset and press Send Key button
2. Listen for dial tone
3. Enter the phone number with area code if needed.

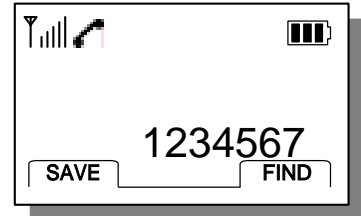

4. Wait for the Auto Time-out.

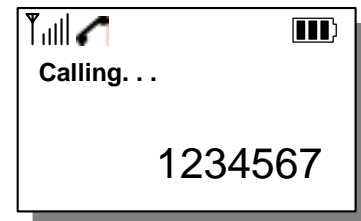

5. The call is connected and you can start conversation.
6. To disconnect the call, Press End button.

3.2 Redialing Last Outgoing Number

1. Pick up the handset and press Send Key button
2. Listen for dial tone.

Press **Redial** button. The last number that you called will be re-dialed.

- **If re-dialed number is a received number,(LSI-1100 Only)**
 1. @ will be attached in front of re-dial number
 2. You can't connect a line even if you redial.
- **Correcting dialing mistakes**
 1. Press **Clear** button shortly to erase the most recent digit.
 2. Press and hold **Clear** button for at least one second.
- If the phone is locked, enter the Lock Code
- If the call did not go through, press the hook switch and dial again.
- Battery icon is displayed only when the terminal is operating by battery without AC power.

3.3 Receiving a Call

1. When bell rings, Press Any Key or pick up the handset from the charger.

Press Send key at the Lock state.
2. Start conversation.
3. To disconnect the call, press End key or pick down the handset on the charger.

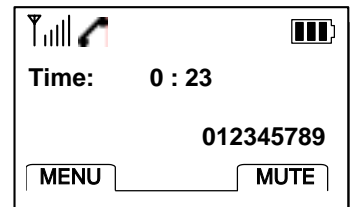
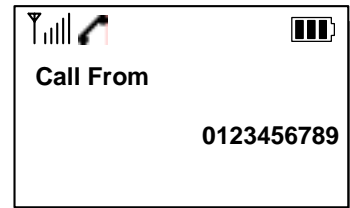

3.4 Signal Strength

The quality of calls depends on the signal strength in your area. The stronger the signal, the better the call quality. The signal strength icon indicates the current strength as a number of bars. You can see the antenna and bars according to the strength of received signal in the upper-left part.

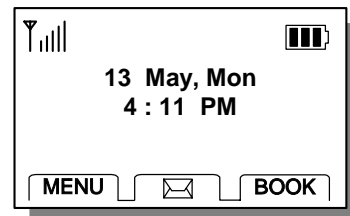

3.5 Missed Call Message

If a call is received and not answered for user's absence, You are informed that you have missed a call. The latest missed call time and number of missed call is displayed. Press **[OK]** to erase "Missed call" message.

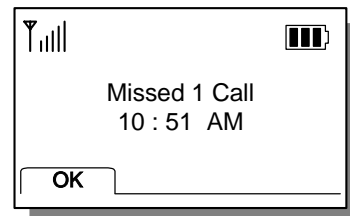

4. List of Menu State

Main Menu	Sub-Menu	Setting Value	Default
1. Volume / Ring	1. Ring Volume	4 steps	
	2. Key Volume	4 steps +silent	
	3. Ear Volume	4 steps	
	4. Ring Type	10 types	
2. Additional	1. Wake-up time	Off/Once/Always	
	2 .Minute alert	On/Off	
	3.Rx call mode	Voice / Fax for next / Always Fax / Modem for next / Always modem	Not applicable in the Voice only model
	4.Backlight	Always off / 10 seconds / 30 seconds	
	5.Own Number	Display own number	
3. Dial features	1. Hot Line	Off/On	
	2. Hot Line Time	2-9 Sec.	
	3. Auto time-out	2-9 Sec.	
	4. Speed Dialing	Enable/Disable	
	5. Key tone length	Normal/Long	
4. Security	1. Set Lock mode	On/Off	
	2. Clear calls	No/Yes	
	3. Clear memory	No/Yes	
	4. Emergency call	Local(3.ea)	
	5. Restrict call		
	5.1 restrict set	No restriction/restriction /emergency only	
	5.2 permit memory	Local(10.ea)	
	5.3 Deny memory	Local(10.ea)	
	6. new code	Create new lock code	

4.1 Volume / Ring

This menu allows you to adjust the various different volumes.

4.1.1 Ring Volume

The received tone when you receive a call can be adjusted.

- From the MENU

1. Press **[MENU]** + **1**(Volume/Ring)+ **1**(Ring Volume) in on-hook state.
2. Press **Navigation Left / Right Key** or **[NEXT]** to adjust ring volume.
3. Press **[OK]** to store the ring volume level

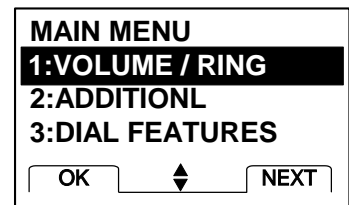

- By the **Volume** button

1. Press **Navigation Left / Right Key** to adjust ring volume in on-hook state

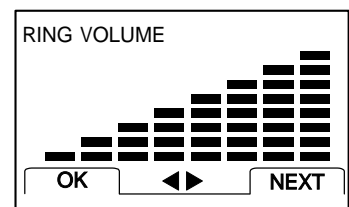

4.1.2 Key Volume

The tone when you press a key can be adjusted.

1. Press **[MENU]** + **1**(Volume/Ring) + **2**(Key Volume) in on-hook state.
2. Press **Navigation Left / Right Key** or **[NEXT]** to adjust key volume
3. Press **[OK]** to store the key volume level

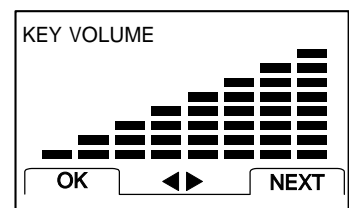

4.1.3 Ear Volume

The voice of the other party can be adjusted in on-hook state.

1. Press **[MENU]** + **1**(Volume/Ring) + **3**(Ear Volume) in on-hook state.
2. Press **Navigation Left / Right Key** or **[NEXT]** to adjust ear piece volume
3. Press **[OK]** to store the ear volume level.

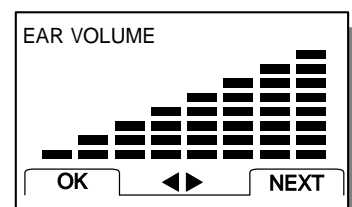

Press Navigation Left / Right Key to adjust volume during conversation.

4.1.3 Ring Select

You can select the various ring types.

1. Press **[MENU] + 1**(Volume/Ring) + **4**(Ring Type) in on-hook state.
2. Select a desired ring type with **Navigation Up / Down Key** or **[NEXT]**.
 - ✓ There are 10 different ring types.
 - ✓ Those are Standard, Option 1, Option 2, Option 3, Option 4, Habanera, Deutsch song, La Primavera, Oh! susanna, Beethoven

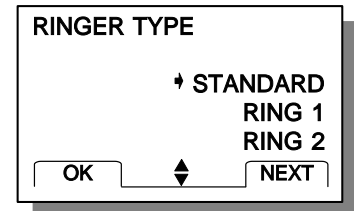

4.2 Additional feature

4.2.1 Wake-up Time

This function allows you to adjust Wake-up Time.

1. Press **[MENU] + 2**(ADDITIONAL) + **1**(Wake-up Time)

In on – hook State

2. Select **Off**, **Once** or **Always** by **[NEXT]** and press **[OK]**.

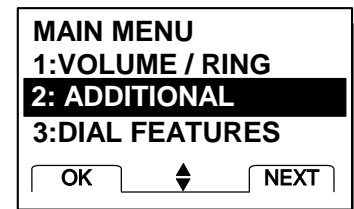

3. Press **[EDIT]** and set the time.

4. Select A.M. or P.M. by **[AM/PM]**.

5. If you want to modify the wrong time, press **Clear** button and set again.

6. Press **[OK]** to save and exit

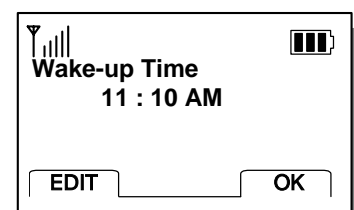
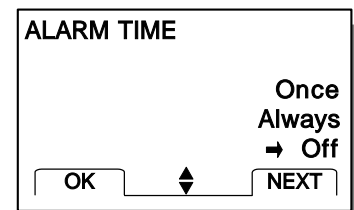

4.2.2 Minute Alert

Alerts you every minute during a call.

1. Press **[MENU] + 2**(ADDITIONAL) + **2**(Minute Alert)

In on – hook State

2. Select **On** or **Off** by **[NEXT]** or **Navigation Left / Right Key**.

3. Press **[OK]** to save and exit

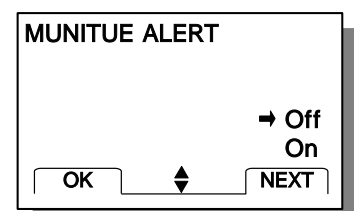

4.2.3 Set Rx call mode (not applicable in the Voice only model)

1. Press **[MENU]** + **2**(ADDITIONAL) + **3**(RX Call Mode) in on – hook State.
2. Select **Voice, Fax for next, Always Fax, Modem for next** by Navigation Left / Right Key or **[NEXT]** .
3. Press **[OK]** to save and exit.

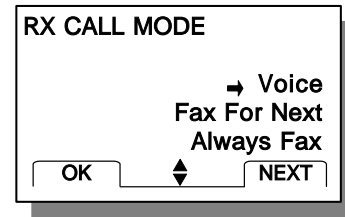

4.2.4 Backlight

1. Press **[MENU]** + **2**(ADDITIONAL) + **4**(Backlight) in on – hook State.
1. Select **Always off, 10 seconds, 30 seconds** by Navigation Up / Down Key or **[NEXT]** button.
2. Press **[OK]** to save and exit.

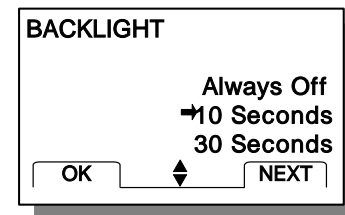

4.2.5 Own number

1. Press **[MENU]** + **2**(ADDITIONAL) + **5**(Own Number) in on – hook State.
2. Press **[OK]** to exit.

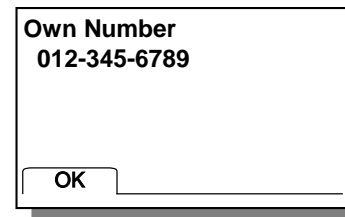

4.3 Dial features

4.3.1 Hot Line

1. Press **[MENU]** + **3** (DIAL FEATURES) + **1**(Hot Line) in on – hook state.
2. Select **On** or **Off** by **[NEXT]** or **Navigation Up / Down key**. and press **[OK]** to select.
3. Press **[EDIT]** to input Hot Line phone number.
4. Enter the Hot Line phone number.
5. Press **[OK]** to save and exit.

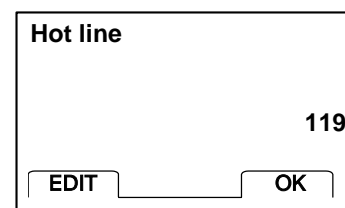
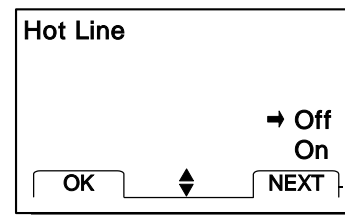
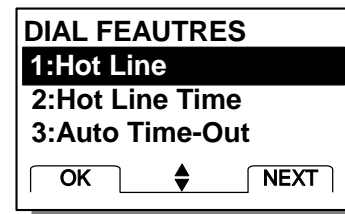

4.3.2 Hot Line Time

1. Press **[MENU]** + **3** (DIAL FEATURES) + **2**(Hot Line time) In on – hook Sate.

2. Select hot line connection time(2~9 sec.) by **[NEXT]** or **Navigation Up / Down key**.
3. Press **[OK]** to select.

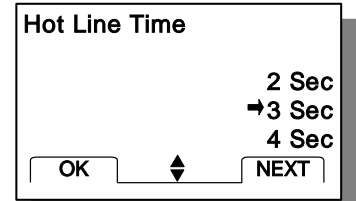

4.3.3 Auto Time-out

Setting the length of time the phone waits before automatically dialing a number. You can select this time between 2 and 9 second.

1. Press **[MENU]** + **3**(DIAL FEATURES) + **3**(Auto Timeout) in on – hook State.
2. Select Auto time-out second between 2 and 9 by **[NEXT]** or **Navigation Up / Down key**.
3. Press **[OK]** to select.

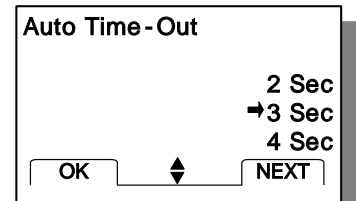

4.3.4 Speed Dial (enable / disable)

1. Press **[MENU]** + **3** (DIAL FEATURES) + **4**(Speed Dialing) in on – hook State.
2. Select **Enable** or **Disable** by **[NEXT]** or **Navigation Up / Down key** and press **[OK]** to save and exit.

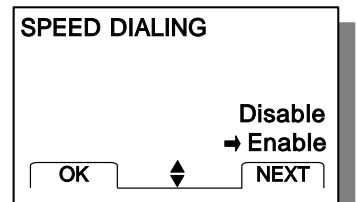

This function can be used when the Speed Dial is set to Yes.

- Speed Dial Function

1. You can store phone numbers in memory locations (1~99) and place a call.

2. Press the memory number (1 through 99) corresponding to the appropriate memory location, and hold for a few seconds.

4.3.5 Key-tone Length

Setting key beep playback length. Possible settings are **Normal** and **Long**.

1. Press **[MENU] + 3**(DIAL FEATURES) + **5**(KeyTone Length) in on – hook State.
2. Select **Normal** or **Long** by **[NEXT]** or **Navigation Up / Down key** and press **[OK]** to select.

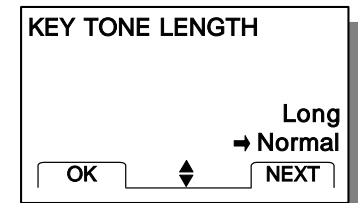
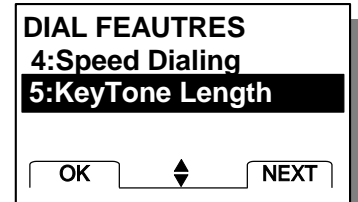

4.4 Security Features

4.4.1 Lock Mode Set

This function prevents your phone from being used without permission. Typical default value is 0000. Possible settings are **ON/OFF**. The **OFF** means that the phone is not locked. **ON** sets the phone locked immediately.

1. Press **[MENU] + 4** (SECURITY)
2. Enter your own 4 digit lock code
✓ When this product comes out, the default is 0000.
3. Press **1**(Set Lock Mode)
4. Select **Off, On** by **[NEXT]** or **Navigation Up / Down key**.
5. Press **[OK]** to save and exit.

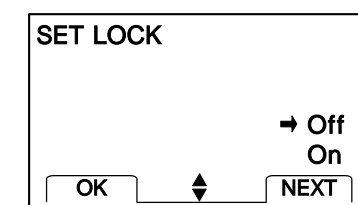
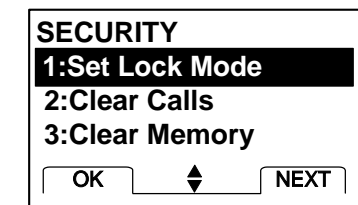
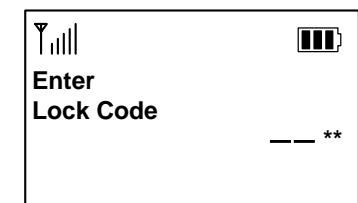

4.4.2 Clear Calls

When a previous outgoing or incoming call history is stored in a memory location, you can erase the all call history.

1. Do the above 1 and 2 steps of 4.4.1.
2. Press **2**(Clear Calls)

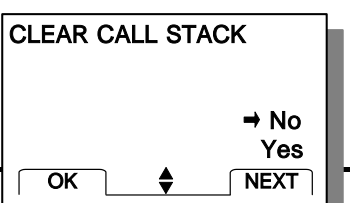

3. Press **[YES]** to erase all call history.

4.4.3 Clear Memory

When you want to delete phonebook memory, you can erase all phonebook memory.

1. Do the above step 1 and 2 of 4.4.1.
2. Press **3**(Clear Memory).
3. Press **[YES]** to erase all phone memory.

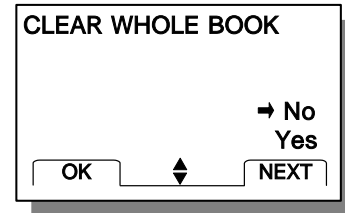

4.4.4 Emergency Call

Even if your phone is locked you can make calls to 3 emergency numbers.

1. Do the above step 1 and 2 of 4.4.1.
2. Press **4**(Emergency Call)
3. Press **[NEXT]** or **Navigation Up / Down key** to choose the number from 1 to 3.
4. Press **[EDIT]**.
5. Enter the emergency phone number.
6. Press **[OK]** to save the number.
7. Press **[NEXT]** or **Navigation Up / Down key** to edit others or Press **End** button to exit emergency call process.

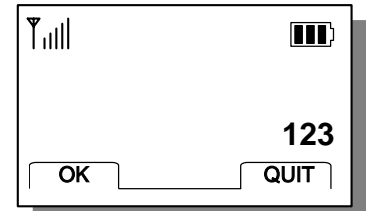
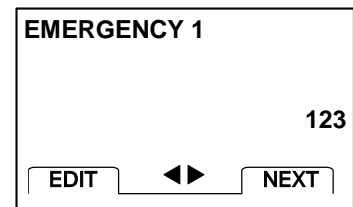

4.4.5 Restriction Call Service

This function is a convenient feature which enables user to restrict using any phone number. To forbid using any phone number, user must set the number in deny edit.

Can't use any phone number(max 32digits) started with the number saved in deny edit.

If user set the phone number in permit edit, can use any phone number (max 32digits) started with the number even if the phone number is set in deny edit.

Ex) example to restrict using the phone number started with "700" .

1. set "Restriction" in Restrict set menu (Menu 4.5.1)
 2. set "700" in deny edit. (Menu 4.5.3)
 3. set "700-1234" in permit edit.(Menu 4.5.2)
- Result : user can use the phone number started with "700-1234".

4.4.5.1 Restrict set

No restriction

This is a general function which has no any restrictions

Restriction

This is a function that you can set permitted phone number and denied phone number.

Emergency only

This is a function which enable you to call only emergency numbers.

1. Press **[MENU]** and **4**(SECURITY).

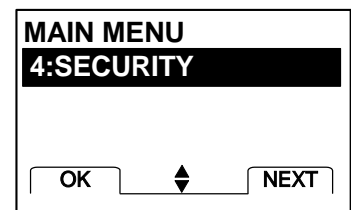

2. Enter a lock code using key pad.

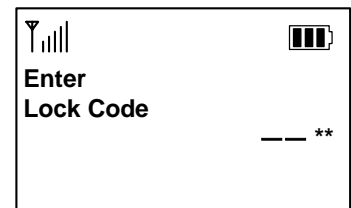

3. Press **5**(Restrict Call) and **1**(Restrict Set).

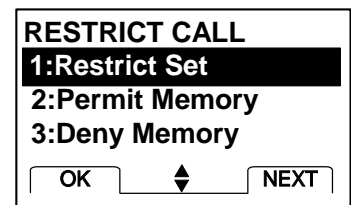

4. Select "No Restriction" , "Restriction" or "Emergency only" using **[NEXT]** or **Navigation Up / Down key** and press **[OK]**.

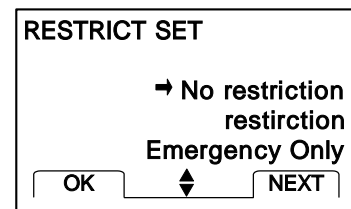

◆ Below 4.4.5.2 and 4.4.5.3 function can be used when the Restrict set is set to "Restriction".

4.4.5.2 Permit memory

You can call it if the phone numbers saved in permit edit though they were saved in deny edit. You can save 10 permit phone numbers.

1. Do the above step 1~2 of 4.4.1.

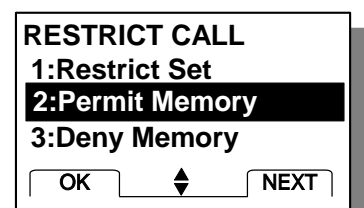

2. Press **5**(Restrict Call) and **2**(Permit Memory).

3. Press **[EDIT]** to edit permit phone number.

4. Enter the permit phone number.

5. Press **[OK]** to save and exit.

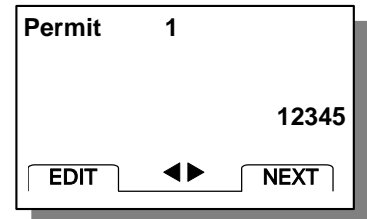

4.4.5.3 Deny memory

You couldn't call any phone numbers saved in deny edit.

You can save 10 deny phone numbers.

1. Do the above step 1~2 of 4.4.1

2. Press **5**(Restrict Call) and **3**(Deny Memory).

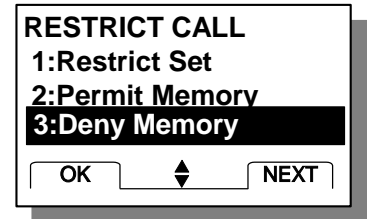

3. Press **[EDIT]** to edit deny number.

4. Enter the deny phone number.

5. Press **[OK]** to save and exit.

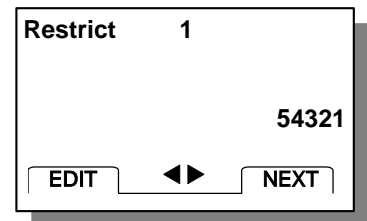

4.4.6 New Lock Code

You can change a new lock code(4digits).

1. Do the above step1~2 of 4.4.1.

2. Press **6**.(New Code)

3. Enter new lock code and press **[OK]** to save.

4. Enter new lock code again to confirm and press **[OK]** to save.

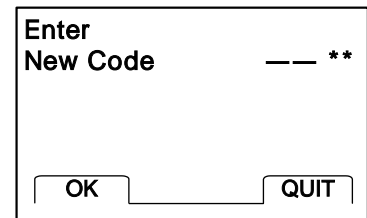

5. Functions while in a call

5.1 Mute

This function prevents your voice from being transmitted but you can still hear the other side.

1. Press **[MUTE]** button while in a call.

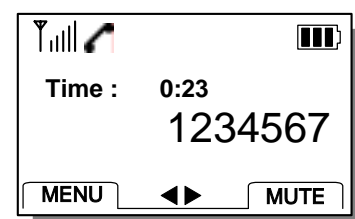

2. You could see “**MUTE**” message blinking on the right side of the LCD
3. To release Mute, Press [**TALK**] button.



5.2 Ear Volume

1. You may adjust ear volume while you are in a call.

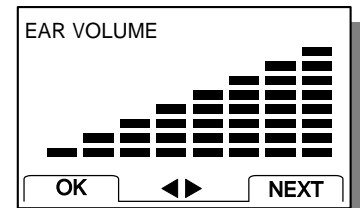

2. The **Navigation Left / Right Key** in the middle of the phone can be used to adjust ear volume.

6. Searching, Editing & Dialing

6.1 Retrieving Phone Number by Name

1. Press [**BOOK**] and 2(FROM MEMORIES)
2. Press 1 button to retrieve phone number by name.

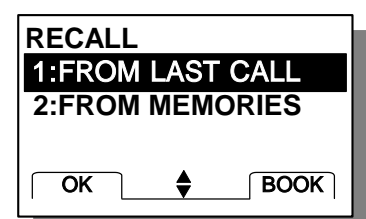

3. Enter the name that you want to look for and press **[FIND]**.

- ✓ At least two letters are recommended for quick search.

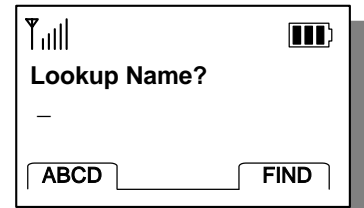

- ✓ Press **Navigation Up / Down Key** to scroll through the list of matches.

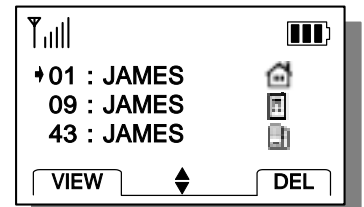

4. Press **[VIEW]** to see information in that location.

- ✓ Pick up handset and Press Send button to make a call.
- ✓ You can edit the phone number by pressing **[EDIT]** button.

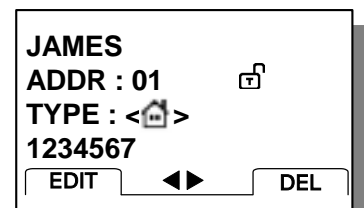

6.2 Retrieving Phone Number by Address

1. Press **[BOOK]** and **2**(FROM MEMORIES)

2. Press **2** button to retrieve a phone number by address.

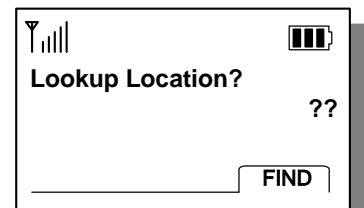

3. Enter a memory address to retrieve phone number.
(ex: If you enter a memory address, 01.)

- ✓ If there is no stored phone number in the memory location, "Empty Location" is displayed.
- ✓ If you press **[FIND]** button without entering number, you see the whole phone number list in the memory Location and you can find the number by scrolling the list.

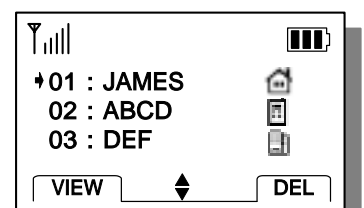

4. Pick up the handset and Send button to call to displayed number, press **[EDIT]** to edit stored information or press **[DEL]** to delete displayed information.

- Edit process

- ✓ Modify name by **Clear** button and keypad.
(MAX 17 Characters)
 - 1) Delete name by **Clear** button.
 - 2) Enter the modified name.

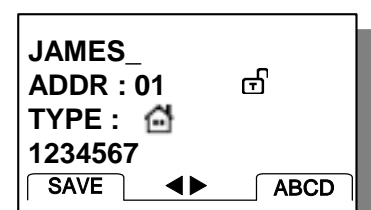

3) Press **Navigation Down Key** to go to the next step.

- ✓ Enter a new memory address to store a new information or choose the new memory address

1) Press **Navigation Down Key** to go to the next step.

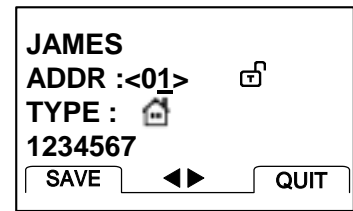

- ✓ Select secret or in secret icon secret by **Navigation Left / Right Key**

1) Press **Navigation Down Key** to go to the next step.

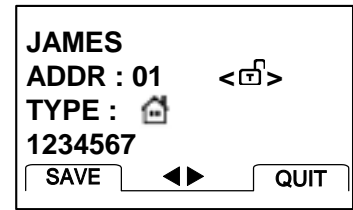

- ✓ Select the **Phone Number Type** by **Navigation Left / Right key**.

1) Press **Navigation Down Key** to go to the next step.

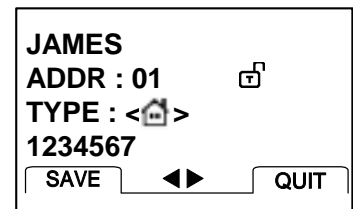

- ✓ Modify the phone number by **Clear** button (MAX 32 Digits)
 - 1) Delete the phone number by **Clear** button.
 - 2) Enter the modified phone number.

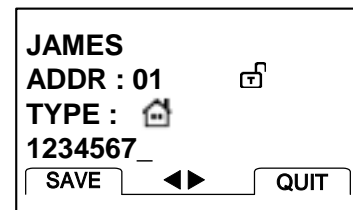

- ✓ Press **[SAVE]** to store the edited information

- Quitting process

- ✓ You might press **[QUIT]** to go to Idle State at the above step 5.

6.3 Retrieving Phone Number by NUMBER

1. Press **[BOOK]** and **2**(FROM MEMEORIES).
2. Press **3** button to retrieve a phone number by number.
3. Enter the phone number that you want to find and press **[FIND]** button.

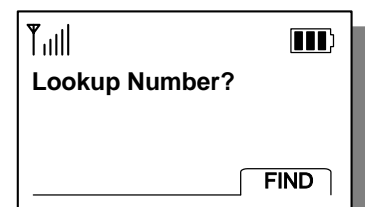

- ✓ If there is no stored phone number in the memory location, "No number matches" is displayed.
4. Pick up the handset from the charger or press Send button to call to displayed number, press **[EDIT]** to edit stored

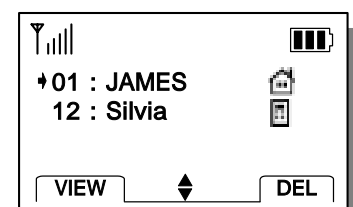

information or press **[DEL]** to delete displayed information.

- Edit process.
- Quitting process
 - ✓ Do the above step of 6.2.2.

6.4 Fast Searching

1. Press **[BOOK]** button

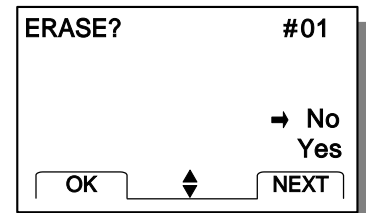

2. Press **[BOOK]** button again.

- ✓ You see the whole phone number list in the memory Location and you can find the number by scrolling the list.

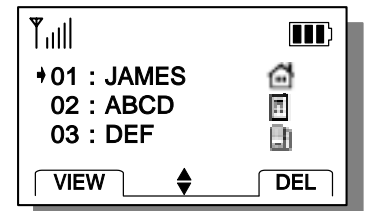
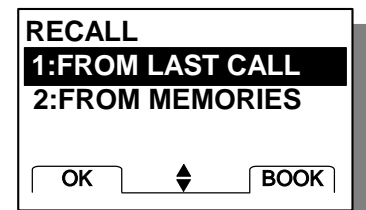

6.5 Clear Memory

When you want to delete phonebook memory, you can erase all phonebook memory.

4. Press **[MENU]** + 4(Security) + Enter Lock Code
5. Press **3**(Clear Memory).
6. Select 'Yes' using **Navigation Up /Down Key** or **[NEXT]** button
7. Press **[OK]** to erase all phone memory.

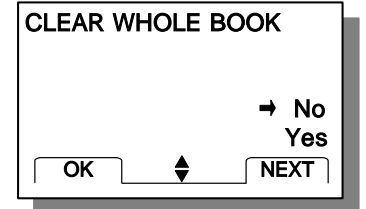

7.SMS (Short Message Service)

Messaging, Paging, and Voice mail features are available when your phone is turned on. Using **Message** button allows you to access messages for viewing on the LCD screen or to send a message.

Check with your WLL service provider regarding the availability of this feature. The information in a message depends on the mode the WLL is operating in and the service's capabilities.

7.1 Checking & Deleting Received Message

7.1.1 Text Message

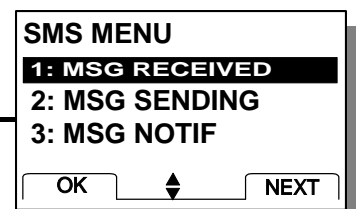

1. Press **MESSAGE** button and **1**(MSG RECEIVED)

2. Press **1**(Text MSG) to see a received text message list.

- ✓ Locate **➡** to the desired message in the list.
- ✓ Mark “(“means already a checked message.

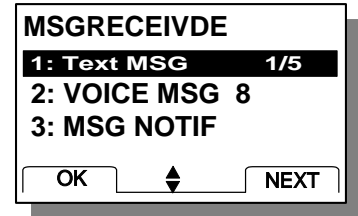

3. Press [VIEW] to see the content of desired message.

- ✓ You can see the message with received time and caller's phone number.
- ✓ You can read a l message.

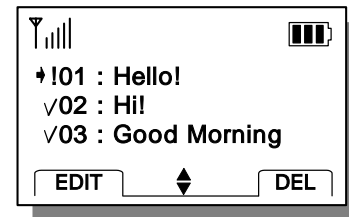

4. Press [DEL] to erase a message.

- ✓ Press [OK] to complete erasing process.

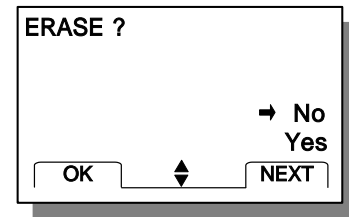

7.1.2 Voice Message

Voice mail notifications indicate the number of new voice mail message in your mail box. Only the most recent voice mail notification will be stored in the WLL phone; previous messages will be overwritten. When a voice mail messages left for you, the WLL phone will alert and display “ * Voice Mail * “. You must call your voice mail service to retrieve these messages.

1. Press **MESSAGE** button and **1**(Received MSG) in idle state.

2. Press **2**(Voice MSG) to check the voice message.

- ✓ If there is no voice message, “No Voice Mail was received” is displayed.

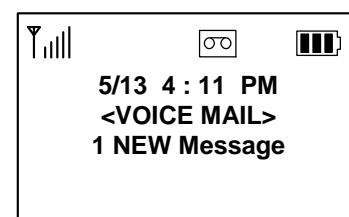

- ✓ Press **[DEL]** to delete the voice message.

7.1.3 Erasing all Received Message

1. Press **MESSAGE** button and 1(MSG RECEIVED).
2. Press 3(Clear All)
3. Press **[OK]** to delete.

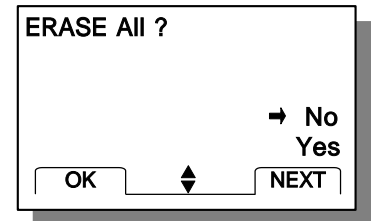

7.2 MSG Notification tone select

1. Press **Up** button and 3(MSG NOTIF).
2. Select **off, once, Every 2 Min** by pressing **[NEXT]** or **Navigation Up / Down Key**.
3. Press **[OK]** to save and exit.

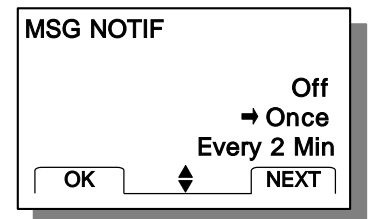

7.3 Message Sending

7.3.1 Sending a New Message

1. Press **Navigation Up** button and 2(MSG SENDING).

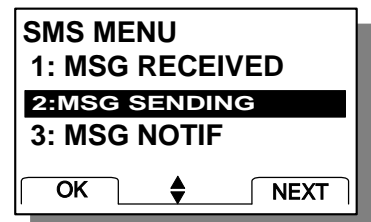

2. Press 1(New Message) to send a new message.

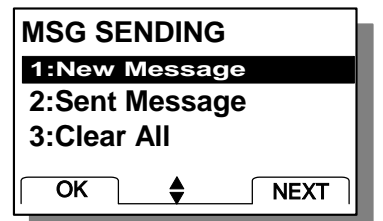

3. Enter the called number and press **[OK]**

- ✓ You can find the called number in the memory by **[FIND]** button

4. Enter the call back number and press **[OK]**

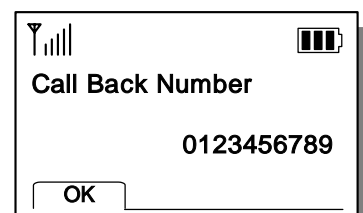

5. Input a message and press **[OK]** to send

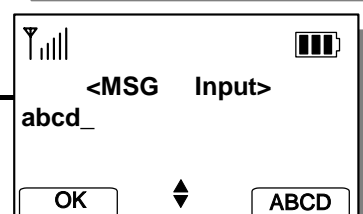

Press **[ABCD]** to change upper or lower case character

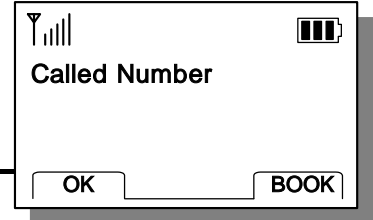

6. Select Yes/No to store the message. Press **[OK]** to send

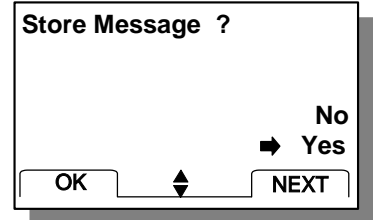

7.3.2 Sending the sent Message or message after editing the Sent Message

1. Press **Navigation Up** button and **2**(MSG SENDING).

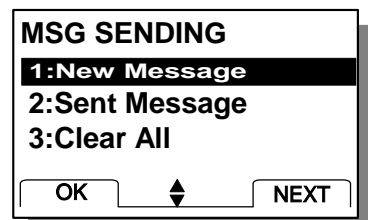

2. Press **2**(Sent Message) to see a received text message list.

✓ Locate **➡** to the desired message in the list.

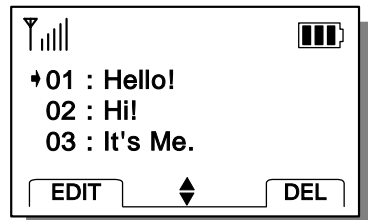

3. Press **[EDIT]** to edit the content of the selected message.

✓ You can see the selected sent message

✓ Edit the message. Press **[ABCD]** to change upper or lower case character

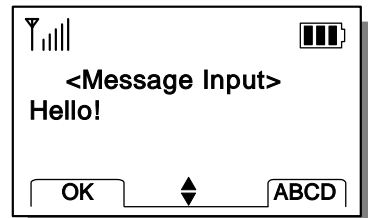

4. Press **[OK]** Button.

5. Enter the called Number and press **[OK]**

6. Enter the call back Number and press **[OK]**

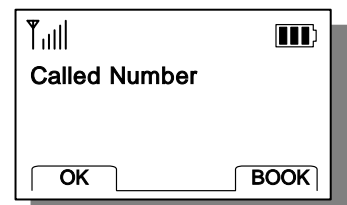

7. Select Yes/No to store Message. Press **[OK]** to send the MSG

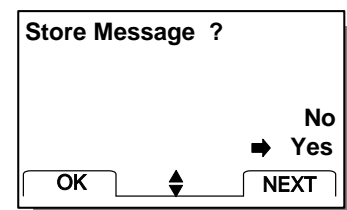

7.3.3 Erasing a Sent Message

1. Press **Navigation Up** button and **2**(MSG SENDING)

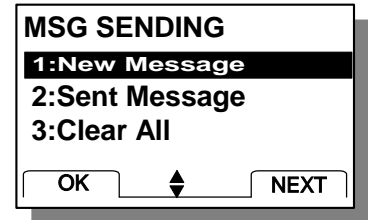

2. Press **3**(Clear All) to clear text message list.

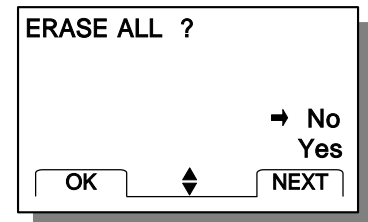

3. Press **[OK]** to erase a message.

8. Beside Functions

8.1 Redial

- ✓ Pick up the handset.
- ✓ **Send** button and **Redial** button to redial last outgoing number.

8.2 Finding Last Call History

Pick up the handset from the charger or press **Send** button and **Redial** button to redial last outgoing number.

(LSI-1100 Only)

If re-dialed number is a received number,
@ will be attached in front of re-dial number.

You can't connect a line even if you redial at above case.

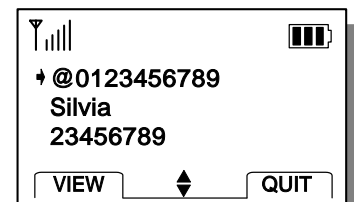

8.3 Flash

- ✓ The same as that of a single line phone.

8.4 Safe mode

Even if you misplaced the handset for long, the phone returns to the normal state.

After the ROH tone, the phone returns to the IDLE state as the picture and the phone is able to receive a call.

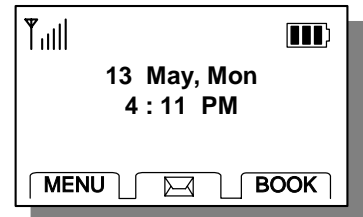

9. Storing Phone Number

9.1 Storing/Editing Phone Numbers

9.1.1 Storing Phone Numbers

Frequently used phone numbers can be stored on the memory locations (01~99: 2 digits) and you can make a call by pressing memory location number in off-hook state.

1. Enter the area code and phone number in on-hook state.
(Max. 32 digits)
2. Press **[SAVE]**.
3. Select **Phone number Type** by **Navigation Left Key**
or **Navigation Right Key**.
4. Press **[SAVE]**.

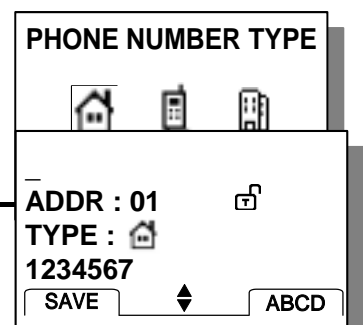
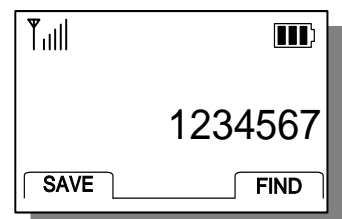

5. Enter the name in text mode and press **Navigation Down Key** to go to the next step. Press **[ABCD]** to change upper or lower case characters. (Max. 17 characters)

- ✓ To store without name, just press **Navigation Down Key**.
- ✓ Refer to “To enter a character”.

6. Enter the desired memory location and and press **Navigation Down Key** to go to the next step.

- ✓ The phone number is stored in the displayed memory location.

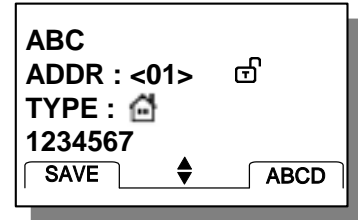

7. The phone will display an icon asking to keep your number as secret or not.

- ✓ Select “secret icon” or “in secret icon” by **Navigation Left / Right Key**.
- ✓ Press **Navigation Down Key** to go to the next step.

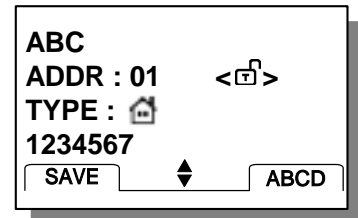

8. The phone will display an icon asking for the **Phone number type** to store your number.

- ✓ Select Phone Type by **Navigation Left / Right Key**.
- ✓ Press **Navigation Down Key** to go to the next step

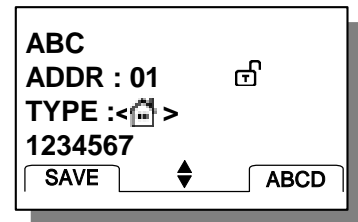

9. The cursor will be on the next location of the input number.

If you want to edit the input number,

- ✓ Modify the phone number by **Clear** button
- ✓ Enter the modified number.

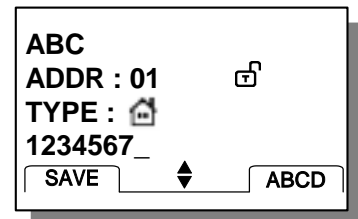

10. Press **[SAVE]** to store above the information.

- If you enter another number after you select another phone number type,

The phone will display icons asking for the representative number type.

- Press **[SAVE]** after you select the representative number type by **Navigation Left / Right Key**.
- Press **[SAVE]** at each steps if you want to store the entered information at above each steps

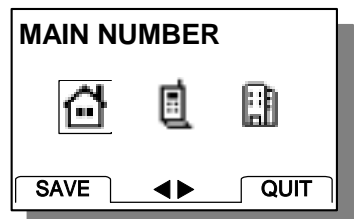

- ✓ You can see a confirming message.

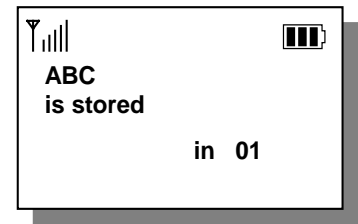

- ✓ Also you can see a condition of used memory.

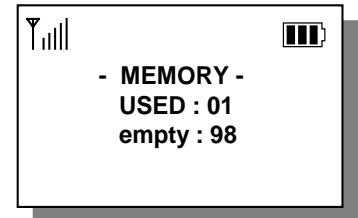

- **To enter a character.**

You can enter English character in editing mode.

You can enter English character as default, and press **Message** to select specific character.

- **To enter English character.**

Press once a keypad to enter the first letter labeled in the keypad, twice to enter the second letter and 3 times to enter the third letter.

EX) To enter "L",

Press dial button **5** labeled "JKL" 3 times to enter "L".

- ✓ After 2 seconds entering a character, the cursor is moved to the next position automatically.
- ✓ Press **Navigation** button to move the cursor.
- ✓ Press **Clear** button to erase or correct entered character.

- **To enter specific character,**

Press **Message** to view a desired character while you are entering names.

- ✓ Special characters includes *, #, %, ", :, +, <, >, =, and more
- ✓ Press the number next to the character you want insert.

9.1.2 Erasing Stored Phone Numbers

When a phone number is stored in a memory location, you can erase the stored phone number.

1. Press **[BOOK] + 1**(FROM MEMORIES) + **3**(By Number) and enter a number of the desired memory location to erase.

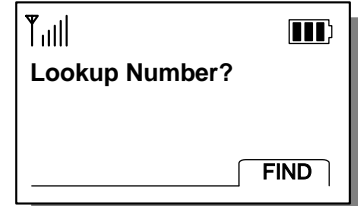

- ✓ If there is no stored phone number in the memory location, "Empty Location" is displayed.

- ✓ If you do not remember the memory location to erase, press **[FIND]** to search phone number by memory location

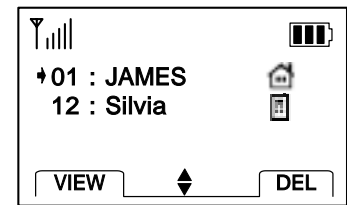

2. Erasing process

- ✓ Press **[DEL]** to delete

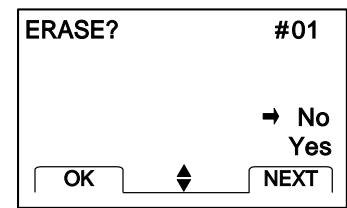

- ✓ Select 'Yes' using **Navigation Up Key/ Navigation Down Key** or **[NEXT]** button

- ✓ Press **[OK]** to complete erasing process.



9.2 Finding Stored Phone Numbers

You can see all the list of stored phone numbers in memory list and if you forgot the memory location, can find it in sequence. And You can place a call with the phone number.

1. Press **[BOOK] + 1**(FROM MEMEORIES) +**3**(By Number) in on-hook state.

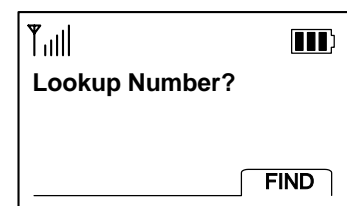

2. Press [FIND] button to find the desired phone number.
 - ✓ Locate ➔ in the desired name or address to find.
 - ✓ If not any entered name, phone number is displayed.

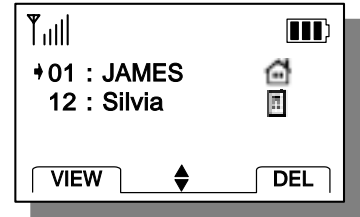

3. Press [VIEW] to see the stored number.
3. To make a call with the phone number in the state of step 2 or step 3, pick up the handset from the charger or Press Send button and wait for Auto Time-out.

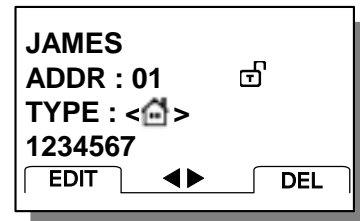

10. General Information

Main Unit

Item	LSI-1100	
Tx Frequency	Digital : 1850 ~ 1910 MHz	
Rx Frequency	Digital : 1930 ~ 1990 MHz	
Channel Bandwidth	1.25 MHz	
Tx Power	Digital : 23.0dBm	
Rx Sensitivity	-104 ~ -25dBm	
Size	45 X 161 X 35.7 (L X W X H)	
Weight(g)	About 129(with battery)	
	About 107 (without battery)	
Operating Temperature	0 ~ 50	

AC/DC Adapter

Item	SMPS Type Description
Input Voltage	AC 100 ~ 240V / 0.2A

**LGE CDMA Fixed Wireless Telephone
LSI-1100**

Input Frequency	50 / 60Hz
Output Voltage	DC12V, 0.5A

Battery

Item	Description
Capacity	3.7V LI-ion 750mAh
Talk duration time	1 Hours
Standby duration time	72 Hours
Charging duration time	Quick charge 3 Hours

Licensed by QUALCOMM Incorporated under one or more of the following Patents:

U.S, Patent No. 4,901,307 U.S, Patent No. 5,056,109 U.S, Patent No. 5,099,204
U.S, Patent No. 5,101,501 U.S, Patent No. 5,103,459 U.S, Patent No. 5,107,225