

CDMA Fixed Wireless Terminal User Guide

Model: LST-260

REVISED HISTORY

DATE	ISSUE	CONTENTS OF CHANGES	REMARK
2005.4.21	ISSUE 0.1	Preliminary	FCC DOC

Please read this manual before you use this product. This manual is based on the production version of LST-260 FWT. Software changes may have occurred after this printing. LGE reserves the right to make changes in technical and product specifications without prior notice.

Blank Page

Table of Contents

1. Before You Start	7
1.1 Safety Information.....	7
1.2 Optimal Phone Performance	7
1.3 Care and Service	8
◆ Safety Information.....	8
2. Introduction	11
2.1 Front, Side and Rear View of the Terminal.....	12
2.1.1 Installation for Wall Mounting.....	13
2.2 3 LEDs Indicators.....	14
2.3 Installation.....	14
STEP 1. Check Components.....	14
STEP 2. Place the Terminal.....	15
STEP 3. Connect Components.....	15
STEP 4. Check LED Indicators.....	15
2.4 Installation Steps.....	17
3. Basic Operation.....	18
3.1 Power On.....	18
3.2 Placing a call.....	18
3.3 Receiving a call.....	18
3.4 Ending a call	18
3.5 Warning Tone after Remote Disconnect	19
3.6 Emergency Call.....	19
3.7 Power Off.....	19
4. System Features	20
4.1 Hook flash	20
4.2 ROH (Receiver Off Hook)	20
4.3 System Features.....	20
4.4 Applications.....	21
5. Programming.....	22
5.1 Speed Dial.....	22
Storing the Speed Dial Number	22
Enable or Disable Speed Dial.....	22
Erase All Speed Dials	23
Operation	23
5.2 Emergency Call.....	23
Entering the emergency phone number	23
Enable or Disable emergency call	23
Erase All Emergency Call Numbers	23
5.3 Hot Line.....	24
Programming the Hot Line number	24
Enable the Hot Line Feature.....	24
Disable the Hot Line Feature.....	24
Programming the Hot Line Time.....	24
5.4 Alarm	24
Entering Alarm Time (12-hour Mode)	24
Entering Alarm Time (24-hour Mode)	25
Disable Alarm Feature	25
5.5 Volume Level	25
Changing the Volume Level.....	25
5.6 Outgoing Call Lock.....	25
Enable or Disable Outgoing Call Lock.....	25
Changing Outgoing LOCK Code	26
5.7 G3 FAX / DATA Mode Setting	26
Enable or Disable G3 FAX mode (Only LST-260F).....	26
Enable or Disable DATA mode	26

5.8 Restrict Call Mode Setting	27
Set Restrict Call Level	28
Storing the Permit Dial Number	28
Storing the Deny Dial Number (Restricted dial number)	28
6. Troubleshooting.....	29
7. General Information	30
7.1 LST-260	30

1. Before You Start

1.1 Safety Information

Warning

To reduce the risk of fire or electric shock, do not expose this product to rain or moisture. Do not use this product near swimming pools or other bodies of water.

IMPORTANT

Before installing or operating this product, read this information.

1.2 Optimal Phone Performance

- Do not operate your product when holding the antenna, or when someone is within four inches (ten centimeters) of the antenna.
Holding the antenna affects call quality and may cause the telephone to operate at a higher power level than needed.
- For the best call quality, keep the antenna free from obstructions and point the antenna straight up.
- Do not use the unit with a damaged antenna. Have your antenna replaced by a qualified technician immediately. Use only a manufacturer-approved antenna. Non-approved antennas, modifications, or attachments could impair the call quality or damage the phone.
- RF energy may affect improperly installed or inadequately shielded personal medical devices such as pace markers, hospital monitor. Consult the manufacturer of any personal medical devices to determine if they are adequately shielded from external RF energy. Turn your terminal OFF in health care facilities when any regulations posted in the areas instruct you to do so. Hospitals or health care facilities may be using equipment that could be sensitive to external RF energy.
- If this equipment does cause harmful interference to radio or television reception, which can be determined by turning the equipment off and on, the user is encouraged to try to correct the interference by one or more of the following measures:
 - Reorient or relocate the receiving antenna
 - Increase the separation between the radio or television and the telephone.
 - Connect the equipment into an outlet on a circuit different from that to which the terminal is connected.
 - Consult you Authorized LG Dealer or an experienced radio/TV technician for help.
- Use only the battery, antenna and AC power supply provided by LG. Using any other type will invalidate the warranty.
- Only authorized personnel should service the phone and its accessories. Faulty installation or service may be dangerous and may invalidate the warranty.
- Do not use the unit in designated "no cellular phone use" area.
Avoid exposure to high temperature or humidity

- Avoid wetting the unit with any liquids. If the unit gets wet, turn the power off immediately and remove the backup battery and AC power supply. If the unit is inoperable, then return to the service agent for service.
- Avoid shock or impact.
- We recommend you to charge the backup battery before initial use. Backup battery may be discharged during delivery.
- This device complies with part 15 of the FCC Rules.
Operation is subject to the following two conditions:
 - This device may not cause harmful interference, and
 - This device must accept any interference received, including interference that may cause undesired operation

1.3 Care and Service

- Unplug the Telephone from the wall outlet and remove antenna (or disconnect antenna cable) before cleaning. Do not use liquid or aerosol cleaners. Use a damp cloth for cleaning.
- If the unit fails for any reason, do not attempt to disassemble; contact the telephone service provider for assistance.
- If any of the following conditions exist: Unplug the unit at the wall plug, remove battery, and call the service provider.
 - The power supply cord is damaged or frayed.
 - Liquid has been spilled into the unit.
 - The unit has been exposed to rain or water.
 - The unit has been dropped or damaged.
 - The unit does not work normally by following the operating instructions.

◆ Safety Information

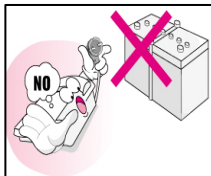

- Do not use with car battery. It may be an electric shock, fire, breakdown or transformation.
- For safety use, use only adapter approved by LG.
To all problems arising from not following this guide, LG does not bear responsibility.



- Avoid exposure to high temperature or humidity. Avoid wetting the unit with any liquids. If the unit gets wet, turn the power off immediately and remove the backup battery and AC power supply.
- Keep it dry. Precipitation, humidity, and liquids contain minerals that will corrode electronic circuits.

**LGE CDMA Fixed Wireless Terminal
LST-260**



- Do not use or store it in dusty, dirty areas as its moving parts can be damaged.

- Do not store it in hot areas. High temperatures can shorten the life of electronic devices, damage batteries, and warp or melt certain plastics.
- Do not store it in cold areas. When the phone warms up to its normal operating temperature, moisture can form inside the phone, which could damage the phone's electronic circuit boards.



- Do not attempt to open it. Non-expert handling of the device could damage it. Consult your authorized LG dealer for help. It may be a cause of fire, electric shock, and breakdown.



- Do not drop, knock or shake it. Rough handling can break internal circuit boards.



- Do not use harsh chemicals, cleaning solvents, or strong detergents to clean it. Wipe it with a soft cloth that has been slightly dampened in a mild soap-and water solution.

- Do not paint it. Paint can clog the device's moving parts and prevent proper operation.



- When lightning, do not touch power plug or phone line. It may be a cause of an electric shock or death.



- Do not install in the place where shine on the rays of the sun or on the carpet or cushion. It may be a cause of fire or breakdown.



- Before using plug, check with home power voltage. Inaccurate power voltage may be a cause of fire.

**LGE CDMA Fixed Wireless Terminal
LST-260**

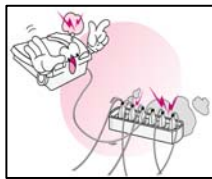

- Do not plug many power cords in outlet. It may be a cause of fire or electric shock.



- Do not remodel the power cord or disassemble. If power cord or plug is impaired, do not use it. It may be a cause of fire or electric shock.

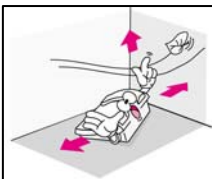

- Do not install in the ill-ventilated place. It may be a cause of fire or breakdown.



- Do not touch the plug with wet hands. When disconnect the power cord of any accessory, grasp and pull the plug, not the cord. It may be a cause of fire or electric shock.



- Do not put heavy things on the power cord. Do not bend power cord too much. It may be a cause of fire or electric shock.

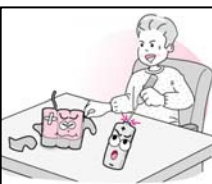

- Do not peel off battery. Do not short-circuit. You may get hurt or it may fire by generation of heat or explosion.



- Do not throw and impact battery. Do not dispose of batteries by putting them in fire. It may explode or fire by electrolyte.



- When you disconnect the power cord of any accessory, grasp and pull the plug, not the cord. It may be a cause of adapter breakdown.

2. Introduction

Congratulations on your purchase of the LG Fixed Wireless Terminal that has been designed to operate on the latest digital mobile communications technology, Code Division Multiple Access (CDMA). This CDMA digital technology has greatly enhanced voice clarity and can provide various advanced features. The terminal enables the normal operation and direct connection of standard telephone equipment into the cellular network.

The standard unit provides:

- A phone jack to plug in the telephone equipment(RJ-11 Port);
- Ring voltage used to ring the telephone connected to the unit, with a Ringer Equivalence Number of 4;
- A phone jack to plug in the G3 FAX equipment (RJ-11 Port);
- Data Port for service and repair(RJ-45 Port)
- AC Power supply with barrel plug connector;
- Support Dial tone;
- Touch tone(DTMF) or Pulse Dialing;
- Support Caller ID Telephone;
- Voice-Mail Notification ring alerts you to new voice-mail messages;
- Three lights (LEDs) to indicate the status of the unit;
- Dipole Antenna;

Some features can not be supported by service provider's equipment status.

For instance, the following features may not be supported;

- Speed Dial
- Emergency Call
- Hot Line Call
- Alarm
- Outgoing Call Lock
- Quick Dial Option with '#'

Other features as determined by your service provider.

Note: Telephones with multiple terminating impedance should be set for 600ohms.

2.1 Front, Side and Rear View of the Terminal

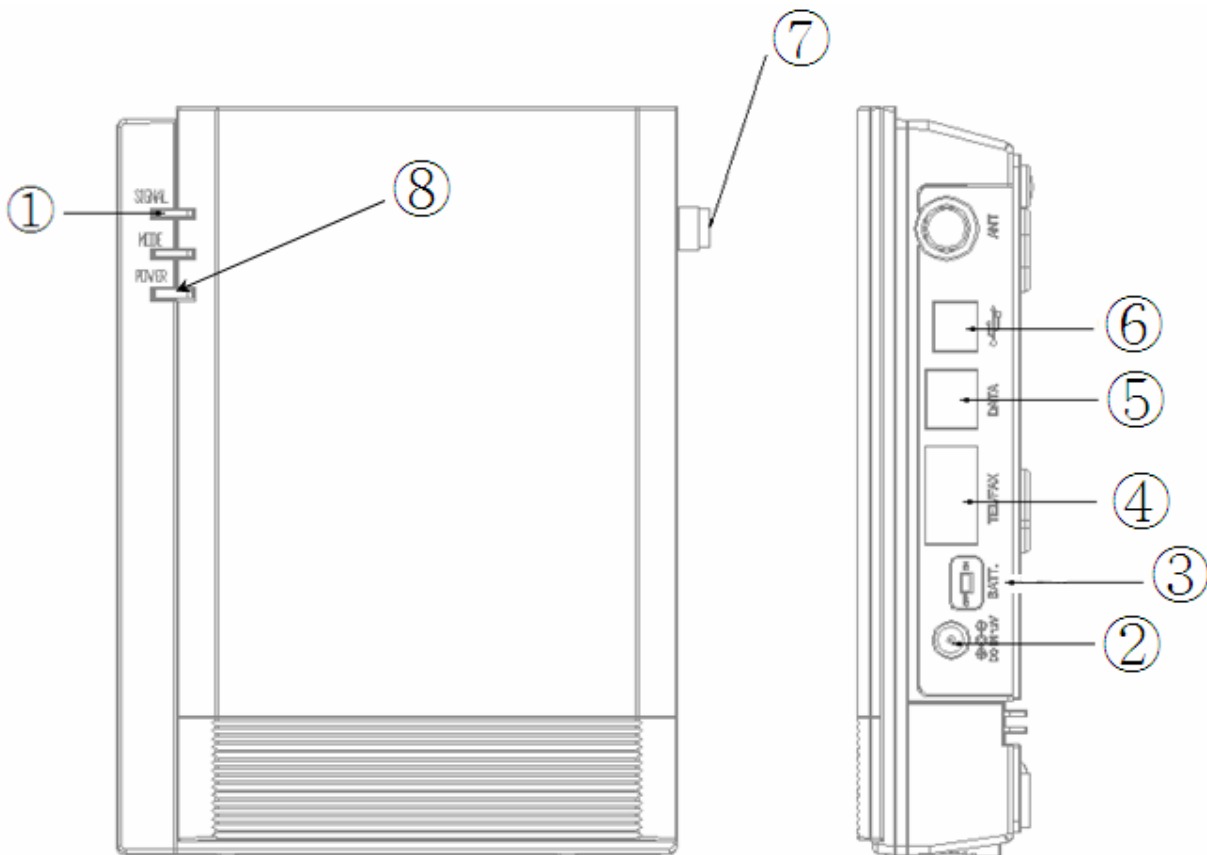

< Figure 1 >

ITEM	DESCRIPTION
① LEDs	Indicate the status of the unit
② DC IN 12V	AC/DC Power Adapter
③ Batt.	Battery On/Off Switch
④ TEL (RJ-11 Port)	Connecting Ports for SLT (Single Line Telephone)
⑤ DATA Port (RJ-45 Port)	Connecting Port for Data Service to PC(RS-232C)
⑥ USB Port	Connecting Port for Data Service to PC(USB)
⑦ Antenna Connector	Connecting Port for TNC Antenna
⑧ Power	Power On/Off Key

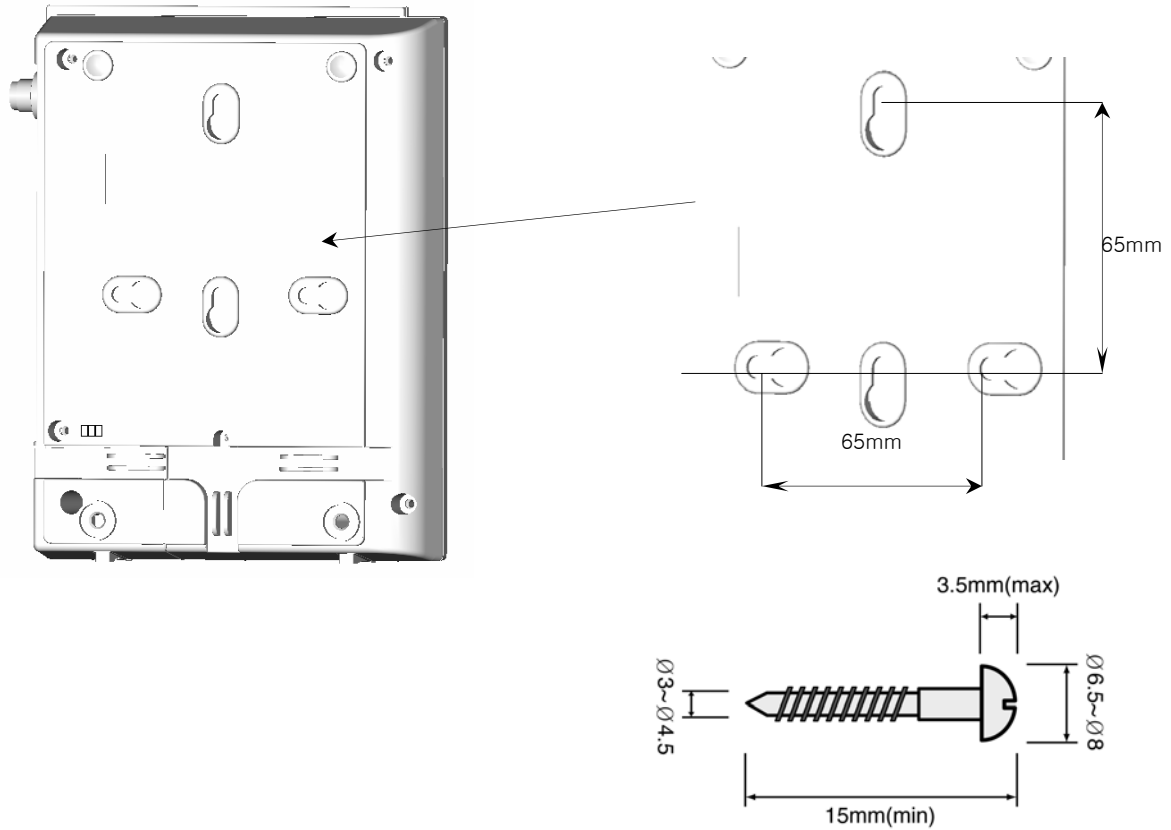

Mounting Template

2.1.1 Installation for Wall Mounting

To mount terminal on the wall, please follow the procedure to install it correctly.

1. Determine suitable location to mount terminal with mounting template;
2. Mark the two openings and select round or pan-head type screw;
3. Drill out the holes with drill bit smaller in diameter than the screws
4. Secure two screws into the wall, leaving about 65mm gap between the screw heads.
5. Insert the DC power jack into an electrical outlet and attach the telephone line into the Phone Jack (RJ-11) of the terminal.
6. Place the terminal over the two screws.
7. Slide the terminal downward until the screw head is locked at the top of the opening and the terminal is secure;
8. Check that set is fixed on the screws.

2.2 3 LEDs Indicators

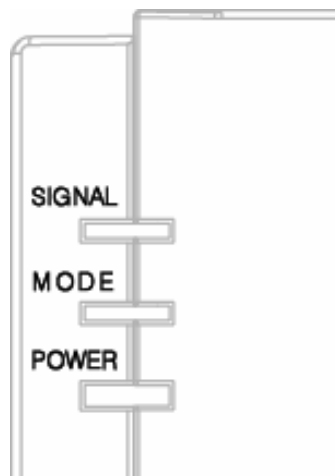

LED	COLOR	Operating Condition
POWER LED	GREEN-solid	DC Power is applied
	RED-solid	Battery Power is applied
	ORANGE -solid	Low Battery
SIGNAL LED	GREEN-solid	Good Signal
	ORANGE-solid	Poor Signal
	RED-solid	No Service Area
MODE LED	GREEN – blink (0.5sec On / 0.5sec Off)	Voice Message is received
	GREEN – blink (1 sec On / 1 sec Off)	Data Service or G3 Fax Service is working
	GREEN - solid	G3 FAX receive mode is enabled

[Table 1]

2.3 Installation

You should follow each step carefully as shown below in order to guarantee proper operation of CDMA Fixed Wireless Telephone.

STEP 1. Check Components

- Fixed Wireless Terminal is supplied with the following standard unit and accessories;
 1. LST-260 Unit - 1 EA
 2. Dipole Antenna - 1 EA
 3. Backup Battery - 1 EA
 4. User Guide - 1 EA
 5. AC/DC Power Adapter - 1 EA

- Please make sure that these components are present and check for evidence of shipping before you begin the unit installation.
- If components are missing or damage is found, contact your authorized LG distributor immediately.

STEP 2. Place the Terminal

- Place the terminal on the stable flat secure surface area (desk, table, etc.). Avoid direct exposure to the sun lights and damp area.
- Read the **Safety Information** located at the first part of this document before you place the terminal.

STEP 3. Connect Components

- Connect the Dipole antenna to the TNC connector located at the topside of the terminal. (See Figure 1 to locate the TNC connector.)
If you placed the terminal on the flat surface, bend the antenna up side.
- Connect your phone cord to the RJ-11 port located at the side of the terminal.
- Connect the battery cable to the DC battery connector at the side of the terminal.
 - . Remove the battery compartment cover.
 - . Connect battery to the connector.
 - . Replace the battery cover.
- Connect the AC power supply cable to the DC input port located at the side of the terminal.
- If you use Data Service or PC FAX Service, connect your RS-232C cable cord to the RJ-45 port or USB Cable cord to the USB port located at the side of the terminal.
- If you use G3 FAX machine, connect your line cord of G3 FAX to the RJ-11 port located at the side of the terminal. (only LST-260F)

“Refer to connection Diagram with external equipment in Figure 2 ”

STEP 4. Check LED Indicators

- When you followed the installation instruction STEP 1 to STEP 3, please check the LEDs for normal operation.
- When DC power is fed at the first time, LEDs will operate as follows:
After few seconds, Power LED is GREEN, if AC/DC power is applied.
If receiving signal strength is strong enough, then SIGNAL LED is GREEN.
If not, it is ORANGE or RED. And MODE LED is turned off.

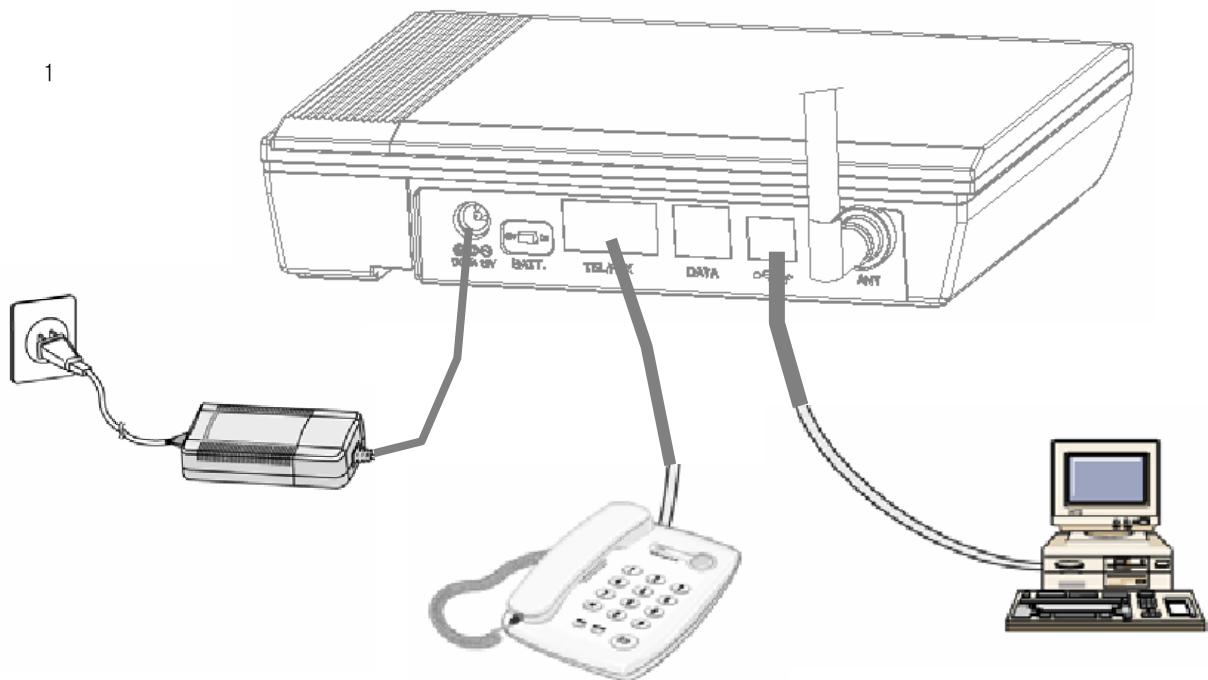

[LST-260]

[Figure 2. Connection Diagram with External Equipment]

*** Note :**

- G3 FAX can not connected to your LST-260 terminal.
- Length between LST-260 and Telephone : over 1m.

The adapter type(with power cord) may be different from country to country.

! Connection telephone jack to data port will cause malfunction of data service



[Battery Switch]



Notice

**Before using the terminal, please check battery switch is on.
After switching on it, use the phone. When charging the battery,
check that battery switch is "on".
Battery is charged only when battery switch is on.**

2.4 Installation Steps

Please follow the below procedure to install the unit properly.

1.

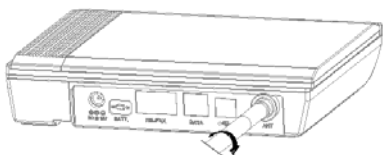

Connect the Antenna to the TNC connector (Turn right).

2.

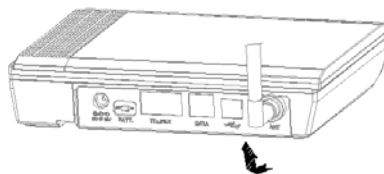

Bend the antenna up right.

3.

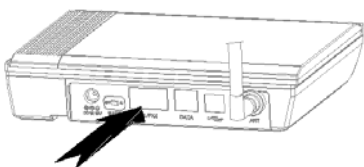

Connect your Phone Cord.

4.

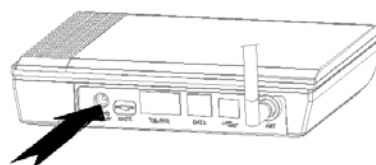

Connect the Power supply

Terminal Connection

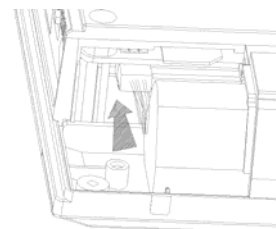
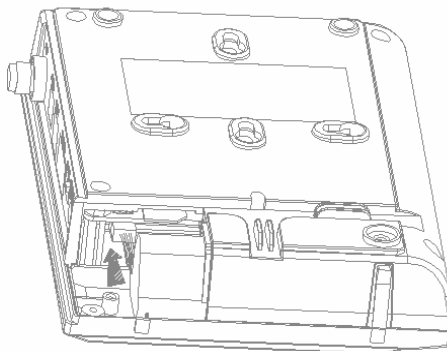
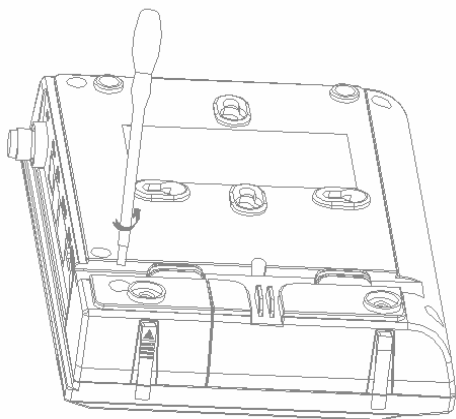

Battery Connection

- First, slow down the terminal slide switch and unscrew.
- To connect battery, disassemble terminal like above figure.
- Battery connector's groove must be slid into the jack like above figure.

3. Basic Operation

3.1 Power On

1. The POWER LED indicates the presents status;
 - 1) Using AC Adapter : Solid GREEN
 - 2) Using internal battery : Solid RED
 - 3) Using internal battery and battery is weak capacity: Solid ORANGE
2. When the terminal succeeded in getting the service, SIGNAL LED indicates the strength of the signal(Table 1).

Lifting handset on telephone, dial tone is heard and you can enter a phone number.

Note :

- *) Not entering any key for 15 seconds warning tone will be produced.
 - *) In the overlap dial mode, it may take over 15seconds.
 - *) If Hot Line function is enabled, busy tone is not produced and hot line number is automatically connected.
 - *) While having maintenance request order or lock order from the system, neither dial tone nor busy tone is produced. Instead of them, the lock tone("pi-pi-pi") will be heard one time and there will be no sound and ALL LED's will be blinking with GREEN color simultaneously
3. If the radio service is not available or radio signal is too weak to detect;
The SIGNAL LED is RED. (No Service status)

3.2 Placing a call

When lifting handset of the connected telephone ("off hook"), the terminal determines whether cellular service is available.

If it is available, dial tone is produced and a number can be dialed normally.

If phone service is not available, SIGNAL LED of the terminal will be RED and no dial tone will be heard.

If user press '#' button after dialed the number, the terminal make a call immediately.

3.3 Receiving a call

The connected telephone rings when an incoming call is detected.

Pick up the handset and begin talking.

3.4 Ending a call

When you have completed the call, place the handset back on telephone. Also you can hook

flash more than about 1 second to end a call and place a new call without hanging up the handset.

3.5 Warning Tone after Remote Disconnect

A warning tone may be heard in the telephone after a remote party hangs up from a call, allowing another call to be initiated after hook-flash.

3.6 Emergency Call

When emergency call number is connected once, it will not be terminated unless the called party disconnects the call (Emergency Call Hold Service).

Therefore even caller hangs up the telephone, the line will be still connected, so if the caller picks up the telephone again, he can continue talking.

If emergency call is connected, cellular service is not supported.

As long as your telephone is registered on a system, you can place a call to emergency number even if your telephone is locked* or restricted*.

Please check the available emergency call number with your service provider.

3.7 Power Off

When you need not to use terminal anymore, you should do power off before removing AC/DC adapter cable.

If you do terminal power off, Press Power key for 3 seconds. If so, the terminal will led off and will stop all operation. Then you shall separate External Power jack from Terminal.

4. System Features

4.1 Hook flash

When the terminal receives a hook-flash from the connected telephone device, it will automatically allow:

1. For producing dial tone again after a phone number has been dialed without connection.
2. The use of special cellular services which may be available in your cellular service area.

Note: Hook-flash is accomplished in a call through either pressing the dedicated hook-flash key which is available on some phones or through a rapid single press of the hang-up mechanism upon which the handset rests when the phone is hung up.

4.2 ROH (Receiver Off Hook)

If the telephone equipment remains “off-hook”, meaning that the handset is left off of its cradle as it would be when you hang up, with no dialing activity for about 60 seconds, a ROH tone emits from the receiver for a period of 60 seconds. After ROH tone, Line Lock Out Tone emits from receiver for a period of 60 seconds.

This feature may be different or not by country specification.

4.3 System Features

Many cellular system offer special services such as call waiting, call forwarding, etc. You can purchase these services from your cellular service provider. There are certain dialing sequences to be earned, which vary from service provider to service provider. The service provider will provide the dialing instructions for your system.

Call Forwarding - An incoming call can be delivered to another telephone number programmed. Please contact your cellular service provider to use this feature.

Call Waiting – You can receive another incoming call during a call.

In this case, you will hear beep tone and then you can connect the second call holding the first call by entering a code required by cellular service provider.

Your cellular service provider may require hook-flash (a quick, simulated “hang up”) to answer the waiting call. Other providers may require entering the codes involving digits 1-9, *, and # to answer a waiting call.

Three-way Conference Calls – For three-way conference calls, a hook-flash transmits the SEND command.

Please contact your cellular service provider for more information on using this service.

 Example

- ① Dial the first number and wait until connected;
- ② When connected, give hook-flash and dial the second number and give one more hook-flash to be connected;
- ③ When the second call is connected, give hook flash to complete a 3-way conference call.

Voice mail – Use voice mail service in the same manner as you would on a regular telephone. If you have a new voice-mail message, the WLL-terminal transmits a special Voice-mail Notification Ring (4sec On / 1sec Off default) and Mode LED is blinking (0.5sec On / 0.5sec Off). Please contact your cellular service provider for more information on using Voice Mail or to change Voice-Mail Ring pattern.

Caller ID – LST-260 can support caller ID service if you have a telephone with Caller ID feature.
*During a call, CID is not displayed.
Please contact your cellular service provider for more information on using this service.

4.4 Applications

Data Communication – LST-260 is capable of transmitting and receiving IS-707A FAX or modem communications.

For data communications, you will need a standard RS-232C cable or a standard USB cable to connect your PC and FWT terminal. For further information, please contact our authorized service dealer.

Multi-extension Installations – For a multi-extension installation, make sure that all the extensions are on-hook.

If one extension is off-hook (not hung up), none of the extensions on that line will ring when a call is being received.

5. Programming

LST-260 provides various convenient and various features to user. This chapter describes how to program these features and to use them. The followings are main features can be used;

Speed Dial
Emergency Call
Hot Line Call
Wake-up Alarm
Conversation Voice Level
Outgoing Call Lock
G3 Fax/Data Mode
Restrict Call

■ Programming Instruction

1. Lift Handset and press “#” key twice and you will hear the Menu Entering tone.
2. Enter the field number (1 ~ 9).
3. Press “#” key and you will hear confirmation tone.
4. Enter sub-fields and their options.
5. Press “*” key to save and you will hear confirmation tone.

Note :

As to the characteristic quality of some telephones, confirm tone or error tone could not be heard.

5.1 Speed Dial

LST-260 has 30 memory locations (1~30:1 or 2 digits) to store frequently used phone numbers and you can make a call by pressing memory location number only when the speed dial feature is enabled.

Storing the Speed Dial Number

1. Press “#” + “#” + “1” continuously to enter speed dial programming mode.
2. Press “#” and one of memory numbers (1~30).
3. Press “#” and the phone number (Max. 32 digits).
4. Press “*” to store.

Enable or Disable Speed Dial

1. Press “#” + “#” + “1” continuously to enter speed dial programming mode.
2. Press “#” and “1” or “2” to enable or disable respectively.
“1” – Speed Dial Enable
“2” – Speed Dial Disable
3. Press “*” to store.

Erase All Speed Dials.

1. Press “#” + “#” + “1” continuously to enter speed dial programming mode.
2. Press “#” and “3” to erase all speed dials.
3. Press “*” to store

Note 1. Speed dial feature is disabled after erase operation executed.

Operation

1. Make a speed dial function enable.
2. Lift handset and dial tone will be heard.
3. Press speed dial number and wait for dial timeout.

If user press “#” button after dialed the number, the terminal make a call immediately.

5.2 Emergency Call

LST-260 has 3 emergency call numbers (1~3) and max. 32 digits can be stored in each emergency call number.

Entering the emergency phone number

1. Press “#” + “#” + “2” continuously to enter emergency call programming mode.
2. Press “#” and one of the emergency memory location numbers (1~3).
3. Press “#” and the phone number (Max. 32 digits).
4. Press “*” to save and enable this function.

Enable or Disable emergency call

1. Press “#” + “#” + “2” continuously to enter emergency call programming mode.
2. Press “#” and Enable code (“1”) or Disable code (“2”).
3. Press “*” to save.

Erase All Emergency Call Numbers

1. Press “#” + “#” + “2” continuously to enter emergency call programming mode.
2. Press “#” and “3” to erase all emergency call numbers.
3. Press “*” to store.

Note 1. Emergency call feature is disabled after erase operation executed.

Note :

If Emergency Call is disabled and Emergency Call number has been already programmed, you can make enable Emergency Call by pressing “#” + “#” + “2” + “#” + “1” + “*” without entering a emergency call number again.

5.3 Hot Line

While the Hot line function is enabled, the programmed number will be automatically dialed when you pick up the handset and wait for the programmed hot line time (2~10sec) without any key press.

Programming the Hot Line number

1. Press “#” + “#” + “3” continuously to enter Hot Line programming mode.
2. Press “#” and Hot Line Enable code “1”.
3. Press “#” and Hot Line phone number (Max. 32 digits).
4. Press “*” to save and enable this function.

Enable the Hot Line Feature

1. Press “#” + “#” + “3” continuously to enter Hot Line programming mode.
2. Press “#” and Hot Line Enable code “1”.
3. Press “*” to save.

Disable the Hot Line Feature

1. Press “#” + “#” + “3” continuously to enter Hot Line programming mode.
2. Press “#” and Hot Line Disable code “2”.
3. Press “*” to save.

Programming the Hot Line Time

1. Press “#” + “#” + “3” continuously to enter Hot Line programming mode.
2. Press “#” and Hot Line time code “3”.
3. Press “#” and enter desired Hot Line time (2~10 seconds).
4. Press “*” to save.

Note :

If Hot Line is disabled and Hot Line number has been already programmed, you can make enable Hot Line feature by pressing “#” + “#” + “3” + “#” + “1” + “*” without entering a Hot Line Number again.

5.4 Alarm

If alarm feature is enabled, you will hear ring at the programmed alarm time every day for 1 minute.

Alarm does not ring on the state of hook off, conversation or no service.

Entering Alarm Time (12-hour Mode)

1. Press “#” + “#” + “4” continuously to enter alarm time programming mode.
2. Press “#” and alarm time code “1” for 12-hour mode.
3. Press “#” and alarm time (HHMM +am(“1”) / pm(“2”)).
4. In the forenoon, time range is 0000~1159.
5. In the afternoon, time range is 1200~1259 or 0100 ~1159.
6. Press “*” to save and enable Alarm Time.

Entering Alarm Time (24-hour Mode)

1. Press “#” + “#” + “4” continuously to enter alarm time programming mode.
2. Press “#” and alarm time code “2” for 24-hour mode.
3. Press “#” and alarm time (HHMM). (0000~2359)
4. Press “*” to save and enable Alarm Time.

Disable Alarm Feature

1. Press “#” + “#” + “4” continuously to enter alarm time programming mode.
2. Press “#” and alarm disable code “2”.
3. Press “*” to save.

Note :

If Alarm is disabled and time has been already programmed, you can make enable Alarm feature by pressing “#” + “#” + “4” + “#” + “1” + “*” without entering alarm time again.

5.5 Volume Level

There are three voice volume levels to be controlled by software, and you can set the level to the adequate conversation volume.

Changing the Volume Level

1. Press “#” + “#” + “5” continuously to enter Volume Level programming mode.
2. Press “#” and Volume Level (1~3).
 - “1” – LOW Level
 - “2” – MIDDLE Level
 - “3” – HIGH Level
3. Press “*” to save.

Before pressing “*”, you can enter volume level continuously.

5.6 Outgoing Call Lock

If you try to make an outgoing call while outgoing call lock is enabled, then you will hear warning tone after dial time-out as an indication of entering the LOCK code. You should enter LOCK code to make an outgoing call. LOCK code is composed of 4 digits. Outgoing Call Lock feature is disabled as a factory setting.

Enable or Disable Outgoing Call Lock

1. Press “#” + “#” + “6”+ continuously to enter Outgoing Call Lock programming mode
2. Press “#” and “LOCK code (4 digits)”
3. Press “#” and Enable (“1”) or Disable (“2”) code.
4. Press “*” to save.

Changing Outgoing LOCK Code

1. Press “#” + “#” + “6” + continuously to enter Outgoing Call Lock programming mode
2. Press “#” and “LOCK code (4 digits)”
3. Press “#” and “3” to change LOCK code.
4. Press “#” and “new LOCK code (4 digits)”.
5. Press “#” and re-enter “new LOCK code (4 digits)”.
6. Press “*” to save.

Note :

If emergency call has been enabled, then emergency call numbers stored can be made even when Outgoing Call Lock has been activated on the terminal.

5.7 G3 FAX / DATA Mode Setting

To activate a Data Fax call by G3 FAX connected to your LST-260 terminal from the other devices (Land or Mobile Data Fax), your service provider should support wireless data FAX. And the LST-260 mode should be changed to G3 FAX mode to change data path from RS-232C to G3 FAX machine. Because the terminal doesn't recognize the call is for FAX or voice before being response. Following is the procedure to change data path and default data path is RS-232C data path.

Once G3 Fax mode is set, if AC power is gone and turned on again, the saved G3 Fax mode value is restored.

Enable or Disable G3 FAX mode (Only LST-260F)

1. Press “#” + “#” + “7” continuously to enter G3 FAX/DATA programming mode.
2. Press “#” and Enable (“1”) or Disable (“2”) code.

Enable means that Data call path is changed to G3 FAX.

Disable means that Data call path is changed to RS-232C. (Default mode)

3. Press “*” to save.

Enable or Disable DATA mode

1. Press “#” + “#” + “7” continuously to enter G3 FAX/DATA programming mode
2. Press “#” and Enable (“3”) or Disable (“4”) code.

Enable means that Data mode is changed to USB mode.

Disable means that Data mode is changed to RS-232C mode. (Default mode)

3. Press “*” to save.

Note 1. How to setup G3 FAX mode more easily

1. Press “#” + “#” + “7” continuously to enter G3 FAX/DATA programming mode.
2. Press Enable (“1”) or Disable (“2”) code.

Enable means that Data call path is changed to G3 FAX.

Disable means that Data call path is changed to RS-232C. (Default mode)

Note 2. Sending or receiving some documents by G3 FAX is possible only in AC power mode. If AC power is gone, you cannot use the G3 Fax machine connected to the LST-260

Note 3. The recommended usage for this G3 FAX Mode is like this;

1. Disable G3 FAX Mode for normal usage.
 - You can make a voice call using the telephone device connected to the “TEL/FAX” ports of the LST-260.
 - You can FAX a document using the G3 FAX machine connected to the “TEL/FAX” ports of the LST-260.
2. To receive or send a document by FAX, should be set G3 FAX Mode. After receiving the FAX document, disable G3 FAX Mode for another voice call.
3. If you want to use the LST-260 terminal only for G3 FAX sending or receiving other than the voice call, then keep the terminal in G3 FAX Mode enabled state

Note 4. If G3 FAX mode is enabled, You cannot set Data mode(USB) and then you should disable G3 FAX mode.
If Data mode(USB) is enabled, You also cannot set G3 FAX mode and then you should disable Data mode.

5.8 Restrict Call Mode Setting

While the Restrict Call function is enabled, the specified numbers cannot be called. These specified numbers start with specific digits. The specific digits are set according to the following procedure (Storing the Deny dial number).

Among these specified numbers you can permit some numbers by designating start digits by following procedure (Storing the Permit dial number).

LST-260 has 10 Deny dial numbers (1~10), and max. 32 digits can be stored in each Deny dial number.

LST-260 has 10 Permit dial number (1~10), and max. 32 digits can be stored in each Permit dial number.

If you set Emergency call, the emergency number is not applied to this restrict call.

Note : LOCK code will always be the last 4 digits of the phone number.

Set Restrict Call Level

1. Press “#” + “#” + “8” + continuously to enter Restrict Call programming mode.
2. Press “#” and “LOCK code” (4 digits : set in Outgoing call lock).
3. Press “#” and restrict level (1~4)
“1” – No restriction
“2” – restriction
“3” – Emergency only (All excepting emergency are restricted.)
“4” – Clear restrict table
4. Press “*” to save

Storing the Permit Dial Number

1. Press “#” + “#” + “8” + continuously to enter Restrict Call programming mode.
2. Press “#” and “LOCK code” (4 digits : set in Outgoing call lock).
3. Press “#” and “1” to enter Permit Dial Number store step.
4. Press “#” and one of “Memory number” for permit dial number(1~10).
5. Press “#” and the “digits” (Max. 32digits).
6. If you want to store more Permit Dial Numbers continue from step 3
If you want to finish at this point, Press “*” to save.

Storing the Deny Dial Number (Restricted dial number)

1. Press “#” + “#” + “8” + continuously to enter Restrict Call programming mode.
2. Press “#” and “LOCK code” (4 digits : set in Outgoing call lock).
3. Press “#” and “2” to enter Deny Dial Number store step.
4. Press “#” and one of “Memory number” for deny dial number(1~10).
5. Press “#” and the “digits” (Max. 32digits).
6. If you want to store more Deny Dial Numbers continue from step3
If you want to finish at this point, Press “*” to save.

6. Troubleshooting

In the event you are unable to place or receive telephone calls, first check the appropriate power indication on the LED. In case of no power, check the wiring connections between the power outlet and the terminal. Check for the appropriate service indication on the LED. If an adequate signal is not present, try different locations for the better signal reception.

This will verify the condition of the telephone equipment and the internal wiring of the telephone service to verify that it is working properly. If the telephone system of wiring is not working properly, replace or repair the equipment as required. The unit will not function with equipment that requires data transmission.

Contact your service provider if either of the following condition is true:

- The terminal does not work and the LED indicates “No Service” and if changing the locations does not resolve the problem.
- The terminal does not work and the LED indicates “In Service”.
- Power Supply – If the unit does not respond once plugged into a power supply;
 - Check that the AC power source.
 - Check that the Barrel Plug of the Power Supply is properly inserted into the terminal.
 - Check that the terminal Power Supply is properly plugged into the electrical outlet or power source.

Warning!

1. Only Authorized Service Personnel should remove the cover of the fixed wireless terminal for additional service. The contents of the terminal contain components that present an Electric Shock Hazard if handled improperly.

2. According to the power condition, you can hear a little noise during connection.

For further assistance, contact your Authorized LG Distributor for service and assistance. Please keep your Model number and Serial number ready for quicker service.

7. General Information

7.1 LST-260

- Main Unit

Item		Description
Tx Frequency		824 ~ 849 MHz
Rx Frequency		869 ~ 894 MHz
Channel Bandwidth		1.25 MHz
Frequency Stability		± 300 Hz
Tx Power		Max. 0.28W
Rx Power Level		-104 ~ -25 dBm
Size		187 x 140 x 43 mm
Weight(g)	w/ FAX	482g (w/o battery) / 646g (w/ battery)
	w/o FAX	422g (w/o battery) / 586g (w/ battery)

- AC/DC Adapter

Item	Description
Input Voltage	100V ~ 250V AC
Input Frequency	50 / 60 Hz
Output Voltage	12V(DC)

- Internal Back-up Battery(A)

Item	Description
Capacity	7.2V NiMH
Talk duration time	4 Hours
Standby duration time	40 Hours
Charging duration time	Normal/Trickle, 10 Hours

Appendix FCC RF Exposure Information

WARNING!

The antenna used for this transmitter must not exceed 3.0dBi and must be installed to provide a minimum separation distance of 20 cm from all persons.

CAUTION

Use only the supplied and approved antenna. Use of unauthorized antennas or modifications could impair call quality, damage the phone, void your warranty and/or result in violation of FCC regulations.

Do not use the phone with a damaged antenna. If a damaged antenna comes into contact with skin, a minor burn may result. Contact your local dealer for a replacement of antenna.

FCC Part 15 Class B Compliance

This device and its accessories comply with part 15 of FCC rules.

Operation is subject to the following two conditions:

(1) This device and its accessories may not cause harmful interference, and (2) this device and its accessories must accept any interference received, including interference that may cause undesired operation.

Licensed by QUALCOMM Incorporated under one or more of the following Patents:

U.S, Patent No. 4,901,307 U.S, Patent No. 5,056,109 U.S, Patent No. 5,099,204

U.S, Patent No. 5,101,501 U.S, Patent No. 5,103,459 U.S, Patent No. 5,107,225