

JLR TCU3 Overview for FCC

Jan. 6. 2016

LG Electronics Inc.



Contents

1. Introduction of TCU
2. Modularization of NAD
3. Hardware block diagram
4. JLR TCU3 Specification
5. Test environment
6. Appendix

❑ TCU (Telematics Control Unit)

- Telematics device that LGE is developing for the JLR(Jaguar Land Rover) vehicles.
- Small box installed deep inside passenger cars
- In charge of wireless communications in LTE/WCDMA/GSM network

❑ Services provided by TCU

- Voice service : eCall, bCall¹⁾ and ERA GLONASS
- Packet data service : Wi-Fi hot-spot and TSP²⁾ service
- SMS service : TSP service

1) bCall : breakdown call
2) TSP: Telematics Service Provider (Wireless Car for JLR)

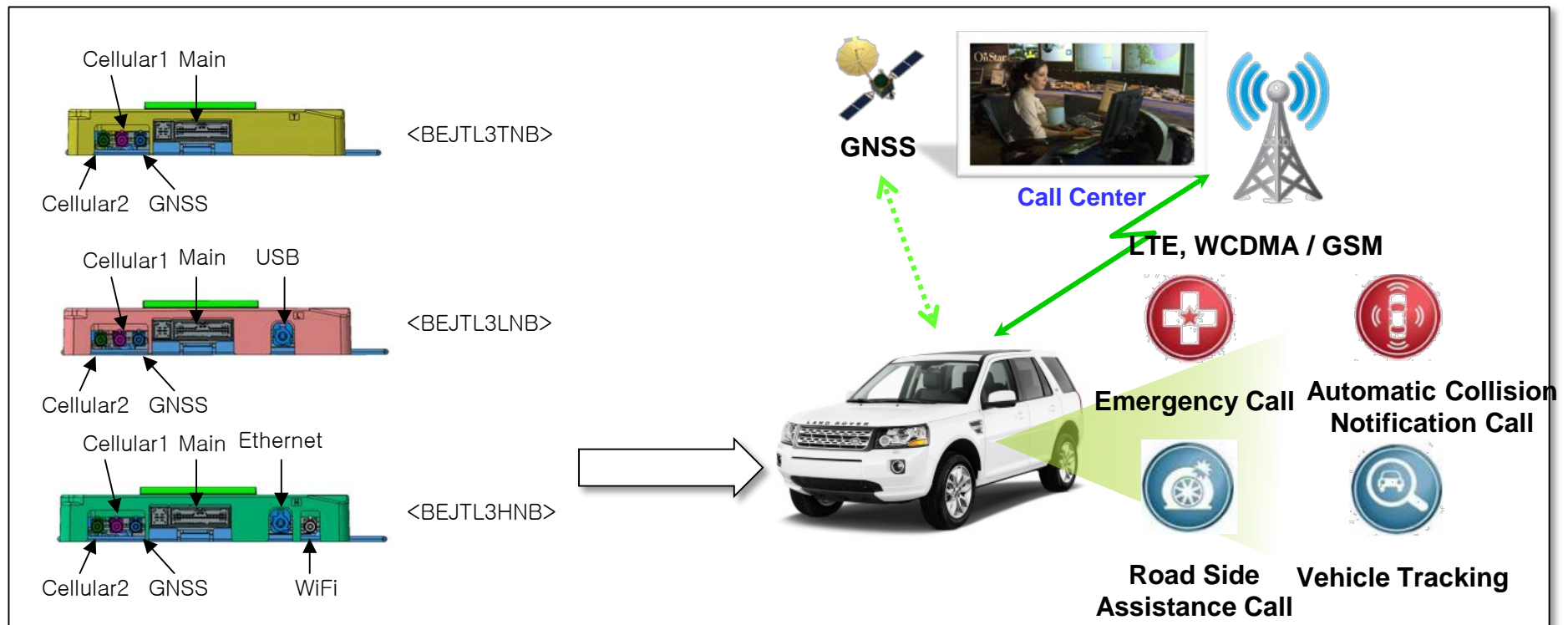

□ NAD Module

□ Integrated device (BEJTL3HNB)

< H/W Design >

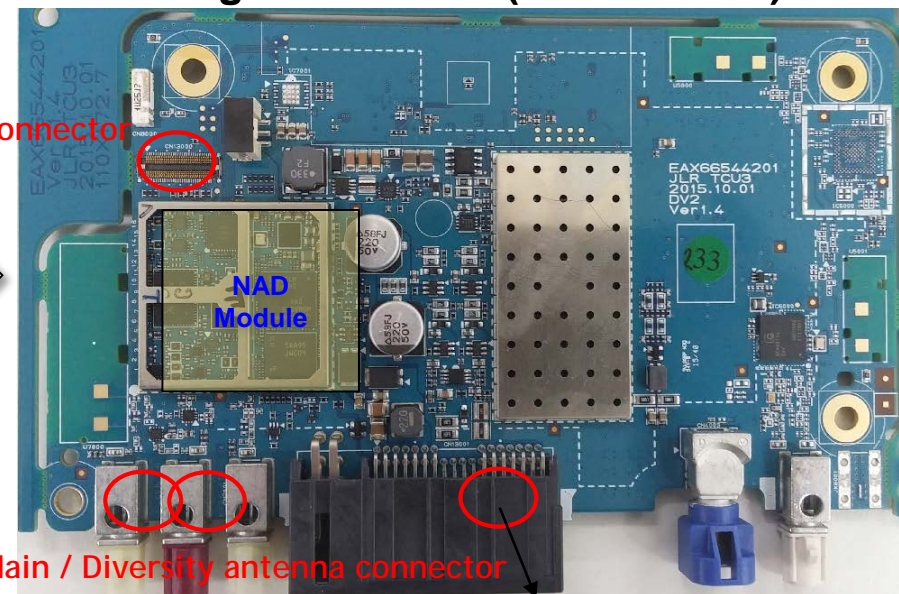
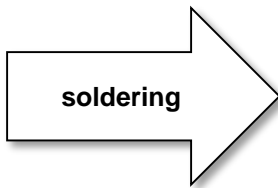
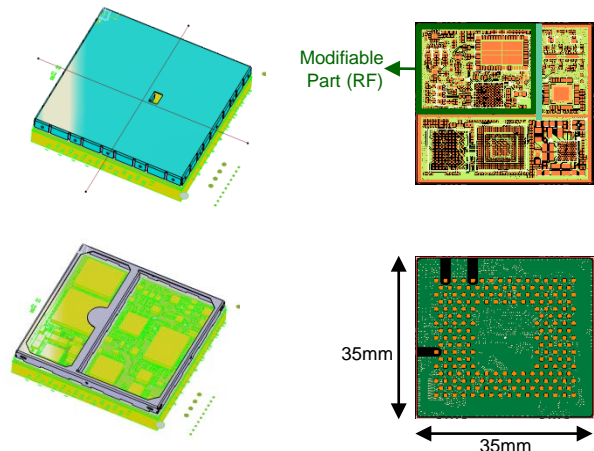

Item	Description
Dimension	35mm x 35mm x 3mm
Package	LGA, 206 pin
Baseband Chip	MDM9215 (Qualcomm)
Power Management Chip	PM8018 (Qualcomm)
RF Chip	WTR1605L (Qualcomm)
GNSS	GPS + GLONASS
Application Processor	Cortex-A5 (550MHz)
Memory	4Gbit NAND + 2Gbit LPDDR
Audio DSP	AK7758 (CS Voice, VoLTE)
Radio Technology	GSM/GPRS/EDGE UMTS/HSPA+ FDD/TDD-LTE (Release9 Cat3)

USB connector for debugging

Item	Description
Network carriers	AT&T (Vodafone roaming)
Positioning	Yes
Emergency	Private eCall, (the support of E911 is TBD)
VoLTE	Yes (but, do not have specific use case)
RF band	LTE – B2,4,5,7,12,17 WCDMA – B2,4,5 GSM – 850, 1900
Sourcing countries	NA, EU, CN, ROW (total 86 countries) Refer to appendix

3. Hardware Block Diagram

- ❑ NAD module is based on MDM9215 and it includes modem baseband, RF and GNSS
- ❑ NAD module is used as common platform for three type of variants
- ❑ Certification is focused on NAD module

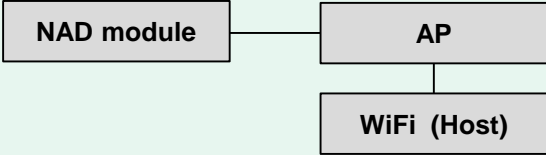
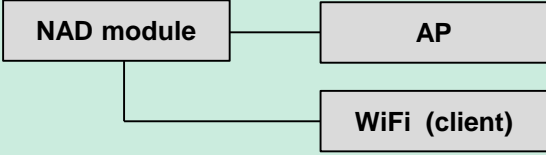
Devices	Difference
BEJTL3TNB	NAD module only 
BEJTL3LNB	NAD module + External AP with WiFi host 
BEJTL3HNB	NAD module + External AP + WiFi Client 

4. JLR TCU3 Specification

DUT	BEJTL3TNB	BEJTL3LNB	BEJTL3HNB
RF variants	GSM850 and 1900 WCDMA B2, B4, and B5 LTE B2, B4, B5, B7, B12 and B17	GSM850 and 1900 WCDMA B2, B4, and B5 LTE B2, B4, B5, B7, B12 and B17	GSM850 and 1900 WCDMA B2, B4, and B5 LTE B2, B4, B5, B7, B12 and B17
External AP	X	O	O
Ethernet (BCBR)	X	X	O
WiFi Host	X	O	X
WiFi Client	X	X	O
USB (Remote SIM)	X	O	X
Bluetooth Smart Node	O	O	O
CAN	HSCAN1, 2	HSCAN1, 2	HSCAN1, 2
Audio (Mic. Input, Spk Output)	O	O	O
BUB	O	O	O

5. Test Environment

- ❑ This is picture of telematics box inside. Refer to connector information in page 2

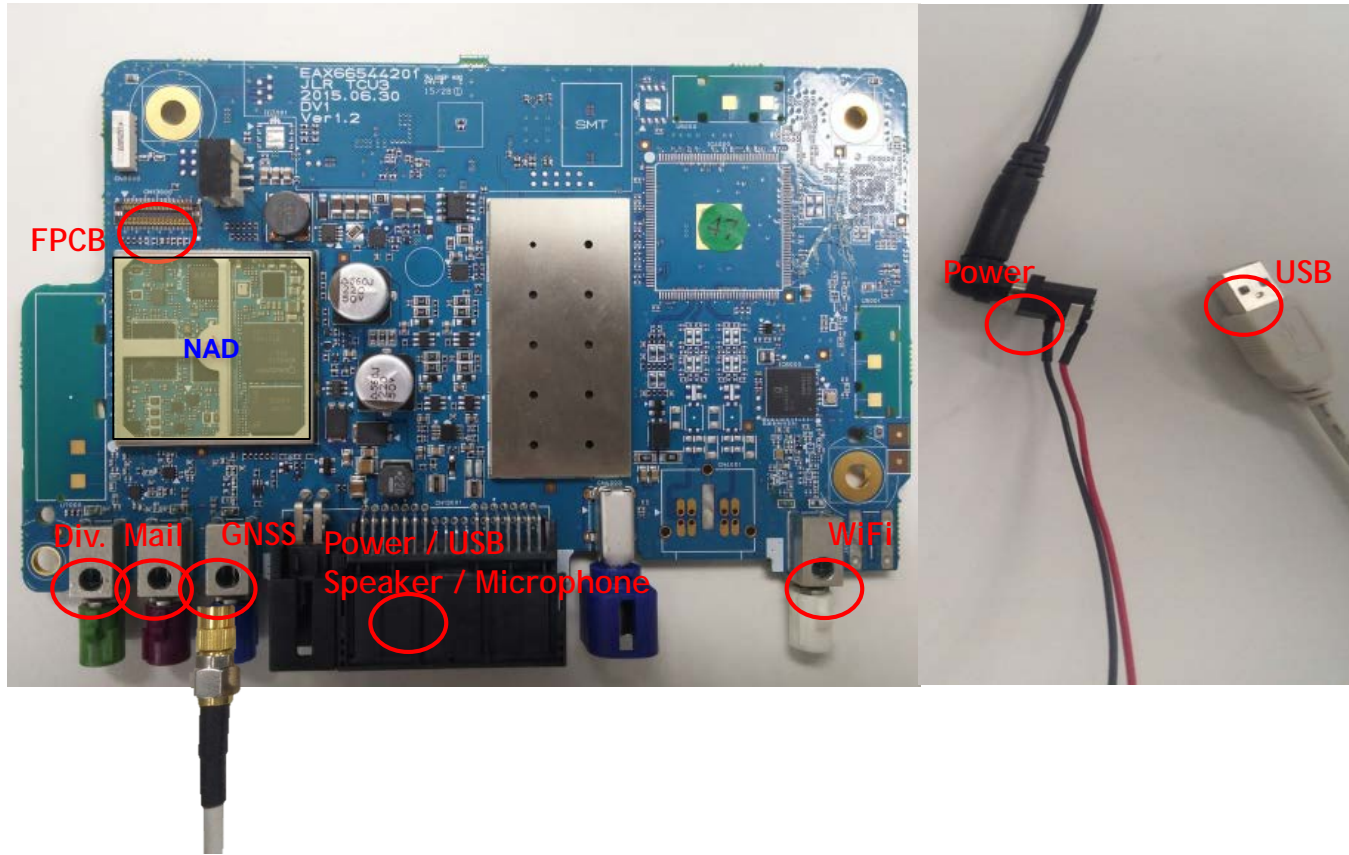

RF Exposure Statement (MPE)

- The antenna(s) must be installed such that a minimum separation distance of at least 20 cm is maintained between the radiator (antenna) and all persons at all times. This device must not be co-located or operating in conjunction with any other antenna or transmitter.

FCC Part 15.19 Statements

- This device complies with Part 15 of the FCC Rules. Operation is subject to the following two conditions: (1) this device may not cause harmful interference, and (2) this device must accept any interference received, including interference that may cause undesired operation.

FCC Part 15.21 statement

- Any changes or modifications not expressly approved by the party responsible for compliance could void the user's authority to operate this equipment.