

Important Safety Precautions

Read these simple guidelines. Breaking the rules may be dangerous or illegal. Further detailed information is given in this user guide.

Warning

Violation of the instructions may cause serious injury or death.



- Never use an unapproved battery since this could damage the phone and/or battery and could cause the battery to explode.



- Never place your phone in a microwave oven as it will cause the battery to explode.
- Never store your phone in temperatures less than -4°F or greater than 122°F.
- Do not dispose of your battery near fire or with hazardous or flammable materials.



- When riding in a car, do not leave your phone or set up the hands-free kit near the air bag. If wireless equipment is improperly installed and the air bag is deployed, you may be seriously injured.



- Do not use a hand-held phone while driving.
- Do not use the phone in areas where its use is prohibited. (For example: aircraft)

Important Safety Precautions



- Do not expose the battery charger or adapter to direct sunlight or use it in places with high humidity, such as a bathroom.



- Do not use harsh chemicals (such as alcohol, benzene, thinners, etc.) or detergents to clean your phone. This could cause a fire.



- Do not drop, strike, or shake your phone severely. It may harm the internal circuit boards of the phone.



- Do not use your phone in high explosive areas as the phone may generate sparks.



- Do not damage the power cord by bending, twisting, pulling, or heating. Do not use the plug if it is loose as it may cause electric shock or fire.



- Do not place any heavy items on the power cord. Do not allow the power cord to be crimped as it may cause electric shock or fire.
- Do not handle the phone with wet hands while it is being charged. It may cause an electric shock or seriously damage your phone.
- Do not disassemble the phone.



- Do not place or answer calls while charging the phone as it may short-circuit the phone and/or cause electric shock or fire.
- Do not hold or let the antenna come in contact with your body during a call.



- Make sure that no sharp-edged items, such as animal's teeth or nails, come into contact with the battery. This could cause a fire.



- Store the battery out of reach of children.
- Be careful that children do not swallow any parts (such as earphone, connection parts of the phone, etc.) This could cause asphyxiation or suffocation resulting in serious injury or death.



- Unplug the power cord and charger during lightning storms to avoid electric shock or fire.



- Only use the batteries and chargers provided by LG. The warranty will not be applied to products provided by other suppliers.

- Only authorized personnel should service the phone and its accessories. Faulty installation or service may result in accidents and consequently invalidate the warranty.



- An emergency call can be made only within a service area. For an emergency call, make sure that you are within a service area and that the phone is turned on.



Table of Contents

Important Safety Precautions	1
Welcome	8
Technical Details	9
Important Information	9
Phone Overview	12
Installing the Battery	14
Removing the Battery	14
Menus Overview	15
Getting Started with Your Phone	18
Charging the Battery	18
Charging with USB	18
Battery Temperature Protection	18
Battery Charge Level	19
Signal Strength	19
Turning the Phone On and Off	19
Turning the Phone On	19
Turning the Phone Off	19
Making Calls	19
Correcting Dialing Mistakes	19
Redialing Calls	19
Receiving Calls	20
Screen Icons	20
Quick Access to Convenient Features	21
Vibrate Mode	21
Sounds Off	21
Mute Function	21
Volume Quick Adjustment	21
Call Waiting	21
Caller ID	21
Voice Commands	21
Entering and Editing Information	22
Text Input	22
Contacts in Your Phone's Memory	23
Storing Basics	23
Customizing Individual Entries	23
Speed Dial	23
Storing a Number with Pauses	24
Adding Another Phone Number	24
Changing the Default Number	25
Deleting	25
Speed Dialing	26
CONTACTS	27
1. New Contact	27
2. Contact List	27
3. Groups	27
4. Speed Dials	28
5. In Case of Emergency (ICE)	28
6. My Name Card	29
7. Favorites	30
MESSAGING	31
1. New Message	31
1.1 TXT Message	32
1.2 Picture Message	34
1.3 Voice Message	36
2. Inbox	36
3. Sent	38
4. Drafts	39

5. Voicemail	39	1.2 My Ringtones	48
6. Wireless Sync Email	40	1.3 My Sounds	48
7. Mobile IM	40	2. Pictures	49
8. Email	40	2.1 Get New Pictures	49
9. Chat	40	2.2 My Pictures	49
Messaging Settings	40	2.3 Take Picture	50
1. Entry Mode (T9 Word/ Abc/ ABC/ 123/ T9 Palabra)	41	2.4 Online Album	51
2. Auto Save Sent (On/ Off/ Prompt)	41	3. Games	51
3. Auto Erase Inbox (On/ Off) ...	41	4. Mobile Web	52
4. Messaging Font Size	41	5. Browse & Download	54
5. TXT Auto View (On/Off)	41	6. Extras	54
6. TXT Auto Scroll (On/Off) ...	41	MY PICTURES	55
7. Multimedia Auto Receive (On/Off)	41	VZ NAVIGATOR	56
8. Quick Text	41	BLUETOOTH	57
9. Voicemail #	41	SETTINGS & TOOLS	58
0. Callback #	41	1. My Verizon	58
*. Signature (None/ Custom) ...	41	2. Tools	58
Erasing Messages	42	2.1 Voice Commands	58
RECENT CALLS	43	2.1.1 Call <Name or Number> ..	59
1. Missed	43	2.1.2 Send Msg to <Name or Number>	59
2. Received	43	2.1.3 Go to <Menu>	59
3. Dialed	44	2.1.4 Check <Item>	59
4. All	44	2.1.5 Contacts <Name>	60
5. View Timers	45	2.1.6 My Verizon	60
MY RINGTONES	46	2.1.7 Help	60
MEDIA CENTER	47	2.2 Calculator	60
1. Tunes & Tones	47	2.3 Ez Tip Calculator	60
1.1 Get New Ringtones	47	2.4 Calendar	61
		2.5 Alarm Clock	62
		2.6 Stopwatch	62



Table of Contents

2.7 World Clock	62	5.7 Font Size	74
2.8 Notepad	63	5.8 Menu Fonts	74
2.9 USB Mass Storage	63	5.9 Clock Format	75
3. Bluetooth® Menu	63	6. Phone Settings	75
3.1 Add New Device	64	6.1 Airplane Mode	75
Turn On	65	6.2 Set Shortcuts	76
My Device Info	66	6.2.1 Set My Shortcuts	76
Discovery Mode	66	6.2.2 Set Directional Keys	76
Supported Profiles	67	6.3 Voice Commands	77
Auto Pair Handsfree	67	6.4 Language	77
4. Sounds Settings	68	6.5 Location	77
4.1 Easy Set-up	68	6.6 Current Country	78
4.2 Master Volume	68	6.7 Security	78
4.3 Call Sounds	68	6.7.1 Edit Codes	78
4.3.1 Call Ringtone	69	6.7.2 Restrictions	79
4.3.2 Call Vibrate	69	6.7.3 Phone Lock	79
4.4 Alert Sounds	69	6.7.4 Lock Phone Now	80
4.5 Keypad Volume	70	6.7.5 Reset Default	80
4.6 Digit Dial Readout	70	6.7.6 Restore Phone	80
4.7 Service Alerts	70	6.8 System Select	81
4.8 Power On/Off	70	6.9 NAM Select	81
4.9 Voice Clarity	71	6.0 CDG2	81
5. Display Settings	71	7. Call Settings	81
5.1 Easy Set-up	71	7.1 Answer Options	81
5.2 Banner	71	7.2 Auto Retry	82
5.2.1 Personal Banner	72	7.3 TTY Mode	82
5.2.2 ERI Banner	72	7.4 One Touch Dial	84
5.3 Backlight	72	7.5 Voice Privacy	84
5.4 Wallpaper	73	7.6 DTMF Tones	84
5.5 Display Themes	73	7.7 Assisted Dialing	84
5.6 Main Menu Settings	73	8. Memory	85

9. Phone Info85	10 Driver Safety Tips104
9.1 My Number86	Consumer Information on SAR .107	
9.3 Icon Glossary86	FCC Hearing-Aid Compatibility (HAC) Regulations for Wireless Devices108
9.4 Software Update86	Accessories111
Safety88	LIMITED WARRANTY STATEMENT112
TIA Safety Information88	Glossary115
Exposure to Radio Frequency Signal88	Terminology115
Antenna Care88	Acronyms and Abbreviations ..115	
Phone Operation88	Glossary117
Tips on Efficient Operation89		
Driving89		
Electronic Devices89		
Pacemakers89		
Hearing Aids90		
Other Medical Devices90		
Health Care Facilities90		
Vehicles90		
Posted Facilities90		
Aircraft90		
Blasting Areas90		
Potentially Explosive Atmosphere ..90			
For Vehicles Equipped with an Air Bag91		
Safety Information91		
Charger and Adapter Safety92		
Battery Information and Care92		
Explosion, Shock, and Fire Hazards	93		
General Notice93		
Caution: Avoid potential hearing loss.95		
FDA Consumer Update97		



Welcome

Thank you for choosing the VX7100 cellular phone designed to operate with the latest digital mobile communication technology, Code Division Multiple Access (CDMA). Along with the many advanced features of the CDMA system, such as greatly enhanced voice clarity, this compact phone offers:

- Built-in VGA Camera
- Mobile Web 2.0
- Sleek and Compact Design
- Large, easy-to-read, 8-line backlit LCD with status icons
- Media Center capable for game, wallpaper and ringtone downloads
- 23-key keypad and Directional Key
- Long battery standby and talk time
- Easy operation using menu-driven interface with prompts
- Paging, messaging, Voicemail, caller ID, IM and chat
- Advanced Voice Recognition
- Quick calling functions including, auto answer, auto retry, 999 speed dials, and voice commands
- Flash Wallpaper with fun animations
- Bilingual (English and Spanish) Capability
- Bluetooth® wireless technology (for certain profiles)

NOTE The Bluetooth® word mark and logos are owned by the Bluetooth SIG, Inc. and any use of such marks by LG Electronics is under license. Other trademarks and trade names are those of their respective owners.

NOTE Find the interactive user guide on the web for your convenience where you can freely surf and interactively learn how to use your phone step-by-step. Go to <http://www.verizonwireless.com> -> Support -> Phones & Devices -> then choose your phone model -> then select Equipment Guide.

Important Information

This user's guide provides important information on the use and operation of your phone. Please read this guide carefully prior to using the phone to be able to use your phone to its greatest advantage and to prevent any accidental damage or misuse. Any unapproved changes or modifications will void your warranty.

FCC Part 15 Class B Compliance

This device and its accessories comply with part 15 of FCC rules. Operation is subject to the following two conditions: (1) This device and its accessories may not cause harmful interference, and (2) this device and its accessories must accept any interference received, including interference that causes undesired operation.

Information to User

This equipment has been tested and found to comply with the limits for a Class B digital device, pursuant to part 15 of the FCC Rules. These limits are designed to provide reasonable protection against harmful interference in a residential installation.

This equipment generates, uses and can radiate radio frequency energy and, if not installed and used in accordance with the instructions, may cause harmful interference to radio

communications.

However, there is no guarantee that interference will not occur in a particular installation. If this equipment does cause harmful interference to radio or television reception, which can be determined by turning the equipment off and on, the user is encouraged to try to correct the interference by one or more of the following measures:

- Reorient or relocate the receiving antenna
- Increase the separation between the equipment and receiver
- Connect the equipment into an outlet on a circuit different from that which the receiver is connected.
- Consult the dealer or an experienced radio/TV technician for help.

Modifications not expressly approved by the manufacturer could void the user's authority to operate the equipment under FCC rules.

Technical Details

The VX7100 is an all digital phone that operates on both Code Division Multiple Access (CDMA) frequencies: Cellular services at 800 MHz and Personal Communication Services (PCS) at 1.9 GHz. CDMA technology uses a feature called DSSS (Direct Sequence Spread Spectrum) that enables the phone to keep communication from



being crossed and to use one frequency channel by multiple users in the same specific area. This results in a 10-fold capacity increase when compared with analog mode. In addition, features such as soft / softer handoff, hard handoff, and dynamic RF power control technologies combine to reduce call interruptions. The Cellular and PCS CDMA networks consist of MSO (Mobile Switching Office), BSC (Base Station Controller), BTS (Base Station Transmission System), and MS (Mobile Station).

* TSB -74: Protocol between an IS-95A system and ANSI J-STD-008

1xRTT system receives twice as many subscribers in the wireless

section as IS-95. Its battery life is twice as long as IS-95.

The following table lists some major CDMA standards.

FCC RF Exposure Information

WARNING! Read this information before operating the phone.

In August 1996, the Federal Communications Commission (FCC) of the United States, with its action in Report and Order FCC 96-326, adopted an updated safety standard for human exposure to Radio Frequency (RF) electromagnetic energy emitted by FCC regulated transmitters. Those guidelines are consistent with the safety standard previously set by both U.S. and

CDMA Standard	Designator	Description
Basic Air Interface	TIA/EIA-95A	CDMA Dual-Mode Air Interface
	TSB-74	14.4kbps radio link protocol and inter-band operations
	ANSI J-STD-008	IS-95 adapted for PCS frequency band CDMA2000
	TIA/EIA-IS2000	1xRTT Air Interface
Network	TIA/EIA/IS-634	MAS-BS
	TIA/EIA/IS/651	PCSC-RS
	TIA/EIA/IS-41 -C	Intersystem operations
	TIA/EIA/IS-124	Non-signaling data comm.
Service	TIA/EIA/IS-96-B	Speech CODEC
	TIA/EIA/IS-637	Short Message Service
	TIA/EIA/IS-657	Packet Data
	IS-801	Position Determination Service (gpsOne)
	TIA/EIA/IS-707-A	High Speed Packet Data

international standards bodies. The design of this phone complies with the FCC guidelines and these international standards.

Bodily Contact During Operation

This device was tested for typical use with the back of the phone kept 0.78 inches (2 cm) from the body. To comply with FCC RF exposure requirements, a minimum separation distance of 0.78 inches (2 cm) must be maintained between the user's body and the back of the phone, including the antenna, whether extended or retracted. Third-party belt-clips, holsters, and similar accessories containing metallic components should not be used. Avoid the use of accessories that cannot maintain 0.78 inches (2 cm) distance between the user's body and the back of the phone and have not been tested for compliance with FCC RF exposure limits.

Vehicle-Mounted External Antenna

(Optional, if available.)

To satisfy FCC RF exposure requirements, keep 8 inches (20 cm) between the user / bystander and vehicle-mounted external antenna. For more information about RF exposure, visit the FCC website at www.fcc.gov.

Caution

Use only the supplied antenna. Use of unauthorized antennas (or modifications to the antenna) could impair call quality, damage the phone, void your warranty and/or violate FCC regulations.

Don't use the phone with a damaged antenna. A damaged antenna could cause a minor skin burn.

Contact your local dealer for a replacement antenna.



Phone Overview

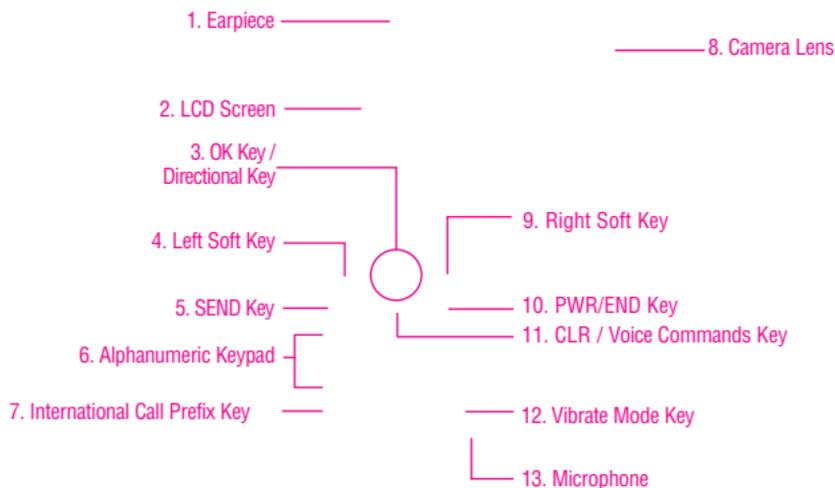

- 1. Earpiece** Lets you hear the caller and automated prompts.
- 2. LCD Screen** Displays messages and indicator icons.
- 3. OK Key / Directional Key** Use the OK Key  to select the function displayed at the bottom of the LCD between the Left and Right Soft Key functions. Use the Directional Key  to scroll through the menu items and highlight a specific field or object by moving up, down, left or right.
- 4. Left Soft Key** Use to access Messaging menu.
- 5. SEND Key** Use to make and answer calls.
- 6. Alphanumeric Keypad** Use to enter numbers and characters and select menu items.
- 7. International Call Prefix Key** To make an international call, press and hold  for 2 or 3 seconds. + is the international calling code.
- 8. Camera Lens** Used to take a photo. Keep it clean for optimal photo quality.

- 9. Right Soft Key** Use to access Contact List.
- 10. PWR / END Key** Use to turn the power on/off and to end a call. Also returns to standby mode.
- 11. CLR / Voice Commands Key** Deletes single spaces or characters with a quick press, but press and hold to delete entire words. Also backs out of menus, one level at a time. Use for quick access to Voice Commands.
- 12. Vibrate Mode Key** Use to set Vibrate mode (from standby mode press and hold for about 3 seconds).
- 13. Microphone** Allows other callers to hear you clearly when you are speaking to them.
- 14. 2.5 mm Headset Jack** Allows you to plug in an optional headset for convenient, hands-free conversations.
- 15. Side Keys / Volume Keys Up/Down** Use to adjust the Master Volume in standby mode* and the Earpiece Volume during a call.
- 16. Speakerphone Key** Use to change to speakerphone mode.
- 17. Accessory Charger Port** Connects the phone to the battery charger, or other compatible accessory.
- 18. Camera Key** Use for quick access to Camera function. Press the camera key turns the handset in to camera mode to take pictures.

* Standby mode is when the phone is waiting for input from you. No menu is displayed and the phone isn't performing any action. It's the starting point for all of the instruction steps. This User Manual gives navigation instructions according to the default "list" Main Menu Layout in the Display Settings menu. If other themes or menus are set, navigating the phone's menus may be different.

Rear view

Battery

Battery Cover

- NOTES** • It's important to fully charge the battery before using the phone for the first time.
- Battery life and signal strength are significant factors (among others) that affect your phone's ability to send/receive calls.



Installing the Battery

1. Insert the bottom of the battery into the opening on the back of the phone.
2. Push the battery down until it clicks into place.

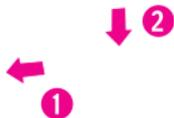

3. Place the battery cover over the opening on the back of the phone, then slide it upward until it clicks into place.



Removing the Battery

1. Turn the phone off, then slide the battery cover downward to remove it.

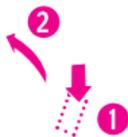

2. Remove the battery from the battery compartment by lifting the top of the battery.





Contacts

1. New Contact
2. Contact List
3. Groups
4. Speed Dials
5. In Case of Emergency
6. My Name Card
7. Favorites



Messaging

1. New Message
 1. TXT Message
 2. Picture Message
 3. Voice Message
2. Inbox
3. Sent
4. Drafts
5. Voicemail
6. Wireless Sync Email
7. Mobile IM
8. Email
9. Chat



Recent Calls

1. Missed
2. Received
3. Dialed
4. All
5. View Timers



My Ringtones



Media Center

1. Tunes & Tones
 1. Get New Ringtones
 2. My Ringtones
 3. My Sounds
2. Pictures
 1. Get New Pictures
 2. My Pictures
 3. Take Picture
 4. Online Album
3. Games
4. Mobile Web
5. Browse & Download
6. Extras



My Pictures



VZ Navigator



Bluetooth



Settings & Tools

1. **My Verizon**
2. **Tools**
 1. Voice Commands
 2. Calculator
 3. Ez Tip Calculator
 4. Calendar
 5. Alarm Clock
 1. Alarm 1
 2. Alarm 2
 3. Alarm 3
 6. Stopwatch
 7. World Clock
 8. Notepad
 9. USB Mass Storage
3. **Bluetooth Menu**
 1. Add New Device
4. **Sounds Settings**
 1. Easy Set-up
 2. Master Volume
 3. Call Sounds
 1. Call Ringtone
 2. Call Vibrate
 3. Call Alert
 4. Alert Sounds
 1. TXT Message
 2. Multimedia Message
 3. Voicemail
 4. Emergency Tone
 5. Missed Call
5. **Keypad Volume**
6. **Digit Dial Readout**
7. **Service Alerts**
 1. ERI
 2. Minute Beep
 3. Call Connect
 4. Charge Complete
8. **Power On/Off**
 1. Power On
 2. Power Off
9. **Voice Clarity**
5. **Display Settings**
 1. Easy Set-up
 2. Banner
 1. Personal Banner
 2. ERI Banner
 3. Backlight
 1. Display
 2. Keypad
 4. Wallpaper
 1. My Pictures
 2. Fun Animations
 5. Display Themes
 6. Main Menu Settings
 7. Font Size
 8. Menu Font
 9. Clock Format
6. **Phone Settings**
 1. Airplane Mode
 2. Set Shortcuts
 3. Voice Commands
 4. Language
 5. Location
 6. Current Country
 7. Security

1. Edit Codes
 2. Restrictions
 3. Phone Lock
 4. Lock Phone Now
 5. Reset Default
 6. Restore Phone
 8. System Select
 9. NAM Select
 10. CDG2
- 7. Call Settings**
1. Answer Options
 2. Auto Retry
 3. TTY Mode
 4. One Touch Dial
 5. Voice Privacy
 6. DTMF Tones
 7. Assisted Dialing
- 8. Memory**
- 9. Phone Info**
1. My Number
 2. SW/HW Version
 3. Icon Glossary
 4. Software Update
- 10. Set-up Wizard**

Some content in this user guide may differ from your phone depending on the phone software. Features and specifications are subject to change without prior notice.



Charging the Battery

To use the charger provided with your phone:

NOTICE Please use only an approved charging accessory to charge your LG phone. Improper handling of the charging port, as well as the use of an incompatible charger, may cause damage to your phone and void the warranty.

1. Plug the end of the AC adapter into the phone's charger port and the other end into an electrical outlet.



NOTICE

Please make sure that the LG logo faces down before inserting a charger or data cable into the charger port of your phone.

2. The charge time varies depending upon the battery level.

Charging with USB

You can use your computer to charge your phone. Connect one end of the USB cable to the charging accessory port on your phone and the other end to a highpower USB port on your PC. But prior to do these steps, you need to have proper USB drivers. LG USB Driver is downloadable below site; <http://us.lge.com> > Click SUPPORT > Click DOWNLOAD and search for LG USB Driver.

NOTE Low power USB port is not supported, such as the USB port on your keyboard or bus-powered USB hub. USB driver should be installed before charging with USB.

Battery Temperature Protection

If the battery gets overheated, the phone will automatically turn off. When you turn the phone back on, a message pops up alerting you that the phone was powered off for your safety.

Battery Charge Level

You can find the battery charge level  at the top right of the LCD screen. When the charge level becomes low, the battery sensor sounds a warning tone, blinks the battery icon, and displays a warning message. As the charge level approaches empty, the phone automatically switches off without saving.

Signal Strength

Call quality depends on the signal strength in your area. You can tell how much signal strength you have by the number of bars next to the signal strength icon:  the more bars, the stronger the signal. If you're having problems with signal quality, move to an open area or, when inside a building, try moving near a window.

Turning the Phone On and Off

Turning the Phone On

1. Install a charged battery or connect the phone to an external power source.
2. Press  (located above the  key on the keypad) until the LCD screen lights up.

Turning the Phone Off

Press and hold  until the display turns off.

Making Calls

1. Make sure the phone is turned on.
If not, open the flip and press  for about three seconds.
If necessary, enter the lock code.
2. Enter the phone number.
3. Press  .
4. Press  to end the call.

NOTE Your phone has a Voice Commands feature that also lets you make calls by saying a phone number, name, or location.

Correcting Dialing Mistakes

Press  once to erase the last digit entered, or hold it down for at least two seconds to delete all the digits.

Redialing Calls

Press  twice to redial the last number dialed.



Receiving Calls

1. When the phone rings or vibrates, you can answer the call by simply opening the flip.

NOTE If the Answer Options setting is set to Any Key, you can:

- Open the flip and press the Left Soft Key  **[Quiet]** to mute the ringing or vibration for that call.
- Open the flip and press the Right Soft Key  **[Ignore]** to end the call or send it directly to Voicemail.

2. Press  to end the call, or simply close the flip.

Screen Icons

When the phone is on, the top line of the LCD screen displays phone status icons.

To see the icon glossary, with the flip open, go to **MENU -> Settings & Tools -> Phone Info -> Icon Glossary** on your phone.

Quick Access to Convenient Features

Vibrate Mode

Sets the phone to vibrate instead of ring (🔔 is displayed). To set Vibrate Mode, Press and hold . To return to Normal Mode, press and hold .

Sounds Off

Quickly deactivate your phone's sounds when you're in a place where phone sounds would be disruptive. From standby mode Press and hold the lower side volume key for 3 seconds. To return to normal sounds mode, press and hold the upper side key.

Mute Function

The Mute Function prevents the transmission of your voice to the caller. To quickly activate Mute while in a call, press the Left Soft Key  **[Mute]**, then to unmute press the Left Soft Key  **[Unmute]**.

Volume Quick Adjustment

Quickly adjust ringer and earpiece volumes by pressing the upper side volume key  on the left side of the phone to increase and lower volume side key to decrease.

NOTE The earpiece volume can only be adjusted during a call and Key Beep volume can only be adjusted through the Menu.

Call Waiting

During a call, one beep indicates another incoming call. Press  to answer it and put the first call on hold. Press  again to return to the first call.

Caller ID

Caller ID displays the number and/or name and/or picture if applicable of the person calling when your phone rings.

Voice Commands

Voice Commands allow you to do things by verbal command (e.g., make calls, confirm Voicemail, etc.). Press the Voice Commands Key  (on the left side of the phone) and follow the prompts.

NOTE Voice Commands can also be started with the designated key on your Bluetooth® device. Please check the manual of the Bluetooth® device for further instructions.

Text Input

The following key functions are available to help with text entry:

-  **Left Soft Key:** Press to change text input mode.
-  **Shift:** Press to change capitalization (initial cap, caps lock, lowercase).
-  **Next:** Press to display other matching words in the database in T9 word mode.
-  **Space:** Press to complete a word and insert a space.
-  **Clear:** Press to delete a single space or character. Hold to delete words.
-  **Punctuation:** Press to insert punctuation.

Text Input Modes

In a text field, press the Left Soft Key  to display text modes.

**T9 Word/ Abc/ ABC/ 123/ Symbols/
Quick Text/ T9 Palabra**

Storing Basics

1. With the flip open, enter a number (max. 48 digits), then press the Left Soft Key  [**Save**].
2. Use the Directional Key  to highlight **Add New Contact/Update Existing**, then press .
3. Use the Directional Key  to highlight **Mobile 1/ Home/ Work/ Mobile 2/ Fax**, then press .
4. Enter a name (max. 32 characters), then press .
5. Press  to exit,  to call, or the Right Soft Key  [**Options**].

Customizing Individual Entries

1. Press the Right Soft Key  [**Contacts**], then use the Directional Key  to highlight an entry.
2. Press the Left Soft Key  [**Edit**].
3. Use the Directional Key  to highlight the information to customize.
4. Change the entry as you want, then press  to save your changes.

Speed Dial

Allows you to set up your Speed Dials.

1. Press the Right Soft Key  [**Contacts**], then use the Directional Key  to highlight an entry.
2. Press the Left Soft Key  [**Edit**].
3. Use the Directional Key  to highlight a phone number, then press the Right Soft Key  [**Options**].
4. Use the Directional Key  to highlight **Set Speed Dial**, then press .
5. Enter a Speed Dial digit.
 - Use the keypad, then press .
 - Use the Directional Key  to highlight the Speed Dial digit, then press .
6. Press  **Yes** to confirm, then press  to save.



Storing a Number with Pauses

Pauses allow you to enter additional series of numbers to access automated systems such as Voicemail or credit billing numbers. Pause types are: **Wait (W)** The phone stops dialing until you press the Left Soft Key  **[Release]** to advance to the next number. **2-Sec Pause (P)** The phone waits two seconds before sending the next string of digits.

1. With the flip open, enter the number, then press the Right Soft Key  **[Options]**.
2. Use the Directional Key  to highlight **2-Sec Pause or Wait**, then press .
3. Enter additional number(s) (e.g., pin number, credit card number, etc.).
4. Press the Left Soft Key  **[Save]**.
5. Choose Add **New Contact/Update Existing**.
6. Choose **Mobile 1/Home/Work/Mobile 2/Fax**.
7. Continue entering information for the Contact entry as necessary.

Adding Another Phone Number

From standby mode

1. With the flip open, enter a phone number, then press the Left Soft Key  **[Save]**.
2. Use the Directional Key  to highlight **Update Existing**, then press .
3. Use the Directional Key  to highlight an existing entry, then press .
4. Use the Directional Key  to highlight **Mobile 1/ Home/ Work/ Mobile 2/ Fax**, then press  to save.

From the Contact List Screen

1. Press the Right Soft Key  **[Contacts]**.
2. Use the Directional Key  to highlight an entry, then press the Left Soft Key  **[Edit]**.
3. Use the Directional Key  to highlight the phone number field to add, then enter the number and press  to save.

Changing Saved Information

To edit any information you stored, access the Edit Contacts screen:

1. Press the Right Soft Key  **[Contacts]**.
2. Use the Directional Key  to highlight a Contact entry, then press the Left Soft Key  **[Edit]**.
3. Use the Directional Key  to highlight the field you want to change.
4. Make the changes, then press .

Adding a Pause to a Contact Entry

1. Press the Right Soft Key  **[Contacts]**.
2. Use the Directional Key  to highlight a Contact entry, then press the Left Soft Key  **[Edit]**.
3. Use the Directional Key  to highlight the number, then press the Right Soft Key  **[Options]**.
4. Press  **Wait** or  **2-Sec Pause**.
5. Enter additional number(s), then press .

Changing the Default Number

The Default Number is the phone number you entered when you created the Contact. Another number can be saved as the Default Number.

1. Press the Right Soft Key  **[Contacts]**.
2. Use the Directional Key  to highlight an entry.
3. Press the Left Soft Key  **[Edit]**.
4. Use the Directional Key  to highlight a phone number, then press the Right Soft Key  **[Options]**.
5. Use the Directional Key  to highlight **Set As Default**, then press .
6. Press  **Yes** to set the new number as the default. A confirmation message is displayed.
7. Press  again to save.

Deleting

Deleting a Contact Entry

1. Press the Right Soft Key  **[Contacts]**.
2. Use the Directional Key  to highlight an entry.



3. Press the Right Soft Key  **[Options]**.
4. Press  **Erase**.
5. Press  **Yes** to confirm.

Deleting a Speed Dial

1. Press the Right Soft Key  **[Contacts]**.
2. Use the Directional Key  to highlight a Contact entry to edit and press  **[VIEW]**.
3. Select the phone number with the Speed Dial, then press  **[EDIT]**.
4. Press the Right Soft Key  **[Options]**.
5. Press  **Remove Speed Dial**.
6. Press  **Yes** to confirm.
7. Press  again to save.

Speed Dialing

Allows you to make phone calls quickly and easily to numbers stored in Contacts.

NOTE Speed Dial 1 is for Voicemail. Speed Dial 411 is for Directory Assistance.

Single Digit Speed Dials

Press and hold the Speed Dial digit. Your phone recalls the phone number from your Contacts, displays it, and dials it for you.

Multiple Digit Speed Dials

When you press and hold a number key, it signals the phone to attempt a Speed Dial transmission. To dial Speed Dials with multiple digits, press the first digit(s) as necessary, then press and hold the last digit. For example, to Speed Dial 25, press , then press and hold .

NOTE You can also enter the Speed Dial digit(s), then press .

Speed Dials 95, 96, 97, 98, and 99

Speed Dials 95, 96, 97, 98, and 99 are preset to access certain phone account information: 95 (#Warranty Center), 96(#Data), 97 (#BAL), 98 (#MIN), and 99 (#PMT). Unlike Speed Dial 1, these can be changed if you want.

NOTE 411 is not available for **Set** or **Remove**.

CONTACTS

The Contacts Menu allows you to store names, phone numbers and other information in your phone's memory.

SHORTCUT Pressing the Right Soft Key  is a hot key to Contact List.

1. New Contact

Allows you to add a new number to your Contact List.

NOTE Using this submenu, the number is saved as a new Contact, not into an existing Contact.

1. Press  **[MENU]**.
2. Press  **Contacts**.
3. Press  **New Contact**.
4. Enter the name and press the Directional Key  downward.
5. Use the Directional Key  to highlight the phone number type.
6. Enter the number and press .

NOTE For more detailed information, see page 23.

2. Contact List

Allows you to view your Contact List.

1. Press  **[MENU]**.
2. Press  **Contacts**.
3. Press  **Contact List**.
4. Use the Directional Key  to scroll through your Contacts alphabetically.
 - Press the Right Soft Key  **[Options]** to select one of the following:
New Contact/ Erase/ New TXT Message/ New Picture Message/ New Voice Message/ Set As ICE Contact/ Call/ Erase All/ Send Name Card
 - Press the Left Soft Key  **[Edit]** to edit.
 - Press  to view the entry details.

TIP Use the **Go To** field, for quick access to an entry without scrolling. For example, to go to "Vet", enter the letter V.

3. Groups

Allows you to view your grouped Contacts, add a new group, change the name of a group, delete a group, or send a message to everyone in the selected group.

1. Press  **[MENU]**.
2. Press  **Contacts**.
3. Press  **Groups**.

4. View a Group

Use the Directional Key  to highlight a group, then press .

Add a New Group

Press the Left Soft Key  **[New]** to add a new group to the list.

Options Using a Group

Press the Right Soft Key  **[Options]** to select one of the following:

New TXT Message/ New Picture Message/ New Voice Message/ Rename/ Erase/ Add/ Send Name Card

4. Speed Dials

Allows you to view your list of Speed Dials or designate Speed Dials for numbers entered in your Contacts.

1. Press  **[MENU]**.
2. Press  **Contacts**.
3. Press  **Speed Dials**.
4. Use the Directional Key  to highlight the Speed Dial position, or enter the Speed Dial digit and press  **[SET]**.
5. Use the Directional Key  to highlight the Contact then press . (For Contacts with multiple numbers, highlight the number for the Speed Dial, then press .)
6. Press  **Yes** to confirm. A confirmation message is displayed.

5. In Case of Emergency (ICE)

This menu allows you to store names, phone numbers and other information, which will be very helpful in case of emergency. Also, it allows you to add, read, edit, or erase the notes about yourself as necessary in case an emergency takes place.

1. Press  **[MENU]**.
2. Press  **Contacts**.
3. Press  **In Case of Emergency**.
4. Use the Directional Key  to highlight **Contact 1, 2, or 3**, then press  **[ADD]**.
5. Press  to add Contact from your Contact List.

Highlight the Contact, then press .

ICE CONTACT ASSIGNED is displayed.

OR

Press  to enter information not stored in your Contact List.

6. The generic Contact label changes to the specified name.

Entering Your ICE Personal Info

1. Press  **[MENU]**.
2. Press  **Contacts**.
3. Press  **In Case of Emergency**.
4. Use the Directional Key  to highlight **Personal Info**, then press .
5. Use the Directional Key  to highlight one of the **Note** entries, then press .
6. Enter information that would be helpful in an emergency (e.g., your medical record number), then press .

TIP When you've assigned ICE Contacts and your phone is locked, the Left Soft Key  appears as **[ICE]** allowing the emergency information to be viewed without unlocking the phone.



6. My Name Card

Allows you to view all of your personal Contact information including name, phone numbers, and email address in one entry.

1. Press  **[MENU]**.
2. Press  **Contacts**.
3. Press  **My Name Card**.
4. Press  **[EDIT]** to enter your personal Contact information.
5. Use the Directional Key  to scroll to the information you want to enter.
6. Enter your information as necessary, then press .

NOTE Press the Right Soft Key  **[Options]** to send your name card.

7. Favorites

Allows you to view all of your personal Contact information including name, phone numbers, and email address in one entry.

1. Press  **[MENU]**.
2. Press  **Contacts**.
3. Press  **Favorites**.
4. Press  **[ADD]**

MESSAGING

SHORTCUT

From standby mode, pressing the Left Soft Key  is a hot key to your MESSAGING.

Text messages, Picture messages, and the Voicemail box become available as soon as the phone is powered on.

- Check types of messages by pressing the Left Soft Key  [Messaging].
- Make a call to the callback number (in Inbox) by pressing  during a message check.

Depending on the content and size of your messages, the phone can store well over 540 messages. The information stored in the message is determined by phone model and service capability. Other limits to available characters per message may exist. Please check with your service provider for system features and capabilities.

New Message Alert

Your phone will alert you when you have new messages.

1. The phone displays a message on the screen.
2. The message icon () is displayed on the display screen. In the case of a high priority message, the icon will blink.

1. New Message

Allows you to send messages (Text, Picture, and Voice). Each message has a destination (Address) and information (Message). These are dependent upon the type of message you want to send. You can also attach files to your messages including pictures, sounds, and name cards.



1.1 TXT Message

The Basics of Sending a Text Message

1. Press the Left Soft Key  [Message].
2. Press  **New Message**.
3. Press  **TXT Message**.
4. Enter the phone number of the recipient or the email address for an email message. You can enter up to 10 addresses for a single message.
5. Press the Directional Key  downward.
6. Type your message in the text field.
7. Press  [SEND].

Customizing the Message Using Options

● Editing the To: field

1. With the To field highlighted, press the Right Soft Key  [Add].
2. Select the option(s) to customize.

From Contacts/ Recent Calls/ Groups

● Editing Text

1. With the Text field highlighted, press the Right Soft Key  [Options].
2. Select the option(s) to customize.

Insert Quick Text Allows you to add Quick Text.

Save As Draft Saves the message into the Drafts folder.

Add Allows you to add Graphic, Animation, Sound, Signature, Name Card, or Address From Contacts .

Copy Text Allows you to copy text.

Paste Allows you to paste the text you last copied into a text field.

Format Text Allows you to change the look of the text.

Alignment/ Font Size/ Font Style/ Text Color/ Background

Priority Level Gives priority to the message.

High/ Normal

Callback # Inserts a pre-programmed callback number with your message.

On/ Off/ Edit

Save Quick Text Allows you to save the message as a Quick Text.

Cancel Message Cancels message editing and goes to the previous menu.

3. Complete and then send the message.

Using Contacts to Send a Message

You can designate an entry saved in your Contacts as the address instead of manually entering the destination.

1. Press the Left Soft Key  **[Message]**.
2. Press  **New Message**.
3. Press  **TXT Message**.
4. Press the Right Soft Key  **[Add]**.
5. Use the Directional Key  to highlight **From Contacts** and press .
6. Use the Directional Key  to highlight the Contact entry containing the destination and press  to mark the contact.
7. Press the Left Soft Key  **[Done]**.

NOTE The Address feature allows multi-sending of up to 10 total addresses.

8. Complete the message as necessary.



1.2 Picture Message

The Basics of Sending a Picture Message

1. Press the Left Soft Key  **[Message]**.
 2. Press  **New Message**.
 3. Press  **Picture Message**.
 4. Enter the cellular phone number or email address of the recipient.
 5. Press the Directional Key  downward.
 6. Type your message in the text field.
 7. Use the Directional Key  to highlight **Picture** and press the Left Soft Key  **[My Pics]**. Use the Directional Key  to select the image you want to send, then press .
 8. Use the Directional Key  to highlight **Sound**, then press the Left Soft Key  **[Sounds]**. Use the Directional Key  to highlight the audio file you want to send then press .
 9. Use the Directional Key  to highlight **Name Card**, then press the Left Soft Key  **[Contacts]**. Use the Directional Key  to choose **My Name Card/ From Contacts**.
 10. Use the Directional Key  to highlight **Subject** and enter the subject.
 11. Press  **[SEND]**.
A confirmation message is displayed.
- **Editing the To: field**
 1. With the To field highlighted, press the Right Soft Key  **[Add]**.
 2. Select the option(s) to customize.
From Contacts/ From Recent Calls/ Groups/ To Online Album/ To Contacts
 - **Editing Text**
 1. With the Text field highlighted, press the Right Soft Key  **[Options]**.
 2. Select the option(s) to customize.
Preview Displays the Picture message as it would be seen by the recipient.

Save As Draft Saves the message into the Drafts folder.

Insert Quick Text Allows you to add Quick Text.

Copy Text Allows you to copy the input text.

Paste Allows you to paste the text you last copied into a text field.

Add Slide Insert multiple pictures into a picture message.

Priority Level Gives priority to the message.

High/ Normal

Cancel Message Cancels message editing and goes to Messaging menu.

● **Editing Picture**

1. With the Picture field highlighted, press the Right Soft Key  **[Options]**.
2. Select the option(s) to customize. **Preview/ Save As Draft/ Add Slide/ Priority Level/ Remove Picture/ Cancel Message**

● **Editing Sound**

1. With the Sound field highlighted, press the Right Soft Key  **[Options]**.
2. Select the option(s) to customize. **Preview/ Save As Draft/ Add Slide/ Priority Level/ Remove Sound/ Cancel Message**

● **Editing Name Card**

1. With the Name Card field highlighted, press the Right Soft Key  **[Options]**.
2. Select the option(s) to customize. **Preview/ Save As Draft/ Add Slide/ Priority Level/ Remove Name Card/ Cancel Message**

● **Editing a Subject**

1. With the Subject field highlighted, press the Right Soft Key  **[Options]**.
2. Select the option(s) to customize. **Preview/ Save As Draft/ Insert Quick Text/ Add Slide/ Priority Level/ Cancel Message**



1.3 Voice Message

The Basics of Sending a Voice Message

1. Press the Left Soft Key  **[Message]**.
2. Press  **New Message**.
3. Press  **Voice Message**.
4. Press  to start recording.
5. Record your voice message.
6. Press  to end recording.
7. Enter the cellular phone number or email address of the recipient.
8. Press the Directional Key  downward.
9. Type your message.
10. Use the Directional Key  to highlight **Name Card**, then press the Left Soft Key  **[Contacts]**. Use the Directional Key  to choose **My Name Card/ From Contacts**.
11. Use the Directional Key  to highlight **Subject** and enter the subject.
12. Press  **[SEND]**.

After a connecting display, message is transmitted.

2. Inbox

The phone alerts you in 3 ways when you receive a new message:

- By displaying a notification message on the screen.
- By sounding a sound or vibration, if set.
- By displaying . (The icon will blink when you get a high priority message.)

Viewing Your Inbox

1. Press the Left Soft Key  **[Message]**.
2. Press  **Inbox**.
3. Options from here with a message highlighted:
 - Press  **[OPEN]** to view the message.
 - Press the Left Soft Key  **[Erase]** to erase the highlighted message.
 - Press the Right Soft Key  **[Options]** to access the options.

Reply Replies to the origination address of the received message.

Reply With Copy Replies to the origination address with a copy of the original message attached.

Forward Forwards a received message to other destination address(es).

Add To Contacts Stores the callback number, email address, and numbers from the address of the received message into your Contacts.

Extract Addresses Allows you to extract addresses.

Sort By Sender/Time Allows you to sort messages alphabetically by sender's name or by time received.

Manage Inbox Allows you to manage (lock or erase) message list.

Message Info Allows you to check the received message information.

Message Icon Reference



New/ Unread TXT Messages



Opened/ Read TXT Messages



Priority High



Locked



New/ Unread Multimedia Message



Open/ Read Multimedia Message



New/Unread Browser Messages



Opened/Read Browser Messages



New/Unread Notification Messages



Open/Read Notification Messages

* Multimedia Message indicates Picture/ Voice Message.

3. Sent

Depending on the content and size of your messages, you can save up to 100 Sent messages. This menu lists your Sent messages. Use it to verify whether the transmission was successful or not and view message contents.

1. Press the Left Soft Key  **[Message]**.
2. Press  **Sent**.
3. Options from here with a message highlighted:
 - Press  **[OPEN]** to view the message.
 - Press the Left Soft Key  **[Erase]** to erase highlighted message.
 - Press the Right Soft Key  **[Options]**.

Forward Forwards a sent message to other destination address(es).

Send Allows you to retransmit the selected message.

Add To Contacts Stores the callback number, email address, and numbers from the address of the message into your Contacts.

Sort By Recipient/Time Allows you to sort alphabetically by recipient's name or by time sent.

Manage Sent Allows you to manage (erase or lock) message list.

Message Info Allows you to check the sent message information.

Message Icon Reference

-  Text/Picture/Voice Messages sent
-  Message delivered
-  Text/Picture/Voice Messages failed
-  Multiple Messages sent
-  Multiple Messages delivered
-  Multiple Messages failed
-  Multiple Messages incomplete
-  Priority High
-  Locked

4. Drafts

Displays draft messages.

1. Press the Left Soft Key  **[Message]**.
2. Press  **Drafts**.
3. Options from here with a message highlighted:
 - Press  **[EDIT]** to continue editing the message.
 - Press the Left Soft Key  **[Erase]**.
 - Press the Right Soft Key  **[Options]**.

Send Sends the selected message.

Add To Contacts Stores the callback number, email address, and numbers from the address included in the message into your Contacts.

Manage Drafts Allows you to manage (erase or lock) messages.

Message Icon Reference



Draft TXT



Draft Multimedia Message

5. Voicemail

Allows you to view the number of new voice messages recorded in the Voicemail box. Once you exceed the storage limit, old messages are overwritten. When you have a new voice message, your phone will alert you.

Checking Your Voicemail Box

1. Press the Left Soft Key  **[Message]**.
2. Press  **Voicemail**.
3. Options from here :
 - Press the Left Soft Key  **[Clear]** to delete information, and then press  **[Yes]**.
 - Press  or  **[CALL]** to listen to the message(s).

OR

1. Dial 86 (VM)  from your phone or dial your wireless phone number from any touch-tone phone.
2. When the recorded announcement begins, press  to interrupt (if applicable).
3. When prompted, enter your password, then .



6. Wireless Sync Email

1. Press the Left Soft Key  **[Message]**.
2. Press  **Wireless Sync Email**.

7. Mobile IM

Allows you to send and receive an Instant Message at any time.

1. Press the Left Soft Key  **[Message]**.
2. Press  **Mobile IM**.

8. Email

Allows you to send an email via Mobile Web.

1. Press the Left Soft Key  **[Message]**.
2. Press  **Email**.
3. A Mobile Web Browser session starts.
4. Highlight an email provider and press .
5. Login or enter your email address and password.

9. Chat

Allows you to chat with Internet Messenger users.

1. Press the Left Soft Key  **[Message]**.
2. Press  **Chat**.
3. A Mobile Web Browser session starts.
4. Highlight a Chat provider and press .

NOTE This feature may require a subscription to a Chat service provider.

Messaging Settings

Allows you to configure settings for your messages.

1. Press the Left Soft Key  **[Message]**.
2. Press the Left Soft Key  **[Settings]**.
3. Use the Directional Key  to highlight one of the settings and press  to select it.

Message Settings Sub-Menu Descriptions

1. Entry Mode (T9 Word/ Abc/ ABC/ 123/ T9 Palabra)

Allows you to select the default input mode including Word, Abc, ABC, 123, T9 Palabra.

2. Auto Save Sent (On/ Off/ Prompt)

With this feature on, messages are automatically saved in the Sent folder when transmitted.

3. Auto Erase Inbox (On/ Off)

With this feature on, read messages are automatically deleted when you exceed the storage limit.

4. Messaging Font Size

Allows you to set the message font size. Choose Normal or Large.

5. TXT Auto View (On/Off)

Allows the phone to directly display the content when receiving a message.

6. TXT Auto Scroll (On/Off)

Allows the display to automatically scroll while viewing messages.

7. Multimedia Auto Receive(On/Off)

Allows you to directly download the content when receiving a Picture, or Voice message.

8. Quick Text

Allows you to display, edit, and add text phrases. These text strings allow you to reduce manual text input into messages.

9. Voicemail #

Allows you to manually enter the access number for Voicemail Service. This feature should be only used when a VMS (Voicemail Service) access number is not provided from the network.

0. Callback #

Allows you to automatically send a designated callback number when you send a message.

***. Signature (None/ Custom)**

Allows you make/edit a signature to automatically send with your messages.



Erasing Messages

Allows you to erase messages stored in your Inbox, Sent, or Drafts folders. You can also erase all messages at the same time.

1. Press the Left Soft Key  **[Message]**.
2. Press the Right Soft Key  **[Options]** then select one of the following:

Erase Inbox/ Erase Sent/ Erase Drafts/ Erase All

3. Press  to erase the messages selected.
4. Press  to confirm the deletion.

A confirmation message is displayed.

RECENT CALLS

The Recent Calls Menu is a list of the last phone numbers or Contact entries for calls you placed, accepted, or missed. It's continually updated as new numbers are added to the beginning of the list and the oldest entries are removed from the bottom of the list.

1. Missed

Allows you to view the list of missed calls; up to 90 entries.

1. Press  **[MENU]**.
2. Press  **Recent Calls**.
3. Press  **Missed**.
4. Use the Directional Key  to highlight an entry, then
 - Press  to open the entry.
 - Press  to place a call to the number.
 - Press the Right Soft Key  **[Options]** to select: **Save To Contacts (Details)/ Erase/ Lock(Unlock)/ Erase All/ View Timers**

- Press the Left Soft Key  **[Message]** to select: **TXT Message/ Picture Message/ Voice Message**

2. Received

Allows you to view the list of incoming calls; up to 90 entries.

1. Press  **[MENU]**.
2. Press  **Recent Calls**.
3. Press  **Received**.
4. Use the Directional Key  to highlight an entry, then
 - Press  to open the entry.
 - Press  to place a call to the number.
 - Press the Right Soft Key  **[Options]** to select: **Save To Contacts (Details)/ Erase/ Lock(Unlock)/ Erase All/ View Timers**
 - Press the Left Soft Key  **[Message]** to select: **TXT Message/ Picture Message/ Voice Message**



RECENT CALLS

3. Dialed

Allows you to view the list of outgoing calls; up to 90 entries.

1. Press  **[MENU]**.
2. Press  **Recent Calls**.
3. Press  **Dialed**.
4. Use the Directional Key  to highlight an entry, then
 - Press  to open the entry.
 - Press  to place a call to the number.
 - Press the Right Soft Key  **[Options]** to select:
Save to Contacts(Details)/ Erase/ Lock(Unlock)/ Erase All/ View Timers
 - Press the Left Soft Key  **[Message]** to select:
TXT Message/ Picture Message/ Voice Message

4. All

Allows you to view the list of all calls; up to 270 entries.

1. Press  **[MENU]**.
2. Press  **Recent Calls**.
3. Press  **All**.
4. Use the Directional Key  to highlight an entry, then
 - Press  to open the entry.
 - Press  to place a call to the number.
 - Press the Right Soft Key  **[Options]** to select:
Save to Contacts(Details)/ Erase/ Lock(Unlock)/ Erase All/ View Timers
 - Press the Left Soft Key  **[Message]** to select:
TXT Message/ Picture Message/ Voice Message

SHORTCUT To view a quick list of all your recent calls, press  from standby mode.

5. View Timers

Allows you to view the duration of selected calls.

1. Press  **[MENU]**.
2. Press  **Recent Calls**.
3. Press  **View Timers**.
4. Use the Directional Key  to highlight a call list.

Last Call/ All Calls/ Received Calls/ Dialed Calls/ Roaming Calls/ Transmit Data/ Received Data/ Total Data/ Last Reset/ Lifetime Calls/ Lifetime Data

5. Press the Left Soft Key  **[Reset]** to reset the highlighted timer.
6. Reset all the recorded timers by pressing the Right Soft Key  **[Reset All]**.

NOTE Lifetime Calls and Lifetime Data cannot be reset.



MY RINGTONES

MEDIA CENTER

MEDIA CENTER allows you to do more than just talk on your phone. MEDIA CENTER is a technology and service that allows you to download and use applications on your phone. With MEDIA CENTER, it's quick and easy to personalize your phone to your lifestyle and tastes. Just download the applications that appeal to you. With a wide range of software available, you can be assured that you can find something useful, practical, or entertaining.

Anything Unclear?

From the MEDIA CENTER menu, press the Right Soft Key  [Info] to see your memory status, activity log, help text, and MEDIA CENTER status. Use the Help option to view information from buying new applications to expired applications.

1. Tunes & Tones

Personalize your phone with ringtones. A wide variety of choices are available, such as current hits, pop, hip-hop, and more.

Access and Options

1. Press  [MENU].
2. Press  **MEDIA CENTER.**
3. Press  **Tunes & Tones.**
4. Select a submenu by pressing the number that corresponds with the submenu.

1.1 Get New Ringtones

Allows you to connect to MEDIA CENTER and download various ringtones.

1. Press  [MENU].
2. Press  **MEDIA CENTER.**
3. Press  **Tunes & Tones.**
4. Press  **Get New Ringtones.**



1.2 My Ringtones

Allows you to select a desired ringtone, or download a new ringtone.

1. Press [MENU].
2. Press **MEDIA CENTER.**
3. Press **Tunes & Tones.**
4. Press **My Ringtones.**
5. Use the Directional Key to highlight a ringtone and press the Left Soft Key [Set As]. You can press [PLAY] to play the ringtone.

- **Ringtone**
- **Contact ID:** Highlight and select the Contact to be identified by the ringtone you selected.
- **Alert Sounds:** Press the corresponding number key to set the ringtone for one of the following:

**All Messages/ TXT Message/
Multimedia Message/ Voicemail**

1.3 My Sounds

Allows you to record a new sound or select a desired sound.

How to record a new sound

1. Press [MENU].
2. Press **MEDIA CENTER.**
3. Press **Tunes & Tones.**
4. Press **My Sounds.**
5. Press **Record New** and press to start recording, then press again to stop.

How to select a sound

1. Press [MENU].
2. Press **MEDIA CENTER.**
3. Press **Tunes & Tones.**
4. Press **My Sounds.**
5. Use the Directional Key to scroll and highlight a preloaded sound.

Options with a sound file highlighted:

- Press the Left Soft Key [Erase].
- Press [PLAY].

- Press the Right Soft Key  [Options] to select:
**Send/ To Online Album/
Rename/ Lock(Unlock)/ Erase
All/ File Info**

2. Pictures

View, take, and trade digital pictures right from your wireless phone.

Access and Options

1. Press  [MENU].
2. Press  **MEDIA CENTER.**
3. Press  **Pictures.**
4. Select a submenu.

2.1 Get New Pictures

Allows you to connect to MEDIA CENTER and download a variety of images for My Pictures.

1. Press  [MENU].
2. Press  **MEDIA CENTER.**
3. Press  **Pictures.**
4. Press  **Get New Pictures.**
5. Press  **Get New Applications.**

2.2 My Pictures

Allows you to view and manage photos stored in the phone.

1. Press  [MENU].
2. Press  **MEDIA CENTER.**
3. Press  **Pictures.**
4. Press  **My Pictures.**
5. Highlight a picture with the Directional Key  and press the Right Soft Key  [Options] for options.
6. Select one of the following options:

Send Picture Message/ To Online Album

Set As Main Wallpaper/ Front Wallpaper/ Picture ID

Take Picture Turns on the camera function.

Get New Pictures Download various pictures.

Manage My Pics Allows you to mark multiple pictures to be erased, moved or locked/ unlocked.

Rename Allows you to change the file name.

Lock (Unlock) Allows you to lock or unlock. Locked files can't be erased accidentally.

File Info Name/ Date/ Time/ Resolution/ Size

* Only appears when the picture is stored on the phone.

Editing a Picture

Access My Pictures, then use the Directional Key  to highlight a picture. Press  **[VIEW]** then press the Right Soft Key  **[Options]** to access additional Edit options like:

Edit Allows you to zoom, rotate and crop the photo.

2.3 Take Picture

Lets you to take digital pictures.

1. Press  **[MENU]**.

2. Press  **MEDIA CENTER.**

3. Press  **Pictures.**

4. Press  **Take Picture.**

5. Set the brightness by pressing the Directional Key up and down , zoom by pressing the Directional Key left and right , and press the Right Soft Key  **[Options]** to change other settings.



NOTE Zooming is not available on the highest resolution.

- Select the option(s) to customize.

RESOLUTION 640x480 / 320x240 / 160x120

SELF TIMER Off/ 3 Seconds/ 5 Seconds/ 10 Seconds

WHITE BALANCE Auto/ Sunny/ Cloudy/ Fluorescent/ Glow

SHUTTER SOUND Shutter/ No Sound /Say "Cheese"/ Ready! 1 2 3

COLOR EFFECTS Normal/
Negative/ Aqua/ Sepia/
Black&White

NIGHT MODE On/ Off

PHOTOMETRY Average/ Spot/
Spot Multiple

PREVIEW Actual view/ Full
screen

6. Take a picture by pressing  **[TAKE]**.
7. Press the Left Soft Key  **[Save]**. The picture is stored in **My Pictures**.

TIP Taking pictures with the flip closed. Press and hold the side camera key on the right side of the phone. And then press the side volume keys on the left side of the phone.

2.4 Online Album

Use to access the Online Album (PIX Place).

1. Press  **[MENU]**.
2. Press  **MEDIA CENTER**.
3. Press  **Pictures**.
4. Press  **Online Album**.
5. Login your mobile number and password, as applicable.

3. Games

Allows you to download games and applications from the MEDIA CENTER server. Choose the software you want from the list displayed on the screen.

1. Press  **[MENU]**.
2. Press  **MEDIA CENTER**.
3. Press  **Games**.
4. Press  **Get New Applications**.



4. Mobile Web

Mobile Web feature allows you to access news, sports, weather and email from your Verizon Wireless device. Access and selections within this feature are dependent upon your service provider. For specific information on Mobile Web through your phone, contact your service provider.

SHORTCUT

Pressing the Directional Key  is the shortcut to accessing Mobile Web 2.0 by default.

1. Press  **[MENU]**.
2. Press  **MEDIA CENTER**.
3. Press  **Mobile Web**.

Ending a Browser Session

End a Browser session by pressing



Navigating Through the Browser

On-screen items appear in one of the following ways:

- **Numbered options**

You can use your numeric keypad or you can select the items by moving the cursor and pressing the appropriate Soft Keys.

- **Links embedded in content**

You can act on the options or the links using the Soft Keys just below the display screen.

- **Text or numbers**

You can select the items by moving the cursor and pressing the appropriate Soft Keys.

Scrolling

Use the Directional Key  .

A cursor lets you know which item is currently selected.

Fast Scrolling

Press and hold the Directional Key  to quickly move the cursor up and down on the current screen.

Scrolling by Page

Press the Side Keys to move up and down a page at a time.

Home Page

Press Right Soft Key  [Menu] and select **1. VZW Home** or press and hold  to go to the Home Page.

View Browser Menu

Press Voice Commands key  to display the Browser menu.

Soft Keys

To navigate to different screens or select special functions, use the Soft Keys. The function associated with the Soft Keys can change for each page and depends on each highlighted item.

Left Soft Key

Left Soft Key  is used primarily for options or selecting an item but its function may change, depending on the content displayed.

Right Soft Key

Right Soft Key  is used primarily for secondary options or a menu of secondary options.

Entering Text, Numbers, or Symbols

When prompted to enter text, the current text entry method appears above the Right Soft Key  as **Word, Abc, ABC, 123** or **Symbols**. To change the input mode, press the Right Soft Key . To create an upper case character, press .

Deleting Text/Number Entered

When entering text or numbers, press  to clear the last number, letter, or symbol. Press and hold  to clear the input field completely.

Initiating a Phone Call From the Browser

You can make a phone call from the Browser if the site you are using supports the feature (the phone number may be highlighted and the Left Soft Key  appears as **Call**). The browser connection is terminated when you initiate the call. After you end the call, your phone returns to the screen from which you initiated the call.



5. Browse & Download

Everything you need to know while you're on the go.

1. Press  **[MENU]**.
2. Press  **MEDIA CENTER.**
3. Press  **Browse & Download.**
4. Press  **Get New Applications** or select **VZ Navigator** using the Directional Key then press .

VZ NavigatorSM

Now you can find the address of a great restaurant or the nearest ATM. Check movie times. Discover the latest hot spots. And know exactly how to get where you're going. VZ Navigator puts all the advanced features of the latest GPS devices and systems on your wireless device — at a fraction of the price.

- NOTES**
- To use VZ Navigator, you must turn location on. (See page 73)
 - Download, subscription and airtime required for use; only in National Enhanced Service Coverage Area: accuracy and completeness of information is not guaranteed; information about location of device will be used to deliver service.

6. Extras

1. Press  **[MENU]**.
2. Press  **MEDIA CENTER.**
3. Press  **Extras.**
4. Press  **Get New Applications.**

MY PICTURES



VZ NAVIGATOR

BLUETOOTH

SETTINGS & TOOLS

1. My Verizon

Check your subscription information ranging from your payment plan to your software upgrade or other available service.

1. Press  **[MENU]**.
2. Press  **Settings & Tools**.
3. Press  **My Verizon**.

2. Tools

Your phone tools include Voice Commands, Calculator, Ez Tip Calculator, Calendar, Alarm Clock, Stopwatch, World Clock, and Notepad.

1. Press  **[MENU]**.
2. Press  **Settings & Tools**.
3. Press  **Tools**.

2.1 Voice Commands

This feature provides you with the following options equipped with AVR (Advanced Voice Recognition) technology. Each option has its detailed information on the phone and you can check it out by pressing the Left Soft Key  **[Info]**.

1. Press  **[MENU]**.
2. Press  **Settings & Tools**.
3. Press  **Tools**.
4. Press  **Voice Commands**.

Access and Options

1. Press the Voice Command Key  (on the left side of the phone).

The Voice Commands feature has several settings which allow you to customize how you want to use it. Access Voice Commands, then press the Right Soft Key  **[Settings]**.

Digit Dial Readout On/ Off

Choice List Automatic/ Always Off

Sensitivity Control the sensitivity as **Reject More/ Automatic/ Reject Less**.

Train Voice If the phone often asks you to repeat voice command, train the phone to recognize your voice patterns.

Train Words/ Train Digits

Prompts Mode/ Audio Playback/ Timeout

For Mode, set **Prompts/ Readout + Alerts/ Readout/ Tones Only**. For Audio Playback, set **Speakerphone or Earpiece**.

For Timeout, set **5 seconds** or **10 seconds**.

Call Alert Ring Only/ Caller ID + Ring/ Name Repeat

2.1.1 Call <Name or Number>

Say "Call" and then call someone simply by saying the name or phone number. Please speak clearly and say the name or number exactly as it is entered in your Contact List. When you have more than one contact number, you can state the name and number type of the contact (for example, 'Call John Work').

2.1.2 Send Msg to <Name or Number>

Say "Send Message" and the command will prompt you for the type of message. After choosing the message type, you will be prompted for the contact name, number or group. It will automatically start a message. If you say a full-sentence command, such as 'Send Message to Bob', it will automatically start a text message without asking for the message type. When using 'Send Message' command, speak clearly and say the name, number or group exactly as it is entered in your Contact List.

2.1.3 Go to <Menu>

The 'Go to' command allows you to access a menu within the phone (for example, 'Go to Calendar'). If no menu option is stated, a list of options will be provided.

2.1.4 Check <Item>

The 'Check' command allows you to check out a wide range of items such as Phone Status, Voicemail, Messages, Missed Calls, Time, Signal Strength, Battery and Volume.



2.1.5 Contacts <Name>

You can look up names in your Contacts (for example, 'Contacts John') as well as manage your Contact List including creating, erasing or modifying.

Read out/ Create New/ Erase/ Modify

2.1.6 My Verizon

The 'My Verizon' command provides you with direct access to your Verizon Wireless account information.

2.1.7 Help

Provides a general guideline to using Voice Commands.

2.2 Calculator

Allows you to perform simple mathematical calculations. You can enter numbers up to eight digits and the sixth decimal place.

Calculations can be made with up to 4 lines at one time.

1. Press  [MENU].
2. Press  **Settings & Tools.**
3. Press  **Tools.**
4. Press  **Calculator.**
5. Enter the numbers to get the

value you want. To cancel a number, press the Left Soft Key  [Clear].

6. Use the Right Soft Key  [Operators] to add parenthesis or power among numbers for calculation.
7. Use the Directional Key  to enter operation between numbers and press  [=] for the result.

NOTE To insert a decimal, press  . To insert ±, press .

2.3 Ez Tip Calculator

Allows you to quickly and easily calculate bill amounts using the bill total, tip % and number of people as variables.

1. Press  [MENU].
2. Press  **Settings & Tools.**
3. Press  **Tools.**
4. Press  **Ez Tip Calculator.**

5. Enter the variable fields (Total bill, Tip (%), Split) and the corresponding calculation fields (tip and total for each person) appear automatically.
6. Press the Left Soft Key  **[Reset]** for another calculation.

2.4 Calendar

Allows you to keep your agenda convenient and easy to access. Simply store your appointments and your phone will alert you with a reminder you set.

SHORTCUT Pressing the Directional Key  downward from standby mode is a hot key to Calendar by default.

1. Press  **[MENU]**.
2. Press  **Settings & Tools**.
3. Press  **Tools**.
4. Press  **Calendar**.
5. Use the Directional Key  to highlight the scheduled day.
Left  : Previous Day
Right  : Next Day
Up  : Previous Week
Down  : Next Week
6. Press the Left Soft Key  **[Add]**.
7. Enter Subject, then scroll down to set remaining settings.
8. Highlight a Calendar setting field, then press the Left Soft Key  **[Set]**. For each Calendar event you can set:
 - Start Date & Time
 - End Date & Time
 - Repeat ● Until
 - Alerts ● Tones
 - Vibrate
9. Use the Directional Key  to highlight the setting you want, then press .
10. Press  **[SAVE]** when Calendar information is complete.



2.5 Alarm Clock

Allows you to set up to three alarms. At the alarm time, Alarm 1 (or 2 or 3) will be displayed on the LCD screen and the alarm will sound.

1. Press **[MENU]**.
2. Press **[9:00]** **Settings & Tools**.
3. Press **[2:abc]** **Tools**.
4. Press **[5:HI]** **Alarm Clock**.
5. Use the Directional Key **[DIRECTIONAL]** to highlight an Alarm (1, 2, or 3), then press **[ENTER]**.
6. Enter the alarm information including:
 - Turn On/Off
 - Set Time
 - Repeat
 - Ringtone
7. Use the Directional Key **[DIRECTIONAL]** to highlight the information you want to set, then press the Left Soft Key **[LEFT]** **[Set]** to view your setting choices.
8. Press **[ENTER]** **[SAVE]** after setting all of the Alarm fields as necessary.

NOTE You can also open the flip and choose Snooze or Dismiss.

2.6 Stopwatch

Allows you to use your phone as a typical stopwatch. Pressing **[ENTER]** will start and stop Stopwatch time. While measuring time, press the Left Soft Key **[LEFT]** to lap. After time has stopped, press the Right Soft Key **[RIGHT]** **[Reset]**.

1. Press **[MENU]**.
2. Press **[9:00]** **Settings & Tools**.
3. Press **[2:abc]** **Tools**.
4. Press **[6:MIN]** **Stopwatch**.

2.7 World Clock

Allows you to determine the current time in another time zone or country by navigating with the Directional Key to the right or left.

1. Press **[MENU]**.
2. Press **[9:00]** **Settings & Tools**.
3. Press **[2:abc]** **Tools**.
4. Press **[7:WORLD]** **World Clock**.
5. Press the Right Soft Key **[RIGHT]** **[Cities]** for a list of available cities.

6. Select a city from the list, then press .
The display shows the position of the city on a global map.
7. Press again to zoom in on the city and view its date and time information.

NOTE With the Left Soft Key [Set DST], set to daylight saving time.

2.8 Notepad

Allows you to add, read, edit, and erase notes to yourself.

1. Press [MENU].
2. Press **Settings & Tools**.
3. Press **Tools**.
4. Press **Notepad**.
5. Press the Left Soft Key [Add] to write a new note.
6. Press the Left Soft Key to change the entry mode.
7. After filling in the note, press to save it.

2.9 USB Mass Storage

1. Press [MENU].
2. Press **Settings & Tools**.
3. Press **Tools**.

4. Press **USB Mass Storage**.
5. Press the Left Soft Key [Add] to write a new note.
6. Press the Left Soft Key to change the entry mode.
7. After filling in the note, press to save it.

3. Bluetooth® Menu

The VX7100 is compatible with devices that support the Headset, Handsfree, Phonebook Access and Object Push for vCard & vCal. You may create and store 20 pairings within the VX7100 and connect to one device.

The approximate communication range for Bluetooth® wireless technology is up to 30 feet (10 meters).

Bluetooth® QD ID B014472

NOTE Read the user guide of each Bluetooth® accessory that you are trying to pair with your phone because the instructions may be different.

NOTE Your phone is based on the Bluetooth® specification, but it is not guaranteed to work with all devices enabled with Bluetooth® wireless technology. Phone does not support ALL Bluetooth® OBEX Profiles.

* For vehicle/accessory compatibility go to www.verizonwireless.com/bluetoothchart.



- TIPS**
- **HEADSET:** Supports use of a compatible bluetooth® headset for mono voice.
 - **HANDSFREE:** Supports Bluetooth® headsets, and may also support other installed compatible Bluetooth® devices with speakerphone capabilities, such as car kits or a conference room device. For Handsfree Car Kit Compatibility, refer to www.verizonwireless.com/bluetoothchart on the Verizon Wireless website.
 - **PHONEBOOK ACCESS:** Allows sharing of your name card, phonebook entries, and call history with a compatible Bluetooth® device.
 - **OBJECT PUSH:** Allows sending and receiving of contact name cards and calendar events.

3.1 Add New Device

Pairing is the process that allows the handset to locate, establish, and register 1-to-1 connection with the target device.

3.1.1 For pairing with a new Bluetooth® device

1. Follow the Bluetooth® accessory instructions to set the device to pairing mode.
2. Press  **[MENU]**.
3. Press  **Settings & Tools**.
4. Press  **Bluetooth Menu**.
5. Press  **Add New Device**.
Set the desired device to pairing.
6. If Bluetooth® power is set to off, you will be prompted to turn power on. Highlight **Yes** and press .
7. The device will appear in Add New Device menu once it has been located. Highlight the device and press .
8. The handset will prompt you for the passcode. Consult the Bluetooth® accessory instructions for the appropriate passcode (typically “0000” - 4 zeroes). Enter the passcode and press . When Auto Pair Handsfree is set to On, the device will try to autopair for headset.
9. When pairing with the Computer, PC or PDA is successful, highlight either **Always Ask** or **Always Connect** and press  to connect with the device.
10. Once connected, you will see the device listed in the Bluetooth® Menu and Bluetooth® indicator will change to the  will show up on your screen when connected to the

Bluetooth® device. You can also check out the connection with a blue icon  on the list.

3.1.2 Icon Reference in Adding New Device

When the Bluetooth® wireless connection is built and paired devices are found, the following icons are displayed.

- **Icon References When a Bluetooth® Wireless Connection is Searched** (neither connected nor paired).

	When a carkit device is found by your VX7100 device
	When an audio device is found by your VX7100 device
	When a PC is found by your VX7100 device
	When a PDA is found by your VX7100 device
	When another phone device is found by your VX7100 device
	When a printer is found by your VX7100 device
	When other undefined devices are found by your VX7100 device

- **Icon References When Successfully Connected**

	When an only mono headset is connected with your VX7100 device
---	--

Turn On

Allows you to set the phone's Bluetooth® power On/Off.

1. Press  **[MENU]**.
2. Press  **Settings & Tools.**
3. Press  **Bluetooth Menu.**
4. Press the Left Soft Key  **[Turn On]**.

NOTE By default, your device's Bluetooth® functionality is turned off.



My Device Info

Allows you to edit the name of the Bluetooth® device when Add New Device menu is highlighted.

1. Press  [MENU].
2. Press  **Settings & Tools.**
3. Press  **Bluetooth Menu.**
4. Press the Right Soft Key  [Options].
5. Press  **My Device Info.**
6. Press  to clear the existing name.
7. Use the Alphanumeric Keypad to enter a new custom name.
8. Press  to save and exit.

Discovery Mode

Allows you to set whether your device is able to be searched by other *Bluetooth* devices in the area.

1. Press  [MENU].
2. Press  **Settings & Tools.**
3. Press  **Bluetooth Menu.**
4. Press the Right Soft Key  [Options].
5. Press  **Discovery Mode.**
6. Use the Directional Key  to highlight a setting, then press .

On / Off

NOTE If you choose **On** for Discovery Mode, your device is able to be searched by other in-range Bluetooth® devices.

Supported Profiles

Allows you to see profiles that your VX7100 phone can support.

1. Press  [MENU].
2. Press  **Settings & Tools.**
3. Press  **Bluetooth Menu.**
4. Press the Right Soft Key  [Options].
5. Press  **Supported Profiles.**

Auto Pair Handsfree

Allows Bluetooth pairing with an audio device to be tried automatically with a default PIN code- 0000.

1. Press  [MENU].
2. Press  **Settings & Tools.**
3. Press  **Bluetooth Menu.**
4. Press the Right Soft Key  [Options].
5. Press  **Auto Pair Handsfree.**

On / Off

The following options are available in the paired device.

For headset devices:

1. **Remove Device:** You can remove the device from the pairing list.
2. **Rename Device:** You can rename the paired device.
3. **Incoming Security:** Allows you to set permission before connecting an incoming device.
4. **Service Discovery:** Allows you to search for the services that the selected device supports.
5. **Device Info:** Shows the device information.

NOTE When the device is connected to



another handset the following extra options where found:

**Send Name Card/ Get Name Card/
Exchange Name Card/ Send
Calendar Event**

NOTES

In the pairing list, you can disconnect the connected device with the Left Soft Key  **[Turn Off]**. Reverse, you can turn it on by pressing the Left Soft Key  **[Turn On]** again.

When an audio device is connected, then you select another device and press  , both devices are connected.

When connected with Phone or PC supporting OPP, the following menus are possible:

- **Send name card:** Allows my contact data to send other device up to 1000 Contacts.
- **Get name card:** Allows you to pull name card of other device.
- **Exchange name card:** Allows you to exchange my name card with other device. **Send Calendar Event:** Allows you to send up to 300 Calendar events to other device.

4. Sounds Settings

Provides options to customize the phone's sounds.

4.1 Easy Set-up

Allows you to set volume settings.

1. Press  **[MENU]**.
2. Press  **Settings & Tools.**
3. Press  **Sounds Settings.**
4. Press  **Easy Set-up.**

4.2 Master Volume

Allows you to set volume settings.

1. Press  **[MENU]**.
2. Press  **Settings & Tools.**
3. Press  **Sounds Settings.**
4. Press  **Master Volume.**
5. Adjust the volume with the Directional Key  then press  to save the setting.

4.3 Call Sounds

Allows you to set how the phone alerts you for types of incoming calls.

1. Press  **[MENU]**.
2. Press  **Settings & Tools.**

3. Press  **Sounds Settings.**

4. Press  **Call Sounds.**

4.3.1 Call Ringtone

1. Press  **[MENU].**
2. Press  **Settings & Tools.**
3. Press  **Sounds Settings.**
4. Press  **Call Sounds.**
5. Press  **Call Ringtone.**
6. Use the Directional Key  to highlight a ringtone then press  to save the sound.

TIP To hear a ringtone before you set it, press the Left Soft Key  **[Play].**

4.3.2 Call Vibrate

1. Press  **[MENU].**
2. Press  **Settings & Tools.**
3. Press  **Sounds Settings.**
4. Press  **Call Sounds.**
5. Press  **Call Vibrate.**
6. Use the Directional Key  to highlight a setting, then press .

On/ Off

4.4 Alert Sounds

Allows you to select the alert type for a new message.

1. Press  **[MENU].**
2. Press  **Settings & Tools.**
3. Press  **Sounds Settings.**
4. Press  **Alert Sounds.**
5. Select **TXT Message/ Multimedia Message/ Voicemail/Emergency Tone**
6. The Alert Sounds menu has these options:
Tone/ Vibrate/ Reminder
The exception for this is the Emergency Tone menu. This menu has these options:
Alert/ Vibrate/ Off



4.5 Keypad Volume

Allows you to set the keypad volume.

1. Press  [MENU].
2. Press  **Settings & Tools.**
3. Press  **Sounds Settings.**
4. Press  **Keypad Volume.**
5. Adjust the volume with the Directional Key  then press  to save the setting.

4.6 Digit Dial Readout

1. Press  [MENU].
2. Press  **Settings & Tools.**
3. Press  **Sounds Settings.**
4. Press  **Digit Dial Readout.**

4.7 Service Alerts

Allows you to set any of the four Alert options to either On or Off.

1. Press  [MENU].
2. Press  **Settings & Tools.**
3. Press  **Sounds Settings.**
4. Press  **Service Alerts.**

5. Select an alert option.

ERI Alerts you to the status of cellular service.

ERI: Enhanced Roaming Indicator

Minute Beep Alerts you 10 seconds before the end of every minute during a call.

Call Connect Alerts you when the call is connected.

Charge Complete Alerts you when the battery is completely charged.

6. Use the Directional Key  to highlight a setting, then press  .
On/ Off

4.8 Power On/Off

Allows you to set the phone to sound a tone when the phone is powered on/off.

1. Press  [MENU].
2. Press  **Settings & Tools.**
3. Press  **Sounds Settings.**
4. Press  **Power On/Off.**
5. Select **Power On/ Power Off.**
6. Use the Directional Key  to highlight a setting, then press  .
On/ Off

4.9 Voice Clarity

Allows you to set the phone to automatically adapt to noisy environments by adjusting the listening level and improving speech intelligibility.

NOTE The Voice Clarity feature is automatically disabled when you use the speakerphone or the hands-free devices.

1. Press  [MENU].
2. Press  **Settings & Tools.**
3. Press  **Sounds Settings.**
4. Press  **Voice Clarity.**
5. Use the Directional Key  to scroll to a setting, then press .

On/ Off

5. Display Settings

Provides options to customize the phone's display screen.

1. Press  [MENU].
2. Press  **Settings & Tools.**
3. Press  **Display Settings.**

5.1 Easy Set-up

Allows you to set volume settings.

1. Press  [MENU].
2. Press  **Settings & Tools.**
3. Press  **Display Settings.**
4. Press  **Easy Set-up.**

5.2 Banner

Allows you to enter a string of up to 23 characters which displays on the LCD screen.

1. Press  [MENU].
2. Use the Directional Key  to scroll to **SETTINGS & TOOLS**, then press .
3. Press  **Display Settings.**
4. Press  **Banner.**

5.2.1 Personal Banner

1. Press **[MENU]**.
2. Press **9** **Settings & Tools**.
3. Press **5** **Display Settings**.
4. Press **2** **Banner**.
5. Press **1** **Personal Banner**.
6. Enter your own banner text.

NOTE Press the Directional Key **[Up]** to change the color of the text. Use the **[Down]** to select the color you want. Black/ White/ Yellow/ Orange/ Red/ Brown/ Blue/ Green/ Sky Blue

7. Press **[Enter]**.

5.2.2 ERI Banner

If you use ERI Service, ERI Text is shown on the sub banner.

1. Press **[MENU]**.
2. Press **9** **Settings & Tools**.
3. Press **5** **Display Settings**.
4. Press **2** **Banner**.
5. Press **2** **ERI Banner**.
6. Use the Directional Key **[Up]** to highlight a setting, then press **[Enter]**.

On/ Off

5.3 Backlight

Allows you to set the duration for illuminating the backlight. Display and Keypad are set separately.

1. Press **[MENU]**.
2. Press **9** **Settings & Tools**.
3. Press **5** **Display Settings**.
4. Press **3** **Backlight**.
5. Highlight a Backlight submenu and press **[Enter]**.

Display/ Keypad

1. Display

Main Backlight: 7 Seconds/
15 Seconds/ 30 Seconds/
Always On/ Always Off

Front Backlight: 7 Seconds/
15 Seconds/ 30 Seconds

2. **Keypad:** 7 Seconds/ 15 Seconds/ 30 Seconds/
Always On/ Always Off

5.4 Wallpaper

Allows you to choose the kind of background to be displayed on the phone's LCD in standby mode.

1. Press  **[MENU]**.
2. Press  **Settings & Tools**.
3. Press  **Display Settings**.
4. Press  **Wallpaper**.
5. Highlight a Wallpaper submenu and press .

Main Wallpaper/ Front Wallpaper

1. **Main Wallpaper**
My Pictures/ Fun Animations
2. **Front Wallpaper**
Highlight the desired picture and press  to select.
6. Zoom in or out is available by Soft Keys and press  to set.

5.5 Display Themes

Allows you to choose the color of the background screen.

1. Press  **[MENU]**.
2. Press  **Settings & Tools**.
3. Press  **Display Settings**.
4. Press  **Display Themes**.
5. Use the Directional Key  to highlight a setting, then press .

Classic/Urban/Black

NOTE Press the Left Soft Key  **[Preview]** to preview the selected display theme.

5.6 Main Menu Settings

Allows you to choose how the Main Menu displays for menu selection.

1. Press  **[MENU]**.
2. Press  **Settings & Tools**.
3. Press  **Display Settings**.
4. Press  **Main Menu Settings**.



5. Use the Directional Key  to highlight a setting, then press .

Tab/ List/ Grid

NOTE This User Guide gives navigation instructions according to the default "List" Main Menu Layout in the Display Settings menu. If other menus are set, navigating the phone's menus may be different.

NOTE Press the Left Soft Key  [**Preview**] to preview the selected menu setting.

5.7 Font Size

Allows you to set the Dial Digits font size, Menu & Lists font size, and Message font size. This setting is helpful for those who need the text to display a little bit larger.

1. Press  [**MENU**].
2. Press  **Settings & Tools**.
3. Press  **Display Settings**.
4. Press  **Font Size**.
5. Use the Directional Key  to select **Dial Digits/ Menu & Lists/ Message**.
6. Press the Left Soft Key  [**Set**].

7. Use the Directional Key  to highlight a setting, then press

Dial Digits: **Normal/Large**
Menu & Lists: **Normal/ Large**
Message: **Normal/ Large**

5.8 Menu Fonts

Allows you to set the font type.

1. Press  [**MENU**].
 2. Press  **Settings & Tools**.
 3. Press  **Display Settings**.
 4. Press  **Menu Fonts**.
 5. Use the Directional Key  to scroll to a setting, then press .
- VZW Font/ LG Edge/ LG Script**

NOTE The selected font can be previewed at the bottom left side of the LCD

5.9 Clock Format

Allows you to choose the kind of clock to be displayed on the front and main LCD screens.

1. Press  **[MENU]**.
2. Press  **Settings & Tools**.
3. Press  **Display Settings**.
4. Press  **Clock Format**.
5. Highlight a Clock Format submenu and press .

Main Clock/ Front Clock

1. Main Clock

Normal/ Analog/ Digital 12/
Large Digital 12/ Digital 24/
Large Digital 24/ Dual / Off

2. Front Clock

Digital 12/ Large Digital 12/ Off

6. Use the Directional Key  to highlight a setting, then press .

NOTE Press the Left Soft Key 

[Preview] to preview the selected clock format.

6. Phone Settings

The Phone Settings Menu allows you to designate specific settings to customize how you use your phone.

6.1 Airplane Mode

Turning on Airplane Mode will disable all wireless communications.

1. Press  **[MENU]**.
2. Press  **Settings & Tools**.
3. Press  **Phone Settings**.
4. Press  **Airplane Mode**.
5. Use the Directional Key  to highlight a setting, then press .

On/ Off



6.2 Set Shortcuts

Allows you to set shortcuts to phone menus using the down, up, left and right Directional Key.

6.2.1 Set My Shortcuts

To access these shortcuts open the flip, then press the Directional Key to the right from standby mode (by default) to display your four shortcuts.

1. Press **[MENU]**.
2. Press **Settings & Tools**.
3. Press **Phone Settings**.
4. Press **Set Shortcuts**.
5. Press **Set My Shortcuts**.
6. Use the Directional Key to highlight a shortcut key you want to set.

Shortcut 1/ Shortcut 2/ Shortcut 3/ Shortcut 4

7. Press to display the available shortcuts. Use the Directional Key to select one, then press .

6.2.2 Set Directional Keys

To access these shortcuts open the flip, then press the Directional Key to access the option that you configured for that specific directional key.

1. Press **[MENU]**.
2. Press **Settings & Tools**.
3. Press **Phone Settings**.
4. Press **Set Shortcuts**.
5. Press **Set Directional Keys**.
6. Use the Directional Key to highlight a shortcut key you want to set.

Up Directional Key/ Left Directional Key/ Down Directional Key

7. Press to display the available shortcuts. Use the Directional Key to select one, then press .

6.3 Voice Commands

Using the Internal Keypad

1. Press  [MENU].
2. Press  **Settings & Tools.**
3. Press  **Phone Settings.**
4. Press  **Voice Commands.**

Prompts Mode/ Audio

Playback/ Timeout

For Mode, set **Prompts/ Readout + Alerts/ Readout/ Tones Only.**

For Audio Playback, set **Speakerphone/ Earpiece.** For Timeout, set **5 seconds** or **10 seconds.**

Call Alert Ring Only/ Caller ID + Ring/ Name Repeat

6.4 Language

Allows you to set the bilingual (English or Spanish) feature according to your preference.

1. Press  [MENU].
2. Press  **Settings & Tools.**
3. Press  **Phone Settings.**
4. Press  **Language.**
5. Use the Directional Key  to highlight a setting, then press .

English/ Español

6.5 Location

Allows you to set GPS (Global Positioning System: Satellite assisted location information system) mode.

1. Press  [MENU].
2. Press  **Settings & Tools.**
3. Press  **Phone Settings.**
4. Press  **Location.**
5. Use the Directional Key  to highlight a setting, then press .

Location On/ E911 Only



- NOTES**
- GPS satellite signals are not always received by the phone, especially under bad atmospheric and environmental conditions, indoors, etc.
 - When a Location Setting Restriction is activated in the Security Menu, the lock code is required when you enter location menu. The lock code is the same 4 digits you use as your device lock code; initially the last 4 digits of your phone number.
 - When in Airplane Mode, services supporting Location On functionality (such as Chaperone) will be suspended.

6.6 Current Country

The Current Country menu allow to select your current location.

1. Press [MENU].
2. Press **Settings & Tools.**
3. Press **Phone Settings.**
4. Press **Current Country.**
5. Use the Directional Key to highlight a setting, then press .

NOTE To assure that your phone works properly while you travel, please verify the country of your current location, so the correct Country Code can be applied.

6.7 Security

The Security menu allows you to secure the phone electronically.

1. Press [MENU].
2. Press **Settings & Tools.**
3. Press **Phone Settings.**
4. Press **Security.**
5. Enter the four-digit lock code.
The lock code is the last 4 digits of your mobile phone number if it is set.

The lock code is the last 4 digits of your MEID if your mobile phone number is not set.

6.7.1 Edit Codes

Allows you to enter a new four-digit lock code.

1. Press [MENU].
2. Press **Settings & Tools.**
3. Press **Phone Settings.**
4. Press **Security.**
5. Enter the four-digit lock code.
6. Press **Edit Codes.**
7. Select **Phone Only** or **Calls & Services.**
8. Enter your new four-digit lock

code.

9. For confirmation, it will ask you to enter the new lock code again.

6.7.2 Restrictions

Allows you to set separate restrictions for Location Setting, Calls and Messages.

1. Press  [MENU].
2. Press  **Settings & Tools.**
3. Press  **Phone Settings.**
4. Press  **Security.**
5. Enter the four-digit lock code.
6. Press  **Restrictions.**
7. Enter the four-digit PIN code.
8. Select a Restrictions menu then press .

**Location Setting/ Calls/
Messages**

9. Use the Directional Key  to highlight the restriction then press .

Location Setting Lock Setting/
Unlock Setting

Calls: Incoming Calls Allow
All / Contacts Only / Block All

Calls: Outgoing Calls Allow All
/ Contacts Only / Block All

**Messages: Incoming
Messages** Allow All / Block
All

**Messages: Outgoing
Messages** Allow All / Block
All

6.7.3 Phone Lock

Keeps your phone from unauthorized use. Once the phone is locked, it's in restricted mode until the lock code is entered. You can still receive phone calls and make emergency calls. You can modify the lock code using Edit Codes submenu within the Security menu.

1. Press  [MENU].
2. Press  **Settings & Tools.**
3. Press  **Phone Settings.**
4. Press  **Security.**



5. Enter the four-digit lock code.
6. Press **3** **Phone Lock**.
7. Highlight an option then press **⊙**.

Unlocked The phone is never locked (Lock mode can still be used).

On Power Up The phone is locked when it is turned on.

6.7.4 Lock Phone Now

1. Press **⊙** **[MENU]**.
2. Press **9** **Settings & Tools**.
3. Press **6** **Phone Settings**.
4. Press **7** **Security**.
5. Enter the four-digit lock code.
6. Press **4** **Lock Phone Now**.

6.7.5 Reset Default

Allows you to reset your phone to the factory default settings.

1. Press **⊙** **[MENU]**.
2. Press **9** **Settings & Tools**.
3. Press **6** **Phone Settings**.
4. Press **7** **Security**.
5. Enter the four-digit lock code.
6. Press **5** **Reset Default**.

7. Press **⊙** after reading the warning message.
8. Select **Revert** by pressing **⊙**.

A confirmation message is displayed briefly before the phone resets itself.

6.7.6 Restore Phone

Allows you to erase all user data and Contact information you've entered in the phone's memory so it's as if it just left the factory.

1. Press **⊙** **[MENU]**.
2. Press **9** **Settings & Tools**.
3. Press **6** **Phone Settings**.
4. Press **7** **Security**.
5. Enter the four-digit lock code.
6. Press **6** **Restore Phone**.
7. Press **⊙** after reading the warning message.
8. Enter the four-digit lock code.

6.8 System Select

Allows you to set up the phone management environment. Leave this setting as the default unless you want to alter system selection as instructed by your service provider.

1. Press  [MENU].
2. Press  **Settings & Tools.**
3. Press  **Phone Settings.**
4. Press  **System Select.**
5. Use the Directional Key  to highlight a setting, then press .

Home Only/ Automatic

6.9 NAM Select

Allows you to select the phone's NAM (Number Assignment Module) if the phone is registered with multiple service providers.

1. Press  [MENU].
2. Press  **Settings & Tools.**
3. Press  **Phone Settings.**
4. Press  **NAM Select.**
5. Use the Directional Key  to highlight a setting, then press .

NAM1/ NAM2

6.0 CDG2

1. Press  [MENU].
2. Press  **Settings & Tools.**
3. Press  **Phone Settings.**
4. Press  **CDG2.**

7. Call Settings

The Call Settings Menu allows you to designate how the phone handles both incoming and outgoing calls.

7.1 Answer Options

Allows you to determine how the phone will answer an incoming call.

1. Press  [MENU].
2. Press  **Settings & Tools.**
3. Press  **Call Settings.**
4. Press  **Answer Options.**
5. Use the Directional Key  to mark the setting(s) you want to use, then press .

Flip Open/ Any Key/ Auto with Handsfree



6. Press the Left Soft Key  **[Done]** when you have marked the setting(s) you want.

NOTE Auto with Handsfree is available when any external device is connected to your phone or speaker is set to on.

When the following settings are set, Ringer is not activated.

- When **Sounds Off / Alarm Only** is set or individual Contact Ringer ID is set to **No Ring/ Silence**.
- When Ringer is set to **Sounds Off** with side key or "Quiet".

7.2 Auto Retry

Allows you to set the length of time the phone waits before automatically redialing a number when the attempted call fails.

1. Press  **[MENU]**.
2. Press  **Settings & Tools**.
3. Press  **Call Settings**.
4. Press  **Auto Retry**.
5. Use the Directional Key  to highlight a setting, then press .

Off/ Every 10 Seconds/ Every 30 Seconds/ Every 60 Seconds

7.3 TTY Mode

Allows you to attach a TTY device enabling you to communicate with parties also using a TTY device. A phone with TTY support is able to translate typed characters to voice. Voice can also be translated into characters and then displayed on the TTY.

1. Press  **[MENU]**.
2. Press  **Settings & Tools**.
3. Press  **Call Settings**.
4. Press  **TTY Mode**.

An explanation message is displayed.

5. Press  to continue.
6. Use the Directional Key  to highlight a setting, then press .
TTY Full/ TTY + Talk/ TTY + Hear/ TTY Off

TTY Full: Users who cannot talk or hear send and receive a text message through TTY equipment.

TTY + Talk: Users who can talk but cannot hear receive a text message and send voice through TTY equipment.

TTY + Hear: Users who can hear but cannot talk send a text message and receive voice through TTY equipment.

TTY Off: Users send and receive without TTY equipment.

Connecting TTY Equipment and a Terminal

1. Connect a TTY cable to TTY connection on the terminal (TTY connection location is the same as a headset jack).
2. Enter the phone menu and set the desired TTY mode.
3. After setting a TTY mode, check the LCD screen of the phone for the TTY icon.
4. Connect the TTY equipment to the power source and turn it on.
5. Make a phone connection to the desired number.
6. When connection is made, use the TTY equipment to type in and send a text message or send voice.

TTY Mode (Tele Type writer)

Menu	User	Feature	Transmission/ Receiving Mode	When making communications with a normal terminal
TTY Full	For hearing-/ verbally- impaired		text message transmission, text message receiving	Operator required
TTY + Talk	For hearing- impaired	able to talk	voice transmission, text message receiving	Operator required
TTY + Hear	For verbally- impaired	audible	text message transmission, voice receiving	Operator required
TTY Off			voice transmission, voice receiving	



7. The voice or text message from the receiver end displays on the TTY equipment display.

7.4 One Touch Dial

Allows you to initiate a speed dial call by pressing and holding the speed dial digit. If set to Off, Speed Dial numbers designated in your Contacts will not function.

1. Press  **[MENU]**.
2. Press  **Settings & Tools**.
3. Press  **Call Settings**.
4. Press  **One Touch Dial**.
5. Use the Directional Key  to highlight a setting, then press .

On/ Off

7.5 Voice Privacy

Allows you to set the voice privacy feature for CDMA calls. CDMA offers inherent voice privacy. Check with your service provider for availability.

1. Press  **[MENU]**.
2. Press  **Settings & Tools**.
3. Press  **Call Settings**.
4. Press  **Voice Privacy**.
5. Use the Directional Key  to

highlight a setting, then press .

On/ Off

7.6 DTMF Tones

Allows you to set the DTMF tone length.

1. Press  **[MENU]**.
2. Press  **Settings & Tools**.
3. Press  **Call Settings**.
4. Press  **DTMF Tones**.
5. Use the Directional Key  to highlight a setting, then press .

Short/ Long

7.7 Assisted Dialing

Allows you to allows easy dialing of international calls while roaming in another country. If Set to On, Assisted Dialing is displayed in calling screen.

1. Press  **[MENU]**.
2. Press  **Settings & Tools**.
3. Press  **Call Settings**.
4. Press  **Assisted Dialing**.

5. Use the Directional Key  to highlight a setting, then press .

On/ Off

6. Highlight the Reference Country and press Left Soft Key  **Set** to select country.
7. Use the Directional Key  to scroll to the desired country.
8. Press Left Soft Key  **Details** to edit and save the country code, IDD Prefix(International Direct Dial), NDD Prefix(National Direct Dial), Area/City Code and Length(Length of Phone Number), then press  to set.

NOTE Ex.> A device in a China is trying to reach a U.S. number, 201-555-5555 (Reference Country is U.S.A.)
replace '+' code with IDD prefix for China.
User Enters: +1-201-555-5555 ,
Assisted Dialing : 00-1-201-555-5555

8. Memory

Allows you to check your VX7100 internal phone memory.

Shows the memory information saved in your phone.

1. Press  **[MENU]**.
2. Press  **Settings & Tools**.
3. Press  **Memory**.
4. Use the Directional Key  to select file storage type in the VX7100, then press  to view the memory used.

Memory Usage / My Pictures / My Sounds

9. Phone Info

Allows you to view the information specific to your phone and software.

1. Press  **[MENU]**.
2. Press  **Settings & Tools**.
3. Press  **Phone Info**.



9.1 My Number

Allows you to view your phone number.

1. Press  **[MENU]**.
2. Press  **Settings & Tools**.
3. Press  **Phone Info**.
4. Press  **My Number**.

9.2 SW/HW Version

Allows you to view the versions of various applications such as SW, PRL, ERI, Browser, Media Center, AVR, MMS, Bluetooth®, OTADM Version, MSUI, HW, MEID Version, and Warranty Date Code.

1. Press  **[MENU]**.
2. Press  **Settings & Tools**.
3. Press  **Phone Info**.
4. Press  **SW/HW Version**.

9.3 Icon Glossary

Allows you to view all the icons and their meanings.

1. Press  **[MENU]**.
2. Press  **Settings & Tools**.
3. Press  **Phone Info**.
4. Press  **Icon Glossary**.

9.4 Software Update

This feature gives your phone the ability to upgrade to the latest software and keeps your phone operating with the latest features without visiting a Verizon Wireless Communications Store for the upgrade. You can either be notified automatically that there is an updated version of software available for your phone, or you can manually check to see if there are any updates available for you to download.

Automatic Update

Your phone will receive a notification that there is an updated version of software available to be downloaded. You can press  when notified that a download is available or it can happen automatically. Once the download is complete you may, depending on the nature of the update, have three options available: Accept the update, Defer the update, or Reject the update.

NOTE During the update you cannot make or receive phone calls, including 911 calls, or text messages.

Manual Update

1. Press  [MENU].
2. Press  **Settings & Tools.**
3. Press  **Phone Info.**
4. Press  **Software Update.**

The two options shown will be **Status** and **Check New**.

Press  **Status** to see the status of a download or update and see information on the last successful update. If updates have not yet been performed, status information will be unavailable.

Press  **Check New** to check if any new software updates are available to download. If a newer software version is available, it will automatically begin downloading after 30 seconds or you can begin the download immediately by pressing . To stop the software download press the Right Soft Key  [Quit].



TIA Safety Information

The following is the complete TIA Safety Information for wireless handheld phones.

Exposure to Radio Frequency Signal

Your wireless handheld portable phone is a low power radio transmitter and receiver. When ON, it receives and sends out Radio Frequency (RF) signals.

In August, 1996, the Federal Communications Commissions (FCC) adopted RF exposure guidelines with safety levels for handheld wireless phones. Those guidelines are consistent with the safety standards previously set by both U.S. and international standards bodies:

ANSI C95.1 (1992) *

NCRP Report 86 (1986)

ICNIRP (1996)

* American National Standards Institute; National Council on Radiation Protection and Measurements; International Commission on Non-Ionizing Radiation Protection

Those standards were based on comprehensive and periodic evaluations of the relevant scientific literature. For example, over 120 scientists, engineers, and physicians from universities, government health agencies, and industry reviewed the available body of research to develop the ANSI Standard (C95.1).

The design of your phone complies with the FCC guidelines (and those standards).

Antenna Care

Use only the supplied or an approved replacement antenna. Unauthorized antennas, modifications, or attachments could damage the phone and may violate FCC regulations.

Phone Operation

NORMAL POSITION: Hold the phone as you would any other telephone with the antenna pointed up and over your shoulder.

Tips on Efficient Operation

For your phone to operate most efficiently:

Don't touch the antenna unnecessarily when the phone is in use. Contact with the antenna affects call quality and may cause the phone to operate at a higher power level than otherwise needed.

Driving

Check the laws and regulations on the use of wireless phones in the areas where you drive and always obey them. Also, if using your phone while driving, please observe the following:

- Give full attention to driving -- driving safely is your first responsibility;
- Use hands-free operation, if available;
- Pull off the road and park before making or answering a call if driving conditions or the law require it.

Electronic Devices

Most modern electronic equipment is shielded from RF signals. However, certain electronic equipment may not be shielded

against the RF signals from your wireless phone.

Pacemakers

The Health Industry Manufacturers Association recommends that a minimum separation of six (6) inches be maintained between a handheld wireless phone and a pacemaker to avoid potential interference with the pacemaker. These recommendations are consistent with the independent research by and recommendations of Wireless Technology Research.

Persons with pacemakers:

- Should ALWAYS keep the phone more than six (6) inches from their pacemaker when the phone is turned ON;
- Should not carry the phone in a breast pocket;
- Should use the ear opposite the pacemaker to minimize the potential for interference;
- Should turn the phone OFF immediately if there is any reason to suspect that interference is taking place.



Hearing Aids

Some digital wireless phones may interfere with some hearing aids. In the event of such interference, you may want to consult your service provider (or call the customer service line to discuss alternatives).

Other Medical Devices

If you use any other personal medical device, consult the manufacturer of your device to determine if it is adequately shielded from external RF energy. Your physician may be able to assist you in obtaining this information.

Health Care Facilities

Turn your phone OFF in health care facilities when any regulations posted in these areas instruct you to do so. Hospitals or health care facilities may use equipment that could be sensitive to external RF energy.

Vehicles

RF signals may affect improperly installed or inadequately shielded electronic systems in motor vehicles. Check with the manufacturer or its representative

regarding your vehicle. You should also consult the manufacturer of any equipment that has been added to your vehicle.

Posted Facilities

Turn your phone OFF in any facility where posted notices so require.

Aircraft

FCC regulations prohibit using your phone while in the air. Switch OFF your phone before boarding an aircraft.

Blasting Areas

To avoid interfering with blasting operations, turn your phone OFF when in a “blasting area” or in areas posted: “Turn off two-way radio”. Obey all signs and instructions.

Potentially Explosive Atmosphere

Turn your phone OFF when in any area with a potentially explosive atmosphere and obey all signs and instructions. Sparks in such areas could cause an explosion or fire resulting in bodily injury or even death.

Areas with a potentially explosive atmosphere are often, but not

always marked clearly. Potential areas may include: fueling areas (such as gasoline stations); below deck on boats; fuel or chemical transfer or storage facilities; vehicles using liquefied petroleum gas (such as propane or butane); areas where the air contains chemicals or particles (such as grain, dust, or metal powders); and any other area where you would normally be advised to turn off your vehicle engine.

For Vehicles Equipped with an Air Bag

An air bag inflates with great force. DO NOT place objects, including either installed or portable wireless equipment, in the area over the air bag or in the air bag deployment area. If in-vehicle wireless equipment is improperly installed and the air bag inflates, serious injury could result.

Safety Information

Please read and observe the following information for safe and proper use of your phone and to prevent damage. Also, keep the user guide in an accessible place at all times after reading it.

 **Caution** Violation of the instructions may cause minor or serious damage to the product.

- Do not disassemble or open, crush, bend or deform, puncture or shred.
- Do not modify or remanufacture, attempt to insert foreign objects into the battery, immerse or expose to water or other liquids, expose to fire, explosion or other hazard.
- Only use the battery for the system for which it is specified.
- Only use the battery with a charging system that has been qualified with the system per IEEE-Std-1725-2006. Use of an unqualified battery or charger may present a risk of fire, explosion, leakage, or other hazard.



- Do not short circuit a battery or allow metallic conductive objects to contact battery terminals.
- Replace the battery only with another battery that has been qualified with the system per this standard, IEEE-Std-1725-2006. Use of an unqualified battery may present a risk of fire, explosion, leakage or other hazard.
- Promptly dispose of used batteries in accordance with local regulations.
- Battery usage by children should be supervised.
- Avoid dropping the phone or battery. If the phone or battery is dropped, especially on a hard surface, and the user suspects damage, take it to a service center for inspection.
- At least, one of the Authentication methods may be implemented. (e.g. H/W, S/W, Mechanical, Hologram, etc.)
- Improper battery use may result in a fire, explosion or other hazard.

Charger and Adapter Safety

- The charger and adapter are intended for indoor use only.
- Insert the battery pack charger vertically into the wall power socket.
- Only use the approved battery charger. Otherwise, you may cause serious damage to your phone.
- Use the correct adapter for your phone when using the battery pack charger abroad.

Battery Information and Care

- Please dispose of your battery properly or take it to your local wireless carrier for recycling.
- The battery doesn't need to be empty before recharging.
- Use only LG-approved chargers specific to your phone model since they are designed to maximize battery life.
- Do not disassemble or short-circuit the battery.
- Keep the battery's metal contacts clean.
- Replace the battery when it no longer provides acceptable

performance. The battery can be recharged several hundred times before replacement.

- Recharge the battery after long periods of non-use to maximize battery life.
- Battery life will vary due to usage patterns and environmental conditions.
- Use of extended backlighting, Browser, and data connectivity kits affect battery life and talk/standby times.
- The self-protection function of the battery cuts the power of the phone when its operation is in an abnormal state. In this case, remove the battery from the phone, reinstall it, and turn the phone on.

Explosion, Shock, and Fire Hazards

- Do not put your phone in a place subject to excessive dust and keep the minimum required distance between the power cord and heat sources.
- Unplug the power cord prior to cleaning your phone, and clean the power plug pin when it's dirty.

- When using the power plug, ensure that it's firmly connected. If not, it may cause excessive heat or fire.
- If you put your phone in a pocket or bag without covering the receptacle of the phone (power plug pin), metallic articles (such as a coin, paperclip or pen) may short-circuit the phone. Always cover the receptacle when not in use.
- Don't short-circuit the battery. Metallic articles such as a coin, paperclip or pen in your pocket or bag may short-circuit the + and – terminals of the battery (metal strips on the battery) upon moving. Short-circuit of the terminal may damage the battery and cause an explosion.

General Notice

- Using a damaged battery or placing a battery in your mouth may cause serious injury.
- Do not place items containing magnetic components such as a credit card, phone card, bank book, or subway ticket near your phone. The magnetism of the phone may damage the data stored in the magnetic strip.



Safety

- Talking on your phone for a long period of time may reduce call quality due to heat generated during use.
- When the phone is not used for a long period time, store it in a safe place with the power cord unplugged.
- Using the phone in proximity to receiving equipment (i.e., TV or radio) may cause interference to the phone.
- Do not use the phone if the antenna is damaged. If a damaged antenna contacts skin, it may cause a slight burn. Please contact an LG Authorized Service Center to replace the damaged antenna.
- Do not immerse your phone in water. If this happens, turn it off immediately and remove the battery. If the phone does not work, take it to an LG Authorized Service Center.
- Do not paint your phone.
- The data saved in your phone might be deleted due to careless use, repair of the phone, or upgrade of the software. Please backup your important phone numbers. (Ringtones, text messages, voice messages, pictures, and videos could also be deleted.) The manufacturer is not liable for damage due to the loss of data.
- When you use the phone in public places, set the ringtone to vibration so you don't disturb others.
- Do not turn your phone on or off when putting it to your ear.
- Use accessories, such as earphones and headsets, with caution. Ensure that cables are tucked away safely and do not touch the antenna unnecessarily.

Caution: ***Avoid potential hearing loss.***

Prolonged exposure to loud sounds (including music) is the most common cause of preventable hearing loss. Some scientific research suggests that using portable audio devices, such as portable music players and cellular telephones, at high volume settings for long durations may lead to permanent noise induced hearing loss. This includes the use of headphones (including headsets, earbuds and Bluetooth® or other wireless devices). Exposure to very loud sound has also been associated in some studies with tinnitus (a ringing in the ear), hypersensitivity to sound and distorted hearing. Individual susceptibility to noise-induced hearing loss and other potential hearing problems varies.

The amount of sound produced by a portable audio device varies depending on the nature of the sound, the device, the device settings and the headphones. You should follow some commonsense recommendations when using any portable audio device:

- Set the volume in a quiet environment and select the lowest volume at which you can hear adequately.
- When using headphones, turn the volume down if you cannot hear the people speaking near you or if the person sitting next to you can hear what you are listening to.
- Do not turn the volume up to block out noisy surroundings. If you choose to listen to your portable device in a noisy environment, use noise-cancelling headphones to block out background environmental noise.
- Limit the amount of time you listen. As the volume increases, less time is required before your hearing could be affected.
- Avoid using headphones after exposure to extremely loud noises, such as rock concerts, that might cause temporary hearing loss. Temporary hearing loss might cause unsafe volumes to sound normal.
- Do not listen at any volume that causes you discomfort. If you experience ringing in your ears,



hear muffled speech or experience any temporary hearing difficulty after listening to your portable audio device, discontinue use and consult your doctor.

You can obtain additional information on this subject from the following sources:

American Academy of Audiology

11730 Plaza American Drive, Suite

300

Reston, VA 20190

Voice: (800) 222-2336

Email: info@audiology.org

Internet: www.audiology.org

National Institute on Deafness and Other Communication Disorders

National Institutes of Health

31 Center Drive, MSC 2320

Bethesda, MD USA 20892-2320

Voice: (301) 496-7243

Email: nidcdinfo@nih.gov

Internet:

<http://www.nidcd.nih.gov/health/hearing>

National Institute for Occupational Safety and Health

Hubert H. Humphrey Bldg.

200 Independence Ave., SW

Washington, DC 20201

Voice: 1-800-35-NIOSH (1-800-356-4674)

Internet:

<http://www.cdc.gov/niosh/topics/noise/default.html>

FDA Consumer Update



The U.S. Food and Drug Administration's Center for Devices and

Radiological Health Consumer Update on Mobile Phones:

1. Do wireless phones pose a health hazard?

The available scientific evidence does not show that any health problems are associated with using wireless phones. There is no proof, however, that wireless phones are absolutely safe. Wireless phones emit low levels of Radio Frequency (RF) energy in the microwave range while being used. They also emit very low levels of RF when in standby mode. Whereas high levels of RF can produce health effects (by heating tissue), exposure to low level RF that does not produce heating effects causes no known adverse health effects. Many studies of low level RF exposures have not found any biological effects. Some studies have suggested that some biological effects may occur, but such findings have not been confirmed by additional research. In some

cases, other researchers have had difficulty in reproducing those studies, or in determining the reasons for inconsistent results.

2. What is the FDA's role concerning the safety of wireless phones?

Under the law, the FDA does not review the safety of radiation-emitting consumer products such as wireless phones before they can be sold, as it does with new drugs or medical devices. However, the agency has authority to take action if wireless phones are shown to emit Radio Frequency (RF) energy at a level that is hazardous to the user. In such a case, the FDA could require the manufacturers of wireless phones to notify users of the health hazard and to repair, replace, or recall the phones so that the hazard no longer exists. Although the existing scientific data does not justify FDA regulatory actions, the FDA has urged the wireless phone industry to take a number of steps, including the following:

- Support needed research into possible biological effects of RF of the type emitted by wireless phones;



- Design wireless phones in a way that minimizes any RF exposure to the user that is not necessary for device function; and
- Cooperate in providing users of wireless phones with the best possible information on possible effects of wireless phone use on human health.

The FDA belongs to an interagency working group of the federal agencies that have responsibility for different aspects of RF safety to ensure coordinated efforts at the federal level. The following agencies belong to this working group:

- National Institute for Occupational Safety and Health
- Environmental Protection Agency
- Occupational Safety and Health Administration
- National Telecommunications and Information Administration

The National Institutes of Health participates in some interagency working group activities, as well. The FDA shares regulatory responsibilities for wireless phones with the Federal Communications Commission (FCC). All phones that

are sold in the United States must comply with FCC safety guidelines that limit RF exposure. The FCC relies on the FDA and other health agencies for safety questions about wireless phones.

The FCC also regulates the base stations that the wireless phone networks rely upon. While these base stations operate at higher power than do the wireless phones themselves, the RF exposures that people get from these base stations are typically thousands of times lower than those they can get from wireless phones. Base stations are thus not the subject of the safety questions discussed in this document.

3. What kinds of phones are the subject of this update?

The term “wireless phone” refers here to handheld wireless phones with built-in antennas, often called “cell”, “mobile”, or “PCS” phones. These types of wireless phones can expose the user to measurable Radio Frequency (RF) energy because of the short distance between the phone and the user’s head.

These RF exposures are limited by FCC safety guidelines that were

developed with the advice of the FDA and other federal health and safety agencies. When the phone is located at greater distances from the user, the exposure to RF is drastically lower because a person's RF exposure decreases rapidly with increasing distance from the source. The so-called "cordless phones," which have a base unit connected to the telephone wiring in a house, typically operate at far lower power levels, and thus produce RF exposures far below the FCC safety limits.

4. What are the results of the research done already?

The research done thus far has produced conflicting results, and many studies have suffered from flaws in their research methods. Animal experiments investigating the effects of Radio Frequency (RF) energy exposures characteristic of wireless phones have yielded conflicting results that often cannot be repeated in other laboratories. A few animal studies, however, have suggested that low levels of RF could accelerate the development of cancer in laboratory animals. However, many of the studies that

showed increased tumor development used animals that had been genetically engineered or treated with cancer-causing chemicals so as to be pre-disposed to develop cancer in the absence of RF exposure. Other studies exposed the animals to RF for up to 22 hours per day. These conditions are not similar to the conditions under which people use wireless phones, so we do not know with certainty what the results of such studies mean for human health. Three large epidemiology studies have been published since December 2000. Between them, the studies investigated any possible association between the use of wireless phones and primary brain cancer, glioma, meningioma, or acoustic neuroma, tumors of the brain or salivary gland, leukemia, or other cancers. None of the studies demonstrated the existence of any harmful health effects from wireless phone RF exposures. However, none of the studies can answer questions about long-term exposures, since the average period of phone use in these studies was around three years.



5. What research is needed to decide whether RF exposure from wireless phones poses a health risk?

A combination of laboratory studies and epidemiological studies of people actually using wireless phones would provide some of the data that are needed. Lifetime animal exposure studies could be completed in a few years. However, very large numbers of animals would be needed to provide reliable proof of a cancer promoting effect, if one exists. Epidemiological studies can provide data that is directly applicable to human populations, but ten or more years follow-up may be needed to provide answers about some health effects, such as cancer. This is because the interval between the time of exposure to a cancer-causing agent and the time tumors develop — if they do — may be many, many years. The interpretation of epidemiological studies is hampered by difficulties in measuring actual RF exposure during day-to-day use of wireless phones. Many factors affect this measurement, such as the angle at which the phone is held, or which model of phone is used.

6. What is the FDA doing to find out more about the possible health effects of wireless phone RF?

The FDA is working with the U.S. National Toxicology Program and with groups of investigators around the world to ensure that high priority animal studies are conducted to address important questions about the effects of exposure to Radio Frequency (RF) energy.

The FDA has been a leading participant in the World Health Organization International Electro Magnetic Fields (EMF) Project since its inception in 1996. An influential result of this work has been the development of a detailed agenda of research needs that has driven the establishment of new research programs around the world. The project has also helped develop a series of public information documents on EMF issues.

The FDA and the Cellular Telecommunications & Internet Association (CTIA) have a formal Cooperative Research And Development Agreement (CRADA) to do research on wireless phone safety. The FDA provides the scientific oversight, obtaining input

from experts in government, industry, and academic organizations. CTIA-funded research is conducted through contracts with independent investigators. The initial research will include both laboratory studies and studies of wireless phone users. The CRADA will also include a broad assessment of additional research needs in the context of the latest research developments around the world.

7. How can I find out how much Radio Frequency energy exposure I can get by using my wireless phone?

All phones sold in the United States must comply with Federal Communications Commission (FCC) guidelines that limit Radio Frequency (RF) energy exposures. The FCC established these guidelines in consultation with the FDA and the other federal health and safety agencies. The FCC limit for RF exposure from wireless phones is set at a Specific Absorption Rate (SAR) of 1.6 watts per kilogram (1.6 W/kg). The FCC limit is consistent with the safety standards developed by the Institute of Electrical and Electronic

Engineering (IEEE) and the National Council on Radiation Protection and Measurement. The exposure limit takes into consideration the body's ability to remove heat from the tissues that absorb energy from the wireless phone and is set well below levels known to have effects. Manufacturers of wireless phones must report the RF exposure level for each model of phone to the FCC. The FCC website (<http://www.fcc.gov/oet/rfsafety>) gives directions for locating the FCC identification number on your phone so you can find your phone's RF exposure level in the online listing.

8. What has the FDA done to measure the Radio Frequency energy coming from wireless phones?

The Institute of Electrical and Electronic Engineers (IEEE) is developing a technical standard for measuring the Radio Frequency (RF) energy exposure from wireless phones and other wireless handsets with the participation and leadership of FDA scientists and engineers. The standard, "Recommended Practice for Determining the Spatial-Peak



Specific Absorption Rate (SAR) in the Human Body Due to Wireless Communications Devices: Experimental Techniques”, sets forth the first consistent test methodology for measuring the rate at which RF is deposited in the heads of wireless phone users. The test method uses a tissue-simulating model of the human head. Standardized SAR test methodology is expected to greatly improve the consistency of measurements made at different laboratories on the same phone. SAR is the measurement of the amount of energy absorbed in tissue, either by the whole body or a small part of the body. It is measured in watts/kg (or milliwatts/g) of matter. This measurement is used to determine whether a wireless phone complies with safety guidelines.

9. What steps can I take to reduce my exposure to Radio Frequency energy from my wireless phone?

If there is a risk from these products — and at this point we do not know that there is — it is probably very small. But if you are concerned about avoiding even potential risks, you can take a few

simple steps to minimize your exposure to Radio Frequency (RF) energy. Since time is a key factor in how much exposure a person receives, reducing the amount of time spent using a wireless phone will reduce RF exposure. If you must conduct extended conversations by wireless phone every day, you could place more distance between your body and the source of the RF, since the exposure level drops off dramatically with distance. For example, you could use a headset and carry the wireless phone away from your body or use a wireless phone connected to a remote antenna. Again, the scientific data does not demonstrate that wireless phones are harmful. But if you are concerned about the RF exposure from these products, you can use measures like those described above to reduce your RF exposure from wireless phone use.

10. What about children using wireless phones?

The scientific evidence does not show a danger to users of wireless phones, including children and teenagers. If you want to take steps to lower exposure to Radio

Frequency (RF) energy, the measures described above would apply to children and teenagers using wireless phones. Reducing the time of wireless phone use and increasing the distance between the user and the RF source will reduce RF exposure.

Some groups sponsored by other national governments have advised that children be discouraged from using wireless phones at all. For example, the government in the United Kingdom distributed leaflets containing such a recommendation in December 2000. They noted that no evidence exists that using a wireless phone causes brain tumors or other ill effects. Their recommendation to limit wireless phone use by children was strictly precautionary; it was not based on scientific evidence that any health hazard exists.

11. What about wireless phone interference with medical equipment?

Radio Frequency (RF) energy from wireless phones can interact with some electronic devices. For this reason, the FDA helped develop a detailed test method to measure Electro Magnetic Interference

(EMI) of implanted cardiac pacemakers and defibrillators from wireless telephones. This test method is now part of a standard sponsored by the Association for the Advancement of Medical Instrumentation (AAMI). The final draft, a joint effort by the FDA, medical device manufacturers, and many other groups, was completed in late 2000. This standard will allow manufacturers to ensure that cardiac pacemakers and defibrillators are safe from wireless phone EMI.

The FDA has tested hearing aids for interference from handheld wireless phones and helped develop a voluntary standard sponsored by the Institute of Electrical and Electronic Engineers (IEEE). This standard specifies test methods and performance requirements for hearing aids and wireless phones so that no interference occurs when a person uses a “compatible” phone and a “compatible” hearing aid at the same time. This standard was approved by the IEEE in 2000. The FDA continues to monitor the use of wireless phones for possible interactions with other medical devices. Should harmful



interference be found to occur, the FDA will conduct testing to assess the interference and work to resolve the problem.

12. Where can I find additional information?

For additional information, please refer to the following resources:

FDA web page on wireless phones
(<http://www.fda.gov/cellphones/>)

Federal Communications
Commission (FCC) RF Safety
Program
(<http://www.fcc.gov/oet/rfsafety>)

International Commission on Non-
Ionizing Radiation Protection
(<http://www.icnirp.de>)

World Health Organization (WHO)
International EMF Project
(<http://www.who.int/emf>)

National Radiological Protection
Board (UK)
(<http://www.nrpb.org.uk/>)

10 Driver Safety Tips

Your wireless phone gives you the powerful ability to communicate by voice almost anywhere, anytime. An important responsibility accompanies the benefits of wireless phones, one that every user must uphold.

When operating a car, driving is your first responsibility. When using your wireless phone behind the wheel of a car, practice good common sense and remember the following tips:

1. Get to know your wireless phone and its features such as speed dial and redial. Carefully read your instruction manual and learn to take advantage of valuable features most phones offer, including automatic redial and memory. Also, work to memorize the phone keypad so you can use the speed dial function without taking your attention off the road.
2. When available, use a hands-free device. A number of hands-free wireless phone accessories are readily available today. Whether you choose an installed mounted device for your

wireless phone or a speaker phone accessory, take advantage of these devices if available to you.

3. Make sure you place your wireless phone within easy reach and where you can reach it without removing your eyes from the road. If you get an incoming call at an inconvenient time, if possible, let your voicemail answer it for you.
4. Suspend conversations during hazardous driving conditions or situations. Let the person you are speaking with know you are driving; if necessary, suspend the call in heavy traffic or hazardous weather conditions. Rain, sleet, snow, and ice can be hazardous, but so is heavy traffic. As a driver, your first responsibility is to pay attention to the road.
5. Don't take notes or look up phone numbers while driving. If you are reading an address book or business card, or writing a "to-do" list while driving a car, you are not watching where you are going. It is common sense. Do not get caught in a dangerous situation because you
- are reading or writing and not paying attention to the road or nearby vehicles.
6. Dial sensibly and assess the traffic; if possible, place calls when you are not moving or before pulling into traffic. Try to plan your calls before you begin your trip or attempt to coincide your calls with times you may be stopped at a stop sign, red light, or otherwise stationary. But if you need to dial while driving, follow this simple tip -- dial only a few numbers, check the road and your mirrors, then continue.
7. Do not engage in stressful or emotional conversations that may be distracting. Stressful or emotional conversations and driving do not mix; they are distracting and even dangerous when you are behind the wheel of a car. Make people you are talking with aware you are driving and if necessary, suspend conversations which have the potential to divert your attention from the road.
8. Use your wireless phone to call for help. Your wireless phone is one of the greatest tools you can own to protect yourself and your



family in dangerous situations -- with your phone at your side, help is only three numbers away. Dial 911 or other local emergency number in the case of fire, traffic accident, road hazard, or medical emergency. Remember, it's a free call on your wireless phone!

9. Use your wireless phone to help others in emergencies. Your wireless phone provides you a perfect opportunity to be a "Good Samaritan" in your community. If you see an auto accident, crime in progress or other serious emergency where lives are in danger, call 911 or other local emergency number, as you would want others to do for you.
10. Call roadside assistance or a special wireless non-emergency assistance number when necessary. Certain situations you encounter while driving may require attention, but are not urgent enough to merit a call for emergency services. But you can still use your wireless phone to lend a hand. If you see a broken-down vehicle posing no serious hazard, a broken

traffic signal, a minor traffic accident where no one appears injured or a vehicle you know to be stolen, call roadside assistance or other special non-emergency wireless number.

The above tips are meant as general guidelines. Before deciding to use your mobile device while operating a vehicle, it is recommended that you consult your applicable jurisdiction's local laws or other regulations regarding such use. Such laws or other regulations may prohibit or otherwise restrict the manner in which a driver may use his or her phone while operating a vehicle.

Consumer Information on SAR

(Specific Absorption Rate)

This model phone meets the government's requirements for exposure to radio waves. Your wireless phone is a radio transmitter and receiver. It is designed and manufactured not to exceed the emission limits for exposure to Radio Frequency (RF) energy set by the Federal Communications Commission of the U.S. Government. These limits are part of comprehensive guidelines and establish permitted levels of RF energy for the general population. The guidelines are based on standards that were developed by independent scientific organizations through periodic and thorough evaluation of scientific studies. The standards include a substantial safety margin designed to assure the safety of all persons, regardless of age and health. The exposure standard for wireless mobile phones employs a unit of measurement known as the Specific Absorption Rate, or SAR. The SAR limit set by the FCC is 1.6 W/kg. Tests for SAR are conducted

using standard operating positions specified by the FCC with the phone transmitting at its highest certified power level in all tested frequency bands. Although SAR is determined at the highest certified power level, the actual SAR level of the phone while operating can be well below the maximum value. Because the phone is designed to operate at multiple power levels to use only the power required to reach the network, in general, the closer you are to a wireless base station antenna, the lower the power output.

Before a phone model is available for sale to the public, it must be tested and certified to the FCC that it does not exceed the limit established by the government-adopted requirement for safe exposure. The tests are performed in positions and locations (e.g., at the ear and worn on the body) as required by the FCC for each model. The highest SAR value for this model phone when tested for use at the ear is 1.26 W/kg and when worn on the body, as described in this user guide, is 0.473 W/kg (body-worn measurements differ among phone models, depending upon available accessories and FCC



requirements). While there may be differences between SAR levels of various phones and at various positions, they all meet the government requirement for safe exposure.

The FCC has granted an Equipment Authorization for this model phone with all reported SAR levels evaluated as in compliance with the FCC RF emission guidelines. SAR information on this model phone is on file with the FCC and can be found under the Display Grant section of

<http://www.fcc.gov/oet/fccid> after searching on FCC ID BEJWX7100. Additional information on Specific Absorption Rates (SAR) can be found on the Cellular Telecommunications Industry Association (CTIA) website at <http://www.ctia.org>.

* In the United States and Canada, the SAR limit for mobile phones used by the public is 1.6 watts/kg (W/kg) averaged over one gram of tissue. The standard incorporates a substantial margin of safety to give additional protection for the public and to account for any variations in measurements.

FCC Hearing-Aid Compatibility (HAC) Regulations for Wireless Devices

On July 10, 2003, the U.S. Federal Communications Commission (FCC) Report and Order in WT Docket 01-309 modified the exception of wireless phones under the Hearing Aid Compatibility Act of 1988 (HAC Act) to require digital wireless phones be compatible with hearing-aids. The intent of the HAC Act is to ensure reasonable access to telecommunications services for persons with hearing disabilities. While some wireless phones are used near some hearing devices (hearing aids and cochlear implants), users may detect a buzzing, humming, or whining noise. Some hearing devices are more immune than others to this interference noise, and phones also vary in the amount of interference they generate.

The wireless telephone industry has developed a rating system for wireless phones, to assist hearing device users to find phones that may be compatible with their hearing devices. Not all phones

have been rated. Phones that are rated have the rating on their box or a label located on the box.

The ratings are not guarantees.

Results will vary depending on the user's hearing device and hearing loss.

If your hearing device happens to be vulnerable to

interference, you may not be able to use a rated phone successfully.

Trying out the phone with your hearing device is the best way to evaluate it for your personal needs.

M-Ratings: Phones rated M3 or M4 meet FCC requirements and are likely to generate less interference to hearing devices than phones that are not labeled. M4 is the

better/higher of the two ratings.

T-Ratings: Phones rated T3 or T4 meet FCC requirements and are likely to generate less interference to hearing devices than phones that are not labeled. T4 is the better/higher of the two ratings.

Hearing devices may also be rated.

Your hearing device manufacturer or hearing health professional may help you find this rating. Higher ratings mean that the hearing

device is relatively immune to interference noise. The hearing aid and wireless phone rating values are then added together. A sum of 5

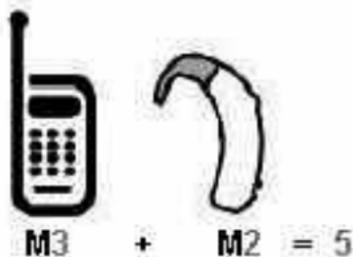

is considered acceptable for normal use. A sum of 6 is considered for best use.

In the above example, if a hearing aid meets the M2 level rating and the wireless phone meets the M3 level rating, the sum of the two values equal M5. This should provide the hearing aid user with "normal usage" while using their hearing aid with the particular wireless phone. "Normal usage" in this context is defined as a signal quality that's acceptable for normal operation.

The M mark is intended to be synonymous with the U mark. The T mark is intended to be synonymous with the UT mark. The M and T marks are recommended by the Alliance for Telecommunications Industries Solutions (ATIS). The U and UT marks are referenced in Section 20.19 of the FCC Rules. The HAC rating and measurement procedure are described in the



American National Standards Institute (ANSI) C63.19 standard. When you're talking over the cell phone, it's recommended you'd turn the BT (Bluetooth) mode off for HAC.

For information about hearing aids and digital wireless phones

FCC Hearing Aid Compatibility and Volume Control

<http://www.fcc.gov/cgb/dro/hearing.html>

Gallaudet University, RERC

<http://tap.gallaudet.edu/DigWireless.KS/DigWireless.htm>

HAAA (Hearing Loss Association of America)

<http://www.hearingloss.org/learn/cellphonetech.asp>

The Hearing Aid Compatibility FCC Order

http://hraunfoss.fcc.gov/edocs_public/atchmatch/FCC-03-168A1.pdf

There are a variety of accessories available for your phone and three easy ways to purchase them: shop online anytime at www.verizonwireless.com, call us at 1866 VZ GOT IT (894 6848) or visit one of our Verizon Wireless Communication Stores.





1. WHAT THIS WARRANTY COVERS:

LG offers you a limited warranty that the enclosed subscriber unit and its enclosed accessories will be free from defects in material and workmanship, according to the following terms and conditions:

- (1) The limited warranty for the product extends for TWELVE (12) MONTHS beginning on the date of purchase of the product with valid proof of purchase, or absent valid proof of purchase, FIFTEEN (15) MONTHS from date of manufacture as determined by the unit's manufacture date code.
- (2) The limited warranty extends only to the original purchaser of the product and is not assignable or transferable to any subsequent purchaser/end user.
- (3) This warranty is good only to the original purchaser of the product during the warranty period as long as it is in the U.S., including Alaska, Hawaii, U.S. Territories and Canada.
- (4) The external housing and cosmetic parts shall be free of defects at the time of shipment

and, therefore, shall not be covered under these limited warranty terms.

- (5) Upon request from LG, the consumer must provide information to reasonably prove the date of purchase.
- (6) The customer shall bear the cost of shipping the product to the Customer Service Department of LG. LG shall bear the cost of shipping the product back to the consumer after the completion of service under this limited warranty.

2. WHAT THIS WARRANTY DOES NOT COVER:

- (1) Defects or damages resulting from use of the product in other than its normal and customary manner.
- (2) Defects or damages from abnormal use, abnormal conditions, improper storage, exposure to moisture or dampness, unauthorized modifications, unauthorized connections, unauthorized repair, misuse, neglect, abuse, accident, alteration, improper installation, or other acts which

- are not the fault of LG, including damage caused by shipping, blown fuses, spills of food or liquid.
- (3) Breakage or damage to antennas unless caused directly by defects in material or workmanship.
 - (4) That the Customer Service Department at LG was not notified by consumer of the alleged defect or malfunction of the product during the applicable limited warranty period.
 - (5) Products which have had the serial number removed or made illegible.
 - (6) This limited warranty is in lieu of all other warranties, express or implied either in fact or by operations of law, statutory or otherwise, including, but not limited to any implied warranty of marketability or fitness for a particular use.
 - (7) Damage resulting from use of non LG approved accessories.
 - (8) All plastic surfaces and all other externally exposed parts that are scratched or damaged due to normal customer use.

- (9) Products operated outside published maximum ratings.
- (10) Products used or obtained in a rental program.
- (11) Consumables (such as fuses).

3. WHAT LG WILL DO:

LG will, at its sole option, either repair, replace or refund the purchase price of any unit that does not conform to this limited warranty. LG may choose at its option to use functionally equivalent re-conditioned, refurbished or new units or parts or any units. In addition, LG will not re-install or back-up any data, applications or software that you have added to your phone. It is therefore recommended that you back-up any such data or information prior to sending the unit to LG to avoid the permanent loss of such information.

4. STATE LAW RIGHTS:

No other express warranty is applicable to this product. THE DURATION OF ANY IMPLIED WARRANTIES, INCLUDING THE IMPLIED WARRANTY OF MARKETABILITY, IS LIMITED TO



LIMITED WARRANTY STATEMENT

THE DURATION OF THE EXPRESS WARRANTY HEREIN. LG SHALL NOT BE LIABLE FOR THE LOSS OF THE USE OF THE PRODUCT, INCONVENIENCE, LOSS OR ANY OTHER DAMAGES, DIRECT OR CONSEQUENTIAL, ARISING OUT OF THE USE OF, OR INABILITY TO USE, THIS PRODUCT OR FOR ANY BREACH OF ANY EXPRESS OR IMPLIED WARRANTY, INCLUDING THE IMPLIED WARRANTY OF MARKETABILITY APPLICABLE TO THIS PRODUCT.

Some states do not allow the exclusive limitation of incidental or consequential damages or limitations on how long an implied warranty lasts; so these limitations or exclusions may not apply to you. This warranty gives you specific legal rights and you may also have other rights which vary from state to state.

5. HOW TO GET WARRANTY SERVICE:

If you experience any problems with either the Bluetooth headset or the mobile handset, in each case as may be covered by this limited warranty, you need only return the affected device. For example, if a

problem exists with the Bluetooth headset, please DO NOT return your mobile handset with the headset. Likewise, if a problem exists with the mobile handset, please DO NOT return the Bluetooth Headset with the handset.

To obtain warranty service, please call or fax to the following telephone numbers from anywhere in the continental United States:

Tel. 1-800-793-8896 or Fax. 1-800-448-4026

Or visit <http://us.lgservice.com>.

Correspondence may also be mailed to:

LG Electronics Service- Mobile Handsets, P.O. Box 240007, Huntsville, AL 35824

DO NOT RETURN YOUR PRODUCT TO THE ABOVE ADDRESS. Please call or write for the location of the LG authorized service center nearest you and for the procedures for obtaining warranty claims.

Terminology

EZ Tip Calculator

Feature for easy bill calculation using the total cost, tip, and number of people as variables.

Advanced Voice Recognition

Feature that allows you to perform a wide range of verbal commands by training the phone to recognize your individual speech patterns.

Bluetooth® wireless technology

Technology used to allow mobile phones, computers, and other personal devices to be easily coordinated and interconnected using a short-range wireless connection.

MEDIA CENTER

Feature that accesses the Internet to provide the ability to access and even download a wide variety of software, information, and more right on your LG Verizon wireless phone.

Acronyms and Abbreviations

DTMF

Dual-**T**one **M**ulti **F**requency (or “touch-tone”) is a method used to communicate keys pressed on the phone. Pressing a key generates two simultaneous tones, one for the row and one for the column to determine which key was pressed.



ERI

Enhanced Roaming Indicator is a feature to indicate whether a mobile phone is on its home system, a partner network, or a roaming network. Many phones indicate home vs. roaming as an icon, but ERI capable phones can clearly indicate third “partner network” status.

GPS

Global Positioning System is a system of satellites, computers, and receivers able to determine the latitude and longitude of a specific receiver on Earth. Position is calculated using time and distance.

IS 2000

Type of digital signaling. It's the second generation of CDMA digital cellular, an extension of IS-95. Differences between signaling types have to do with pilot signal and links to provide more traffic channels, and control protocols.

NAM

Number Assignment Module is how the phone stores the phone number and its electronic serial number.

SSL

Secure Sockets Layer Protocol used to encrypt data sent over the air.

TTY

Teletypewriter. An electromechanical typewriter that either transmits or receives messages coded in electrical signals. A phone with TTY support is able to translate typed characters to voice or translate voice into characters to display on the TTY.

10 Driver Safety Tips 104

A

Accessories 111
Add New Device 64
Airplane Mode 75
Alarm Clock 62
Alert 69
Answer Options 81
Assisted Dialing 84
Auto Pair Handsfree 67
Auto Retry 82

B

Backlight 72
Banner 71
Battery Charge Level 19
Battery Temperature
Protection 18
Bluetooth® Menu 63

C

Calculator 60
Calendar 61
Call Settings 81
Call Sounds 68
Call Waiting 21
Caller ID 21
CDG2 81
Charging the Battery 18
Charging with USB 18
Chat 40
Clock Format 75
Consumer Information on
SAR 107
Contact List 27
CONTACTS 27
Current Country 78

D

Dialed 44
Display Settings 71
Display Themes 73
Drafts 39

E

Email 40
Erasing Messages 42
Ez Tip Calculator 60

F

FCC Hearing-Aid
Compatibility (HAC)
Regulations for Wireless
Devices 108
FDA Consumer Update 97
Font Size 74

G

Games 51
Get New Ringtones 47
Glossary 115
Groups 28

I

Icon Glossary 86
Important Safety
Precautions 1
In Case of Emergency (ICE)
29
Inbox 36

L

Language 77
LIMITED WARRANTY
STATEMENT 112
Location 77

M

Main Menu Settings 73
Making Calls 19
Master Volume 68
Memory 85
Menu Fonts 74
Menus Overview 15
Messaging Settings 40
Missed 43
Mobile IM 40
Mobile Web 52
Music & Tones 47
Mute Function 21
My Device Info 66
My Name Card 30
My Number 86

N

NAM Select 81
New Contact 27
New Message 31
Notepad 63

O

One Touch Dial 84
Online Album 51

P

Phone Info 85
Phone Overview 12
Phone Settings 75
Picture Message 34
Pictures 49
Power On/Off 70



Index

R

- Received 43
- Receiving Calls 20

S

- Safety Information 91
- Screen Icons 20
- Security 78
- Sent 38
- Service Alerts 70
- Set Shortcuts 76
- Signal Strength 19
- Sounds Settings 68
- Speed Dials 28
- Stopwatch 62
- Supported Profiles 67
- SW/HW Version 86

T

- Take Picture 50
- Technical Details 9
- Text Input 22
- TIA Safety Information 88
- Tools 58
- TTY Mode 82

V

- Vibrate Mode 21
- View Timers 45
- Voice Commands 21, 58
- Voice Message 36
- Voicemail 39
- Volume Quick Adjustment
21

W

- Wallpaper 73
- Wireless Sync Email 40
- World Clock 62

