

User Manual

PRODUCT NAME : 802.11a/b/g/n + Bluetooth Combo Module

MODEL NAME : TWCM-K005D

The information contained herein is the exclusive property of LG Innotek and shall not be distributed, reproduced or disclosed in whole or no in part without prior written permission of LG Innotek.

Table of Contents

No.	Description	Page
1	Features	2
2	Module Photo	2
3	Block Diagram	3
4	Storage Conditions	4
5	Operating Conditions	4
6	Pin Description	5
7	Outline Drawing	6
8	Packing Information	7

1. Features

TWCM-K005D is the module for IEEE 802.11a/b/g/n wireless LAN & Bluetooth4.1.

TWCM-K005D is based on MeidaTek MT7632 solution.

- IEEE 802.11 a/b/g/n Dual Band WLAN infrastructure
- Bluetooth 4.1 + HS
- Size : 40mm x46.5mm x 8.25mm
- 2.4GHz and 5GHz, internal PA and LNA
- Dual-band 2T2R mode with data rate up to 300Mbps
- Wake on WLAN and Bluetooth
- Two Metal Press antenna for WLAN and One External antenna for Bluetooth
- Host interface : USB 2.0 (WLAN & Bluetooth)
- Security : WAPI, WEP, WPRA, WPA2, WMM, AES, TKIP, CKP
- Application: DTV, DVR, HD DVD Player, Blue-ray Disk Player, STB

2. Module Photo

3. Block Diagram

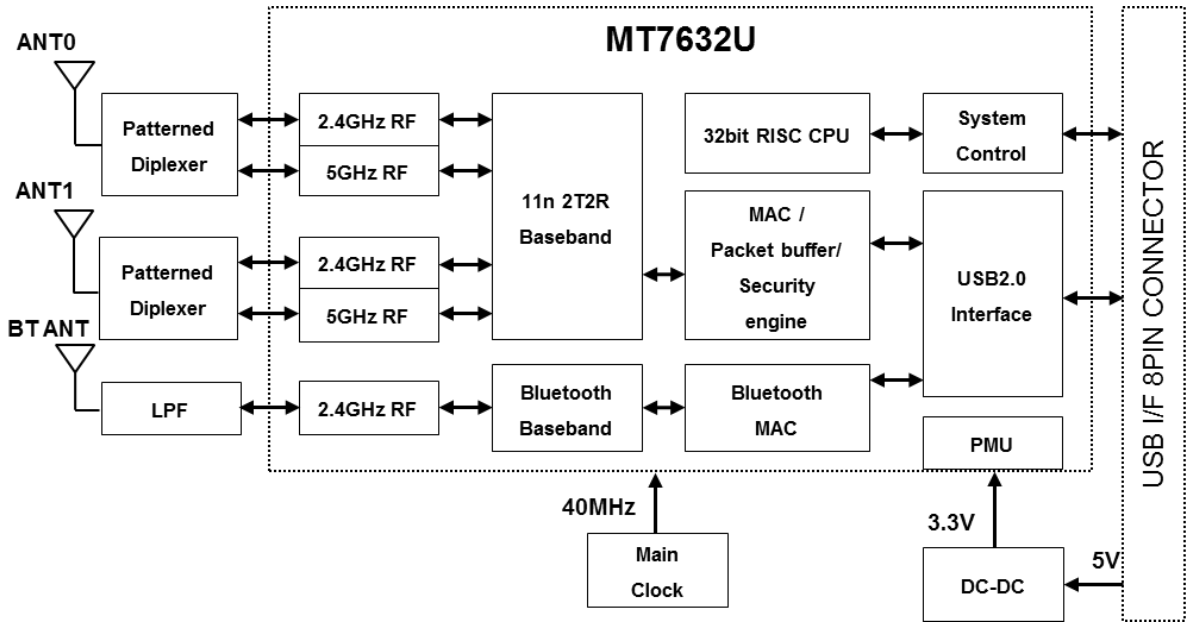

4. Storage Conditions

Caution : The specifications in Table 1 define levels at which permanent damage to the device can occur. Function operation is not guaranteed under these conditions.

Operating at absolute maximum conditions for extend periods can adversely affect the long-term reliability of the device.

Parameter	Min	Max	Unit
Storage Temperature	-10	+70	°C
Storage Humidity (40°C)	-	90	%

< Table 1 >

. Other conditions

1) Do not use or store modules in the corrosive atmosphere, especially where chloride gas, sulfide gas, acid, alkali, salt or the like are contained.

Also, avoid exposure to moisture.

2) Store the modules where the temperature and relative humidity do not exceed 5 to 40°C and 20 to 60%.

3) Assemble the modules within 6 months.

Check the soldering ability in case of 6 months over.

5. Operating Conditions

Parameter	Min	Typ	Max	Unit
Ambient Temperature	0	-	60	°C
Ambient Humidity (40°C)	-	-	85	%
Supply Voltage	4.75	5	5.25	Vdc

6. Pin Description

No.	Name	I/O	Description
1	VDD	I	VDD 5.0V
2	USB_DN	I/O	USB Communication signal USB_DN
3	USB_DP	I/O	USB Communication signal USB_DP
4	GND	-	GND
5	WoWLAN	O	Wake on Wireless LAN
6	GND	-	GND
7	BT_WAKE_HOST	O	Bluetooth wake-up signal
8	Reset	I	Reset controlled by main SOC

< Top View >

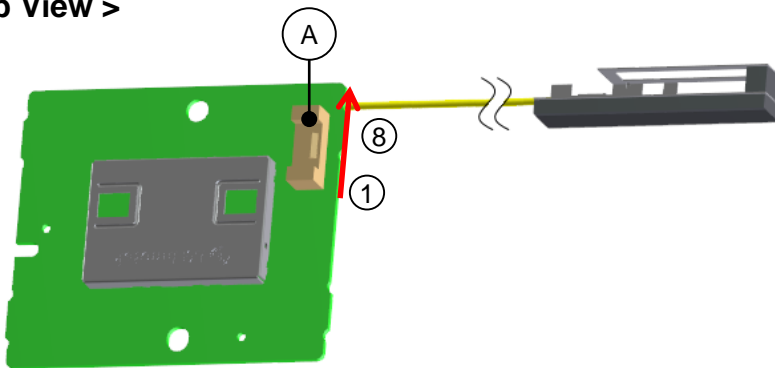

Note.

- 1) Recommend a Module install sequence for prevent USB device failure
 - Supply 5.0V power
 - Connect to data signal (USB_DP, USB_DN)
- 2) Connector (A) : Connector A1257WR0-8PS

< Bottom View >

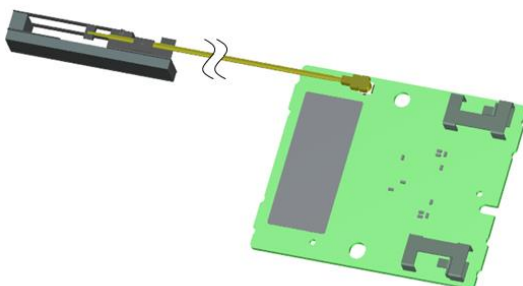

7. Outline Drawing

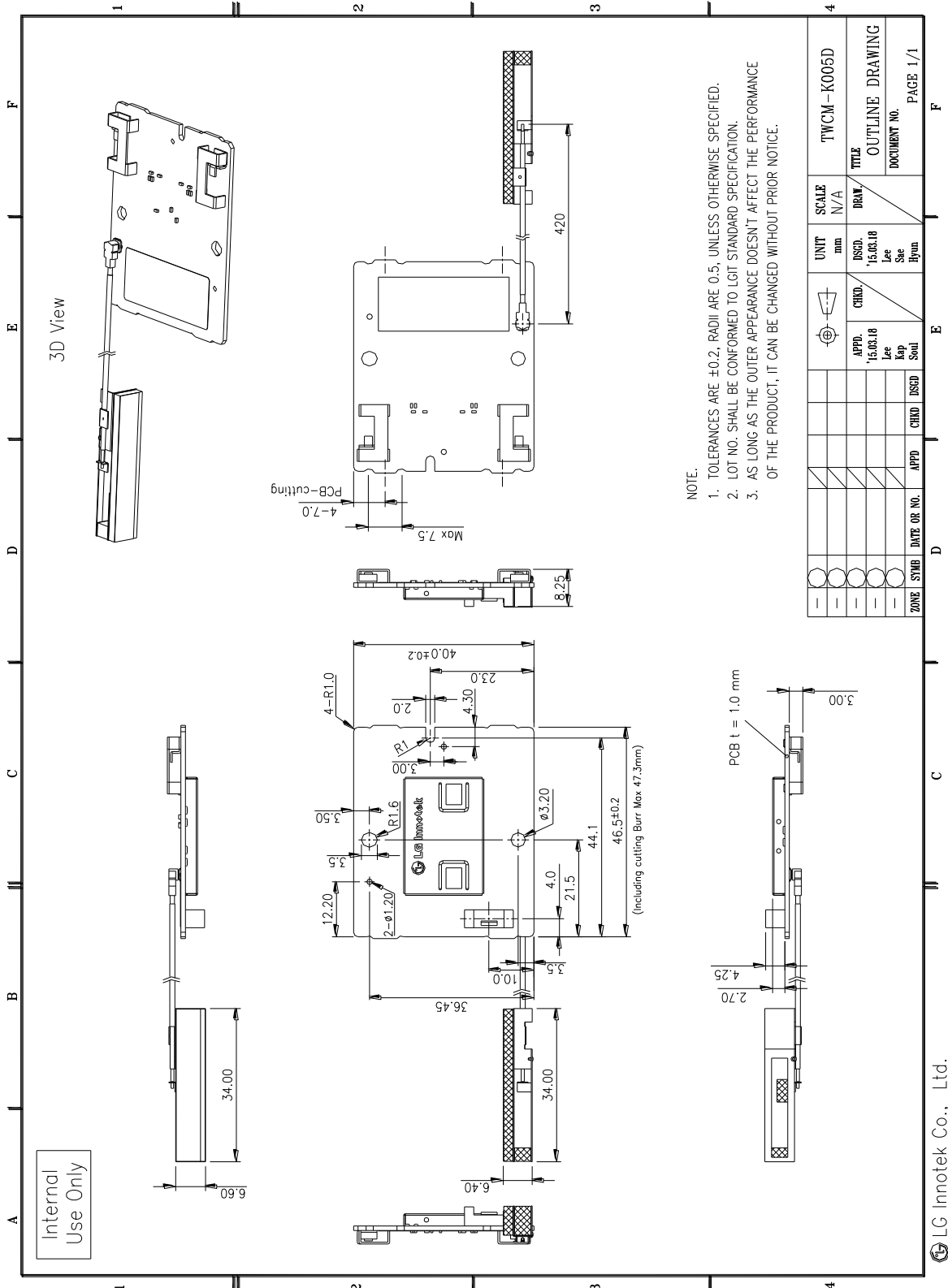

8. Packing Information

8-1. Tray packing

PACKING SPECIFICATION

Wifi module

- o 1 Tray Packing Q'ty : 45 EA
- o Tray Material : antistatic PET
- o 1 Tray Packing Weight : 508g±50g
(1 Module Weight : 7.3g±0.7g)

* Module's Top tray quantity must be 40 ea, then total packing will be 400 ea.

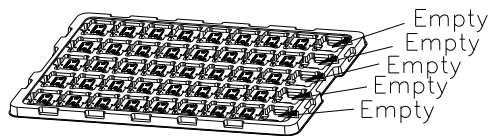
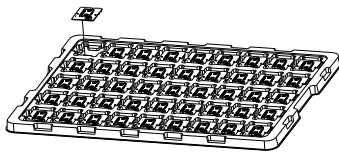

- o Tray Stack Q'ty : 11

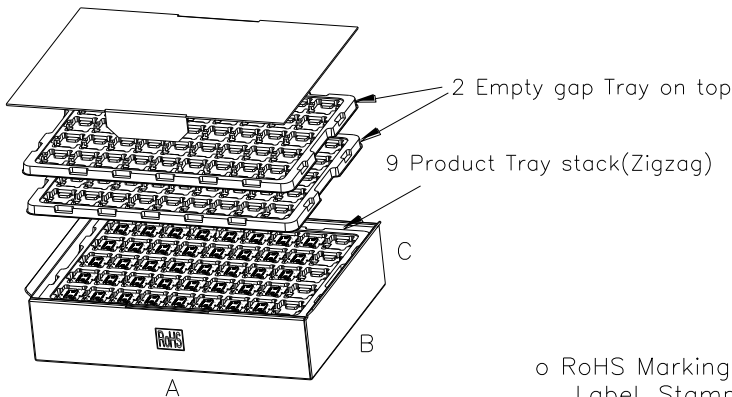

- o 1 Box Packing Q'ty : 400 EA
- o 1 Box Packing Weight : 5.4±0.5kg
- o Size : A X B X C (512 X 375 X 121.5)

- o RoHS Marking :
Label, Stamp, Printing
- o Marking Color :
Gray or Red for Stamp, Label,
Printing on the Board and etc.
Black only for Printing on Label.
- o Box Material : Corrugated Fibreboards

PART NO.		NAME		MATERIAL		SPEC.		FINISH		SIZE
										A4
										TWCM-K005D Packing Spec.
										TITLE EXP. Packing Specification
										DOCUMENT NO. Page (1/3)
ZONE	SYMB	DATE OR NO.	APPD	CHKD	DSGD	APPD. '15.03.16 Lee Kap Soul	CHKD.	DSGD. '15.03.16 Lee Sae Hyun	DRAW.	

8-2. Box packing

PACKING SPECIFICATION

Cable Ant.

- o Cable Ant Weight : $4.4g \pm 0.5g$
(Module 2.2g , PE bag 2.2g)

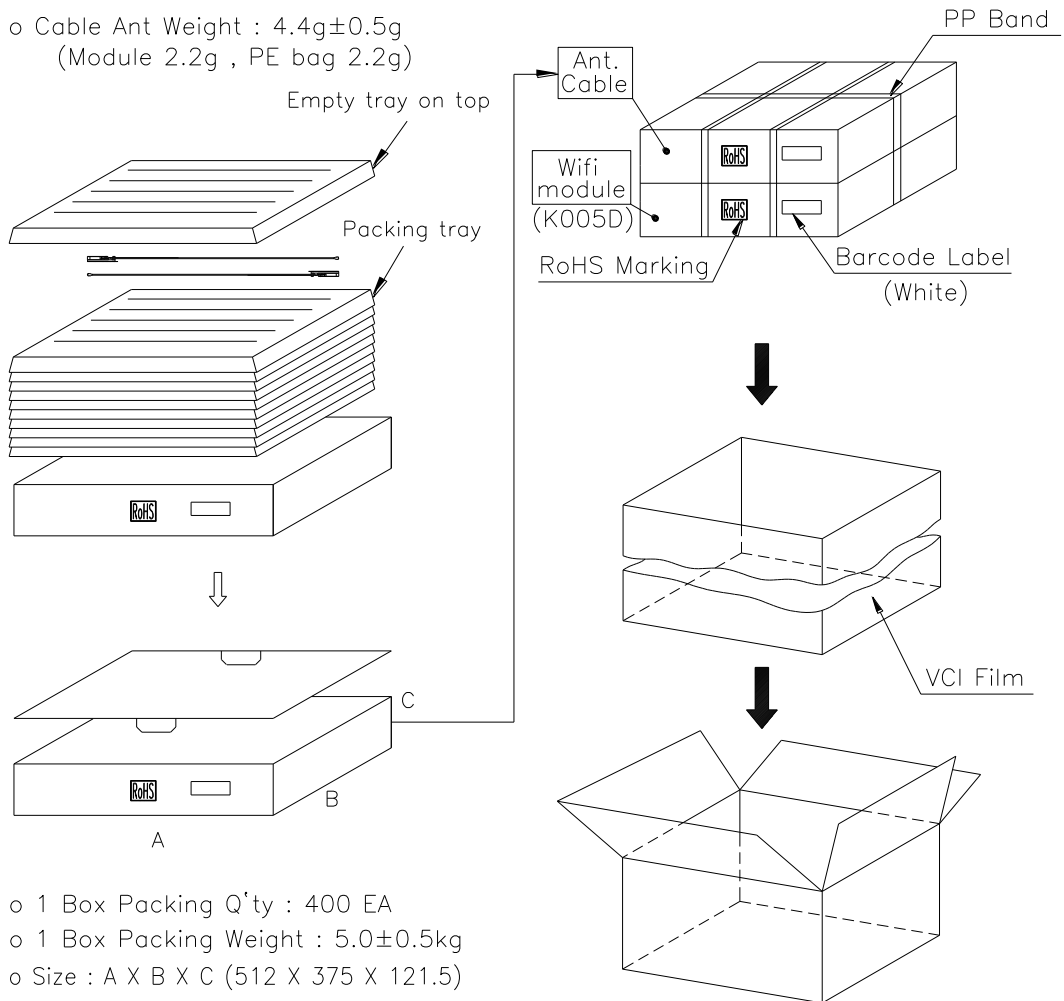

- o 1 Box Packing Q'ty : 400 EA
- o 1 Box Packing Weight : $5.0 \pm 0.5kg$
- o Size : A X B X C (512 X 375 X 121.5)

PART NO.		NAME		MATERIAL		SPEC.		FINISH		A4
						UNIT mm	SCALE	Ant. & Carton Packing Spec.		
					APPD. '15.03.16 Lee Kap Soul	CHKD.	DSGD. '15.03.16 Lee Soe Hyun	DRAW.	TITLE EXP. Packing Specification	
ZONE	SYMB	DATE OR NO.	APPD	CHKD	DSGD				DOCUMENT NO. Page 2/3	

8-2. Box packing

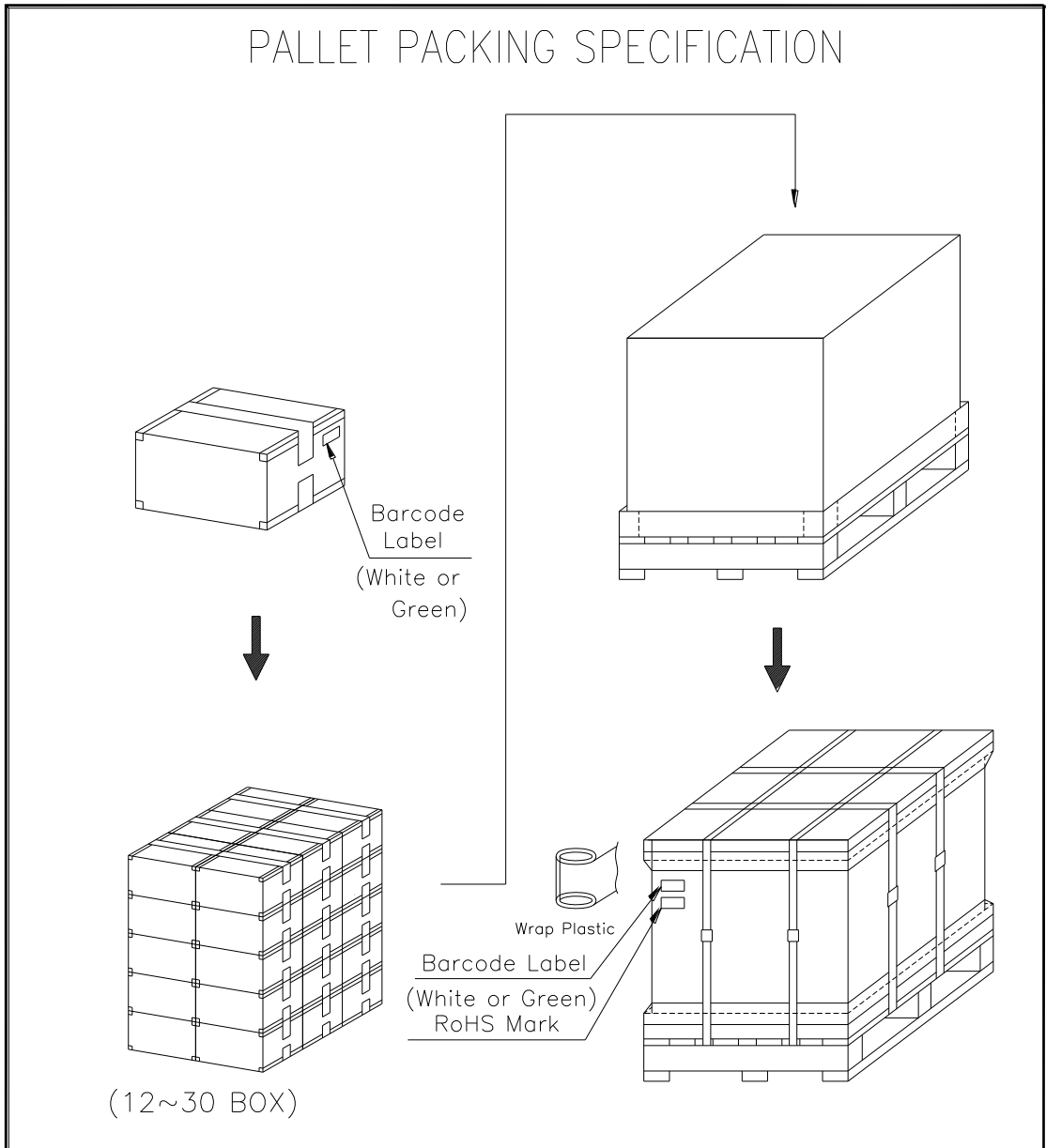

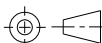
PART NO.		NAME		MATERIAL		SPEC.		FINISH		A4
							UNIT mm	SCALE	TWCM-K005D Packing Spec. (Pallet)	
						APPD. '15.03.16 Lee Kap Soul	CHKD.	DSCD. '15.03.16 Lee Sae Hyun	DRAW	TITLE EXP. Packing Specification
ZONE	SYMB	DATE OR NO.	APPD	CHKD	DSGD					DOCUMENT NO. Page (3/3)

FCC Information

This device complies with part 15 of the FCC Results. Operation is subject to the following two conditions :

- (1) This device may not cause harmful interface, and
- (2) This device must accept any interference received, including interference that may cause undesired operation.

Note: This equipment has been tested and found to comply with the limits for CLASS B digital device, pursuant to Part 15 of FCC Rules. These limits are designed to provide reasonable protection against harmful interference when the equipment is operated in a commercial environment This equipment generates, uses and can radiate radio frequency energy and, if not installed and used in accordance with the instructions, may cause harmful interference to radio communications. However, there is no guarantee that interference will not occur in a particular installation. If this equipment does cause harmful interference to radio or television reception, which can be determined by turning the equipment off and on, the user is encouraged to try correct the interference by one or more of the following measures:

- 1.1. Reorient or relocate the receiving antenna.
- 1.2. Increase the separation between the equipment and receiver.
- 1.3. Connect the equipment into an outlet on a circuit different from that to which receiver is connected.
- 1.4. Consult the dealer or experienced radio/TV technician for help.

WARNING

Changes or modifications not expressly approved by the manufacturer could void the user's authority to operate the equipment.

Information for OEM Integrator

This device is intended only for OEM integrators under the following conditions:

- 1) The antenna must be installed such that 20 cm is maintained between the antenna and users, and
- 2) The transmitter module may not be co-located with any other transmitter or antenna.

End product labelling

The label for end product must include "Contains FCC ID: YZP-TWCMK005D".

"CAUTION : Exposure to Radio Frequency Radiation.

This equipment complies with FCC radiation exposure limits set forth for an uncontrolled environment. This equipment must be installed and operated with minimum distance of 20cm between the radiator and your body. This transmitter module is authorized only for use in device where the antenna may be installed such that 20 cm may be maintained between the antenna and users."