User Guide for LTD-VL2000 (Eagle)

Product : LTE/CDMA(EVDO) Wireless Modem

Model name : LTD-VL2000

Table of Contents

1. Overview
2. Major feature
3. Interface
4. Electrical specification
5. RF specification
6. Mechanical specification
7. General specification
8. Connector
9. RFx information
10. FCC Approval

1. Overview

The LTD-VL2000 is achieved as personal mobile communication devices of the compact radio equipment, the latest design of the parts becoming smaller, lighter weight having the LTE(700/1700MHz), CDMA(850/1900MHz) bands. It is the vehicle's telematics system that connect with LTE and CDMA(EVDO) wireless network and the wireless module with voice and data communication. It can be operated at land, rivers, and other similar areas.

On LTE operating mode, It can be communicated with uplink 50Mbps, downlink up to 100Mbps data transfer speed such as a movie or a video call. It may be able to receive large amounts of data.

Standard RS-232 port and USB port communicating with the host system via AT-command or control commands can be used to send data. Voice calls are possible.

2. Major feature

Mechanical	Dimension	86.2(L) x 78.1(W) x 7.0(T) mm
	Weight	48g(max)
	Interface	USB, General Purpose I/O pins
	Antenna	FAKRA Connector
	Temperature *	Operation : -20℃ ~ +70 ℃ Storage : -40 ℃ ~ +85 ℃
Technology	Main Chipset	MDM 9615
	Memory	2048Mb(NAND) / 1024Mb(SDRAM)
	Standard	3GPP Rel.9 LTE - DL Speed : 100 Mbps(20M bandwidth) - UL Speed : 50 Mbps(20M bandwidth) 3GPP2 CDMA 1X, EVDO Rev.A - DL Speed : 3.1 Mbps - UL Speed : 1.8 Mbps
	Band	LTE B4, B13 CDMA 850(Cellular), 1900 (PCS) GPS Not Supported
	Power	LTE : Typ. 23dBm(Power Class 3) CDMA : Typ. 24dBm (Power Class 3)
ETC	DC Power	12V
	Functions	Voice, Data, SMS

3. Interface

3.1 Pin output

Customer P/N is connected with outer device using 40 pin connector

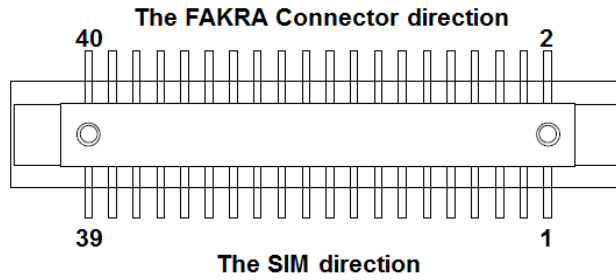

GND	2	1	KL30 (12V)
GND	4	3	KL30 (12V)
GND	6	5	KL30 (12V)
GND	8	7	KL30 (12V)
PowerOn_Off	10	9	NAD STATUS
USB GND	12	11	USB PWR_ON
USB NAD D-	14	13	USB NAD D+
NAD_Reset	16	15	NAD_OnOff
NC	18	17	HWAKEUP
NC	20	19	NC
NC	22	21	NC
D_Audio_NAD_LRCK	24	23	D_Audio_NAD_SCLK
D_Audio_NAD_SDTO	26	25	D_Audio_NAD_SDTI
NC	28	27	NC
NC	30	29	NC
NC	32	31	NC
NC	34	33	NC
NC	36	35	NC
NC	38	37	NC
NC	40	39	NC

Figure 1. Connector pin arrangement

3. Interface

3.2 Pin description

	Signal Name	Type	Pin	Description
USB	USB-NAD_D+ USB-NAD_D- USB_POW_ON USB-GND	IO IO I -	13 14 11 12	USB Differential data line (+) USB Differential data line (-) Control line USB Power Supply USB-Ground internal connected to GND
Audio PCM	D_Audio_NAD_SCLK D_Audio_NAD_LRCK D_Audio_NAD_SDTI D_Audio_NAD_SDTO	O O I O	23 24 25 26	PCM Interface bit clock line PCM Interface frame clock line PCM Interface digital audio data in PCM Interface digital audio data out
User Interface	NAD_OnOff NAD_Reset NAD_Status PowerOn_Off HWakeup	I I O I O	15 16 9 10 17	Control line to power on or off the module Control line to unconditionally restart the module Indicates the power state of the module Control line to switch on the power supply of LGIT-M. Optional Control line to switch on host.
Power	KL30 (12V) GND	I -	1,3,5,7 2,4,6,8	Power supply input (+) Power supply input (-)
NC	RESERVED	-	18,27,28, 29,30,31, 32,33,34, 35,36,37, 38,39,40	Reserved pins. Please leave the pins unconnected

Table 1. Pin descriptions

3. Interface

3.3 USB

It is supported with universal serial bus for high data communication. And It is satisfied with USB2.0 specification and supported with max.480Mbps

Pin NO.	Signal Name	Pin I/O (Modem host)	Function Description
13	USB-NAD_D+	IO	USB Differential data line (+)
14	USB-NAD_D-	IO	USB Differential data line (-)
11	USB_POW_ON	I	Control line USB Power Supply
12	USB-GND	-	USB-Ground internal connected to GND

Table 2. USB Pin descriptions

3. Interface

3.4 Audio

This module is provided with PCM interface. The resistor of pulled-up or pulled-down in this pin must be over 50Kohm.

Pin NO.	Signal Name	Pin I/O (Modem host)	Function Description
23	D_Audio_NAD_SCLK	O	PCM Interface bit clock line
24	D_Audio_NAD_LRCK	O	PCM Interface frame clock line
25	D_Audio_NAD_SDTI	I	PCM Interface digital audio data in
26	D_Audio_NAD_SDTO	O	PCM Interface digital audio data out

Table 3. PCM Pin descriptions

3.5 User interface

Pin No.	Signal Name	Direction	Function
15	NAD_OnOff	I	Turn on and off the module Active High
9	NAD_Status	O	Indicate the active status of module Active High
10	PowerOn_Off	O	Supply the power of module Active High
17	HwakeUP	O	Be used to wake up the host system Active Low
11	USB_Pow_On	I	Communicate with USB device Active High

Table 4. User interface Pin descriptions

4. Electrical specification

4.1 Power supply specification

A Module Power supply(KL30) is delivered on DC 12V, 1.5A from host system. In Module internal power supply, it is design for power management integral circuits to distribute constant voltages, and can control the each power block to minimize the power consumptions.

In particular, PAM(power amplifier module) has much power consumption so it is supplied for directly 3.8V converted from KL30. Therefore it should be careful to input the supply power of PAM when the absolute rating is over. In addition, all of power input should be design with blocking and protecting high surge and ESD in NAD module.

Pin No.	Signal Name	Direction	MIN	TYP	MAX
1, 3, 5,7	KL30(V_BATT)	I	10.8V	12V	13.2V

Table 5. Power supply specification

4. Electrical specification

4.2 Logic level specification

4.2.1 Digital logic level specification

NAD Control Lines						
Signal Name	Type	Low		High		Units
		min.	max.	min.	max.	
NAD_OnOff	I	0	0,8	2	3,5	V
NAD_Reset	I	0	0,8	2	3,5	V
NAD_Status	O	0	0,2	2,6	3,3	V
PowerOn_Off	I	0	0,8	2	3,5	V
HWakeUp	O	0	0,35	tristate	tristate	V

Table 6. Digital logic level specification

5. RF specification

5.1 CDMA

5.1.1 Receiver

- .- Bandwidth : 1.25MHz
- .- Frequency : 869MHz – 894MHz (BC0), 1930MHz – 1990MHz (BC1)
- .- RF to Baseband Direct conversion (Zero IF)
- .- Modulation method : QPSK, 8PSK and 16QAM
- .- Sensitivity : ≤ -104 dBm (PER = Under 0.5%)

5.1.2 Transmitter

- .- Frequency: 824MHz – 849MHz (BC0), 1850MHz – 1910MHz (BC1)
- .- Maximum RF Output : Power class3 (BC0), 23.01dBm ~ 25.5dBm
Power class2 (BC1), 23.01dBm ~ 25.5dBm
- .- Modulation method : BPSK, QPSK AND 8PSK
- .- Baseband to RF Direct conversion (Zero IF)

5.2 LTE

5.2.1 Receiver

- .- Bandwidth : B4(1.4/3/5/10/15/20MHz), B13(5/10MHz)
- .- Frequency : 2110MHz – 2155MHz (B4), 746MHz – 756MHz (B13)
- .- RF to Baseband Direct conversion (Zero IF)
- .- Modulation method : QPSK, 16QAM and 64QAM
- .- Sensitivity : Main - B4 (≤ -93.3 dBm @QPSK), B13(≤ -93.3 dBm @QPSK)
Diversity - B4 (≤ -93.3 dBm @QPSK), B13(≤ -93.3 dBm @QPSK)

5.2.2 Transmitter

- .- Frequency : B4 (1710MHz – 1755MHz), B13(777MHz – 787MHz)
- .- Maximum RF Output : Power class 3, 21.5dBm ~ 24.5dBm
- .- Modulation method : QPSK and 16QAM
- .- Baseband to RF Direct conversion (Zero IF)

6. Mechanical specification

6.1 Mechanical dimensions

Dimensions	86.2(L) x 78.1(W) x 7.0(T) mm
Weight	48 grams(max.)
Modem Interface connector	ISMA-9827B-40Y955 (Manufacture vendor : IRISO)
Modem Antenna Connector (Plug)	59S2DA-40MT5_D (Manufacture vendor : Rosenberger)

Table 7. Mechanical specification

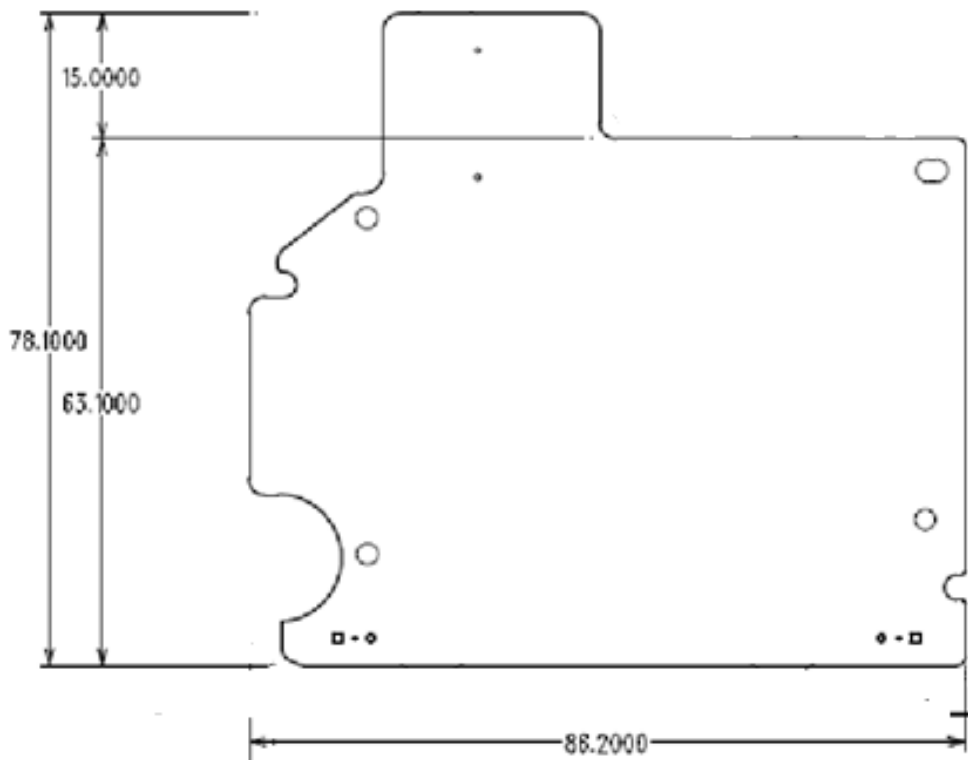

Figure 2. Mechanical dimension

6. Mechanical specification

6.1 Environment specification

- .- Storage Temp : -40°C ~ +85°C
- .- Operating Temp : -20°C ~ +70°C
 - (-20°C ~ +70°C : 3GPP specifications are satisfied
 - 30°C~-20°C, +70°C~+80°C : It can be performance degradation)
- .- Operating humidity : 80% (60°C) relative humidity

7. General specification

7.1 CDMA electrical specification

	Test item		Spec.	CHANNEL		
				1011/25	384/600	779/1175
4.4.5	Maximum Output Power		23.01~25.5dBm	PASS	PASS	PASS
4.5.1	Conducted Spurious Emissions	885 kHz to 1.98 MHz	-42 dBc↓/30 kHz	PASS	PASS	PASS
		1.98 MHz to 4.00 MHz	-54 dBc↓/30 kHz (BC0) -50 dBc↓/30 kHz (BC1)	PASS	PASS	PASS
4.4.6	Minimum Controlled Output Power		-50dBm↓	PASS	PASS	PASS
4.3.4	Waveform Quality	Rho	0.94 ~1.00	PASS	PASS	PASS
		Freq_E	+/-300.00Hz(BC0) +/-150.00Hz(BC1)	PASS	PASS	PASS
		Time_E	-1.00~1.00 us	PASS	PASS	PASS
4.4.4	Range of Closed Loop Power Control	up @ Full rate	24↑	PASS	PASS	PASS
		down @ Full Rate	-24↓	PASS	PASS	PASS
		up @ Half rate	24↑	PASS	PASS	PASS
		down @ Half Rate	-24↓	PASS	PASS	PASS
		up @ Quarter rate	24↑	PASS	PASS	PASS
		down @ Quarter Rate	-24↓	PASS	PASS	PASS
		up @ Eighth rate	24↑	PASS	PASS	PASS
		down @ Eighth Rate	-24↓	PASS	PASS	PASS
4.4.2	Time Response of Open Loop Control		PASS	PASS	PASS	PASS
4.4.1	Range of Open Loop Power	Open Loop Power Upper	-57.50~-38.50(BC0) -60.50~-41.50(BC1)	PASS	PASS	PASS
		Open Loop Power Mid	-17.50~1.50(BC0) -20.50~-1.50(BC1)	PASS	PASS	PASS
		Open Loop Power Sense	10.50~29.50(BC0) 10.50~29.50(BC1)	PASS	PASS	PASS
3.5.1	Reference Sensitivity Level(-104/-25)		0.5%↓	PASS	PASS	PASS

Table 9. CDMA RF specification

7. General specification

7.2 LTE B4(20M) electrical specification

	시험 항목	Spec.	Test Temperature	Channel		
				2050	2175	2300
6.2.2	Maximum Output Power(class 3)	23±1.5dBm	Normal, Temp L, Temp H	PASS	PASS	PASS
6.3.2	Minimum Output Power	-39dBm ↓	Normal, Temp L, Temp H	PASS	PASS	PASS
6.5.1	Frequency Error	±0.1ppm	Normal, Temp L, Temp H	PASS	PASS	PASS
6.5.2.1	Error Vector Magnitude(EVM)	17.5%↓ (QPSK)	Normal	PASS	PASS	PASS
		12.5%↓ (16QAM)		PASS	PASS	PASS
6.5.2.2	Relative Carrier Leakage Power	Carrier Leakage (3.2dBm ± 3.2dB)	Normal, Temp L, Temp H	PASS	PASS	PASS
		Carrier Leakage (-26.8dBm ± 3.2dB)		PASS	PASS	PASS
		Carrier Leakage (-36.8dBm ± 3.2dB)		PASS	PASS	PASS
6.5.2.4	EVM equalizer spectrum flatness	EVM equalizer spectrum flatness Range1	Normal, Temp L, Temp H	PASS	PASS	PASS
		EVM equalizer spectrum flatness Range2		PASS	PASS	PASS
6.6.1	Occupied Bandwidth (OBW)	20 MHz ↓	Normal	PASS	PASS	PASS
6.6.2.1	Spectrum emission mask	Spectrum Emission Mask upper/lower Area 1	Normal	PASS	PASS	PASS
		Spectrum Emission Mask upper/lower Area 2		PASS	PASS	PASS
		Spectrum Emission Mask upper/lower Area 3		PASS	PASS	PASS
		Spectrum Emission Mask upper/lower Area 4		PASS	PASS	PASS
6.6.2.3	Adjacent Channel Leakage Power Ratio (ACLR)	ACLR E-UTRA ±	Normal, Temp L, Temp H	PASS	PASS	PASS
		ACLR UTRA Offset 1 ±		PASS	PASS	PASS
		ACLR UTRA Offset 2 ±		PASS	PASS	PASS
7.3	Reference Sensitivity Level @ 20MHz	Main Ref Sense throughput shall be ≥ 95%	Normal, Temp L, Temp H	PASS	PASS	PASS
		Div. Ref Sense throughput shall be ≥ 95%		PASS	PASS	PASS
7.4	Maximum Input Level	throughput shall be ≥ 95%	Normal	PASS	PASS	PASS

Table 10. LTE B4(20M) RF specification

7. General specification

7.3 LTE B13(10M) electrical specification

	시험 항목	Spec.	Test Temperature	Channel		
				2050	2175	2300
6.2.2	Maximum Output Power(class 3)	23±1.5dBm	Normal, Temp L, Temp H	PASS	PASS	PASS
6.3.2	Minimum Output Power	-39dBm ↓	Normal, Temp L, Temp H	PASS	PASS	PASS
6.5.1	Frequency Error	±0.1ppm	Normal, Temp L, Temp H	PASS	PASS	PASS
6.5.2.1	Error Vector Magnitude(EVM)	17.5%↓ (QPSK)	Normal	PASS	PASS	PASS
		12.5%↓ (16QAM)		PASS	PASS	PASS
6.5.2.2	Relative Carrier Leakage Power	Carrier Leakage (3.2dBm ± 3.2dB)	Normal, Temp L, Temp H	PASS	PASS	PASS
		Carrier Leakage (-26.8dBm ± 3.2dB)		PASS	PASS	PASS
		Carrier Leakage (-36.8dBm ± 3.2dB)		PASS	PASS	PASS
6.5.2.4	EVM equalizer spectrum flatness	EVM equalizer spectrum flatness Range1	Normal, Temp L, Temp H	PASS	PASS	PASS
		EVM equalizer spectrum flatness Range2		PASS	PASS	PASS
6.6.1	Occupied Bandwidth (OBW)	10 MHz ↓	Normal	PASS	PASS	PASS
6.6.2.1	Spectrum emission mask	Spectrum Emission Mask upper/lower Area 1	Normal	PASS	PASS	PASS
		Spectrum Emission Mask upper/lower Area 2		PASS	PASS	PASS
		Spectrum Emission Mask upper/lower Area 3		PASS	PASS	PASS
		Spectrum Emission Mask upper/lower Area 4		PASS	PASS	PASS
6.6.2.3	Adjacent Channel Leakage Power Ratio (ACLR)	ACLR E-UTRA ±	Normal, Temp L, Temp H	PASS	PASS	PASS
		ACLR UTRA Offset 1 ±		PASS	PASS	PASS
		ACLR UTRA Offset 2 ±		PASS	PASS	PASS
7.3	Reference Sensitivity Level @ 10MHz	Main Ref Sense throughput shall be ≥ 95%	Normal, Temp L, Temp H	PASS	PASS	PASS
		Div. Ref Sense throughput shall be ≥ 95%		PASS	PASS	PASS
7.4	Maximum Input Level	throughput shall be ≥ 95%	Normal	PASS	PASS	PASS

Table 11. LTE B13(10M) RF specification

8. Connector

8.1 Antenna Connector : 59S2DA-40MT5_D (Vendor : Rosenberger)

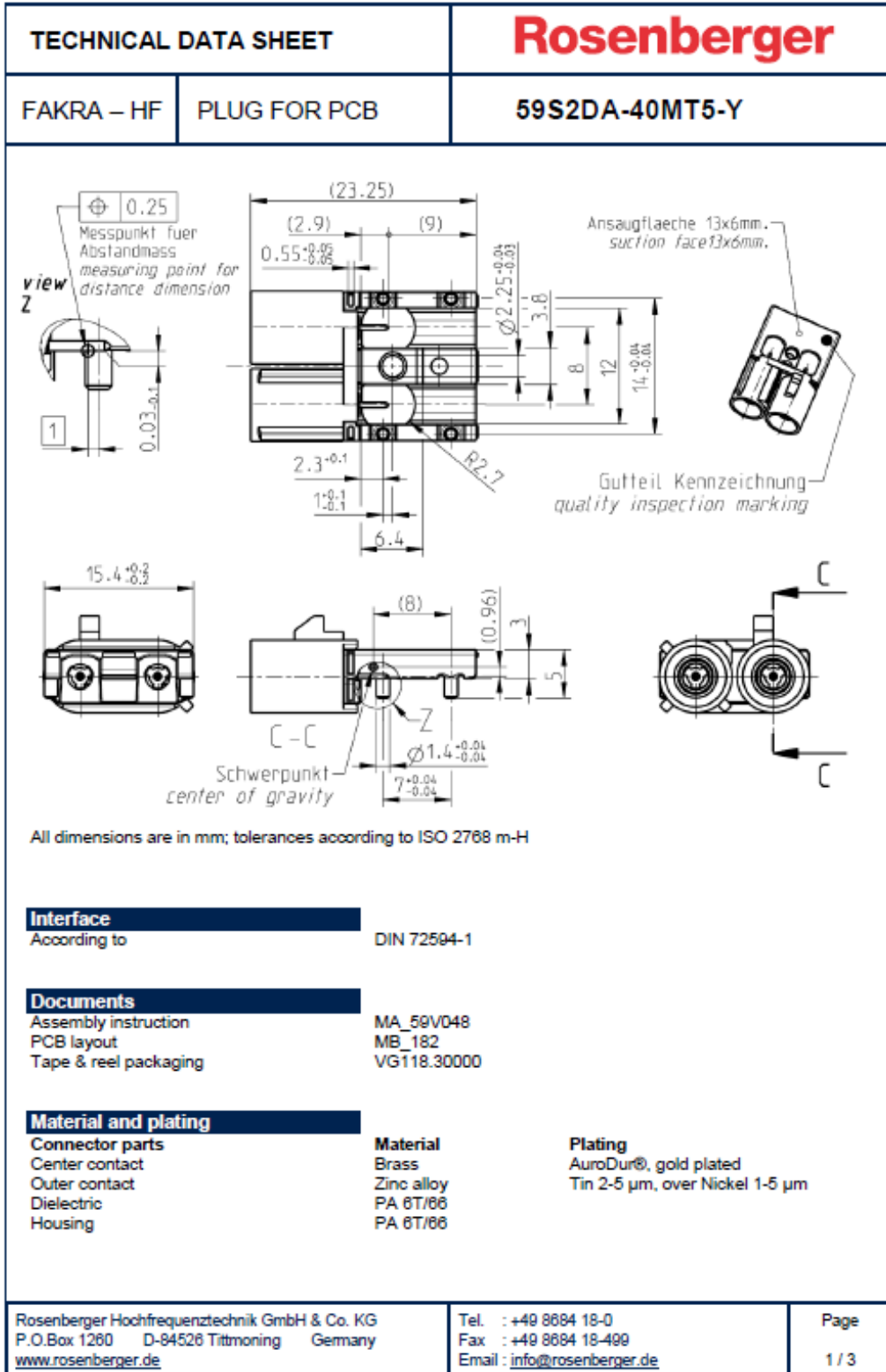

Dieses Dokument ist urheberrechtlich geschützt • This document is protected by copyright • Rosenberger Hochfrequenztechnik GmbH & Co. KG

RF_3505_10/6.0

9. RFx Information

The RF field strength of the wireless module or modules that may be embedded in your TCU is well all international RF exposure limits as known at this time. Because the wireless modules(which may be embedded into your TCU) emit less energy than is allowed in radio frequency safety standards and recommendations, manufacturer believes these modules are safe for use.

Regardless of the power levels, care should be taken to minimize human contact during normal operation. This module should be used more than 20cm(8 inches) from the body when wireless devices are on and transmitting.

This transmitter must not be collocated or operate in conjunction with any other antenna or transmitter. Operation is subject to the following two conditions: (1) this module may not cause interference , (2) this module must accept any interference that may cause undesired operation.

10.1 Information for integrator

The integrator has to be aware not to provide information to the end user regarding how to install or remove this RF module in the user manual of the end product. The user manual which is provided by integrators for end users must include the following information in a prominent location. To comply with FCC RF exposure compliance requirements, the antenna used for this transmitter must be installed to provide a separation distance of at least 20cm from all persons and must not be collocated or operating in conjunction with any other antenna or transmitter. Label for end product must include contains FCC ID : YZP-VL2000 or A RF transmitter inside, FCC ID : YZP-VL2000

10. FCC Approval

This Module complies with parts 22, 24, 27 of the FCC rules.

This device complies with FCC radiation exposure limits set forth for an uncontrolled environment.

This module should be installed and operated with minimum distance 20cm between the radiating element of this device and the user.

This module may not be co-located with any other transmitters or antennas. To comply with FCC regulations limiting both maximum RF output power and human exposure to RF radiation, the maximum antenna gain including cable loss in a mobile-only exposure condition must not exceed the table below.

Band	Frequency Range [MHz]	Maximum Antenna Gain[dBi]
CDMA(Cellular)	824.70~848.31	6.00
CDMA(PCS)	1851.25~1908.75	7.50
LTE(B13)	777.00 ~784.50	6.49
LTE(B4)	1710.70~1754.30	5.49

To satisfy FCC exterior labeling requirements, the following text must be placed on the exterior of the end product.

Contains Transmitter module FCC ID: YZP-VL2000

Changes or modifications to this equipment may cause harmful interference unless the modifications are expressly approved in the instruction manual. The user could lose the authority to operate this equipment if an unauthorized change or codification is made.

Note: If this module is intended for use in a portable device, additional testing will be required to satisfy RF Exposure, including SAR requirements of FCC Part 2.1093.