



Linear Actuators and Electronics User Manual

Contents

| | |
|---|----|
| Preface | 5 |
| Valid for | 6 |
| Important information | 7 |
| General assembly instructions | 11 |
| Declaration of incorporation of partly completed machinery | 12 |
| 1. System description | 13 |
| Electrostatic discharge (ESD) | 13 |
| Fundamental actuator construction | 14 |
| General Warranty periods | 14 |
| IP Protection degree | 15 |
| IPX6 Washable | 15 |
| Cable Wash | 16 |
| Maintenance | 17 |
| Environmental conditions | 17 |
| Insulation class | 18 |
| Key to symbols | 18 |
| ETL marking | 19 |
| Mounting | 19 |
| Drawings | 20 |
| Connecting the system | 26 |
| Batteries | 27 |
| 2. Information on start-up, deinstallation and operation | 29 |
| Troubleshooting Actuators/Lifting columns | 30 |
| Troubleshooting Electronics | 30 |
| 3. Information on specific actuators | 31 |
| LA20 Inline | 31 |
| LA23 DESKLINE® | 36 |
| LA23 MEDLINE® CARELINE® TECHLINE® | 37 |
| LA23 IC | 48 |
| LA27 | 52 |
| LA28 | 55 |
| LA28 Compact | 56 |
| LA29 | 56 |
| LA30 | 59 |
| LA31 | 60 |
| LA34 | 65 |
| LA40 HOMELINE® | 67 |
| LA40 MEDLINE® CARELINE® | 68 |
| LA44 | 77 |
| 4. Information on specific columns | 80 |
| BL1 | 80 |
| LC3 | 85 |

| | |
|---|------------|
| 5. Information on specific control boxes | 104 |
| General information | 104 |
| CA30 / CA40 | 105 |
| CA63 | 108 |
| CB6 | 113 |
| CB6P2 | 114 |
| CB7 | 114 |
| CB8A | 115 |
| CB8-T | 115 |
| CB9 HOMELINE® | 115 |
| CB9 CARELINE® and CB9 CARELINE® BASIC | 116 |
| CB20 | 117 |
| CBR1 | 117 |
| CO53 | 118 |
| CO61 | 124 |
| CO65 | 129 |
| CO71 | 134 |
| OPS | 139 |
| PJ2 | 142 |
| 6. Information on specific controls | 146 |
| ABL | 146 |
| ACC | 149 |
| ACK | 149 |
| ACL | 149 |
| ACO | 150 |
| ACOM | 150 |
| DPH Medical | 151 |
| FPP | 152 |
| FS | 153 |
| FS3 | 154 |
| HB30 | 158 |
| HB70 | 159 |
| HB80 | 159 |
| HB100 | 160 |
| HB190 | 161 |
| HB200 | 162 |
| HD80 | 165 |
| HD80 JUMBO | 166 |
| HL70 | 166 |
| HL80 | 167 |
| LS | 167 |
| LSD | 167 |
| 7. Information on specific JUMBO™ | 168 |
| BAJ | 168 |
| BAJL Li-Ion | 170 |
| CBJ1 / CBJ2 | 171 |
| CBJ-Care | 174 |
| CBJ-Home | 177 |
| COBO | 178 |
| CH01 2 nd generation | 179 |
| CHJ2 | 179 |
| MBJ1/2/3 | 180 |

| | |
|---|------------|
| 8. Information on specific accessories | 183 |
| General information | 181 |
| BA16 Lead acid | 181 |
| BA18 | 183 |
| BA19 Lead acid | 184 |
| BA21 Li-Ion | 186 |
| CS16 | 190 |
| DJB | 190 |
| Massage Motor Medical | 191 |
| MJB2 | 192 |
| MJB5 Plus Port Repeater | 193 |
| MJB5 Plus SMPS | 198 |
| MJB5 Plus Gateway | 203 |
| MJB5 Plus UBL (int) | 210 |
| MJB5 Plus UBL (ext) | 216 |
| MJB5 Plus AOC | 222 |
| Simulator tool | 231 |
| SLS | 232 |
| Under Bed Light | 233 |
| Under Bed Light 2 | 234 |
| QLC12 | 235 |
| 9. Information on specific LIFT products | 238 |
| CAL40 | 238 |
| BAL40 | 250 |
| CHL40 | 252 |
| COL50 | 253 |
| BAL50 | 265 |
| CHL50 | 267 |
| 10. Repair and disposal | 270 |
| Addresses | 271 |

Preface

Dear User,

We are delighted that you have chosen a LINAK® product.

LINAK systems are high-tech products based on many years of experience in the manufacture and development of actuators, electric control boxes, controls, batteries, accessories and chargers.

This User Manual does not address the end user. It is intended as a source of information for the equipment or system manufacturer only, and it will tell you how to install, use and maintain your LINAK electronics. The manufacturer of the end product has the responsibility to provide a User Manual where relevant safety information from this manual is passed on to the end user.

We are convinced that your LINAK system will give you many years of problem-free operation.

Before our products leave the factory they undergo full function and quality testing. Should you, nevertheless, experience problems with your systems, you are always welcome to contact your local dealer.

LINAK subsidiaries and some distributors situated all over the world have authorised service centres, which are always ready to help you.

LINAK provides a warranty on all products.

This warranty, however, is subject to correct use in accordance with the specifications, maintenance being done correctly and any repairs being carried out at a service centre, which is authorised to repair LINAK products.

Changes in installation and use of LINAK systems can affect their operation and durability. The products are only to be opened by authorised personnel.

This User Manual has been written on the basis of the present technical knowledge. LINAK is constantly keeping the information updated and we therefore reserve the right to carry out technical modifications.

LINAK A/S

Valid for

This User Manual is valid for the following products:

| | |
|-----------------------|--|
| Actuators: | LA20 Inline, LA23 DESKLINE®, LA23 MEDLINE® CARELINE® TECHLINE®, LA23 IC, LA27, LA28, LA28 Compact, LA29, LA30, LA31, LA34, LA40 HOMELINE®, LA40 MEDLINE® CARELINE®, LA44 |
| Columns: | BL1, LC3 |
| Control boxes: | CA30, CA40, CA63, CB6, CB6P2, CB7, CB8A, CB8-T, CB9 HOMELINE®, CB9 CARELINE® and CB9 CARELINE® Basic, CB20, CBR1, CO53, CO61, CO65, CO71, OPS, PJ2 |
| Controls: | ABL, ACC, ACK, ACL, ACO, ACOM, DPH Medical, FPP, FS, FS3, HB30, HB70, HB80, HB100, HB190, HB200, HD80, HD80 JUMBO, HL70, HL80, LS, LSD |
| JUMBO systems: | BAJ, BAJL Li-Ion, CBJ1/2, CBJ-Care, CBJ-Home, COBO, CH01 2 nd generation, CHJ2, MBJ1/2/3 |
| Accessories: | BA16 Lead acid, BA18, BA19 Lead acid, BA21 Li-Ion, CS16, DJB, Massage Motor Medical, MJB2, MJB5 Plus, Simulator tool, SLS, Under Bed Light, Under Bed Light 2, QLC12 |
| LIFT: | CAL40, BAL40, CHL40, COL50, BAL50, CHL50, |

Important information

LINAK® products, within the scope of this manual, are not classified as medical electrical equipment or systems, nor do they fall within the scope of the EU Medical Device Directive/Regulation or other similar national regulations. The products are components to be built into a piece of medical electrical equipment by a manufacturer.

To support the assessment and certification task of the complete medical electrical equipment or system worldwide, LINAK provides certification, on a component level, according to the IEC 60601-1, (Medical electrical equipment – Part 1: General requirements for basic safety and essential performance) as IEC-certificate and listed as recognised components by NRTL (Nationally Recognized Testing Laboratories).

Description of the various signs used in this manual:



Warning

Failure to comply with these instructions may result in accidents involving serious personal injury.



Recommendation

Failing to follow these instructions can result in product damage.

Please read the following safety information carefully:

It is important for everyone who is to connect, install or use the systems to have the necessary information and access to this User Manual.

Please be aware that LINAK has taken precautions to ensure the safety of the actuator system. The manufacturer/OEM is responsible for the overall approval of the complete application.

LINAK recommends to use the actuators in push applications rather than pull applications.

LINAK actuators are **not** to be used for repeated dynamic push-to-pull movements.

For general pull applications or repeated dynamic push-to-pull movements in the application, please contact LINAK A/S if in doubt.

LINAK® actuators and electronics generally fall outside the IEC 60601-1 definition of applied parts and are not marked as such.

However, assessing the risk whether actuators and electronics can unintentionally come into contact with the patient, determines that they are subject to the requirements for applied parts. All the relevant requirements and tests of the standard are carried out as part of the IEC CB-Scheme assessment.

RF transmitter / receiver properties:

Some LINAK products emit RF-power by intention for communication purposes.

Frequency band of transmission: 2402 MHz - 2480 MHz

Type: BLUETOOTH Low Energy BLE 4.2

Modulation: GFSK

Maximum Effective Radiated Power (ERP): 10 dBm

FCC and IC Statements

For RF-emitting products (e.g. BLUETOOTH®, Wi-Fi) intended to be used on the North American continent, the following applies:

FCC statement

NOTE: This equipment has been tested and found to comply with the limits for a Class B digital device, pursuant to part 15 of the FCC Rules. These limits are designed to provide reasonable protection against harmful interference in a residential installation. This equipment generates uses and can radiate radio frequency energy and, if not installed and used in accordance with the instructions, may cause harmful interference to radio communications. However, there is no guarantee that interference will not occur in a particular installation. If this equipment does cause harmful interference to radio or television reception, which can be determined by turning the equipment off and on, the user is encouraged to try to correct the interference by one or more of the following measures:

- Reorient or relocate the receiving antenna.
- Increase the separation between the equipment and receiver.
- Connect the equipment into an outlet on a circuit different from that to which the receiver is connected.
- Consult the dealer or an experienced radio/TV technician for help

Changes or modifications not expressly approved by the party responsible for compliance could void the user's authority to operate the equipment.

This device complies with Part 15 of the FCC Rules. Operation is subject to the following two conditions:

- (1) this device may not cause harmful interference, and
- (2) this device must accept any interference received, including interference that may cause undesired operation.

IC statement

This device contains licence-exempt transmitter(s)/receiver(s) that comply with Innovation, Science and Economic Development Canada's licence-exempt RSS(s). Operation is subject to the following two conditions:

- (1) This device may not cause interference.
- (2) This device must accept any interference, including interference that may cause undesired operation of the device.

L'émetteur/récepteur exempt de licence contenu dans le présent appareil est conforme aux CNR d'Innovation, Sciences et Développement économique Canada applicables aux appareils radio exempts de licence. L'exploitation est autorisée aux deux conditions suivantes :

- (1) L'appareil ne doit pas produire de brouillage;
- (2) L'appareil doit accepter tout brouillage radioélectrique subi, même si le brouillage est susceptible d'en compromettre le fonctionnement.

Output ratings:

Nominal values:

On LINAK control boxes, battery boxes and power supply marking plates, the nominal output voltage at a certain load for a certain product may be stated.

Depending on product and load, this value may vary significantly due to construction.

The expected output voltage may for instance vary depending on product and load within a range from approximately 20 V DC to approximately 50 V DC for a product with a nominal output voltage of 24 V DC due to the construction.

When combining LINAK control boxes, battery boxes and power supplies with other LINAK components, compatibility is ensured. When combining LINAK control boxes, battery boxes or power supplies with third party products, special precautions may be taken. In this case, contact LINAK.

Classification:

The equipment is not suitable for use in the presence of a flammable anesthetic mixture with air or with oxygen or nitrous oxide.



Warning

Electromagnetic compatibility - general

LINAK® actuator systems bear the CE marking as an attestation of compliance with the EMC Directive 2014/30/EU. The systems are designed to meet all requirements of applicable standards and have been tested to meet IEC 60601-1-2 requirements.

Emission:

LINAK Actuator Systems are CISPR 11, Group 1, Class B products, comply with IEC 61000-3-2, Class A and IEC 61000-3-3 unless stated otherwise in the relevant section of this document.

Immunity:

Test levels are according to Professional Healthcare Facility and Home Healthcare Facility Environment.

Electromagnetic phenomena are evaluated on a system level, with the actuator connected to a LINAK control box and accessories.

LINAK always recommends to perform verification tests on the final medical device.



Warning

Electromagnetic compatibility – third party components

Use of accessories, transducers and cables other than those specified by LINAK could result in increased electromagnetic emissions or decreased electromagnetic immunity of the actuator system and result in improper operation.



Warning

Electromagnetic compatibility – interference with other equipment in general

Use of the actuator system adjacent to or stacked with other equipment should be avoided as this could result in improper operation. If such use is necessary, the actuator system and the other equipment should be observed to verify that they are operating properly.

If the user notes unusual behavior of the actuator system, in particular if such behaviour is intermittent and associated with the standing right next to mobile phones, microwaves and radio broadcast masts, this could be an indication of electromagnetic interference.

If such behaviour occurs, try to move the actuator system further away from the interfering equipment.



Warning

Electromagnetic compatibility – interference with other equipment, RF communications

Portable RF communication equipment (including peripherals such as antenna cables and external antennas) should be used at a distance no closer than 30 cm (12 inches) to any part of the actuator system. This also applies to cables specified by the manufacturer. Otherwise, a performance degradation of this equipment could result.



Warning

If the actuator or lifting column is used for pull in an application where personal injury can occur, the following is valid:

The medical device manufacturer is responsible for the incorporation of a suitable safety arrangement, which will prevent personal injury from occurring in case of actuator failure.



Warning

Note that during construction of applications, in which the actuator is to be fitted, there must be no possibility of personal injury, for example the squeezing of fingers or arms.



Warning

The plastic parts in the system cannot tolerate cutting oil.



Warning

Assure free space for movement of the application in both directions to avoid a blockade.

















Warning

The application and actuators are only to be operated by instructed personnel.



Warning

In applications with spline function, the blockage by an obstacle when the application is moving inwards, the removal of the obstacle will cause the load to drop until the spindle hits the nut.

-  **Warning**
Do not turn the outer tube.
-  **Warning**
Do not use chemicals.
-  **Warning**
Inspect the actuator system regularly for damage and wear.
-  **Warning**
Do not expose LINAK actuator system components to high intensity ultraviolet radiation disinfection lamps. This may damage the enclosure, supporting parts and cables.
-  **Warnings**
LINAK® actuators and electronics are not designed for use within the following fields:
- Planes and other aircrafts
 - Explosive environments
 - Nuclear power generation
-  **Warning**
If faults are observed, the products must be replaced.
-  **Warning**
A LINAK control box, actuator and accessory component must, in the final application, be placed where it is not exposed to any impact. This is to prevent damage if a passer-by accidentally hits it with an object or when cleaning the floor with a broom or a mop. On a medical bed e.g. this might be underneath the mattress support platform. If necessary to mitigate this risk, additional protection might be required.
-  **Warning**
Handle batteries carefully. Do not short circuit the battery.
-  **Warning**
Avoid continuous battery discharge when the medical device is not in use, as this may cause lead sulphate formation, which, if left in this state for too long, will irreversibly damage the battery.
-  **Warning**
To avoid unintended movement, prevent foreign objects or persons from unintentionally activating a footswitch or a hand control at any time, for instance during normal use or maintenance.
-  **Warning**
LINAK battery packs may emit flammable gases. Do not expose the battery packs to fire or equipment that emits sparks. Moreover, do not store the battery in a closed environment or incorporate it into a closed structure of an enclosure as this may cause an explosion, fire, equipment damage, or injury.
-  **Warning**
Handle tools carefully and do not wear jewelry when handling batteries. A short-circuit of the battery terminals can cause burn injuries, damage or trigger explosions.
-  **Warning**
Only connect LINAK batteries to compatible chargers.
-  **Warning**
LINAK battery packs contain toxic substances. If the internal battery fluid leaks out and gets onto skin or clothing, make sure it is washed off with clean water. Moreover, if the fluid gets into the eyes, rinse them immediately with clean water and seek medical assistance.
-  **Warning**
Do not use or store LINAK battery packs in places where the ambient temperature exceeds 50 °C, such as inside a hot automobile, in direct sunlight, or in front of a stove or a source of intense heat. Doing so can shorten the battery life, lower its performance level, cause the battery to leak fluid, explode, cause fire, or be damaged.



Recommendation

The duty cycle printed on the actuator system label must always be respected. If exceeded, there is a risk that the actuator system is damaged. Unless otherwise specified on the label, the duty cycle is max. 10%, max. 2 min. in use followed by 18 min. not in use.



Recommendation

Important information regarding lithium ion batteries

Li-Ion batteries are moving in the direction of minimising the physical size and at the same time increasing the capacity. This gives a very size-effective battery but with a high concentration of energy within a small physical size. It also increases the risk of thermal runaway (see note below) due to internal short circuits.

The general use of Li-Ion batteries has increased and the inherent risk of thermal runaway has led to stricter rules within the transport industry, specifically air transport, with tightened restrictions placed on the quantity to be transported and handled, and on the storage of specific products moving via air.

The OEMs and end users must recognise that although safe to use, there is still a very small risk of thermal runaway in a Li-Ion cell. The size of that risk could be as little as 1PPM or even less.

LINAK® currently bases our Li-Ion battery design on industry proven cell types that have a proven history (e.g. electric cars). The use of well-proven cell technology reduces the risk of thermal runaway, but it does not eliminate it. LINAK has completed activities to reduce this risk and the complete battery package is UL approved.

An external, internationally recognised expert has also reviewed the design to ensure that it is in accordance with the recommendations. Further to that, LINAK only uses cells from well-recognised manufacturers.

When using Li-Ion batteries, LINAK recommends that the customer carries out a proper risk analysis for their application. The risk analysis must also focus on non-mounted products that can be in direct contact with flammable materials.

LINAK Li-Ion batteries have no more risk of thermal runaway compared to other Li-Ion cells from well-recognised manufacturers within the market. Therefore, it is clear that LINAK cannot take responsibility for any failures that occur due to Li-Ion battery inherent failures.

If any of the Li-Ion batteries built into LINAK products is found to be defective under warranty, LINAK will provide a new product to the OEM.

LINAK explicitly disclaims all other remedies. LINAK shall not in any event be liable under any circumstances for any special indirect punitive incidental or consequential damages or losses arising from any incident related to the inherent risk of thermal runaway in the Li-Ion cell and any use of LINAK products. Moreover, LINAK explicitly disclaims lost profits, failure to realise expected savings, any claim against our customers by a third party, or any other commercial or economic losses of any kind, even if LINAK has been advised of the possibility of such damages or losses.

Note: *'Thermal runaway' is overheating of a cell and it could lead to a small fire and smoke from the cell.*

Transportation

The lithium ion batteries must be packed and transported in accordance with applicable regulations. Always ask your local transportation provider how to handle the transportation of lithium ion batteries.

Please see the general assembly instructions and the mounting section for detailed information.

General assembly instructions

Please read the following safety information carefully. Ensure that all staff who are to connect, mount, or use the actuator system are in possession of the necessary information and that they have access to these assembly instructions.

Persons who do not have the necessary experience or knowledge of the product/products should not use the product/products. Moreover, persons with reduced physical or mental abilities must not use the product/products, unless they are under surveillance or they have been thoroughly instructed in the use of the equipment by a person who is responsible for the safety of these persons. Moreover, children must be under surveillance to ensure that they do not play with the product.



Warnings

Failure to comply with these instructions may result in accidents involving serious personal injury.

- If there is visible damage on the product it should not be installed.
- If the actuator system makes unusual noise or smells, switch off the mains voltage immediately.
- The products must only be used in an environment that corresponds to their IP protection class.
- The cleaners and disinfectants must not be highly alkaline or acidic (pH value 6-8).
- Irrespectively of the load, the duty cycle stated on the product label must NOT be exceeded.
- The control box must only be connected to the voltage stated on the label.
- Systems not specified for pull must only be used in push applications.
- Fastening screws and bolts must be tightened correctly.
- Specifications on the product label must under no circumstances be exceeded.
- NOT TO BE OPENED BY UNAUTHORISED PERSONS.
- Only use the actuator within specified working limits.
- Be aware that during the design of medical devices, the risk of personal injury (for instance squeezing of fingers or arms) must be minimised.
- If irregularities are observed, the actuator must be replaced.



Failing to follow these instructions may result in actuator system damage:

- Prior to assembly/disassembly, ensure that the following points are observed:
 - The actuator system is not in operation.
 - The mains current supply is switched off and the plug has been pulled out.
 - Actuators are free from loads that could be released during this work.
- Prior to operating the actuator system, check the following:
 - Actuator system components are correctly mounted as indicated in the relevant user instructions.
 - The equipment can be operated in its entire intended range of movement.
 - Ensure that the load-supporting bolts can withstand the wear.
 - Ensure that the load-supporting bolts are secured safely.
- During operation:
 - Listen for unusual sounds and watch out for uneven movement. Stop the actuator system immediately if anything unusual is observed.
 - Do not sideload the actuator.
 - Do not step on or kick the actuator.
- When the equipment is not in use:
 - Switch off the mains supply or pull out the plug in order to prevent unintentional operation.
- Note:
 - When changing the cables on a LINAK actuator system, it is important that this is done carefully in order to protect the plugs and pins. Please ensure that the plug is in the right location and properly inserted before the cable lid is mounted.

DECLARATION OF INCORPORATION OF PARTLY COMPLETED MACHINERY

LINAK A/S
Smedevænget 8
DK - 6430 Nordborg

LINAK A/S hereby declares that **LINAK DESKLINE®** products, characterised by the following models and types:

| | |
|-------------------|---|
| Control Boxes | CBD6S |
| Linear Actuators | DB5, DB6, DB12, DB14, LA23, LA31 |
| Lifting Columns | DL1A, DL2, DL4S, DL5, DL6, DL7, DL8, DL9, DL10, DL11, DL12, DL14, DL15, DL16, DL17, DL18, DL19, DL20, DL21 , BASE1 |
| Desk Panels | DPA, DPB, DPH, DPF, DPG, DPT, DP, DP1CS |
| Wireless Controls | HB10, HB20, RFRL |
| Accessories | BA001, BLE2LIN, DS1, DF2, Kick & Click, SLS, SMPS001, SMPS002, SMPS006, USB2LIN |

LINAK A/S hereby declares that **LINAK HOMELINE®** products, characterised by the following models and types:

| | |
|-------------------|--|
| Control Boxes | CBH Advanced, CBH Basic |
| Linear Actuators | LA10, LA18, LA27, LA29, LA31 HOMELINE, LA40 HOMELINE |
| Dual Actuators | TD3, TD4, TD5 |
| Controls | HB10 |
| Wireless Controls | BP10 , HB10, HC05, HC10, HC20, HC30, HC40 |
| Accessories | CP001, CP002, BLE2DC , BLE2LIN, DC CONNECTOR, LED Lightbox, LED Light Rail, Massage Motor, SMPS001, SMPS002, SMPS006, WiFi2LIN |

LINAK A/S hereby declares that **LINAK MEDLINE® & CARELINE®** products, characterised by the following models and types:

| | |
|------------------|---|
| Control Boxes | CA30, CA40, CA63, CAL40 , CB6, CB6P2, CB8, CB9, CB20, CBJ, CBJ-Care, CBJ-Home, CO53, CO61, CO65, CO71, COL50 , OPS, PJ2, PJB4 |
| Linear Actuators | LA20, LA23, LA27, LA28, LA29, LA30, LA31 MEDLINE CARELINE, LA34, LA40 MEDLINE CARELINE, LA44 |
| Lifting Columns | BL1, LC3 |
| Controls | ABL , ACC, ACK, ACO, ACOM, ACL, DP, DPH, FS, FS3, FPP, HB30, HB70, HB80, HB100, HB190, HB200, HD80, HL70, HL80 |
| Accessories | BA16, BA18, BA19, BA21, BAJ, BAJL, BAL40, BAL50 , CH01, CHJ2, CHL40, CHL50 , COBO, DJB, EBC, MJB2, MJB5 Plus , SMPS19, SLS, Massage Motor, QLCI2, UBL, UBL2 |

LINAK A/S hereby declares that **LINAK TECHLINE®** products, characterised by the following models and types:

| | |
|------------------|--|
| Linear Actuators | LA12, LA14, LA23, LA25, LA30, LA33, LA35, LA36, LA37 |
| Accessories | FMB |

comply with the following parts of the Machinery Directive 2006/42/EC, ANNEX I, Essential health and safety requirements relating to the design and construction of machinery:

1.5.1 Electricity supply

The relevant technical documentation is compiled in accordance with part B of Annex VII and this documentation or part hereof will be transmitted by post or electronically to a reasoned request by the national authorities.

This partly completed machinery must not be put into service until the final machinery into which it is to be incorporated has been declared in conformity with the provisions of the Machinery Directive 2006/42/EC where appropriate.

Nordborg, 2021-03-22



LINAK A/S
John Kling, B.Sc.E.E.
Certification and Regulatory Affairs
Authorized to compile the relevant technical documentation

1. System description:

Usage/type of applications:

LINAK® actuators, lifting columns and electronics have been developed for use in all places where a linear movement is required.

LINAK products can for example be used for:

- Adjustment of beds
- Patient hoists within the care and hospital sector
- Adjustment of dentist chairs/gynaecological chairs
- Etc.

The principles of a LINAK system are as follows:

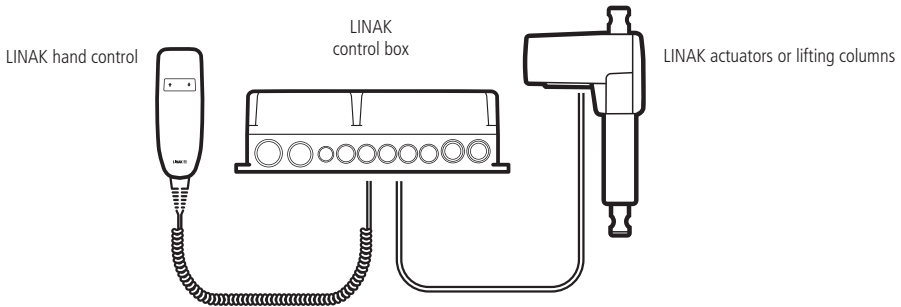

Attention should be paid to the following:

- All detachable connections between components must be locked by the cable locking mechanism - when applicable.
- All cables must be mounted in such a way that they are not trapped or exposed to tension or sharp objects when the application is moved in different directions.



Recommendation

It is recommended to have options like quick release, manual lowering or similar built into the system in case of power loss or system failure or if movement of the system is critical. After service it is recommended to test the system for correct functionality before it is put back into operation.

Electrostatic discharge (ESD)

LINAK® considers ESD to be an important issue and years of experience have shown that equipment designed to meet the levels specified in standards might be insufficient to protect electronic equipment in certain environments.

1. Handling and mounting electrostatic discharge sensitive devices (ESDS devices).

- Handling of sensitive components shall only take place in an ESD Protected Area (EPA) under protected and controlled conditions.
- Wrist straps and/or conductive footwear (personal grounding) shall always be used when handling ESDS devices.
- Sensitive devices shall be protected outside the EPA by the use of ESD protective packaging.

2. Responsibility LINAK/customer.

- ESDS devices must under no circumstances, during transport, storage, handling, production or mounting in an application, be exposed to harmful ESD.
- LINAK can only guarantee the lifetime of ESDS devices if they are handled in the same way from production at LINAK A/S until they are mounted in the manufacturer's application. It is therefore important that the ESDS devices are not removed from the ESD protected packaging before they are physically within the EPA area at the customer premises.

Please refer to EN61340 for further information:

EN61340-5-1, Electrostatics - Protection of electronic devices from electrostatic phenomena - General requirements

EN61340-5-2, Electrostatics - Protection of electronic devices from electrostatic phenomena - User guide

Fundamental actuator construction

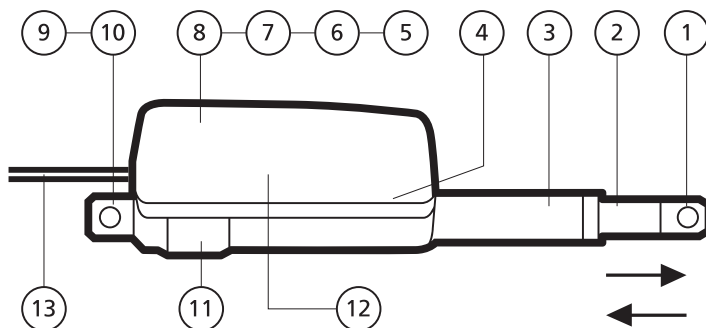

1. Piston rod eye

2. Piston rod

3. Location of mechanical splines

4. Location of brake

5. Motor

6. Motor with optical switch

7. Motor with potentiometer

8. Motor with reed-switch

9. Back fixture

10. Back fixture with electrical splines

11. Quick release mechanism

12. Transmission between motor and spindle

13. Cable for connection to DC by means of plug via control box

General Warranty periods

These are general warranty periods. Some segments may have special warranty agreements depending on application types. Ex. TECHLINE solar applications. And some customers have Quality agreements with LINAK. These are to be handled accordantly.

MEDLINE® and CARELINE®:

LINAK® provides 5 years (60 months) warranty on MEDLINE and CARELINE products used in beds and medical applications. If MEDLINE® and CARELINE® products are used in other applications, they will be covered by 1½ years (18 months) warranty. Batteries are covered by a specific product warranty of 12 months.

HOMELINE®:

LINAK® provides 3 years (36 months) warranty on HOMELINE actuator systems used in comfort furniture. If these products are used in other applications, they will be covered by 1½ years (18 months) warranty. Batteries are covered by a specific product warranty of 12 months.

DESKLINE®:

LINAK® provides 5 years (60 months) warranty on all DESKLINE® products produced after 01.05.2015. Products produced before 01.05.2015 will still have a 36 months warranty. If these products are used in other applications, they will be covered by 1½ years (18 months) warranty. Batteries are covered by a specific product warranty of 12 months.

TECHLINE®:

LINAK® provides 1½ years (18 months) warranty on TECHLINE products. Batteries are covered by a specific product warranty of 12 months.

General information:

External products that are not manufactured by LINAK A/S: 12 months are added to the warranty period, for instance for transportation and stocking. Relabelling of these products only takes place, if the production date exceeds one year from the date of dispatch to the customer.

If there is any doubt whether returned products are covered by the warranty, they are covered by the warranty. Please use the date of the control box or actuator as reference, if possible.

Subsidiaries are allowed to offer additional warranty periods.

IP Protection degree

The products can be cleaned as described in the following according to their IP protection stated on the product label.

The IP code specifies the protection degree provided by the enclosures. For most products, only the protection against ingress of water (second characteristic numeral) is specified, ingress of solid foreign objects or dust (first characteristic numeral) is not specified and therefore replaced by the letter X in the code.

| IP protection | Cleaning instructions |
|---|--|
| IPX0 | Clean with a damp cloth |
| IPX1 | Clean with a damp cloth |
| IPX2 | Clean with a damp cloth |
| IPX3 | Clean with a damp cloth |
| IPX4 | Clean with a damp cloth |
| IPX5 | Wash with a brush and water, but not water under pressure |
| IPX6 | Wash with a brush and water. The water can be under pressure, but the system must not be cleaned directly with a high pressure cleaner. Max. 20 °C |
| IPX6 Washable according to IEC 60601-2-52 | Clean by the use of wash tunnels according to IEC 60601-2-52 |
| IPX6 Washable DURA™ | Clean by the use of wash tunnels according to IEC 60601-2-52, extended washing cycle test |

To avoid degreasing of the piston rod, the actuator should be retracted to minimum stroke and without load before washing.



Warning

The systems must not be sprayed directly with a high pressure cleaner.



Warning

Interconnecting cables must remain plugged in during cleaning to prevent water ingress.



Warning

Cleaning with a steam cleaner is not permitted.

IPX6 Washable

LINAK washable products frequently undergo a fully regulated washing test.

At LINAK, "IPX6 Washable" means that the products conform only to this test.

Reference: The standard IEC 60601-2-52-2010, which includes special demands to fundamental safety and relevant functional characteristics for hospital beds.

The demands for the washing process are described in the German "Maschinelle Dekontamination" from the organisation AK-BWA (Arbeitskreis Bettgestell- und Wagen-Dekontaminationsanlagen).

Description: At LINAK, the washing test takes place in an instrument washing machine, which is fitted and programmed in such a way that it duplicates the process used in a typical hospital installation for the cleaning of beds and other medical equipment.

During the test, the products are exposed to both thermal and chemical effects.

To avoid degreasing of the piston rod, the actuator should be retracted to minimum stroke and without load before washing.

Preparation: As plastic materials to a larger or lesser degree change characteristics and shape with time and climatical exposure, an ageing of the products is carried out first. The conditions for ageing are 65 °C +/- 2 °C in normal dry air for 10 days followed by a minimum of 16 hours at room temperature before the washing process starts.

Procedure: Ageing for 10 days at 65 °C.

Rest for a minimum of 16 hours.

The washing process proceeds in the following way:

- Wash with Alkaline detergent for 2 min. with 70 °C hot water in the tank
- Rinse with neutral rinsing product for 20 sec. with 65 °C hot water in the tank
- Drying and cooling for 10 min. in open air at normal room temperature of approx. 20 °C
- The washing process is repeated 50 times

Water: Degree of hardness, no more than 5° dH and no demineralised water.

Detergents: LINAK recommends the following products:

- Sekumatic FDR or FRE from Ecolab
- Neodisher Dekonta from Dr. Weigert
- Thermosept NDR from Schülke or similar with a pH-value of 5 - 8 and in a concentration of 0.5 %

Rinsing aids: LINAK recommends the following products:

- Sekumatic FKN from Ecolab
- Neodisher BP or TN from Dr. Weigert
- Thermostept BSK from Schülke or similar with a pH-value of 5 - 8 and in a concentration of 0.2 %.

Demands to chemicals:

- They must not contain caustic solutions
- They must not change the surface structure or adhesive properties of the plastic
- Must not break down grease

LINAK washing profile according to IEC 60601-2-52

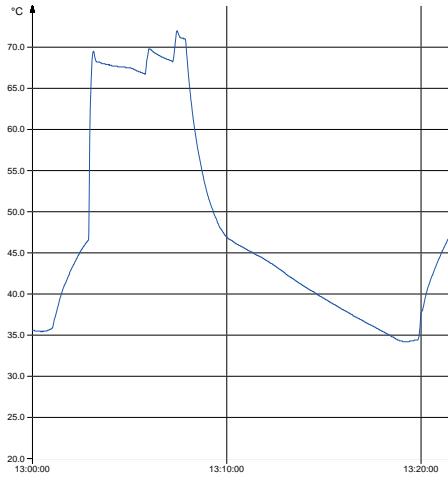

LINAK washing machine



Cable Wash

Before the washing procedure starts!

In order to maintain the flexibility of the cables, it is important that the cable is placed in such a way that the cable's own weight does not strain the coil during the washing process.

This can be done by placing the cable ON the bed or another form of support for the cable.

Please see the examples in the picture to the right.



Maintenance

Valid for all LINAK products

- LINAK® products must be cleaned at regular intervals
- Inspect for malfunction, mechanical damage, wear and cracks. Worn-out parts must be replaced
- Inspection/maintenance intervals may be defined by the medical device manufacturer
- LINAK products are closed units and require no internal maintenance
- Only type IPX6, IPX6 Washable and IPX6 Washable DURA™ are waterproof
- LINAK products must be IPX6 Washable and IPX6 Washable DURA™ when cleaning in wash tunnels
- **O-rings:** When individual parts are replaced in a LINAK IPX6, IPX6 Washable or IPX6 Washable DURA™ system, the O-rings must be replaced at the same time on all parts
On all products where replaceable cables or fuses have been dismantled or replaced, the O-ring must be replaced, and the O-rings and the receptacle insert must be greased with an acid-free Vaseline.

Valid for all LINAK actuators and lifting columns

- Actuators/lifting columns must be inspected at attachment points, wires, piston rod, enclosure, and plugs, and it must be checked that the actuators/lifting columns function correctly
- To ensure that the pregreased inner tube remain lubricated, the actuator must only be washed when the piston rod is fully retracted

Valid for all LINAK control boxes and hand controls

- Electronics must be inspected at attachment points, wires, enclosure, and plugs
- Inspect the connections, cables, enclosure, and plugs, and check for correct functioning
- The control box is sealed and maintenance-free

Environmental conditions

| Operating, storage and transport | |
|---|--|
| Operating Temperature Relative humidity Atmospheric pressure | 5 °C to 40 °C 20% to 80% - non-condensing 700 to 1060 hPa (Rated to be operated at an altitude ≤ 3000 m) |
| Storage Temperature Relative humidity Atmospheric pressure | -10 °C to +50 °C 20% to 80% - non-condensing 700 to 1060 hPa (Rated to be stored at an altitude ≤ 3000 m) |
| Transport Temperature Relative humidity Atmospheric pressure | -10 °C to +50 °C 20% to 80% - non-condensing 700 to 1060 hPa (Rated to be transported at an altitude ≤ 3000 m) |
| If the actuator is assembled in the application and is exposed to push or pull during transportation, the actuator can be damaged. Do not drop an actuator or otherwise damage the housing during disassembly or transportation. We do not recommend to use an actuator which has been damaged. | |





















Valid if nothing otherwise is stated under the specific products in a later section.

Insulation class

LINAK® control boxes are available in insulation class 1 and insulation class 2.

Key to symbols

The following symbols are used on the LINAK product labels:

| | | | |
|---|---|--|--|
|  | IEC 60417-5172: Class II equipment |  | Recycle |
|  | Product with a thermofuse |  | Recognised Component mark for Canada and the United States |
|  | IEC 60417-5957: For indoor use only |  | PSE mark |
|  | IEC 60417-5222: Safety isolating transformer, general |  | Compliance to all relevant EC directives |
|  | IEC 60417-5840: Patient part of type B |  | China Pollution control mark (also indicates recyclability) |
|  | IEC 60417-5019: Protective earth; protective ground |  | Regulatory compliance mark: The Australian Safety/EMC Regulations |
|  | IEC 60417-5002: Positioning of cell |  | Alternating current |
|  | ISO 7000-0434A: Caution, consult accompanying document |  | Direct current |
|  | ISO 7000-1641 Operating instructions |  | Reduced ETL recognised component mark for Canada and the United States. X: The mark is always accompanied by a control number of 6 or 7 figures. For complete description, see ETL marking on next page. |
|  | Electronics scrap | | |
|  | Electronics scrap | | |

ETL marking

Due to space limitations, the complete ETL marking demands are not represented on the marking plates.
The full ETL recognised component markings are shown here:



C/N 120690
Conforms to ANSI/AAMI Std. E560601-1
Cert. to CSA Std. C22.2 No. 60601-1



C/N 4008004
Conforms to ANSI/AAMI Std. E560601-1
Cert. to CSA Std. C22.2 No. 60601-1



C/N 4008838
Conforms to ANSI/AAMI Std. E560601-1
Cert. to CSA Std. C22.2 No. 60601-1



C/N 9901916
Conforms to ANSI/AAMI Std. E560601-1
Cert. to CSA Std. C22.2 No. 60601-1



C/N 4008005
Conforms to ANSI/AAMI Std. E560601-1
Cert. to CSA Std. C22.2 No. 60601-1



C/N 4008671
Conforms to ANSI/AAMI Std. E560601-1
Cert. to CSA Std. C22.2 No. 60601-1



C/N 4008003
Conforms to ANSI/AAMI Std. E560601-1
Cert. to CSA Std. C22.2 No. 60601-1



C/N 4008623
Conforms to ANSI/AAMI Std. E560601-1
Cert. to CSA Std. C22.2 No. 60601-1



C/N 4009507
Conforms to ANSI/AAMI Std. E560601-1
Cert. to CSA Std. C22.2 No. 60601-1

Mounting

Actuator:

Do not use any other screws for the mounting brackets than those recommended by LINAK®. If longer screws are used, they will come into contact with the inner parts of the actuator. This will result in an irregular operation or even damage the actuator.

During mounting, the actuator must always be:

- Fixed to protect it against torque and bending. **See Figure 2 on the next page.**
- Fixed so that it is restrained, but free to move on its mountings. **See Figure 3 on the next page.**
- Fixed in brackets, which can take up the torque reaction. **See Figure 3 on the next page.**
- Mounted at right angles so that the right angle requirement is observed. **See Figure 4 on the next page.**
- Mounted with correct bolt dimension.
- Mounted with bolts and nuts made of high quality steel grade (for example 10.8). No thread on bolts inside the back fixture or the piston rod eye.
- Bolts and nuts must be protected from being able to fall out.
- Inspect the actuator for damage before mounting. A damaged actuator must not be mounted. Check for instance for damaged packaging.
- Do not use a too high torque when mounting the bolts for the back fixture or the piston rod eye

Control boxes:

- The mounting screws on the control box must be tightened with a maximum torque of 1 Nm
- The mounting surface to which the control box is attached should have a surface evenness better than ± 0.5 mm.
- Systems must not be installed/deinstalled while in operation.
- Control boxes with a wet alarm must be mounted as shown on figure 5 on the next page.
- Nuts and bolts must be made of steel.
- Nuts and bolts must be tightened securely.
- For control boxes with earth connection (Class 1), the nut must be tightened with a torque of 1 - 1.2 Nm.



Cables:

It is important to remove the transport plastic bag before using the cable.

Accessories:

The mounting screws on accessories must be tightened with a maximum torque of 1 Nm

- The mounting surface to which the accessory is attached should have a surface evenness of more than ± 0.5 mm
- Systems must not be installed/deinstalled while in operation
- Nuts and bolts must be made of steel
- Nuts and bolts must be tightened securely

Controls:

The mounting screws on the controls must be tightened with a maximum torque of 1 Nm

- The mounting surface to which the accessory is attached should have a surface evenness of more than ± 0.5 mm
- Systems must not be installed/deinstalled while in operation
- Nuts and bolts must be made of steel
- Nuts and bolts must be tightened securely

For further instructions regarding mounting, see the data sheet for the individual product or in chapter 5, 6 or 8 in this manual.

Figure 2

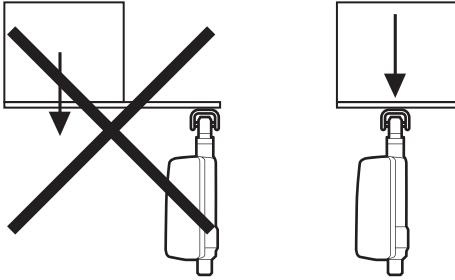

Figure 3

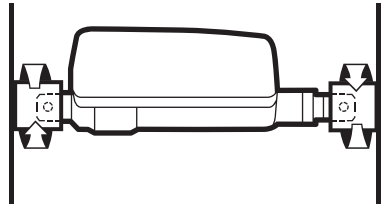

Figure 4

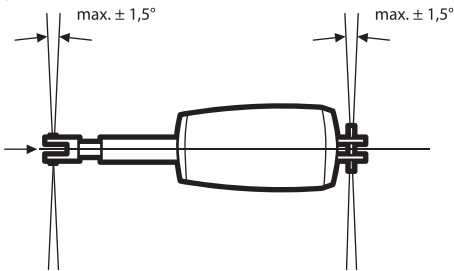
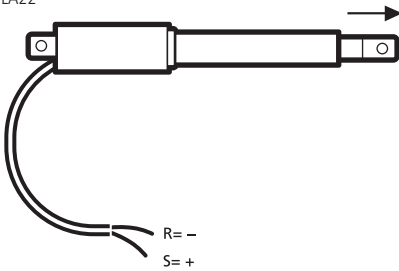
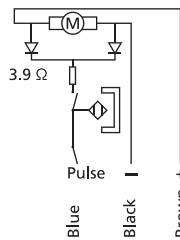
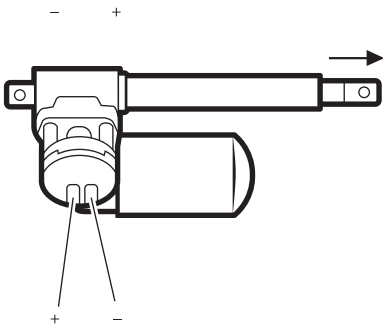

Figure 6

1) LA22



3) LA30 and 30S



| | | |
|-------|-------|-----------|
| Brown | Black | |
| + | - | Out going |
| - | + | In going |

Figure 6

4) LA12

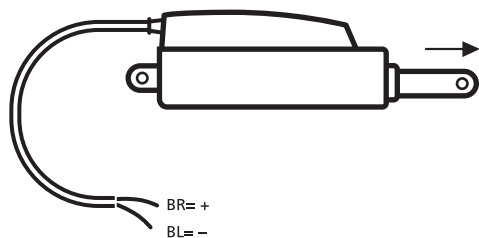

5) LA30, LA30S, LA32 and LA34 with potentiometer

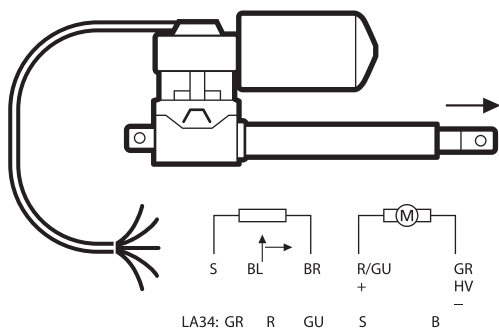

Colour codes:

| | |
|----|--------|
| S | Black |
| BR | Brown |
| R | Red |
| O | Orange |
| GU | Yellow |
| G | Grey |
| BL | Blue |
| V | Purple |
| GR | Green |
| HV | White |

6) LA30, LA30S and LA32 with optical encoder

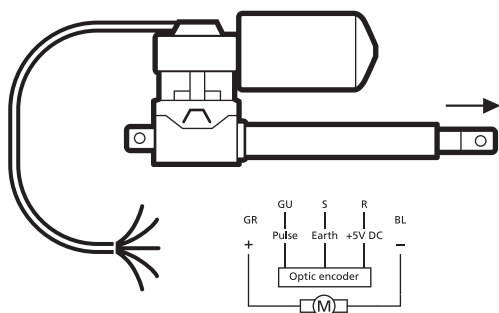
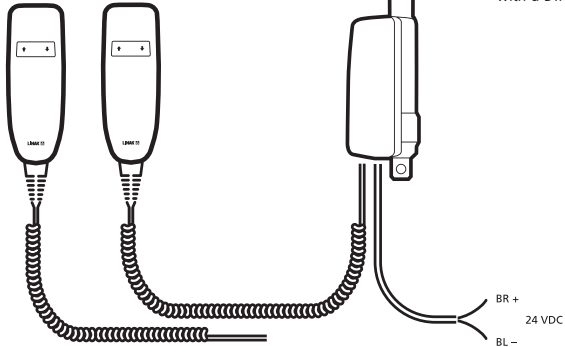

Figure 6

7A-B) LA28/28S/32 with CS28/28S/32 - PC-board version A and B

Version A

LINAK hand control HB is connected with a telephone plug



Version B

LINAK hand control HB is connected with a DIN plug

7C) LA28/28S/32 with CS28/28S/32 - PC-board version C

Version C

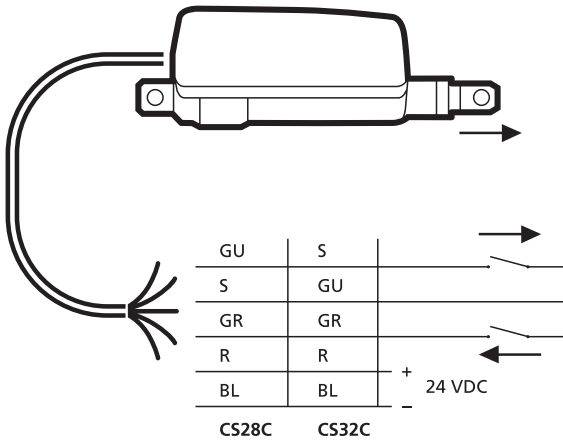

8) LA28, LA28S, LA32 with reed-switch and LA34 with pulse system

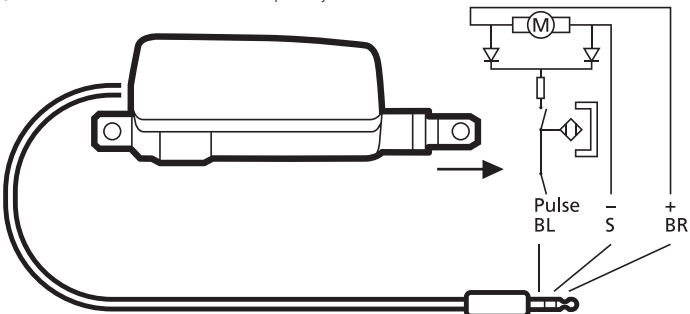
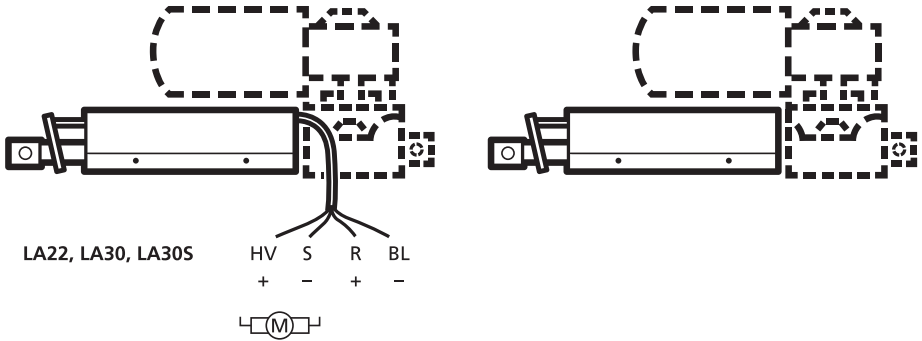
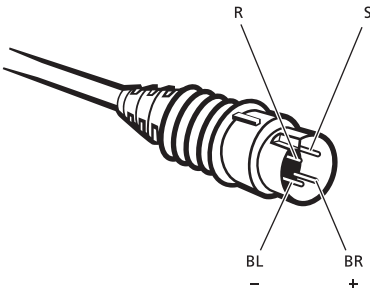

Figure 6

9) LSD



10) LA31, LA34 with electronic pulse coder (reed-switch)



11) LA31 TECHLINE

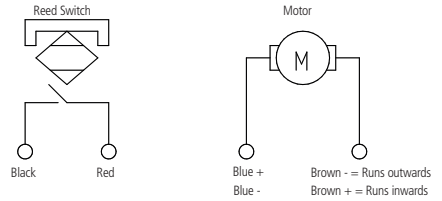

12) LA12 PLC

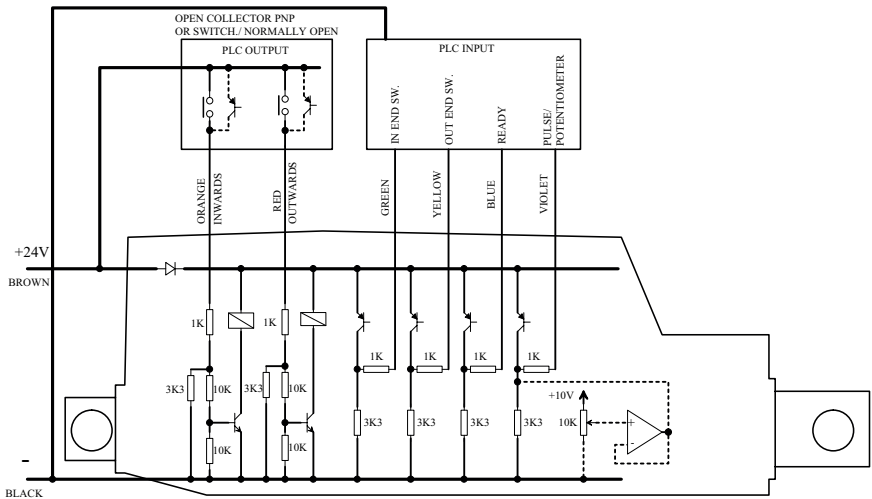
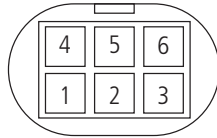

Figure 6

13) Pin-connection for Mini-fit plug (valid for 13 and 14)

| Mini-Fit Connector | |
|--------------------|--|
| Pin 1 | |
| Pin 2 | |
| Pin 3 | |
| Pin 4 | |
| Pin 5 | |
| Pin 6 | |



Connector front view

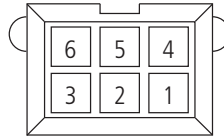

PCBA Header top view



0273011 with O-ring

WITHOUT FEEDBACK

LA27 Mini-fit plug cable (LA27 standard; Valid for LA27 article numbers = 27xxxxxxxxxxx0)

| CH1-4 MiniFit: | |
|---|---|
| When a channel is operated UP (Motor connections) | 3: Brown: + 6: Yellow: - |
| End-of-stroke switches | 5: Orange: UP 4: Red: DOWN 2: Black: COMMON |
| Not Used | 1: No Connection |

(end of stroke = EOS)

LA23/LA31/LA34/BL1/BL4 Mini-fit plug cable

without Feedback

| EOS Switch | |
|------------|-------------------|
| Pin 1 | Switch com. (GND) |
| Pin 2 | Vbus |
| Pin 3 | M+ (Motor/Power) |
| Pin 4 | EOS wout |
| Pin 5 | EOD in |
| Pin 6 | M- (Motor/Power) |

LA27 Mini-fit plug cable (Analog encoded without Hall)

without Feedback

Article numbers = 27xxxxxxxxxxxB

| EOS Switch | |
|-------------------|--|
| Switch com. (GND) | |
| Vbus | |
| M+ (Motor/Power) | |
| EOS out | |
| EOD in | |
| M- (Motor/Power) | |

WITH FEEDBACK

LA23/LA31/LA34/LA44/BL1 Mini-fit plug cable

with Feedback

| Hall | |
|-------|------------------|
| Pin 1 | Hall GND |
| Pin 2 | Vbus |
| Pin 3 | M+ (Motor/Power) |
| Pin 4 | Hall A |
| Pin 5 | Hall B |
| Pin 6 | M- (Motor/Power) |

LA27 Mini-fit plug cable

with Feedback

Article numbers = 27xxxxxxxxxxxA

| Hall | |
|------------------|--|
| Hall com. (GND) | |
| Vbus | |
| M+ (Motor/Power) | |
| EOS (analog) | |
| Hall | |
| M- (Motor/Power) | |

LA34/LA44 Mini-fit plug cable (potentiometer)

Potentiometer

| | |
|-------|------------------|
| Pin 1 | Pot GND |
| Pin 2 | Vbus |
| Pin 3 | M+ (Motor/Power) |
| Pin 4 | Pot Position |
| Pin 5 | Pot + (3V3) |
| Pin 6 | M- (Motor/Power) |

BL4 Mini-fit plug cable

Reed

| |
|------------------|
| Reed com. (GND) |
| Vbus |
| M+ (Motor/Power) |
| NC |
| Reed |
| M- (Motor/Power) |

Figure 7

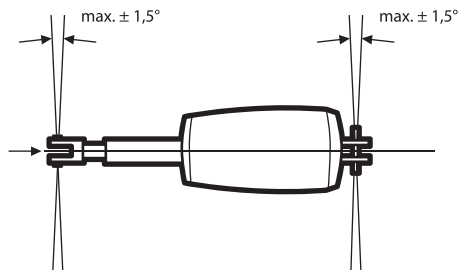

Figure 8

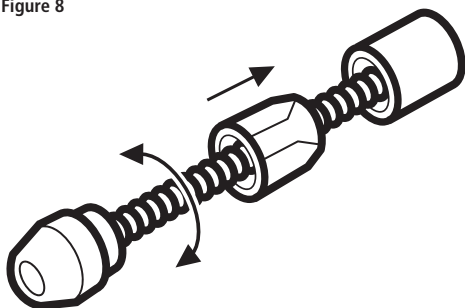

Figure 9

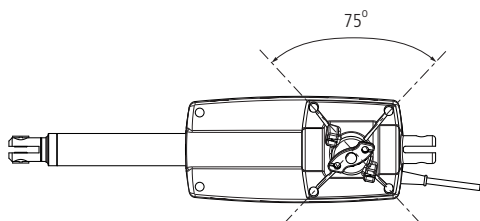
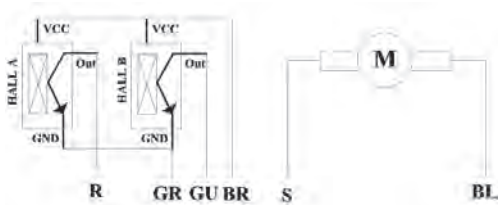

Figure 10



Connecting the system

Do not connect the mains cable until all actuators and hand controls have been connected to the control box.

Start by connecting the hand control to the control box. The connection in the control box is marked with "HB".

Connect the different actuators to the different channels on the control box. Each channel is marked with a number (e.g. "1", "2", "3".....).

Check that all plugs are well connected and firmly pushed into the connector. Due to the fact that LINAK® control boxes are designed for a high IP degree, a firm force can be required.

Connect the mains cable.

The actuators can now be operated by pressing a button on the hand control button.

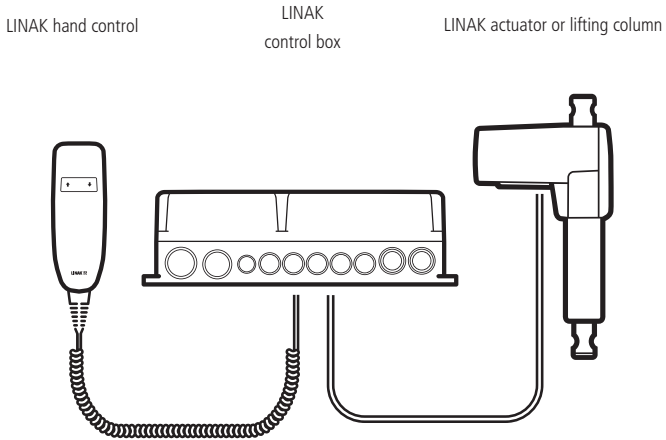

Any non-detachable power supply cord with mains plug is considered to be the disconnecting device.

Charging is only allowed in dry environment, and the appliance inlet must be thoroughly dried before connecting to mains.

- a) Actuators with plugs may only be connected to LINAK control boxes
- b) Actuators without plugs are connected as shown in **Figures 6.1 - 6.12.**

Batteries

Lithium ion batteries



Warnings

- When using Li-Ion batteries with patient lift control boxes, loss of power might happen due to the battery deep discharge protection. This will only happen in case of continuous battery use despite warnings. In this event, there may be no warning, and the application may not be able to move when expected.
- In his risk analysis, the customer must take into consideration how to assure alternative means to make movement, for instance quick release or manual lowering.
- Do not open the battery housing as damaging the cell or circuitry may develop excessive heat.
- If product caution is not clearly visible at low light intensity, read the product label instructions symbol. A warning must be included in the application manufacturer manual for the medical device.
- The application manufacturer must test the application and ensure that intentional and unintended operations do not exceed the battery specification limits.
- Defective or damaged Li-Ion batteries are not allowed for transportation.
- For safety reasons, please adhere to the indicated charging and operation temperature.
- In case the battery is too hot, disconnect it, evacuate the room, and wait for 2 hours before taking further steps.
- Mounting instructions must be followed in order to avoid exposing batteries to water.
- In general, recharging of battery must take place every 6 months. However, please note:
 - New Li-Ion batteries, shipped from LINAK are in a deep-sleep state, where the self-discharge is very little.
 - When mounted in an application, LINAK Li-Ion batteries wake up, resulting in a higher rate of discharge, depending on the application/system. Application manufacturer must consider this idle consumption for his specific system and make precautions to avoid discharged batteries.
 - Contact your LINAK sales team for further information.
- If batteries are to be shipped by air, they shall not be charged to more than 30%.
- Disposal of the battery takes place in accordance with local regulations.



Recommendations:

- Do not exceed the storage temperature as it will shorten the product life and performance.
- Allow the battery to settle to room temperature before use.
- Lithium ion batteries are not intended for use in outdoor applications and indoor pool environments.
- If the battery is completely discharged, then recharge the battery before storage.
- Always use correct LINAK® charger.



DO NOT:

- Heat or burn the batteries.
- Short circuit the batteries.
- Expose the batteries to high impact/excessive force.
- Crush or puncture the batteries.
- Use batteries with signs of damage or corrosion.
- Charge or store the batteries near combustible material.
- Exceed IP-ratings.
- Overcharge or fully discharge the batteries.

For detailed information on specific use of batteries, please see the product information in chapter 5.

Safety feature

Lithium ion batteries contain several mechanisms to protect themselves from being damaged due to excessive use. In case of overheating, the device will activate a thermal protection. No power output will be available until the temperature is again within normal operating range. Overheating may occur by extensive use at high temperatures or when exceeding the duty cycle. (see product label)

Lead acid batteries

Maintenance of batteries

Prior to first use of LINAK® batteries, please make sure that they are charged at least 24 hours and if possible even longer for proper functioning and prolonging the battery lifetime.



Warnings

- Please observe the following maintenance, replacement, and disposal requirements to ensure a safe and reliable operation.
- The batteries are to be replaced after 4 years at the latest. Perhaps earlier, depending on the pattern of use. Frequent and high-powered discharges reduce the battery life. For an optimum lifetime, the product must be connected to the mains voltage as often as possible. It is recommended that the batteries are to be charged for at least every 6 months - otherwise the batteries will have reduced capacity due to self-discharge. It is recommended to test the battery function at least once every year.

Replacement of batteries

The batteries must only be replaced by the same type of batteries or mechanical and electrical equivalent types. The batteries must be new or maintained by means of charging at least every 6 months. The batteries, which make a set, must be supplied with identical production codes.

Production code mismatch may lead to a severely reduced lifetime expectancy.

Before mounting, ensure that the battery set is correctly connected, compare with the drawing in the battery room and check that no connectors are loose.



Warnings

- The battery compartment is hermetically separated from the electronics compartment. When replacing the batteries this separation must not be damaged or modified as this may allow penetration of battery gas into the electronics compartment with risk of explosion.
- When replacing batteries in waterproof products (IPX5 and IPX6), precautions must be taken that the sealing material (silicone ring or joint filler) is not damaged and that it is correctly placed in the groove. Hereafter, the screws in the cover are to be fastened with approx. 1 Nm. If necessary, replacement sealing is available at LINAK.

Disposal

Lead acid batteries must be disposed of in the same way as car batteries. Alternatively, they may be returned to LINAK.



Warnings

- The battery compartment is supplied with ventilation that ensures correct and necessary airing of the battery compartment. This airing must not be blocked or covered as a positive pressure may occur with risk of explosion.
- If the product has been exposed to mechanical overload (lost on the floor, collision/squeezing in the application or a powerful stroke), the product must be sent to an authorised workshop for control of the hermetic separation between the battery and electronics compartment.

2. Information on start-up, deinstallation and operation

Before installation, deinstallation, or troubleshooting:

- Stop the actuator/lifting column.
- Switch off the power supply or pull out the mains plug and pull out the plug to the actuator/lifting column.
- Relieve the actuator/lifting column of any loads, which may be released during the work.

Before start-up:

- Make sure that the system has been installed as instructed in this User Manual.
- The individual parts (actuator/lifting column/hand controls etc.) must be connected before the control box is connected to the mains.
- Make sure that the mains voltage to be connected to the product or the system is the one stated on the label.
- The equipment can be moved freely over the whole working area of the actuator/lifting column.
- Check correct function after mounting.
- The actuator/lifting column must not be loaded in excess of the values indicated in the specifications on the product label.
- The duty cycle noted on the product label must always be observed. Otherwise there is a risk of product damage. Exceeding the duty cycle will result in a dramatic reduction of the system lifetime.
Unless specified otherwise on the product label, the duty cycle is max. 10%, max. 2 minutes in use followed by 18 minutes not in use.
- The actuator/lifting column system may only be used in an environment corresponding to the IP rating of the system. LINAK products are marked with the actual IP rating on the label.
- If any individual parts are suspected to be damaged, do not install the parts, but return them for inspection/service.

During operation:

- Check for unusual sounds and irregular movement. Stop the actuator/lifting column immediately if anything unusual is observed.
- If the control box makes unusual noises or smells, switch off the mains voltage immediately and the external battery, if any.
- Take care that the cables are not damaged.
- Unplug the mains cable on mobile equipment before it is moved.

Troubleshooting Actuators/Lifting columns

| Symptom | Possible cause | Action |
|--|--|---|
| No motor sound or movement of piston rod | - The actuator is not connected to the control box - Blown fuse in the control box - Cable damaged | - Connect the actuator to the control box - Fuse must be changed - Send actuator for repair |
| Excessive electricity consumption | | - Send actuator for repair |
| Motor runs but spindle does not move | - Gear wheel or spindle damaged | - Send actuator for repair |
| Actuator cannot lift full load | - Clutch is worn - Motor is damaged | - Send actuator for repair |
| Motor sound but no movement of piston rod | | - Send actuator for repair |
| No signal from Reed or Hall switch | | - Send actuator for repair |
| Motor runs and quick release does not function or is noisy | - Declutching arm turns less than approx. 75 °C | - Adjust cable |
| Piston rod will only move inwards and not outwards | - Safety nut has operated | - Send actuator for repair |
| Motor runs too slowly or does not give full force | - Insufficient power supply - Voltage drop in cable | - Increase power supply - Thicker cable necessary |

Troubleshooting Electronics

| Symptom | Possible cause | Action |
|--|--|--|
| Power indicator does not light up | - Not connected to mains | - Connect to mains |
| | - The fuse has blown | - Replace fuse, if the system is prepared for external fuse replacement, or send the system for repair |
| | - Defective power cable | - On control boxes with exchangeable power cable, change the cable. - On control boxes with fixed cable, send it for repair |
| | - Control box defective | - Send control box for repair |
| Power indicator lights up, but actuator does not run | - Actuator plug not pushed into control box properly | - Push actuator plug properly into control box |
| Control box relays are clicking | - Actuator defective | - Replace actuator - Defective control box - Replace the control box |
| Power indicator lights up, but actuator does not run | - Control box defective | - Send control box for repair |
| No relay noise is heard from control box Not valid for CB20/CB6S OBF/CB16 OBF | - Hand control defective | - Send hand control for repair |
| Control box completely dead on battery and no relay clicking | - Battery completely flat | - Charge battery |
| | - Battery defective | - Replace battery |
| Actuator does not run on battery, but relay clicking can be heard | - Actuator plug not properly pushed into control box | - Push actuator plug properly into control box |
| | - Actuator defective | - Replace actuator |
| | - Control box defective | - Replace control box |
| Control box okay apart from one direction on one channel | - Hand control defective - Control box defective | - Send hand control for repair - Send control box for repair |

3. Information on specific actuators

1. LA20 Inline (MEDLINE® CARELINE®)

LINAK®

Designed in Denmark
DK - 6430 Nordborg

Type : 200250500A0M0G26+023020000Q227

Item No. : J21264

Prod. Date : 2018.06.18

Max Load : Push 2500 N IPX6

Power Rate: 24 V=, Max. 1.3 A

Duty Cycle : 10%, Max. 2 min. / 18 min.

⚠ NOT TO BE OPENED BY UNAUTHORIZED PERSONNEL
NE PAS OUVRIR PAR DU PERSONNEL NON AUTORISÉ

W/O#-0001



LA20 is a slim inline actuator created to cover a wide range of applications, where design, size and power are crucial. The combination of a high lifting capacity of 2,500 N with its robust but stylish, small form factor makes the LA20 the ideal solution for many of today's demanding applications.

Usage

- Duty cycle: Max. 10 %, 2 minutes continuous use followed by 18 minutes not in use
- Usage temperature: +5 °C to +45 °C normal operating temp.
-27 °C to +50 °C (according to test conditions ISO 7176-9)
- Storage temperature: -40 °C to +70 °C (according to ISO 7176-9)
- Compatibility: Compatible with LINAK control boxes. Please contact LINAK
- Relative humidity: 20% to 80% - non-condensing
- Approvals: IEC60601-1, ANSI/AAMI ES60601-1,
CAN/CSA-C22.2 No. 60601-1
In compliance with ISO 7176-8
- Atmospheric pressure: 700 to 1060 hPa
- Meters above sea level: Max. 3000 meters
- Cycles: The LA20 life cycle test has been performed with a stabilised power supply (10% duty cycle) on a 120 mm stroke actuator at max. load for 10,000 cycles (at ambient temperature)
- Flammability rating: UL94-V0



Warnings

- Do not sideload the actuator
- Only use the actuator within specified working limits
- When mounting the LA20 in the application ensure that the bolts can withstand the wear and they are secured safely
- Motor type G and B must only be used with their respective control box types.
- Motor type B: motor which must be used with COBO, CBJC, CBJ1, CBJ2, CBJH or generally in applications that are mainly battery driven or customers' own control box.
- Motor type G: motor which must be used with CO61, CO71, CO41, CA30/40.
- Instruction concerning the turning of the piston rod eye: When mounting and taking into use, it is not permitted to make excessive turns of the piston rod eye. In cases where the eye is not positioned correctly, it is permitted to first screw the eye down to its bottom position, at a maximum torque of 2 Nm (1), and thereafter a maximum half turn outwards again (2).
- If an actuator with stroke length below 50 mm is used, and the electrical endstop switch fails, be aware that the distance before reaching the mechanical endstop will be prolonged.
The extra distance will be 50 mm minus the actual stroke length.
This means that an actuator with 20 mm stroke length will travel an additional 30 mm before reaching the mechanical endstop if the switch fails.



Recommendations

- Do not place load on the actuator housing and do prevent impact or blows or any other form of stress to the housing
- Connection bolts must be dimensioned so that they have the necessary strength and tolerance in order to obtain the minimum safety factor according to the requirements of the authorities
- Ensure that the cable lock is mounted correctly
- Ensure that the cable cannot be squeezed, pulled or subjected to any other stress
- Only use the actuator within the specifications
- Connection bolts and brackets are to be inspected in connection with service and must be replaced if there are signs of wear
- The product must always have the motor short circuited to obtain self-locking according to label value/rated value
- Ensure that the duty cycles and the usage temperatures for LA20 actuators are respected
- The LA20 is not suitable for use in outdoor applications where it can be exposed to sun and rain.
- Do not expose the actuator to pull during transport of the application

Cable mounting

A: To mount a cable



Step 1:
Place the cable in the actuator



Step 2:
Press the cable lock down into place

B: To remove/change a cable



Step 1:
Place a screwdriver in the hole in the back figure of the actuator

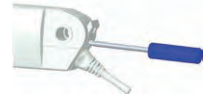

Step 2:
Push to remove the cable lock
and remove/change the cable

Feedback specifications

| E1 (Power switch) F1 (Motortype A + B) | |
|--|------------------|
| 1 | Not connected |
| 2 | Not connected |
| 3 | M+ (Motor/power) |
| 4 | Not connected |
| 5 | Not connected |
| 6 | M- (Motor/power) |

| E1 (Power switch) F2 (Dual Hall Digital) See later page (Motortype A + B) | | Encoded | *EOS |
|---|---------------------|-------------|------|
| 1 | External supply: 0V | 2.65V-3.25V | NONE |
| 2 | VCC | 2.15V-2.65V | NONE |
| 3 | M+ (Motor/power) | 1.65V-2.15V | OUT |
| 4 | Hall A | 1.15V-1.65V | OUT |
| 5 | Hall B | 0.65V-1.15V | IN |
| 6 | M- (Motor/power) | 0.05V-0.65V | IN |

| E1 (Power switch) F7 (Hall Potentiometer) See later page (Motortype A + B) | | Interval | Hall-A | *EOS |
|--|------------------------|-------------|--------|------|
| 1 | External supply: 0V | 2.65V-3.25V | LOW | NONE |
| 2 | VCC | 2.15V-2.65V | HIGH | NONE |
| 3 | M+ (Motor/power) | 1.65V-2.15V | LOW | OUT |
| 4 | Analog feedback output | 1.15V-1.65V | HIGH | OUT |
| 5 | Not connected | 0.65V-1.15V | LOW | IN |
| 6 | M- (Motor/power) | 0.05V-0.65V | HIGH | IN |

| E2 (Signal) F1 (Motortype G) | |
|------------------------------|------------------|
| 1 | Not connected |
| 2 | VCC |
| 3 | M+ (Motor/power) |
| 4 | EOS IN |
| 5 | EOS OUT |
| 6 | M- (Motor/power) |

| E3 (Encoded) F3 (Motortype G) | |
|-------------------------------|---------------------------------------|
| 1 | External supply: 0V |
| 2 | VCC |
| 3 | M+ (Motor/power) |
| 4 | Analogue encoded (Hall-A+EOS* IN/OUT) |
| 5 | Not connected |
| 6 | M- (Motor/power) |

| E3 (Encoded) F3 (Dual Hall encoded) (Motortype G) | |
|---|---|
| 1 | External supply: 0V |
| 2 | VCC |
| 3 | M+ (Motor/power) |
| 4 | Hall A/Analogue encoded (Hall-A+EOS* IN/OUT) |
| 5 | Hall B with Dual-Hall or N/C when testing without Dual Hall |
| 6 | M- (Motor/power) |

Input/output specifications: dual hall positioning

Dual Hall, Encoded (F3) is used only for LINAK A/S control boxes.

Dual Hall, Digital (F2) is used for customers' own control boxes.

Dual Hall, Digital (F2) Positioning:

| Item | Specification | Comment | | | | | | | | | | | | |
|-------------------|---|---|-----|-------|-----|-------|----|-------|--------|-------|--------|-------|----|--|
| Pin configuration | <table border="1"> <tr> <td>Pin 1</td> <td>GND</td> </tr> <tr> <td>Pin 2</td> <td>VCC</td> </tr> <tr> <td>Pin 3</td> <td>M+</td> </tr> <tr> <td>Pin 4</td> <td>HALL A</td> </tr> <tr> <td>Pin 5</td> <td>HALL B</td> </tr> <tr> <td>Pin 6</td> <td>M-</td> </tr> </table> | Pin 1 | GND | Pin 2 | VCC | Pin 3 | M+ | Pin 4 | HALL A | Pin 5 | HALL B | Pin 6 | M- | |
| Pin 1 | GND | | | | | | | | | | | | | |
| Pin 2 | VCC | | | | | | | | | | | | | |
| Pin 3 | M+ | | | | | | | | | | | | | |
| Pin 4 | HALL A | | | | | | | | | | | | | |
| Pin 5 | HALL B | | | | | | | | | | | | | |
| Pin 6 | M- | | | | | | | | | | | | | |
| VCC | 4-15V | Feedback circuit has to be powered 50 ms before driving, and until actuator has stopped moving | | | | | | | | | | | | |
| Current | Maximum 15mA @10kΩ and 1nF load. See diagram. | | | | | | | | | | | | | |
| HALL A/B | <p>TState is minimum 5ms in all states (11,10,00,01)</p> <p>Duty cycle Hall A 30-70%</p> <p>Duty cycle Hall B 30-70%</p> <p>Low level <GND+0.5V @10kΩ and 1nF load</p> <p>High level >VCC-0.5V @10kΩ and 1nF load</p> <p>Driving out, the Hall B signal will go high when Hall A signal is low.</p> <p>Driving in, the Hall A signal will go high when Hall B signal is low.w</p> | <p>Driving outwards</p> <p>Driving inwards</p> | | | | | | | | | | | | |
| Resolution | <p>The feedback system gives 16 state shifts per spindle turn.</p> <p>3 mm pitch => 0.1875 mm per shift</p> <p>4 mm pitch => 0.25 mm per shift</p> | <p>On 100 mm stroke you will have the following number of pulses:</p> <p>3 mm pitch => 533 shifts</p> <p>4 mm pitch => 400 shifts</p> | | | | | | | | | | | | |

Input/output specifications: dual Hall encoded

| Item | Specification | Comment | | | | | | | | | | | | | | | | | | | | | | | | | | | | | | | | | |
|-------------------|---|--|----------------------|-------|-----|-------|------------------|-------|--|-------|---|-------|------------------|--|----------|--------|------|-------------|-----|------|-------------|------|------|-------------|-----|-----|-------------|------|-----|-------------|-----|----|-------------|------|----|
| Description | The actuator can be equipped with two hall sensors A and B and a spindle magnet. In this way you can have pulses from the actuator when it moves. | Only use for standard actuators, with LINAK A/S Control Boxes for OpenBus™. | | | | | | | | | | | | | | | | | | | | | | | | | | | | | | | | | |
| Pin configuration | <table border="1"> <tr> <td data-bbox="274 225 364 264">Pin 1</td> <td data-bbox="364 225 610 264">External supply: 0 V</td> </tr> <tr> <td data-bbox="274 264 364 296">Pin 2</td> <td data-bbox="364 264 610 296">VCC</td> </tr> <tr> <td data-bbox="274 296 364 328">Pin 3</td> <td data-bbox="364 296 610 328">M+ (motor/power)</td> </tr> <tr> <td data-bbox="274 328 364 384">Pin 4</td> <td data-bbox="364 328 610 384">HALL A, analogue encoded (Hann-A +EOS* IN/OUT)</td> </tr> <tr> <td data-bbox="274 384 364 440">Pin 5</td> <td data-bbox="364 384 610 440">HALL B with dual Hall or N/C when testing without dual Hall</td> </tr> <tr> <td data-bbox="274 440 364 472">Pin 6</td> <td data-bbox="364 440 610 472">M- (motor/power)</td> </tr> </table> | Pin 1 | External supply: 0 V | Pin 2 | VCC | Pin 3 | M+ (motor/power) | Pin 4 | HALL A, analogue encoded (Hann-A +EOS* IN/OUT) | Pin 5 | HALL B with dual Hall or N/C when testing without dual Hall | Pin 6 | M- (motor/power) | <table border="1"> <thead> <tr> <th data-bbox="610 225 744 264">Interval</th> <th data-bbox="744 225 868 264">Hall-A</th> <th data-bbox="868 225 1064 264">*EOS</th> </tr> </thead> <tbody> <tr> <td data-bbox="610 264 744 296">2.65V-3.25V</td> <td data-bbox="744 264 868 296">LOW</td> <td data-bbox="868 264 1064 296">NONE</td> </tr> <tr> <td data-bbox="610 296 744 328">2.15V-2.65V</td> <td data-bbox="744 296 868 328">HIGH</td> <td data-bbox="868 296 1064 328">NONE</td> </tr> <tr> <td data-bbox="610 328 744 360">1.65V-2.15V</td> <td data-bbox="744 328 868 360">LOW</td> <td data-bbox="868 328 1064 360">OUT</td> </tr> <tr> <td data-bbox="610 360 744 392">1.15V-1.65V</td> <td data-bbox="744 360 868 392">HIGH</td> <td data-bbox="868 360 1064 392">OUT</td> </tr> <tr> <td data-bbox="610 392 744 424">0.65V-1.15V</td> <td data-bbox="744 392 868 424">LOW</td> <td data-bbox="868 392 1064 424">IN</td> </tr> <tr> <td data-bbox="610 424 744 472">0.05V-0.65V</td> <td data-bbox="744 424 868 472">HIGH</td> <td data-bbox="868 424 1064 472">IN</td> </tr> </tbody> </table> | Interval | Hall-A | *EOS | 2.65V-3.25V | LOW | NONE | 2.15V-2.65V | HIGH | NONE | 1.65V-2.15V | LOW | OUT | 1.15V-1.65V | HIGH | OUT | 0.65V-1.15V | LOW | IN | 0.05V-0.65V | HIGH | IN |
| Pin 1 | External supply: 0 V | | | | | | | | | | | | | | | | | | | | | | | | | | | | | | | | | | |
| Pin 2 | VCC | | | | | | | | | | | | | | | | | | | | | | | | | | | | | | | | | | |
| Pin 3 | M+ (motor/power) | | | | | | | | | | | | | | | | | | | | | | | | | | | | | | | | | | |
| Pin 4 | HALL A, analogue encoded (Hann-A +EOS* IN/OUT) | | | | | | | | | | | | | | | | | | | | | | | | | | | | | | | | | | |
| Pin 5 | HALL B with dual Hall or N/C when testing without dual Hall | | | | | | | | | | | | | | | | | | | | | | | | | | | | | | | | | | |
| Pin 6 | M- (motor/power) | | | | | | | | | | | | | | | | | | | | | | | | | | | | | | | | | | |
| Interval | Hall-A | *EOS | | | | | | | | | | | | | | | | | | | | | | | | | | | | | | | | | |
| 2.65V-3.25V | LOW | NONE | | | | | | | | | | | | | | | | | | | | | | | | | | | | | | | | | |
| 2.15V-2.65V | HIGH | NONE | | | | | | | | | | | | | | | | | | | | | | | | | | | | | | | | | |
| 1.65V-2.15V | LOW | OUT | | | | | | | | | | | | | | | | | | | | | | | | | | | | | | | | | |
| 1.15V-1.65V | HIGH | OUT | | | | | | | | | | | | | | | | | | | | | | | | | | | | | | | | | |
| 0.65V-1.15V | LOW | IN | | | | | | | | | | | | | | | | | | | | | | | | | | | | | | | | | |
| 0.05V-0.65V | HIGH | IN | | | | | | | | | | | | | | | | | | | | | | | | | | | | | | | | | |
| Resolution | <p>The feedback system has an 8P magnet which gives 16 shifts in pulses per spindle turn:</p> <p>2.5 mm pitch = 0.1563 mm per pulse 3.0 mm pitch = 0.1875 mm per pulse 4.0 mm pitch = 0.25 mm per pulse 5.0 mm pitch = 0.3125 mm per pulse 6.0 mm pitch = 0.375 mm per pulse</p> | <p>Pulse/pause minimum 10 milli-seconds. On 100 mm stroke you will have the following number of pulses:</p> <p>2.5 mm pitch = 640 pulses 3.0 mm pitch = 533 pulses 4.0 mm pitch = 400 pulses 5.0 mm pitch = 320 pulses 6.0 mm pitch = 267 pulses</p> | | | | | | | | | | | | | | | | | | | | | | | | | | | | | | | | | |
| Connection | 6 pins micro-fit | Use cables: Standard 6 wires | | | | | | | | | | | | | | | | | | | | | | | | | | | | | | | | | |
| Combination | Only standard | | | | | | | | | | | | | | | | | | | | | | | | | | | | | | | | | | |

Input/output specifications: Hall potentiometer feedback

The Hall potentiometer feedback is an option on the LA20. This is especially suitable for wheelchairs or other applications as the LINAK control boxes are not suitable of handling the signal.

- Hall potentiometer is close to be an absolute positioning system
- Hall potentiometer is a long lasting and wear-resistant positioning system
- Enables compact products to have precise positioning (potentiometer increase the product potential)

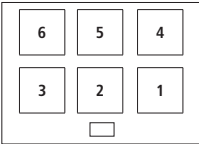
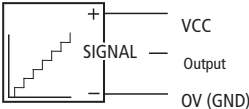
| Item | Specification | Comment | |
|---------------------|---|--|--|
| Pin configuration | Pin 1 | External supply: V0 | Actuator connector front view:  |
| | Pin 2 | VCC | |
| | Pin 3 | M+ (motor/power) | |
| | Pin 4 | Hall potentiometer | |
| | Pin 5 | Not connected | |
| | Pin 6 | M- (motor/power) | |
| Description | The actuator can be equipped with an electronic circuit that gives a feedback signal when the actuator moves. |  | |
| Input voltage | VCC = 5V – 12 V DC | Feedback circuit has to be powered 1 second before and after the motor runs and until the actuator has stopped. Cable dimension 0.32 mm ³ (AWG22) | |
| Output voltage | 0.3V – 3.0V @ Load > 100kΩ 0.3V = EOS IN 3.0V = EOS OUT | | |
| Current consumption | Current consumption is max 20 mA @ 12V | Also when actuator is not running | |
| Combinations | The absolute positioning can be combined with potential free switches, but cannot be combined with relative positioning | | |

Motor specification

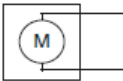
| Item | Specification | Comment | |
|---------------------|--|---|---|
| Pin connection | Pin 1 | | Outwards: Pin 3: + Pin 6: - Inwards: Pin 3: - Pin 6: + |
| | Pin 2 | | |
| | Pin 3 | M+/- | |
| | Pin 4 | | |
| | Pin 5 | | |
| | Pin 6 | M-/+ | |
| Description | Permanent magnet DC motor, available in 12V motor type A, 24V motor type B or 24V motor type G. |  <p>EMC noise from the motor is dealt with in LINAK A/S control boxes. If using the actuator in another application, it is up to the customer to be EMC compliant.</p> | |
| Input voltage | Motor type A +/- 10% Motor Type B +/- 10% Motor Type G +/- 10% | | |
| Current consumption | Motor type A, 0-1 - 1.3A depending on load Motor Type B, 0-1 - 1.3A depending on load Motor Type G, 0.1 - 1.0A depending on load | See curves for typical values | |
| Speed regulations | The motor can run with PWM regulation. This could be used for soft start/stop etc. | | |

2. LA23 (DESKLINE®)



The LA23 is a small and strong push actuator (up to 2500 N). The LA23 can be used in various applications where size is important. The LA23 is e.g. ideal for adding tilt-function to a desk, so the table top can tilt or for adjustment in handicap kitchens.

Some of the benefits the LA23 offers you are:

- Compact design
- High lifting force
- Exchangeable cables

Usage:

- Duty cycle: 10 %, 2 minutes continuous use followed by 18 minutes not in use
- Usage temperature: +5 °C - +40 °C normal operating temp.
-30 °C - +50 °C according to test conditions: ISO 7176-9
- Storage temperature: -45 °C to +70 °C (according to ISO 7176-9)
- Compatibility: DESKLINE Control boxes.
SLS must be ignored Up + Down in the CBD4, when configured for LA23 and in the CBD6S with old actuators.
- Approved according to EN60335-1 with CBD6S
- Flammability rate: Enclosure UL94-V0
- Cycles: The LA23 Life cycle test has been performed with a stabilised power supply (10 % duty cycle) on a 200 mm stroke actuator at max. load at 5000 cycles



Warnings

- Do not sideload the actuator.
- Only use the actuator within specified working limits.
- When mounting the LA23 in the application ensure that the bolts can withstand the wear and that they are secured safely.
- If an actuator with stroke length below 50 mm is used, and the electrical end-stop switch fails, please be aware that the distance before reaching the mechanical end-stop will be prolonged. The extra distance will be 50 mm minus actual stroke length.
I.e. If an actuator with 20 mm stroke length is used and the switch fails, it will travel an additional 30 mm before reaching the mechanical end-stop.
- Instruction concerning the turning of the piston rod eye
When mounting and taking into use, it is not permitted to make excessive turns of the piston rod eye. In cases where the eye is not positioned correctly, it is permitted to first screw the eye down to its bottom position, at a maximum torque of 2 Nm (1), and thereafter a maximum half turn outwards again (2).



Recommendations:

- Do not place load on the actuator housing and do prevent impact or blows, or any other form of stress to the housing.
- Ensure that the cable lock is mounted correctly.
- Ensure that the duty cycle and the usage temperatures for LA23 actuators is respected.
- Ensure that the cable cannot be squeezed, pulled or subjected to any other stress.
- The LA23 is not suitable for use in outdoor applications where it can be exposed to sun and rain.

If outdoor use cannot be avoided, it is very important that the LA23 is mounted in a position where it is well shielded. It is up to the customer to provide the shielding. Furthermore, it will be good practice to ensure that the actuator is fully retracted in the "normal" position. The reason is that there will be a vacuum inside the actuator if it is extended which over time can lead to water entering the actuator.

The item numbers for ordering the Cable Lock are:

- Item number: 0231007 (light grey) for one cable lock (1 piece).
- Item number: 0231037 (black) for one cable lock (1 piece).

Below you see an instruction in how to mount and remove the cable lock from LA23.

a) Mount a cable lock:

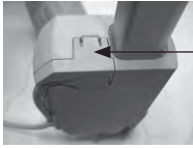

Push down until the cable lock clicks into place.

b) Cable lock removal



Step 1:
Insert e.g. a screwdriver at a 45 °C angle as illustrated.



Step 2:
Turn the screwdriver to release the cable lock.



Step 3:
Now the cable lock can be removed by hand.

Note: When a cable lock has been removed, it is recommended to replace it with a new.

3. LA23 (MEDLINE® CARELINE® TECHLINE®)

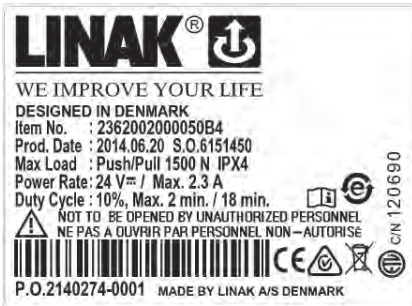

The LA23 is a small and strong push/pull actuator (up to 2,500 N). The LA23 can be used in various applications where size is important.

Some of the benefits the LA23 offers you are:

- Compact design
- High lifting force
- Exchangeable cables

Usage:

- Duty cycle: 10 %, 2 minutes continuous use followed by 18 minutes not in use
- Usage temperature: +5 °C - +40 °C normal operating temp.
-30 °C - +50 °C according to test conditions: ISO 7176-9
- Storage temperature: -45 °C to +70 °C (according to ISO 7176-9)
- Compatibility: Compatible with LINAK control boxes. Please contact LINAK
- Approvals: IEC60601-1, ANSI/AAMI ES60601-1, CAN/CSA 22.2 No 60601-01
LA23IC is not approved according to the above.
LA23 in combination with CBD4, CBD5 & CBD6 has no approvals.
- Flammability rating: Enclosure UL94-V0

Warnings

- All IC (Integrated Controls) versions are not compliant for Medical use.
- Do not sideload the actuator.
- Only use the actuator within specified working limits.
- Always use steel backfixture for LA23 over 1500N and for pull loads.
- When mounting the LA23 in the application ensure that the bolts can withstand the wear and that they are secured safely.
- The B and G 24V motors must only be used with their respective control box types.
 - Motor type A: 12V
 - Motor type B: 24V motor which must be used with JUMBO; CBJ1/2, CBJC and CBJH or generally in applications which are mainly driven with battery
 - Motor type G: 24V motor which must be used with OpenBus™ control boxes; CB20, CB16, CB6S, CA30, CA40, CO61
- If an actuator with stroke length below 50 mm is used, and the electrical end-stop switch fails, please be aware that the distance before reaching the mechanical end-stop will be prolonged. The extra distance will be 50 mm minus actual stroke length. I.e. If an actuator with 20 mm stroke length is used and the switch fails, it will travel an additional 30 mm before reaching the mechanical end-stop. Please make sure that the application can withstand this in a safe way.
- Instruction concerning the turning of the piston rod eye. When mounting and taking into use, it is not permitted to make excessive turns of the piston rod eye. In cases where the eye is not positioned correctly, it is permitted to first screw the eye down to its bottom position, at a maximum torque of 2 Nm (1), and thereafter a maximum half turn outwards again (2).



Recommendations

- Do not place load on the actuator housing and do prevent impact or blows, or any other form of stress to the housing.
- Ensure that the cable lock is mounted correct.
- Ensure that the duty cycle and the usage temperatures for LA23 actuators is respected
- Ensure that the cable cannot be squeezed, pulled or subjected to any other stress.
- The LA23 is not suitable for use in outdoor applications where it can be exposed to sun and rain.
If outdoor use cannot be avoided, it is very important that the LA23 is mounted in a position where it is well shielded. It is up to the customer to provide the shielding. Furthermore, it will be good practice to ensure that the actuator is fully retracted in the "normal" position. The reason is that there will be a vacuum inside the actuator if it is extended which over time can lead to water entering the actuator.
- The B and G 24V motors must only be used with their respective control box types.
- Not acceptable: B motor with OpenBus™ control boxes!
Reason: The actuator will be too strong, it will run too fast, be noisy and only have a short lifetime. The actuator will not live up to what we promise.
- Not acceptable: G motor with 24V supply!
Reason: The actuator will be too weak, this means it will only run slowly, not be able to lift as much in the cold and under low current conditions. The actuator will not live up to what we promise.

The item numbers for ordering the Cable Lock are:

- Item number: 0231007 (light grey) for one cable lock (1 piece).
- Item number: 0231037 (black) for one cable lock (1 piece).

Below you see an instruction in how to mount and remove the cable lock from LA23.

a) Mount a cable lock:



Push down until the cable lock clicks into place.

b) Cable lock removal



Step 1:
Insert e.g. a screwdriver at a 45 °C angle as illustrated.



Step 2:
Turn the screwdriver to release the cable lock.



Step 3:
Now the cable lock can be removed by hand.

Note: When a cable lock has been removed, it is recommended to replace it with a new.

Connection diagrams:

Standard electrical end stop - no positioning

23XXXXXX00XXXXX

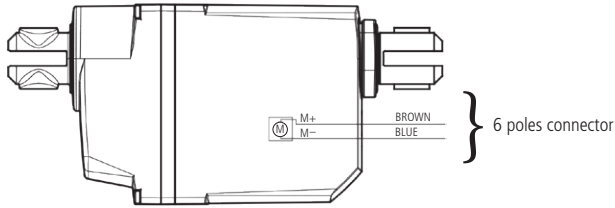

Standard electrical end stop and potential free end stop - no positioning

23XXXXXX01XXXXX

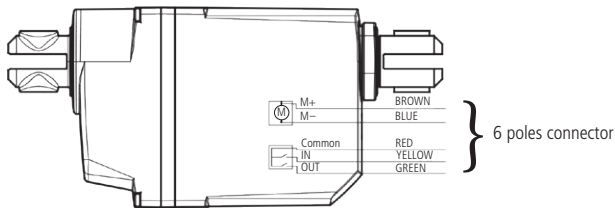

Dual Hall digital positioning

23XXXXXX02XXXXX

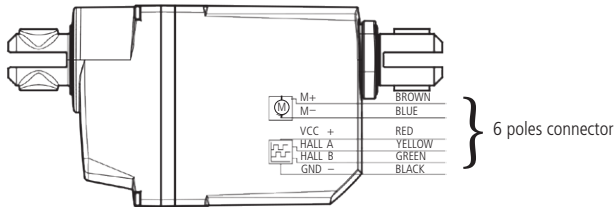

Dual Hall PNP positioning

23XXXXXX03XXXXX



Note: Connection colours only fit with "open-end cables.



Note: If reversed driving is wanted this has to be done by using different cables.

Hall Potentiometer feedback and potential free end stop
 23XXXXXX2XXXXXX

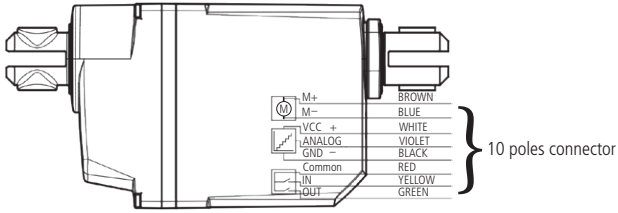

Hall Potentiometer feedback
 23XXXXXX1XXXXXX

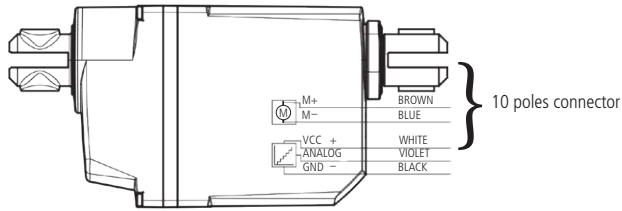

Hall PWM position feedback and potential free end stop
 23XXXXXX4XXXXXX

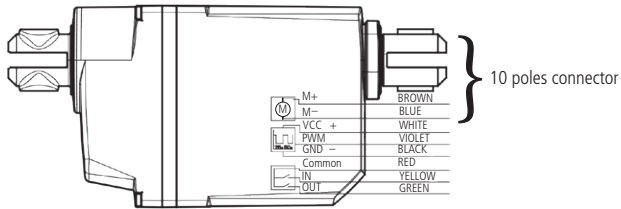

Note: Connection colours only fit with "open-end" cables.

Hall PWM position feedback
 23XXXXXX3XXXXXX

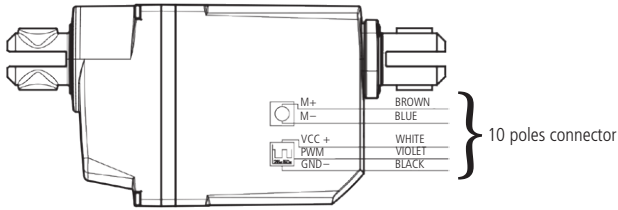

Standard Integrated Control
 23XXXXXX5XXXXXX

Integrated Control with Hall Potentiometer position feedback
 23XXXXXX6XXXXXX

Integrated Control with Hall PWM position feedback
 23XXXXXX7XXXXXX

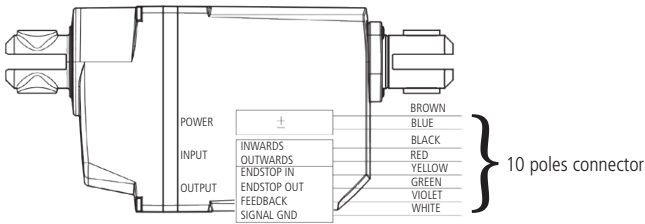

Drawing no.: 0239010-A



LA23 with integrated control is not approved according to IEC60601-1, ANSI/AAMI ES60601-1.



Note: Connection colours only fit with "open-end" cables.

Input/Output specifications: Motor

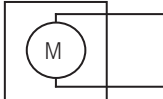
| Item | Specification | Comment |
|---------------------|---|--|
| Description | Permanent magnet DC motor, available in 12 V or 24 V |  <p>EMC noise from the motor is dealt with in LINAK A/S Control boxes. If using the actuator in another application it is up to the customer to be EMC compliant.</p> |
| Input voltage | 12 V DC, +/- 20 % 24 V DC, +/- 10 % | Cable dimension 0.50 mm ² (AWG20) |
| Current consumption | 12 V, 0.2 - 6 A depending on load 24 V, 0.1 - 3 A depending on load | See curves for typical values |
| Speed regulations | The motor can run with PWM regulation. This could be used for soft start/stop etc. | |
| Connection | To extend actuator: Connect Brown to positive, Connect Blue to negative To retract actuator: Connect Brown to negative, Connect Blue to positive | Cables: Standard 6 wires: 0237002-xxxx Absolute positioning 8 wires: 0237001-xxxx |

Input/Output specifications: Potential free end stop signals (01, 2x and 4x in ordering example)

Potential free end stop signals provide a signal when the actuator has reached end stop. This signal can be utilized to provide confirmation that end stop is reached. (Not for LINAK control boxes)

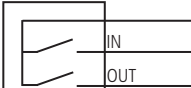
| Item | Specification | Comment |
|--------------------|--|---|
| Description | The actuator can be equipped with two separate detector switches that are activated when the actuator is fully retracted (IN) or when fully extended (OUT). The detector switches are normally open. |  |
| Input Voltage | 3 - 20 V DC | Cable dimension 0.22 mm ² (AWG24) |
| Output Voltage | Same as input voltage | |
| Switching capacity | Max.: 50 mA 20 V DC Min.: 100 µA 3 V DC | |
| Connection | Common: Red Actuator retracted: Yellow Actuator extended: Green | Use Cables: Standard 6 wires: 0237002 - xxxx PLC/Absolute positioning 8 wires: 0237001 - xxxx |
| Combinations | The potential free switches can be combined with absolute feedback. But cannot be combined with "PLC/option" | |

Input/ Output specifications: Dual Hall, digital positioning (02 in ordering example)

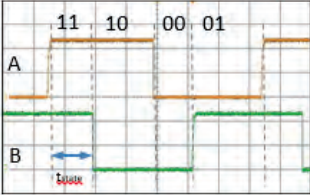
| Item | Specification | Comment |
|--|--|--|
| Description | The actuator can be equipped with two hall sensors A and B and a spindle magnet. In this way you can have pulses from the actuator when it moves. | Only use for standard actuators, with LINAK A/S Control Boxes for OpenBus™. |
| Resolution  | The feedback system has an 8P magnet which gives 16 shifts in pulses per spindle turn: 3 mm pitch = 0.1875 mm per pulse 5 mm pitch = 0.3125 mm per pulse 6 mm pitch = 0.375 mm per pulse 9 mm pitch = 0.5625 mm per pulse 12 mm pitch = 0.75 mm per pulse 20 mm pitch = 1.25 mm per pulse See drawing for details. Tstate is minimum 5ms in all states (11.10.00.01) | Pulse/pause minimum 10 milli-seconds. On 100 mm stroke you will have the following number of pulses: 3 mm pitch = 533 pulses 5 mm pitch = 320 pulses 6 mm pitch = 267 pulses 9 mm pitch = 178 pulses 12 mm pitch = 133 pulses 20 mm pitch = 80 pulses |
| Connection | 6 pins mini-fit | Use cables: Standard 6 wires: 0237003-xxxx |
| Combination | Only standard | |

Input/Output specifications: Dual Hall positioning PNP (03 in ordering example)

The Dual Hall positioning PNP is an option on LA23. This is especially suitable for wheelchairs or TECHLINE applications as the LINAK control boxes have their own option 02 for that purpose.

- Is protected against loaddump and wrong placement of wires

Input/Output specifications: Dual Hall positioning PNP

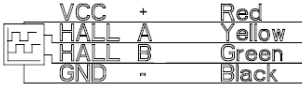
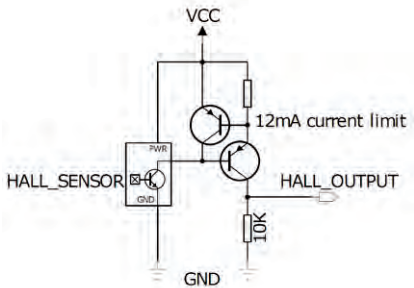
| Item | Specification | Comment |
|----------------|---|--|
| Description | The actuator can be equipped with two hall sensors A and B and a spindle magnet. In this way you can have pulses from the actuator when it moves. |  |
| Input voltage | 9 - 32 V DC | Feedback circuit has to be powered 1 second before driving and until the actuator has stopped. |
| Output voltage | PNP source current: max. 12 mA. HIGH: Output = VCC-1.2 V (± 0.5 V) LOW: Output = 10K Ω pull down tRISE < 100 us @24V LOAD: 5 m cable 1 nF//10 K Ω tFALL < 100 us @24V LOAD: 5 m cable 1 nF//10 K Ω tstate > 10 ms @24V LOAD: 5 m cable 1 nF//10 K Ω |  |
| Current | Max. 20 mA + source current. | Also when actuator is not running. |
| Protection | LOAD DUMP Wire wrong placement | |
| Resolution | The feedback system has an 8P magnet which gives 16 shifts in pulses per spindle turn: 3 mm pitch = 0.1875 mm per pulse 6 mm pitch = 0.375 mm per pulse 9 mm pitch = 0.5625 mm per pulse 12 mm pitch = 0.75 mm per pulse 20 mm pitch = 1.25 mm per pulse See drawing for details. Tstate is minimum 5 ms in all states (11.10.00.01) | On 100 mm stroke you will have the following number of pulses: 3 mm pitch = 533 pulses 6 mm pitch = 267 pulses 9 mm pitch = 178 pulses 12 mm pitch = 133 pulses 20 mm pitch = 80 pulses |
| Cable | Connection M+: Brown M-: Blue VCC: Red HALL A: Yellow HALL B: Green GND: BLACK Max. length 5 m. | Use cables: Standard 6 wires: 0237002-xxxx |

Input/ Output specifications: Dual Hall encoded (04 in ordering example)

| Item | Specification | Comment |
|-------------|---|---|
| Description | The actuator can be equipped with two hall sensors A and B and a spindle magnet. In this way you can have pulses from the actuator when it moves. | Only use for standard actuators, with LINAK A/S Control Boxes for OpenBus™. |
| Resolution | <p>The feedback system has an 8P magnet which gives 16 shifts in pulses per spindle turn:</p> <p>3 mm pitch = 0.1875 mm per pulse 5 mm pitch = 0.3125 mm per pulse 6 mm pitch = 0.375 mm per pulse 9 mm pitch = 0.5625 mm per pulse 12 mm pitch = 0.75 mm per pulse 20 mm pitch = 1.25 mm per pulse</p> <p>See drawing for details. Tstate is minimum 5ms in all states (11.10.00.01)</p> | <p>Pulse/pause minimum 10 milli-seconds.</p> <p>On 100 mm stroke you will have the following number of pulses:</p> <p>3 mm pitch = 533 pulses 5 mm pitch = 320 pulses 6 mm pitch = 267 pulses 9 mm pitch = 178 pulses 12 mm pitch = 133 pulses 20 mm pitch = 80 pulses</p> |
| Connection | 6 pins mini-fit | Use cables: Standard 6 wires: 0237003-xxxx |
| Combination | Only standard | |

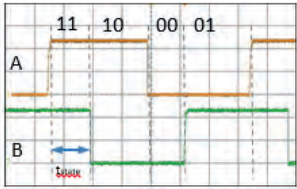

Input/ Output specifications: Hall Potentiometer feedback (1x and 2x in ordering example).

The Hall Potentiometer feedback is an option on LA23. This is especially suitable for wheelchairs or TECHLINE applications as the LINAK control boxes are not capable of handling the signal.

The main advantages are:

- Hall potentiometer is close to being an absolute positioning system
- Hall potentiometer is a long lasting and wear-resistant positioning system
- Enables compact products to have precise positioning (potentiometer increases the product potential)

Input/Output specifications: Hall Potentiometer feedback

| Item | Specification | Comment |
|---------------------|---|--|
| Description | The actuator can be equipped with an electronic circuit that gives a feedback signal when the actuator moves. | |
| Input voltage | 10 - 28 V DC Ripple down to 6 V acceptable Limit supply to 500 mA or 500 mA fuse in case of wrong polarisation. | Feedback circuit has to be powered 1 second before and after the motor runs and until the actuator has stopped. Cable dimension 0.5 mm ² AWG20 |
| Output voltage | 0 - 10 V +/- 0.5 V @ Load > 100kΩ 0 V = Fully retracted 10 V = Fully extended | Can be configured between 0 - 10 V Example: 1 V = Fully retracted 9 V = Fully extended |
| Current consumption | Current consumption is max. 40 mA @ 12 V | Also when actuator is not running. |
| Connection | Supply: White Ground: Black Signal: Violet | Use Cables: PLC/Absolute positioning 8 wires 0237003-xxxx |
| Combinations | The absolute positioning can be combined with potential free switches. But cannot be combined with relative positioning. | |



Input/Output specifications: IC (Integrated Control) option

| Item | Specification | Comment |
|--------------------------------|--|--|
| Description | Same | |
| Power supply | | |
| Input Voltage (VIN) | 12 V DC, $\pm 20\%$. 24 V DC, $\pm 10\%$. Not available with 24 / 33 V (motor type G) | Cable dimension 0.5 mm ² AWG20 |
| Current consumption @25°C | 12 V, 0.4 - 6 A depending on load 24 V, 0.2 - 3 A depending on load | Recommended fuse: 12 V version = 6AT 24 V version = 3AT |
| Standby | < 500 mW | |
| Inputs signal | | |
| Outwards direction | > 67 % of VIN = on < 33 % of VIN = off | < 3 K Ω impedance = on > 30 K Ω impedance = off |
| Inwards direction | > 67 % of VIN = on < 33 % of VIN = off | < 3 K Ω impedance = on > 30 K Ω impedance = off |
| Output signals | | |
| Signal GND | Used to minimize noise on the signal wires. Must be isolated from GROUND | |
| Actuator fully retracted (IN) | OUT voltage when active = VIN Source current max. 100 mA Voltage min = VIN - 0.5 V | |
| Actuator fully retracted (OUT) | OUT voltage when active = VIN Source current max. 100 mA Voltage min = VIN - 0.5 V | |
| FEEDBACK PWM Output | Frequency: 75 Hz ± 5 Hz Accuracy: $\pm 2\%$ Resolution: pitch divided 16 PNP source current: max. 12 mA. PWM_HIGH: VCC ± 1 V PWM_LOW: 0.5 V ± 0.5 V | tRISE < 30 μ s @ LOAD: 5 m cable 10 K Ω tFALL < 30 μ s @ LOAD: 5 m cable 10 K Ω |
| Hall Potentiometer feedback | 0 - 10 V +/- 0.5 V @ Load > 100 k Ω Resolution: pitch divided 16 0 V = Fully retracted 10 V = Fully extended Output impedance = 270 Ω | Can be configured between 0 - 10 V Example: 1 V = Fully retracted 9 V = Fully extended |
| FEEDBACK Single Hall | 16 pulses each revolution PNP source current: max. 12 mA. PWM_HIGH: VCC ± 1 V PWM_LOW: 0.5 V ± 0.5 V | |
| Cable | Connection VCC: Brown GROUND: Blue INWARDS: Black OUTWARDS: Red IN: Yellow OUT: Green Feedback: Purple Signal GND: White Max. length 5 m. | Use cables: Standard 8 wires: 0237001-xxxx |

Input / Output specifications: Hall PWM positioning feedback (3x and 4x in ordering example)

The Hall PWM positioning feedback is an option on LA23. This is especially suitable for wheelchairs or TECHLINE applications as the LINAK control boxes are not capable of handling the signal.

The main advantages are:

- Hall potentiometer is close to being an absolute positioning system
- Hall potentiometer is a long lasting and wear-resistant positioning system
- PWM is more immune to noise than Hall Potentiometer feedback
- Enables compact products to have precise positioning (potentiometer increases the product potential).

Input / Output specifications: Hall PWM positioning feedback

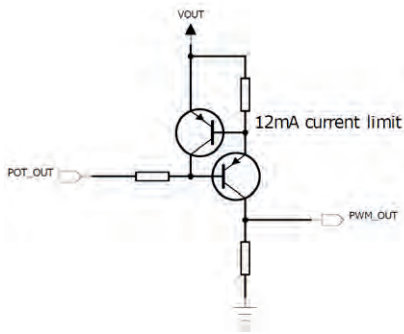
| Item | Specification | Comment |
|---------------|--|---|
| Description | The actuator can be equipped with an electronic circuit that gives a PWM position feedback. |  |
| Input Voltage | 10 - 28 V DC Ripple down to 6 V acceptable Limit supply to 500 mA or 500 mA fuse in case of wrong polarization | Feedback circuit has to be powered 1 second before motor runs and until the actuator has stopped. Cable dimension 0.5 mm ² AWG20 |
| PWM Output | Frequency: 75 Hz ± 5 Hz Accuracy: ± 2% Resolution: pitch divided 16 PNP source current: max. 12 mA. PWM_HIGH: 10 V ± 1 V PWM_LOW: 0.5 V ± 0.5 V tRISE < 30 us @ LOAD : 5 m cable 1 nF//10 KΩ tFALL < 30 us @ LOAD : 5 m cable 1 nF//10 KΩ |  |
| Current | Current consumption is max. 40 mA @12 V | Also when actuator is not running |
| Cable | Connection VCC: White PWM: Violet GND: BLACK Max. length 5m. | Use cables: Standard 8 wires: 0237001-xxxx |
| Combinations | The absolute positioning can be combined with potential free switches. But cannot be combined with relative positioning. | |



WE IMPROVE YOUR LIFE
 DESIGNED IN DENMARK
 Item No. : 2362002000050B4
 Prod. Date : 2014.06.20 S.O.6151450
 Max Load : Push/Pull 1500 N IPX4
 Power Rate: 24 V= / Max. 2.3 A
 Duty Cycle : 10%, Max. 2 min. / 18 min.

NOT TO BE OPENED BY UNAUTHORIZED PERSONNEL
 NE PAS A OUVRIER PAR PERSONNEL NON-AUTORISE

P.O.2140274-0001 MADE BY LINAK A/S DENMARK

CIN 120690



The LA23 is a small and strong push/pull actuator (up to 2500N). LA23 can be used in various applications where size is important. The actuator does have build in electrical limit switches and ground nut.

Usage:

- Duty cycle: 10 %, 2 minutes continuous use followed by 18 minutes not in use
- Usage temperature: -30 °C to +55 °C (according to ISO 7176-9)
- Storage temperature: -45 °C to +70 °C (according to ISO 7176-9)
- Fire category: Enclosure UL94-V0

 **Warnings**

- All LA23 IC (Integrated Controls) versions are not compliant for Medical use.
- Do not sideload the actuator.
- Only use the actuator within specified working limits.
- Always use steel backfixture for LA23 over 1500 N and for pull loads.
- When mounting the LA23 in the application ensure that the bolts can withstand the wear and that they are secured safely.
- Motor type A: 12 V motor
Motor type B: 24 V motor.
- If an actuator with stroke length below 50 mm is used, and the electrical end-stop switch fails, please be aware that the distance before reaching the mechanical end-stop will be prolonged. The extra distance will be 50 mm minus actual stroke length. I.e. If an actuator with 20 mm stroke length is used and the switch fails, it will travel an additional 30 mm before reaching the mechanical end-stop.
- Instruction concerning the turning of the piston rod eye. When mounting and taking into use, it is not permitted to make excessive turns of the piston rod eye. In cases where the eye is not positioned correctly, it is permitted to first screw the eye down to its bottom position, at a maximum torque of 2 Nm (1), and thereafter a maximum half turn outwards again (2).



 **Recommendations**

- Do not place load on the actuator housing and do prevent impact or blows, or any other form of stress to the housing.
- Ensure that the cable lock is mounted correctly.
- Ensure that the duty cycle and the usage temperatures for LA23 actuators is respected.
- Ensure that the cable cannot be squeezed, pulled or subjected to any other stress.

The item numbers for ordering the Cable Lock are:

- Item number: 0231007 (light grey) for one cable lock (1 piece).
- Item number: 0231037 (black) for one cable lock (1 piece). Below you see an instruction in how to mount and remove the cable lock from LA23.

a) Mount a cable lock:



Push down until the cable lock clicks into place.

b) Cable lock removal



Step 1:
Insert e.g. a screwdriver at a 45 °C angle as illustrated.



Step 2:
Turn the screwdriver to release the cable lock.



Step 3:
Now the cable lock can be removed by hand.

Note: When a cable lock has been removed, it is recommended to replace it with a new.

Connection diagrams:

Standard electrical end stop - no positioning

23XXXXXX00XXXXX

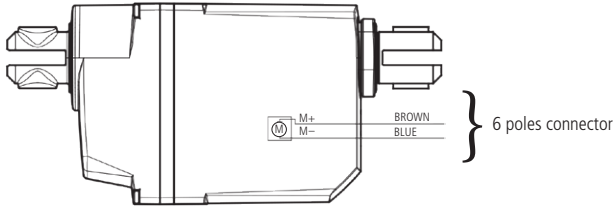

Standard electrical end stop and potential free end stop - no positioning

23XXXXXX01XXXXX

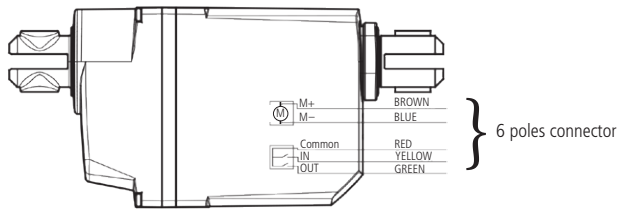

Dual Hall digital positioning

23XXXXXX02XXXXX

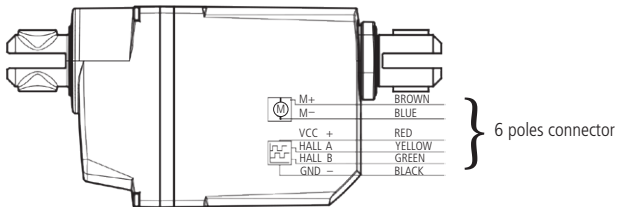

Dual Hall PNP positioning

23XXXXXX03XXXXX



Note: Connection colours only fit with "open-end" cables.



Note: If reversed driving is wanted this has to be done by using different cables.

Hall Potentiometer feedback and potential free end stop
 23XXXXXX2XXXXXX

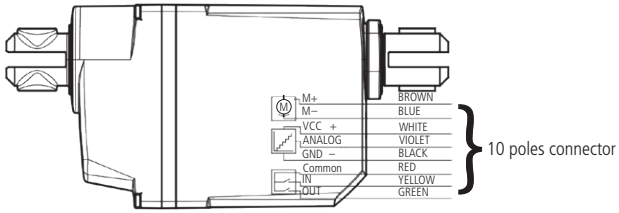

Hall Potentiometer feedback
 23XXXXXX1XXXXXX

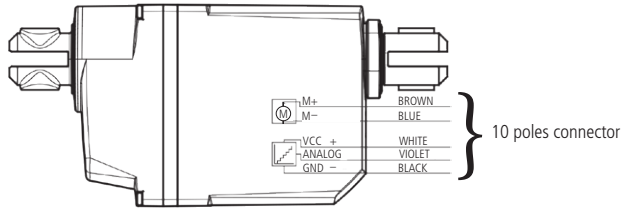

Hall PWM position feedback and potential free end stop
 23XXXXXX4XXXXXX

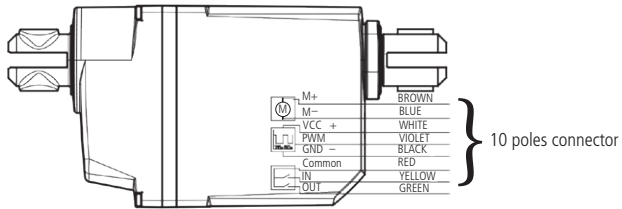

Note: Connection colours only fit with "open-end" cables.

Hall PWM position feedback
 23XXXXXX3XXXXXX

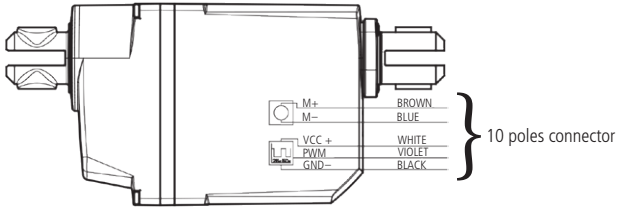

Standard Integrated Control
 23XXXXXX5XXXXXX

Integrated Control with Hall Potentiometer position feedback
 23XXXXXX6XXXXXX

Integrated Control with Hall PWM position feedback
 23XXXXXX7XXXXXX

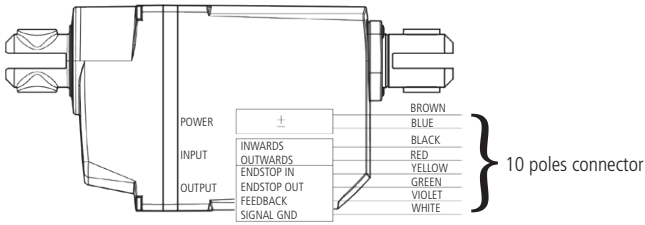

Drawing no.: 0239010-A

 LA23 with integrated control is not approved according to IEC60601-1:2005 3rd ed., ANSI / AAMI ES60601-1:2005, 3rd edition.

 Note: Connection colours only fit with "open-end" cables.

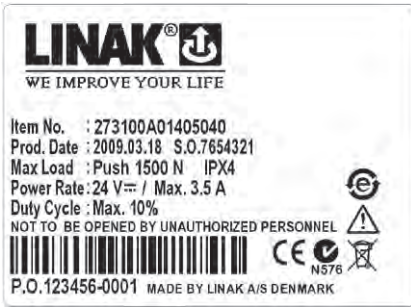

The LA27 actuator is a powerful actuator designed for a variety of medical applications. It is developed for both push and pull applications and has a very robust construction because of the ultrasonic welded plastic housing.

Usage:

- Duty cycle: 2/18; 2 minutes continuous use followed by 18 minutes not in use
- Ambient temperature: +5 °C to +40 °C (the actuator must also be at this temperature)
- LA27 is approved according to IEC 60601-1, ANSI/AAMI ES 60601-1 and CAN/CSA C-22.2 No. 60601-1
- With connection to a static voltage power supply of 33V the lifetime could be reduced to 5000 cycles (at a constant load of 6000 N).

The product is not designed for dynamic load changes (from push to pull or vice versa). If the application design requires a product with a dynamic load change capability, please contact LINAK for investigation of product feasibility or guidance.

Note: For CB6, the current will be cut off when the total current on all channels reaches approx. 5.1 to 5.4 Amp. This means that when two LA27s, running simultaneously, are connected to a CB6, they will not be able to lift the max. load mentioned under technical specifications.



Warning

- The installation of spline actuators is recommended by LINAK where possible to avoid the squeezing of body parts.
- Activation of a quick release can lead to a risk of squeezing body parts. Installation of a damper may reduce this risk.
- A quick release can accidentally be activated during mounting or maintenance. To avoid this, operators must be warned before service/mounting.
- End of life issue: defective switches - endstop:
If the electrical endstop switch for outward operation fails, it may cause a prolonged actuator stroke and in addition the customer application may collapse. To avoid this, the manufacturer must take this into account when designing and making a risk analysis.
- If electrical endstop fails to function the actuator will continue to retract or extend until mechanical endstop is reached.
The application of the customer must be able to obtain or withstand an actuator with failing electrical endstop.
Minimum length of actuator reaching mechanical endstop: BID - 5 mm.
Maximum length of actuator reaching mechanical endstop: BID + SL + 5 mm.
- If the actuator does not work as intended, there is a risk of injury. Therefore, the actuator must immediately be sent to the nearest authorised LINAK workshop for service.
- The actuator is not designed for repeated dynamic push-to-pull movement.



Recommendations

- The LA27 cable is not part of the actuator and must therefore be ordered separately.
- Once a year, the actuator must be inspected for wear and jarring sounds.
- In medical applications we recommend to use a safety nut.
- Do not expose actuators without all cables fitted to water/cleaning.
- The bolt inside the back fixture should have no thread.
- LA27 is not meant to have CB6S OBF mounted on the actuator.
CB6S OBF must be mounted separately using a bracket.
- LA27 must have a minimum installation dimension of 320 mm if control box CB6 is to be mounted on the actuator.

Instruction concerning the turning of the piston rod eye – LA27

When mounting and taking into use, it is not permitted to make excessively many turns of the piston rod eye. In cases where the eye is not positioned correctly, it is permitted to first screw the eye down to its bottom position (1), and then a maximum half turn outwards again (2).



Quick Release Ratchet Spline:



Quick Release gear with spline.
Drawing no.: LA27QR_18



Quick Release gear without spline.
Drawing no.: LA27QR_17

Mounting of the release cable:



Remove the Quick Release cover, and the cable mounting holes can be seen.



Mount the cable in one of the cable mounting holes/slots.
(If needed both holes/slots can be used)



Replace the Quick Release cover all the way so that it "clicks" into place.

Application requirements for Quick Release (QR):

To avoid damage to the LA27 with QR, it is necessary for certain parameters to be specified in the application. You should therefore be aware of the following facts when supplying an LA27QR to a customer.

Constant pressure on the actuator:

- The QR mechanism can handle a maximum of 100 N pull load otherwise it will risk jamming. This means that the actuator must always have a load applied in order not to risk jamming and ensure correct operation.
- When the QR mechanism is activated, there must be a minimum load on the actuator in order to ensure that the actuator runs inwards. This load depends on the spindle pitch:
 - 5 mm must have 750 N load.
 - 6 mm must have 500 N load.

Mechanical stop in the application:

- When the QR mechanism is activated, the actuator will run inwards until it is stopped either by the application or by the actuator. The actuator is not constructed to absorb the impact that can occur when the QR mechanism is activated and the actuator is driven into the endstop with a full load. Therefore, a mechanical stop must be built into the application to stop the movement at a distance of 5 mm before the actuator moves into endstop and blocks.

Activation of QR function:

- If the QR mechanism is activated during running of the actuator, the QR mechanism might jam. To unjam the QR mechanism, it might be necessary to first run the actuator by means of the hand control.

Use the QR function:

- LA27 with QR is designed to be used as part of the bed backrest. If the backrest needs to be brought in horizontal position as quickly as possible, the QR handle is activated to lower the backrest. When the actuator is no longer in motion, the QR handle is released.

The QR cover must be mounted:

- To ensure that the Bowden cables are fixed correctly, the QR cover must be mounted.

Quick Release cable dimensions:

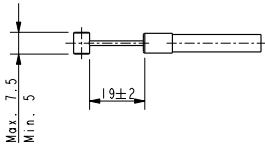
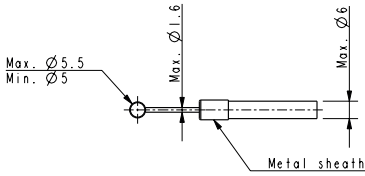

- The release cable has to be provided by the customer.
- The force required to operate the Quick Release is approx. 1 - 28 kg., depending on the actuator load.
- When operating the Quick Release function, the Quick Release must be activated all the way down and not stopped halfway!
- The Quick Release can only be ordered with 5 and 6 mm pitch.

Mounting bracket instructions:

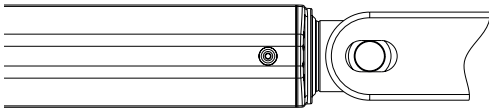

To avoid damage to the actuator when the actuator is in the "rest" position there should be no load / tension on the actuator.

LA27 without cable lock

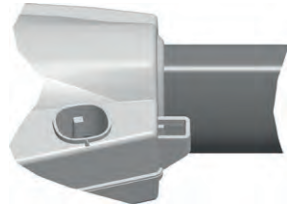

LA27 with cable lock

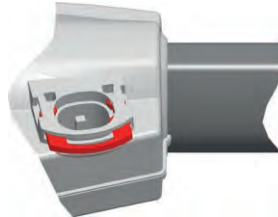





LINAK®
WE IMPROVE YOUR LIFE

Item No. : 281100+00100000
 Prod. Date : 2009.07.01 S.O.7654321
 Max Load : Push 2000 IPX1
 Power Rate : 24 V \pm / Max.2.3 A
 Duty Cycle : Max. 10%, Max. 2 min. / 18 min.
 NOT TO BE OPENED BY UNAUTHORIZED PERSONNEL



P.O.123456-0001 MADE BY LINAK A/S DENMARK

The LA28 is primarily a system actuator. The actuator is very quiet and powerful designed for use in the furniture, rehabilitation, and hospital bed line of businesses.

The actuator is also ideal for use in agricultural machinery and for a wide range of industrial applications.

Reed-switch:

Reed-switch gives a number of pulses for each rotation of the motor. These pulses are used to calculate the piston rod's position as well as to control several actuators running in parallel.

Your nearest LINAK dealer can inform the number of pulses per stroke length.

Regarding Reed-switch connection, **Figure 6.8** (LA28R)

Built-in end-stop circuit (CS28/CS28S)

In the LA28 actuator, with built-in CS28 A-, B- or C-PCB, the actuator is switched off at the end position or when overloaded.

LA28 actuator with:

- The CS28 A is standard IPX1 and is connected to a HB41 hand control with a telephone plug.
- The CS28 B is standard IPX5 and is connected to a HB41 hand control with a DIN plug. CS32 B is also available in IPX6.
- The CS28 C is standard IPX1 and is connected to an external contact or control. **See figure 6.7.**

Mechanical spline:

The splines function so that the actuator can only push, not pull. During pull in the actuator, the inner tube is lifted off the thread bush, and the actuator can therefore never pull a load, only push.

Functional test of mechanical splines:

When the piston rod is at the innermost position, it must be possible to pull it out manually to its full travel length and to press it in again without much resistance and without using the motor. If this is not possible, contact your nearest LINAK dealer.



Warning

Do only use the actuator within specified working limits.

Usage:

- Duty cycle: Max. 10 % or max. 2 min. continuous use followed by 18 min. not in use.
- Ambient temperatures: + 5 °C to + 40 °C
- Compatibility: Compatible with LINAK control boxes. Please contact LINAK.
- Approvals: IEC 60601-1, ANSI/AAMI ES60601-1 and CAN/CSA-22.2 No 60601-1



Recommendations

- LINAK control boxes are designed so that they will short-circuit the motor terminals of the actuator(s), when the actuator(s) are not running. This solution gives the actuator(s) a higher self-locking ability. If the actuator(s) are not connected to a LINAK control box, the terminals of the motor must be short-circuited to enable self-locking of the actuator.
- The maximum load in pull is 2000 N.
- Min. stroke length for the LA28 with splines is 80 mm
- The current supply to LINAK actuators must be cut off in case of overload and when the actuators reach end position.
- Ambient operating temperature is 22 °C.
- LA28 Compact cannot be used in pull applications, unless fitted with an aluminium back fixture.

Further information:

Noise level:

- LA28: dB(A) 45; measuring method DS/EN ISO 3743-1, actuator not loaded
- LA28S: dB(A) 54; measuring method DS/EN ISO 3743-1, actuator not loaded

Material:

- The piston rod eyes are "crimped" in place and cannot be unscrewed.

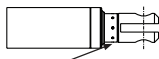

"Crimped" piston rod eye

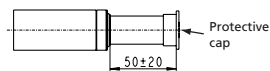

Piston rod without eye (are not tested)

7. LA28 Compact (MEDLINE® CARELINE® TECHLINE®)



LINAK®

WE IMPROVE YOUR LIFE

DESIGNED IN DENMARK

Item No. : 28110A-00100030
 Prod. Date : 2014.06.17 S.O.7854321
 Max Load : Push 2000 N IPX0
 Power Rate: 24 V = / Max. 2.3 A
 Duty Cycle : 10%, Max. 2 min. / 18 min.

NOT TO BE OPENED BY UNAUTHORIZED PERSONNEL
 NE PAS A OUVRI PAR PERSONNEL NON-AUTORISE

P.O.12345678-0001 MADE BY LINAK A/S DENMARK

The LA28 Compact is a small and powerful actuator designed for use in system solutions for healthcare equipment or industrial applications. Ideal applications are for example wheelchairs, treatment chairs, patient lifts or beds.

Usage:

- Duty cycle: Max 10 % or max. 2 min. continuous use followed by 18 min. not in use.
- Ambient temperatures: + 5 °C to + 40 °C
- Compatibility: Compatible with LINAK control boxes. Please contact LINAK.
- Approvals: IEC 60601-1, ANSI/AAMI ES60601-1 and CAN/CSA-22.2 No 60601-1

Recommendations

- LINAK control boxes are designed so that they will short-circuit the motor terminals of the actuator(s), when the actuator(s) are not running. This solution gives the actuator(s) a higher self-locking ability. If the actuator(s) are not connected to a LINAK control box, the terminals of the motor must be short-circuited to enable selflocking of the actuator.
- Min. stroke length for LA28 with splines is 80 mm
- The current supply to LINAK actuators must be cut off in case of overload and when the actuators reach end position.
- Ambient operating temperature is 22 °C.
- LA28 Compact cannot be used in pull applications, unless fitted with an aluminium back fixture.

Further information:

Noise level:

- LA28: dB(A) 45; measuring method DS/EN ISO 3743-1, actuator not loaded
- LA28S: dB(A) 54; measuring method DS/EN ISO 3743-1, actuator not loaded

Material:

- The piston rod eyes are "crimped" in place and cannot be screwed loose.



"Crimped" piston rod eye

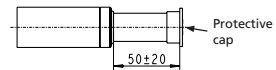

Piston rod without eye (are not tested)

8. LA29 (MEDLINE® CARELINE®)



LINAK®

Designed in Denmark

DK - 6430 Nordborg

Item No. : 291100-00200050
 Prod. Date : 2020.06.25
 Max Load : Push 6000 N
 Power Rate: 24 V=, Max.4.5 A
 Duty Cycle : 10 %, max. 2 min. / 18 min.

NOT TO BE OPENED BY UNAUTHORIZED PERSONNEL
 NE PAS OUVRI PAR DU PERSONNEL NON-AUTORISE

W/O#-0001 MADE IN DENMARK

This particular LINAK® actuator is the ideal choice in medical equipment where power and speed are required, but where space is limited.

Usage:

- Duty cycle: 10% or 2 minutes continuous use followed by 18 minutes not in use
- Usage temperature: +5 °C to +40 °C
- Storage temperature: -10 °C to 50 °C
- Compatibility: Compatible with LINAK control boxes. Please contact LINAK.
- Relative humidity: 20% to 80% - non-condensing
- Atmospheric pressure: 700 to 1060 hPa
- Height above sea level Max. 3000 meters
- A CE Declaration of Conformity has been issued

Mounting instructions:

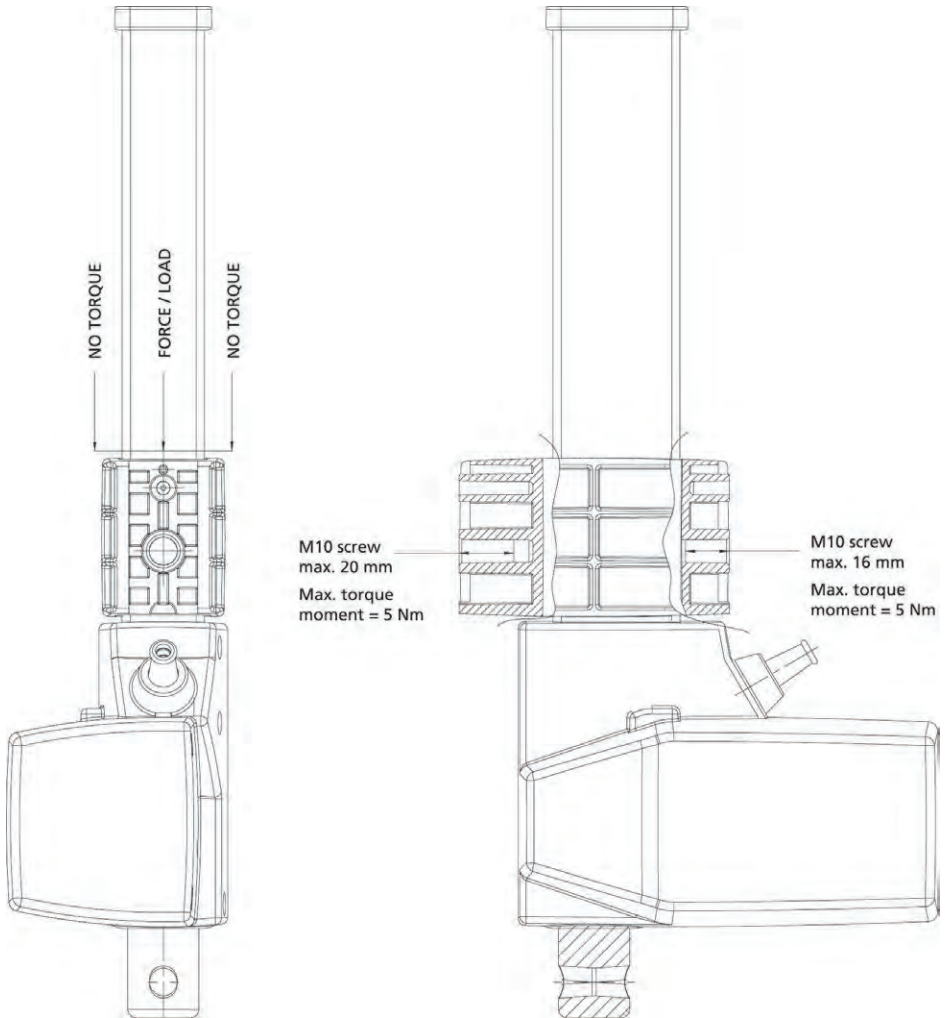

Drawing no.: LA29005A



Recommendations

- The LA29 actuator must not be used in applications where the actuator is exposed to torque moment, as this will damage the actuator.
- Do not use any other screws for the mounting brackets than those recommended by LINAK.
If longer screws are used they will come into contact with the inner parts of the actuator. This will result in an irregular operation or even damage the actuator.



Warning

- If an LA29 is used in an application with repeated dynamic push/pull, it is necessary to contact LINAK A/S in order to make a correct specification of the actuator.
Repeated push/pull movements cause extra strain on the actuator and can give safety considerations, the consequence being possible actuator damage.
- Do not sideload the actuator.
- Inspect the actuator at least once a year for wear and jarring sound.

Hall feedback

Dual Hall, encoded is used only for LINAK A/S control boxes.

Dual Hall, digital is used for non-LINAK A/S control boxes.

Feedback specification: dual Hall, digital positioning.

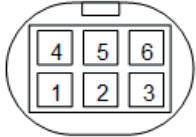
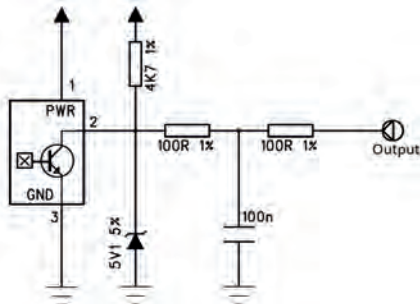
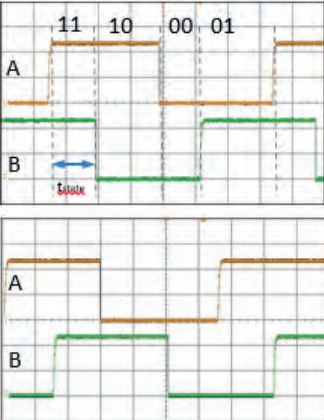
| Item | Specification | Comment | | | | | | | | | | | | |
|-------------------|---|--|-----|-------|-----|-------|----|-------|--------|-------|--------|-------|----|---|
| Pin configuration | <table border="1" data-bbox="229 199 420 383"> <tr> <td>Pin 1</td> <td>GND</td> </tr> <tr> <td>Pin 2</td> <td>VCC</td> </tr> <tr> <td>Pin 3</td> <td>M+</td> </tr> <tr> <td>Pin 4</td> <td>HALL A</td> </tr> <tr> <td>Pin 5</td> <td>HALL B</td> </tr> <tr> <td>Pin 6</td> <td>M-</td> </tr> </table> | Pin 1 | GND | Pin 2 | VCC | Pin 3 | M+ | Pin 4 | HALL A | Pin 5 | HALL B | Pin 6 | M- | Connector front view:  |
| Pin 1 | GND | | | | | | | | | | | | | |
| Pin 2 | VCC | | | | | | | | | | | | | |
| Pin 3 | M+ | | | | | | | | | | | | | |
| Pin 4 | HALL A | | | | | | | | | | | | | |
| Pin 5 | HALL B | | | | | | | | | | | | | |
| Pin 6 | M- | | | | | | | | | | | | | |
| VCC | 4-15V | Feedback circuit has to be powered 50ms before driving, and until actuator has stopped. | | | | | | | | | | | | |
| Current | Maximum 20 mA. See diagram. |  | | | | | | | | | | | | |
| Hall A/B | tstate is minimum 5 ms in all states (11,10,00,01) Duty cycle Hall A 30-70% Duty cycle Hall B 30-70% Low level <math><GND+0.5V @10k\Omega</math> and 1nF load High level $>VCC-0.5V @10k\Omega$ and 1nF load Driving out, the Hall B signal will go high when Hall A signal is low. Driving in, the Hall A signal will go high when Hall B signal is low.w |  | | | | | | | | | | | | |
| Resolution | The feedback system gives 12 state shifts per spindle turn. 3 mm pitch => 0.25 mm per shift 4 mm pitch => 0.3333 mm per shift | On 100 mm stroke you will have the following number of pulses: 3 mm pitch => 400 shifts 4 mm pitch => 300 shifts | | | | | | | | | | | | |



Designed in Denmark
DK - 6430 Nordborg
 Item No. : 3011P0-00100504
 Prod. Date : 2016.09.27
 Max Load : Push 3000 N IPX0
 Power Rate : 12 V = / Max. 16.5 A
 Duty Cycle : 10%, Max. 2 min./18 min.

NOT TO BE OPENED BY UNAUTHORIZED PERSONNEL
 NE PAS OUVRIR PAR DU PERSONNEL NON AUTORISE

W/O #2775610-0001 MADE BY LINAK A/S DENMARK

The actuator can be supplied with options such as built-in potentiometer for servo operation or an extra powerful motor for increased speed and strength (S-motor).

In addition to industrial and agricultural applications, the actuator is also ideal for positioning satellite dishes.

Usage:

- Duty cycle: 10 %, 2 minutes continuous use followed by 18 minutes not in use
- Ambient temperature: + 5 °C to + 40 °C
- Storage temperature: - 40 °C to + 70 °C
- Compatible with LINAK control boxes. Please contact LINAK.
- Approvals: IEC 60601-1, ANSI/AAMI ES60601-1 and CAN/CSA-22.2 No 60601-1

Recommendations

LINAK control boxes are designed so that they will short-circuit the motor terminals (poles) of the actuator(s), when the actuator(s) are not running. This solution gives the actuator(s) a higher self-locking ability. If the actuator(s) are not connected to a LINAK control box the terminals of the motor must be short-circuited to achieve the self-locking ability of the actuator.

Improved self-locking ability

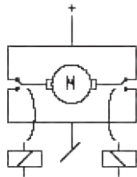

The H-bridge ensures that the motor is shorted when the relays are inactive. This is necessary to improve the self-locking of the actuator.

When using the LA30 with stereo jack plug be aware of the reversed direction of travel as standard.

The current supply to LINAK actuators must be cut off in case of overload when the actuators reach end position.

Various other information:

Noise levels:
 LA30: dB(A) 50; LA30S: dB (A) 55; LA30L: dB(A) 48.
 Measuring method DS/EN ISO 3743-1, actuator not loaded.

LA30 Actuator with potentiometer

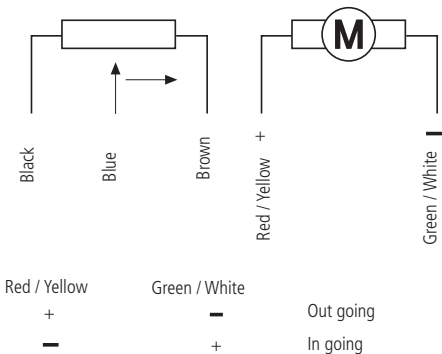

LA30 Actuator with reed (only possible with 24V L-motor)

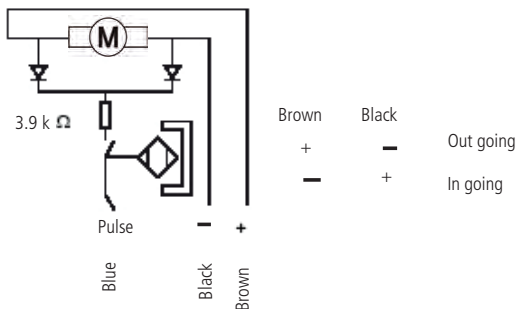

Please note that the voltage level of feedback signal depends on the actuator load.

LINAK®

WE IMPROVE YOUR LIFE

DESIGNED IN DENMARK

Item No. : 311100+2015004E

Prod. Date : 2014.06.20 S.O.6415420

Max Load : Push 6000 N IPX4

Power Rate : 24 V = / Max. 4.3 A

Duty Cycle : 10%, Max. 2 min./18 min.

NOT TO BE OPENED BY UNAUTHORIZED PERSONNEL

NE PAS A OUVRIER PAR PERSONNEL NON-AUTORISE



P.O.2140274-0001 MADE BY LINAK A/S DENMARK

The LA31 is a compact, quiet and powerful actuator designed for a variety of applications in the MEDLINE® & CARELINE® segment, such as hospital beds, couches and nursing home beds.

The standard LA31 actuator features known parts such as piston rod eye with slot, and comes in different variations with e.g. fast motor, hall positioning and emergency lowering. The LA31 actuator has exchangeable cables and is ideal in combination with OpenBus™ control boxes.

The LA31 actuator has an ingress protection of IPX6 and is available in version with up to 6000N in push or 4000N in pull.

Usage

- Duty cycle: Max 10 % or 2 minutes continuous use followed by 18 minutes not in use
- Cycles: The LA31 life cycle test has been performed with a stabilised power supply (10 % duty cycle) on a 200 mm stroke actuator at max. load for 10,000 cycles (at ambient temperature)
- Ambient temperature: + 5 °C to + 40 °C
- Compatibility: Compatible with LINAK control boxes. Please contact LINAK
- Approvals: IEC 60601-1, ANSI/AAMI ES60601-1 and CAN/CSA-22.2 No 60601-1

The product is not designed for dynamic load changes (from push to pull or vice versa. If the application design requires a product with a dynamic load change capability, please contact LINAK for investigation of product feasibility or guidance.

Exchangeable cables:

 When using LA31 with reed feedback in combination with the following control boxes: CB8, CB14 and JUMBO control boxes, please use the cable type 10A31-X5XXXXX-XXXX-X to avoid control box damage.

Recommendations

- The release cable has to be provided by the customer.
- The design of the release cable has to be as specified.
- It is important to observe the max. active (the moving part of the cable) cable length of 12 mm. Do not pull more than this length otherwise the QR will be damaged!
- The force required to operate the Quick Release is approx. 5 kg.
- When more than the recommended 5 kg force is used to activate the QR, more friction will be created in the internal actuator/QR mechanism. This means that a greater load will be required to ensure successful operation.
- The QR cover is supplied attached to the actuator but not mounted.
- LA31 with external quick release, types I, K, L, and M can maximum pull 200 N.
- The necessary release force on an actuator with 5 mm pitch is 75 kg for 6 mm pitch = 50 kg.
- It is not possible to combine splines with the external quick release.
- LA31 with quick release is always with brake (push).
- The flexible back fixtures (05 or 06) must be standard when the LA31 is equipped with quick release.
- LA31 with brake. An LA31 brake in a push application brakes actively when the actuator moves in an inward direction. The same applies to an actuator mounted with a brake in a pull direction. It brakes in an outward direction. Under this condition the standard motor uses up to 4 Amp. and the fast motor uses up to 6 Amp. (Measured after 5 cycles at normal room temperature). Therefore if the LA31 with brake is used together with a CB7 it is important that the current cut-off limit of the control box is higher than the used Amp. i.e. not lower than 4 Amp. LA31 with brake cannot be combined with CB9/CB7 with emergency lowering. For all LA31 actuators with brake self-locking ability up to max. load it is only possible in one direction: push or pull.
- The LA31 actuator must not be exposed to more than 4000 N in pull. In applications where misalignments may occur the normal back fixture can take max. 1500 N in pull whereas the flexible back fixture can take up to 4000 N in pull. The actuator must be mounted at right angles (90 °C) to it is fixing/load (max. 1.5 °C deviation)
- LA31 actuators with protection class IPX6 must be mounted with the screw holes mounted facing downwards. To ensure that any water remaining from cleaning / washing is not collected in the screw holes.

Correct mounting:

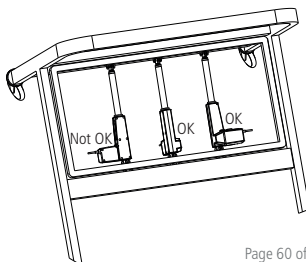

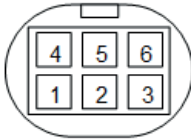
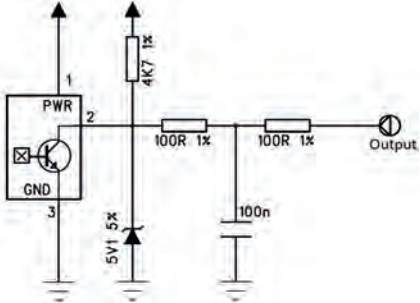
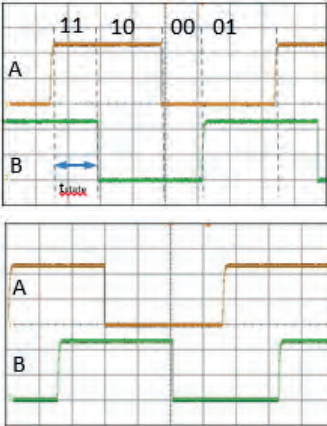
| Item | Specification | Comment | | | | | | | | | | | | |
|-------------------|--|--|-----|-------|-----|-------|----|-------|--------|-------|--------|-------|----|--|
| Pin configuration | <table border="1" data-bbox="228 81 418 264"> <tr><td>Pin 1</td><td>GND</td></tr> <tr><td>Pin 2</td><td>VCC</td></tr> <tr><td>Pin 3</td><td>M+</td></tr> <tr><td>Pin 4</td><td>HALL A</td></tr> <tr><td>Pin 5</td><td>HALL B</td></tr> <tr><td>Pin 6</td><td>M-</td></tr> </table> | Pin 1 | GND | Pin 2 | VCC | Pin 3 | M+ | Pin 4 | HALL A | Pin 5 | HALL B | Pin 6 | M- | Connector front view:  |
| Pin 1 | GND | | | | | | | | | | | | | |
| Pin 2 | VCC | | | | | | | | | | | | | |
| Pin 3 | M+ | | | | | | | | | | | | | |
| Pin 4 | HALL A | | | | | | | | | | | | | |
| Pin 5 | HALL B | | | | | | | | | | | | | |
| Pin 6 | M- | | | | | | | | | | | | | |
| VCC | 4-15V | Feedback circuit has to be powered 50ms before driving, and until actuator has stopped. | | | | | | | | | | | | |
| Current | Maximum 20 mA. See diagram. |  | | | | | | | | | | | | |
| Hall A/B | tstate is minimum 5 ms in all states (11,10,00,01) Duty cycle Hall A 30-70% Duty cycle Hall B 30-70% Low level <GND+0.5V @10kΩ and 1nF load High level >VCC-0.5V @10kΩ and 1nF load Driving out, the Hall B signal will go high when Hall A signal is low. Driving in, the Hall A signal will go high when Hall B signal is low. |  | | | | | | | | | | | | |
| Resolution | The feedback system gives 12 state shifts per spindle turn. 3 mm pitch => 0.25 mm per shift 4 mm pitch => 0.3333 mm per shift | On 100 mm stroke you will have the following number of pulses: 3 mm pitch => 400 shifts 4 mm pitch => 300 shifts | | | | | | | | | | | | |

Hall potentiometer

Input/output specifications: absolute positioning

| Item | Specification | Comment |
|---------------------|---|--|
| Description | The actuator can be equipped with an electronic circuit that gives an analog feedback signal when the actuator moves. | |
| Input voltage | VCC = 12 - 25 VDC | Feedback circuit to be powered 1 second before motor runs, and until 1 second after the motor has stopped. Cable dimension: 2 x AWG18 and 4 x AWG26 |
| Output voltage | POT OUT 0 - 5V 0 - 10V 0V = Fully retracted 10V = Fully extended | +/- 0.5V @ Load > 100K Ω |
| Current consumption | Current consumption is max.40 mA. | Also when actuator is not running |

Connection diagram:

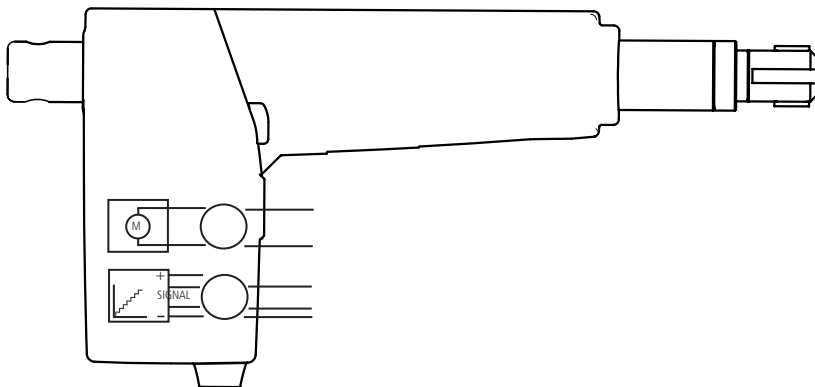

Cable connections:

| Mini-Fit Connector | Definitions |
|--------------------|-------------|
| Pin 1 | N / A |
| Pin 2 | VCC |
| Pin 3 | M + |
| Pin 4 | POT-OUT |
| Pin 5 | GND |
| Pin 6 | M - |

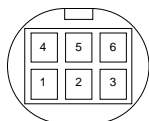

Connector front view

Mounting bracket instructions:

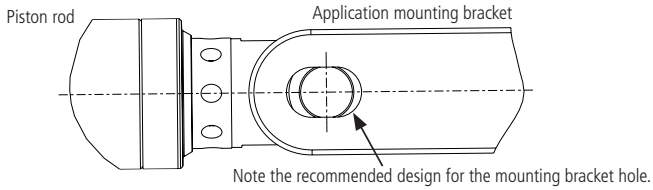

- LA31 with internal quick release types A and B is not designed for use in pull.
- The necessary release force on an actuator with 5mm pitch is 75 kg for 6 mm pitch = 50 kg.
- LA31 with quick release is always with brake (push).
- The flexible back fixtures (05 or 06) must be standard when the LA31 is equipped with quick release.
- When operating the QR function of QR types A and B, the QR must be activated all the way down. Otherwise the QR will no longer function.

Mounting of the release cable:

Fig. 1. Removal of QR cover.

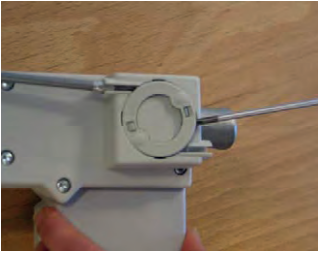

Use only light pressure near the snap-on flanges to lift the cover.

Fig. 2. QR cover removed.



Here the cover is removed and the cable mounting can be seen.

Fig. 3. Replacement of QR cover.



Use only a small amount of pressure to replace the QR cover.

Max. angle of movement:

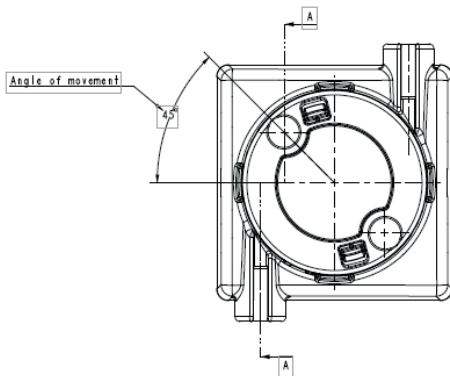

Note: To ensure operation the Quick Release must be rotated 45 °C (max.) due to tolerance/load variation. Some units may operate before 45 °C is reached. To avoid damaging the QR, it should not go above 45 °C.

Drawing no.: 031944

Warning

- The actuator must not be used in pull applications when the Quick Release is activated, as the risk of personal injury can arise.
- Bowden cable must click twice, in order to be locked sufficiently.
- The actuator must not be used in pull applications when the Quick Release is activated, as the risk of personal injury can arise.
- Bowden cable must click twice, in order to be locked sufficiently.
- Do not sideload the actuator.
- Inspect the actuator minimum once a year for wear and jarring sound.
- The actuator is not designed for repeated dynamic push-to-pull movement.



LA31 actuators for patient hoists are marked with a label to ensure the user is aware that it is not permitted to handle the patient hoist by pulling the actuator or otherwise expose it to side forces.

LA31 with mechanical end stop - a first failure safe option:

In many applications our customers have approvals according to EN 60601-1.

The typical applications can be beds, massage couches etc.

In the norm, EN 60601-1, it is mentioned that the application must be first failure safe.

The manufacturer is responsible for making a risk analysis in order to check this. If a risk is identified it is the manufacturer of the application who makes sure that the risk is eliminated.

Normally the result of this risk analysis will state that the end stop switch in the LA31 would be questioned: Is this switch first failure safe?

The answer to this will be: No, a switch cannot be first failure safe. - In practical life we have discovered only very few defect switches.

Ask the customer: - What was the result of your risk analysis when you achieved the EN 60601-1 approval on your application?

There are several ways that an application can be made first failure safe:

- Use a mechanical stop in the application
- Use of a mechanical end stop in LA31 - is a possible option.
- Use an SLS (safety limit switch) in connection with the actuator.
- As a special solution we can offer LA31 with mechanical end stop with the same installation dimension as a standard LA31.

Contact LINAK A/S for further information if you need this solution.

Warnings

To avoid damage to the actuator

When the application is in the "rest" position there should be no load/tension on the actuator.

If electrical end stop fails to function the actuator will continue to retract or extend until mechanical end stop is reached.

The application of the customer must be able to obtain or withstand an actuator with failing electrical end stop.

Minimum length of actuator reaching mechanical end stop: nominal BID - 7 mm.

Maximum length of actuator reaching mechanical end stop: nominal BID + nominal SL + increase + 7 mm.

LA31 with manual lowering

The purpose of the ML (Manual Lowering) is in case of a power failure, to be able to mechanically lower a patient by turning the ML part in the clockwise direction until the actuator is fully lowered.



Recommendations:

- An addition of 35 mm to installation dimension compared to standard (with spline)
- Only for push applications
- Use spline actuators
- Cannot be retro fitted



WE IMPROVE YOUR LIFE
DESIGNED IN DENMARK
 Item No. : 34420K-301502A0
 Prod. Date : 2014.06.20 S.O.6125402 
 Max Load : Push 3000 N
 Power Rate: 24 V= / Max. 4 A
 Duty Cycle : 10 %, Max. 2 min./18 min. IPX4
 NOT TO BE OPENED BY UNAUTHORIZED PERSONNEL
 NE PAS A OUVRIR PAR PERSONNEL NON -AUTORISE 

 P.O.2140274-0001 MADE BY LINAK A/S DENMARK  

LA34 is a technological state-of-the-art actuator that, due to its innovative construction can push up to 10,000 N at a speed of 5 mm/sec. and with a current consumption of approx. 7 Amp. The strong LA34 actuator is made in a low weight composite material. Its compact design, the outstanding performance and a wide range of safety options makes LA34 the right choice for a variety of medical and industrial applications. The LA34 24V actuator is approved according to IEC 60601-1, ANSI / AAMI ES60601-1, and CAN / CSA-22.2 No 60601-1.

Reed-switch:

The Reed-switch gives a number of pulses for each rotation of the motor. These pulses are used to calculate the piston rod's position as well as to control several actuators running in parallel.

Your nearest LINAK dealer can inform the number of pulses per stroke length.

Regarding Reed-switch connection, **see Figure 6.10.**

Options:

- Mechanical spline: When using the actuator in a vertical position, the force needed to activate the mechanical spline is maximum 60 N + the weight of the application. To reengage the spline function, a force of maximum 60 N is needed. Same installation dim. as standard actuator.
- A modified Bowden cable holder is available (as a special article), with better cable alignment and improved guidance of the cables.
- Electric spline: When using the actuator in a vertical position, the force needed to activate the electric spline is maximum 100 N + the weight of the application. To reengage the spline function, a force of maximum 100 N is needed.

Usage:

- Duty cycle: 2/18 – 2 minutes continuous use followed by 18 minutes not in use
- Ambient temperature: + 5 °C to + 40 °C
- Compatibility: Compatible with LINAK control boxes. Please contact LINAK
- Approvals: IEC60601-1, ANSI / AAMI ES60601-1 and CAN / CSA-22.2 No 60601-1 for LA34 24V zinc and composite versions.



Recommendations

- Power supply without current cut-off can cause serious damage to the actuator if mechanical stop is encountered or the actuator movement is blocked in another way.
- LINAK control boxes are designed so that they will short-circuit the motor terminals (poles) of the actuator(s) when the actuator(s) are not running. This solution gives the actuator(s) a higher self-locking ability. If the actuator(s) are not connected to a LINAK control box the terminals of the motor must be short-circuited to achieve the self-locking ability of the actuator.



Warning

An LA34 actuator is not designed for repeated dynamic push-to-pull movements. This cause extra strain to the actuator and can give safety considerations, the consequence being possible damage to the actuator. Therefore, if repeated dynamic push-to-pull movements are essential for the application, perform tests to validate the performance and use a steel piston rod eye (contact LINAK A/S).



LA34 actuators for patient hoists are marked with a label to ensure the user is aware that it is not permitted to handle the patient hoist by pulling the actuator or otherwise expose it to side forces.



Tests show that uneven running can occur when retracting the LA34 composite actuator with a low load below 500N. This has no impact on the safety of the actuator and is caused by internal frictions.

If the LA34 actuator is used in connection with a non-LINAK power supply the system must be equipped with current trip cut-off.

Adjustment of the installation dimension N

As standard the installation dimension on the LA34 actuator can be manually adjusted by +4 / -0 mm (not possible for mechanical splines). The adjustment of the installation dimension must only be made without use of tools only, (or hand). It is not allowed to use tools to adjust the installation dimension of the LA34 actuator as there is a risk that the inner tube may be unscrewed.

Hall

The Hall principle is very similar to the Reed principle. It is a control box, which based on Hall signals, can decide whether the actuator runs out or in. Hall, however, can detect whether the actuator runs in or out. The number of pulses is like Reed. Hall and Reed are placed opposite the potentiometer on the actuator's worm wheel. Therefore, it is not suitable for use in quick release /free wheelingactuators. **see figure 10.**

Potentiometer

The potentiometer function is mechanically attached to the spindle and registers the number of spindle revolutions. The signal from the potentiometer is measured in Ohm, where the lowest value is measured when the actuator has been run into inward switch stop. The potentiometer is a 10 - turn and therefore it is dependent on the stroke length/spindle pitch. **see figure 6.5**

Mechanical spline:

The splines function so that the actuator can only push, not pull. During pull in the actuator, the inner tube is lifted off the thread bush, and the actuator can therefore never pull a load, only push. See **Figure 8**.

Functional test of mechanical splines:

When the piston rod is at the innermost position, it must be possible to pull it out manually to its full travel length and to press it in again. When used in a vertical position the force needed to activate the mechanical spline is maximum 60 N + the weight of the application. To reengage the spline function, a force of maximum 60 N is needed. If this is not possible, contact your nearest LINAK dealer.

Electrical splines:

In the rear fixture on the actuator, a microswitch is fitted, which turns off the motor, if the actuator is exposed to pull forces.

Functional test of electrical splines

It is important that the actuator is correctly fixed with regard to the section on page 11. For mounting, see **Figure 7**.

When the actuator is correctly fixed/mounted, the inward movement of the piston must stop, when the actuator is pulled or the movement is blocked, so that the back fixture is not put under undue stress/tension.

Quick Release

LA34 (34xxxF/H) is equipped with a function which permits operation of the actuator should the power source fail. Condition for functioning: the actuator must be loaded in push direction (LA34xxxF) or pull direction (LA34xxxH).



Warning

- If the actuator does not work as described above, the risk of injury due to squeezing can arise. Therefore, the actuator must be sent immediately for service at the nearest, authorised LINAK workshop.
- The actuator must not be used in pull applications when the Quick Release is activated, as the risk of personal injury can arise.
- Do only use the actuator within specified working limits.

Activation of Quick Release

Pull the release handle in the direction of the piston rod eye (outwards), the harder you pull the button the quicker the actuator runs down.

When releasing the button the emergency lowering stops immediately. The emergency lowering is activated as long as the load on the actuator is above 100 - 150 kg. The actuator is ready for normal use when the emergency lowering is finished.

Safety device regarding functional failure of the nut (Safety nut):

The LA34 has a built-in safety nut in push as standard and is available with a safety nut in pull as an option. Actuators with safety nut in push can only function when used in push applications. The safety nut comes into operation should the main nut fail.

Afterwards it is only possible to drive the actuator into the innermost position. Safety nut in pull is for pull applications and works the opposite way as described above. Thereafter, the actuator will not function any more and must be sent for service.

Built-in end-stop circuit



In the actuators mentioned the end-stop switch is part of the actuator construction. Each time the actuator reaches end-stop position, the switch is activated and the current is cut off.

LINAK® 

WE IMPROVE YOUR LIFE
DESIGNED IN DENMARK

Type : 400401000A000B26+32CB127522002
Item No. : J08477
Prod. Date : 2014.12.18
Max Load : Push 8000-5500 N IPX6
Power Rate: 24 V= / Max. 6.4 A
Duty Cycle : 10%, Max. 2 min. / 18 min.

NOT TO BE OPENED BY UNAUTHORIZED PERSONNEL
NE PAS OUVRIR PAR DU PERSONNEL NON AUTORISÉ

W/O #1234567-0001 MADE BY LINAK A/S DENMARK

The LA40 is a low noise and powerful actuator which is available in a 1500N, 4000N, 6000N and an 8000N version. Based on the extensive knowledge and experience from previous actuator families, LINAK has developed new gear and braking principles that improve the efficiency of the new LA40. These innovative solutions are covered by several patents.

Usage:

- Duty cycle: 10 %, 2 minutes continuous use, followed by 18 minutes not in use
- Usage temperature: 5 °C to 40 °C
- Compatibility: CBHA220A software 30002001 version 1.08
In combination with TD4 software version 30002001, Version 1.21
- Relative humidity: 20% to 80% - non-condensing
- Atmospheric pressure: 700 to 1060 hPa (3000 m)
- Approvals: Will be approved according to EN60335-1

The product is not designed for dynamic load changes (from push to pull or vice versa. If the application design requires a product with a dynamic load change capability, please contact LINAK for investigation of product feasibility or guidance.



Please note that extension of the built-in dimension may reduce the safety factor.



If electrical endstop fails to function the actuator will continue to retract or extend until mechanical endstop is reached.

The application of the customer must be able to obtain or withstand an actuator with failing electrical endstop.

Minimum length of actuator reaching mechanical endstop: BID - 7 mm.

Maximum length of actuator reaching mechanical endstop: BID + SL + 7 mm.



Recommendations

- Power supply without current cut-off can cause serious damage to the actuator if a mechanical stop is encountered or the actuator movement is blocked in another way.
- Connection bolts must be dimensioned so that they have the necessary strength and tolerance in order to obtain the minimum safety factor according to the requirements of the authorities.
- The actuator must not be subject to a side load, as this can cause bending / collapse of the actuator. The actuator must never be used as a handle.
- The actuator must not be subject to off-centre loading, as this can cause bending / collapse of the actuator.
- The actuator must not be subject to impact, or any form of stress to the casing.
- The actuator must not be subject to overload, as this can reduce the lifetime of the actuator and in the worst case cause damage to the actuator.
- The actuator must never be used in dynamic pull applications, as this can cause collapse.
- Only use the actuator within the specifications.
- Connection bolts and brackets are to be inspected in connection with service, and must be replaced if there are signs of wear.
- Ensure that the cable lock is mounted correctly.
- Ensure that the duty cycle and the usage temperatures for LA40 actuators are respected.
- Ensure that the cable cannot be squeezed, pulled or subjected to any other stress.
- The LA40 is not suitable for use in outdoor applications where it can be exposed to sun and rain.



Warning

- The installation of spline actuators is recommended by LINAK where possible to avoid the squeezing of body parts.
- End of life issue: defective switches - endstop:
If the electrical endstop switch for outward operation fails, it may cause a prolonged actuator stroke and in addition the customer application may collapse. To avoid this, the manufacturer must take this into account when designing and making a risk analysis.

Instruction concerning the turning of the piston rod eye

When mounting and taking into use, it is not permitted to turn the piston rod eye several times. In cases where the eye is not positioned correctly, the eye must be screwed to its bottom position (1) and then maximum half a turn outwards again (2).

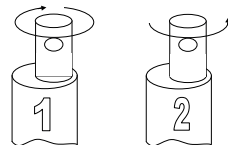

Mounting bracket instructions

To avoid damage to the actuator, it is important that the actuator drives to the application endstop position and continues to operate in the groove until it activates the electric actuator endstop.



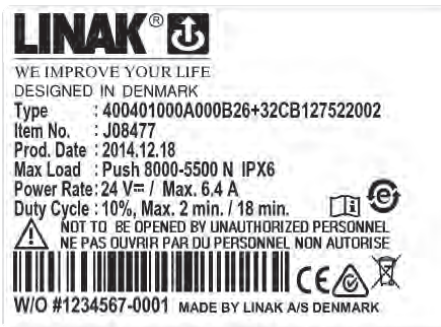

The LA40 is a low noise and powerful actuator which is available in a 1,500 N, 4,000 N, 6,000 N and an 8,000 N version.

With the LA40, LINAK offers a new durable actuator with high speed/high performance and mechanical endstop for first failure safety making it the right choice for the future market. The LA40 versions are rated up to IPX6 Washable DURA™, except for the LA40 PL version which is rated up to IPX6.

The LA40 8,000 N is available in three versions:

- Standard
- High Performance (HP)
- Patient Lift (PL)

Usage:

- Duty cycle: 10 %, 2 minutes continuous use, followed by 18 minutes not in use
- Usage temperature: 5 °C to 40 °C
- Storage temperature: -10 °C to 50 °C
- Compatibility: Compatible with LINAK control boxes. Please contact LINAK
- Relative humidity: 20% to 80% - non-condensing
- Atmospheric pressure: 700 to 1,060 hPa
- Height above sea level Max. 3,000 meters
- Flammability rating: UL94V-2
- Approvals: IEC 60601-1, ANSI/AAMI ES60601-1, CAN/CSA-C22.2 No 60601-1

Warning

- The installation of spline actuators is recommended by LINAK where possible to avoid the squeezing of body parts.
- The safety option manual lowering makes it possible to turn the inner tube down by hand in emergency cases or if electrical power is not available.
- Activation of a quick release can lead to a risk of squeezing body parts. Installation of a damper may reduce this risk.
- A quick release can accidentally be activated during mounting or maintenance. To avoid this, operators must be warned before service/mounting.
- End of life issue: defective switches - endstop:
 - If the electrical endstop switch for outward operation fails, it may cause a prolonged actuator stroke and in addition the customer application may collapse. To avoid this, the manufacturer must take this into account when designing and making a risk analysis.
 - If electrical endstop fails to function the actuator will continue to retract or extend until mechanical endstop is reached. The application of the customer must be able to obtain or withstand an actuator with failing electrical endstop. Minimum length of actuator reaching mechanical endstop: BID - 7 mm. Maximum length of actuator reaching mechanical endstop: BID + SL + 7 mm.
- If the actuator does not work as intended, there is a risk of injury. Therefore, the actuator must immediately be sent to the nearest authorised LINAK workshop for service.
- The actuator is not designed for repeated dynamic push-to-pull movement.

Recommendations

- Power supply without current cut-off can cause serious damage to the actuator if a mechanical stop is encountered or the actuator movement is blocked in another way.
- Connection bolts must be dimensioned so that they have the necessary strength and tolerance in order to obtain the minimum safety factor according to the requirements of the authorities.
- The actuator must not be subject to a side load, as this can cause bending/collapse of the actuator. The actuator must never be used as a handle.
- The actuator must not be subject to off-centre loading, as this can cause bending/collapse of the actuator.
- The actuator must not be subject to impact, or any form of stress to the casing.
- The actuator must not be subject to overload, as this can reduce the lifetime of the actuator and in the worst case cause damage to the actuator.
- Only use the actuator within the specifications.
- Connection bolts and brackets are to be inspected in connection with service, and must be replaced if there are signs of wear.
- Ensure that the cable lock is mounted correctly.
- Ensure that the duty cycle and the usage temperatures for LA40 actuators are respected.
- Ensure that the cable cannot be squeezed, pulled or subjected to any other stress.
- The LA40 is not suitable for use in outdoor applications where it can be exposed to sun and rain.
- LA40 with mechanical endstop - a first failure safe option:

In many applications customers have approvals in accordance with EN 60601-1. The typical applications are beds, massage couches etc. The norm EN 60601-1 states that the application must be first failure safe. The manufacturer has the responsibility of carrying out a risk analysis in order to check this. If a risk is identified, the application manufacturer must ensure that this risk is eliminated. A switch cannot be first failure safe.



Recommendations

- Patient lift and stand aids:
 - Long installation dimension: must always be used for patient lifts.
 - Do not hold the inner or outer tube while the actuator is running. There can be a risk of squeezing between the manual lowering unit and the outer tube.
 - Always use the ratchet spline functions for patient lifts.
- LA40 8,000 N PL actuators for patient lifts are marked with a label to ensure that the user is aware that it is not allowed to pull the actuator or otherwise expose it to side forces when handling the patient lift.
- If the actuator is used in dynamic push and pull, noise and extended play in axial direction may occur during lifetime due to wear and tear.
- The max. pull load and guidelines for safety arrangements in accordance with the User Manual must be respected.
- If the damper is activated too frequently, there is a risk of reduced damping effect.
- The damper functionality is not designed to work in environments with low temperatures (below 0 °C).
The actuator may become defective and/or the damping effect may be reduced.
- If the load on the actuator is too low, the damper will not be activated and the actuator will work with quick-release effect only.
- If the load on the actuator is too low and the QR is activated (i.e. when a caregiver uses QR for cleaning purposes), high clicking sounds may occur during the actuator lowering. This is caused by the damper functionality and does not mean any actuator or damper damage.



Instruction concerning the turning of the piston rod eye:

When mounting and taking into use, it is not permitted to turn the piston rod eye several times. In cases where the eye is not positioned correctly, the eye must be screwed to its bottom position (1) and then maximum half a turn outwards again (2).

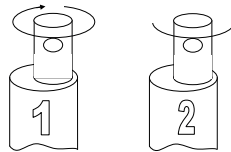

Mounting bracket instructions:

To avoid damage to the actuator, it is important that the actuator drives to the application endstop position and continues to operate in the groove until it activates the electric actuator endstop.

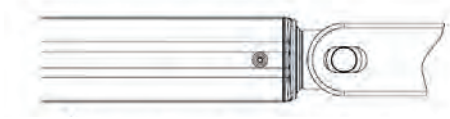

To avoid accumulated water inside the quick release lid (see illustration to the right) it is recommended not to mount the LA40 quick release actuator with the lid in downward position.

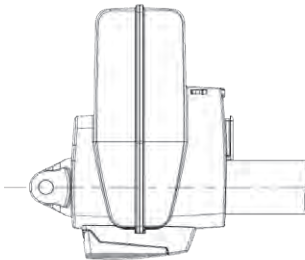

Manual lowering:

The picture to the right illustrates the manual lowering procedure.

In case of a power failure, it is possible to mechanically lower a patient placed in a patient lift. When turning the manual lowering handle clockwise, the actuator can be moved fully inwards.



Spline:

- Required minimum push load 200 N on the actuator to allow inward movement (otherwise the spline can be activated) (picture 1).
- Required activation pull force during inward operation: <100 N to activate the ratchet spline to avoid squeezing situations (picture 2).
- For QR versions: Force required to manually activating spline (actuator not in operation); Static pull force = 300 - 550 N. For manual pull out (extend) of the inner tube (picture 3).

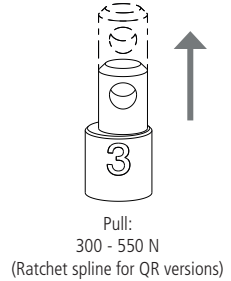
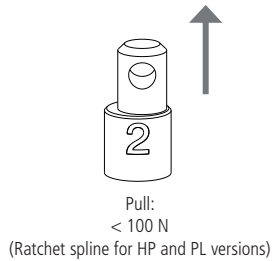
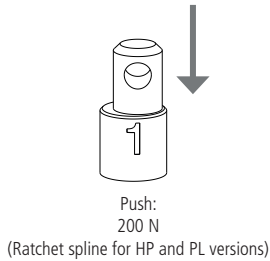
**Damper function:**

The LA40 QR can be equipped with an internal damper mechanism. The damper inside the LA40 provides a slower lowering speed, compared to the normal QR lowering speed which is faster.

When the QR is activated, with the existence of a certain amount of push load, the spindle rotation speed will engage the Damper mechanism and will start a slower lowering.

The speed when the damper is activated will be load dependent and the damper is only acting as an extra friction when QR-lowering is activated.

Mounting of the quick release cable:

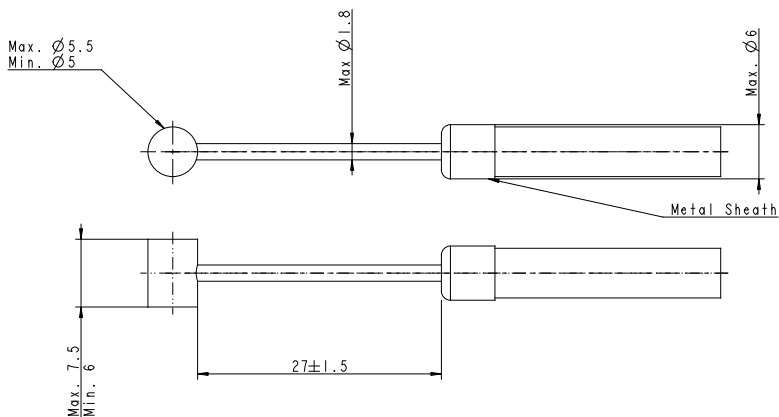

Cable dimensions inside the quick release housing required to ensure correct operation.

Drawing no.: 0404016-1

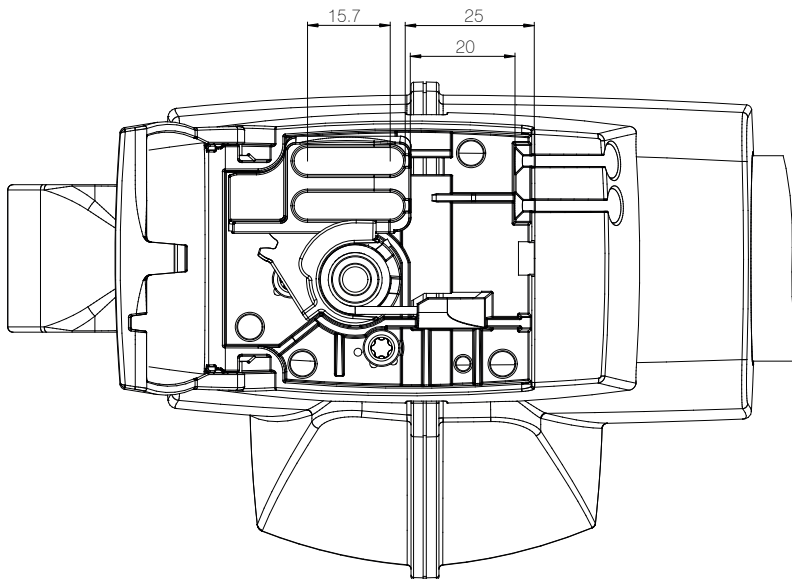

Quick release mechanism in its nonactivated position.

Note that the cable fixture has a maximum travel distance of 20 mm until it hits the housing wall that acts as end stop.

The application design must ensure that the quick release cable cannot be pulled the full travel to end stop with excessive pull force. This is to protect the quick release unit.

Drawing no.: 0404017-1

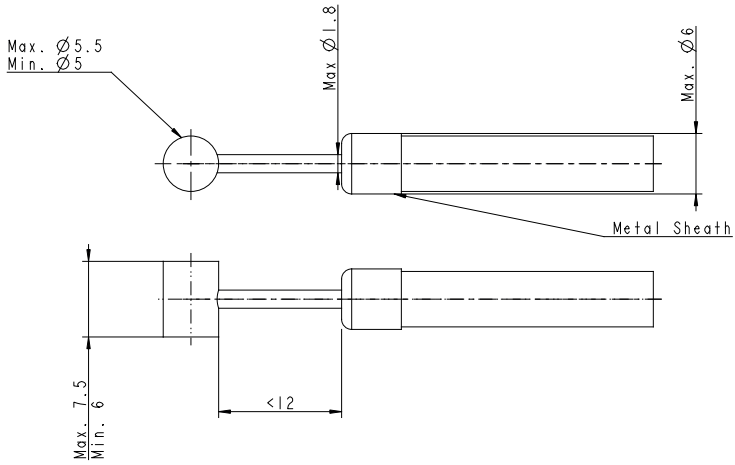

When the cable is pulled, the quick release is activated with certainty when the cable has less than 12 mm travel distance to give.

Drawing no.: 0404016-2

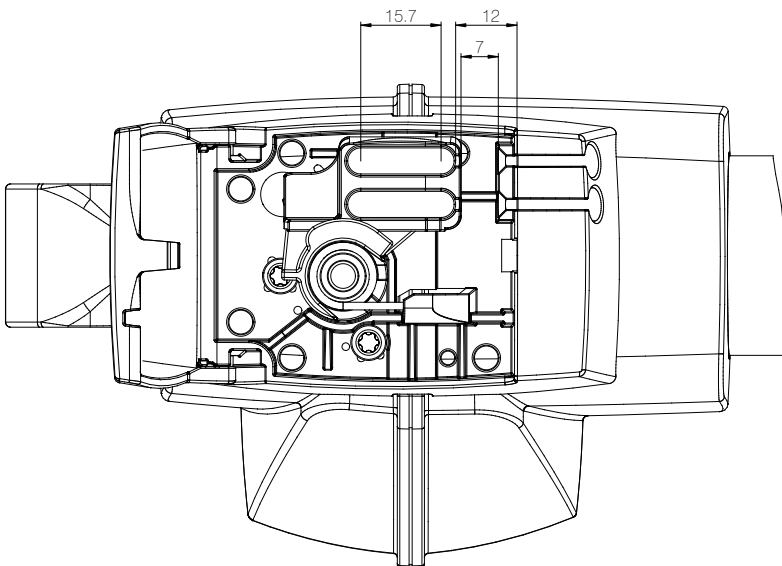

At the point when the quick release is activated with certainty, the cable fixture has 7 mm travel left before it hits the end stop.

Drawing no.: 0404017-2

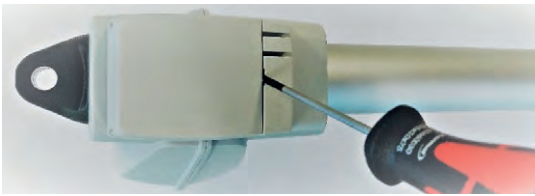

Make sure that the actuator is unloaded at its fully retracted position!

Open the quick release lid using a flat-head screwdriver. Push and tip to release the lock.

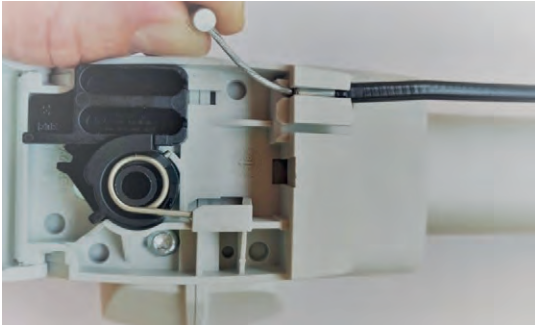

Run the cable through the slot of the mounting hole for the jacket collar. Pull the cable until the jacket collar is in place.

If needed, support the cable jacket by holding it so that it stays in the mounting hole for the jacket collar.

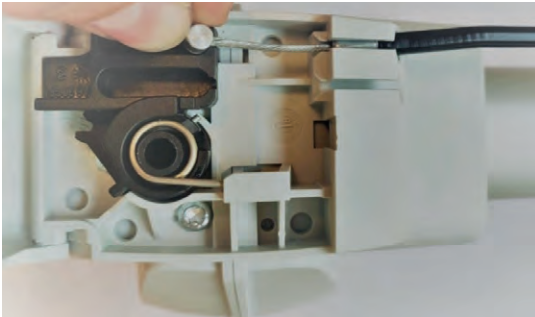

Place the cylindrical cable end in the cable fixture.

Repeat the procedure if two release cables are used.



If the cable is equipped with a barrel adjuster mechanism at the opposite cable end, then use it to adjust the cable to the recommended cable length. See drawing no. 0404016-1.

Verify that the quick release mechanism is completely released when the cable is not pulled. Also verify that the cable can be pulled almost to the endstop.

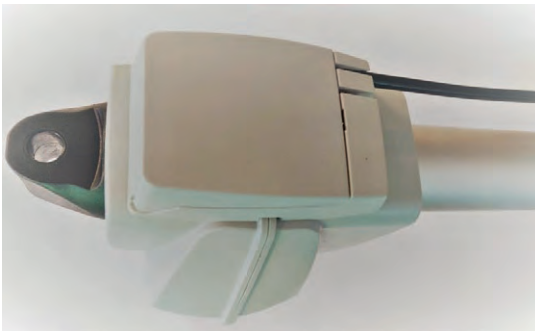

Close the lid.

Now test that the quick release is functional by pulling the cable with the actuator extracted.

Approximate force required to operate the quick release:

55 N at an actuator load of 750 N

90 N at an actuator load of 4000 N

When operating the quick release function, the quick release must be activated all the way down and not stopped halfway.

Feedback specifications

| E2 (Signal) | |
|-------------|------------------|
| 1 | NC |
| 2 | COMMON EOS* |
| 3 | M+ (Motor/Power) |
| 4 | EOS IN |
| 5 | EOS OUT |
| 6 | M- (Motor/Power) |

*EOS equal to end of stroke

| E3 (Encoded) | |
|--------------|---|
| 1 | GND |
| 2 | VCC |
| 3 | M+ (Motor/Power) |
| 4 | Analogue encoded (Hall-A + EOS* IN/OUT) |
| 5 | NC |
| 6 | M- (Motor/Power) |

*EOS equal to end of stroke

| Analogue encoded | EOS |
|------------------|------|
| 2.65V - 3.25V | NONE |
| 2.15V - 2.65V | NONE |
| 1.65V - 2.15V | OUT |
| 1.15V - 1.65V | OUT |
| 0.65V - 1.15V | IN |
| 0.05V - 0.65V | IN |

| E3 (Encoded) F3 (dual Hall encoded) | |
|-------------------------------------|---|
| 1 | GND |
| 2 | VCC |
| 3 | M+ (Motor/Power) |
| 4 | Analogue encoded (Hall-A + EOS* IN/OUT) |
| 5 | Hall B |
| 6 | M- (Motor/Power) |

*EOS equal to end of stroke E1 (Power switch)

| Interval | Hall-A | EOS |
|---------------|--------|------|
| 2.65V - 3.25V | LOW | NONE |
| 2.15V - 2.65V | HIGH | NONE |
| 1.65V - 2.15V | LOW | OUT |
| 1.15V - 1.65V | HIGH | OUT |
| 0.65V - 1.15V | LOW | IN |
| 0.05V - 0.65V | HIGH | IN |

| E1 (Power switch) | |
|-------------------|------------------|
| 1 | NC |
| 2 | NC |
| 3 | M+ (Motor/Power) |
| 4 | NC |
| 5 | NC |
| 6 | M- (Motor/Power) |

| E1 (Power switch) F2 (dual Hall) See next page | |
|--|------------------|
| 1 | GND |
| 2 | VCC |
| 3 | M+ (Motor/Power) |
| 4 | Hall A |
| 5 | Hall B |
| 6 | M- (Motor/Power) |

Feedback specifications

Dual Hall, Encoded (F3) is used only for LINAK A/S control boxes.

Dual Hall, digital (F2) is used for not LINAK A/S control boxes.

Dual Hall, digital (F2) positioning.

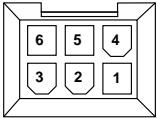
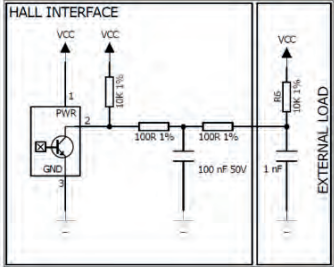
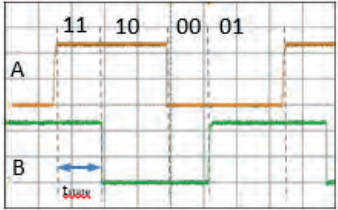
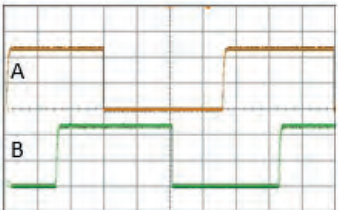
| Item | Specification | Comment | | | | | | | | | | | | |
|-------------------|--|---|-----|-------|-----|-------|----|-------|--------|-------|--------|-------|----|---|
| Pin configuration | <table border="1"> <tr> <td>Pin 1</td> <td>GND</td> </tr> <tr> <td>Pin 2</td> <td>VCC</td> </tr> <tr> <td>Pin 3</td> <td>M+</td> </tr> <tr> <td>Pin 4</td> <td>HALL A</td> </tr> <tr> <td>Pin 5</td> <td>HALL B</td> </tr> <tr> <td>Pin 6</td> <td>M-</td> </tr> </table> | Pin 1 | GND | Pin 2 | VCC | Pin 3 | M+ | Pin 4 | HALL A | Pin 5 | HALL B | Pin 6 | M- | Connector in LA40 housing:  |
| Pin 1 | GND | | | | | | | | | | | | | |
| Pin 2 | VCC | | | | | | | | | | | | | |
| Pin 3 | M+ | | | | | | | | | | | | | |
| Pin 4 | HALL A | | | | | | | | | | | | | |
| Pin 5 | HALL B | | | | | | | | | | | | | |
| Pin 6 | M- | | | | | | | | | | | | | |
| VCC | 4 - 15V | Feedback circuit has to be powered 50 ms before driving, and until actuator has stopped moving | | | | | | | | | | | | |
| Current | Maximum 15 mA @10kΩ and 1nF load. See diagram. |  | | | | | | | | | | | | |
| HALL A/B | <p>TState is minimum 5ms in all states (11,10,00,01)</p> <p>Duty cycle Hall A 30 - 70%</p> <p>Duty cycle Hall B 30 - 70%</p> <p>Low level < GND + 0.5V @10kΩ and 1nF load</p> <p>High level > VCC - 0.5V @10kΩ and 1nF load</p> <p>Driving out, the Hall B signal will go high when Hall A signal is low.</p> <p>Driving in, the Hall A signal will go high when Hall B signal is low.</p> | <p>Driving out:</p>  <p>Driving in:</p>  | | | | | | | | | | | | |
| Resolution | <p>The feedback system gives 16 state shifts per spindle turn.</p> <p>3 mm pitch => 0.1875 mm per shift</p> <p>4 mm pitch => 0.25 mm per shift</p> | <p>On 100 mm stroke you will have the following number of pulses:</p> <p>3 mm pitch => 533 shifts</p> <p>4 mm pitch => 400 shifts</p> | | | | | | | | | | | | |

Feedback specifications

| E1 (power switch) F6 (potentiometer) | |
|--------------------------------------|------------------------|
| 1 | GND |
| 2 | NC |
| 3 | M+ (motor/power) |
| 4 | Potentiometer feedback |
| 5 | VCC |
| 6 | M- (motor/power) |

| Feedback specification | |
|--|-------------------|
| VCC max. | 5 V |
| Resistor | 8 - 12 k Ω |
| Linearity (\pm 2% of *maximum stroke) | \pm 5.8 mm |
| Precision (\pm 5% of *maximum stroke) | \pm 14,5 mm |

| Calculation of maximum stroke length | |
|--------------------------------------|------------|
| Gearing | 4 |
| Spindle pitch | 5 mm / rev |
| Total turns on potentiometer | 14,5 turns |
| *maximum stroke | 280 mm |

| E2 (signal) F6 (potentiometer) | |
|--------------------------------|------------------------|
| 1 | GND (common EOS*) |
| 2 | VCC |
| 3 | M+ (Motor/Power) |
| 4 | Potentiometer feedback |
| 5 | EOS* IN/OUT |
| 6 | M- (Motor/Power) |

* EOS equal to end of stroke

| Feedback specification LINAK A/S system | |
|--|---------------|
| Linearity (\pm 2% of *maximum stroke) | \pm 5.8 mm |
| Precision (\pm 5% of *maximum stroke) | \pm 14,5 mm |

| Calculation of maximum stroke length | |
|--------------------------------------|------------|
| Gearing | 4 |
| Spindle pitch | 5 mm/rev |
| Total turns on potentiometer | 14.5 turns |
| *maximum stroke | 280 mm |

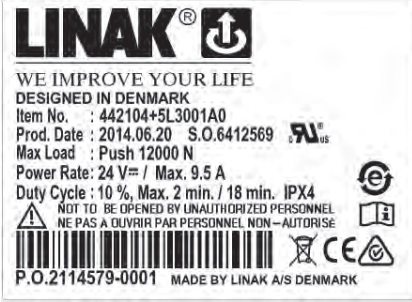

The LA44 is available in powerful 10,000 N and 12,000 N versions, ensuring safe patient handling.

With the LA44 actuator, LINAK offers a product, which with its wide range of safety options, low noise level, and outstanding performance is the right choice for medical applications such as patient lifts, beds, dental chairs etc.

Usage:

- **Electrical spline functionality:** Electrical spline; can be combined with manual lowering. The Electrical-spline switch is mounted inside LA44. It activates on a pulling movement of the slightly moveable back fixture. When using the actuator in a vertical position, the force needed to activate the electric spline is maximum 100 N + the weight of the application. To reengage the spline function, a force of maximum 100 N is needed.
- **Mechanical spline functionality:** When using the actuator in a vertical position, the force needed to activate the mechanical spline is maximum 60 N + the weight of the application. To reengage the spline function, a force of maximum 60 N is needed.
- **Duty cycle:** 10 %, 2 minutes continuous use followed by 18 minutes not in use
- **Usage temperature:** 5 °C to 40 °C
- **Storage temperature:** - 10 °C to + 50 °C
- **Compatibility:** Compatible with LINAK control boxes. Please contact LINAK
- **Approvals:** IEC 60601-1, ANSI/AAMI ES60601-1 and CAN/CSA 22.2 No 60601-1



Recommendations:

- The actuator is not suitable for outdoor applications
- Power supply without current cut-off can cause serious damage to the actuator if a mechanical stop is encountered or the actuator movement is blocked in another way.
- If there is a risk of "pull forces" in the application, the actuator must be equipped with mechanical or electrical spline to avoid damage in pull.
- If the actuator is operated without load (e.g. loose on a table) the electrical spline can activate and the actuator cannot run in an inwards direction. Push the back fixture and the actuator can be operated again.
- Connection bolts must be dimensioned so that they have the necessary strength in order to obtain the minimum safety factor according to the requirements of the authorities.
- The actuator must not be subject to a side load, as this can cause bending. It is also for this reason that the actuator should not be used as a handle, e.g. pulling a patient hoist sideways.
- The actuator must not be subject to off centre loading, as this can damage the actuator.
- The actuator must not be subject to impact, or any form of stress to the casing.
- The actuator must not be subject to overload, as this can reduce the lifetime of the actuator and in the worst case cause damage to the actuator.
- The actuator must not be used in pull applications, as this can cause collapse.
- Only use the actuator within the specified working limits.
- It is recommended that the actuator is serviced according to the relevant national norms for the applications in which the actuator is used.
- Connection bolts and brackets are to be inspected in connection with service, and must be replaced if there are signs of wear.
- The safety function: Electrical Spline, should be checked in connection with service. The function is checked by applying a straight pull, of max. 100 N, to the back fixture. The actuator must not be able to run in an inward direction. Hereafter press the back fixture against the housing and the actuator can run in an inward direction.
- The actuator should be cleaned regularly, in order to maintain a good hygiene.



LA44 actuators for patient hoists are marked with a label to ensure the user is aware that it is not permitted to handle the patient hoist by pulling the actuator or otherwise expose it to side forces.

Self-locking ability.

- LINAK control boxes are designed so that they will short-circuit the motor terminals (poles) of the actuator(s), when the actuator(s) are not running. This solution gives the actuator(s) a higher self-locking ability. If the actuator(s) are not connected to a LINAK control box, the terminals of the motor must be short-circuited to achieve the selflocking ability of the actuator.

Manual lowering:

The following pictures illustrate a) The manual lowering procedure and b) How to fit and remove the plug connection using the "Smart cable lock"



Fig. 1. Manual Lowering

In case of a power failure it is possible to mechanically lower a patient placed in a patient hoist. When turning the manual lowering handle clockwise the actuator can be moved fully inwards.

Fitting the plug/smart cable lock

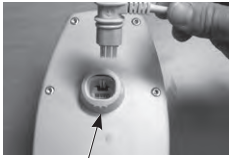

Fig. 1

Step 1:
The three flanges in this position indicate that the "smart cable locking" device is in the unlocked position.



Fig. 2

Step 2:
Position and press the cable plug into the socket.

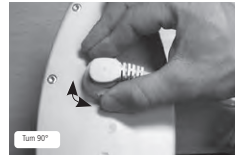



Fig. 3

Step 3:
Hold around the lock flanges and turn the lock either clockwise or anticlockwise. The cable is fully locked when turned 90 °C.



Feedback specifications

Potentiometer

| Item | Specification | Comment | | | | | | | | | | | | | | |
|-------------------|--|--|--|-------|---------|-------|------|-------|------------------|-------|--------------|-------|-------------|-------|------------------|--|
| Description | The actuator can be equipped with a potentiometer for precise positioning. The potentiometer is a variable resistance, the magnitude of which varies linearly with the position of the actuator rod. |  | | | | | | | | | | | | | | |
| Type | ALPS RDC40, 0-10 kOhm $\pm 30\%$, linearity $\pm 1\%$ | | | | | | | | | | | | | | | |
| Input voltage | 3.3 V recommended | | | | | | | | | | | | | | | |
| Pin configuration | LA44 Mini-fit plug cable (potentiometer) <table border="1" data-bbox="266 1203 542 1422"> <thead> <tr> <th colspan="2">Potentiometer</th> </tr> </thead> <tbody> <tr> <td>Pin 1</td> <td>Pot GND</td> </tr> <tr> <td>Pin 2</td> <td>Vbus</td> </tr> <tr> <td>Pin 3</td> <td>M+ (Motor/Power)</td> </tr> <tr> <td>Pin 4</td> <td>Pot Position</td> </tr> <tr> <td>Pin 5</td> <td>Pot + (3V3)</td> </tr> <tr> <td>Pin 6</td> <td>M- (Motor/Power)</td> </tr> </tbody> </table> | Potentiometer | | Pin 1 | Pot GND | Pin 2 | Vbus | Pin 3 | M+ (Motor/Power) | Pin 4 | Pot Position | Pin 5 | Pot + (3V3) | Pin 6 | M- (Motor/Power) |  |
| Potentiometer | | | | | | | | | | | | | | | | |
| Pin 1 | Pot GND | | | | | | | | | | | | | | | |
| Pin 2 | Vbus | | | | | | | | | | | | | | | |
| Pin 3 | M+ (Motor/Power) | | | | | | | | | | | | | | | |
| Pin 4 | Pot Position | | | | | | | | | | | | | | | |
| Pin 5 | Pot + (3V3) | | | | | | | | | | | | | | | |
| Pin 6 | M- (Motor/Power) | | | | | | | | | | | | | | | |
| Combinations | The potentiometer positioning cannot be combined with LA44IC. | | | | | | | | | | | | | | | |

Feedback specifications

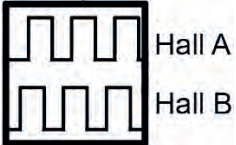
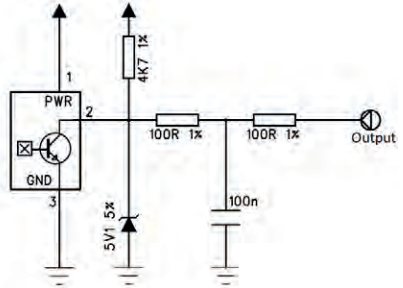
Hall

| Item | Specification | Comment | | | | | | | | | | | | | | |
|-------------------|---|---|------|-------|----------|-------|------|-------|------------------|-------|--------|-------|--------|-------|------------------|---|
| Description | The actuator can be equipped with Dual Hall that gives a relative positioning feedback signal when the actuator moves. |  | | | | | | | | | | | | | | |
| Input voltage | 4-15V | The feedback circuit has to be powered 50 ms before driving and until the actuator has stopped moving | | | | | | | | | | | | | | |
| Current | Maximum 20 mA. See diagram. |  | | | | | | | | | | | | | | |
| Pin configuration | LA44 Mini-Fit plug cable (Hall) with feedback <table border="1" data-bbox="263 790 543 1005"> <thead> <tr> <th></th> <th>Hall</th> </tr> </thead> <tbody> <tr> <td>Pin 1</td> <td>Hall GND</td> </tr> <tr> <td>Pin 2</td> <td>Vbus</td> </tr> <tr> <td>Pin 3</td> <td>M+ (Motor/Power)</td> </tr> <tr> <td>Pin 4</td> <td>Hall A</td> </tr> <tr> <td>Pin 5</td> <td>Hall B</td> </tr> <tr> <td>Pin 6</td> <td>M- (Motor/Power)</td> </tr> </tbody> </table> | | Hall | Pin 1 | Hall GND | Pin 2 | Vbus | Pin 3 | M+ (Motor/Power) | Pin 4 | Hall A | Pin 5 | Hall B | Pin 6 | M- (Motor/Power) | PCBA header top view  |
| | Hall | | | | | | | | | | | | | | | |
| Pin 1 | Hall GND | | | | | | | | | | | | | | | |
| Pin 2 | Vbus | | | | | | | | | | | | | | | |
| Pin 3 | M+ (Motor/Power) | | | | | | | | | | | | | | | |
| Pin 4 | Hall A | | | | | | | | | | | | | | | |
| Pin 5 | Hall B | | | | | | | | | | | | | | | |
| Pin 6 | M- (Motor/Power) | | | | | | | | | | | | | | | |

Unlocking the plug/smart cable lock

Flanges in locked position

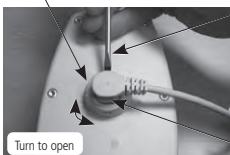

Press here with tool

Fig. 1

No tap on this side

Using a tool, release the lock (must be from the side shown) by pushing the tap (through the small slot in the side of the lock).

At the same time, turn the lock 90 °C in either direction to release the plug connection.

4. Information on specific columns





1. BL1 (MEDLINE® CARELINE® TECHLINE®)

LINAK® 

WE IMPROVE YOUR LIFE

DESIGNED IN DENMARK
Item No. : BL1411A01400A
Prod. Date : 2014.06.20 S.O.6148789
Max Load : Push 2000N IPX6
Power Rate : 24V= / Max. 4.4 A
Duty Cycle : 10%, max. 2 min./18 min.

NOT TO BE OPENED BY UNAUTHORIZED PERSONNEL
NE PAS A OUVRIER PAR PERSONNEL NON-AUTORISE

P.O.2114579-0001 MADE BY LINAK A/S DENMARK

CN 12 0690

The BL1 is a 3-part lifting column designed to be used for example in hospital beds, nursing home beds, treatment chairs, couches and dental chairs.

The lifting column is compact and has a long stroke length. The 3-part guidance enables an overlap between the individual profiles, which ensures a high degree of stability.

The lifting column has an open spindle actuator with a chain drive inside which is practically noiseless.

Usage:

- Duty cycle: 10%, 2 minutes continuous use followed by 18 minutes not in use
- Usage temperature: + 5 °C to + 40 °C
- Storage temperature: Max 50 °C
- Approvals: IEC60601-1, ANSI/AAMI ES60601-1, CAN/CSA-22.2 No 60601-1 IEC 60601-1-6 IEC 60601-1-2

Input/output specifications: dual Hall, digital positioning

Column with Dual Hall (BL141H) are equipped with two hall sensors, A and B and a spindle magnet. In this way you can have pulses from the column when it moves.

The feedback system has a 8P magnet which gives 16 shifts in pulses per spindle turn.



Hall Output:

4 mm spindle = 0,25 mm per pulse and 400 pulses per 100 mm stroke.

9 mm spindle = 0,5625 mm per pulse and 178 pulses per 100 mm stroke.

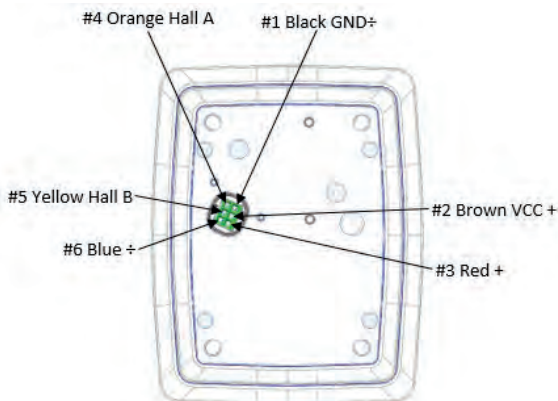

Important:

The motor must always be short-circuited to obtain self-locking in accordance with the rated label value.



Recommendations

- Please follow the important BL1 mounting guidelines.
- Max. storage temperatures: +50 °C.
- BL1 is for use in push applications, cable outlet from smallest profile (top) or biggest profile (bottom). See top and bottom plate dimensions.
- When washing according to IPX6 parameters, it is not allowed to splash water directly onto the plastic frames between the profiles.
- Direct splashing is only permitted on the aluminium profiles. Alternatively, BL1 can be mounted upside down with the largest profile at the top. In this configuration, no IP rating applies.



Warnings

- BL1 is heavy (9.8 kg) To avoid personal injury, DO NOT DROP !
- Do not adjust anything during movement, can cause personal injury !
- LINAK recommend using a safety nut in medical applications !
- A broken chain causes a drop of half the length of actual stroke. Therefore do not overload !
- The BL1 is designed for use in push applications, dynamic "*Pull forces*" can result in damage to the column and cause collapse of the application.
- Do not loosen any screws on the BL1, this can cause collapse of the column !
- LINAK recommends making regular measurement of Class 1 protective ground conductivity in the application to avoid a disconnected grounding cable. Worn out or defect parts must be replaced.

BL1 end plate kit without cable through:

Top plate dimensions:

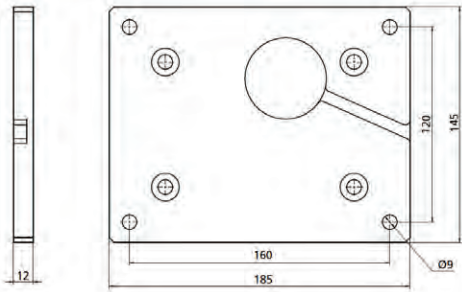

Bottom plate dimensions:

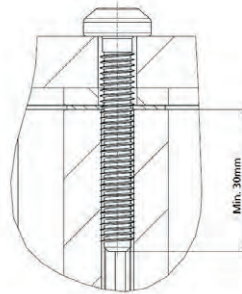
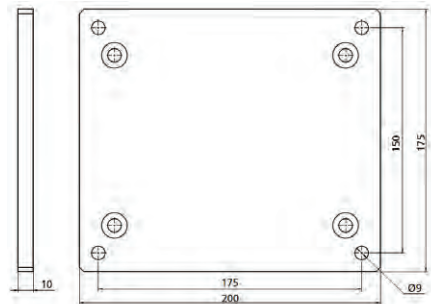

BL1 end plate kit with cable through:

Top plate dimensions:

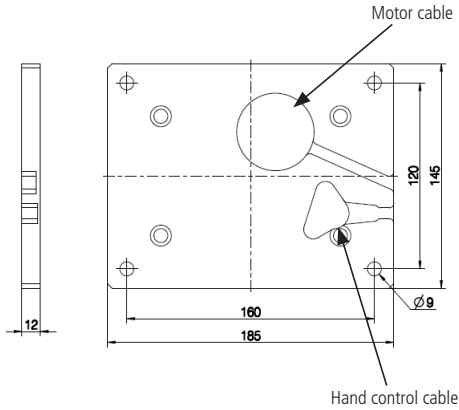

Bottom plate dimensions:

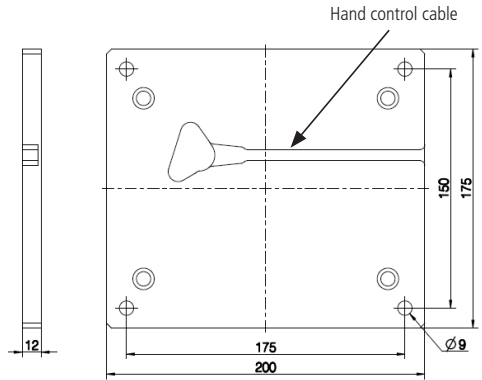

Please notice the thickness of the bottom plate is 12 mm. The thickness of the bottom plate without connections is 10 mm.

Bottom plate dimensions:

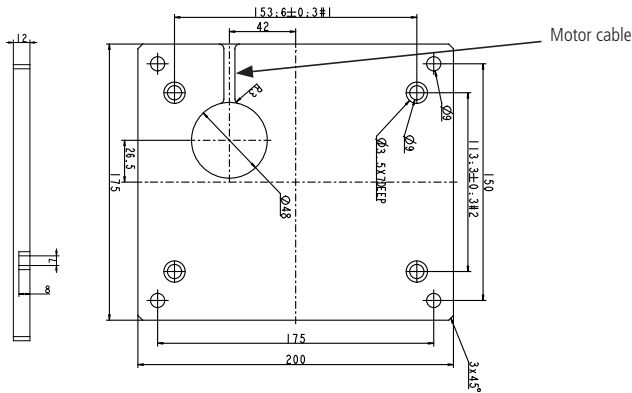

Drawing no.: 0801263-A



BL1 Mounting guidelines:

- BL1 is for use in push applications, and can be mounted in both directions (smallest profile down, or up).
Note: The cable outlet can be positioned at the top (smallest profile). If the option with integrated cable is chosen, the cable outlet can also be positioned at the bottom (biggest profile).
- It is very simple to mount the BL1 in the application using the 4 mounting holes in both endplates.
- Use 4 self-tapping screws, in each end, for mounting to the application. Use EJOT PT type DG Ø8, screw depth must be min. 30 mm in aluminium profile. Screw torque: 15 - 17 Nm.
- If the column has been loosened from the application, it is very important that the self-tapping screws are mounted in the same thread, to ensure the same strength in the thread. Therefore we recommend that the screws are loosened no more than 1 or 2 times.

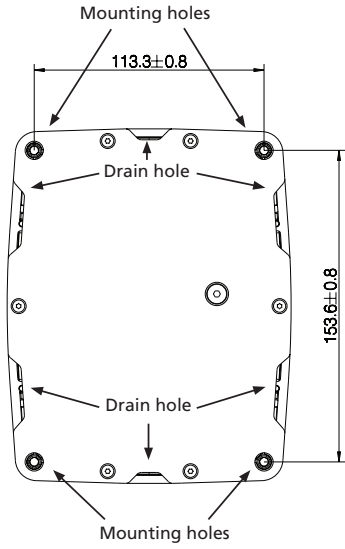
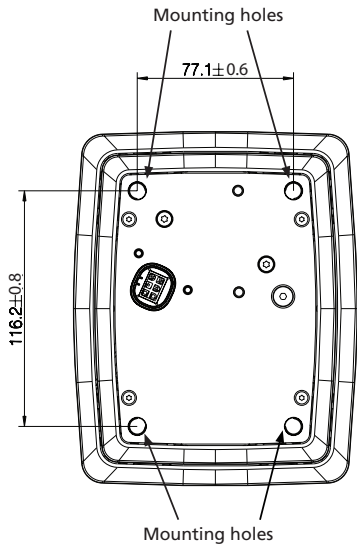

Drawing no.: 0807000-1

Mounting of BL1 with cable through:

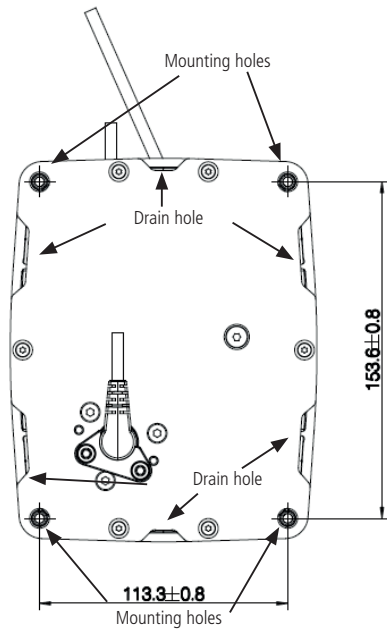
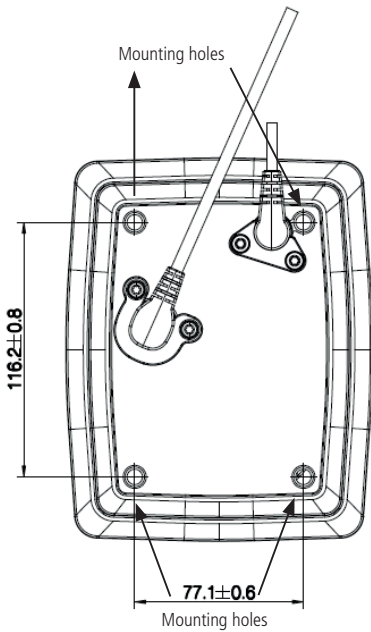

Drawing no.: 0807001-1



Recommendations

- The mounting plate in the application must cover the entire top plate of the BL1 and be strong enough to carry the load.
- Remember to secure the cable mounted in the top of the column to the application, so that it cannot be pulled out of the column. We recommend to use LINAK Cable:
 - Lock kit for BL1 with motor cable: 0808040
 - Lock kit for BL1 with hand control cable through: 0808046
 Use only the screws included in the kit.
- For motor cable mounted at the top, use the long screw with the coarse thread. Screw torque 1.7 Nm.
- For motor cable mounted at the bottom and for cable through, use the short screw with the fine thread. Screw torque 2.7 Nm.
- Electro Static Discharges!

There is no electrical connection through the length of the BL1 column. Therefore, to avoid ESD issues, consider external potential alignment between the top and bottom of the bed frame.

To connect for further earth wiring in the application, use an appropriate $\varnothing 8$ mm cable shoe under one of the 8 mm screws at both the top plate and the bottom plate.
- Remember to mount the blind plugs in the top plate if the motor cable is connected from the bottom plate to ensure the IPX6 protection.

When mounting more than one BL1 you need to consider the fixation:

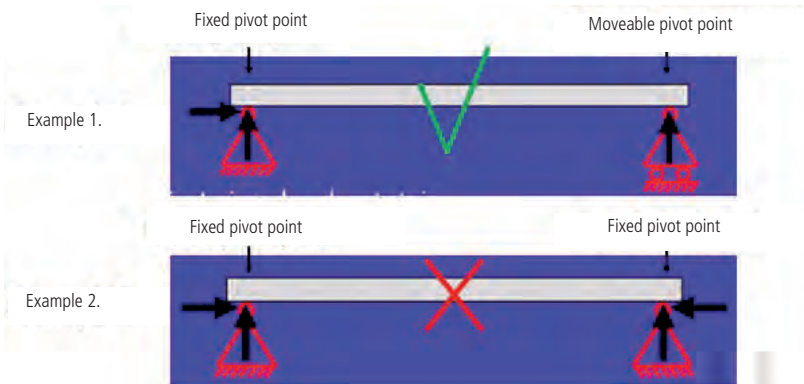

The reason why it is important only to fix one column, is that the columns will not move exactly in parallel – even if you have positioning such as hall.

If more than one column is fixed it can lead to dangerous situations.

If you have a trend/anti-trend function in your application, you need to mount one or more BL1s with a slider.

Having sliders prevents the column from bending as illustrated below.

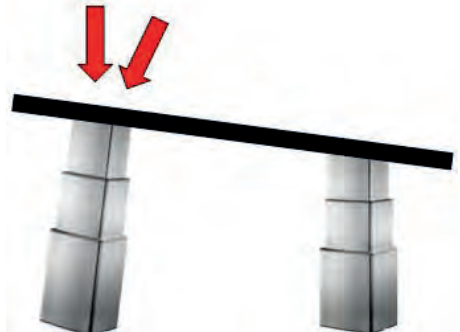
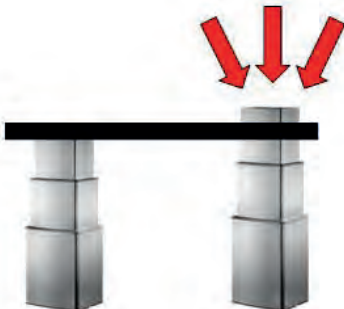

LINAK®
 Designed in Denmark
 DK - 6430 Nordborg
 Type : LC3100400T0000M0320G114-000
 Item No. : J90315
 Prod. Date : 2018.07.03
 Max Load : Push 4000 N IPX4
 Power Rate: 24 V=, Max. 13.8 A
 Duty Cycle : 10%, Max. 2 min. / 18 min.

NOT TO BE OPENED BY UNAUTHORIZED PERSONNEL
 NE PAS OUVRIR PAR DU PERSONNEL NON AUTORISÉ

W/O# - 0001



The LC3 2-stage and 3-stage set the standard for vertical lifting columns to high-end medical applications. This compact lifting column fulfils the market requirements for a solid and stable lifting column.

Usage:

- Duty cycle: 10%, 2 minutes continuous use followed by 18 minutes not in use
- Operation temperature: +5 °C to + 40 °C
- Storage temperature: -40 °C to + 70 °C
- Compatibility: Compatible with LINAK control boxes. Please contact LINAK.
- Relative humidity: 20% to 80% - non-condensing
- Atmospheric pressure: 700 to 1060 hPa
- Meters above sea level: Max. 3000 meters
- Approvals: IEC 60601-1
IEC 60601-1-6
ANSI/AAMI ES60601-1
CAN/CSA-C22.2 No. 60601-1

LC3 mounting guidelines

LC3 is for use in push or pull applications and can be mounted in both directions – largest profile down or largest profile up. LC3 must be specified for specific mounting direction.

Mounting direction according to item number nomenclature.

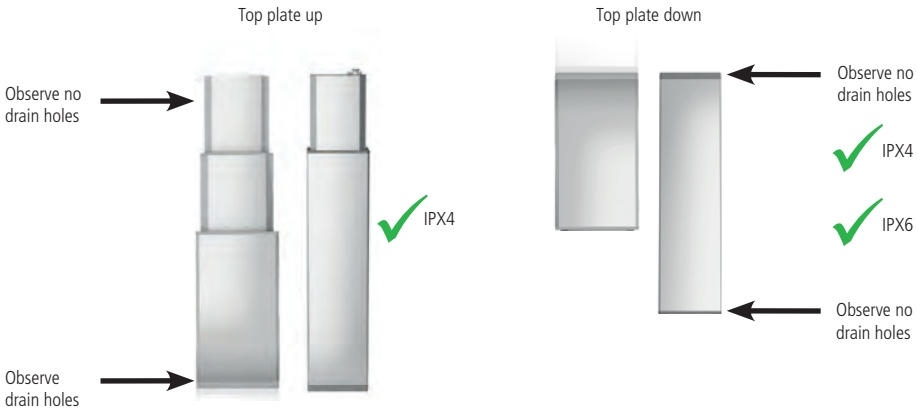

IPX6 is only available when LC3 is mounted with the largest profile up.

IPX6 is only applicable when the LC3 column is fully retracted.

Note: The cable outlet for motor connection can be positioned at the top (smallest profile) or from the side of the column.

LC3 mounting guidelines

If you want to use the column with a high off-center load, we recommend that you install the weight in one of the 3 ways illustrated by the green symbols. It is not recommended to install the weight on the opposite side of the mechanical endstop as illustrated with the red symbol.

This installation can create an uneven movement when the lifting column reaches the endstop position.

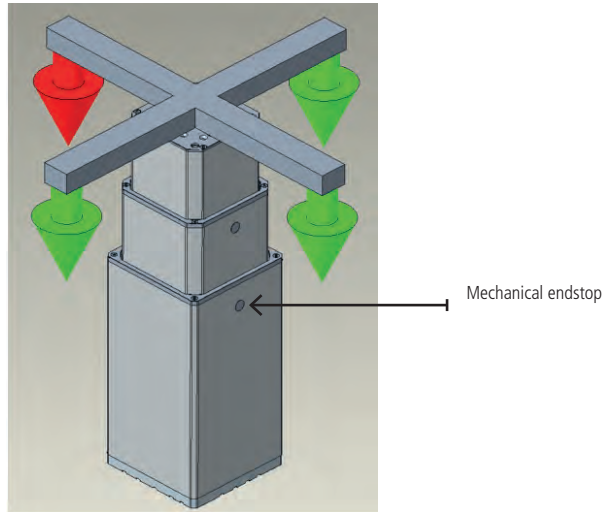

Use 4 pcs. M10 8.8 screws, in each end, for mounting to the application. The screw depth must be min. 20 mm and max. 30 mm in aluminum profile.

Screw torque: 35 Nm.

LC3 3-Stage

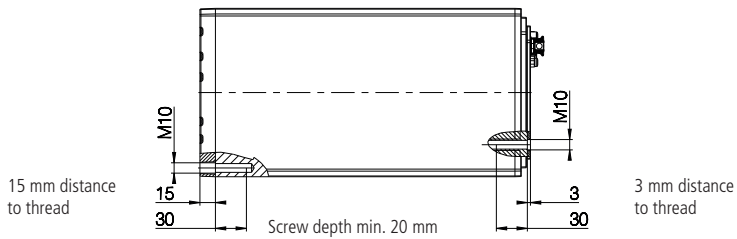

Mounting holes, top

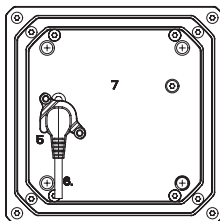

Mounting holes, bottom

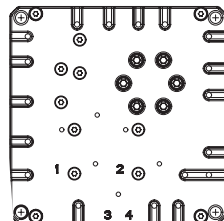

Drawing no.: 1002W9005