

USER MANUAL

BLE Bluetooth Module

WB100N

Version 1.1

Author: Kaysa Lee

Change History

Revision	Date	Author	Change List
Version 1.0	2017/01/06	Kaysa Lee	Preliminary
Version 1.1	2017/03/22	Kaysa Lee	IC use 1802 and update features

** This document contains confidential proprietary information and is property of LTC. The contents of this document should not be disclosed to unauthorized persons without the written consent of LTC.*

CONTENT

PRODUCT FEATURES 3

PRODUCT SPECIFICATIONS..... 3

MAIN CHIPSET 3

FUNCTIONAL SPECIFICATIONS 3

PRODUCT PICTURE..... 5

PIN ASSIGNMENT..... 6

FCC WARING STATEMENT..... 8

Product Features

LiteON BLE Module WB100N 是一款採用 nRF51802 為核心處理器的高性能、低功耗 (Bluetooth Low Energy) 的射頻收發系統模組，擁有超小體積封裝，整體尺寸為 14.3*14.3mm 支持完整的低功耗藍牙 4.0 協議，以及支持藍牙 4.2 Secure Connection，適用各種物聯網應用以及無線應用場景。

用戶 MCU 通過串口 (UART) 跟模組進行連接，可實現和移動智慧設備進行數據的雙向通訊。模組接收到來自使用者 CPU 串口的數據後，將自動轉發給移動智慧設備；移動智慧設備可以通過 APP 發送資料到模組，模組將收到的數據通過串口發送給用戶的 MCU。

模組支援特定的串口 AT 指令配置通信參數 (例如串口串列傳輸速率、藍牙連接間隔等)，並且支援掉電保存。

- 透明傳輸 (橋接方式)，使用方便快捷，無藍牙協定開發經驗者亦可使用
- 使用者介面採用標準的 UART (TTL) 介面，雙向資料收發，操作簡單
- 支援串口 AT 指令，使用者可修改模組的串口串列傳輸速率 (默認 115200bps)、名稱、MAC 地址等基本參數
- 串口硬體使能控制，低功耗控制應用
- 任意串口數據包長度，無限制，更自由
- 藍牙廣播資料可相容 ibeacon 模式
- 通信距離：10~30 米，class II 級
- 通信速率：最高可達 6Kbyte/s
- 供電電壓：1.8~3.6V (3.3V typical)
- 模組尺寸：14.3*14.3mm
- 工作溫度：-40°C~85°C 註：*低電壓模式最低工作溫度為-25°C *

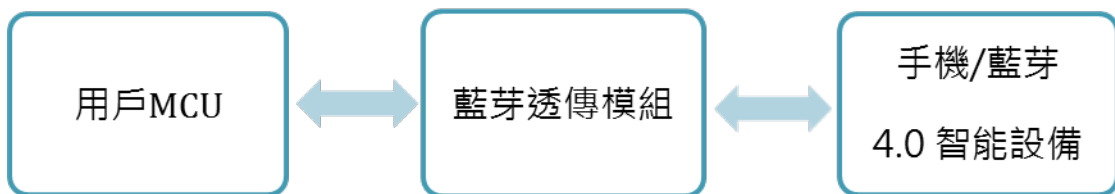

Product Specifications

MAIN CHIPSET

- Nordic nRF51802

FUNCTIONAL SPECIFICATIONS

- 2.4GHz transceiver
- -91 dBm sensitivity in *Bluetooth* low energy mode

- 250 kbps, 1 Mbps, 2 Mbps supported data rates
- TX Power -20 to +4 dBm in 4 dB steps
- TX Power -35 dBm Whisper mode
- 13 mA peak RX, 10.5 mA peak TX (0 dBm)
- 10 mA peak RX, 8 mA peak TX (0 dBm) with DC/DC
- RSSI (1 dB resolution)
- ARM Cortex[™]-M0 32 bit processor
- Serial Wire Debug (SWD)
- S100 series Soft Device ready
- Memory
 - 256 kB embedded flash program memory
 - 16 kB RAM
- On-air compatibility with nRF24L series
- Flexible Power Management
 - Supply voltage range 1.8 V to 3.6 V
 - 7.7 μ s wake-up using 16 MHz RCOSC
 - 0.6 μ A at 3 V OFF mode
 - 1.2 μ A at 3 V in OFF mode + 1 region RAM retention
 - 3 μ A at 3 V ON mode, all blocks IDLE
 - 8/9/10 bit ADC - 8 configurable channels
 - 31 General Purpose I/O Pins
 - One 32 bit and two 16 bit timers with counter mode
 - SPI Master/Slave
 - Low power comparator
 - Temperature sensor
 - Two-wire Master (I2C compatible)
 - UART (CTS/RTS)
 - CPU independent Programmable Peripheral Interconnect (PPI)
 - Quadrature Decoder (QDEC)
 - AES HW encryption
 - Real Time Counter (RTC)

PRODUCT PICTURE

Module:

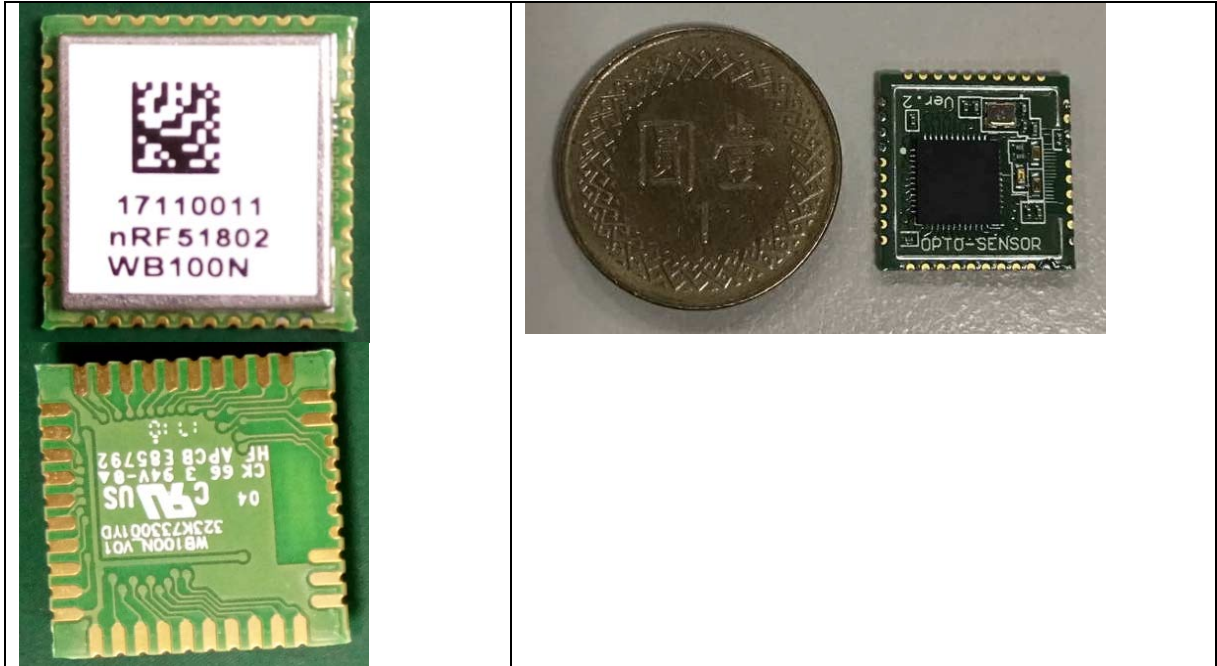

PIN ASSIGNMENT

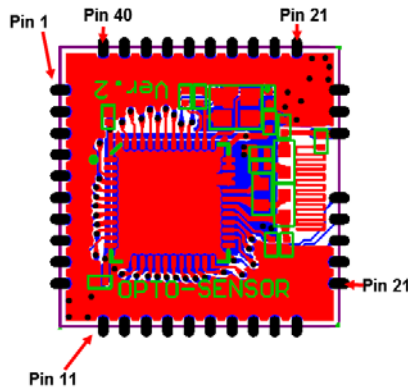
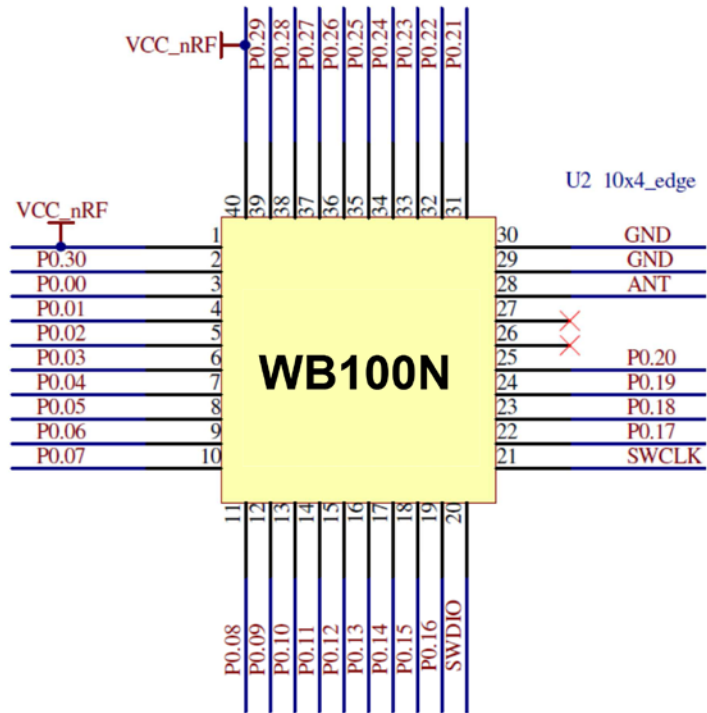

PIN	Name/Function	Remark
1	VDD/Power supply	
2	General purpose I/O pin	P0.30
3	General purpose I/O pin	P0.00
4	General purpose I/O pin	P0.01
5	General purpose I/O pin	P0.02
6	General purpose I/O pin	P0.03
7	General purpose I/O pin	P0.04
8	General purpose I/O pin	P0.05
9	General purpose I/O pin	P0.06
10	General purpose I/O pin	P0.07
11	General purpose I/O pin	P0.08
12	General purpose I/O pin	P0.09
13	General purpose I/O pin	P0.10

14	General purpose I/O pin	P0.11
15	General purpose I/O pin	P0.12
16	General purpose I/O pin	P0.13
17	General purpose I/O pin	P0.14
18	General purpose I/O pin	P0.15
19	General purpose I/O pin	P0.16
20	SWDIO nRESET/System reset (active low). Also hardware debug and flash programming I/O.	
21	SWDCLK/Hardware debug and flash programming I/O.	
22	General purpose I/O pin	P0.17
23	General purpose I/O pin	P0.18
24	General purpose I/O pin	P0.19
25	General purpose I/O pin	P0.20
26	NC	
27	NC	
28	ANT/Differential antenna connection (TX and RX)	
29	GND/Ground (0 V)	
30	GND/Ground (0 V)	
31	General purpose I/O pin	P0.21
32	General purpose I/O pin	P0.22
33	General purpose I/O pin	P0.23
34	General purpose I/O pin	P0.24
35	General purpose I/O pin	P0.25
36	General purpose I/O pin	P0.26
37	General purpose I/O pin	P0.27
38	General purpose I/O pin	P0.28
39	General purpose I/O pin	P0.29
40	VDD/Power supply	

FCC WARNING STATEMENT**FEDERAL COMMUNICATIONS COMMISSION INTERFERENCE STATEMENT**

This equipment has been tested and found to comply with the limits for a Class B digital device, pursuant to Part 15 of the FCC Rules. These limits are designed to provide reasonable protection against harmful interference in a residential installation. This equipment generates, uses and can radiate radio frequency energy and, if not installed and used in accordance with the instructions, may cause harmful interference to radio communications. However, there is no guarantee that interference will not occur in a particular installation. If this equipment does cause harmful interference to radio or television reception, which can be determined by turning the equipment off and on, the user is encouraged to try to correct the interference by one or more of the following measures:

- Reorient or relocate the receiving antenna.
- Increase the separation between the equipment and receiver.
- Connect the equipment into an outlet on a circuit different from that to which the receiver is connected.
- Consult the dealer or an experienced radio/TV technician for help.

CAUTION:

Any changes or modifications not expressly approved by the party responsible for compliance could void the user's authority to operate the equipment.

This device complies with Part 15 of the FCC Rules. Operation is subject to the following two conditions:

- (1) This device may not cause harmful interference and
- (2) This device must accept any interference received, including interference that may cause undesired operation.

FCC Radiation Exposure Statement:

This equipment complies with FCC radiation exposure limits set forth for an uncontrolled environment.

This equipment should be installed and operated with minimum distance 20cm between the radiator & your body

This device and its antenna(s) must not be co-located or operating in conjunction with any other antenna or transmitter.

IMPORTANT NOTE:**The module is limited to OEM installation ONLY**

1. We hereby acknowledge our responsibility to provide guidance to the host manufacturer in the event that they require assistance for ensuring compliance with the Part 15 Subpart B requirements.

2. The host manufacturer is responsible for additional testing to verify compliance as a composite system. When testing the host device for compliance with the Part 15 Subpart B requirements, the host manufacturer is required to show compliance with the Part 15 Subpart B while the transmitter module(s) are installed and operating. The modules should be transmitting and the evaluation should confirm that the module's intentional emissions are compliant (i.e. fundamental and out of band emissions) with the Radio essential requirements. The host manufacturer must verify that there are no additional unintentional emissions other than what is permitted in the Part 15 Subpart B or emissions are complaint with the Radio aspects.

This module is intended for OEM integrator. The OEM integrator is still responsible for

1. ensuring that the end-user has no manual instructions to remove or install module
2. the FCC compliance requirement of the end product, which integrates this module.
3. Appropriate measurements(e.g. 15 B compliance) and if applicable additional equipment authorizations (e.g. Verification, Doc) of the host device to be addressed by the integrator/manufacturer.
4. The separate approval is required for all other operating configurations, including portable configurations with respect to Part 2.1093 and different antenna configurations
5. 20cm minimum distance has to be able to be maintained between the antenna and the users for the host this module is integrated into. Under such configuration, the FCC radiation exposure limits set forth for an population/uncontrolled environment can be satisfied.
6. Any changes or modifications not expressly approved by the manufacturer could void the user's authority to operate this equipment.

The user manual of the end product should include

In the users manual of the end product, the end user has to be informed to keep at least 20cm separation with the antenna while this end product is installed and operated. The end user has to be informed that the FCC radio-frequency exposure guidelines for an uncontrolled environment can be satisfied. The end user has to also be informed that any changes or modifications not expressly approved by the manufacturer could void the user's authority to operate this equipment. If the size of the end product is smaller than the palm of the hand, then additional FCC part 15.19 statement is required to be available in the users manual: This device complies with Part 15 of FCC rules. Operation is subject to the following two conditions: (1) this device may not cause harmful interference and (2) this device must accept any interference received, including interference that may cause undesired operation.

LABEL OF THE END PRODUCT:

The final end product must be labeled in a visible area with the following " Contains TX FCC ID: PPQ-WB100N ". If the size of the end product is larger than the palm of the hand, then the following FCC part 15.19 statement has to also be available on the label: This device complies with Part 15 of FCC rules. Operation is subject to the following two conditions: (1) this device may not cause harmful interference and (2) this device must accept any interference received, including interference that may cause undesired operation.