

# PRODUCT SPECIFICATION

Wi-Fi (11a/b/g/n 2Tx2R)+BT (V4.1LE) USB Combo Module

**WCBN4515R**

**MediaTek MT7632TU**

Version 1.0

## Change History

Revision	Date	Author	Change List
Version 1.0	2016/05/16	Ben J Chen	Preliminary

*\* This document contains confidential proprietary information and is property of LTC. The contents of this document should not be disclosed to unauthorized persons without the written consent of LTC.*

# PRODUCT SPECIFICATION

Wi-Fi (11a/b/g/n 2Tx2R)+BT (V4.1LE) USB Combo Module

## WCBN4515R

## MediaTek MT7662TU

Version 1.0

**Networking B.U.**

**Lite-on Technology Corporation 4F,**

**No. 90, Building C, Chien 1 Rd.,**

**Chung Ho, New Taipei City 235, Taiwan, R.O.C.**



**Customer Approval:** \_\_\_\_\_ (Signature)

\_\_\_\_\_ (Title)

\_\_\_\_\_ (Company)

\_\_\_\_\_ (Date)

(Please Sign Back by FAX. For Confirming the Spec Only, not an Official Agreement for OEM/ODM Business)

## CONTENT

<b>PRODUCT FEATURES .....</b>	<b>4</b>
BT FEATURE .....	4
WI-FI FEATURE.....	4
COMMON FEATURE .....	4
<b>PRODUCT SPECIFICATIONS.....</b>	<b>5</b>
MAIN CHIPSET .....	5
FUNCTIONAL SPECIFICATIONS.....	5
<b>RECOMMENDED OPERATION CONDITIONS.....</b>	<b>8</b>
<b>DC CHARACTERISTICS.....</b>	<b>8</b>
<b>RESET TIMING SPEC.....</b>	<b>8</b>
<b>PIN ASSIGMENT.....</b>	<b>9</b>
<b>USB CONNECTOR SPEC.....</b>	<b>9</b>
<b>MECHANICAL .....</b>	<b>10</b>
<b>EEPROM INFORMATION .....</b>	<b>11</b>
BT.....	11
WI-FI .....	11
<b>ENVIRONMENTAL .....</b>	<b>11</b>
OPERATING .....	11
STORAGE.....	11
<b>PACKING DRAWING .....</b>	<b>12</b>

## PRODUCT FEATURES

### BT FEATURE:

- Bluetooth V4.1 LE system  
Backwards compatible with BT version of 1.1, 1.2, 2.0, 2.1 and 3.0+HS
- Bluetooth Class 1 transmission power
- Best-in-class BT/Wi-Fi coexistence performance
- Support for Simple Pairing (SP) and Enhanced Inquiry Response (EIR) function
- Support for SCATTERNET and up to piconets simultaneously with background inquiry/page scan
- Support wide-band speech and hardware accelerated SBC codec for A2DP streaming
- Support Wake On Bluetooth

### WI-FI FEATURE:

- Operate at ISM frequency Band (2.4/5GHz)
- IEEE Standards Support, 802.11a, 802.11b, 802.11g, and 802.11n
- Support for both 20 MHz and 40 MHz channel width
- Enterprise level security supporting: WPS2.0, WAPI, WPA, WPA2
- Support 2 transmission and 2 receiving, transmission rate can up to 300Mbps (Physical Rate) in downstream and upstream
- QoS support of WFA WMM, WMMPS
- Support for Wi-Fi Direct
- Support Wake On WLAN

### COMMON FEATURE:

- MT7632TU is a single chip integrated IEEE 802.11 a/b/g/n and Bluetooth 4.1LE with a single USB interface
- PA, LNA, and T/R switch integration for Wi-Fi and Bluetooth
- Best-in-class active and idle power consumption performance
- Fully compliance with USB v2.0 specification
- Support OS: Linux based
- RoHS compliance
- Low Halogen compliance

## PRODUCT SPECIFICATIONS

### MAIN CHIPSET

MediaTek MT7632TU

### FUNCTIONAL SPECIFICATIONS

BT Function	
<b>Standard</b>	Bluetooth V4.1LE
<b>Bus Interface</b>	USB2.0
<b>Data Rate</b>	1 Mbps, 2Mbps and Up to 3Mbps
<b>Modulation Scheme</b>	GFSK, $\pi/4$ -DQPSK and 8-DPSK
<b>Frequency Range</b>	2.402~2.480 GHz
<b>Transmit Output Power</b>	+4 ≤ Output Power ≤ +10dBm; Class 1 Device
<b>Receiver Sensitivity</b>	< 0.1% BER at -80dBm
Wi-Fi Function	
<b>Standard</b>	IEEE802.11a; IEEE802.11b; IEEE 802.11g; IEEE 802.11n
<b>Bus Interface</b>	USB2.0
<b>Data Rate</b>	<p><b>802.11a:</b> 54, 48, 36, 24, 18, 12, 9, 6 Mbps</p> <p><b>802.11b:</b> 11, 5.5, 2, 1 Mbps</p> <p><b>802.11g:</b> 54, 48, 36, 24, 18, 12, 9, 6 Mbps</p> <p><b>802.11n:</b> MCS 0 to 15 for HT20MHz MCS 0 to 15 for HT40MHz</p>
<b>Media Access Control</b>	CSMA/CA with ACK
<b>Modulation Technique</b>	<p><b>802.11a:</b> 64QAM, 16QAM, QPSK, BPSK</p> <p><b>802.11b:</b> CCK, DQPSK, DBPSK</p> <p><b>802.11g:</b> 64QAM, 16QAM, QPSK, BPSK</p> <p><b>802.11n:</b> 64QAM, 16QAM, QPSK, BPSK</p>
<b>Network Architecture</b>	Ad-hoc mode (Peer-to-Peer) Infrastructure mode
<b>Operation Channel</b>	<p><b>2.4GHz</b> 11: (Ch. 1-11) – United States 13: (Ch. 1-13) – Europe 14: (Ch. 1-14) – Japan</p> <p><b>5GHz</b></p>

21: USA  
 19: EU  
 8: Japan

<b>Frequency Range</b>	<b>802.11bgn</b> 2.400 ~ 2.4835 GHz <b>802.11a</b> 5.15 ~ 5.85 GHz
<b>Transmit Output Power – 2x2 (Tolerance: ±1.5dBm)</b>	<b>802.11a:</b> 13 dBm@6-54Mbps <b>802.11b:</b> 15 dBm@1-11Mbps <b>802.11g:</b> 14 dBm@6-54Mbps <b>802.11n(2.4G):</b> <b>20MHz:</b> 14 dBm@MCS0-7 <b>40MHz:</b> 12 dBm@MCS0-7 <b>802.11n(5G):</b> <b>20MHz:</b> 13 dBm@MCS0-7 <b>40MHz:</b> 11 dBm@MCS0-7
<b>Receiver Sensitivity</b>	<b>802.11a:</b> -86 dBm@6Mbps -70 dBm@54Mbps <b>802.11b:</b> -88 dBm@1Mbps -82 dBm@11Mbps <b>802.11g:</b> -86 dBm@6Mbps -71 dBm@54Mbps <b>802.11n:</b> <b>2.4/5G</b> <b>20MHz</b> -86 dBm@MCS0 -70 dBm@MCS7 -68 dBm@MCS15 <b>40MHz</b> -83 dBm@MCS0 -67 dBm@MCS7 -65 dBm@MCS15
<b>Security</b>	WPS, WPA, WPA2, WEP 64bit & 128bit, IEEE 802.1X, IEEE 802.11i

**Common Function**

**Operating Voltage** 5 V ±5% I/O supply voltage

	Mode	Average		Peak	
		2.4G	5G	2.4G	5G
<b>Power Consumption</b>	<b>TX</b>	560mA	690mA	850mA	920mA
	<b>RX</b>	290mA	325mA		
	<b>Idle</b>	30mA			
	<b>WiFi+B T@wake up mode</b>	4.5mA			



**RECOMMENDED OPERATION CONDITIONS**

For Module

Symbol	Rating	Min	Typ	Max	Units
VCC	5V Supply Voltage	4.75	5	5.25	V

For IC

Symbol	Rating	Min	Typ	Max	Units
VDD33	3.3V Supply Voltage	2.97	3.3	3.63	V
VDD12	1.2V Supply Voltage	1.14	1.2	1.26	V
VDD15	1.5V Supply Voltage	1.425	1.5	1.575	V

**DC CHARACTERISTICS**

Symbol	Parameter	Min	Typ	Max	Units
V <sub>IL</sub>	Input Low Voltage	-0.28	-	0.6	V
V <sub>IH</sub>	Input High Voltage	2.0	-	3.63	V
V <sub>OL</sub>	Output Low Voltage	-0.28	-	0.4	V
V <sub>OH</sub>	Output High Voltage	2.4	-	3.63	V

**RESET TIMING SPEC**

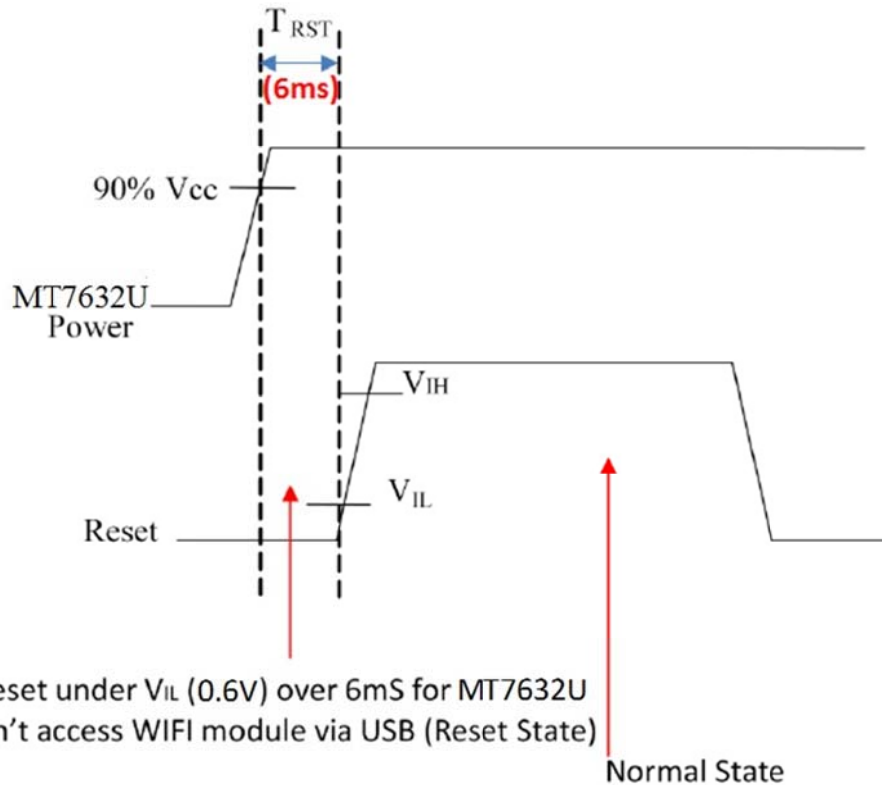



## PIN ASSIGNMENT

Pin.	Pin Define	Description	Status
1	+5VCC	5V source	YES
2	WoBT	Wake up system via BT, low active	YES
3	WoWLAN	Wake up system via wifi, low active	YES
4	RESET#	System reset MT7632U, low active	YES
5	GND	Ground	YES
6	USB D+	USB Data+	YES
7	USB D-	USB Data-	YES
8	GND	Ground	YES



## USB CONNECTOR SPEC

版本 REV.	日期 DATE	ECN NO.	变更内容 DESCRIPTION	制图 DRAWN
B				

No. of Contacts	DIMENSIONS					
	A	B	C	D	E	F
2	1.25	7.45	3.81	2.83	2.43	3.50
3	2.50	8.70	5.06	4.08	3.68	3.50
4	3.75	9.95	6.31	5.33	4.93	3.50
5	5.00	11.20	7.56	6.58	6.18	3.50
6	6.25	12.45	8.81	7.83	7.43	3.50
7	7.50	13.70	10.06	9.08	8.68	3.50
8	8.75	14.95	11.31	10.33	9.93	3.50
9	10.00	16.20	12.56	11.58	11.18	3.50
10	11.25	17.45	13.81	12.83	12.43	3.50
11	12.50	18.70	15.06	14.08	13.68	5.00
12	13.75	19.95	16.31	15.33	14.93	5.00
13	15.00	21.20	17.56	16.58	16.18	5.00
14	16.25	22.45	18.81	17.83	17.43	5.00
15	17.50	23.70	20.06	19.08	18.68	5.00
20	23.75	29.95	26.31	25.33	24.93	5.00
25	30.00	36.20	32.56	31.58	31.18	6.00
30	36.25	42.45	38.81	37.83	37.43	6.00

Ordering Code: S1315 - XX R V X - S03- K

① Series NO.  
 ② Circuits number  
 ③ R: Right Angle  
 ④ V: Prefix "V" means lead free plating  
 ⑤ Plating Code: 

Definition	Code
Gold plated:	A
Flash:	B 15μm F
10μm:	C 10μm J
Duplex plating:	
Flash:	K 15μm IP
10μm:	N 10μm U

⑥ Packing:  
 Null: Tube  
 K: Reel  
 C: FILM+REEL

NOTES: (UNLESS OTHERWISE SPECIFIED)  
 1. Temperature range: -25°C~+85°C  
 2. Voltage rating: 150V, AC, DC  
 3. Current rating: 1A  
 4. Contact resistance: 20mΩ Max.  
 5. Insulation resistance: 500MΩ Min.  
 6. Withstand voltage: 500V, AC/minute

Material:  
 Housing: High Temperature Thermoplastic UL 94V-0  
 Contact: Phosphor Bronze, Gold plated  
 Clip: Brass, Gold plated

Recommended PCB Layout (PCB tolerance ±0.05)

GENERAL TOLERANCE

UNIT	SCALE	1:1
X±0.30	X'±2'	MM
.X±0.25	.X'±1'	MM
.XX±0.20	.XX'±0.5'	MM
.XXX±0.15	.XXX'±0.5'	MM

2009.09.24

苏州新亚电通有限公司

SHUO KINYA ELECTRONIC COMMUNICATION CO., LTD.

**MECHANICAL**

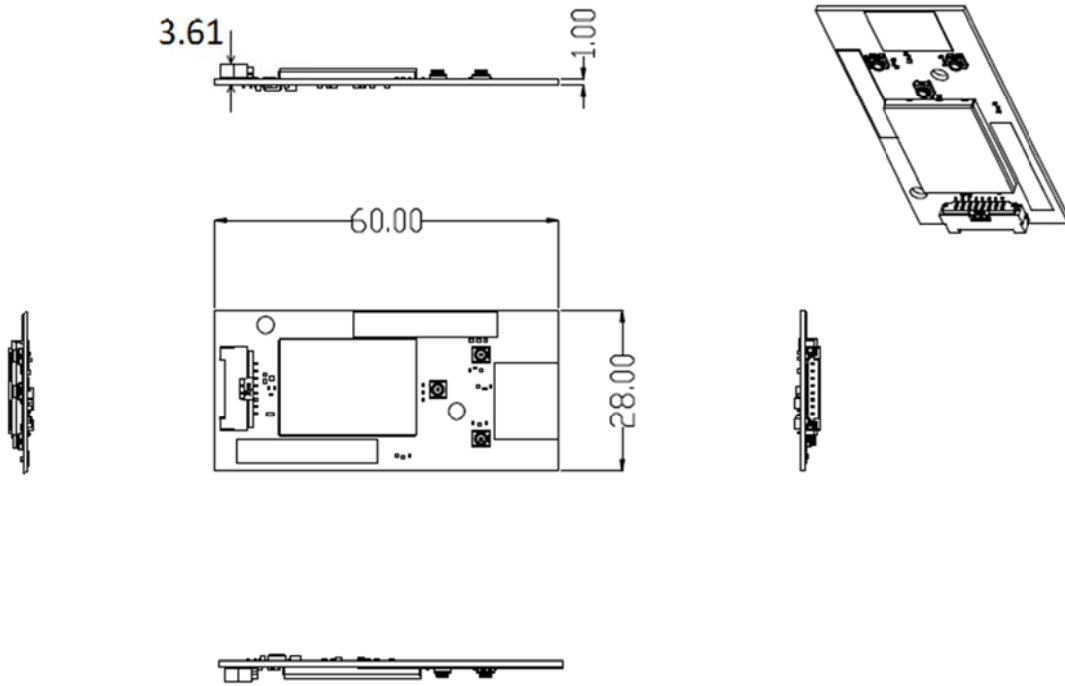

**Unit:mm**

**Tolerance:**

DIM	DEG				ANGLE
	A	B	C	D	
0-5	±0.06	±0.05	±0.10		0°-30° ±0.1°
5-10	±0.05	±0.10	±0.15		31°-60° ±0.3°
10-50	±0.10	±0.15	±0.20		61°-90° ±0.5°
50-100	±0.15	±0.20	±0.25		
100-	±0.15%	±0.20%	±0.25%		

**EEPROM INFORMATION****BT**

<b>Vendor ID</b>	0x0E8D
<b>Product ID</b>	0x76A1

**Wi-Fi**

<b>Reg Domain</b>	World Wide <b>2.4G/5G</b> Read from registry; Control by driver
	Offset 0x38 for 5G: 0xFF Offset 0x39 for 2.4G: 0xFF
<b>Vendor ID</b>	0x0E8D
<b>Device ID</b>	0x76A1

**ENVIRONMENTAL****OPERATING**

Operating Temperature: 0 to 70 °C (32 to 158 °F)

Relative Humidity: 5-90% (non-condensing)

**STORAGE**

Temperature: -40 to 80 °C (-40 to 176 °F)

Relative Humidity: 5-95% (non-condensing)

**PACKING DRAWING**

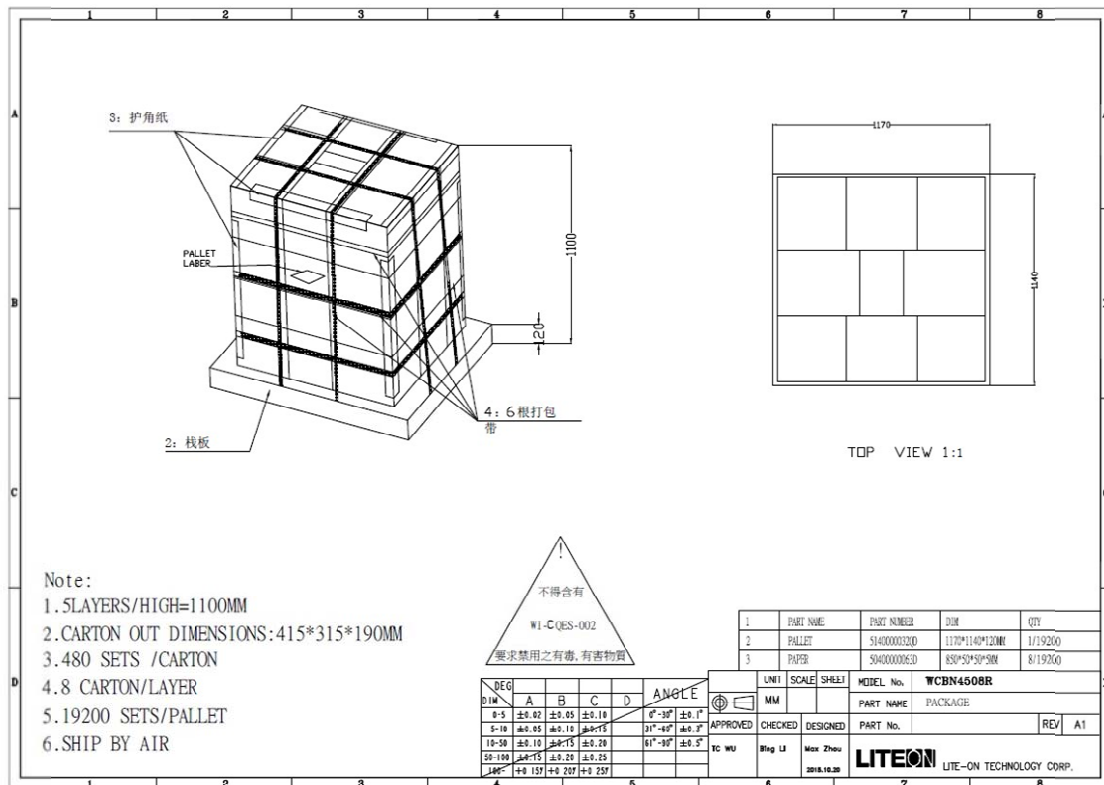
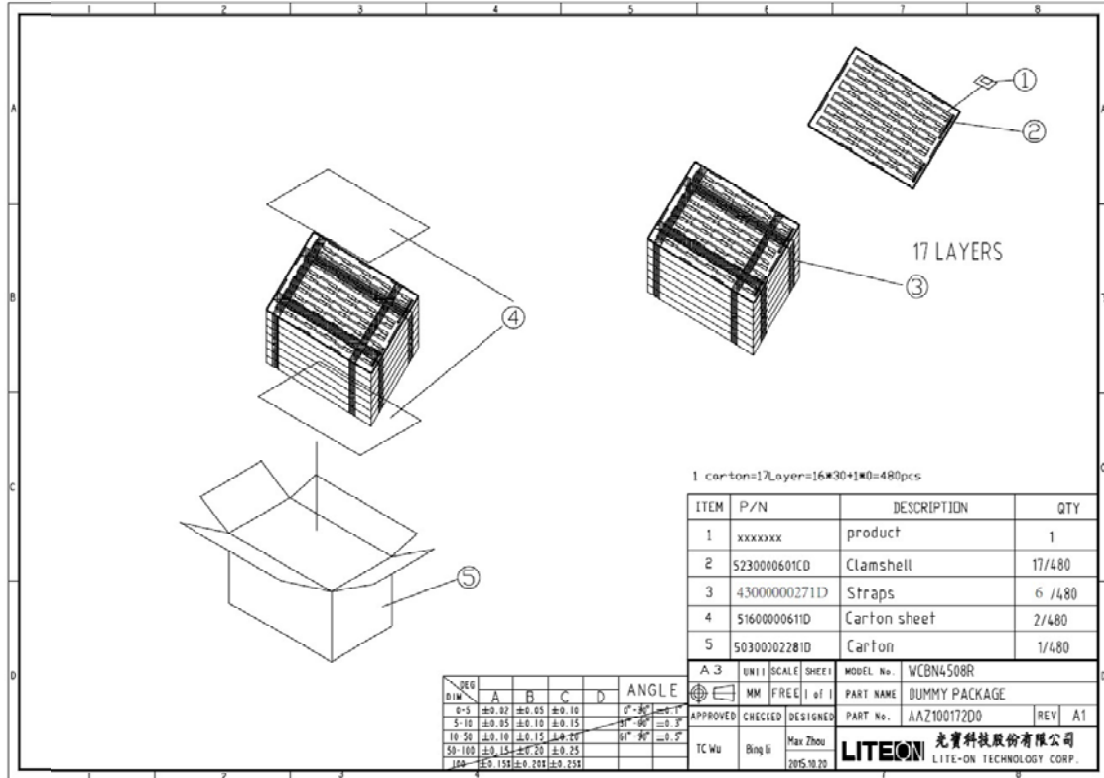

**FCC Statement:**

## Federal Communication Commission Interference Statement

This equipment has been tested and found to comply with the limits for a Class B digital device, pursuant to Part 15 of the FCC Rules. These limits are designed to provide reasonable protection against harmful interference in a residential installation. This equipment generates, uses and can radiate radio frequency energy and, if not installed and used in accordance with the instructions, may cause harmful interference to radio communications. However, there is no guarantee that interference will not occur in a particular installation. If this equipment does cause harmful interference to radio or television reception, which can be determined by turning the equipment off and on, the user is encouraged to try to correct the interference by one of the following measures:

- Reorient or relocate the receiving antenna.
- Increase the separation between the equipment and receiver.
- Connect the equipment into an outlet on a circuit different from that to which the receiver is connected.
- Consult the dealer or an experienced radio/TV technician for help.

FCC Caution: Any changes or modifications not expressly approved by the party responsible for compliance could void the user's authority to operate this equipment.

This device complies with Part 15 of the FCC Rules. Operation is subject to the following two conditions: (1) This device may not cause harmful interference, and (2) this device must accept any interference received, including interference that may cause undesired operation.

For product available in the USA/Canada market, only channel 1~11 can be operated. Selection of other channels is not possible.

This device and its antenna(s) must not be co-located with any other transmitters except in accordance with FCC multi-transmitter product procedures.

**IMPORTANT NOTE:**

## FCC Radiation Exposure Statement:

This equipment complies with FCC radiation exposure limits set forth for an uncontrolled environment. This equipment should be installed and operated with minimum distance 20 cm between the radiator & your body.

**IMPORTANT NOTE:**

This module is intended for OEM integrator. The OEM integrator is responsible for the

compliance to all the rules that apply to the product into which this certified RF module is integrated.

Additional testing and certification may be necessary when multiple modules are used.

20 cm minimum distance has to be able to be maintained between the antenna and the users for the host this module is integrated into. Under such configuration, the FCC radiation exposure limits set forth for an population/uncontrolled environment can be satisfied.

Any changes or modifications not expressly approved by the manufacturer could void the user's authority to operate this equipment.

#### USERS MANUAL OF THE END PRODUCT:

In the users manual of the end product, the end user has to be informed to keep at least 20 cm separation with the antenna while this end product is installed and operated. The end user has to be informed that the FCC radio-frequency exposure guidelines for an uncontrolled environment can be satisfied. The end user has to also be informed that any changes or modifications not expressly approved by the manufacturer could void the user's authority to operate this equipment. If the size of the end product is smaller than 8x10cm, then additional FCC part 15.19 statement is required to be available in the users manual: This device complies with Part 15 of FCC rules. Operation is subject to the following two conditions: (1) this device may not cause harmful interference and (2) this device must accept any interference received, including interference that may cause undesired operation.

#### LABEL OF THE END PRODUCT:

The final end product must be labeled in a visible area with the following " Contains TX FCC ID: PPQ-WCBN4515R ". If the size of the end product is larger than 8x10cm, then the following FCC part 15.19 statement has to also be available on the label: This device complies with Part 15 of FCC rules. Operation is subject to the following two conditions: (1) this device may not cause harmful interference and (2) this device must accept any interference received, including interference that may cause undesired operation.

## **OEM Integrator Checklist**

The party below will implement the LITE-ON Module in host systems in accordance with the instructions specified in this document and the documents referenced herein.

1. The OEM integrator will ensure the Module is integrated in a host systems using only the approved antenna model(s) described in this document.

BT : LITE-ON / WCBN4515R / PCB Antenna / Gain: -0.80 dBi

BT : MAG.LAYERS / MSA-3310-25GC4-A1 / PIFA Antenna / Gain: 2.28 dBi

2.4G\_2 : LITE-ON / WCBN4515R / PCB Antenna / Gain: 3.41 dBi

2.4G\_2 : LITE-ON / WCBN4515R / PCB Antenna / Gain: 2.18 dBi

5G\_2 : LITE-ON / WCBN4515R / PCB Antenna / Gain: 1.88 dBi

5G\_2 : LITE-ON / WCBN4515R / PCB Antenna / Gain: -0.17 dBi

2. The OEM integrator will ensure the antenna placement inside the host system will maintain the required spacing to end user for RF Exposure compliance, as specified in this document.

3. If other radios are integrated inside the host with the LITE-ON Module, the OEM integrator will contact its test lab, TCB or LITE-ON to determine if additional FCC compliance evaluation is required to meet FCC collocation rules.

4. The OEM integrator will ensure end user documentation will contain the specified regulatory wording and ensure the host system and the Module itself are labeled as specified in this document.

5. The OEM integrator will ensure the Module is programmed in the factory with compliant transmit power not exceeding the levels specified in this document.

LITE-ON requests that the OEM integrator acknowledge its receipt of this document and the above instructions. You may contact LITE-ON with any questions concerning this document or the responsibilities of the OEM integrator.

**IC Statement:**

This device complies with Industry Canada license-exempt RSS standard(s). Operation is subject to the following two conditions: (1) this device may not cause interference, and (2) this device must accept any interference, including interference that may cause undesired operation of the device.

Le présent appareil est conforme aux CNR d'Industrie Canada applicables aux appareils radio exempts de licence. L'exploitation est autorisée aux deux conditions suivantes : (1) l'appareil ne doit pas produire de brouillage, et (2) l'utilisateur de l'appareil doit accepter tout brouillage radioélectrique subi, même si le brouillage est susceptible d'en compromettre le fonctionnement.

For product available in the USA/Canada market, only channel 1~11 can be operated.

Selection of other channels is not possible.

Pour les produits disponibles aux États-Unis / Canada du marché, seul le canal 1 à 11 peuvent être exploités. Sélection d'autres canaux n'est pas possible.

This device and its antenna(s) must not be co-located with any other transmitters except in accordance with IC multi-transmitter product procedures.

Referring to the multi-transmitter policy, multiple-transmitter(s) and module(s) can be operated simultaneously without reassessment permissive change.

Cet appareil et son antenne (s) ne doit pas être co-localisés ou fonctionnement en association avec une autre antenne ou transmetteur.

The device for operation in the band 5150–5250 MHz is only for indoor use to reduce the potential for harmful interference to co-channel mobile satellite systems.

les dispositifs fonctionnant dans la bande 5150-5250 MHz sont réservés uniquement pour une utilisation à l'intérieur afin de réduire les risques de brouillage préjudiciable aux systèmes de satellites mobiles utilisant les mêmes canaux.

The maximum antenna gain permitted for devices in the band 5725-5850 MHz shall be such that the equipment still complies with the e.i.r.p. limits specified for point-to-point and non-point-to-point operation as appropriate.

le gain maximal d'antenne permis (pour les dispositifs utilisant la bande 5725-5850 MHz) doit se conformer à la limite de p.i.r.e. spécifiée pour l'exploitation point à point et non point à point, selon le cas.

Dynamic Frequency Selection (DFS) for devices operating in the bands 5250- 5350 MHz, 5470-5600 MHz and 5650-5725 MHz.



Sélection dynamique de fréquences (DFS) pour les dispositifs fonctionnant dans les bandes 5250-5350 MHz, 5470-5600 MHz et 5650-5725 MHz.

The maximum antenna gain permitted for devices in the bands 5250-5350 MHz and 5470-5725 MHz shall be such that the equipment still complies with the e.i.r.p. limit.  
le gain maximal d'antenne permis pour les dispositifs utilisant les bandes 5250-5350 MHz et 5470-5725 MHz doit se conformer à la limite de p.i.r.e.

Users should also be advised that high-power radars are allocated as primary users (i.e. priority users) of the bands 5250-5350 MHz and 5650-5850 MHz and that these radars could cause interference and/or damage to LE-LAN devices.

De plus, les utilisateurs devraient aussi être avisés que les utilisateurs de radars de haute puissance sont désignés utilisateurs principaux (c.-à-d., qu'ils ont la priorité) pour les bandes 5250-5350 MHz et 5650-5850 MHz et que ces radars pourraient causer du brouillage et/ou des dommages aux dispositifs LAN-EL.

Pour une utilisation en intérieur uniquement.

#### IMPORTANT NOTE:

##### IC Radiation Exposure Statement:

This equipment complies with IC RSS-102 radiation exposure limits set forth for an uncontrolled environment. This equipment should be installed and operated with minimum distance 20 cm between the radiator & your body.

Cet équipement est conforme aux limites d'exposition aux rayonnements IC établies pour un environnement non contrôlé. Cet équipement doit être installé et utilisé avec un minimum de 20 cm de distance entre la source de rayonnement et votre corps.

This module is intended for OEM integrator. The OEM integrator is still responsible for the IC compliance requirement of the end product, which integrates this module.

Any changes or modifications not expressly approved by the manufacturer could void the user's authority to operate this equipment.

#### USERS MANUAL OF THE END PRODUCT:

In the users manual of the end product, the end user has to be informed to keep at least 20 cm separation with the antenna while this end product is installed and operated. The end

user has to be informed that the IC radio-frequency exposure guidelines for an uncontrolled environment can be satisfied. The end user has to also be informed that any changes or modifications not expressly approved by the manufacturer could void the user's authority to operate this equipment. Operation is subject to the following two conditions: (1) this device may not cause harmful interference and (2) this device must accept any interference received, including interference that may cause undesired operation.

**LABEL OF THE END PRODUCT:**

The final end product must be labeled in a visible area with the following " Contains TX IC: 4491A-WCBN4515R ".