



## Bluetooth Module - Part Code LM-400



Top view



Bottom view

### Contents:

1. Device Overall Description
2. Bluetooth
  - Features
  - Specification Compliance
  - Bluetooth Block Diagram
  - Modulation Methods
  - Power Consumption
  - RF Characteristics
3. Pinout and Definition
4. Mechanical Dimension

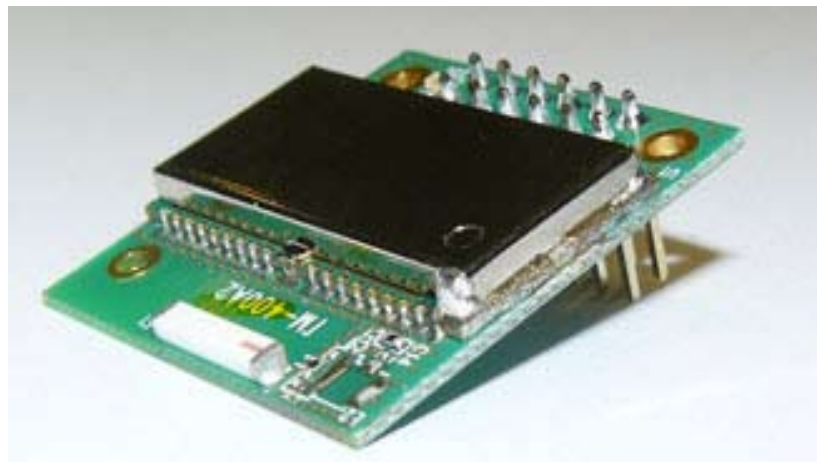

Side view



## Device Overall Description

The BTM400 is designed to provide Bluetooth2.0 + EDR function on a small form factor. The Bluetooth function is based on CSR BlueCore4-Ext Bluetooth System, which implements the full speed class 1 Bluetooth operations with full 7 slave piconet support. The interface of BTM400 to host system is UART.

## Bluetooth

### Features

- CSR BlueCore4
- Bluetooth 2.0 + EDR support
- Full Speed Class 1 Bluetooth operation with full 7 slave piconet support
- Single onboard Antenna connector support (Optional)
- Chip antenna on board

### Bluetooth Block Diagram

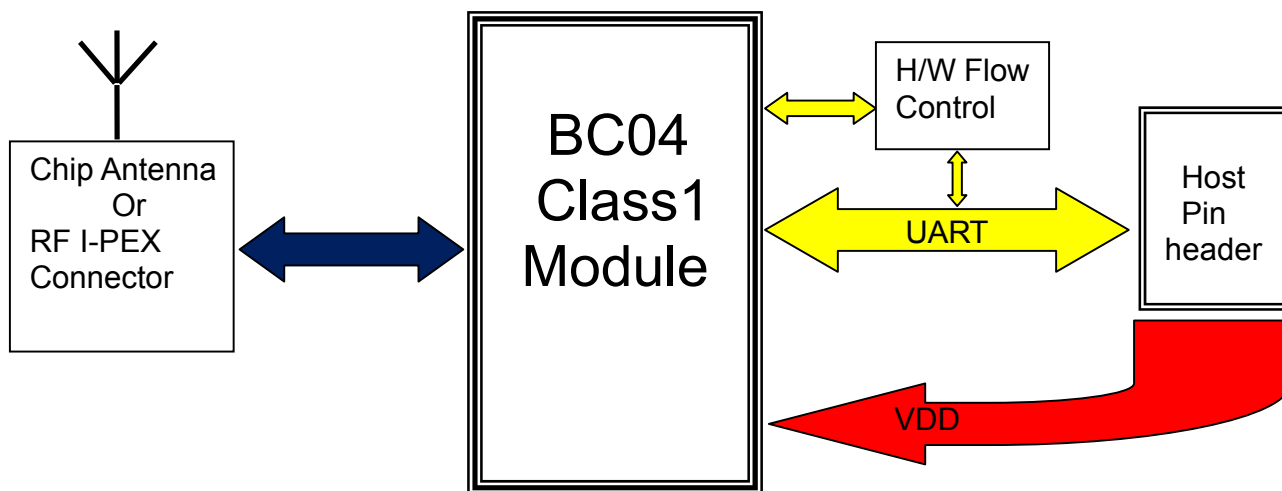

### Modulation Methods

FHSS ( Frequency Hopping Spread Spectrum ) defined in Bluetooth Specification.

	Data Rate	Modulation scheme
Basic Data Rate	1 Mbps	GFSK
Enhanced Data Rate	2Mbps	$\pi/4$ – DQPSK
	3Mbps	8DPSK



## Bluetooth Power Consumption

Absolute Maximum Ratings					
Parameter	Min.	Max.	Unit		
Storage Temperature	-40	+85	°C		
Supply Voltage(VDD)	2.7	3.6	DCV		
Supply Voltage(PVCC)	3.0	3.3	DCV		
Other Pin Voltage	Vss-0.4	VDD+0.4	DCV		
Recommended Operating Conditions					
Parameter	Min.	Max.	Unit		
Temperature	-10	+70	°C		
Supply Voltage for UART	3.0	3.6	DCV		
Supply Voltage for USB	3.0	3.6	DCV		
General Electrical Specification					
Parameter	Description	Min.	Typ.	Max.	Unit
Carrier Frequency		2.402		2.480	GHz
RF Output Power	Measured in 50ohm	15	16.5	18	dBm
RX sensitivity		-	-88	-86	dBm
Load Impedance	No abnormal Oscillation			5:1	
Input Low Voltage	RESET,UART,GPIO,PCM	-0.30	-	0.80	DCV
Input High Voltage	RESET,UART,GPIO,PCM	0.7VDD	-	VDD+0.3	DCV
Output Low Voltage	UART,GPIO,PCM	-	-	0.40	DCV
Output High Voltage	UART,GPIO,PCM	VDD-0.4	-	-	DCV
Average Current Consumption	Receive DM1		114		mA

## Radio Characteristics - Basic Data Rate

Transmitter , VDD = 3.3V Temperature =+20°C						
	Frequency (GHz)	Min.	Typ.	Max.	Bluetooth Specification	Unit
Maximum RF transmit power <sup>(note)</sup>	2.402	-	6	-	-6 to +20	dBm
	2.441	-	6	-		dBm
	2.480	-	7	-		dBm
Relative transmit power		-	-1.6	-	-4 to +1	dB
$\pi/4$ DQPSK Maximum carrier frequency stability $w_0$		-	2	-	$\leq \pm 10$ for all blocks	kHz
$\pi/4$ DQPSK Maximum carrier frequency stability $w_i$		-	6	-	$\leq \pm 75$ for all packets	kHz
$\pi/4$ DQPSK Maximum carrier frequency stability $ w_0 + w_i $		-	8	-	$\leq \pm 75$ for all blocks	kHz
8 DPSK Maximum carrier frequency stability $w_0$		-	2	-	$\leq \pm 10$ for all blocks	kHz
8 DPSK Maximum carrier frequency stability $w_i$		-	6	-	$\leq \pm 75$ for all packets	kHz
8 DPSK		-	8	-	$\leq \pm 75$ for all blocks	kHz



Maximum carrier frequency stability   $w_0 + w_i$						
$\pi/4$ DQPSK Modulation Accuracy	RMS DVEM	-	7	-	$\leq 20$	%
	99% DEVM	-	13	-	$\leq 30$	%
	Peak DEVM	-	19	-	$\leq 35$	%
8 DPSK Modulation Accuracy	RMS DVEM	-	7	-	$\leq 13$	%
	99% DEVM	-	13	-	$\leq 20$	%
	Peak DEVM	-	17	-	$\leq 25$	%
In-band spurious emissions	$F > F_0 + 3$ MHz	-	$< -50$	-	$\leq -40$	dBm
	$F < F_0 - 3$ MHz	-	$< -50$	-	$\leq -40$	dBm
	$F = F_0 - 3$ MHz	-	-46	-	$\leq -40$	dBm
	$F = F_0 - 2$ MHz	-	-34	-	$\leq -20$	dBm
	$F = F_0 - 1$ MHz	-	-35	-	$\leq -26$	dBm
	$F = F_0 + 1$ MHz	-	-35	-	$\leq -26$	dBm
	$F = F_0 + 2$ MHz	-	-31	-	$\leq -20$	dBm
EDR Differential Phase Encoding			No Errors		$\geq 99$	%

**Receiver , VDD = 3.3V Temperature = +20°C**

	Modulation	Min.	Typ.	Max.	Bluetooth Specification	Unit
Sensitivity at 0.1% BER	$\pi/4$ DQPSK	-	-87	-	$\leq -70$	dBm
	8 DPSK	-	-78	-	$\leq -70$	dBm
Maximum received signal level at 0.1% BER	$\pi/4$ DQPSK	-	-8	-	$\geq -20$	dBm
	8 DPSK	-	-10	-	$\geq -20$	dBm
C/I co-channel at 0.1% BER	$\pi/4$ DQPSK	-	10	-	$\leq +13$	dB
	8 DPSK	-	19	-	$\leq +21$	dB
Adjacent channel selectivity C/I $F = F_0 + 1$ MHz	$\pi/4$ DQPSK	-	-10	-	$\leq 0$	dB
	8 DPSK	-	-5	-	$\leq +5$	dB
Adjacent channel selectivity C/I $F = F_0 - 1$ MHz	$\pi/4$ DQPSK	-	-11	-	$\leq 0$	dB
	8 DPSK	-	-5	-	$\leq +5$	dB
Adjacent channel selectivity C/I $F = F_0 + 2$ MHz	$\pi/4$ DQPSK	-	-40	-	$\leq -30$	dB
	8 DPSK	-	-40	-	$\leq -25$	dB
Adjacent channel selectivity C/I $F = F_0 - 2$ MHz	$\pi/4$ DQPSK	-	-23	-	$\leq -20$	dB
	8 DPSK	-	-20	-	$\leq -13$	dB
Adjacent channel selectivity C/I $F = F_0 + 3$ MHz	$\pi/4$ DQPSK	-	-45	-	$\leq -40$	dB
	8 DPSK	-	-45	-	$\leq -33$	dB
Adjacent channel selectivity C/I $F = F_0 - 5$ MHz	$\pi/4$ DQPSK	-	-45	-	$\leq -40$	dB
	8 DPSK	-	-45	-	$\leq -33$	dB
$F_0 = 2405, 2441, 2477$ MHz						
Adjacent channel selectivity C/I $F = F_{\text{image}}$	$\pi/4$ DQPSK		-20		$\leq -7$	dB
	8 DPSK		-15		$\leq 0$	dB

Note Measurement made using a POWER\_TABLE entry of TX\_PRE 80, INT PA63, EXT PA255. This ensures that the Bluetooth requirements for ACP and those defined by the FCC and ETSI are satisfied over the operating temperature range of  $-5\text{D}$  to  $+45\text{D}$ . Although the design is capable of generating in excess of  $+18\text{dBm}$ , regulatory compliance over the full temperature range of  $-5\text{D}$  to  $+45\text{D}$  will not be satisfied if the transmit power approaches this value.



## Radio Characteristics – Enhanced Data Rate

Transmitter , VDD = 3.3V Temperature =+20°C						
	Frequency (GHz)	Min.	Typ.	Max.	Bluetooth Specification	Unit
Maximum RF transmit power <sup>(note)</sup>	2.402	-	6	-	-6 to +20	dBm
	2.441	-	6	-		dBm
	2.480	-	7	-		dBm
Relative transmit power		-	-1.6	-	-4 to +1	dB
$\pi/4$ DQPSK Maximum carrier frequency stability $w_0$		-	2	-	$\leq \pm 10$ for all blocks	kHz
$\pi/4$ DQPSK Maximum carrier frequency stability $w_i$		-	6	-	$\leq \pm 75$ for all packets	kHz
$\pi/4$ DQPSK Maximum carrier frequency stability $ w_0 + w_i $		-	8	-	$\leq \pm 75$ for all blocks	kHz
8 DPSK Maximum carrier frequency stability $w_0$		-	2	-	$\leq \pm 10$ for all blocks	kHz
8 DPSK Maximum carrier frequency stability $w_i$		-	6	-	$\leq \pm 75$ for all packets	kHz
8 DPSK Maximum carrier frequency stability $ w_0 + w_i $		-	8	-	$\leq \pm 75$ for all blocks	kHz
$\pi/4$ DQPSK Modulation Accuracy	RMS DVEM	-	7	-	$\leq 20$	%
	99% DEVM	-	13	-	$\leq 30$	%
	Peak DEVM	-	19	-	$\leq 35$	%
8 DPSK Modulation Accuracy	RMS DVEM	-	7	-	$\leq 13$	%
	99% DEVM	-	13	-	$\leq 20$	%
	Peak DEVM	-	17	-	$\leq 25$	%
In-band spurious emissions	$F > F_0 + 3$ MHz	-	<-50	-	$\leq -40$	dBm
	$F < F_0 - 3$ MHz	-	<-50	-	$\leq -40$	dBm
	$F = F_0 - 3$ MHz	-	-46	-	$\leq -40$	dBm
	$F = F_0 - 2$ MHz	-	-34	-	$\leq -20$	dBm
	$F = F_0 - 1$ MHz	-	-35	-	$\leq -26$	dBm
	$F = F_0 + 1$ MHz	-	-35	-	$\leq -26$	dBm
	$F = F_0 + 2$ MHz	-	-31	-	$\leq -20$	dBm
$F = F_0 + 3$ MHz	-	-33	-	$\leq -40$	dBm	
EDR Differential Phase Encoding			No Errors		$\geq 99$	%
Receiver , VDD = 3.3V Temperature =+20°C						
	Modulation	Min.	Typ.	Max.	Bluetooth Specification	Unit
Sensitivity at 0.1% BER	$\pi/4$ DQPSK	-	-87	-	$\leq -70$	dBm
	8 DPSK	-	-78	-	$\leq -70$	dBm
Maximum received signal level at 0.1% BER	$\pi/4$ DQPSK	-	-8	-	$\geq -20$	dBm
	8 DPSK	-	-10	-	$\geq -20$	dBm
C/I co-channel at 0.1% BER	$\pi/4$ DQPSK	-	10	-	$\leq +13$	dB
	8 DPSK	-	19	-	$\leq +21$	dB
Adjacent channel selectivity C/I $F = F_0 + 1$ MHz	$\pi/4$ DQPSK	-	-10	-	$\leq 0$	dB
	8 DPSK	-	-5	-	$\leq +5$	dB



Adjacent channel selectivity C/I F=F <sub>0</sub> -1 MHz	$\pi/4$ DQPSK	-	-11	-	$\leq 0$	dB
	8 DPSK	-	-5	-	$\leq +5$	dB
Adjacent channel selectivity C/I F=F <sub>0</sub> +2 MHz	$\pi/4$ DQPSK	-	-40	-	$\leq -30$	dB
	8 DPSK	-	-40	-	$\leq -25$	dB
Adjacent channel selectivity C/I F=F <sub>0</sub> -2 MHz	$\pi/4$ DQPSK	-	-23	-	$\leq -20$	dB
	8 DPSK	-	-20	-	$\leq -13$	dB
Adjacent channel selectivity C/I F=F <sub>0</sub> +3 MHz	$\pi/4$ DQPSK	-	-45	-	$\leq -40$	dB
	8 DPSK	-	-45	-	$\leq -33$	dB
Adjacent channel selectivity C/I F=F <sub>0</sub> -5 MHz	$\pi/4$ DQPSK	-	-45	-	$\leq -40$	dB
	8 DPSK	-	-45	-	$\leq -33$	dB
F <sub>0</sub> = 2405, 2441, 2477 MHz						
Adjacent channel selectivity C/I F=F <sub>image</sub>	$\pi/4$ DQPSK		-20		$\leq -7$	dB
	8 DPSK		-15		$\leq 0$	dB

**Pinout and Definition**

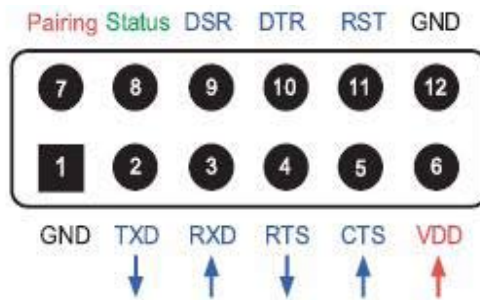

Pin no.	Pin name	Direction	Description	Signal Lev
1	GND		Power Ground	Ground
2	TXD	Output	UART data out	TTL
3	RXD	Input	UART data input	TTL
4	RTS	Output	UART Ready to Send	TTL
5	CTS	Input	UART Clear to Send	TTL
6	VDD	Input	DC input (3.0 ~ 3.3V)	Power
7	Pairing	Input	Pairing input (Active Low)	TTL
8	Status	Output	Bluetooth Connect Detect (Active Low)	TTL
9	DSR	Input	Data Set Ready	TTL
10	DTR	Output	Data Terminal Ready	TTL
11	RST	Input	Reset (Active Low)	TTL
12	GND		Power Ground	Ground



**Mechanical Dimension**

-30mm x 27.5mm (L x W) +- 0.15mm

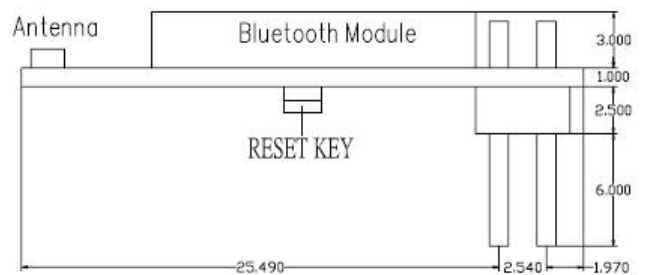
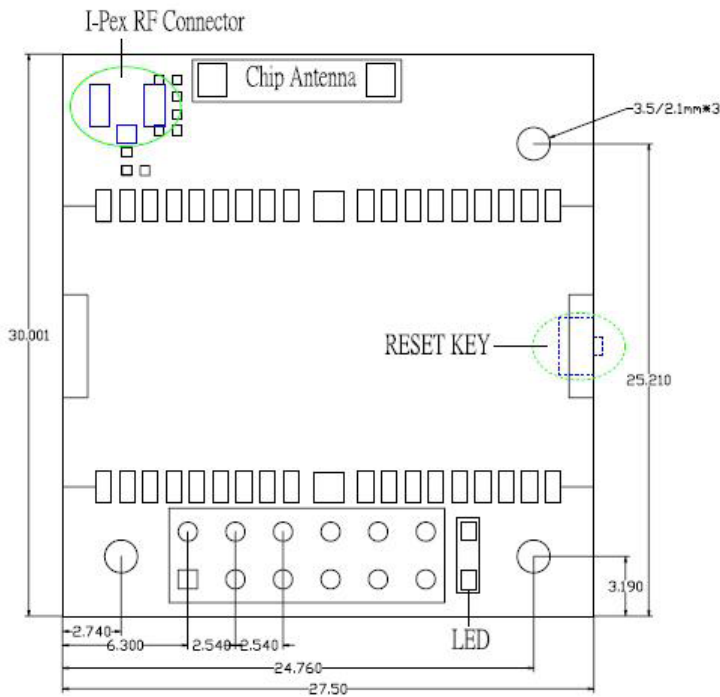

-Component height (unit: mm)

**Notes :**

1. PIN9,10 DSR/DTR don't use, they are no function currently.
2. PIN5 Pairing, the function have been changed to Data led indication
3. PIN6 Status, the function have not been specified.
4. RESET KEY

By pressing the Reset button, you can:

- Disconnect and reconnect a wireless connection (a short press).
- Restore the factory COM port 19200bps settings (over three seconds' press).

5. LED

Bluetooth link status



Pin No.	Pin Name	Pin Type	Description
1	GND	GND	Common ground
2	PVCC	Power	Power Amp. Power Supply(3.3V)
3	AIO (0)	Bi-directional	Programmable I/O terminal , 32KHz sleep clock input
4	AIO (1)	Bi-directional	Programmable I/O terminal
5	PIO (0)	Bi-directional	Programmable I/O terminal , RX Enable
6	PIO (1)	Bi-directional	Programmable I/O terminal , TX Enable
7	PIO (2)	Bi-directional	Programmable I/O terminal , USB_PULL_UP , CLK_REQ_OUT
8	PIO (3)	Bi-directional	Programmable I/O terminal , USB_WAK E_UP , CLK_REQ_IN
9	PIO (4)	Bi-directional	Programmable I/O terminal , USB_ON , <b>BT_Priority/Ch_Clk output for co-existence signalling</b>
10	GND	GND	Common ground
11	PIO (5)	Bi-directional	Programmable I/O terminal , USB_DETACH , <b>BT_Active output for co-existence signalling</b>
12	PIO (6)	Bi-directional	Programmable I/O terminal , CLK_REQ , <b>WLAN_Active/Ch_Data input for for co-existence signalling</b>
13	PIO (7)	Bi-directional	Programmable I/O terminal
14	PIO (8)	Bi-directional	Programmable I/O terminal
15	PIO (9)	Bi-directional	Programmable I/O terminal
16	RESET	CMOS input	Reset input of module, Active low reset
17	VCC	Power	Module power supply input
18	GND	GND	Common ground
19	GND	GND	Common ground
20	USB_DP	Bi-directional	USB data plus
21	USB_DN	Bi-directional	USB data minus
22	PCM_SYNC	Bi-directional	Synchronous data sync
23	PCM_IN	CMOS input	Synchronous data input
24	PCM_OUT	CMOS output	Synchronous data output
25	PCM_CLK	Bi-directional	Synchronous data clock
26	UART_RX	CMOS input	UART data input
27	UART_TX	CMOS output	UART data output
28	UART_RTS	CMOS output	UART request to send(active low)
29	GND	GND	Common ground
30	UART_CTS	CMOS input	UART clear to send(active low)
31	SPI_MOSI	CMOS input	Serial Peripheral Interface data input
32	SPI_CSB	CMOS input	Chip select for Synchronous Serial Interface(active low)
33	SPI_CLK	CMOS input	Serial Peripheral Interface clock
34	SPI_MISO	CMOS output	Serial Peripheral Interface data output
35	PIO (11)	Bi-directional	Programmable I/O terminal
36	PIO (10)	Bi-directional	Programmable I/O terminal
37	RF_IO	Analogue	Antenna interface
38	GND	GND	Common ground



This device complies with the following radio frequency and safety standards.

**Important to OEM Manufacturer:**

**This following FCC Warning must be included in the HOST User Manual.**

**FCC Warning**

This device complies with Part 15 of the FCC Rules. Operation is subject to the following two conditions:

(1) this device may not cause harmful interference, and (2) this device must accept any interference received, including interference that may cause undesired operation.

NOTE 1: Any changes or modifications to this unit not expressly approved by the party responsible for compliance could void the user's authority to operate the equipment.

**FCC Radiation Exposure Statement:**

This equipment complies with FCC radiation exposure limits set forth for an uncontrolled environment. End users must follow the specific operating instructions for satisfying RF exposure compliance.

**Note 1:** This module certified that complies with RF exposure requirement under mobile or fixed condition, this module is to be installed only in portable or mobile or fixed applications.

A mobile device is defined as a transmitting device designed to be used in other than fixed locations and to generally be used in such a way that a separation distance of at least 20 centimeters is normally maintained between the transmitter's radiating structure(s) and the body of the user or nearby persons. Transmitting devices designed to be used by consumers or workers that can be easily re-located, such as wireless devices associated with a personal computer, are considered to be mobile devices if they meet the 20 centimeter separation requirement.

A fixed device is defined as a device is physically secured at one location and is not able to be easily moved to another location.

**Note 2:** Any modifications made to the module will void the Grant of Certification, this module is limited to OEM installation only and must not be sold to end-users, end-user has no manual instructions to remove or install the device, only software or operating procedure shall be placed in the end-user operating manual of final products.

**Note 3:** The device must not transmit simultaneously with any other antenna or transmitter.

**Note 4:** To ensure compliance with all non-transmitter functions the host manufacturer is responsible for ensuring compliance with the module(s) installed and fully operational. For

example, if a host was previously authorized as an unintentional radiator under the Declaration of Conformity procedure without a transmitter certified module and a module is added, the host manufacturer is responsible for ensuring that after the module is installed and operational the host continues to be compliant with the Part 15B unintentional radiator requirements. Since this may depend on the details of how the module is integrated with the host, LM Technologies Ltd. shall provide guidance to the host manufacturer for compliance with the Part 15B requirements.

**Note 5:** FCC ID label on the final system must be labeled with “Contains FCC ID: VVXLM400-1” or “Contains transmitter module FCC ID: VVXLM400-1”.

The transmitter module must be installed and used in strict accordance with the manufacturer's instructions as described in the user documentation that comes with the host product. LM Technologies Ltd. is responsible for the compliance of the module in all final hosts.