

LX
navigation

Eos 80 user's manual



LX Eos 80

User's manual
(version 0.9H)

Refers to LX Eos 80 FW version 0.9H

For standalone use and for use in an LX Zeus configuration.

CONTENTS

PART ONE – INTRODUCTION	4
1.1 Preamble	4
1.2 Introduction	5
1.3 Operation	7
PART TWO – INSTALLATION.....	8
2.1 Mechanical installation.....	8
2.2 Pneumatic connections	8
2.3 Electrical installation.....	9
2.4 External switch installation	10
2.5 Installation options	11
Configurations.....	11
LX Eos – OUDIE.....	11
LX Eos – Flarm	11
LX Eos – Flarm – OUDIE	11
LX Eos – Flarm – OUDIE – 2 nd seat –2 nd OUDIE	12
Wirings for radio	13
2.6 Update procedure	14
2.7 Technical specifications	14
PART THREE – INTERFACE.....	15
Front panel interface	15
PART FOUR – SOFTWARE.....	17
4 Main pages.....	17
4.1 Vario page	19
4.2 Thermal assistant page.....	20
4.3 Flarm radar page.....	21
4.3.1 Flarm select.....	21
4.3.2 Flarm warning	21
4.4 TP navigation page.....	22
4.5 Airport navigation page.....	23
4.6 Task navigation page	24
4.7 G-Force page.....	25
4.8 GPS info page	26
4.9 Logbook / statistic page.....	26
4.9.1 Logbook	26
4.10 Statistic.....	27
4.11 Setup.....	28
4.11.1 Pilot.....	28
4.11.2 Vario/SC.....	29

4.11.3	Polar	30
4.11.4	Units	31
4.11.5	Indicators	32
4.11.6	Logger.....	33
4.11.7	Warnings	33
4.11.8	Voice.....	34
4.11.9	Transfer	35
4.11.10	Inputs.....	38
4.11.11	NMEA.....	39
4.11.12	Pages	40
4.11.13	Password	40
4.11.14	Info	40
4.11.15	Shutdown	40
PART FIVE – CONNECTIVITY		41
5	Wi-Fi/Bluetooth module	41
5.1	Pairing with PNA and Android devices	41
5.2	Supported data transfers	41
5.3	Usage.....	41
6	User port.....	41
6.1	Supported data transfers	42
7	SD card	42
Additional information		42
PART FIVE – FLYING WITH EOS		45
Flight preparation on ground		45
Before take off		45
During flight.....		45
Set QNH		45
Wind calculation		45
Influence of wind in final glide		45
Event function.....		46
Task start		46
After landing.....		46
Downloading flights.....		46
Revision history		47

PART ONE – INTRODUCTION

1.1 Preamble

Why LX Navigation?

LX Navigation is one of the oldest glider navigation brands. Its founders started experimenting with glider computers way back in the '70-ies and the Company has been working on improving your flight performance ever since.

Throughout the last 40 years or so it has been working on instruments that most pilots will have used at some time. In fact our equipment can be found in almost any gliding club!

Our equipment has always been ground-breaking.

Our motto?

Be the first. Be the best. Be different.

Why Eos 80?

Because the Eos is a junction of old-school analogue style and full function possibilities of the large transfective LCD screen.

A state-of -the-art vario unit, leading the way for technology innovation in the field of sensorics, gathering information, processing and helping the pilot with clear, clean and intuitive interface.

We keep the most important function of the vario – showing lift and sink – on an analogue, high contrast needle and still manage to spoil you with all the information a pilot could require for his everyday cross-country, competition or club flight.

Devices

We offer a wide range of instruments suitable for both club and competition soaring.

Our systems combine two components:

First, a glider computer (LX Zeus) which is used for calculating and displaying all of the key information used by pilots. This glider computer is the brain of the operation.

The second part of the system is a variometer (Eos, Helios, and Era). Its job is to gather the information which the Zeus uses. The vario has pressure connections as well as the GPS antenna connection which is required for IGC logs.

There is a wide variety of choice for varios and for LX Zeus display sizes.

All our variors are standalone devices which can be used without a glider computer for displaying basic flight parameters such as final glide information, Speed Command (SC) as well as simple navigation. Our variors also have an internal battery which means that your IGC logs do not depend on your glider's batteries.

System extensions (second seat unit, remote control (LX Joy), compass, NavBox, MOP, Flap sensor, AHRS ...) are also possible. Everything is connected using a CAN bus (single cable for power and data). All connections are plug and play, which means no specialist is required to install the system.

1.2 Introduction

The LX Eos 80 is an "all-in one" standalone speed to fly variometer, flight recorder, final glide calculator and navigation system with an internal backup battery, audio warnings, vario beeps and voice messages. The unit is capable of providing APT (airport), TP (turnpoint) and TSK (task) navigation on three dedicated navigational pages. Navigation pages feature Navboxes showing bearing to point, track, distance and final glide with graphically show airspaces, airports and turnpoints.

Th vario is designed to fit a standard 80mm aviation cut-out hole. It is able to supply PDA/PNA units with 5 V/500 mA and 3.3 V/100 mA output on User output connector.

LX Eos 80 has built-in high precision digital sensors based on latest MEMS technology for altitude, vario, speed, 3-axis gyro and 3-axis accelerometer sensorics. All sensors are sampled with more than 100Hz sample rate.

The mechanical needle can be assigned to show one of multiple parameters (vario, netto, g-force, speed command etc.). By default, it is showing vario value.

As an integral part, it has a 2.7" sunshine readable transfective LCD display to show all user defined data during flight. For accessing all system options, a rotary switch with a push knob is used. A voice module is also built in for audio warnings.

A double seater installation is possible by installing an LX Eos 80 Repeater and connecting it to the system via CAN bus.

An integral IGC approved flight recorder with ENL level detector will record flight to internal solid-state memory (8GB). All flights can be copied to an external SD card after flight.

For backup and safety reason, it has an internal battery, which will work for about three to five hours after main power supply is disconnected. Integral charger will charge up backup battery when external power supply is connected (12V).

LX Eos 80 features are:

- 2.7" transfective technology sunlight readable display
- Integrated G-meter (g-forces recorder)
- 3-axis gyroscope
- 3-axis accelerometers
- 50ch – GPS receiver as an integral part of the system
- Completely new design using latest pressure transducers technology
- Extremely fast vario data acquisition
- Rotary knob with push function, for simple and effective handling
- Nearly unlimited memory space for flight recorder
- ENL (Environment Noise Level) sensor

- 5 user defined status inputs (SC, VP, gear, brakes and ballast)
- OAT probe input (outside air temperature)
- Internal beeper (for Flarm warning)
- Flarm port (input of Flarm data)
- User port for PDA/PNA/Radio/transponder, supplies navigation and Flarm data to PNA/PDA
- Bluetooth interface
- Voice module as an integrated part of the system
- CAN Bus, for connection to LX Zeus or other LX devices.
- External SD Card interface, for firmware updates, flight downloads and TP/TSK/APT/Airspace transfers
- Standard 80 mm size
- The unit can be used as stand-alone, or as a part of LX Zeus system
- Built in rechargeable battery serves for three to five hours of autonomy
- Charging of battery is realized via main power
- Pre-loaded polar database

Functions:

- Variometer, TE compensation (TE probe or electronic compensation).
- Speed-to-fly function
- Final glide calculator based on GPS data (for TP and TSK)
- Complete TP/APT/TSK navigation with airspace information and warnings
- High level IGC approved flight recorder
- Flarm radar screen
- Thermal assistant screen
- System extensions: Second seat configuration, Remote control operation (LX Joy)
- Logbook
- Flight information with Barograph
- Multi pilot support
- Accurate wind calculation in straight flight and circling
- Voice announcement
- User warnings

Later in manual “backup mode” will be written from time to time. Backup mode is when LX Eos is used in LX Zeus system and while flying, system loses main power. LX Zeus will turn off, but LX Eos will use internal backup battery to continue working. All functions of LX Eos are operational in backup mode so pilot can safely navigate back to home or complete the task.

LX Eos can be used in two different configurations:

- a standalone: LX Eos represents vario navigation system and has all options active. Unit will turn on when enter switch is pressed.
- LX Zeus configuration: LX Eos serves as vario system controlled from LX Zeus. Unit will turn on automatically when main switch is turned on. All setup settings are set on LX Zeus. Flarm radar settings and thermal assistant settings must still be set on LX Eos. Some of options are disabled (setup, task edit) but all of LX Eos options will become active when backup mode is detected.

Unit has capability to be updated to any later FW release free of charge.

As standalone system, please refer to Setup/Transfer/Update, how to update the system.

As LX Zeus configuration, LX Zeus will automatically update LX Eos if required to latest version, so no extra action is required.

1.3 Operation

Switching the unit on

There are two different ways of turning the unit on.

Standalone units are turned on by pressing the push/rotary knob until the LX logo appears.

Varios meant for use alongside a Zeus, are turned on automatically when the main unit (the Zeus) is turned on.

Device name with serial number and software version information will follow after the logo appears. After boot procedure, the initial setup with pilot selection and elevation/QNH setup will be shown. If device is used in LX Zeus configuration, initial setup screen is not visible, because all initial setup is done on LX Zeus unit.



Switching the unit off

When on ground (flight recorder is not running), disconnecting the main power supply from system will turn it off. LX Eos will start to count down 3 seconds before it will turn off. You can also turn the unit off by going to the Setup page and scrolling down to Shut down. After selecting the shutdown option, you will be asked to confirm. After the confirmation, the unit will perform a 3 second countdown turn itself off.

When in flight mode (LX Eos detects IAS and flight recorder is running) it will not switch off until the flight has ended, unless the Shutdown option in Setup menu is used. Flight will end 10min after landing or manually by the user.

For instructions on how to manually end flight, please refer to section of statistic page.

PART TWO – INSTALLATION

2.1 Mechanical installation

LX Eos fits in a standard 80 mm hole in instrumental panel, so no extra cut out is required. To fit LX Eos in instrumental panel, unscrew three mounting screws (black) with a screwdriver and knob of rotary switch. To remove the knob **do not use force**. Remove the press-in cover first to get to the screw. After unscrewing the screw pull off the knob. Place the LX Eos in the hole in instrumental panel and first screw in the three black screws and then put back the knob on the rotary switch. Don't forget to screw the knob in place and put the press-in cover back on.

2.2 Pneumatic connections

Three pressure connectors are fitted to the back of LX Eos. **A label shows their functions.**

Ptot = Pitot or Total pressure

TE = TE probe

Pst = Static

Electronic TE compensation schematics (Set TE 100%)

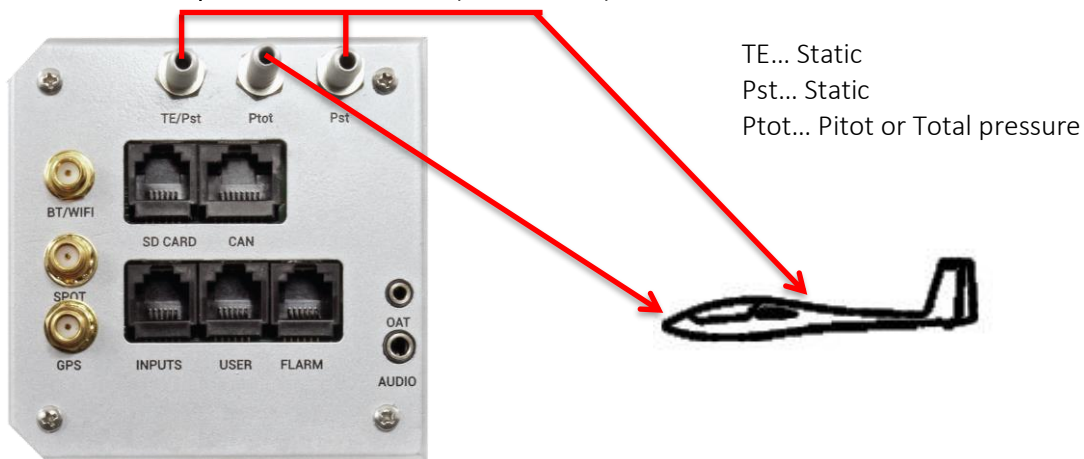

TE tube installation schematics (Set TE 0%)

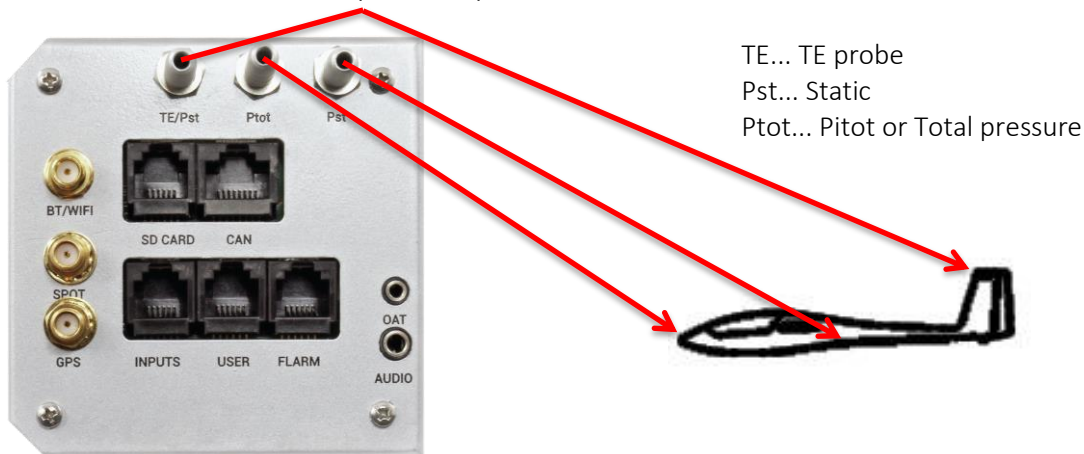

2.3 Electrical installation

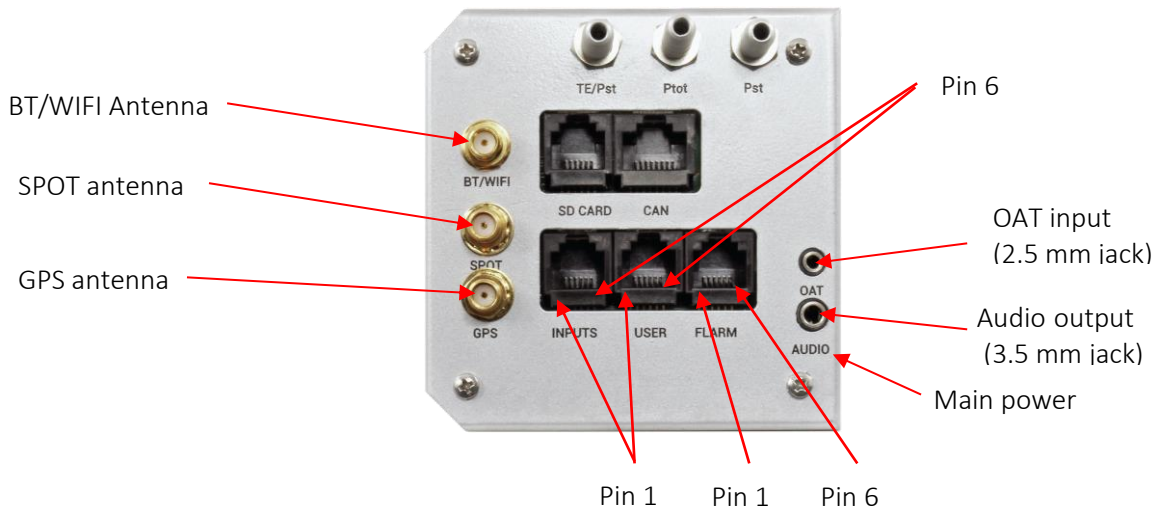

Pin out on all connectors:
Pin 1 to pin 6 or 8 (on picture from left to right).

User port (RJ11 – 6pin connector)

Pin number	Description
1	12 V out
2	Not connected
3	Not connected
4	RS 232 data in
5	RS 232 data out
6	GND

Flarm port (RJ11 – 6pin connector)

Pin number	Description
1	12 V out
2	Not connected
3	GND
4	RS 232 data in
5	RS 232 data out
6	GND

INPUT (RJ11 – 6pin connector)

Pin number	Description
1	Input 1
2	Input 2
3	Input 3
4	Input 4
5	Input 5
6	Common ground (GND)

CAN port (RJ45 – 8pin connector)

Pin number	Description
1	12 V
2	12 V
3	12 V
4	CAN_L
5	CAN_H
6	GND
7	GND
8	GND

SD port (RJ11 – 6pin connector)

Use only LX SD card adapter.

GPS antenna

Connect the external GPS antenna to this connector. The Eos must have an external antenna connected all the time, otherwise the internal flight recorder will not work.

Wi-Fi/Bluetooth antenna

Connect the external Wi-Fi/Bluetooth antenna to this connector. The Eos must have an external antenna connected all the time, otherwise Wi-Fi/Bluetooth will have no range.

SPOT antenna

The SPOT module (which is offered as an option) requires an antenna connection in order to work.

2.4 External switch installation



Up to five external switches can be connected to LX Eos. To connect external switch to LX Eos you have to use external switch interface board (included in package). Every slot available has a signal input and ground input. The configuration of inputs can be set under Setup -> Inputs.

User can use two different connection styles:

- **2 wire connection:** Connect switch signal and ground wires to interface board.

- **1 wire connection:** Connect switch ground wire to glider common ground and connect switch signal wire to interface.

Be careful not to connect signal wire to common ground input (see picture which are common ground inputs) Interfaces common ground is connected to glider common

ground via power supply cable (GND).

All inputs except SC will be “active” when switch is closed (signal and ground are in short circuit). If “Inv” (Invert) is checked on input setting then “active” means when switch is open.

Example: airbrake warning will be active when switch is not closed and Eos is in flight mode. Warning will disappear when switch will be closed.

SC input has its own setting under Vario/SC menu and can be set to be active on “on”, “off” and “toggle” state.

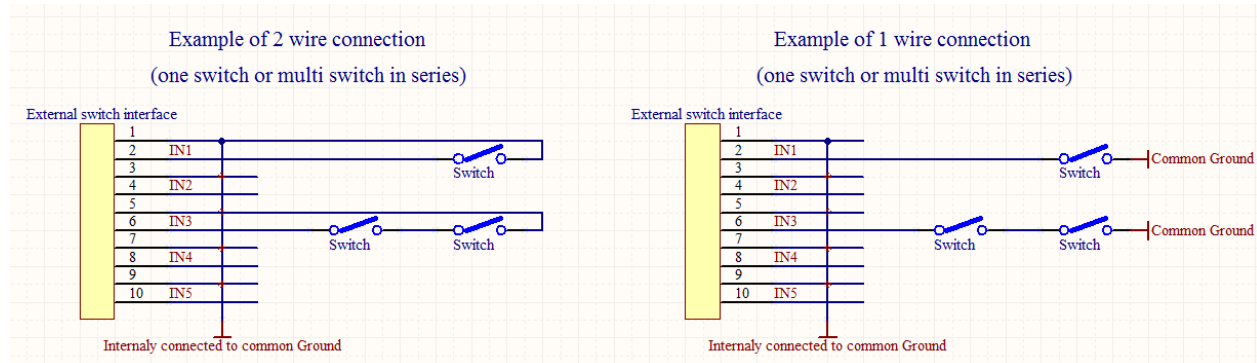

Example of both connections (1 and 2 wire)

2.5 Installation options

LX Eos is compatible with all LX CAN based devices (LX Zeus, LX Joy, LX Eos Repeater, CAN Compass, AHRS, and others). LX Eos has an integrated CAN terminator so other terminator should not be used. Only one CAN terminator should be used (be careful when using LX Eos with LX Zeus).



Configurations

LX Eos – OUDIE

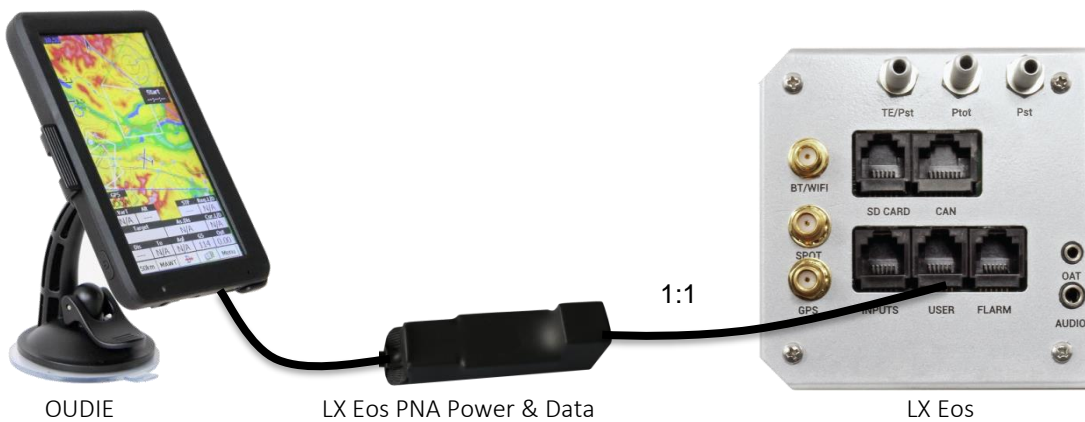

LX Eos – Flarm

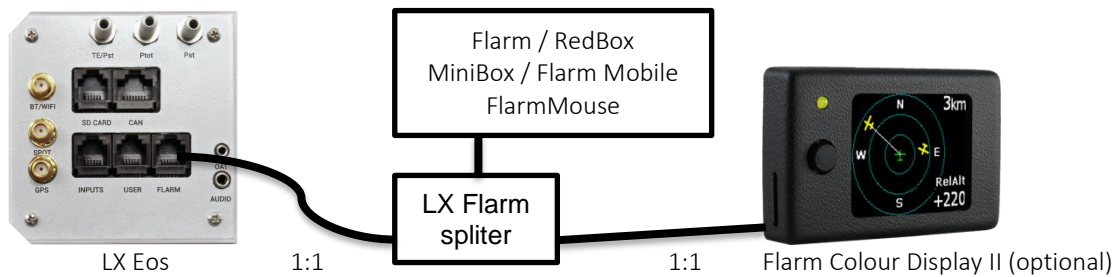

LX Eos – Flarm – OUDIE

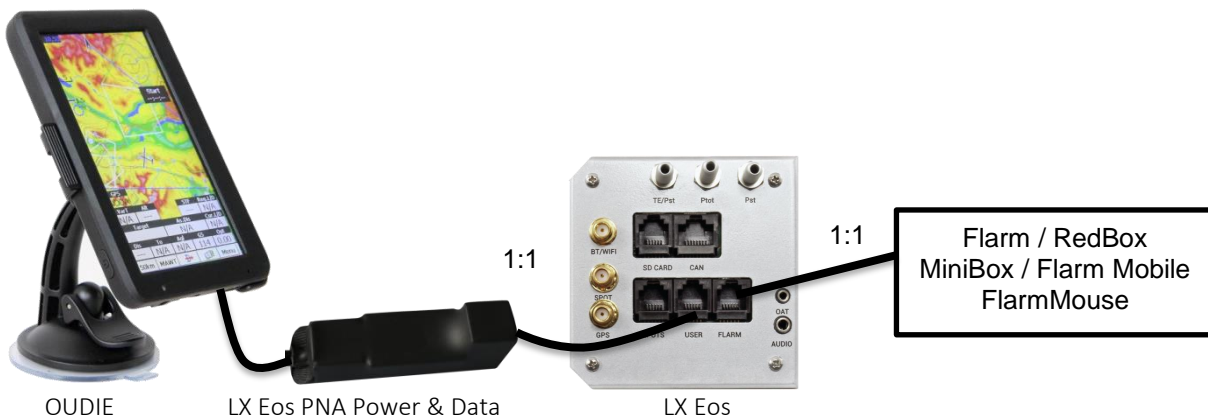

LX Eos – Flarm – OUDIE – 2nd seat – 2nd OUDIE

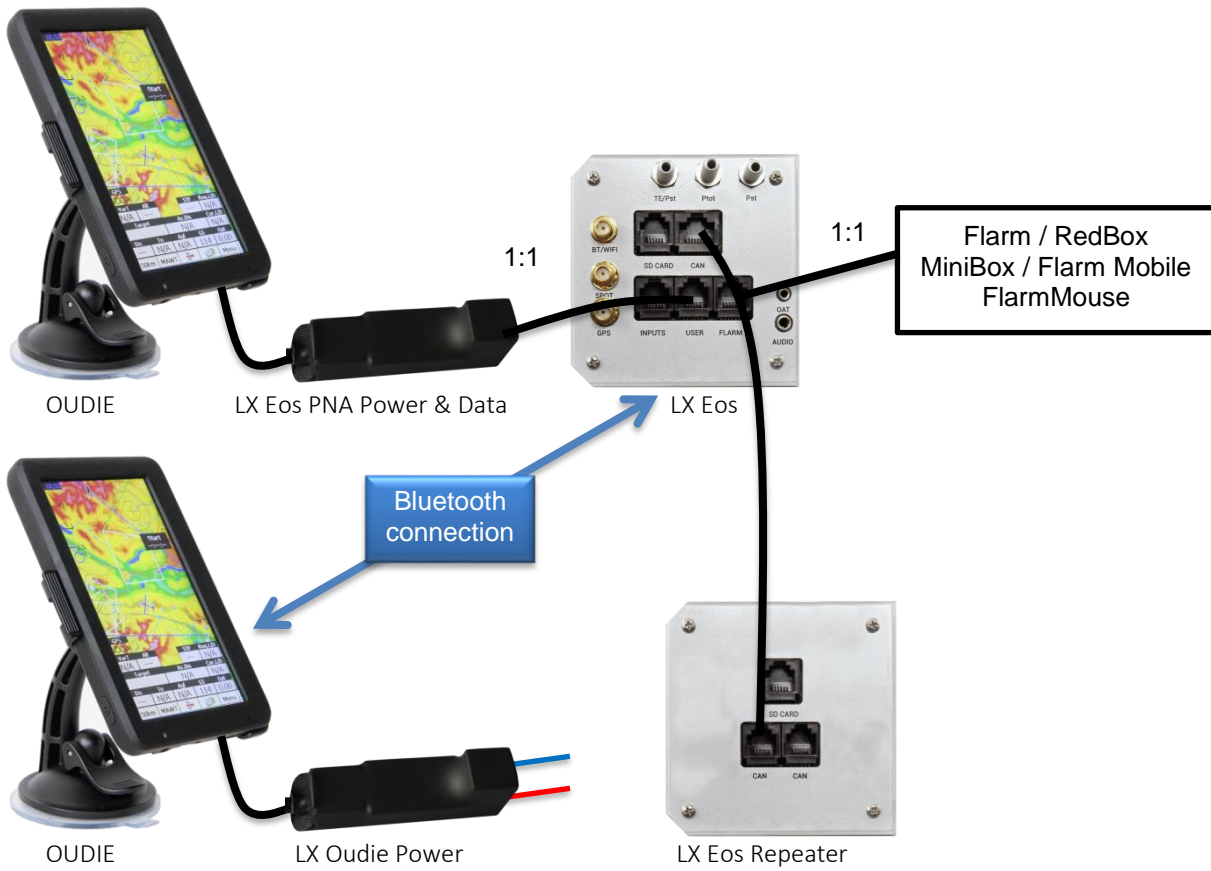

Wirings for radio

Funkwerk ATR833

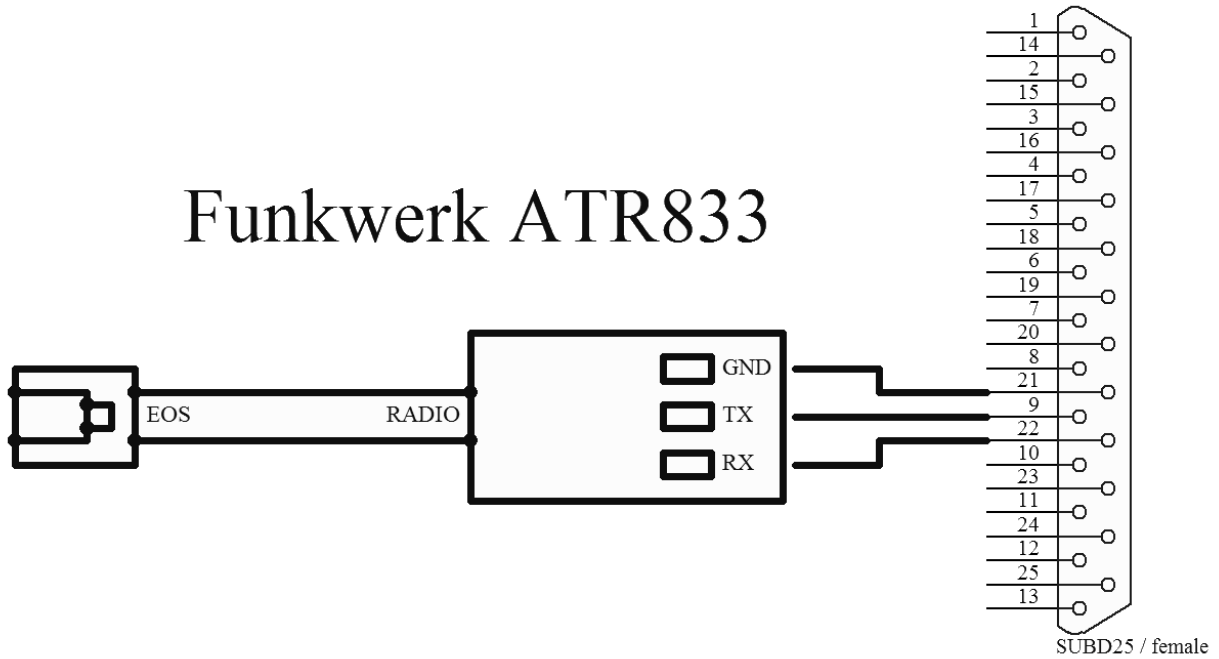

Dittel KRT2

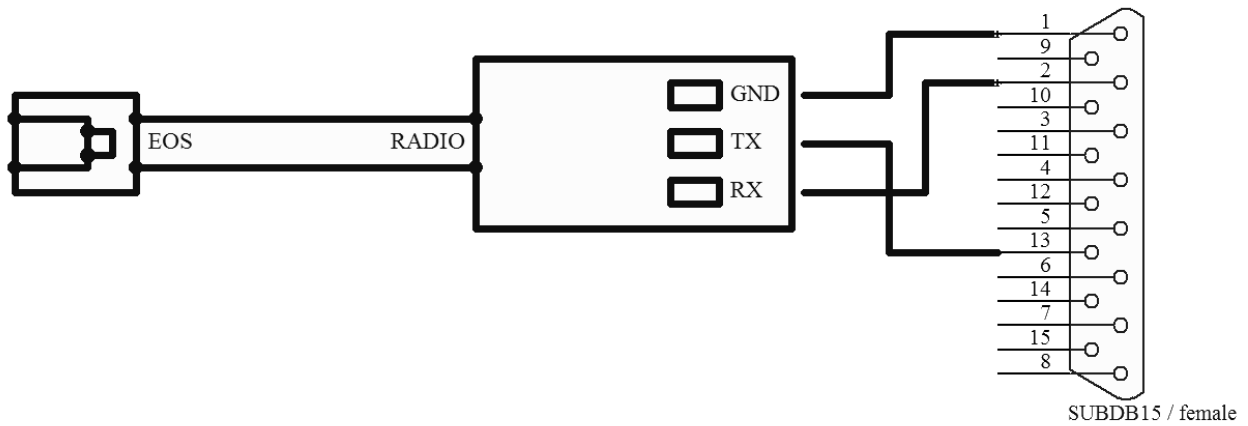

2.6 Update procedure

In order to update the device, please follow the steps below:

- Find and download the update file on www.lxnavigation.com
- Send your device's serial number to update-service@lxnavigation.si and an update code will be sent to you
- Save the downloaded update file to the supplied microSD card
- Insert the microSD card into the Eos
- Turn the device on
- Go to Setup > Transfer > Updates and select the downloaded update file
- Type in the provided password
- Copying of the file, and with it the update process, shall commence
- The device will turn off and require another turn on (if it is a standalone version. Zeus versions shall turn themselves on automatically)
- "LX updating" screen shall appear
- After the updating process has ended, the unit will start itself normally. The user should check if the correct version is displayed on the greeting screen.

Note!

First update releases (up to version 1.0) do not require an update code, hence all code related steps can be ignored. When prompted for the update password, simple type in 00000.

2.7 Technical specifications

The picture below represents the Eos 80 with all of its main components. A large 2.7-inch transfective LCD display shows all flight-relevant information to the pilot. The Eos 80 boasts an analogue needle, which clearly shows current lift, SpeedToFly or other flight parameter.

A single push/rotary knob is used for all pilot to Eos communication.



Dimensions	82 mm x 82 mm x 63 mm
Weight	290 grams
Input Voltage Range	9.0 – 18.0V DC
Average Current	150 milliamps @ 12V DC
Wi-Fi / Bluetooth range	100 metres / 20 metres

PART THREE – INTERFACE

Front panel interface

Below is a representation of the main page

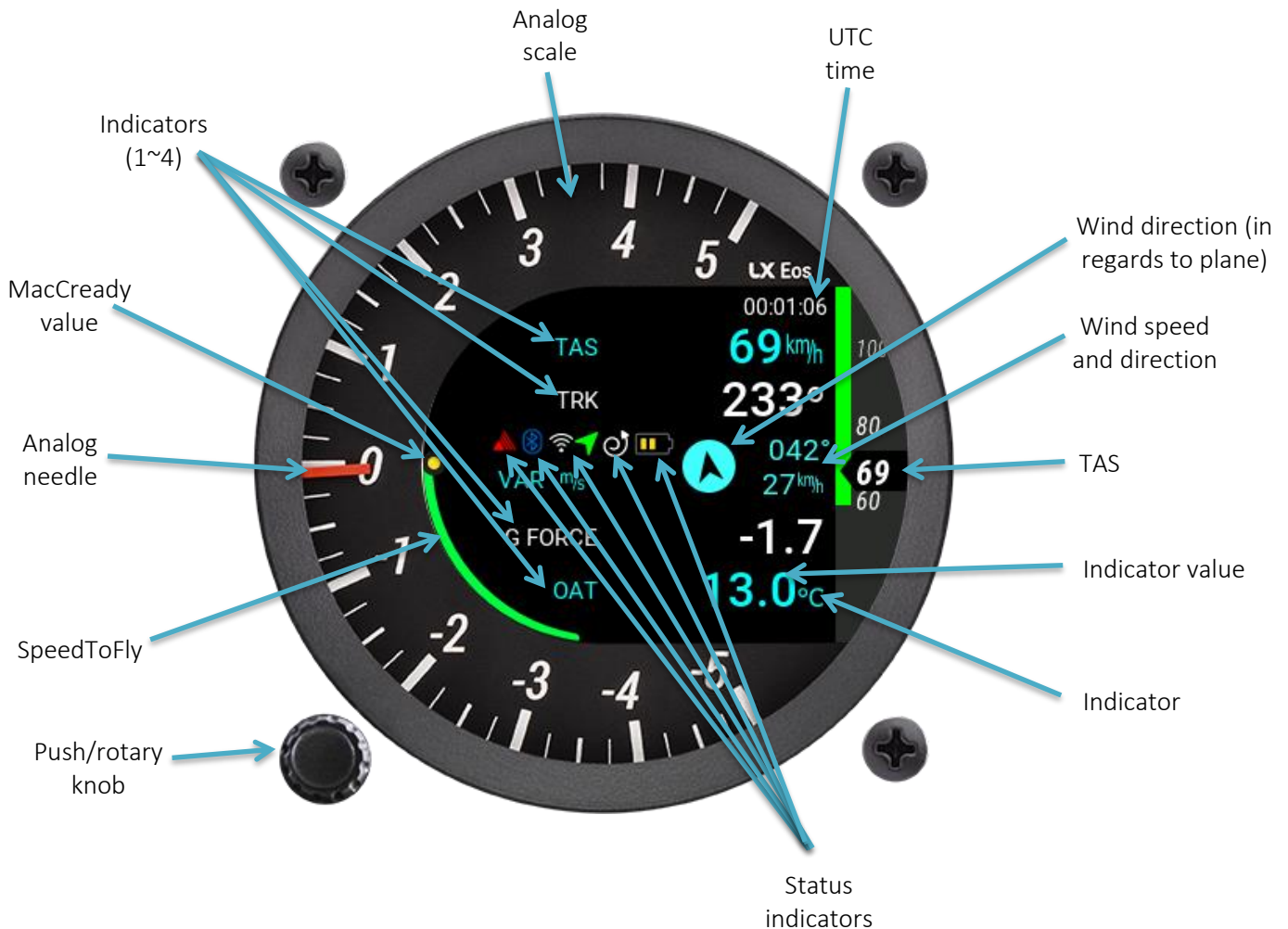

The Eos 80 features 6 status indicators, described below in their respective order:

- Flarm indicator – appears only when a Flarm device is connected to the Flarm port and communicating with the Eos
- Bluetooth indicator – appears only when a Bluetooth device is connected to the Flarm port and communicating with the Eos
- Wi-Fi indicator – appears only when a Wi-Fi device is connected to the Flarm port and communicating with the Eos
- GPS indicator – is always displayed, a green arrow indicates good GPS signal, and a red one indicates bad GPS signal
- Circling/SC mode indicator – indicates whether Eos is in Speed Command (SC) or Vario mode
- Battery status indicator – shows the current state of the airplane's battery. White battery outline indicates it is using the airplane's battery. A red battery outline indicates it is using its built-in battery

Use of rotary switch

To move around and access all functions of the unit, one rotary switch with push button is used.

Push button operation will be later in manual called as "enter".

To change value of setting, enter must be pressed to activate the rotary keyboard (appears on the left).

Use the rotary knob to input the desired value and confirm it by pressing enter.

To exit edit mode, fill out all of the fields (when a number is in question) or simply choose the enter sign (↵). For quick change (multiplication by 10 steps) press enter button and while being pressed, rotate rotary switch.

To exit from any subpage or list, a pilot has 2 options:

- Select "Exit" option which is always located at the end of each page / list
- Move to the top of each page / list where a blue circle with white a backward arrow is located (←). Exit option is activated, when this circle becomes filled with blue.

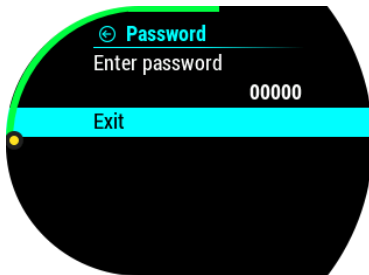

Exit at the bottom.

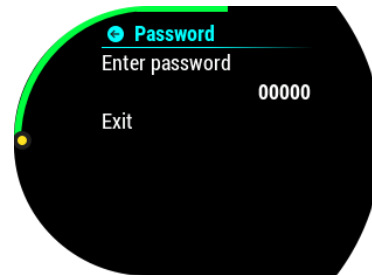

Exit at the top.

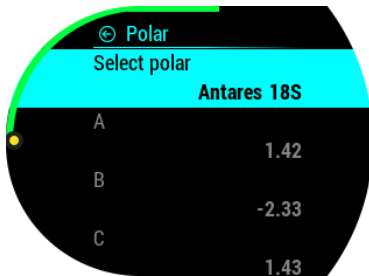

Value can't be changed (grey lettering).

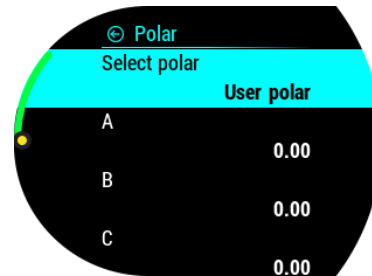

Value can be changed (white lettering).

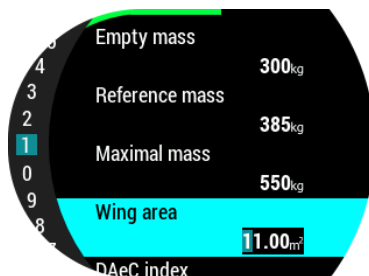

Grey rectangle indicates the character which is being edited.

Edit character with rotary switch.

PART FOUR – SOFTWARE

4 Main pages

Initial setup

After power on is performed, the Initial setup appears. This screen is used for input of basic information, which usually change on a daily level.

- Select pilot (offers the selection of different user created pilot profiles)
- Set elevation (set the elevation of your current location)
- Set QNH (set the current QNH pressure)

If used in LX Zeus configuration, all these settings are done on LX Zeus and this screen is not visible on LX Eos.

All information is provided by turning the push/rotary knob. By pressing enter, the current value is selected and the next instance is shown.



Structure of main pages

To switch between main pages use left/right rotation of rotary switch. Complete structure of main can be seen below.

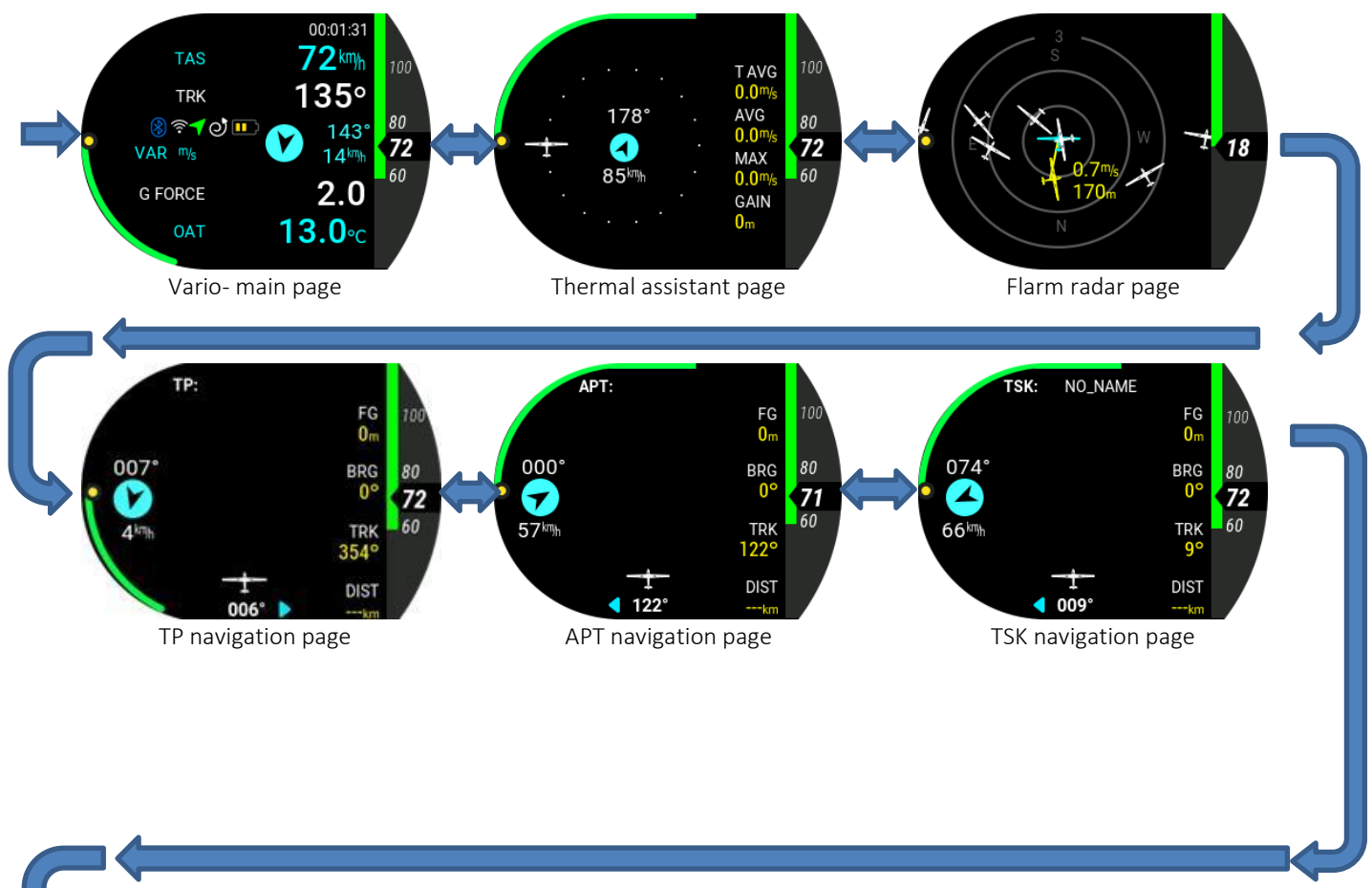

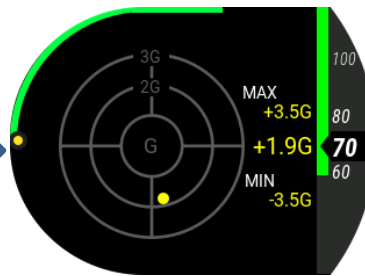

G – force page

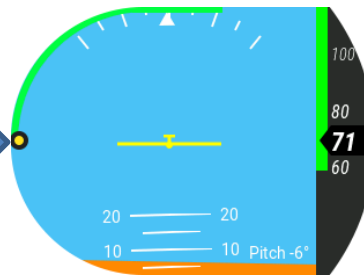

AHRS page **

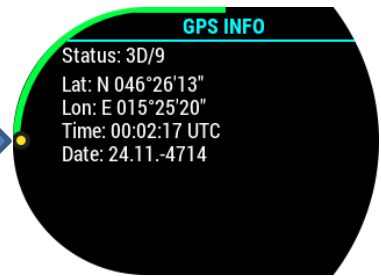

GPS info page



Logbook page

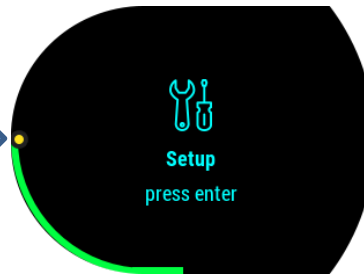

Setup page*

* When used as a part of an Eos – Zeus system, not all options are present.

** Only when AHRS module is detected on CAN bus.

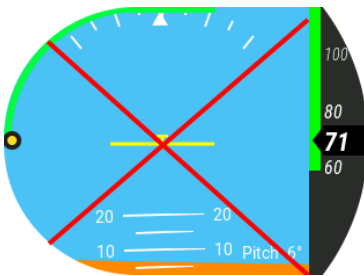

A **red cross** across a page is a standard aviation notification, which indicates that this page is either not available or not working for some reason. On navigational pages, it is usually due to bad GPS connection and on AHRS page, it is indicating that you do not have an AHRS unit connected to your Era. Connecting the missing module or antenna, or allowing the antenna to get a GPS connection will eliminate this symbol. Pages that are not used can be hidden, as explained in section 4.11.12.

4.1 Vario page

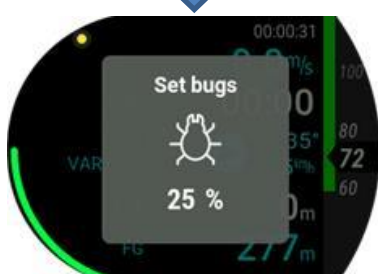

The Vario page is used for displaying a wide spectre of flight-relevant information.

There are four indicator fields available on the vario page when in thermal mode, and another while in SC mode. Two are above the middle row and two below.

All of them (apart from the middle row) can be set to user preferences.

In the middle row, different status icons are shown:

- **Main battery indicator** (outline of symbol is white):
 - 3 green bars – more than 12.0V
 - 2 yellow bars – more than 10.8V
 - 1 red bar – less than 10.8V
- **Backup battery indicator** (outline of symbol is red):
 - 3 green bars – more than 80% left
 - 2 yellow bars – between 20% and 80% left
 - 1 red bar – less than 20% left
- **SC/Thermal icon:**
 - Straight arrow – SC mode
 - Spiral arrow – thermal mode
- **GPS status:**
 - Green arrow – GPS ok (3D)
 - Red arrow – GPS bad
- **Bluetooth icon:**
 - Is visible when Bluetooth connection is active
- **Flarm icon:**
 - Is visible when Flarm is detected on system
- Green arch is SC bar which will move according to MacCready setting, IAS and status of airmass around the plane
- Wind is shown with three parameters:
 - o Wind arrow shows wind direction relative to the aircraft
 - o The upper number (on the right side of the wind arrow) is showing wind direction
 - o Below the wind direction the wind speed is shown with the adjacent unit
- Below the GPS signal indicator, one of the following is shown, informing the pilot what is the mechanical needle currently indicating:
 - o VAR – vario
 - o NET – Netto
 - o SC – Speed command
 - o REL – Relative
 - o G - Force

Pressing enter whilst on the Vario page will open a quick input window, allowing the pilot to quickly change Volume, MacCready, Ballast, Bugs, QNH pressure and brightness level.

Configuration with LX Joy:

When LX Joy is connected to LX Eos 80 in standalone configuration, up/down keys can be used to change the volume and left/right controls for scrolling through the pages. Pushing the centre button on the LX Joy opens a pop up window, used for entering Volume, MacCready, Ballast, Bugs and QNH.

4.2 Thermal assistant page

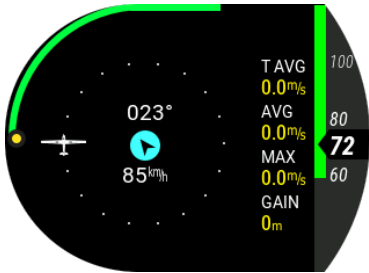

Thermal assistant page is used to help the pilot get a better understanding his current thermal. The thermal itself is represented with different size and colour dots.

Default colour scheme:

White coloured dots show maximum climb detected in last turn. Dot thickness represents strength of climb/sink. Red dots represent climb. Blue dots represent sink.

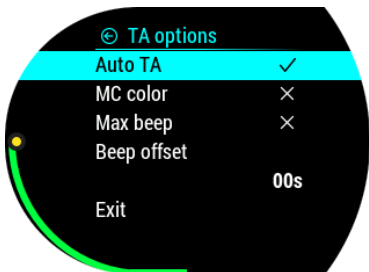

MC colour scheme:

White coloured dots show maximum climb detected in last turn. Dot thickness represents strength of climb. Red dots represent climb which is stronger than 1.2*MC setting. Yellow dots represent climb in range of 0.8*MC and 1.2*MC setting. Blue dots represent climb less than 0.8*MC setting.

If MC setting is less than 0.5m/s, default colour scheme is used!

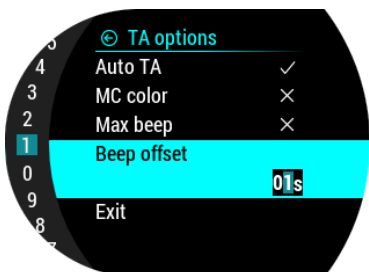

In the middle of the TA circle, wind is shown as a blue arrow with numerical indication for direction and speed. Wind arrow is track up orientated.

Other marks on this page:

- AVG: Integrator value of vario
- M: Maximum value in thermal – white dot
- T AVG: Average of thermal from start of circling until “now”
- GAIN: Altitude gain from start of circling until “now”

To access TA setup, press enter on this page.

Auto TA: It is possible to enable automatic switch to thermal assistant from any other page when circling is detected.

Max. beep: Position of max thermal (white dot) can be reported as a beep. If thermal beep is enabled, LX Eos will generate beep always when you are at position of maximum climb (white dot).

Beep offset: Maximum thermal is announced with beep sound if max beep is enabled. Set beep offset in second here. Beep will be generated before you reach maximum thermal.

4.3 Flarm radar page

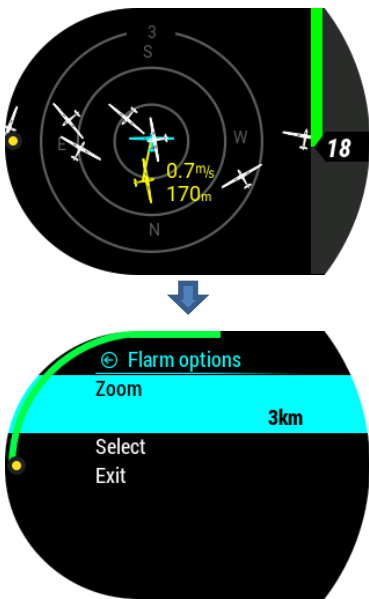

The graphic display is divided into 2 or 3 circles (depends on zoom setting). Last circle represents zoom distance. The white glider symbol is always positioned in the middle of the screen

Near gliders are displayed as yellow. All gliders located in radio range will be shown simultaneously on the display.

ADSB object detected will be shown as green triangle pointing to its tracking direction.

Non-directional objects are represented as red circle, which represents relative distance from plane.

Current zoom is displayed in the top part of the largest circle. Relative altitude and current vario of a selected Flarm object is shown in yellow, next to the object itself.

The graphic display orientation is always track up. To improve orientation, N, E, W and S are added to the display.

Note!

Gliders presented as a dot on the screen, are gliders where pilots have intentionally activated the PRIVACY mode on their Flarm unit. Gliders in

privacy mode send limited data strings and can't be visualized completely. However, all warnings will appear regardless of privacy mode.

To access Flarm radar option, press enter on this page.

Configuration with LX Joy:

When LX Joy is connected to LX Eos standalone configuration, up/down keys will change zoom settings on Flarm radar page. Pushing the centre button on the LX Joy opens a new page, used for setting Zoom level and selecting a Flarm object. Please note that volume can't be set on this page.

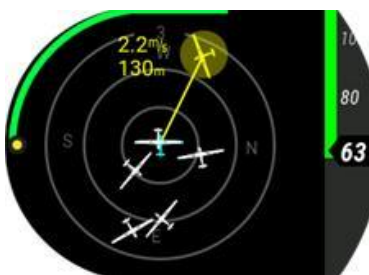

4.3.1 Flarm select

To select new Flarm object, press enter on Flarm radar page and use "Select" option. Yellow opaque circle will be visible around the selected Flarm object, indicating that you are in selection mode.

Use rotary switch to select new one.

Pressing enter will finish select option and Flarm radar will be active again.

4.3.2 Flarm warning

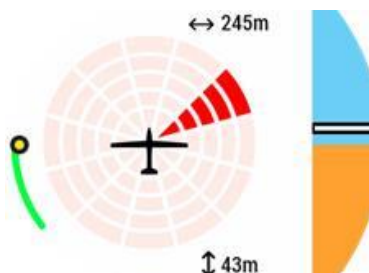

When Flarm warning is detected, Eos will show Flarm warning page with direction, above/bellow indicator and numerical information for distance and relative altitude.

Flarm warning setting:

- enabled, this page will override any Eos menu / page
- disabled, then this page will be seen only on Flarm radar page

4.4TP navigation page

In order to use this page to its maximum extent, the user should first import turnpoint, and airfield files. For more information on this subject, please refer to Setup/SD Card/Load TP. If LX Eos 80 is used in LX Zeus configuration, TP database selected under TP/Task/Eos list on LX Zeus is automatically transferred (unlimited number of TP's). TP is displayed as a white dot with a "W" written inside (Waypoint). Navigation is always "track up".

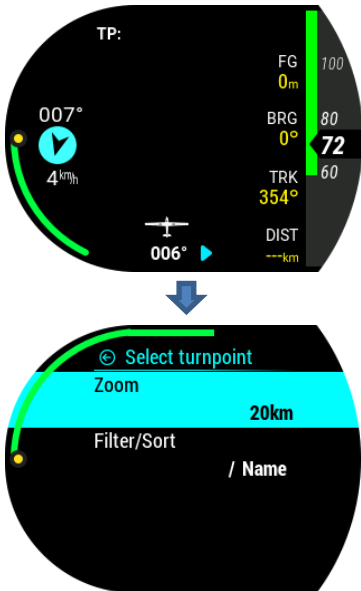

On the top of this page the name of the selected turnpoint is written. On the right side of the screen, next to the IAS bar, Final glide (FG), Bearing (BG), Track (TRK) and Distance (DIST) to the selected point are written.

Below the plane icon, a steering symbol will inform the pilot for how many degrees (°) does he need to correct his track in order to fly towards the selected turnpoint.

In the left part of the screen, standard wind information can be read.

The Arrow shows the winds course in regards to the glider, the degrees it's direction from the North and the speed is shown below.

Pressing the enter button whilst on TP page will open a TP settings menu. This menu can be used for setting the Zoom level, as well as selecting the desired point.

The desired point can be chosen either by scrolling to it, or by using a filter.

Three different filters are available for narrowing down your search: Name, Code and Distance. After confirming the desired filter, a filtered list will appear.

These options are valid only when used without a Zeus. Otherwise, Zeus' turnpoint selection shall be used. Selected point is saved after power reset.

Configuration with LX Joy:

When LX Joy is connected to LX Eos 80 in standalone configuration, up/down keys will change zoom settings on TP page and left/right will sweep between pages. Pushing the centre button will act as Enter.

4.5 Airport navigation page

In order to use this page to its maximum extent, the user should first import, airspace and airfield files. For more information on this subject, please refer to Setup/SD Card/Load TP. If LX Eos 80 is used in LX Zeus configuration, APT database selected under TP/Task/Eos list on LX Zeus is automatically (unlimited number of APT's). TP is displayed as a white dot with a "W" written inside (Waypoint). Navigation is always "track up".

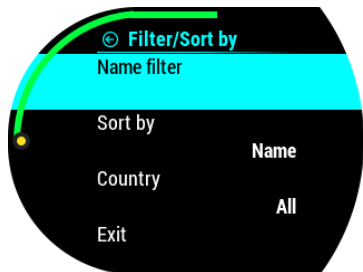

On the top of this page the name of the selected turnpoint is written. On the right side of the screen, next to the IAS bar, Final glide (FG), Bearing (BG), Track (TRK) and Distance (DIST) to the selected point are written.

Below the plane icon, a steering symbol will inform the pilot for how many degrees (°) does he need to correct his track in order to fly towards the selected turnpoint.

In the left part of the screen, standard wind information can be read. The Arrow shows the winds course in regards to the glider, the degrees it's direction from the North and the speed is shown below.

Pressing the enter button whilst on TP page will open a TP settings menu. This menu can be used for setting the Zoom level, as well as selecting the desired point.

The desired point can be chosen either by scrolling to it, or by using a filter. Three different filters are available for narrowing down your search: Name, Code and Distance. After confirming the desired filter, a

filtered list will appear.

These options are valid only when used without a Zeus. Otherwise, Zeus' turnpoint selection shall be used. Selected point is saved after power reset.

Configuration with LX Joy:

When LX Joy is connected to LX Eos 80 in standalone configuration, up/down keys will change zoom settings on TP page and left/right will sweep between pages. Pushing the centre button will act as Enter.

4.6 Task navigation page

This page should be used for navigational purposes, when flying tasks.

There are two ways of entering a task. Either by selecting a .CUP file, which contains a task inside, or by creating it by hand.

or more information on how to import TPs please refer to section Setup/SD Card/Load TP. Navigated task TP is displayed as observation zone and a white line from zone to plane is showing direction in which the pilot should fly. White line from centre of observation zone will show next leg of task. Navigation is always “track up”.

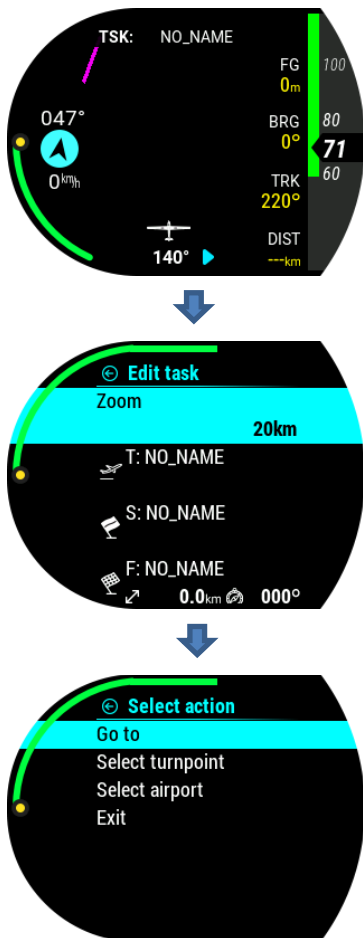

On the top of this page pilot can find the name of navigated TP.

Under the name, final glide to the end of the task is displayed.

Navboxes show final glide (FG), bearing (BRG), track (TRK) and distance (DIST) to the navigated point.

Under the plane, steering symbol information will give pilot information for how many degrees (°) does he need to correct his track to fly directly to the point.

Configuration with LX Joy:

When LX Joy is connected to LX Eos 80 in standalone configuration, up/down keys will change zoom settings on TSK page and left/right will sweep between pages. Pushing the centre button will act as Enter and open TSK Setup.

Pressing enter, “TSK SETUP” is activated where a task can be created or edited. Additional TP’s can be added, removed, zones changed etc.

Additional options will be offered to the pilot only in standalone configuration or in backup mode. In LX Zeus configuration, TSK TP options can be set on LX Zeus, and LX Eos 80 will receive task information from the Zeus.

Additional options:

- Go to: Navigate to that point on task
- Select turnpoint
- Select airport
- Insert turnpoint
- Insert airport
- Edit zone
- Delete

Observation zone

If auto next option is enabled, next TP is automatically selected, when pilot reaches TP zone.

User can change A1, R1, A2, R2, zone type, A21 and auto next option.

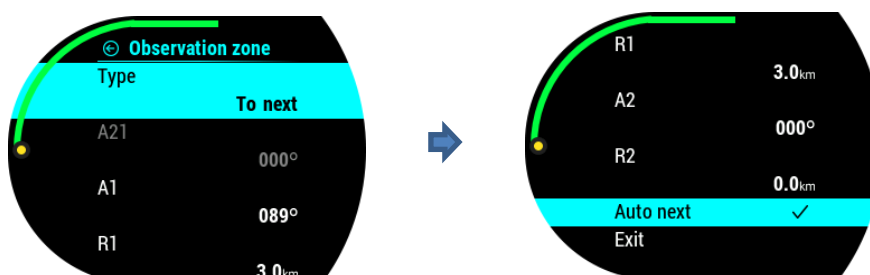

4.7G-Force page

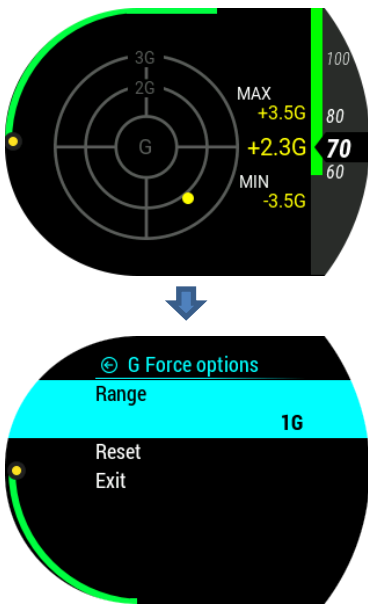

The G-force page consists out of a circular scale representing the different values of acceleration and a yellow dot, which moves in accordance with the current force resultant. On the right side of the display, three values can be seen. The top represents the maximum detected, the bottom represents the minimal detected (or maximum negative force) and the middle one represents the current G-force. These values can be cleared anytime during the flight in G-FORCE menu. Range setting is presented with small text within the lines of the G-force scale. This range can also be set in G-FORCE menu.

To enter G-FORCE menu, press enter on G-force page.

- Set range of G-force scale
- Clear min/max values

Configuration with LX Joy:

When LX Joy is connected to LX Eos standalone configuration, up/down keys will change range settings on G-force page. Pushing the centre button on the LX Joy opens a new page, used for setting range level and **Please note that volume can't be set on this page.**

4.8 GPS info page

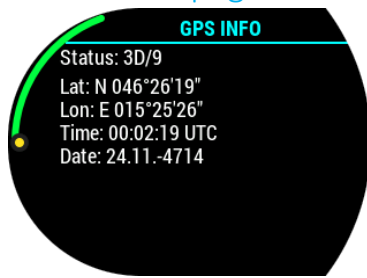

Basic GPS information is shown here.

- Status: 3D/6 – 3D GPS, 6 satellites found
- Status: Last fix – currently no satellites are found, last known location is displayed as Lat, Lon
- Lat: N or S – latitude, North or West
- Lon: W or E – longitude, East or South
- Time: only UTC time
- Date: current date

4.9 Logbook / statistic page

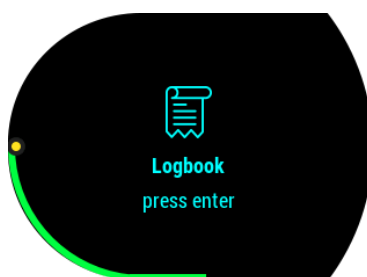

4.9.1 Logbook

On the ground (flight recorder is not running) logbook can be accessed by pressing enter on logbook page.

Pilot can copy take-off / landing time to personal logbook and transfer flight to external SD card for OLC upload.

Last 50 flights are listed. Any older flights will be erased from logbook list. Press enter on selected flight to open flight info, where “copy” option is available to transfer flight to external SD card.

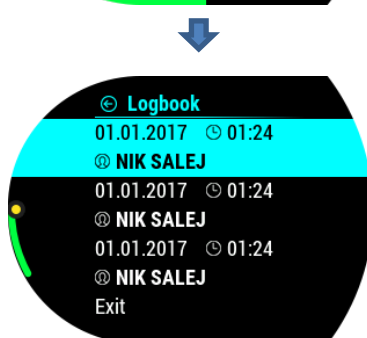

Flight is copied to external SD card to LX/FLIGHT folder

After flight has been transferred, “Copy OK” is displayed. Press enter to continue.

In LX Zeus configuration, flight can be downloaded from LX Zeus logbook page to LX Zeus USB key.

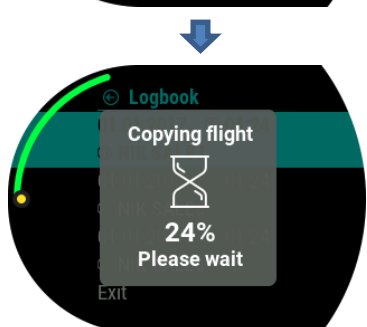

4.10 Statistic



During flight, statistic of the flight is shown on statistic page. Take-off and duration time are displayed on top with barographic altitude for the last hour.

Pressing enter on this page, will offer the pilot an option, to end flight immediately on demand.



If "Yes" option is selected, message "Calculating security" will be visible. Selecting "No" will do nothing and statistic page will be visible again.



After pilot has landed, flight recorder will start 5 min countdown, before flight will be automatically finished. This page will be shown automatically after 10 second of countdown to alert pilot that flight will end after 5 min. Pilot can wait until countdown or press enter to end flight immediately.

4.11 Setup

Under setup, pilot can set all parameters of the unit. Setup page can be accessed only if LX Eos is used as standalone unit. When connected to LX Zeus, all information is automatically synchronised between LX Zeus and LX Eos. In case of backup operation with LX Zeus, Setup will appear automatically.

4.11.1 Pilot

All entered data (except for weight), will be written to flight recorder as pilot declaration info.



Pilot can either select pilot that is already saved in the database or select "EMPTY" to create a new pilot. If pilot is already saved, name initial and surname are shown. Pilot name or "EMPTY" is automatically shown in the second line. Code input will be required if selected user has his profile protected with user code.

- Pilot name: edit the name of the pilot.

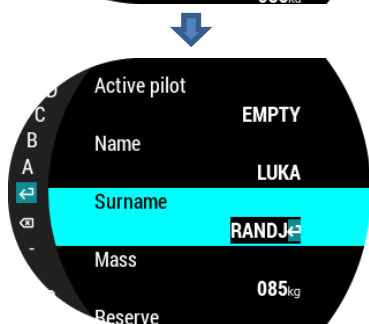

- Pilot surname: edit the surname of the pilot.

Pilot's weight is added to the whole weight of the plane to calculate actual wing load factor.

- Weight: edit the weight of the pilot.

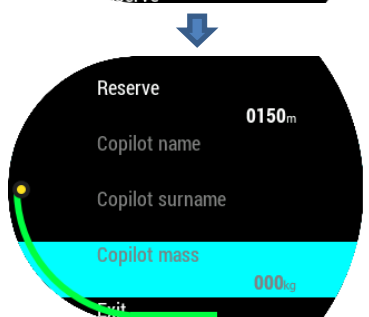

Co-pilot's data is visible in-flight declaration (IGC file).

- Copilot name: edit the name of copilot.
- Copilot surname: edit the surname of copilot.

Co-pilot's weight is added to the whole weight of the plane.

- Copilot weight: edit the weight of copilot.

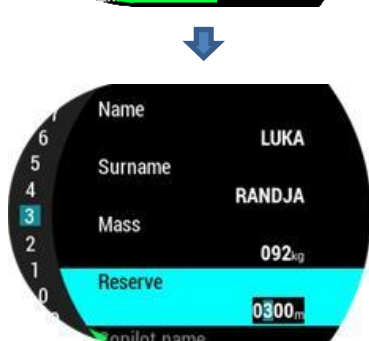

Pilot should set actual QNH and elevation of the airport where he will take-off on initial setup screen. After change of QNH during flight, pilot can change altitude information to which final glide will calculate. If QNH is changed on the ground, altitude will not be corrected and will still be the same as set on initial setup.

Reserve is the safety arrival altitude that instrument adds to the required final glide altitude so that the glider arrives over navigated destination with selected reserved altitude.

4.11.2 Vario/SC

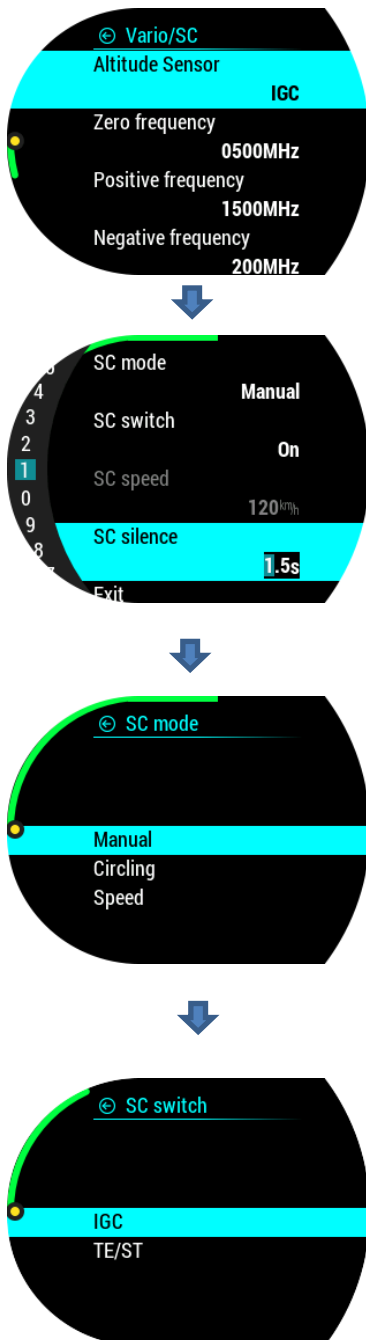

In this menu pilot can set vario settings:

- **Altitude sensor** allows the user to choose which sensor will provide altitude information to the instrument. At lower altitudes, the pressure sensor is more accurate and effective. At very high altitudes, measurement error rises because of the nature of the pressure sensor. For such high altitudes, the IGC (GPS) sensor is recommended.
- **Zero frequency** is a frequency generated at 0 m/s
- **Positive frequency** is frequency at maximum climb shown on scale (depends on range setting)
- **Negative frequency** is frequency at maximum sink shown on scale (depends on range setting)
- **Audio test** will generate vario movement from +6m/s to -6m/s so user can check audio setting in this range
- **Range** is the scale for vario. Three options are available – 2.5, 5 and 10 m/s (5, 10 and 20 kts, according to user selected units).
- **Filter** defines the dynamics of the vario needle and sound. The smaller the time the faster is response and vice versa
- **TE Level** – look for the explanation below
- **Integration time** defines integration period for averaging the vario data in seconds
- **SC mode** allows the pilot to choose between different methods for automatic switching, or manual SC switch
- **SC switch** mode for different types of switches
- **SC speed** is possible and should be set only when “Speed” has been chosen under “SC mode”
- **SC silence** mutes the range around 0 – for instance, 1.5m/s means that all values from -1.5m/s to +1.5m/s will be muted.

TE Level is the level of electronic TE (total energy) compensation for variometer. Selection of electronic compensation method is done after selection of TE level. 0% means total energy compensation using a TE probe. After an input of a percentage, which is more than zero the special software routines will be activated and will provide an electronic compensation process.

TE compensation can be fine-tuned during flight with the following procedure. It is essential that this is only done in smooth air; it is not possible to tune the TE accurately when there is thermal activity.

- Select 100 % TE level.
- Accelerate up to approximately 160 km/h (75 kts) and keep the speed stable for a few seconds.
- Gently reduce the speed to 80 km/h (45 kts).

Observe the vario indicator during the maneuver. At 160 km/h (75 Knots) the vario will indicate about -2 m/s (-4 kts). During the speed reduction, the vario should move towards zero and should never exceed zero (slightly positive indications are acceptable). If the vario shows a climb, then the compensation is too low, increase the TE level; and vice versa. Repeat this procedure and make further adjustments if necessary.

SC mode:

- Manual: pilot will activate the SC mode with push of an external button. Activate settings of SC button can be set under SC Switch option.
- Speed: SC mode will be automatically activated when the "SC speed" is exceeded.
- Circling: SC mode will be automatically activated when LX Eos detects that you left thermal, and will automatically switch back to vario mode when you enter next thermal.

With the use of **external switch**, it is possible to switch between SC and vario manually, if manual SC mode is selected.

- SC Switch:
 - ON means that closing of the switch will cause SC mode.
 - OFF means that closing of the switch will select vario mode.
 - Toggle each press of the button will change between SC and vario mode.
- SC Speed setting is the speed value at which the SC Mode is activated if SC mode is set to speed.
- SC Silence defines no audio area around zero in SC mode.

4.11.3 Polar

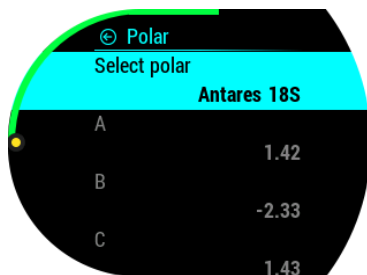

Nearly all glider polars are stored in the LX Eos memory. It is also possible to create a user defined polar. Not editable data is in grey.

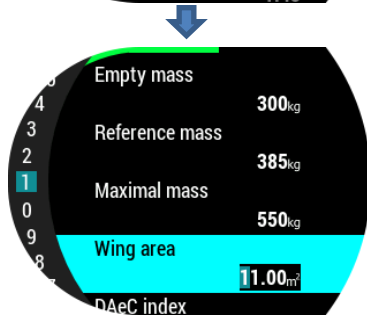

It is always possible to edit empty weight of the glider.

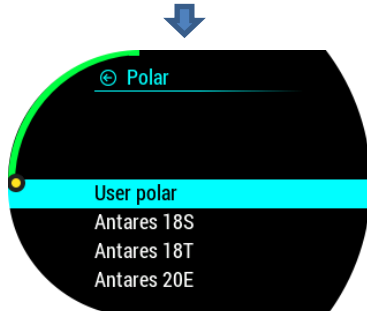

To create custom polars find "USER" in first line. When "USER" is selected all polar data will turn to white so the pilot can edit them. Reference mass is to be used only with user defined polars. The reference mass represents the mass, at which the input polar parameters were measured.

4.11.4 Units

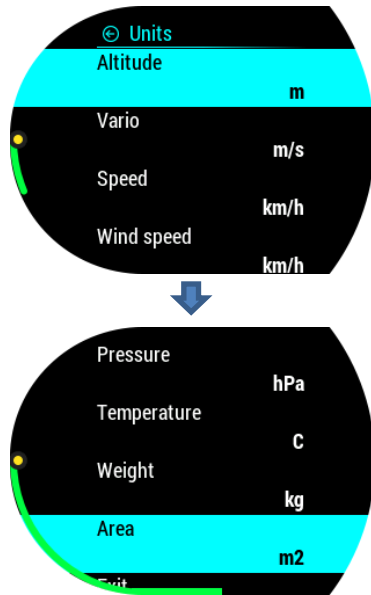

Pilot can set units for:

- Vario (m/s, kts)
- Altitude (m, ft)
- Distance (km, nm, mi)
- Speed (km/h, mph, kts)
- Wind (km/h, mph, kts, m/s)

- Pressure (mbar, inHg)
- Temperature (°C, °F)
- Weight (kg, lb)
- Area (m², ft²)

4.11.5 Indicators

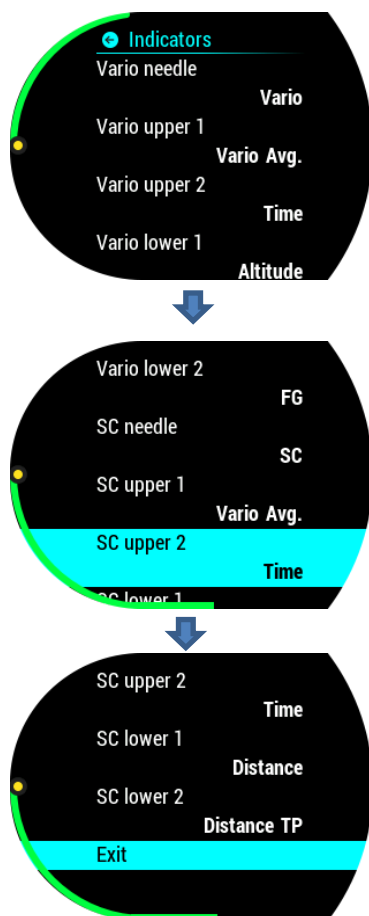

Pilot can select needle functions in vario and SC mode.

- Vario: vertical speed of the plane
- SC:
 - needle on 0, optimal flying condition (MC)
 - needle is above 0, slow down
 - needle is below 0, speed up
- Netto: Shows air mass vertical movement at that moment
- Relative: Shows vario if pilot would start circling on that point
- G-force: Shows current G-force

Vario/SC lower 2 represents the lower most numerical display indication in Vario/SC mode on vario page. Vario/SC lower 1 represents the one above Vario/SC lower 2.

In all cases the pilot can choose from:

- **Empty:** Leaves the indicator window empty
- **Vario Avg.:** Average vario value in a specific window (chosen when setting Integration time)
- **Time:** UTC time
- **Flight time**
- **Leg time:** When connected to Zeus it shows actual TSK leg time
- **Altitude:** Altitude according to QNH data inserted
- **Distance:** When connected to Zeus it shows distance on active page (APT, TP or TSK)
- **Distance TP:** Distance to turn point selected on TP page
- **Distance TSK:** Distance to next turn point selected on TSK page
- **FG:** When connected to Zeus it shows final glide on active page (APT, TP or TSK)
- **FG TP:** Final glide to turn point selected on TP page
- **FG TSK:** Final glide to next turn point selected on TSK page
- **TAS:** True Air Speed
- **IAS:** Indicated Air Speed
- **Alt. QNH-ft:** QNH altitude in feet
- **Flight level**
- **OAT:** Outside Air Temperature
- **Vario netto:** Netto variometer
- **Vario relative:** Relative variometer
- **IGC Altitude**
- **SpeedToFly:** Speed to fly at given MC setting and air mass around the plane
- **G-force:** Current force resultant
- **Flap:** Shows the current flap position
- **Rec. Flap:** Shows recommended flap position
- **TRK:** Current Track
- **Ground speed**
- **Distance APT:** Distance to chosen APT
- **FG APT:** Final glide on chosen APT

4.11.6 Logger

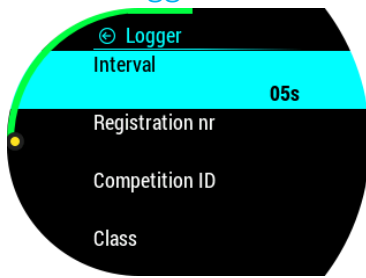

The pilot can set recording interval, registration number of the plane, competition id, competition class and event settings. Input data is then seen as declaration in every IGC flight file.

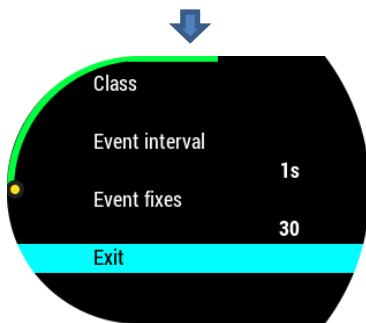

Set number of event fixes and event record interval. Event can only be activated when in flight mode, either by going to GPS info page and pressing enter, or using inputs.

4.11.7 Warnings

Warnings are used to inform pilot that some flight related data is outside margins. When warning state is detected by LX Eos, pilot will get red warning message box with description of what is outside margins.

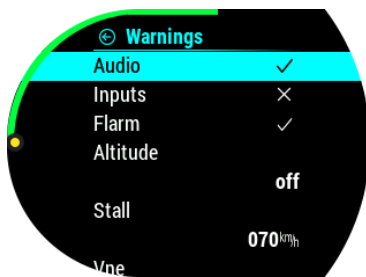

Pilot can enable (box is checked) audio warnings and Flarm warnings.

- Audio: if disabled, voice warning will not be generated – only visual warning message box
- Inputs: Must be turned on to enable input port warnings such as airbrakes, gear etc.
- Flarm: Flarm warning page will be seen only on Flarm radar page if this option is disabled, otherwise it will override any Eos page/menu when warning is detected

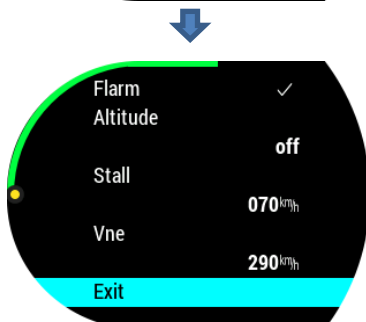

- Altitude warning: warning when flying over selected altitude
- Stall: warning when the glider speed is lower than stall speed
- Vne: warning when speed exceeds Vne speed

4.11.8 Voice



Pilot can set the voice volume of the device and mixer settings. The percentage of mixer means how much voice is mixed with vario beep. Low percentage means lower voice to vario beep ratio and higher percentage means higher voice to vario beep ratio.

Enabling Flarm traffic option will generate voice announcement when new Flarm object is detected.

Enabling Flarm warning option will generate voice warning when Flarm collision warning is detected.

Enabling Flarm obstacle option will generate voice warning when obstacle from Flarm database is detected in front of the plane.

With Flarm h. distance setting, user can enable/disable horizontal voice information for Flarm traffic.

With Flarm v. distance setting, user can enable/disable vertical voice information for Flarm traffic.

4.11.9 Transfer

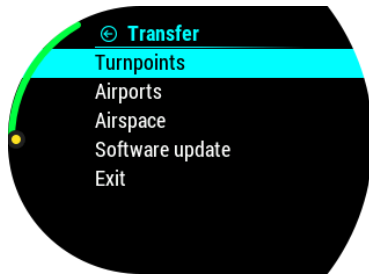

The transfer page is used for transferring turnpoint and task files (.cup), airport files (.af), airspace files (.cub) and software updates (.lxu). It is also used for selecting active files and deleting old files.

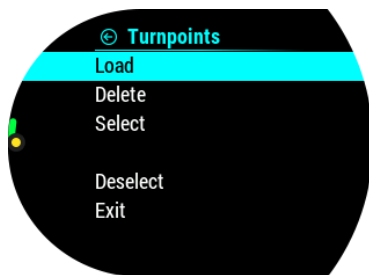

Turnpoints

After selecting “Turnpoints” option, multiple options are shown:

- Load is used for uploading files from microSD to device
- Delete is used for erasing files from the device
- Select is used for selecting the active file
- Deselect is used for deselecting the file

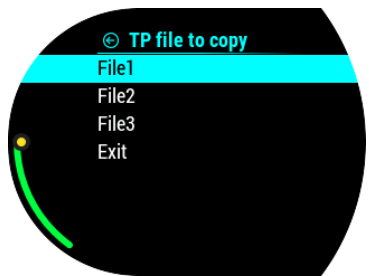

A list of .cup files (up to 20) found in the root of external microSD card will be listed under Load Turnpoint.

Select file from which you wish to import TPs and tasks to internal database.

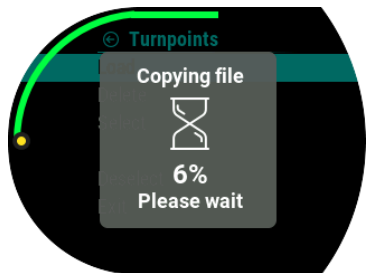

After importing, the process can take from 5 sec. up to 10 min (depends of TP number and alphabetical sort inside CUP file). Number of TPs is not limited but we recommend to use CUP file with up to 6000 points. Name of every TP will be shortened to max 11 characters after import.

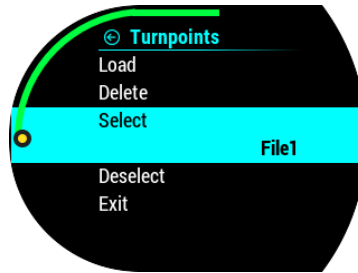

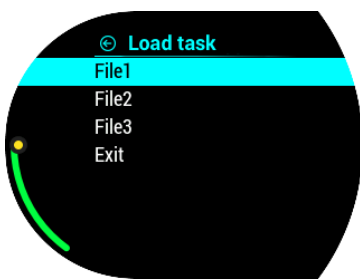

Load TSK

After selecting “Load TSK” option, list of all CUP files (up to 20) found on external SD card in LX/TP folder will be listed here. Select file from which you wish to import TSK to internal memory.

After selecting file from which you wish to import task, first 20 tasks found in the file will be listed. Select the task you wish to import and press enter. Observation zones will be loaded as well if defined in file, else standard FAI zones are used.

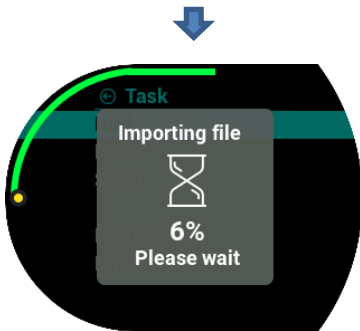

Warning: Due to internal task limitations, only first 18 points of selected task will be loaded from file.

Wait until load is finished.

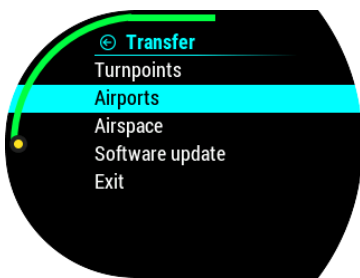

Airports

After selecting “Airports” option, multiple options are shown:

- Load is used for uploading files from microSD to device
- Delete is used for erasing files from the device
- Select is used for selecting the active file
- Deselect is used for deselecting the file

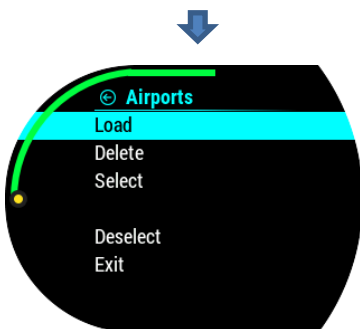

A list of all .af files (up to 20) found in the root of external microSD card will be listed under Load Airports.

Select the file from which you wish to import APTs to internal database. .af file is commonly used file for transferring APTs.

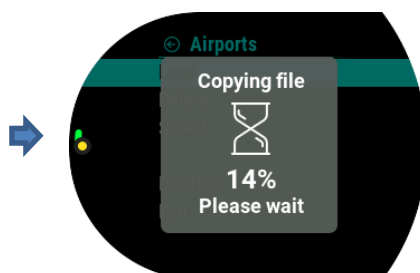
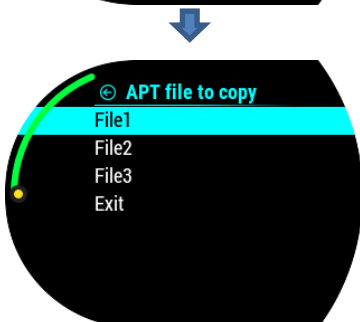

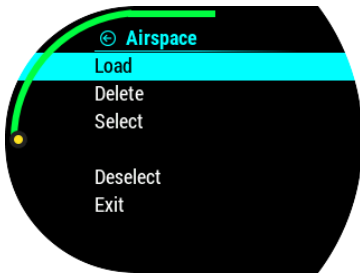

Airspace

A list of all .cub files (up to 20) found in the root of external microSD card will be listed under Load Airspace.

Select the file from which you wish to import Airspace data to internal database.

.cub file is commonly used file for transferring Airspace data.

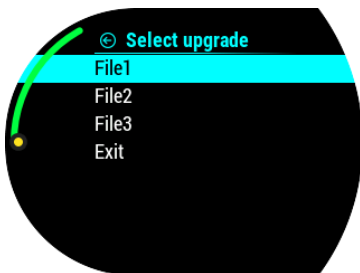
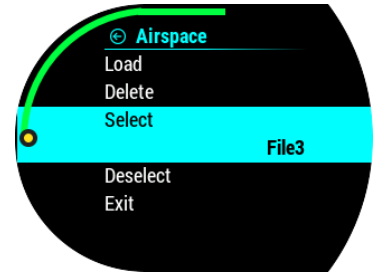
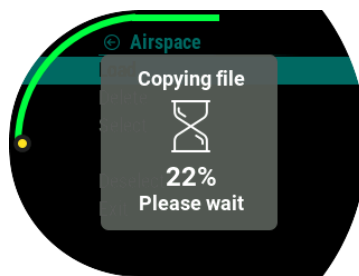
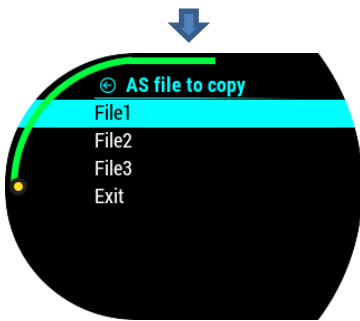

Software update

Before update, the user should request update code at: update-service@lxnavigation.si In the email request, user should provide serial number of the unit and version to which he wishes to update to.

User should copy the new version to the **root** of external microSD card, then insert it into the LX Eos and use "Software update" option to make an update of the unit. After selecting "Software update", list of all version (*.lxu) files will be listed. Pilot should select version, which he wishes to update to.



For the first versions (below 1.0) the update code is commonly 00000.

After code is entered, LX Eos will report error, if code is not correct or start update. Update can take up to 4 min. Device will automatically restart after successful update. LX Eos will also update all LX CAN devices connected to the system.

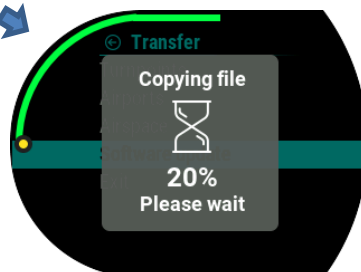

Flarm NET

It is possible to transfer and use Flarm Net object database.

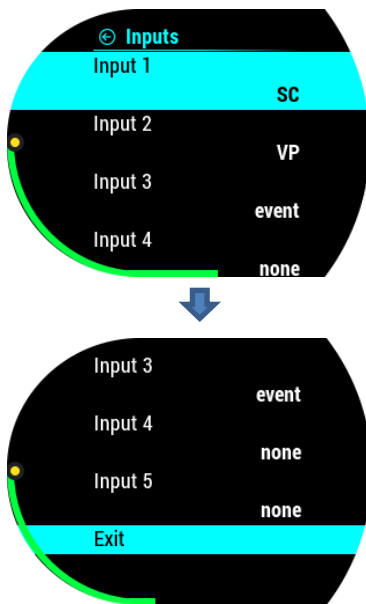

4.11.10 Inputs

LX Eos has a possibility of five different user defined inputs. Each input can be set accordingly. There are seven options to choose from:

- None: nothing is connected to the input
- SC: the device changes mode from vario to SC mode
- VP: (vario priority) the device goes to vario mode no matter in which condition is SC mode
- Event: event in flight recorder is activated and pilot gets a message shown on display
- Gear: If enabled under warnings will generate gear up/down warnings after take-off / before landing
- Airbrakes: if enabled under warnings, will generate airbrakes warning if they are opened during take-off
- Ballast: not yet supported

Inv – invert mode:

Each input has invert option. When invert option is enabled, it will “invert” active state of this input.

Invert option:

- off: input is active when switch is closed
- on: input is active when switch is opened

If two or more inputs are the same, the corresponding action will be made when all of them are active (**active = switch closed or switch open in Inv mode!**).

How to connect switches to external switch interface, please refer to external switch installation section.

Functions of inputs:

- **SC:** LX Eos supports two modes of operation Vario and SC. With SC input, user can change between these two modes.
- **VP:** Vario priority is used when user wants to have vario mode active. VP input has higher priority than SC input!
- **Event:** To trigger pilot event in logger with higher recording interval, this option of input should be selected.
- **Gear:** If any of inputs is selected as gear, gear warning will be announced at next conditions:
 - gear is out 10min after take-off is detected and height is more than 500m above take-off location.
 - gear is not out and altitude is less than 200m in 5km circle of take-off position and flight time is more than 5min.
 - on out landing (if airbrakes are out, elevation less than 600m QFE, distance from take-off more than 5km) and gear is not out.

Airbrakes:

If any of inputs is selected as airbrakes, gear warning will be announced at next conditions:

- airbrake is out during first 10min of flight (take-off / aero tow time).



4.11.11 NMEA

This setup page is used to set which data is being sent to third party unit connected through BT or user port.

The pilot can set baudrate for communication over User port or Flarm port. Pilot can select from: BR4800, BR9600, BR19200, BR38400, BR57600 and BR115200 options.

LX Eos is capable of sending NMEA data to third party units such as PDA or PNA. The data is available on the connector marked as USER and BT port. Five data strings are offered.

Selected (checked box) NMEA data will be sent over User port and Bluetooth.

- GPGGA – Global Positioning System 3D-Fix Data
- GPRMC – Recommended Minimum Specific GPS/TRANSIT Data
- GPRMB – TP navigation info
- LXWPx – sentences contain pressure and altitude information in addition to IAS data
- PFLAx – Flarm traffic info. Data must be enabled, if Flarm data is required on a PDA
- Radio – Enable this option when radio is connected to user port. Control over the radio is only possible in configuration with LX Zeus.
- Transponder – If enabled, bauderate on Flarm port will go to 9600 and GPS data will be transmitted on Flarm port
- **When Radio option is enabled all other outputs on User port are disabled, but are still present on BT port.**

4.11.12 Pages

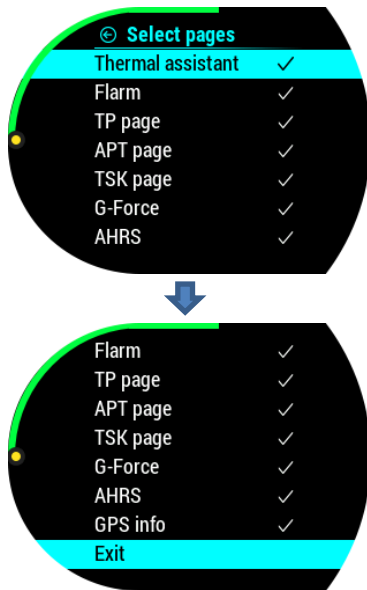

The pilot can select which main pages are active. Page is active when box is checked. There are eight main pages available:

- Thermal assistant
- Flarm
- TP page (turnpoint)
- APT page (airport)
- TSK page (task)
- G-force
- AHRS (artificial horizon)
- GPS info

4.11.13 Password

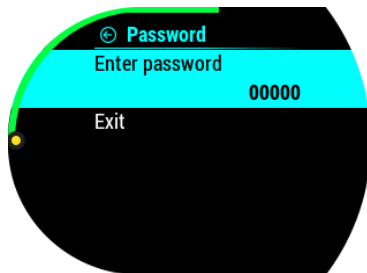

To access some options, password is required. Available passwords are:

- 46486: sets LX Eos to factory settings.
- 99999: clears all flights from flight recorder – logbook is empty.
- 28346: audio player (will play any wav file 8bit 16kHz mono from root of external SD card).
- 66666: clears actual task
- 55555: clears internal TP database

4.11.14 Info

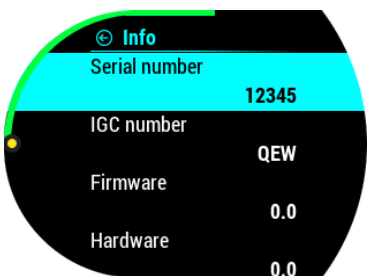

LX Eos info page with displayed information:

- Serial number
- IGC serial number
- Firmware version
- Hardware version

4.11.15 Shutdown

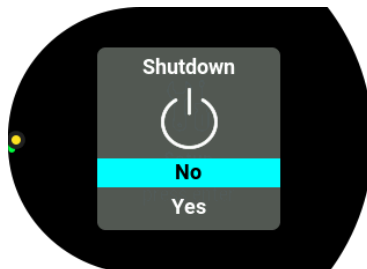

When shutdown option is selected, this screen will be shown to confirm that you wish to shutdown the device. Selecting “No” will return you back to setup menu, while selecting “Yes” will turn off the unit.

If shutdown option is selected during flight, this message will be shown. Please finish the flight first and then turn it off!

PART FIVE – CONNECTIVITY

5 Wi-Fi/Bluetooth module

LX Eos has an internal Bluetooth 4.0 module which is always on and cannot be turned off. At the back of the unit, there is an SMA connector for external Wi-Fi/Bluetooth antenna, that enables better range.

5.1 Pairing with PNA and Android devices

Perform a search of BT devices on your PNA/PDA/Android device. LX Eos XXXXX, where XXXXX represents the serial number of the unit, will be visible on the device list, when in range and turned on. Pair code will be requested to start communication with PDA/PNA/Android device and Lx Eos. Enter pair code: **1234**

After successful connection, Bluetooth icon is visible on main vario page.

5.2 Supported data transfers

<u>Description</u>	<u>Supported</u>	<u>Remark</u>
GPGGA	Yes	If enabled in NMEA setting
GPRMC	Yes	If enabled in NMEA setting
GPRMB	Yes	If enabled in NMEA setting
LXWPx (LX data)	Yes	If enabled in NMEA setting
PFLAx (Flarm data)	Yes	If enabled in NMEA setting and Flarm is connected to Lx Eos
Declaration from Eos	No	
Declaration to Eos	Yes	
CUP file transfer	No	
Flight transfer	No	

5.3 Usage

Bluetooth communication is designed to be used in double seat gliders, so 2nd seat PDA/PNA can get all the data via BT or when only power cables are provided in glider for PDA/PNA (Club gliders).

6 User port

LX Eos uses User port (RS232 standard) to connect to third party devices such as PDA/PNA (Oudie, Mio,..), radio (KRT2)

Connect any third-party device only with LX Navigation supported cable. Any unsupported cable may damage LX Eos or third-party device beyond repairs. For successful communication, correct BR must be selected under NMEA settings.

Note: For some PDA (for example HP314) it is preferable to set the USER Port at BR115200 or at least at the maximum BR that is supported by the PDA. This can help to avoid communication problems during the declaration from PDA to LX Eos

6.1 Supported data transfers

<u>Description</u>	<u>Supported</u>	<u>Remark</u>
GPGGA	Yes	If enabled in NMEA setting
GPRMC	Yes	If enabled in NMEA setting
GPRMB	Yes	If enabled in NMEA setting
LXWPx (Lx data)	Yes	If enabled in NMEA setting
PFLAx (Flarm data)	Yes	If enabled in NMEA setting and Flarm is connected to Lx Eos
Declaration from Eos	No	
Declaration to Eos	Yes	
CUP file transfer	No	
Flight transfer	No	
Radio	Yes	
Transponder	Yes	

7 SD card

At the back of the unit, there is an RJ11 connector intended for connecting the provided MicroSD card adapter. This microSD card reader should be used for all transfers to and from the Eos.

Additional information

Task transfer

The user can transfer the Task to LX Eos using two ways:

- Via microSD card as explained in chapter 14.9.2 "Load TSK" in relation to TPs and their view zone.
- With a PDA/PNA/Android device connected to User port or via Bluetooth. This way the user can only send the IGC declaration according to FAI rules. They will be transferred to LX Eos the TPs and the view zone of the start line and of the finish line. A standard FAI view zone (90°) will be assigned to all intermediate TPs. The user can later change, if necessary, the view zone directly in Task page of LX Eos.

Flight Recorder Management

The flight recorder doesn't need any special care as it works nearly automatically without pilot assistance. All the pilot should do is to adapt the logger settings, see the Setup page / Logger menu chapter.

Start and Stop of flight recording

The unit will start recording immediately after start conditions are met. Start conditions are based on ground speed and altitude change, so even if the GPS status is bad during take-off, the unit will start recording.

It is recommended to switch the unit on a few minutes before take-off. This will ensure a straight base line of baro trace (IGC regulation). Running time before take-off will not reduce memory space of the flight recorder, due to circular recording before take-off.

After landing the unit will close the flight after approximately 10 minutes at standstill, so it is recommended to keep the unit under power and GPS OK until the Calculating Security message appears on the display. To determine if the flight recorder has closed the flight, go to logbook/statistic page. If the Logbook appears, the recording has finished, if the statistic page appears, the recorder is still active.

Flight evaluation

To check the flight data integrity, use the IGC shell program. IGC shell is an IGC freeware program specially designed to verify the flight record integrity. Use the latest LXN.dll file to validate LX Eos flights. Latest version of LXN.dll is available on <http://www.lxnavigation.com/software/>

IGC file structure

IGC flight record file is text file, meaning the data are simply readable by any text editor.

Example of an IGC flight is printed below:

```

ALXNQ8QFLIGHT:2
HFDTE080115
HFFXA015
HFPLTPILOTINCHARGE:NIK SALEJ
HFCM2CREW2:
HFGTYGLIDERTYPE:LAK19-15
HFGIDGLIDERID:
HFDTM100GPSDATUM:WGS-1984
HFRFWFIRMWAREVERSION:1.00
HFRHWHARDWAREVERSION:1.00
HFFTYFRTYPE:LX Eos 80
HFGPS:uBLOX-LEA-6S,50ch,max50000m
HFPRSPRESSALTSENSOR:INTERSEMA,MS5607,max12000m
HFCIDCOMPETITIONID:
HFCLCOMPETITIONCLASS:
I043638FXA3940SIU4143GSP4446ENL
C110509143109110509000100
C4619767N02003217ESZATYMAZ
C4622930N02015629ETSKSTART
C4619767N02003217ESZATYMAZ
C4619767N02003217ESZATYMAZ
F0931560231110413071732232025
LLXNORIGIN0926594619153N02003303E
B0926594619153N02003303EA0006900091007000
B0927054619153N02003303EA0006800091007000
B0927114619153N02003303EA0006800091007000
B0927174619153N02003303EA0006900093007000
B0927234619153N02003303EA0006800093007000
B0927294619153N02003304EA0006900093007000
B0927354619153N02003304EA0007000093007000
B0927414619153N02003304EA0007000093007000
B0927474619152N02003304EA0007000091007000
B0927534619153N02003304EA0006900091007000
B0927594619152N02003304EA0006800091007000
B0928054619152N02003304EA0006800091007000
B0928114619152N02003304EA0006800093007000
B0928174619153N02003304EA0006800091007000
G33069178E3C800E8CE815DD7F0D6968983E2BC0F44C3DC20645F06CC9F78E84
GAF5B28F33E76C8DC5C105CB2B168472106BA50860B3DC93F72D9439C9B371975
G43221B
  
```

Recorder Sn. and flight number

Date of the flight

ENL enabled

Flight declaration data as C record

B records as position records

G record is a digital signature, ensures data integrity and is always the last record of the flight

Barograph trace check (calibration)

Each flight recorder should be periodically checked to verify that the built-in pressure sensor is still in limits. The procedure is extremely simple and takes only minutes to finish. The most important action is setting the Rec. interval in Logger Setup to 1 second otherwise the trace will not be uniform. The procedure is as follows:

- Turn the unit on and put it into the pressure chamber.
- Set QNH 1013mBar conditions in the chamber.
- Apply a pressure jump to start recording.
- Climb apr. 4m/s and make a stop for apr. 30 seconds every 1000 m.
- After reaching 8000m sink apr. 4 m/s and make stops after every 1000m.
- After reaching zero open the chamber and wait for 1 min then manually end flight.
- Download the "flight" from the logbook.
- Return Rec. Interval setting to previous value.
- Print baro trace using your preferred PC program, for instance Lxe (available on www.lxnavigation.com).

PART FIVE – FLYING WITH EOS

To get the best out of the LX Eos, it is important that some preparation is done prior to the flight – trying to configure the instrument or set up a task while flying the glider may spoil your whole day! Pre-flight preparation will ensure that the flight will be both successful and enjoyable.

Flight preparation on ground

- Check if you have desired TP, APT and Airspace database uploaded.
- Prepare a task.
- Check pilot information (this information is written into the flight declaration)
- Check logger settings

Before take off

- Switch the unit ON at least 3 minutes before take-off (this will ensure sufficient GPS reception and will create a base line of the baro trace).
- Select correct pilot (many settings belongs to pilot) on initial setup or create new.
- Check task if it is correct after using of Task stup.
- The actual task during take-off will be declared in flight recorder automatically.

During flight

The LX Eos HW and SW concept is so far optimized that the pilot doesn't spend too much time to operate the unit during flight. A very significant indication that shows that the unit has changed to flying mode is Logbook replacement with statistics page.

Set QNH

The pilot should input actual QNH value of the airport where he will take-off. This action should be carried out on ground, after take-off, change of QNH in Setup/QNH Res menu will adjust altitude reading to actual QNH setting.

Wind calculation

LX Eos is able to measure wind under two different methods. Wind calculation results are shown on main vario page and on thermal assistant page. LX Eos will switch between straight and circling method automatically and history of wind will be counted in new measurements.

Circling:

Calculation is based on ground speed (GS) oscillation due to wind influence in circling. The method is active exclusively during climbing process. The process start automatically after circling is detected. The method is based on fact that the ground speed is affected by wind. GS is maximal by tailwind and minimal by head wind. This phenomenon is used by GS difference calculation method.

Straight flight:

On straight flight, wind will be calculated with use of iterative method which is based on IAS, GS and TRK measurements.

Influence of wind in final glide

The actual wind data (speed and direction) influences the final glide calculation. In task mode, the final glide indication is based on remaining distance over all TP until finish (not over already flown turn points). Wind influence for individual legs is based on current wind data.

Event function

User has option to set one of the user inputs to Event. If event switch is pressed during flight, it will enable faster record interval in flight recorder (recording in shorter intervals as default for a limited time). Event parameters can be set in Setup/Logger on LX Eos unit. The action is accompanied with a clear message.

Task start

It is started automatically when glider leaves start TP observation zone. Navigation to next point will start. If pilot wishes to navigate back to starting point, he must simply use "Goto" option in task setup menu. Please refer to Task page chapter.

No task statistic is available on LX Eos.

After landing

It is recommended to keep the instrument ON for a few minutes after landing. This will ensure base line of baro trace.

10s after landing is detected, statistic page will be shown automatically where 10min countown can be seen.

Pilot can wait for 10min of press enter to end flight. Calculating security message will follow and then logbook will be offered to the pilot. At this point unit can be switched OFF or flight download process can start.

Downloading flights

Insert micro SD card to external micro SD card holder. Select logbook page and search for a flight that you wish to download. Press enter on that flight and select Copy option. Progress window will inform pilot when flight is copied to external SD card. File format of flight is .IGC.

Revision history

Version	Changes
0.7	<ul style="list-style-type: none"> - SD card stability
0.8	<ul style="list-style-type: none"> - selection of APT (Radio enabled) on Zeus will not crash device any-more. - AS CTR zone have transparency 50% fill by default - init memory is required. - selected polar name is correct. - pilot name and surname are displayed correctly on initial selection. - polar is in sync with 2nd seat. - volume, Mc, Bal, Bugs are in sync between 1st and 2nd seat - AS file up to 1.5MB in file size are listed. Bigger are not listed since they can crash device (memory overflow) - charging status is working correctly. - production page on 2nd seat is working correctly. - 2nd seat will show statistic correctly in the flight. - 2nd seat will not show IGC serial No. on INIT screen and info page. - AS and TA settings are initialized on factory reset and on new user. - TP and APT names are shown in upper case. Filter converts them! - production page is refreshed with live data at 5Hz - TP, APT, TSK select is shown correctly for first time. - TP, APT filter is working on upper or lower-case names. Filter is set to empty every time it is selected to be active. - last fix information is displayed on GPS info page and is used as location when bad GPS is detected. - escape button is working correctly on Era in setup and on select TP, APT and TSK menu - fix interval has limit 1-30s
0.9	<ul style="list-style-type: none"> - INIT memory password will clear also user settings. - Graphic navigation pages corrected on Eos80 (steering and plane icon was overlapping each other) - Flarm page is active (Zoom and select are working) Flarm warning, object name and Flarm net list support is still needed to be integrated. - added vario as indicator navbox - MC, SC, thermal symbols are matched with the scale on Eos 80 - external SD card can be removed and put back in and will be detected again. - Joy is supported - setup and task shortcut are not working jet (needs new FW for Joy and needs to update Joy!) - BT name is set correctly (2 times serial No. bug is solved) - many other values are showed and used correctly (pure value returned converted) - SpeedToFly is displayed correctly. - wind is displayed correctly - TA is refreshed correctly
0.9a	<ul style="list-style-type: none"> - Flarm object info is also visible if object is far right (info is then shown on left side of object) - Calculating security will not crash the unit anymore - When selecting KRT2 radio, baud-rates on User ports are set to 9600 automatically and cannot be changed - Flarm radar page will not crash the unit on select with no Flarm objects - Duplicating pilot in pilot list is fixed
0.9b/c	<ul style="list-style-type: none"> - Shutdown option will count 3s before turning off. - Flarm warning screen implemented with beep and voice announcement. - Event info dialog shown on external input or enter on GPS info page. - Info pop up dialog integrated. - INIT dialog waits until all images are cached for operation. - Polar is shown correctly on polar select menu. - Thermal assistant is showing correctly for both direction of circling.

	<ul style="list-style-type: none"> - 10s press on enter button will reset device. - AS warning with visual display, audio beep and voice announcement. - Declaration over BT is working. - Declaration over User port to Oudie / XC is supported now. - Flarm and BT icon are working on status bar. - FL is displayed correctly. - Altitude in ft is displayed correctly when units Ft is set. - Device will show warnings for Stall, Vne, Gear, Airbrakes, Altitude with voice announcement. - All dialogues under transfer have "deselect" option to deselect active TP, APT, AS file. - On new file select, loading progress dialogue will be shown until all new database is loaded. - New design of shutdown and End Flight dialogue. - Stability was made on page changes. - On navigation pages (Eos 80) wind, steering and navigation info have black background to stand out more from all info on screen. - TP and APT symbols are shown on the navigation screens. - Transparency of AS zones is working correctly now. - INIT memory will initialize speed arcs for Eos80 correctly. - Inverted inputs are working correctly. - After initial setup, all databases (APT, AS, TP) are loaded and progress bars are shown until finished. - Stability at calculating security. - INIT memory will also delete APT files from internal memory. - requires new external .bin
0.9d	<ul style="list-style-type: none"> - Added track line on task page. - Final Glide on task finish TP is working correctly. - SD card stability when working with internal and external is now correct. - wind speed can be selected as m/s unit. - event interval is fixed at 1s. - event records can be set from 30 to 60. - when changing vario units on Era, vario scale will not oscillate anymore. - if units ft are chosen, initial elevation is working correctly. - altitude (ft) has now label ALT and units ft (before was label QHN and no units). - ranges on G-force page are working correctly (they change with press on the button). - Flarm icon will disappear if Flarm is disconnected. Voice will be told only once per power cycle. Flarm disconnected voice message is not possible to generate (is not in database). - BT icon will also disappear when BT connection is lost. - INIT setup and QNH change is working correctly when pressure is set to inHg. - MC range is corrected when kts are used (up to 10kts). - pilot weight and reserve are stored correctly if you select new pilot. - wind will be shown correctly in Zeus configuration.
0.9e/f	<ul style="list-style-type: none"> - 2nd seat Era will work correctly in Zeus configuration. - automatic switch to TA page is supported. - TA options menu added to set auto TA, maxBeep, beep offset and MC colouring - shortcut Task and Setup from Joy are now supported. - sort by distance, Name and code / ICAO supported for TP and APT. - added exit on the end of task edit option. - AHRS page activated. - Speeds below 0 are not shown any more on speed type on TA and G- force page (LX Era). - select filter for TP, APT on task edit is working correctly. - weight is changed to mass. - Joy up /down are working correctly on Volume setting menu. - overlapping of text and icon on TP select or task edit is corrected now. - back character is shown correctly.

	<ul style="list-style-type: none"> - G-force background picture is now more visible. - G-force menu is working on Eos80. - There is no zoom visible in Task TP / APT selection dialogue. - Joy up/down are working on vario, TA, logbook, setup page to change volume.
0.9g/h	<ul style="list-style-type: none"> - AHRS is working correctly - Lite version has now option to forward GGA and RMC from Flarm port to BT and user port. - update file will be found also if user has selected before AS file (It still got file size restriction and was not reseated correctly) - APT and TP are selected correctly on Eos80. - Name of TP in task edit is shown correctly also for long names. - Sn is displayed correctly on Eos80 - Sn is displayed correctly if Lite version is detected (no IGC sn and position) - Lite version will display options under info menu. - AHRS page will show red X when AHRS module is not connected to CAN or when AHRS is disabled. - Empty navbox value is now correct. - on GPS bad all navigation pages have red X across the screen. - needle on Era is fully refreshed every 0.8s to avoid and leftovers due to big pressure changes. - audio test is working. - character ~ is working correctly on file select. - added vario silence range. - added max SC speed. - load task option enabled. - user polar is saved now correctly. DAeC index is not visible under user polar. - battery symbol is showing correctly backup battery status. - 2.5m/s vario scale on Era is working correctly. - sort setting for TP and APT is now saved. By default, distance is selected. - TP names are visible on navigation pages and also TP/APT icon is shown as dot or icon depending on numbers of it displayed. - dimming option added on quick menu. - altitude graph on statistic page has Y axe labelled. - view zone under task edit menu is implemented. - airspace warnings can be disabled under Warnings menu. - Flarm NET list is supported and Flarm object info is shown under Flarm options. - callsign is shown on radar screen if exists in Flarm NET database.



LX
navigation

