

Professional Weather Station

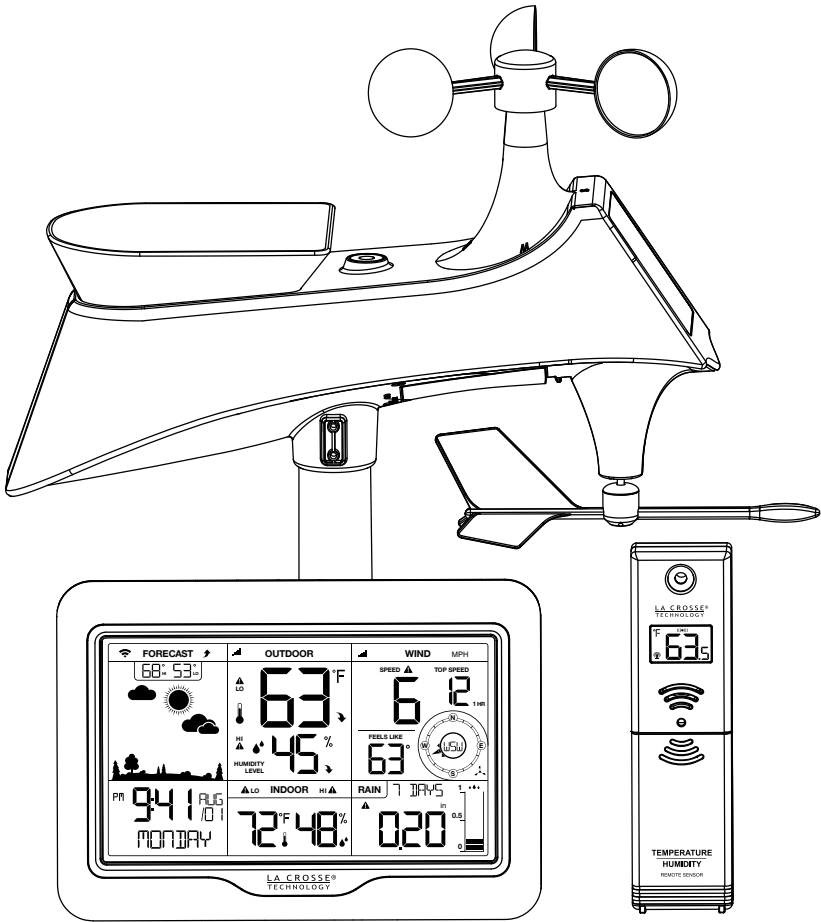

For online video support:
<http://bit.ly/LaxTechTalk>

Instructional Manual

Model: S85807 DC:090616

Table of Contents

Setup Preparation	2
Setup	2
Display Icons	5
Wind Readings	5
Wind History	6
Rain Readings History	6
Temperature/ Humidity HI LO .	8
Weather Alerts	9
Set Weather Alerts	10
Weather Forecast Icons	11
Seasonal Trees	11
Sensor Search	12
Mounting Instructions	13
Replace Wind Cups	14
Replace Directional Vane	15
Factory Restart	15
Follow Us on Social Media	16
WIFI Icon	17
Specifications	18
Care and Maintenance	18
Warranty and Support	19
FCC Statement	19
Canada Statement	19

Setup Preparation

Here are some items needed to setup your station (not included):

1. Phillips head screwdriver for assembly.
2. Fresh Batteries: 5 (five) AA alkaline or lithium batteries for the sensors.
3 (three) AAA alkaline batteries for the station (optional).

For best results:

- Remove weather station and sensors from the package and place together on a table or bench, within easy reach.
- Place batteries and screwdriver within reach of setup location.
- Keep sensors and weather station 5-10 feet apart for the first 15 minutes after installing batteries.

Setup

- ① **Power up.** Observe correct polarity.
- Thermo-hygro sensor- 2-AA batteries
 - Multi-sensor- 3-AA batteries
 - Weather Station- 5.0 Volt AC adapter and 3-AAA batteries (optional)

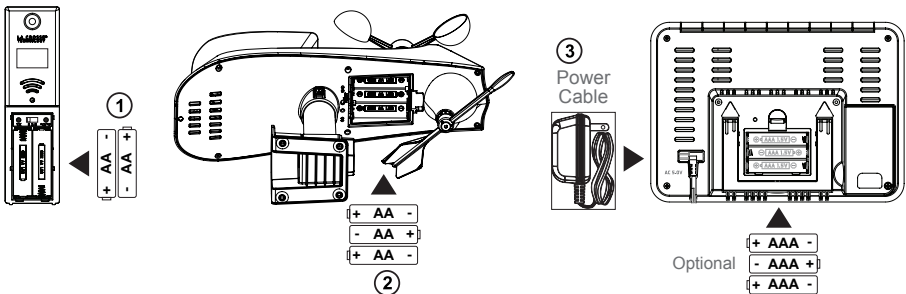

Note: Batteries are not included

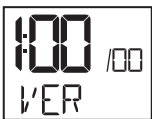

Software version will show for 2 seconds. Lower left corner.

- ② **Place sensors outdoors** at least 6 feet above objects below them (ground, roof, etc.)
- Thermo-hygro sensor-Place in a shaded location to protect from sun.
 - Multi-sensor- Place in an open area. No obstructions for 50 feet in all directions.
- Enjoy your backyard weather!

3 Configure basic settings. Hold the SET button to enter settings. Press and release the +/- buttons to make adjustments and the SET button to confirm.

Settings order:

- BEEP ON/OFF
- Time zone (-12 to +12)
- Auto DST ON/OFF (Daylight Saving Time)
- Hour
- Minutes
- 12h/24h hour format
- Year
- Month
- Date
- Temperature (C/F)
- Wind degree or direction (letters) select
- Wind speed select (mph/kmh)
- Rainfall unit select (in/mm)

North America Time Zones	
-4h	Atlantic
-5h	Eastern
-6h	Central
-7h	Mountain
-8h	Pacific
-9h	Alaska
-10h	Hawaii

1. BEEP ON | OFF

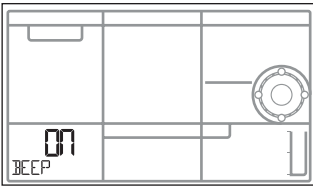

2. Time Zone (-12 to + 12)

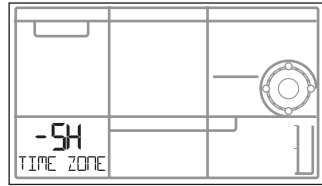

3. Auto DST ON | OFF

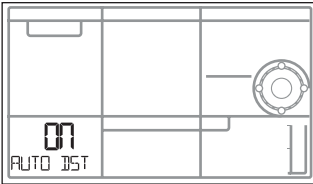

4. Hours

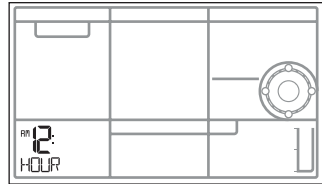

5. Minutes

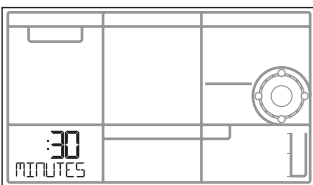

6. 12 | 24 Hour Format

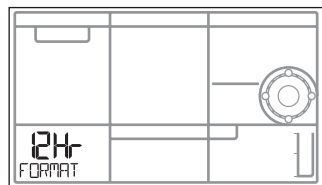

7. Year

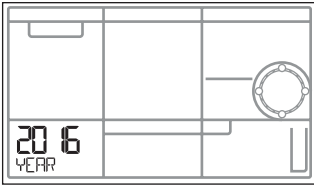

8. Month

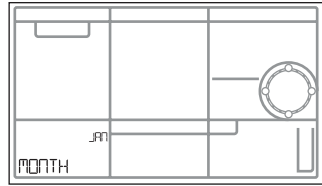

9. Date

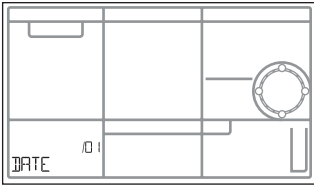

10. Fahrenheit | Celsius

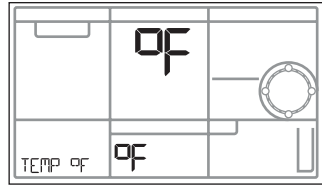

11. Wind Direction (degrees | letters)

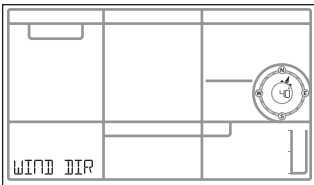

12. Wind Speed (MPH | KMH)

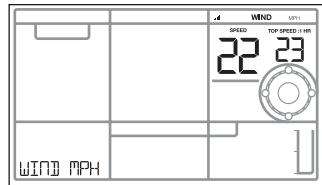



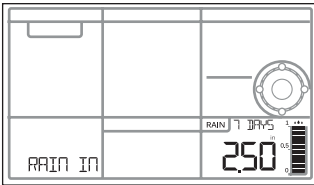





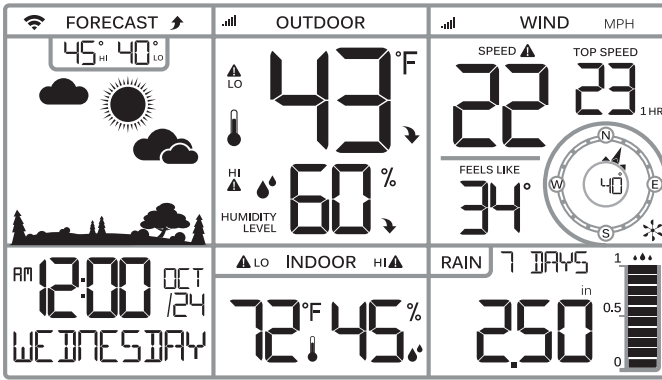





13. Rain (INCH | MM)



- Press the LIGHT button at any time to exit.
- After 30 seconds with no button press, the station will default back to normal time display.

Display icons



-  WIFI Strength
-  Trend Arrows
-  Sensor Strength
-  HI | LO Alert
-  °F °C Fahrenheit | Celsius
-  Forecast Icon
-  Seasonal Trees
-  Temperature
-  % Percent Humidity
-  Humidity
-  Wind Direction
-  Wind Speed
-  Rainfall Graph

Wind Readings

- Current Speed: Highest speed past 30 seconds
- Top Speed: Highest speed in the past hour
- Feels Like: Temperature | Humidity | Wind Speed

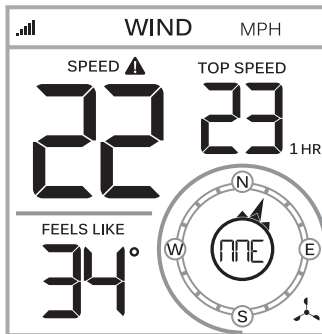

- Wind Direction: In letters or degrees
- History: Press and release the WIND button to view:
1 Hour (default) | 24 Hour | 7 Days | Month | Year

Wind History

Press and release the WIND button to view the maximum wind history values.

- One Hour: past 60 minute period (default Top Speed record, already shown)
- 24-hour: Past 24 hour period, from last record
- 7 Days: Past 7-day period, from last record
- Month: Defined by Calendar Month i.e. January 1 - January 31
- Year: Defined by Calendar Year i.e. January 1 - December 31

Reset Wind Speed History:

- Press the WIND button to view individual wind speed readings.
- Hold the MINUS button for five seconds to reset the individual value.
- Wind speed reading will reset to current wind speed.

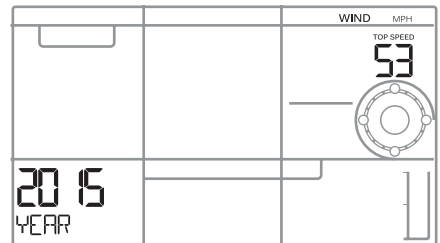
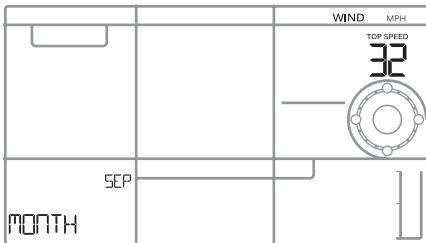
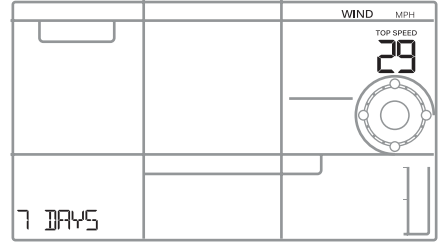
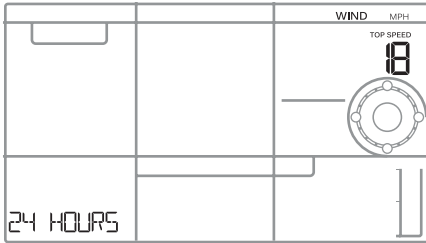

Rain Readings | History

Press and release the RAIN button to view:

- One Hour: past 60 minute periods, from last record
- Day: 24 hr period from 12:00am - 11:59pm. With current date
- 24-hour: Past 24 hour period, from last record.
- 7 Days: Past 7-day period, from last record
- Month: Defined by Calendar Month i.e. January 1 - January 31.
- Year: Defined by Calendar Year i.e. January 1 - December 31.
- Total: running total since station was powered up (no time stamp)

- Select your rain history and the station will keep your selection.
- After viewing a history record for 5 seconds, the station will return to the normal view.

One Hour

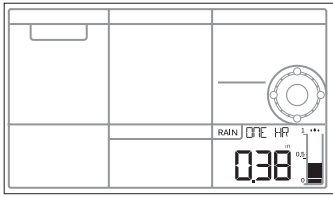

24 Hours

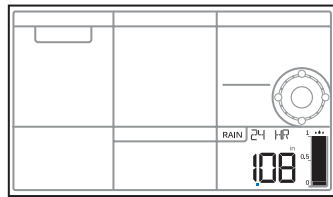

Day (12:00am - 11:59pm)

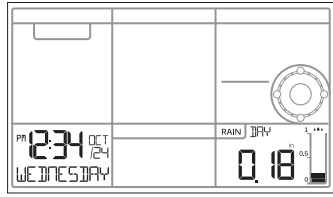

7 Day

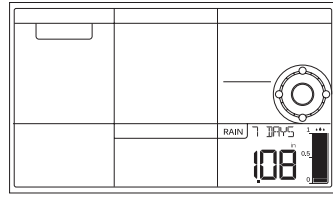

Month

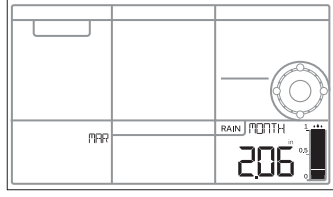

Year

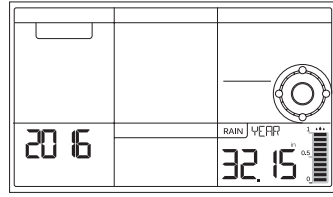

Total

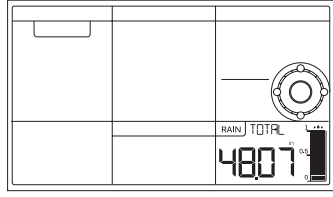

Reset Rainfall Readings (each resets individually):

- Press the RAIN button to view individual rain readings.
- Hold the MINUS button for five seconds to reset the individual value.
- Rainfall reading will reset to 0.00

Temperature/Humidity HI | LO Readings

Press and release to view HI/LO temperature and humidity readings with time/date stamp.

- Outdoor temperature HIGH
- Outdoor temperature LOW
- Outdoor humidity HIGH
- Outdoor humidity LOW
- Indoor temperature HIGH
- Indoor temperature LOW
- Indoor humidity HIGH
- Indoor humidity LOW
- Feels like HIGH
- Feels like LOW
- Outdoor dew point

Note: Feels Like and Dew Point is not time/date stamped.

Outdoor Temp HI

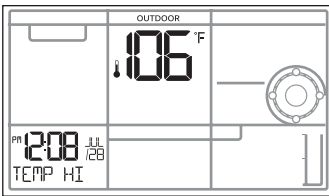

Outdoor Temp LO

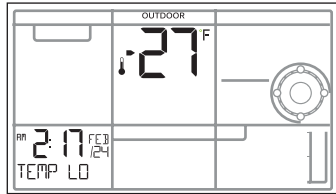

Outdoor Humidity HI

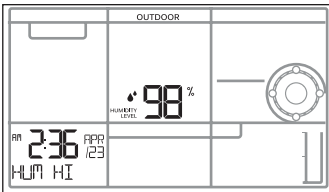

Outdoor Humidity LO

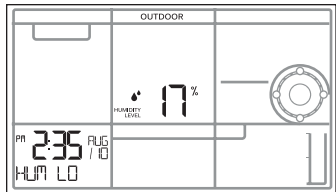

Indoor Temp HI

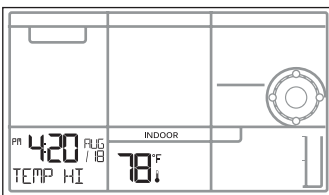

Indoor Temp LO

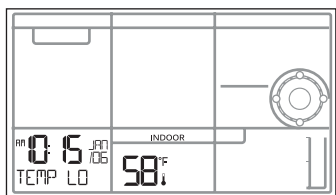

Indoor Humidity HI

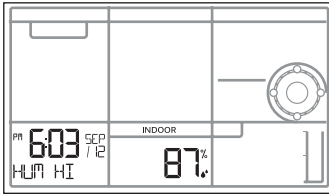

Indoor Humidity LO

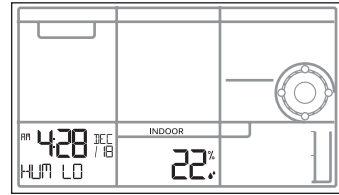

Feels Like HI

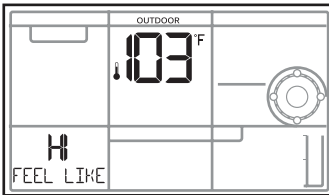

Feels Like LO

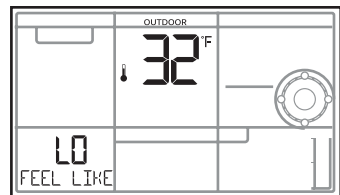

Dew Point

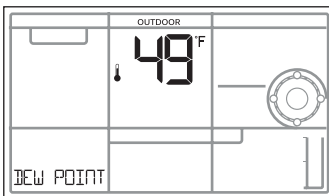

Types of Weather Alerts

There are 20 weather alerts available on this weather station.

- Outdoor LOW Temperature ON/OFF
- Outdoor LOW Temperature Value -40°F-140°F (-40°C-60°C)
- Outdoor HIGH Temperature ON/OFF
- Outdoor HIGH Temperature Value -40°F-140°F (-40°C-60°C)

- Outdoor LOW Humidity ON/OFF
- Outdoor LOW Humidity Value 10%RH-99%RH
- Outdoor HIGH Humidity ON/OFF
- Outdoor HIGH Humidity Value 10%RH-99%RH

- Indoor LOW Temperature ON/OFF
- Indoor LOW Temperature Value 32°F-122°F (0°C-50°C)
- Indoor HIGH Temperature ON/OFF
- Indoor HIGH Temperature Value 32°F-122°F (0°C-50°C)

- Indoor LOW Humidity ON/OFF
- Indoor LOW Humidity Value 10%RH-99%RH
- Indoor HIGH Humidity ON/OFF
- Indoor HIGH Humidity Value 10%RH-99%RH
- 24-hour Rainfall ON/OFF
- 24-hour Rainfall Value 0-393 inches (0-99.9mm)
- High Wind Speed ON/OFF (CURRENT wind)
- High Wind Speed Value 0-111.8 (0-180kph) (CURRENT wind)

Set Weather Alerts

Hold the ALERTS button 2 seconds to enter alert set mode. Outdoor Low Temperature alert OFF will show.

ALERT ON:

1. Press the +/- buttons to arm the alert.
2. Press the ALERTS button and the alert value will flash
3. Press the +/- buttons to set the alert value (Hold to set quickly).
4. Press ALERTS button to move to next alert.

ALERT OFF:

1. Alerts are OFF unless armed. If you do not wish to set an alert, simply press the ALERTS button again to move to the next alert.

Alert OFF use +/- to arm

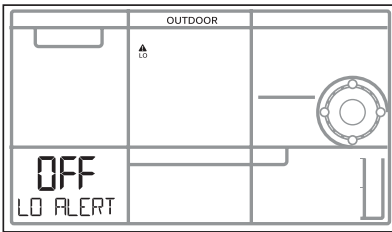

Alert ON use +/- to set value

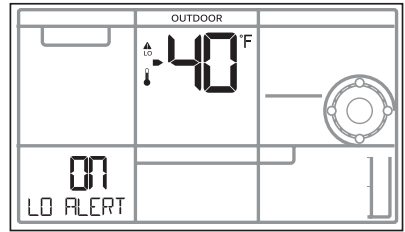

Active Alert:

- When armed alert value is reached, station will beep 5 times each minute, until out of alert range.
- The flashing alert icon will indicate if is a LOW or HI alert.

HI  LO

- Press any button to stop the alert sound.
- The alert icon will flash while value is in alert range.

Weather Forecast Icons

- The forecast icons are determined by the barometric pressure sensor.
- The tendency arrow shows the changes on the barometric pressure is rising or falling.
- When Outdoor temperature is below 32 F and the forecast is RAIN or T-STORM, the LCD will display SNOW.

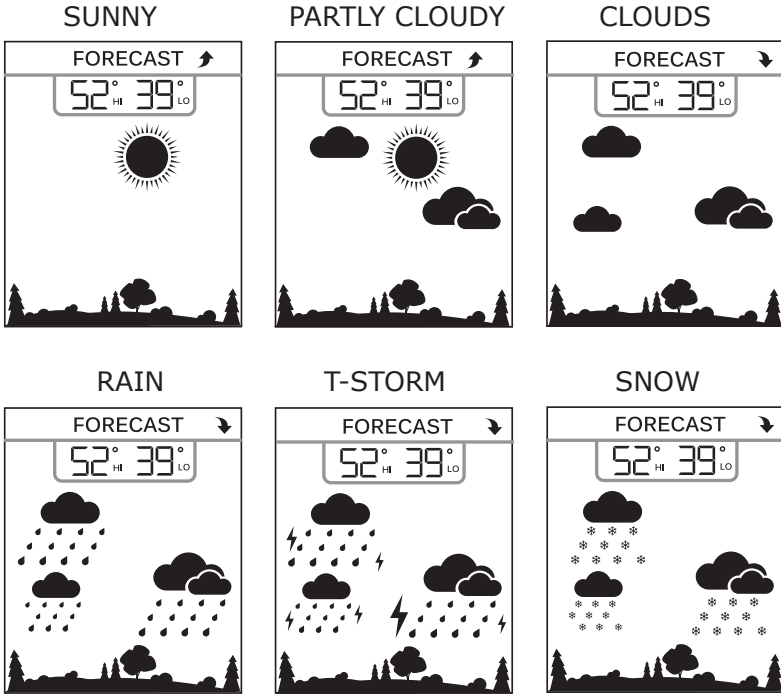

Seasonal Trees

- The trees and foliage color will change seasonally. The dates are programmed into the weather station for the scene to change automatically.

Spring: March 20th – Jun 20th

Summer: Jun 21st – Sep 20th



Autumn: Sep 21st – Dec 20th

Winter: Dec 21st – Mar 19th



Sensor Search

Each sensor has a unique ID and will be “parked” to the correct sensor location on the display until manually deleted.

- If sensor loses connection to the weather station for any reason, the weather station will show dashes after 30 minutes.
- The weather station will search for 5 minutes every hour to reconnect with sensor.

1. In normal mode press and release the SENSOR button to view individual sensor ID’s for up to 15 seconds.
2. Press and release the + button to search for the sensor, who’s ID is shown.

TH Sensor ID

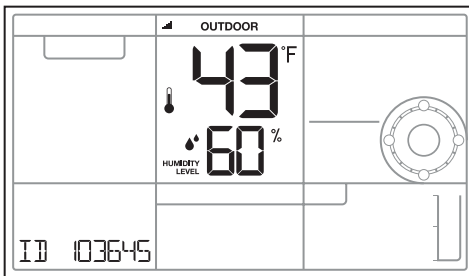

Multi-sensor ID

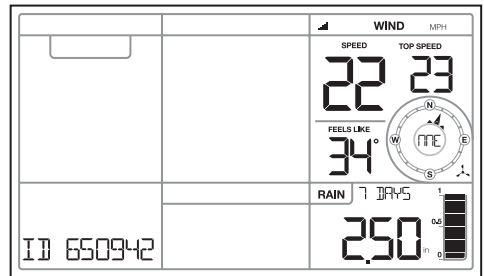

3. The strength signal icon will animate until the sensor signal is received, or for 3 minutes if no signal available.



Delete Sensor:

1. Press the SENSOR button to view individual sensor ID.
2. Hold the - button for 5 seconds to delete the sensor and ID.

TH Sensor Deleted

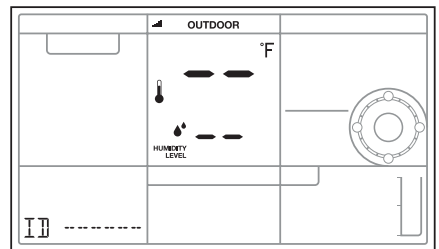

Add Sensor:

1. Install batteries in sensor.
2. Press and release the SENSOR button to view sensor area (dashes).
3. Press the + button to search.
4. Press the TX button on sensor.
5. When sensor connects, ID and readings show.

Mounting Instructions

TX232TH-LCD Temperature/Humidity Sensor

Option 1:

- Install one mounting screw into a wall leaving some extended.
- Place the transmitter onto the screw, gently pull the transmitter down to lock the screw into place.

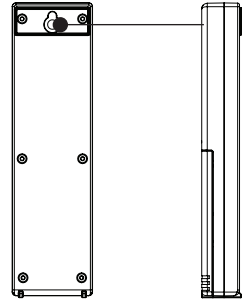

Option 2:

- Insert the mounting screw through the front of the transmitter and into the wall.
- Tighten the screw to snug (do not over tighten).
- Mount the temperature/humidity sensor on a north-facing wall or in any well shaded location. Sun will make it read high.
- Under an eave or deck rail is preferred.
- Be sure the outdoor sensor is mounted vertically to drain moisture.
- Avoid mounting under a metal roof and use stainless steel screws for best WWVB reception and RF transmission.

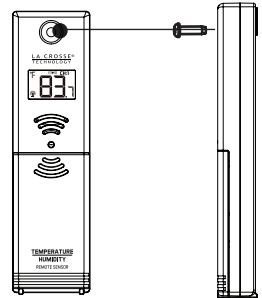

- The maximum wireless transmission range to the weather station is over 330 feet (100 meters) in open air, not including walls or floors.

TX231RW Multi-sensor

- For most accurate wind speed and rainfall readings, mount the Multi-sensor in an open area clear for 50 feet in all directions.
- Mount with the solar panel facing south so the wind direction is correct. See N, S, E W, embossed on the top of the sensor.
- Use the bubble level on the top of the sensor to ensure it is level, for accurate rainfall readings.

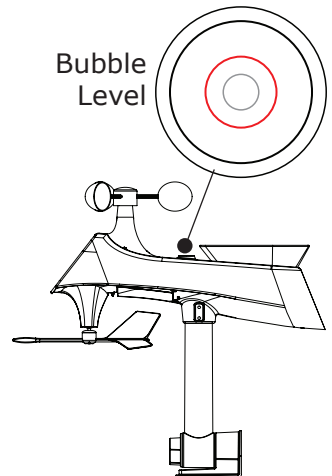

- The maximum wireless transmission range to the station is over 330 feet (100 meters) in open air, not including walls or trees.
- Mount sensor vertically.
- Cups should be on the top of the sensor.
- Attach to mounting surface with screws through the mounting bracket.
- The sensor can be mounted from the bottom or from the side.

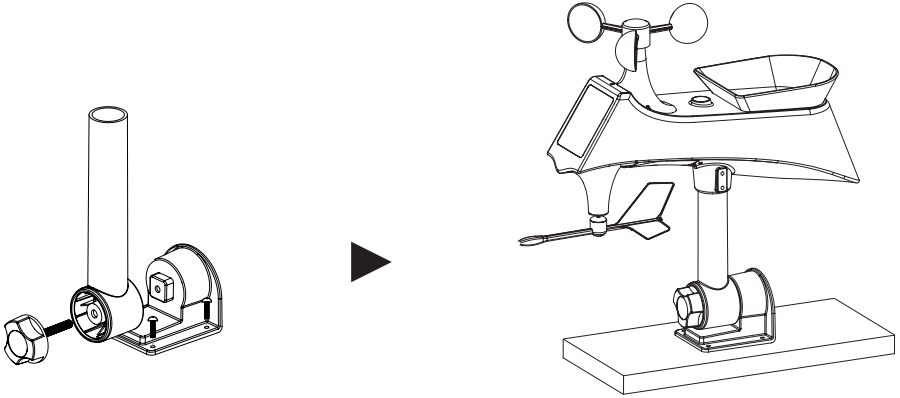

Alternatively:

- Insert your own mounting pole sensor.
- Tighten screws
- Mounting bracket would not be used.

Replace Wind Cups

1. Loosen the screw on side of cups
2. Remove cups
3. Install new cups
4. Tighten screw

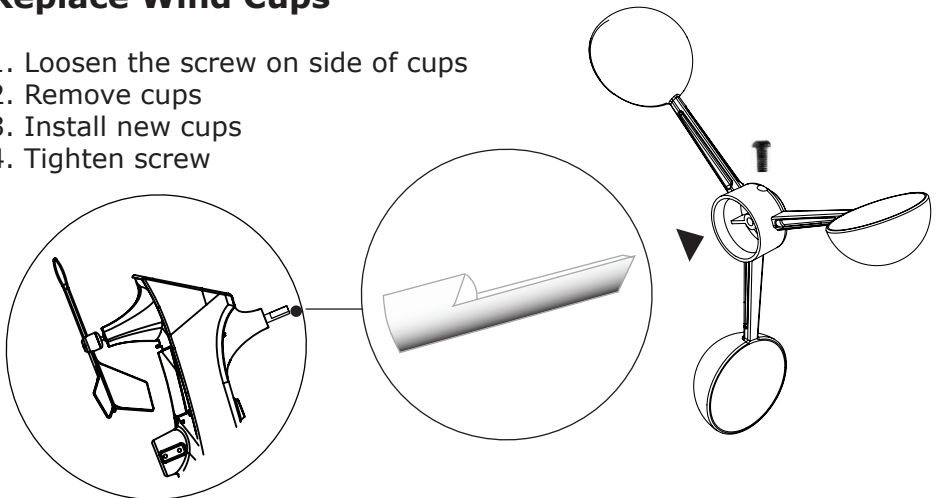

Replace Directional Vane

1. Loosen the screw on side of vane
2. Remove direction vane
3. Install new vane
4. Tighten screw

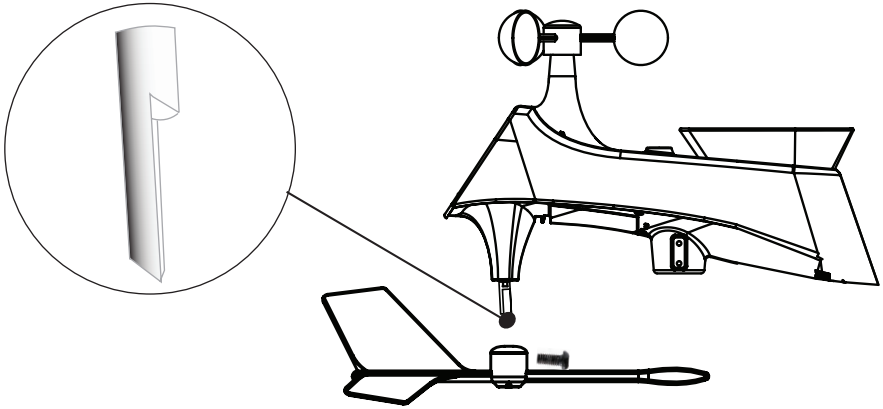

Factory Restart

The factory reset will return the weather station to its default settings. This will clear all previous recorded history, so you may want to write down data before taking this step.

1. Hold the **LIGHT** and **ALERTS** buttons together for 5 seconds to reset the weather station, clear all records, and return all settings to default.
2. The weather station will fully populate, then return to a normal display and search for outdoor sensors.
3. While searching for the outdoor sensors the Wind Speed, Outdoor Temperature/Humidity and Rainfall totals will show dashes.
4. Once connected to the outdoor sensors (allow 3 minutes) the Wind Speed, Outdoor Temperature/Humidity, and Rainfall will show current readings.

Follow Us on Social Media



Latest video content
http://bit.ly/LaxTech_YouTube



For personal interaction
http://bit.ly/LaxTech_Facebook



Join the conversation
http://bit.ly/LaxTech__Twitter



Pin and share
http://bit.ly/LaxTech_Pinterest

WIFI Icon

- The connected icon will flash while station is searching for WIFI connection. It will flash up to 1 hour.
- The station must operate on AC power for the WIFI to work.

Slow Flash - no WIFI network connection-check connection

Fast Flash - configure Weather Connect APP

Solid - Connected



Not displayed -No WIFI router-check router

Note: Hold the PLUS and MINUS buttons together for 3 seconds to reconnect, if WIFI signal is lost.

Get Connected: Connect your new weather station to the Weather Underground with our Weather connect APP.



Weather Connect

Note: The Weather Connect App is only for connecting your weather station to Weather Underground

When connected:

- Time and date will come from the Internet (set your own time zone)
- View you backyard weather on your phone.
- WI-FI icon will animate according to signal strength.



Specifications

Indoor	<ul style="list-style-type: none"> • Temperature Range: 32°F to 122°F (0°C to 50°C) • Humidity Range: 10% to 99% RH • Update interval: About every 60 seconds
TH Sensor	<ul style="list-style-type: none"> • Temperature Range: -40°F to 140°F (-40°C to 60°C) • Humidity Range: 10% to 99% RH • Update interval: About every 58 seconds • Transmission Range: 330 ft (100 m) RF 915MHz open air
Multi-sensor	<ul style="list-style-type: none"> • Wind Speed Range: 0-111.8 mph (0-180 kmH) • Wind Direction: 0-359 degrees • Rainfall: 0-393.7 inches (0-9999 mm) • Update interval: About every 30 seconds • Transmission Range: 330 ft (100 m) RF 915MHz open air
Power	<ul style="list-style-type: none"> • Weather Station: 5.0 Volt 500mA adapter included (Primary) • AC6: HX06-0500500-AU • Optional Battery: 3-AAA, IEC, LR3 batteries (not included)
Battery Life	<ul style="list-style-type: none"> • TX233RW: 3-AA, IEC, LR6 batteries (not included) • TX233TH: 2-AA, IEC, LR6 batteries (not included) <ul style="list-style-type: none"> • Weather Station: 60 to 48 months when using adapter. • Multi-sensor/TH sensor: over 24 month with reputable batteries
Dimensions	<ul style="list-style-type: none"> • Weather Station: 8.05" W x 5.70" H x 1.36" D in (204.47 W x 144.78 H x 34.54 D mm) • TX233RW Multi-sensor: 13.61" W x 8.55" H x 5.14" D (345.69 W x 217.17 H x 130.55 D mm) • TX233TH Sensor: 1.67" W x 6.14" H x 0.83" D (42.42 W x 155.96 H x 21.08 D mm)

Care and Maintenance

- Do not mix old and new batteries
- Do not mix Alkaline, Standard, Lithium or Rechargeable Batteries
- Always purchase the correct size and grade of battery most suitable for the intended use.
- Replace all batteries of a set at the same time.
- Clean the battery contacts and also those of the device prior to battery installation.
- Ensure the batteries are installed correctly with regard to polarity (+ and -).
- Remove batteries from equipment which is not to be used for an extended period of time.
- Promptly remove expired batteries promptly.

Warranty and Support

La Crosse Technology, Ltd. provides a 1-year limited time warranty (from date of purchase) on this product relating to manufacturing defects in materials & workmanship.

Before returning a product, please visit the product web page for more information or contact our friendly customer support:

Online product web page: www.lacrossetechnology.com/S85807

Phone: 1-608-785-7921

View full warranty online at: http://www.lacrossetechnology.com/warranty_info_it/

FCC Statement

This equipment has been tested and found to comply with the limits for a Class B digital device, pursuant to part 15 of the FCC Rules. These limits are designed to provide reasonable protection against harmful interference in a residential installation. This equipment generates, uses and can radiate radio frequency energy and, if not installed and used in accordance with the instructions, may cause harmful interference to radio communications. However, there is no guarantee that interference will not occur in a particular installation.

If this equipment does cause harmful interference to radio or television reception, which can be determined by turning the equipment off and on, the user is encouraged to try to correct the interference by one or more of the following measures:

- Reorient or relocate the receiving antenna.
- Increase the separation between the equipment and receiver.
- Connect the equipment into an outlet on a circuit different from that to which the receiver is connected.
- Contact the dealer or an experienced radio/TV technician for help.

This device must not be co-located or operating in conjunction with any other antenna or transmitter.

Operation is subject to the following two conditions:

- (1) This device may not cause harmful interference, and
- (2) This device must accept any interference received, including interference that may cause undesired operation.

Caution!

The manufacturer is not responsible for any radio or TV interference caused by unauthorized changes or modifications to this equipment. Such changes or modifications could void the user authority to operate the equipment.

All rights reserved. This manual may not be reproduced in any form, even in part, or duplicated or processed using electronic, mechanical or chemical process without the written permission of the publisher. This booklet may contain errors or misprints. The information it contains is regularly checked and corrections are included in subsequent editions. We disclaim any responsibility for any technical error or printing error, or their consequences. All trademarks and patents are recognized.

This equipment must be installed and operated in accordance with provided instructions and the antenna(s) used for this transmitter must be installed to provide a separation distance of at least 20 cm from all persons and must not be co-located or operating in conjunction with any other antenna or transmitter

Canada Statement

This device complies with Industry Canada's licence-exempt RSSs

Operation is subject to the following two conditions:

- (1) This device may not cause interference; and
- (2) This device must accept any interference, including interference that may cause undesired operation of the device.

Le présent appareil est conforme aux CNR d'Industrie Canada applicables aux appareils radio exempts de licence.

L'exploitation est autorisée aux deux conditions suivantes :

- (1) l'appareil ne doit pas produire de brouillage;
- (2) l'utilisateur de l'appareil doit accepter tout brouillage radioélectrique subi, même si le brouillage est susceptible d'en compromettre le fonctionnement.

The device meets the exemption from the routine evaluation limits in section 2.5 of RSS 102 and compliance with RSS-102 RF exposure, users can obtain Canadian information on RF exposure and compliance.

Le dispositif rencontre l'exemption des limites courantes d'évaluation dans la section 2.5 de RSS 102 et la conformité à l'exposition de RSS-102 rf, utilisateurs peut obtenir l'information canadienne sur l'exposition et la conformité de rf.

This transmitter must not be co-located or operating in conjunction with any other antenna or transmitter. This equipment should be installed and operated with a minimum distance of 20 centimeters between the radiator and your body.

Cet émetteur ne doit pas être Co-placé ou ne fonctionnant en même temps qu'aucune autre antenne ou émetteur.

Cet équipement devrait être installé et actionné avec une distance minimum de 20 centimètres entre le radiateur et votre corps.