

IEEE1394 Integrated PCI Host Adapter

User's Manual

May 2000

Description

This 3-port IEEE1394 host adapter is a high speed input/output device for connecting peripherals to a computer, the IEEE1394 is one of the fastest standard ever developed, multimedia devices such as video camcorders and other high-speed devices can take advantage of this standard.

This host adapter is OHCI compliant thus no driver is needed under Windows® 98 Second Edition , its convenient I/O offers “hot plug” feature, it is not necessary to turn off the power when attach/detach any IEEE1394 devices. The IEEE-1394 is a peer-to-peer technology, which means you can connect other systems on the same 1394 bus, two or more computers can share the same IEEE-1394 devices when they are daisy-chained on the same 1394 bus.

Features

- 3-Port IEEE1394 host adapter.
- Compatible with standard Microsoft 1394 driver stack.
- P1394a 3.0 compliant
- OHCI 1.0 compliant
- PCI 2.1 compliant
- 100 to 400 Mbits/s transmission speed
- High speed digital serial bus supporting peer-to-peer communication and hot plug-and-play with 6-wire cable and connector.
- Support for efficient data flow (large FIFO' s, context support)
- Implemented in digital 3.3v, CMOS process technology, 5v tolerant buffers

1 Card Figure

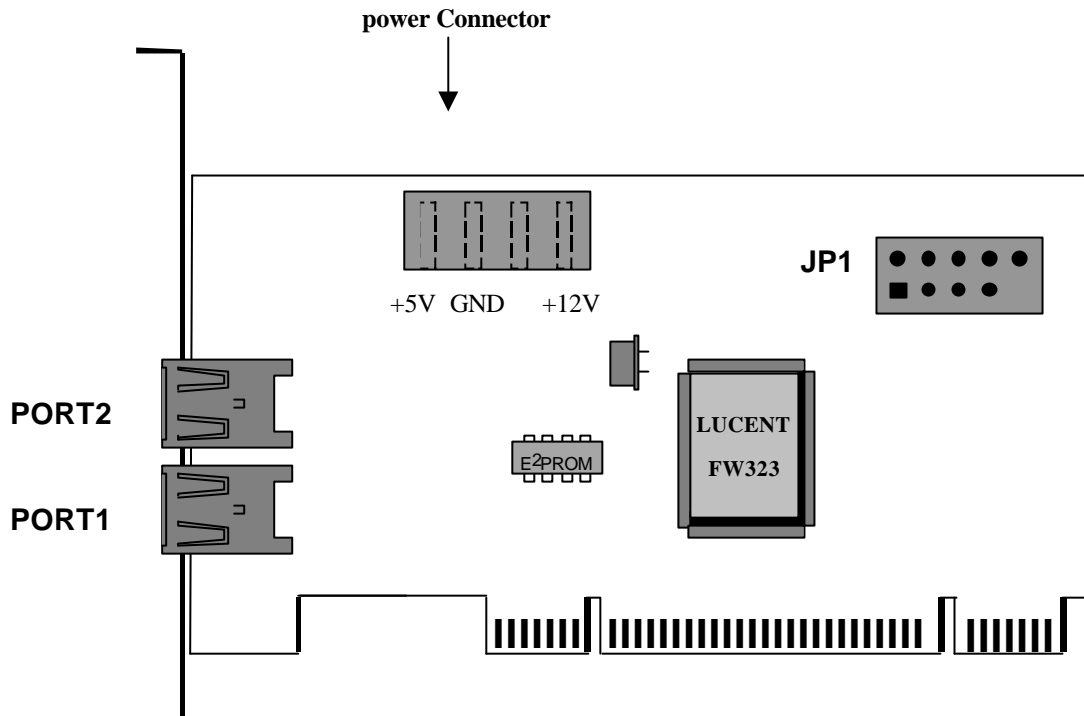

Power Connector
necessary.

2 Installing the IEEE 1394 Host Adapter

1. Power off the system and all peripheral devices. Unplug all power cords from the power utility outlets.

Momentarily touch the chassis of the system unit with your bare hand to discharge

- 3.
- 4.
5. install it into the expansion slot.
6. Secure the host adapter with the screw removed earlier.

-
7. Put back the system unit cover.
 8. Plug all power cords into power utility outlets.
 9. Power on the system and install the appropriate software driver..

3 Installing the IEEE-1394 Host Adapter under Win98 Second Edition

** You have to use the Windows® 98 Second Edition to install the IEEE-1394 Host Adapter ***

- 1 After you have inserted the IEEE-1394 host adapter into you computer, turn on the power, the Win98SE will find the device automatically and the “Add New Hardware Wizard” dialog box will appear, please click “**Next**” to continue.
- 2 The next “Add New Hardware wizard” dialog box appears, please select “Search for the best driver for your device [Recommended]” and click “**Next**”
- 3 Windows will ask you to specify the driver location, please specify where your Windows system disk is located (ex. Win98SE) and click “**NEXT**”
- 4 Windows will tell you that the IEEE-1394 host adapter has been found in the specified location, please click “**NEXT**” to continue.
- 5 At the last step, Windows will you inform you that the installation has finished, please click “**Finish**” to finish installing the IEEE-1394 driver.

May.2000

FCC COMPLIANCE STATEMENT:

This device complies with part 15 of the FCC Rules. Operation is subject to the following two conditions: (1) This device may not cause harmful interference, and (2) this device must accept any interference received, including interference that may cause undesired operation.

INFORMATION TO USER:

This equipment has been tested and found to comply with the limits of a Class B digital device, pursuant to Part 15 of the FCC Rules. These limits are designed to provide reasonable protection against harmful interference in a residential installation. This equipment generates, uses and can radiate radio frequency energy and, if not installed and used in accordance with the instructions, may cause harmful interference to radio communications. However, there is no guarantee that interference will not occur in a particular installation; if this equipment does cause harmful interference to radio or television reception, which can be determined by turning the equipment off and on, the user is encouraged to try to correct the interference by one or more of the following measures:

- 1. Reorient / Relocate the receiving antenna.*
- 2. Increase the separation between the equipment and receiver.*
- 3. Connect the equipment into an outlet on a circuit different from that to which the receiver is connected.*
- 4. Consult the dealer or an experienced radio/TV technician for help.*

CAUTION: Changes or modifications not expressly approved by the manufacturer responsible for compliance could void the user's authority to operate the equipment