

0

T R A N S C E I V E R

9

4

4

C

A

AEROCOMM'S MOTTO OF "INSTANT WIRELESS" EXPRESSES OUR COMMITMENT TO FACILITATING FAST AND EASY RF INTEGRATION. OUR COMPREHENSIVE DEVELOPMENT TOOLS AND ENGINEERING SUPPORT HELP OEMS ACCELERATE TIME-TO-MARKET.

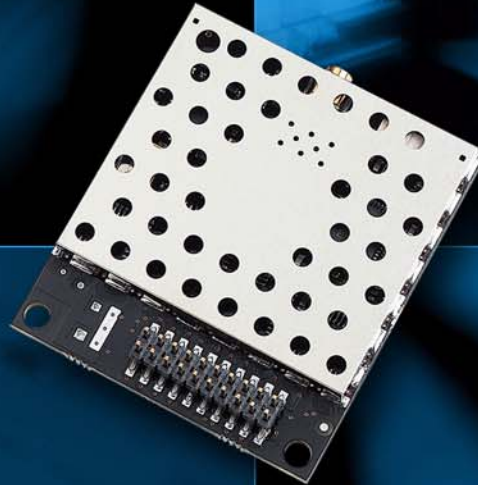

U S E R
M A N U A L
VERSION 3.1



Contents

AC4490 TRANSCEIVER MODULE 1

AC4490 features 1
Overview 1

SPECIFICATIONS 3

Pin Definitions 4
Electrical Specifications 6

THEORY OF OPERATION 7

RF Architecture 7
Modes of Operation 7
 Transmit Mode 7
 Receive Mode 7
 Command Mode 8
API CONTROL 8
 Receive API Packet 9
 API Transmit Packet 9
 API Send Data Complete 9
 API Receive Packet 9
Protocol Status/Receive Acknowledgement 10
 Protocol Status 10
 Receive Acknowledgement 10
Long Range Mode 10

SERIAL INTERFACE 12

Serial Communications 12
 Asynchronous Operation 12
 Parity 12
OEM Host Data Rate 13
Serial Interface Baud Rate 13
Interface Timeout / RF Packet Size 14
Flow Control 15
Half Duplex / Full Duplex 15
System Timing & Latency 15
System Throughput 16

SOFTWARE INTERFACE 17

Networking 17
One Beacon Mode / Range Refresh 18
Auto Config Parameters 18
Interface Options 19
 Modem Mode 19
 RS485 Modem Mode 20
Max Power 20

TIMING DIAGRAMS 21

AC4490 Timing Diagrams 21

HARDWARE INTERFACE 23

Pin Definitions 23

Generic I/O 23
TXD & RXD 23
Hop Frame 23
CTS 23
GND 23
RTS 23
Test / 9600 Baud 24
RSSI 24
UP_Reset 25
Command/Data 25
AD In 25

CONFIGURING THE AC4490 26

AT Commands 27
 On-the-Fly Control Commands 27
Command Descriptions 30

EEPROM PARAMETERS 36

DIMENSIONS 40

Mechanical Drawings 40

ORDERING INFORMATION 44

Product Part Number Tree 44
Developer Kit Part Numbers 44

COMPLIANCE INFORMATION 45

AC4490-1x1 45
Agency Identification Numbers 45
Approved Antenna List 45
FCC / IC Requirements for Modular Approval 46
OEM Equipment Labeling Requirements 46
Antenna Requirements 47
Warnings required in OEM Manuals 47
Channel Warning 47

APPENDIX I - SAMPLE POWER SUPPLY 48

Bill of Materials 48
Schematic 49
PCB Layout 49

APPENDIX II - 5V TO 3.3V LEVELS 51

Voltage Level Conversion IC's 51
Passive Resistor Voltage Divider 51

APPENDIX III - API 52

Polling Network 52
 Addressed Transmit API 53
 Broadcast Transmit API 53
 Receive API 54

Contents

Enhanced Receive API	55
Normal Receive Mode (non-API)	55
Loopback Repeater	55
Time Division Multiple Access Network	56

APPENDIX IV - SYNC TO CHANNEL 57

Sync to Channel	57
What is it and do I need it?	57
How do I configure Sync to Channel?	59
I've configured my radios, what's next?	65

Copyright © 2007 AeroComm, Inc. All rights reserved.

The information contained in this manual and the accompanying software programs are copyrighted and all rights are reserved by AeroComm, Inc. AeroComm, Inc. reserves the right to make periodic modifications of this product without obligation to notify any person or entity of such revision. Copying, duplicating, selling, or otherwise distributing any part of this product or accompanying documentation/software without the prior consent of an authorized representative of AeroComm, Inc. is strictly prohibited.

All brands and product names in this publication are registered trademarks or trademarks of their respective holders.

This material is preliminary

Information furnished by AeroComm in this specification is believed to be accurate. Devices sold by AeroComm are covered by the warranty and patent indemnification provisions appearing in its Terms of Sale only. AeroComm makes no warranty, express, statutory, and implied or by description, regarding the information set forth herein. AeroComm reserves the right to change specifications at any time and without notice.

AeroComm's products are intended for use in normal commercial and industrial applications. Applications requiring unusual environmental requirements such as military, medical life-support or life-sustaining equipment are specifically not recommended without additional testing for such application.

Limited Warranty, Disclaimer, Limitation of Liability

For a period of one (1) year from the date of purchase by the OEM customer, AeroComm warrants the OEM transceiver against defects in materials and workmanship. AeroComm will not honor this warranty (and this warranty will be automatically void) if there has been any (1) tampering, signs of tampering; 2) repair or attempt to repair by anyone other than an AeroComm authorized technician.

This warranty does not cover and AeroComm will not be liable for, any damage or failure caused by misuse, abuse, acts of God, accidents, electrical irregularity, or other causes beyond AeroComm's control, or claim by other than the original purchaser.

In no event shall AeroComm be responsible or liable for any damages arising: From the use of product; From the loss of use, revenue or profit of the product; or As a result of any event, circumstance, action, or abuse beyond the control of AeroComm, whether such damages be direct, indirect, consequential, special or otherwise and whether such damages are incurred by the person to whom this warranty extends or third party.

If, after inspection, AeroComm determines that there is a defect, AeroComm will repair or replace the OEM transceiver at their discretion. If the product is replaced, it may be a new or refurbished product.

<u>Revision</u>	<u>Description</u>
Version 1.0	3/15/02 - Initial Release Version
Version 1.1	12/18/02 - Preliminary Release
Version 1.2	12/20/02 - Preliminary Release. Changed location of new interface pins for higher compatibility with AC4424 family.
Version 1.3	1/29/03 - Updated interface baud rate formula/table. Updated current consumption table. Corrected RSSI plot. Updated interface timeout information. Renamed product family to AC4490. Multiple EEPROM read/write now allowed.
Version 1.4	2/18/03 - Added Max Power Byte. Removed Write Enable references. Fixed Power Down/Up command response. Removed peer-to-peer bit. Added Auto Destination. Added unicast only bit. Added 500 mW product. Revised part numbers. Updated channel number settings.
Version 1.5	Not released.
Version 1.6	11/07/03 - Added One beacon and modem modes. Included AC4486 product line. Added 500 mW specifications. Updated part numbers. Added AT Commands. Eliminated Commercial designation; All transceivers are now Industrial qualified.
Version 1.7	7/9/04 - Changed Range Refresh so 0x00 is an invalid setting. Updated AC4490-500 output power. Added warranty information. Updated part numbers. Removed support of One Beacon mode. Added DES.
Version 1.8	1/03/04 - Changed minimum timeout at 19,200 to 3. Added support for One Beacon mode. Changed voltage requirements for -200. Added on the fly read temperature and EEPROM read/write commands. Removed AC4486 product information. Added Auto Channel.
Version 1.9	7/29/05 - Removed documentation for static commands. Added Australian channels. Added CC 26 command. Updated mechanical drawing for MMXC version. Included new RSSI table. Added 1x1 documentation. Added Protocol Status, Received Acknowledgement, and Receive API modes.
Version 2.0	9/06/05 - Added Appendix 1 - Sample Power Supply
Version 2.1	10/06/05 - Added CC 27 command. Added Long Range mode. Added EEPROM write warning.
Version 2.2	11/08/05 - Removed CC 27 command. Removed Long Range mode. Corrected RS-485 DE Control.
Version 2.3	12/20/05 - Removed stream mode documentation. Added Enhanced API commands. Updated Australian channels.
Version 2.4	Not released.
Version 2.5	7/03/06 - Removed sub hop adjust documentation. Removed Configuration Mode documentation. Added Probe command. Added Max Power Backup byte (address 0x8E). Added Product ID bytes (addresses 0x90 - 0x9F). Changed default Enhanced API value to 0xF8. Added Serial Communications documentation. Added 4490LR-200 documentation. Updated ording information and product tree. Added Appendix II - 5V to 3.3V levels. Added Appendix III - API. Added Appendix IV - Sync to Channel.

DOCUMENT INFORMATION

<u>Revision</u>	<u>Description</u>
Version 2.6	7/13/06 - Added AC4490LR-1000 documentation. Added Long Range documentation and EEPROM parameters. Removed Read/Write API Control Commands. Updated ordering information and product tree.
Version 2.7	8/3/06 - Added Table of Contents.
Version 2.8	10/16/06 - Updated Approved Antenna List.
Version 2.9	1/9/07 - Updated Approved Antenna List. Updated Agency Identification numbers.
Version 3.0	2/1/07 - Added CMD/Data RX disable and RS485 Modem Modes. Added Industrial Temperature enhancement information and commands. Changed range refresh definition for servers with sync-to-channel enabled and updated sync-to-channel information.
Version 3.1	7/8/07 - Updated Approved Antenna List. Updated Agency Identification numbers.

AC4490 TRANSCEIVER MODULE

1

The compact AC4490 900MHz transceiver can replace miles of cable in harsh industrial environments. Using field-proven FHSS technology which needs no additional FCC licensing in the Americas, OEMs can easily make existing systems wireless with little or no RF expertise.

AC4490 FEATURES

NETWORKING AND SECURITY

- Drop-in replacement for AC4424 2.4 GHz product family
- Generic I/O digital lines and integrated DAC/ADC functions
- Retries and Acknowledgements
- API Commands to control packet routing and acknowledgement on a packet-by-packet basis
- Frequency Hopping Spread Spectrum for security and interference rejection
- Customizable RF Channel number and system ID
- Dynamic link analysis, remote radio discovery
- Low latency and high throughput
- Hardware Protocol Status monitoring

EASY TO USE

- Continuous 76.8 kbps RF data stream
- Software selectable interface baud rates from 1200 bps to 115.2 kbps
- Low cost, low power and small size ideal for high volume, portable and battery powered applications
- All modules are qualified for Industrial temperatures (-40°C to 80°C)
- Advanced configuration available using AT commands

OVERVIEW

The AC4490 is a member of AeroComm's ConnexRF OEM transceiver family. The AC4490 is a cost effective, high performance, frequency hopping spread spectrum transceiver; designed for integration into OEM systems operating under FCC part 15.247 regulations for the 900 MHz ISM band.

AC4490 transceivers provide an asynchronous TTL/RS-485 level serial interface for OEM Host communications. Communications include both system and configuration data. The Host supplies system data for transmission to other Host(s). Configuration data is stored in the on-board EEPROM. All frequency hopping, synchronization, and RF system data transmission/reception is performed by the transceiver.

To boost data integrity and security, the AC4490 uses AeroComm's field-proven FHSS technology featuring optional Data-Encryption Standards (DES). Fully transparent, these transceivers operate seamlessly in serial cable replacement applications.

AC4490 transceivers can operate in a Point-to-Point, Point-to-Multipoint, Client-Server, or Peer-to-Peer architecture. One transceiver is configured as a Server and there can be one or many Clients. To establish synchronization between transceivers, the Server emits a beacon. Upon detecting a beacon, the Client transceiver informs its Host and an RF link is established.

This document contains information about the hardware and software interface between an AeroComm AC4490 transceiver and an OEM Host. Information includes the theory of operation, specifications, interface definition, configuration information and mechanical drawings. The OEM is responsible for ensuring the final product meets all appropriate regulatory agency requirements listed herein before selling any product.

Note: Unless mentioned specifically by name, the AC4490 modules will be referred to as the “radio” or “transceiver”. Individual naming is used to differentiate product specific features. The host (PC/Microcontroller/Any device to which the AC4490 module is connected) will be referred to as “OEM Host”.



SPECIFICATIONS

2

Table 1: AC4490 Specifications

General																																				
20 Pin Interface Connector	Molex 87759-0030, mates with Samtec SMM-110-02-S-D																																			
RF Connector	Johnson Components 135-3711-822																																			
Antenna	AC4490-1x1: Customer must provide AC4490-200: MMCX Connector or integral antenna AC4490-1000: MMCX Connector																																			
Serial Interface Data Rate	Baud rates from 1200 bps to 115,200 bps																																			
Power Consumption (typical)	<table border="1"> <thead> <tr> <th></th> <th colspan="6">Duty Cycle (TX=Transmit; RX=Receive)</th> </tr> <tr> <th></th> <th>10%TX</th> <th>50%TX</th> <th>100%TX</th> <th>100%RX</th> <th>Pwr-Down</th> <th>Deep Sleep</th> </tr> </thead> <tbody> <tr> <td>1x1:</td> <td>33mA</td> <td>54mA</td> <td>80mA</td> <td>28mA</td> <td>15mA</td> <td>3mA</td> </tr> <tr> <td>200:</td> <td>38mA</td> <td>68mA</td> <td>106mA</td> <td>30mA</td> <td>19mA</td> <td>6mA</td> </tr> <tr> <td>1000:</td> <td>130mA</td> <td>650mA</td> <td>1300mA</td> <td>30mA</td> <td>19mA</td> <td>6mA</td> </tr> </tbody> </table>		Duty Cycle (TX=Transmit; RX=Receive)							10%TX	50%TX	100%TX	100%RX	Pwr-Down	Deep Sleep	1x1:	33mA	54mA	80mA	28mA	15mA	3mA	200:	38mA	68mA	106mA	30mA	19mA	6mA	1000:	130mA	650mA	1300mA	30mA	19mA	6mA
	Duty Cycle (TX=Transmit; RX=Receive)																																			
	10%TX	50%TX	100%TX	100%RX	Pwr-Down	Deep Sleep																														
1x1:	33mA	54mA	80mA	28mA	15mA	3mA																														
200:	38mA	68mA	106mA	30mA	19mA	6mA																														
1000:	130mA	650mA	1300mA	30mA	19mA	6mA																														
Channels	3 Channel Sets comprising 56 total channels																																			
Security	One byte System ID. 56-bit DES encryption key.																																			
Interface Buffer Size	Input/Output:256 bytes each																																			
Transceiver																																				
Frequency Band	902 – 928 MHz																																			
RF Data Rate	76.8 kbps fixed																																			
RF Technology	Frequency Hopping Spread Spectrum																																			
Output Power	<table border="1"> <thead> <tr> <th></th> <th>Conducted (no antenna)</th> <th>EIRP (3dBi gain antenna)</th> </tr> </thead> <tbody> <tr> <td>AC4490-1x1:</td> <td>10mW typical</td> <td>20mW typical</td> </tr> <tr> <td>AC4490-200:</td> <td>100mW typical</td> <td>200mW typical</td> </tr> <tr> <td>AC4490-1000:</td> <td>743mW typical</td> <td>1486mW typical</td> </tr> </tbody> </table>		Conducted (no antenna)	EIRP (3dBi gain antenna)	AC4490-1x1:	10mW typical	20mW typical	AC4490-200:	100mW typical	200mW typical	AC4490-1000:	743mW typical	1486mW typical																							
	Conducted (no antenna)	EIRP (3dBi gain antenna)																																		
AC4490-1x1:	10mW typical	20mW typical																																		
AC4490-200:	100mW typical	200mW typical																																		
AC4490-1000:	743mW typical	1486mW typical																																		
Supply Voltage	<p>AC4490-1x1: 3.3V, ±50mV ripple AC4490-200: 3.3 – 5.5V, ±50mV ripple AC4490-1000*: Pin 10: 3.3 – 5.5V ±50mV ripple Pin 11: 3.3 ±3%, ±100mV ripple</p> <p>* Pins 10 and 11 may be tied together, provided the supply voltage never falls below 3.3 V and is capable of supplying 1.5 A of current. Pins 10 & 11 are internally connected on the AC4490-200 only.</p>																																			
Sensitivity	-100dBm typical @ 76.8kbps RF Data Rate																																			
	-110dBm typical @ 76.8kbps RF Data Rate (AC4490LR-200/-1000)																																			
EEPROM write cycles	20000																																			
Hop period	20 ms																																			

Table 1: AC4490 Specifications

Transceiver (Cont'd)			
Range, Line of Site (based on 3dBi gain antenna)	AC4490-1x1:	Up to 1 mile	
	AC4490-200:	Up to 4 miles	
	AC4490LR-200:	Up to 8 miles	
	AC4490-1000:	Up to 20 miles	
	AC4490LR-1000:	Up to 40 miles	
Environmental			
Temperature (Operating)	-40°C to 80°C		
Temperature (Storage)	-50°C to +85°C		
Humidity (non-condensing)	10% to 90%		
Physical			
Dimensions	Transceiver with MMCX Connector: 1.65" x 1.9" x 0.20" Transceiver with Integral Antenna: 1.65" x 2.65" x 0.20" AC4490-1x1: 1.00" x 1.00" x 0.162"		
Certifications			
	AC4490-200A	AC4490-200/AC4490LR-200	AC4490-1000
FCC Part 15.247	KQLAC4490-100	KQL-4x90200	KQLAC4490
Industry Canada (IC)	2268C-AC4490	2268C-4x90200	2268C-AC44901000

PIN DEFINITIONS

The AC4490 has a simple interface that allows OEM Host communications with the transceiver. The table below shows the connector pin numbers and associated functions. The I/O direction is with respect to the transceiver. All outputs are 3.3VDC levels and inputs are 5VDC TTL (with the exception of AC4490-1x1 and AC4490-1000 transceivers which have 3.3V inputs). All inputs are weakly pulled High and may be left floating during normal operation (with the exceptions listed for the AC4490-1x1).

Table 2: AC4490 Pin Definitions

Module Pin	1x1 Pin	Type	Signal Name	Function
1	4	O	GO0	Generic Output pin
2	6	O	TXD	Transmitted data out of the transceiver
		I/O	RS485 A (True) ¹	Non-inverted RS-485 representation of serial data
3	7	I	RXD	Data input to the transceiver
		I/O	RS485 B (Invert) ¹	Mirror image of RS-485 A



Table 2: AC4490 Pin Definitions

Module Pin	1x1 Pin	Type	Signal Name	Function
4	5 ²		GI0	Generic Input pin
5	3	GND	GND	Signal Ground
6		O	Hop Frame	Pulses low when the transceiver is hopping frequencies.
7	9	O	CTS	Clear to Send – Active Low when the transceiver is ready to accept data for transmission.
8	10 ²	I	RTS	Request to Send – When enabled in EEPROM, the OEM Host can take this High when it is not ready to accept data from the transceiver. NOTE: Keeping RTS High for too long can cause data loss.
9	19	O	GO1	Generic Output pin
10	2	PWR	VCC1	AC4490-1x1: 3.3V, ±50mV ripple AC4490-200: 3.3 – 5.5V, ±50mV ripple (Pin 10 is internally connected to Pin 11) AC4490-1000: 3.3 – 5.5V, ±50mV ripple
11	11	PWR	VCC2	AC4490-1x1: 3.3V, ±50mV ripple AC4490-200: 3.3 – 5.5V, ±50mV ripple (Pin 11 is internally connected to Pin 10) AC4490-1000: 3.3V ±3%, ±100mV ripple
12	23	I	Test	Test Mode – When pulled logic Low and then applying power or resetting, the transceiver's serial interface is forced to a 9600, 8-N-1 rate. To exit, the transceiver must be reset or power-cycled with Test Mode logic High.
13	12	O	RSSI	Received Signal Strength - An analog output giving an instantaneous indication of received signal strength. Only valid while in Receive Mode.
14	21 ²	I	GI1	Generic Input pin
15	16	I	UP_RESET	RESET – Controlled by the AC4490 for power-on reset if left unconnected. After a stable power-on reset, a logic High pulse will reset the transceiver.
16	13	GND	GND	Signal Ground
17	17	I	CMD/Data	When logic Low, the transceiver interprets OEM Host data as command data. When logic High, the transceiver interprets OEM Host data as transmit data.
18	15 ³	I	AD In	10 bit Analog Data Input
19	20 ⁴	O	DA_Out	10 bit Analog Data Output
20	18	O	In_Range	When logic Low, a Client is in range of a Server on same Channel and System ID. Always low on a Server radio.
N/A	14	RF	RF Port	RF Interface
N/A	22	I	Reset	Active Low version of UP_RESET. If RESET is used, UP_RESET should be left floating and if UP_RESET is used, RESET should be left floating.

1. When ordered with a RS-485 interface (not available on the AC4490-1x1).
2. Must be tied to VCC or GND if not used. Should never be permitted to float.
3. If used, requires a shunt 0.1µF capacitor at pin 15 followed by a series 1k resistor.
4. If used, requires a series 1k resistor at pin 20 followed by a shunt 0.1µF capacitor.

ELECTRICAL SPECIFICATIONS

Table 3: Input Voltage Characteristics

Signal Name	AC44901x1 / AC4490-1000M				AC4490-200X				Unit
	High Min.	High Max.	Low Min.	Low Max.	High Min.	High Max.	Low Min.	Low Max.	
RS485A/B	N/A	12	-7	N/A	N/A	12	-7	N/A	V
RXD	2.31	3.3	0	0.99	2	5.5	0	0.8	V
GI0	2.31	3.3	0	0.99	2	5.5	0	0.8	V
RTS	2.31	3.3	0	0.99	2	5.5	0	0.8	V
$\overline{\text{Test}}$	2.31	3.3	0	0.99	2	5.5	0	0.8	V
GI1	2.31	3.3	0	0.99	2	5.5	0	0.8	V
UP_RESET	0.8	3.3	0	0.6	0.8	5	0	0.6	V
Command/Data	2.31	3.3	0	0.99	2	5.5	0	0.8	V
AD In	N/A	3.3	0	N/A	N/A	3.3	0	N/A	V

Table 4: Output Voltage Characteristics

Signal Name	Module Pin	1x1 Pin	Type	High Min.	Low Max.	Unit
GO0	1	19	O	2.5 @ 8mA	0.4 @ 8mA	V
TXD	2	6	O	2.5 @ 2mA	0.4 @ 2mA	V
RS485A/B	2,3	N/A	I/O	3.3 @ 1/8 Unit Load	N/A	V
Hop Frame	6	1	O	2.5 @ 2mA	0.4 @ 2mA	V
CTS	7	9	O	2.5 @ 2mA	0.4 @ 2mA	V
GO1	9	19	O	2.5 @ 2mA	0.4 @ 2mA	V
RSSI	13	12	O	See Figure 1	See Figure 1	V
DA_Out	19	20	O	N/A	N/A	V ¹
In Range	20	18	O	2.5 @ 2mA	0.4 @ 2mA	V

1. DA_Out is an unbuffered, high impedance output and must be buffered by the OEM Host when used.

THEORY OF OPERATION

RF ARCHITECTURE

The AC4490 utilizes a Server-Client network where all Clients synchronize their hopping to the Server. The Server transmits a beacon during the first 1 ms of every hop (20 ms). The Client transceivers listen for this beacon and upon hearing it assert their In_Range Low and synchronize their hopping with the Server.

Each network should consist of only one Server and there should never be two servers on the same RF Channel number in the same coverage area as the interference between the two servers will severely hinder RF communications. For those applications requiring collocated servers, Aerocomm recommends using the Sync-to-Channel feature which is further explained in the Sync-to-Channel Appendix.

MODES OF OPERATION

The AC4490 has three different operating modes; Receive, Transmit, & Command Mode. If the transceiver is not communicating with another radio, it will be in Receive Mode actively listening for a beacon from the Server. If the Client determines that the beacon is from a server operating on the same RF Channel and System ID, it will respond by asserting In_Range Low. A transceiver will enter Transmit or Command mode when the OEM Host sends data over the serial interface. The state of the Command/Data pin (Pin 17) or the data contents determine which of the two modes will be entered.

Transmit Mode

All packets sent over the RF are either Addressed or Broadcast packets. Broadcast and Addressed delivery can be controlled dynamically with the API Control byte and corresponding on-the-fly commands. To prohibit transceivers from receiving broadcast packets, Unicast only can be enabled.

ADDRESSED PACKETS

When sending an addressed packet, the RF packet is sent only to the receiver specified in destination address. To increase the odds of successful delivery, Transmit retries are utilized. transparent to the OEM Host; the sending radio will send the RF packet to the intended receiver. If the receiver receives the packet free of errors, it will return an RF acknowledge within the same 20 ms hop. If a receive acknowledgement is not received, the radio will use a transmit retry to resend the packet. The radio will continue sending the packet until either (1) an acknowledgement is received or (2) all transmit retries have been used. The received packet will only be sent to the OEM Host if and when it is received free of errors.

BROADCAST PACKETS

When sending a broadcast packet, the RF packet is sent out to every eligible transceiver on the network. To increase the odds of successful delivery, Broadcast attempts are utilized. Transparent to the OEM Host, the sending radio will send the RF packet to the intended receiver(s). Unlike transmit retries, all broadcast attempts are used; regardless of when the RF packet is actually received and without RF acknowledgements. If the packet is received on the first attempt, the receiver will ignore the remaining broadcast attempts. The received packet will only be sent to the OEM Host if and when it is received free of errors.

Receive Mode

When a transceiver is not in Transmit or Command mode, it will be in Receive Mode listening for data. While in Receive Mode, subsequent data of up to 80 bytes can be received every hop (20 ms).

Command Mode

A radio will enter Command Mode when data is received over the serial interface from the OEM Host and either the Command/Data pin (pin 17) is logic Low or the received data contains the “AT+++” (Enter AT Command Mode) command. Once in Command Mode, all data received by the radio is interpreted as command data. Command Data can be either EEPROM Configuration or On-The-Fly commands.

Figure 1: Pending RF and Data in Buffer Flow

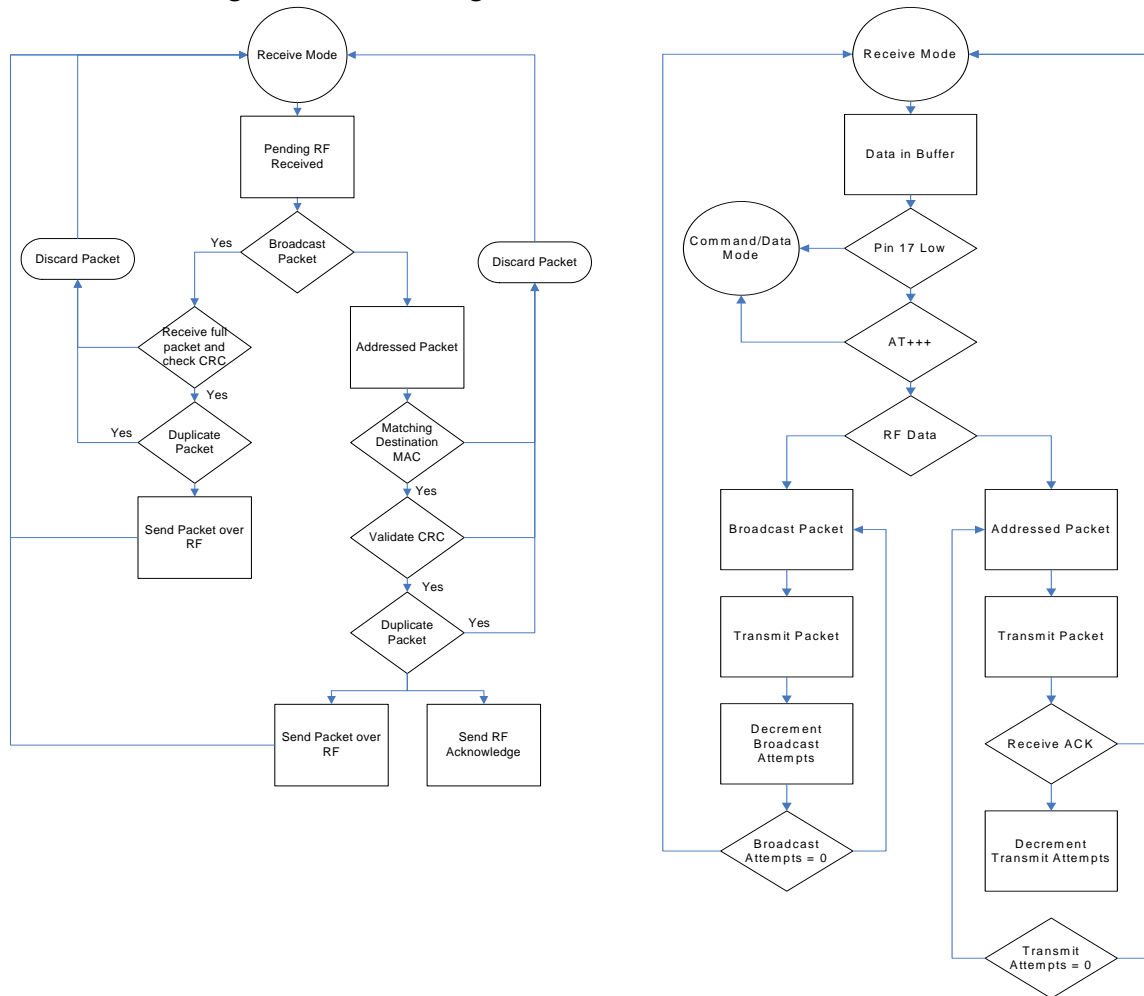

API CONTROL

API Control is a powerful feature that the AC4490 offers. When enabled, the API Receive Packet, API Transmit Packet, API Send Data Complete and Enhanced API Receive Packet features provide dynamic packet routing and packet accounting ability to the OEM Host, thereby eliminating the need for extensive programming on the OEM Host side. This ability of the protocol makes it ideal for any legacy system. API operation utilizes specific packet formats;

specifying various vital parameters used to control radio settings and packet routing on a packet-by-packet basis. The API features can be used in any combination that suits the OEM's specific needs.

Receive API Packet

Implemented in v6.3 of the firmware and later. Receive API Packet can be enabled to determine the sender of a message. This causes the radio to append a header to the received packet detailing the length of the data packet and the sender's MAC address. The Receive API Packet will follow the following format.

0x83	Payload Data Length	Sender's MAC	Payload Data
------	---------------------	--------------	--------------

API Transmit Packet

Implemented in v6.7 of the firmware and later. API Transmit Packet is a powerful command that allows the OEM Host to send data to a single or multiple (broadcast) transceivers on a packet-by-packet basis. This can be useful for many applications; including polling and/or mesh networks. Refer to the API Appendix for further details.

API Transmit Packet is enabled when bit-1 of the Enhanced API Control byte is enabled. The OEM Host should use the following format to transmit a packet over the RF.

0x81	Payload Data Length (0x01 - 0x80)	Aerocomm Use	Transmit Retries/Broadcast Attempts	Destination MAC (2,1,0)	Payload Data
------	-----------------------------------	--------------	-------------------------------------	-------------------------	--------------

- 1 If the OEM Host does not encode the header correctly, the transceiver will send the entire string (up to 80 bytes) and will look for the header in the next data.**
- 2 Although the 7 bytes of overhead are not sent over the RF, they are kept in the buffer until the packet is sent. Keep this in mind so as not to overrun the 256-byte buffer.**
- 3 Setting the MAC to 0xFF 0xFF 0xFF will broadcast the packet to all available transceivers.**

API Send Data Complete

Implemented in v6.7 of the firmware and later. API Send Data complete can be used as a software acknowledgement indicator. When a radio sends an addressed packet, it will look for a received acknowledgement (transparent to OEM Host). If an acknowledgement is not received, the packet will be retransmitted until one is received or all retries have been used.

API Send Data Complete is enabled when bit-2 of the Enhanced API Control byte is enabled. The transceiver sends the OEM Host the following data upon receiving an RF acknowledge or exhausting all attempts.

0x82	Aerocomm Use	RSSI*	0x00: Failure 0x01: Success
------	--------------	-------	--------------------------------

- 1 RSSI* is how strong the local transceiver heard the remote transceiver.**
- 2 Successful RF Acknowledge updates the Success/Failure bit.**
- 3 A success will always be displayed when sending broadcast packets after all broadcast attempts have been exhausted.**

API Receive Packet

Implemented in v6.7 of the firmware and later. By default, the source MAC is not included in the received data string sent to the OEM Host. For applications where multiple radios are sending data, it may be necessary to determine the origin of a specific data packet. When API Receive Packet is enabled, all packets received by the transceiver will

include the MAC address of the source radio as well as an RSSI indicator which can be used to determine the link quality between the two.

API Receive Packet is enabled when bit-0 of the Enhanced API Control byte is enabled. Upon receiving a packet the radio sends its OEM Host the packet in the following format:

0x81	Payload Data Length (0x01 - 0x80)	Aerocomm Use	RSSI*	Source MAC (2,1,0)	Payload Data
------	--------------------------------------	--------------	-------	-----------------------	--------------

ENGINEER'S TIP

When both API Send Data Complete and API Receive Packet are enabled, the Send Data Complete will be received before the transceiver sees the Receive API Packet. This order may get reversed when the API Send Data Complete is missed and is being resent after the API Receive Packet is received.

Note: If Enhanced Receive API is enabled, the Receive API feature should be disabled by setting EEPROM byte 0xC1 to 0xFF.

PROTOCOL STATUS/RECEIVE ACKNOWLEDGEMENT

Implemented in v6.3 of the firmware and later. When enabled in EEPROM, GO0 and GO1 will perform the functions of Protocol Status and Receive Acknowledgement.

Protocol Status

Every time the radio hops to hop bin 0, the radios will assert GO0 Low for the entire hop bin. GO0 will go Low at the falling edge of the Hop Frame at the start of bin 0 and will go High with the rising edge of Hop Frame at the end of bin 0. During all other hops, GO0 will be high. **This mode is incompatible with modem mode.**

Receive Acknowledgement

The radio uses GO1 to signal that a valid RF acknowledgement has been received from the remote radio. GO1 is normally Low and will go High within approximately 75 us of receiving a valid RF acknowledgement. It will remain High until the end (rising edge) of the next hop. **This mode is incompatible with Modem mode.**

LONG RANGE MODE

Specific to the AC4490LR-200 and AC4490LR-1000 transceivers, Long Range mode increases the receiver sensitivity and range of the radio when enabled in EEPROM. Under some circumstances, such as in areas with extremely high interference levels, Long Range Mode may provide unsatisfactory results. In such cases, normal radio operation can be achieved by disabling Long Range Mode; either temporarily using CC Commands or permanently by writing to the EEPROM.



Note: Long Range Mode is only available on the AC4490LR-200 and AC4490LR-1000 transceivers with the following board revisions and firmware v6.7+.

Table 5: Long Range Requirements

Module	Board Number	Board Revision
AC4490LR-200	0050-00100	Rev. 1 and higher
AC4490LR-1000	0050-00102	Rev. 1 and higher

SERIAL INTERFACE

In order for the OEM Host and a transceiver to communicate over the serial interface they need to have the same serial data rate. Refer to the following sections to ensure that the OEM Host data rate matches the serial interface baud rate.

SERIAL COMMUNICATIONS

The AC4490 is a TTL device which can be interfaced to a compatible UART (microcontroller) or level translator to allow connection to serial devices. UART stands for Universal Asynchronous Receiver Transmitter and its main function is to transmit or receive serial data.

Asynchronous Operation

Since there is no separate clock in asynchronous operation, the receiver needs a method of synchronizing with the transmitter. This is achieved by having a fixed baud rate and by using START and STOP bits. A typical asynchronous mode signal is shown below.

Figure 2: Asynchronous Mode Signal

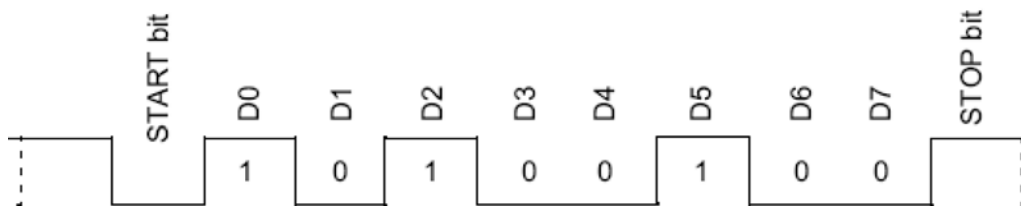

The UART outputs and inputs logic level signals on the TX and RX pins. The signal is high when no data is being transmitted and goes low when transmission begins.

The signal stays low for the duration of the START bit and is followed by the data bits; LSB first. The STOP bit follows the last data bit and is always high. After the STOP bit has completed, the START bit of the next transmission can occur.

Parity

A parity bit is used to provide error checking for a single bit error. When a single bit is used, parity can be either even or odd. Even parity means that the number of ones in the data and parity sum to an even number and vice-versa. The ninth data bit can be used as a parity bit if the data format requires eight data bits and a parity bit as shown below.

Figure 3: Even Parity Bit

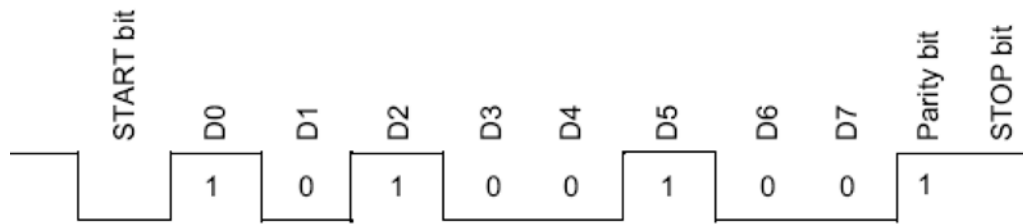

Note: Enabling parity cuts throughput and the interface buffer in half.

OEM HOST DATA RATE

The OEM Host Data Rate is the rate with which the OEM Host and transceiver communicate over the serial interface. This rate is independent of the RF baud rate, which is fixed at 76.8 kbps. Possible values range from 1200 bps to 115,200 bps. Note: Enabling Parity cuts throughput in half and the Interface Buffer size in half. The following asynchronous serial data formats are supported:

Table 6: Supported Serial Formats

Data Bits	Parity	Stop Bits	Transceiver Programming Requirements
8	N	1	Parity Disabled
7	N	2	Parity Disabled
7	E, O, M, S	1	Parity Disabled
9	N	1	Parity Enabled
8	N	2	Parity Enabled
8	E, O, M, S	1	Parity Enabled
7	E, O, M, S	2	Parity Enabled

Mark (M) corresponds to 1 & Space (S) corresponds to 0

SERIAL INTERFACE BAUD RATE

This two-byte value determines the baud rate used for communicating over the serial interface to a transceiver. The Table below lists values for some common baud rates. Baud rates below 1200 baud are not supported. For a baud rate to be valid, the calculated baud rate must be within $\pm 3\%$ of the OEM Host baud rate. If the Test pin (Pin 12) is pulled logic Low at reset, the baud rate will be forced to 9,600. The RF baud rate is fixed at 76.8 Kbps and is independent of the interface baud rate. For Baud Rate values other than those shown below, the following equations can be used:

$$\text{BAUD} = \frac{14.7456 \times 10^6}{64 \times \text{DesiredBaud}}$$

BaudH = Always 0

BaudL = Low 8 bits of BAUD (base 16)

Table 7: Baud Rate / Interface Timeout

Baud Rate	BaudL (0x42)	BaudH (0x43)	Minium Interface Timeout (0x58)	Stop Bit Delay (0x3F)
115,200	0xFE	0x00	0x02	0xFF
57,600 ¹	0xFC	0x00	0x02	0x03
38,400	0xFA	0x00	0x02	0x08
28,800	0xF8	0x00	0x02	0x0E
19,200	0xF4	0x00	0x03	0x19
14,400	0xF0	0x00	0x04	0x23
9,600	0xE8	0x00	0x05	0x39
4800	0xD0	0x00	0x09	0x7A
2400	0xA0	0x00	0x11	0xFC
1200	0x40	0x00	0x21	0x00 ²

1. 57,600 is the default baud rate

2. 0x00 will yield a stop bit of 421 uS. The stop bit at 1200 baud should actually be 833 uS.

INTERFACE TIMEOUT / RF PACKET SIZE

Interface Timeout (EEPROM address 0x58), in conjunction with **RF Packet Size** (EEPROM address 0x5B), determines when a buffer of data will be sent out over the RF as a complete RF packet, based on whichever condition occurs first.

Interface Timeout – Interface Timeout specifies a maximum byte gap between consecutive bytes. When that byte gap is exceeded, the bytes in the transmit buffer are sent out over the RF as a complete packet. Interface Timeout is adjustable in 0.5ms increments and has a tolerance of ± 0.5 ms. Therefore, the Interface Timeout should be set to a minimum of 2. The default value for Interface Timeout is 0x04 (2ms) and should be adjusted accordingly when changing the transceiver baud rate.

RF Packet Size – When the number of bytes in the transceiver transmit buffer equals RF Packet Size, those bytes are sent out as a complete RF packet. It is much more efficient to send a few large packets rather than several short packets as every packet the transceiver sends over the RF contains extra header bytes which are not included in the RF Packet Size. RF packet size can be set to a maximum of 0x50 (80 bytes) and must be set to a minimum of 0x06 in order to send the Enter AT Command mode command. To change the RF packet size from the default value, Auto Config must be disabled and the appropriate Auto Config parameters must be changed.



FLOW CONTROL

Flow control refers to the control of data flow between transceivers. It is the method used to handle data in the transmit/receive buffer and determines how data flow between the transceivers is started and stopped. Often, one transceiver is capable of sending data much faster than the other can receive and flow control allows the slower device to tell the faster device when to pause and resume data transmission.

When a transceiver has data to send, it sends a Ready To Send signal and waits for a Clear To Send response from the receiving unit. If the receiving radio is ready to accept data it will assert its $\overline{\text{CTS}}$ low. $\overline{\text{CTS}}$ will be reasserted when the buffer contains the number of bytes specified by CTS_OFF (EEPROM address 0x5D). These signals are sent apart from the data itself on separate wires.

ENGINEER'S TIP

Can I implement a design using just Txd, Rxd and Gnd (Three-wire Interface)?

Yes. However, it is strongly recommended that your hardware monitor the CTS pin of the radio. CTS is taken High by the radio when its interface buffer is getting full. Your hardware should stop sending at this point to avoid a buffer overrun (and subsequent loss of data).

You can perform a successful design without monitoring CTS. However, you need to take into account the amount of latency the radio adds to the system, any additional latency caused by Transmit Retries or Broadcast Attempts, how often you send data, non-delivery network timeouts and interface data rate. Polled type networks, where the Server host requests data from the Client host and the Client host responds, are good candidates for avoiding the use of CTS. This is because no one transceiver can monopolize the RF link. Asynchronous type networks, where any radio can send to another radio at any point in time, are much more difficult to implement without the use of CTS.

HALF DUPLEX / FULL DUPLEX

When Half Duplex communication is chosen, the AC4490 will send a packet out over the RF whenever it can. This can cause packets sent by multiple transceivers at the same time to collide with each other over the RF. To prevent this, Full Duplex communication can be chosen. Full Duplex shares the bandwidth intelligently to enable two-way collision-free communication without any collision. This is done by calculating the amount of time until the next hop to ensure that it has time to send the packet; if there is enough time, it will send the packet and if not, it will wait until its next appropriate hop. The Server transmits during the even hops while the Client(s) will transmit during the odd hops. Although the RF hardware is still technically half duplex, the bandwidth sharing it makes the transceiver seem full duplex. Enabling Full Duplex can cause overall throughputs to be cut in half.

SYSTEM TIMING & LATENCY

Care should be taken when selecting transceiver architecture, as it can have serious effects on data rates, latency, and overall system throughput. The importance of these three characteristics will vary from system to system and

should be a strong consideration when designing the system.

ENGINEER'S TIP

In High-density applications, what amount of latency should be expected?

It is not easy to predict the exact amount of latency in high-density applications. There are many variables that affect system latency. The three variables that most affect the latency are the network load, the distance between transceivers, and whether the transceivers are operating in a broadcast or addressed mode. There is no fixed answer as to how much latency will be introduced in the system when considering high-density applications. In these cases we can just offer qualitative analysis of the latency in high-density applications. As the network load increases, then the number of collisions that will occur increases. As the number of collisions increase, then the system latency increases. As the distance between the transceivers increases, so to does the system latency. Finally, when transceivers operate in addressed mode they will retry sending a packet up to the number of time specified in the transmit retry parameter specified in the EEPROM. As the number of retries increases, the system latency will increase also.

SYSTEM THROUGHPUT

When operating as shown below, an AC4490 transceiver is capable of achieving the listed throughput. However, in the presence of interference or at longer ranges, the transceiver may be unable to meet the specified throughput.

Table 8: Maximum System Throughput

One Beacon Mode	Parity Mode	Half Duplex Throughput (bps)	Full Duplex Throughput (bps) each way
Disabled	Disabled	38k	19k
Enabled	Disabled	48k	24k
Disabled	Enabled	19k	9.5k
Enabled	Enabled	24k	12k

SOFTWARE INTERFACE

NETWORKING

System ID - System ID (EEPROM address 0x76) is similar to a password character or network number and makes network eavesdropping more difficult. A transceiver will not establish a Session or communicate with a transceiver operating on a different System ID or Channel Number.

RF Channel Number - Channels 0x00 - 0x0F and 0x30 - 0x37 hop on 26 different frequencies. Channels 0x10 - 0x2F use 50 different frequencies.

Table 9: RF Channel Number Settings

Channel Set ¹	RF Channel Number Range (0x40)	Frequency Details & Regulatory requirements	Countries
0 (AC4490 - 1x1 AC4490 - 200)	0x00 - 0x0F	902 - 928 MHz (26 hop bins)	US / Canada
1 (AC4490 - 1x1 AC4490 - 1000)	0x10 - 0x2F	902 - 928 MHz (50 hop bins)	US / Canada
2 (AC4490 - 1x1 AC4490 - 200 AC4490 - 1000)	0x30 - 0x37	915 - 928 MHz (22 hop bins)	US / Canada (-1x1 / -200) Australia(-1x1/-200/-1000)

1. All Channels in a Channel Set use the same frequencies in a different order.

Auto Channel - To allow for more flexible network configurations, Auto Channel can be enabled on Client transceivers to allow them to automatically synchronize with the first Server they hear a beacon from, regardless of the Server's Channel Number or signal strength. **Note:** A Client with Auto Channel enabled will only synchronize with a Server operating in the same Channel set and with the same System ID.

DES (Data Encryption Standard) - DES (Data Encryption Standard) – Encryption is the process of encoding an information bit stream to secure the data content. The DES algorithm is a common, simple and well-established encryption routine. An encryption key of 56 bits is used to encrypt the packet. The receiver must use the exact same key to decrypt the packet; otherwise garbled data will be produced.

To enable DES, EEPROM Byte 0x45, bit 6 must be set to a value of 1. To disable DES, set bit 6 to a value of 0. The 7 byte (56 bits) Encryption/Decryption Key is located in EEPROM Bytes 0xD0 – 0xD6. **It is highly recommended that this Key be changed from the default.**

Sync to Channel - The AC4490 is a frequency hopping transceiver with a fixed hopping sequence. Without synchronizing their frequency hopping, collocated systems on different channels can interfere with each other. To avoid this, sync-to-channel can be used to synchronize the collocated Servers. A Server transceiver with sync-to-channel enabled must have its Sync Channel set to another Server's RF Channel number. It is required that a Server with sync-to-channel enabled have its sync channel set to a value less than its RF Channel number. **Collocated networks using sync-to-channel must use the same channel set.**

Note: If Server A (with sync-to-channel enabled) cannot synchronize to Server B (on the sync channel), Server A will not be able to communicate with its Clients and must wait until it synchronizes with Server B (at which point In_Range

will be asserted), before establishing communications. Server B will not be affected and can communicate with its Clients.

Refer to the Sync-to-Channel Appendix for further details and sample configuration.

ONE BEACON MODE / RANGE REFRESH

One Beacon - The 4490 maintains synchronization by using the timing information in the Server's beacon. This beacon lasts approximately 1 ms and by default is sent by the Server at the beginning of every hop to the particular frequency that the Server is hopping on. If One Beacon mode is enabled, the 1 ms synchronization pulse is sent only once per complete hop cycle. For example, a Server operating in Channel Set 1 (channels 0x10 - 0x2F) hops on 50 frequencies at 20 ms per frequency. Assuming that the Client hears the beacon on the first attempt, it can take up to 1 second (50 hops x 20 ms per hop) for a Client to hear the beacon and report In_Range.

Using One Beacon mode can make initial synchronization take longer and can make communications more difficult if operating on the fringe but can increase net throughput.

Table 10: One Beacon Mode Settings

EEPROM Address	One Beacon Mode Enabled	One Beacon Mode Disabled
0x45	Set bit 7	Clear bit 7
0x3C	0x18	0x28
0x3D	Channels 0x10 - 0x2F: 0xC8 All other Channels: 0x68	0x18

Range Refresh - Range Refresh specifies the maximum amount of time a Client reports in range without having heard a beacon from the Server. Each time the Client hears a beacon, it resets its Range Refresh timer. If the timer reaches zero, the Client will go out of range, take its In_Range pin High and enter acquisition mode attempting to find the Server once again. The range refresh is equal to the hop period (20 ms) x Range refresh value.

Note: Range Refresh should not be set to 0x00.

AUTO CONFIG PARAMETERS

The AC4490 has several variables that vary by RF mode and architecture. By default, Auto Config is enabled and bypasses the values stored in EEPROM and uses predetermined values for the given operating mode. Below is a list of the variables controlled by Auto Config and their respective predetermined values. If Auto Config is disabled, these values **must** be programmed in the transceiver EEPROM for the corresponding mode of operation.

Table 11: Auto Config Parameters

Parameter	EEPROM Address	Default	One Beacon Mode Disabled	One Beacon Mode Enabled
	0x36	0x66	0xA0	0xA0
	0x47	0x0E	0x0E	0x0E
	0x48	0x90	0x90	0x90



Table 11: Auto Config Parameters

Parameter	EEPROM Address	Default	One Beacon Mode Disabled	One Beacon Mode Enabled
	0x4E	0x09	0x09	0x09
	0x53	0x80	0x80	0x80
	0x54	0x07	0x07	0x07
RF Packet Size	0x5B	0x46	0x50	0x68
CTS On	0x5C	0xD2	0xDC	0xDC
CTS Off	0x5D	0xAC	0xB0	0xB0
	0x5E	0x23	0x23	0x23
	0x5F	0x08	0x08	0x08

INTERFACE OPTIONS

Modem Mode

Full modem handshaking is supported by the AC4490 when enabled in EEPROM. Modem mode is incompatible with RS-485 DE. The line states are updated a maximum of once per 20 ms and only change when toggled by the appropriate line on the remote radio. Because Command/Data performs an alternate function when modem mode is enabled, on-the-fly CC Commands cannot be used and Configuration Mode is entered by forcing 9600 baud through the 9600_Baud pin (pin 12). Therefore, modem mode is disabled when the radio is forced to 9600 baud. Both modem interfaces are shown in the tables below.

Table 12: Transceiver Interface to DCE (Server)

DCE Pin Number	DCE Pin Name	Direction with respect to transceiver	AC4490 Pin Name	AC4490 Pin Number
1	DCD	In	GI1	14
2	RXD	In	RXD	3
3	TXD	Out	TXD	2
4	DTR	Out	GO0	1
5	GND	-	GND	5
6	DSR	In	Command/Data	17
7	RTS	Out	CTS	7
8	CTS	In	RTS	8
9	RI	In	GI0	4

Table 13: Transceiver Interface to DTE (Client)

DTE Pin Number	DTE Pin Name	Direction with respect to transceiver	AC4490 Pin Name	AC4490 Pin Number
1	DCD	Out	GO0	1
2	RXD	Out	TXD	2
3	TXD	In	RXD	3
4	DTR	In	GI0	4
5	GND	-	GND	5
6	DSR	Out	Hop Frame	6
7	RTS	In	RTS	7
8	CTS	Out	CTS	8
9	RI	Out	G01	9

RS-485 DE Control - When enabled in EEPROM, the transceiver will use the GO0 pin to control the DE pin on external RS-485 circuitry. If enabled, when the transceiver has data to send to the host, it will assert GO0 High, send the data to the Host and then take GO0 Low.

RS485 Modem Mode

This mode is only useful for customers that wish to use RS485 DE in conjunction with standard Modem Mode. When enabled in EEPROM in conjunction with Modem Mode, allows modem control lines over the RF. This mode should only be used when RS485 DE is also being used. For all other applications, standard Modem Mode is preferred.

Available Modem control lines when RS485 Modem Mode is enabled:

- Command/Data on Server controls Hop Frame on Client
- GI1 on Server controls GO1 on Client

MAX POWER

Max Power provides a means for controlling the RF output power of the AC4790. Output power and current consumption can vary by as much as $\pm 10\%$ per transceiver for a particular Max Power setting. Contact AeroComm for assistance in adjusting Max Power.

ENGINEER'S TIP

The max power is set during Production and may vary slightly from one transceiver to another. The max power can be set as low as desired but should not be set higher than the original factory setting. A backup of the original power setting is stored in EEPROM address 0x8E.

TIMING DIAGRAMS

AC4490 TIMING DIAGRAMS

Figure 4: Addressed Mode with Timeout

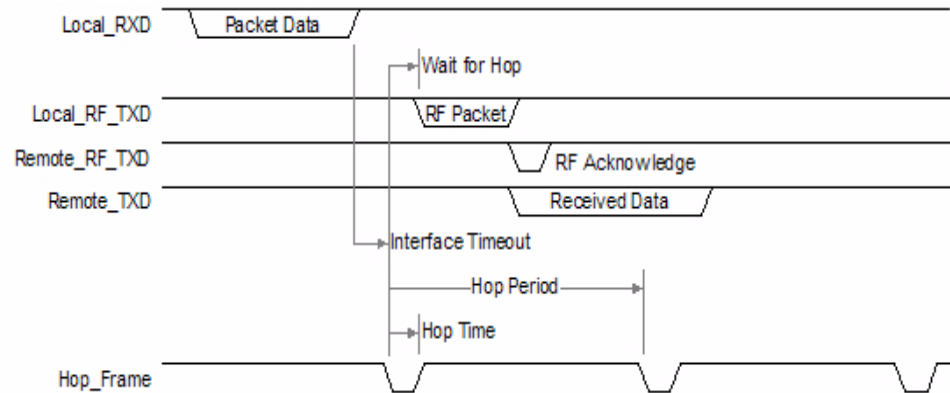

Figure 5: Addressed Mode with Fixed Packet Length

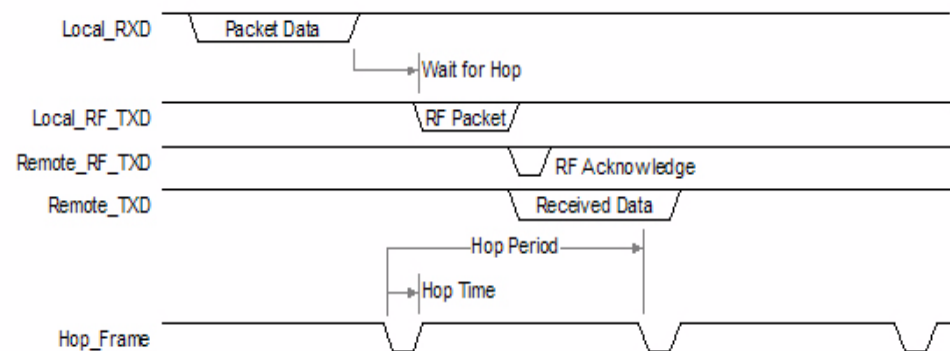
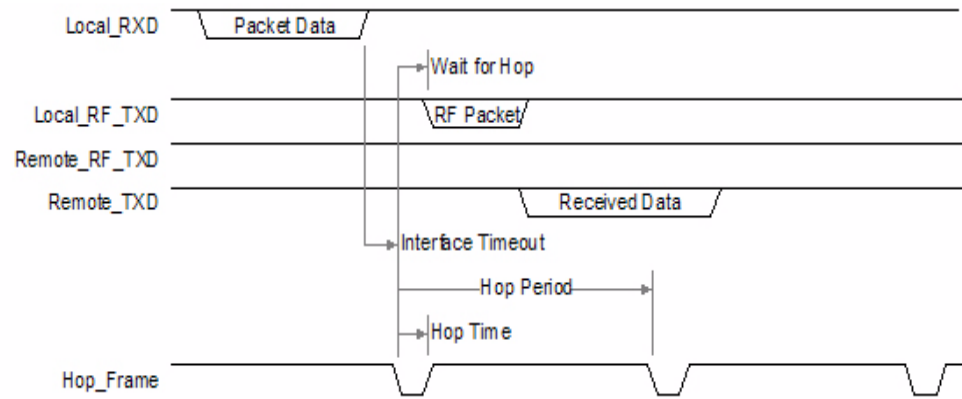
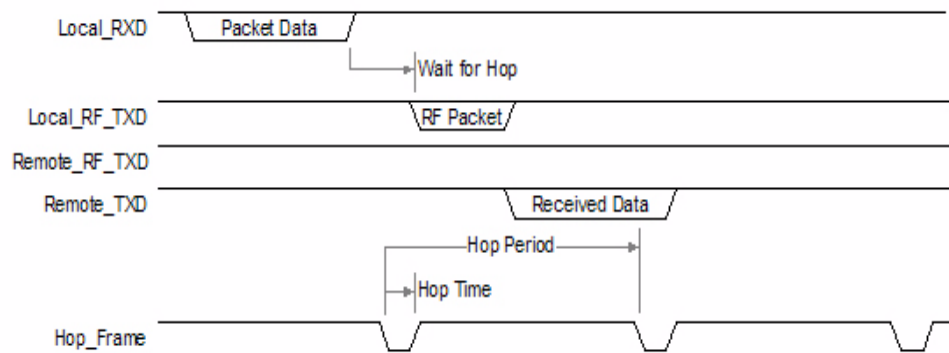

Figure 6: Broadcast Mode with Timeout**Figure 7: Broadcast Mode with Fixed Packet Length**

HARDWARE INTERFACE

Below is a description of all hardware pins used to control the AC4490.

PIN DEFINITIONS

Generic I/O

Both GIn pins serve as generic input pins and both GOn pins server as generic output pins. Reading and writing of these pins can be performed using CC Commands. These pins alternatively serve as control pins when modem mode is enabled.

TXD & RXD

SERIAL TTL

The AC4490-200 accepts 3.3 or 5VDC TTL level asynchronous serial data on the RXD pin and interprets that data as either Command Data or Transmit Data. Data is sent from the transceiver, at 3.3V levels, to the OEM Host via the TXD pin. **Note:** The AC4490-1000 & AC4490-1x1 transceivers ONLY accept 3.3V level signals.

RS-485

When equipped with an onboard RS-485 interface chip, TXD and RXD become the half duplex RS-485 pins. The transceiver interface will be in Receive Mode except when it has data to send to the OEM Host. TXD is the non-inverted representation of the data (RS485A) and RXD is a mirror image of TXD (RS485B). The transceiver will still use RTS (if enabled).

Hop Frame

Transitions logic Low at the start of a hop and transitions logic High at the completion of a hop. The OEM Host is not required to monitor Hop Frame.

CTS

The AC4490 has an interface buffer size of 256 bytes. If the buffer fills up and more bytes are sent to the transceiver before the buffer can be emptied, data loss will occur. The transceiver prevents this loss by asserting CTS High as the buffer fills up and taking CTS Low as the buffer is emptied. CTS On and CTS Off control the operation of CTS. CTS On specifies the amount of bytes that must be in the buffer for CTS to be disabled (logic High). Even while CTS is disabled, the OEM Host can still send data to the transceiver, but it should do so carefully.

Note: The CTS On/Off bytes of the EEPROM can be set to 1, in which case CTS will go high as data is sent in and low when buffer is empty.

GND

Signal Ground. Pins are internally connected.

RTS

With RTS disabled, the transceiver will send any received data to the OEM Host as soon as it is received. However, some OEM Hosts are not able to accept data from the transceiver all of the time. With RTS enabled, the OEM Host can

prevent the transceiver from sending it data by disabling RTS (logic High). Once RTS is enabled (logic Low), the transceiver can send packets to the OEM Host as they are received.

Note: Leaving RTS disabled for too long can cause data loss once the transceiver's 256 byte receive buffer fills up.

Test / 9600 Baud

When pulled logic Low before applying power or resetting, the transceiver's serial interface is forced to a 9600, 8-N-1 (8 data bits, No parity, 1 stop bit). To exit, the transceiver must be reset or power-cycled with Test pin logic High. This pin is used to recover transceivers from unknown baud rates only. It should not be used in normal operation. Instead the transceiver Interface Baud Rate should be programmed to 9600 baud if that rate is desired for normal operation.

ENGINEER'S TIP

Aerocomm does not recommend permanently grounding the Forced_9600 pin. This mode was intended for recovering transceivers from unknown settings and was not intended to be used in real-time communications. The following modes are affected:

Modem mode = disabled
Parity mode = disabled
Interface Timeout = 0x40

It is also possible that future modes not yet implemented will be disabled by grounding Forced_9600.

RSSI

INSTANTANEOUS RSSI

Received Signal Strength Indicator is used by the OEM Host as an indication of instantaneous signal strength at the receiver. The OEM Host must calibrate RSSI without an RF signal being presented to the receiver. Calibration is accomplished by following the steps listed below.

- 1) Power up only one transceiver in the coverage area.
- 2) Measure the RSSI signal to obtain the minimum value with no other signal present.
- 3) Power up another transceiver and begin sending data from that transceiver to the transceiver being measured. Make sure the two transceivers are separated by approximately ten feet.
- 4) Measure the peak RSSI, while the transceiver is in Session, to obtain a maximum value at full signal strength.

VALIDATED RSSI

As RSSI is only valid when the local transceiver is receiving an RF packet from a remote transceiver, instantaneous RSSI can be very tricky to use. Therefore, the transceiver stores the most recent valid RSSI value. The OEM Host issues the Report Last Good RSSI command to request that value. Additionally, validated RSSI can be obtained from Receive Packet and Send Data Complete API commands and from the Probe command. Validated RSSI is not available at the RSSI pin. The following equation approximates the RSSI curve:

$$\text{Signal Strength (dBm)} = (-46.9 \times \text{VRSSI}) - 53.9$$

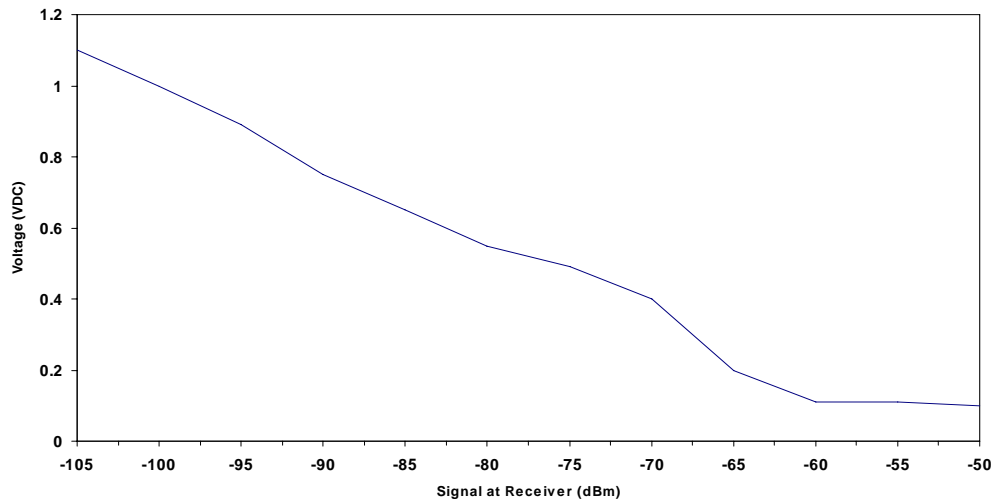

Figure 8: RSSI Voltage vs. Received Signal Strength

UP_Reset

UP_Reset provides a direct connection to the reset pin on the AC4490 microprocessor and is used to force a soft reset.

Command/Data

When logic High, the transceiver interprets incoming OEM Host data as transmit data to be sent to other transceivers and their OEM Hosts. When logic Low, the transceiver interprets OEM Host data as command data.

AD In

AD In can be used as a cost savings to replace Analog-to-Digital converter hardware. Reading of this pin can be performed locally using the Read ADC command found in the On-the-Fly Control Command Reference.

In Range

Reports logic Low when a Client transceiver is in range of a Server radio operating on the same RF Channel and system ID. If a Client cannot hear a Server for the amount of time defined by Range Refresh, it will drive In_Range High and enter search mode looking for a Server. When a server is detected, In_Range will be asserted Low. In_Range will always report Low on Server transceivers.

CONFIGURING THE AC4490

The AC4490 can be configured using the CC Configuration Commands. The CC Commands can be issued using either Hardware or Software Configuration. To use Hardware Configuration, pin 17 of a transceiver must be asserted Low. Software Configuration can be used by entering AT Command Mode before issuing the CC Commands.

Figure 9: AC4490 Configuration Flow

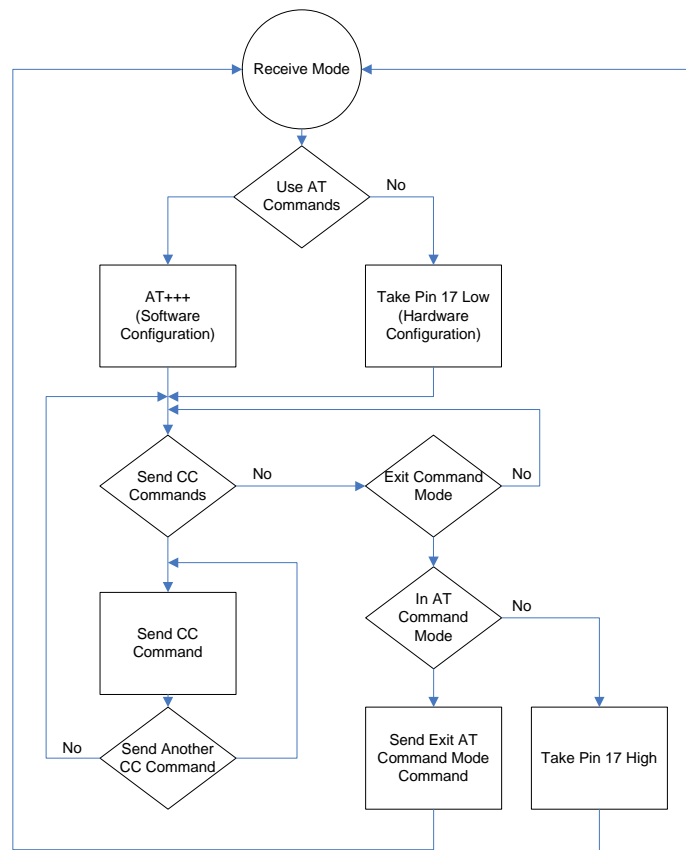

AT COMMANDS

The AT Command mode implemented in the AC4490 creates a virtual version of the Command/Data pin. The “Enter AT Command Mode” Command asserts this virtual pin Low (to signify Command Mode) and the “Exit AT Command Mode” Command asserts this virtual pin High (to signify Data). Once this pin has been asserted Low, all On-the-Fly CC Commands documented in the manual are supported.

On-the-Fly Control Commands

The AC4490 transceiver contains static memory that holds many of the parameters that control the transceiver operation. Using the “CC” command set allows many of these parameters to be changed during system operation. Because the memory these commands affect is static, when the transceiver is reset, these parameters will revert back to the settings stored in the EEPROM. While in CC Command mode using pin 17 (Command/Data), the RF interface of the transceiver is still active. Therefore, it can receive packets from remote transceivers while in CC Command mode and forward these to the OEM Host.

COMMAND/DATA RX DISABLE

The Command/Data RX Disable feature can be enabled in firmware versions 8.6+. When enabled in EEPROM, the radio disables the RF receiver while pin 17 (Command/Data) is Low. To ensure that the radio is not in the middle of transmitting data to the OEM Host, the host should be prepared to receive data for up to 20 ms after taking pin 17 Low.

AT COMMAND MODE

While in CC Command mode using AT Commands, the RF interface of the transceiver is active, but packets sent from other transceivers will not be received. The transceiver uses Interface Timeout/RF Packet Size to determine when a CC Command is complete. Therefore, there should be no delay between each character as it is sent from the OEM Host to the transceiver or the transceiver will not recognize the command. If the OEM Host has sent a CC Command to the transceiver and an RF packet is received by the transceiver, the transceiver will send the CC Command response to the OEM Host before sending the packet. However, if an RF packet is received before the Interface Timeout expires on a CC Command, the transceiver will send the packet to the OEM Host before sending the CC Command response.

When an invalid command is sent, the radio scans the command to see if it has a valid command followed by bytes not associated with the command, in which case the radio discards the invalid bytes and accepts the command. In all other cases, the radio returns the first byte of the invalid command back to the user and discards the rest.

Table 14: Command Quick Reference

Command Name	Command (All Bytes in Hex)						Return (All Bytes in Hex)			
AT Enter CommandMode	0x41	0x54	0x2B	0x2B	0x2B	0x0D	0xCC	0x43	0x4F	0x4D
Exit AT Command-Mode	0xCC	0x41	0x54	0x4F	0x0D	-	0xCC	0x44	0x41	0x54
Status Request	0xCC	0x00	0x00	-	-	-	0xCC	Firmware Version	0x00: Server 0x01: Client in range 0x03: Client out of range	
Change Channel	0xCC	0x02	New Channel		-	-	0xCC	New Channel		-
Change Server/Client	0xCC	0x03	0x00: Server 0x03: Client		-	-	0xCC	Firmware Version	0x00: Server 0x03: Client	
Change Sync Channel	0xCC	0x05	New Sync Channel		-	-	0xCC	New Sync Channel	-	-
Sleep Walk Power Down	0xCC	0x06	-	-	-	-	0xCC	Channel	-	-
Sleep Walk Wake Up	0xCC	0x07	-	-	-	-	0xCC	Channel	-	-
Broadcast Packets	0xCC	0x08	0x00: Broadcast 0x01: Addressed			-	0xCC	0x00 or 0x01	-	-
Write Destination Address	0xCC	0x10	Byte 4 of Dest. MAC		Byte 5	Byte 6	0xCC	Byte 4 of Dest. MAC	Byte 5	Byte 6
Read Destination Address	0xCC	0x11	-	-	-	-	0xCC	Byte 4 of Dest. MAC	Byte 5	Byte 6
Forced Calibration	0xCC	0x12	0x00	0x00	-	-	0xCC	Firmware Version	0x00: Server in Normal Operation 0x01: Client in Normal Operation 0x02: Server in Acquisition Sync 0x03: Client in Acquisition Sync	
Auto Destination	0xCC	0x15	bit-0: Auto Destination bit-1: Auto Channel bit-4: Enable Auto Destination bit-5: Enable Auto Channel				0xCC	bit-0: Auto Destination bit-1: Auto Channel bits-2-7: 0		
Read Digital Inputs	0xCC	0x20	-	-	-	-	0xCC	bit-0: GI0 bit-1: GI1	-	-
Read ADC	0xCC	0x21	0x01: AD In 0x02: Temp 0x03: RSSI		-	-	0xCC	MSB of 10 bit ADC	LSB of 10 bit ADC	
Report Last Valid RSSI	0xCC	0x22	-	-	-	-	0xCC	RSSI	-	-
Write Digital Outputs	0xCC	0x23	bit-0: GO0 bit-1: GO1		-	-	0xCC	bit-0: GO0 bit-1: GO1	-	-
Write DAC	0xCC	0x24	Update Period	Duty Cycle	-	-	0xCC	Update Period	Duty Cycle	-

Table 14: Command Quick Reference

Command Name	Command (All Bytes in Hex)						Return (All Bytes in Hex)				
Set Max Power	0xCC	0x25	New Max Power				-	0xCC	Max Power	-	-
Report Last Packet RSSI	0xCC	0x26	-	-	-	-	0xCC	RSSI	-	-	
Long Range Mode ¹	0xCC	0x27	0x00: Normal Mode (Disabled) 0x01: Long Range Mode (Enabled)				0xCC	0x00: Normal Mode (Disabled) 0x01: Long Range Mode (Enabled)			
Transmit Buffer Empty	0xCC	0x30	-	-	-	-	0xCC	0x00	-	-	
Disable Sync to Channel	0xCC	0x85	-	-	-	-	0xCC	Channel	-	-	
Deep Sleep Mode	0xCC	0x86	-	-	-	-	0xCC	Channel	-	-	
Enter Probe	0xCC	0x8E	0x00: Enter Probe 0x01: Exit Probe				-	0xCC	0x00 or 0x01	-	-
Read Temperature	0xCC	0xA4	-	-	-	-	0xCC	Temp (C)	-	-	
Read Temperature at last calibration	0xCC	0xA5	-	-	-	-	0xCC	Temp (C)			
EEPROM Byte Read	0xCC	0xC0	Start Address		Length		0xCC	Starting Address	Length	Data	
EEPROM Byte Write	0xCC	0xC1	Start Address		Length	Data	Starting Address		Length	Data written	
Soft Reset	0xCC	0xFF	-	-	-	-	-	-	-	-	

1. Available only on AC4490LR-200 and AC4490LR-1000 transceivers.

COMMAND DESCRIPTIONS

Enter AT Command Mode

Prior to sending this command, the OEM Host must ensure that the transceiver's RF transmit buffer is empty. If the buffer is not empty, the radio will interpret the command as data and it will be sent over the RF. This can be accomplished by waiting up to one second between the last packet and the AT command.

Command: 0x41 0x54 0x2B 0x2B 0x2B 0x0D

Number of Bytes Returned: 4

Response: 0xCC 0x43 0x4F 0x4D

Exit AT Command Mode

The OEM Host should send this command to exit AT Command mode and resume normal operation.

Command: 0xCC 0x41 0x54 0x4F 0x0D

Number of Bytes Returned: 4

Response: 0xCC 0x44 0x41 0x54

Status Request

The OEM Host issues this command to request the status of the transceiver.

Command: 0xCC 0x00 0x00

Number of Bytes Returned: 3

Response: 0xCC <Version> <Radio State>

Parameter Range: Radio State = 0x00 for Server, 0x01 for Client in Range, 0x03 for Client out of Range

Change Channel

The OEM Host issues this command to change the channel of the transceiver.

Command: 0xCC 0x02 <Channel>

Number of Bytes Returned: 2

Response: 0xCC <Channel>

Change Server/Client

The OEM Host issues this command to change the mode of the transceiver from Server to Client and vice versa.

Command: 0xCC 0x03 Data1

Number of Bytes Returned: 3

Response: 0xCC <Version> <Mode>

Parameter Range: Mode = 0x00 for Server, 0x03 for Client

Change Sync Channel

The OEM Host issues this command to change the sync channel byte and enable sync to channel.

Command: 0xCC 0x05 <Channel>

Number of Bytes Returned: 3

Response: 0xCC 0x05 <Channel>



Sleep Walk Power-Down

After the Host issues this command, the transceiver will de-assert its In_Range line after entering power down. A Client in power down will remain in sync with a Server for a minimum of 2 minutes. To maintain synchronization with the Server, the Client should re-sync at least once every 2 minutes. This is done by sending the Power Down wake up command and waiting for the In_Range line to go active. Once this occurs, the Client is in sync with the server and can be put back into power-down mode.

Command: 0xCC 0x06

Number of Bytes Returned: 2

Response: 0xCC <Channel>

This command is valid only for Client transceivers.

Sleep Walk Power-Down Wake Up

The OEM Host issues this command to bring the transceiver out of Power Down mode.

Command: 0xCC 0x07

Number of Bytes Returned: 2

Response: 0xCC <Channel>

Broadcast Packets

The OEM Host issues this command to change the transceiver operation between Addressed Packets and Broadcast Packets. If Addressed Packets are selected, the transceiver will send all packets to the transceiver designated by the Destination Address programmed in the transceiver. If Broadcast Packets are selected, the transceiver will send its packets to all transceivers on that network. Setting bit-7 of API Control to 1 can also enable Broadcast Packets.

Command: 0xCC 0x08 <Addressing Mode>

Number of Bytes Returned: 2

Response: 0xCC <Addressing Mode>

Parameter Range: Addressing Mode = 0x00 for Addressed, 0x01 for Broadcast

Write Destination Address

The OEM Host issues this command to the transceiver to change the Destination Address.

Note: Only the three Least Significant Bytes of the MAC Address are used for packet delivery.

Command: 0xCC 0x10 MAC3 MAC2 MAC1

Number of Bytes Returned: 4

Response: 0xCC MAC3 MAC2 MAC1

Parameter Range: 0x00 - 0xFF corresponding to 3 LSB's of destination MAC Address

Read Destination Address

The OEM Host issues this command to the transceiver to read the destination address.

Note: Only the three Least Significant Bytes of the MAC Address are used for packet delivery.

Command: 0xCC 0x11

Number of Bytes Returned: 4

Response: 0xCC MAC3 MAC2 MAC1

Parameter Range: 0x00 - 0xFF corresponding to 3 LSB's of destination MAC Address

Forced Calibration

The OEM Host issues this command to force a recalibration to occur. During the recalibration, the radio will assert CTS high. Recalibration can take up to 3 seconds and the command response will not be sent to the OEM Host until recalibration is complete.

Command: 0xCC 0x12 0x00 0x00

Number of Bytes Returned: 3

Response: 0xCC <Version> <Radio State>

Parameter Range: Radio State = 0x00 for Server in range, 0x01 for Client in range, 0x02 for Server out of range, 0x03 for Client out of range

Auto Destination

The Host issues this command to change the Auto Destination & Auto Channel settings. When issuing this command, the Auto Destination/Auto Channel settings will only be changed if the corresponding enable bit is set (Control1 Parameter, EEPROM address 0x56, bits-4,5)

Command: 0xCC 0x15 <Data1 >

Number of Bytes Returned: 2

Response: 0xCC <Data2>

Parameter Range: Data1 = bit-0: Auto Destination, bit-1: Auto Channel, bit-4: Enable Auto Destination modification, bit-5: Enable Auto Channel Modification; Data2 = bit-0: New Auto Destination setting, bit-1: New Auto Channel Setting, bits 2 - 7:0

Read Digital Inputs

The OEM Host issues this command to read the state of both digital input lines.

Command: 0xCC 0x20

Number of Bytes Returned: 2

Response: 0xCC <Data1 >

Parameter Range: Data1 = bit-0: GI0, bit-1: GI1

Read ADC

The OEM Host issues this command to read any of the three onboard 10-bit A/D converters. Because the RF is still active in On-the-Fly Command Mode, the transceiver will not process the command until there is no activity on the network. The Read RSSI command is therefore useful for detecting interfering sources but will not report the RSSI from a remote transceiver on the network. The equations for converting these 10 bits into analog values are as follows:

Analog Voltage = (10 bits / 0x3FF) * 3.3V

Temperature (°C) = ((Analog Voltage - 0.3) / 0.01) - 30

RSSI value (dBm) = -105 + (0.22 * (0x3FF - 10 bits))

Command: 0xCC 0x21 <Data1 >

Number of Bytes Returned: 3

Response: 0xCC <Data2> <Data3>

Parameter Range: Data1 = 0x00: AD In, 0x01: Temperature, 0x02: RSSI; Data2 = MSB of requested 10-bit ADC value; Data3 = LSB of requested 10-bit ADC value

Report Last Valid RSSI

Since RSSI values are only valid when the local transceiver is receiving an RF packet from a remote transceiver, instantaneous RSSI can be tricky to use. Therefore, the transceiver stores the most recent valid RSSI value as measured the last time the transceiver received a packet or beacon. The Host issues this command to retrieve that value.

Command: 0xCC 0x22

Number of Bytes Returned: 2

Response: 0xCC <Last Valid RSSI>

Note: This value will default to 0xFF on a Client and 0x00 on a Server if no valid RSSI measurement has been made since power-up.

Table 15: Received Signal Strength

Signal Strength (dBm)	RSSI Value (Hex)	Signal Strength (dBm)	RSSI Value (Hex)
4	0x0E	-62	0x2B
-2 to 1	0x0D	-66	0x40
-12 to -6	0x0C	-69	0x55
-36 to -22	0x0B	-72	0x62

Table 15: Received Signal Strength

Signal Strength (dBm)	RSSI Value (Hex)	Signal Strength (dBm)	RSSI Value (Hex)
-42 to -39	0x0C	-76	0x71
-46	0x0D	-79	0x78
-49	0x0E	-82	0x84
-52	0x11	-86	0x9A
-56	0x17	-89	0xAD
-59	0x1C	-92	0xBD

Write Digital Outputs

The OEM Host issues this command to write both digital output lines to particular states.

Note: This command should only be used when Protocol Status (0xC2) is not set to 0xE3.

Command: 0xCC 0x23 <Data1>

Number of Bytes Returned: 2

Response: 0xCC <Data1>

Parameter Range: Data1 = bit-0: GO0, bit-1: GO1

Write DAC

The OEM Host issues this command to write DA_Out to a particular voltage. The transceiver uses a PWM (Pulse Width Modulator) to generate the analog voltage. The theory behind a PWM is that a binary pulse is generated with a fixed duty cycle and rate. As such, this pin toggles between High & Low. This signal is filtered via an on-board R-C circuit and an analog voltage is generated. Duty cycle specifies the ratio of time in one cycle that the pulse spends High proportionate to the amount of time it spends Low. So, with a duty cycle of 50% (0x80), the pulse is High 50% of the time and Low 50% of the time; therefore the analog voltage would be half of 3.3V or 1.15V. A broad filter has been implemented on the transceiver and there is no advantage to using a slower update period. Generally, a faster update period is preferred.

Command: 0xCC 0x24 <Data1> <Data2>

Number of Bytes Returned: 3

Response: 0xCC <Data1> <Data2>

Parameter Range: Data1 = Update Period; Data2 = Duty cycle

$$T_{\text{update}} = \frac{(255 \times (\text{Data1} + 1))}{14.7456^6}$$

$$V_{\text{out}} = \frac{\text{Data2}}{0xFF} \times 3.3V$$

Set Max Power

The OEM Host issues this command to limit the maximum transmit power emitted by the transceiver. This can be useful to minimize current consumption and satisfy certain regulatory requirements. The radios are shipped at maximum allowable power.

Command: 0xCC 0x25 <Max Power>

Number of Bytes Returned: 2

Response: 0xCC <Max Power>

Long Range Mode

The OEM Host issues this command to temporarily enable or disable Long Range Mode in the transceiver.

Note: Only available on AC4490LR-200 / AC4490LR-1000 transceivers with firmware v6.7+.

Command: 0xCC 0x27

Number of Bytes Returned: 2

Response: 0xCC <Data1>

Parameter Range: Data1 = 0x00: Disabled, 0x01: Enabled

Transmit Buffer Empty

The OEM Host issues this command to determine when the RF transmit buffer is empty. The Host will not receive the transceiver response until that time.

Command: 0xCC 0x30

Number of Bytes Returned: 2

Response: 0xCC 0x00

Disable Sync-to-Channel

The OEM Host issues this command to disable Sync to Channel mode.

Command: 0xCC 0x85

This command is valid only for Servers.

Number of Bytes Returned: 2

Response: 0xCC <Channel>

Deep Sleep Mode

The OEM Host issues this command to put the transceiver into Deep Sleep mode. Once in Deep Sleep mode, the transceiver disables all RF communications and will not respond to any further commands until being reset or power-cycled.

Command: 0xCC 0x86

Number of Bytes Returned: 2

Response: 0xCC <Channel>

This command is valid for both Servers and Clients.

Read Temperature

The OEM Host issues this command to read the onboard temperature sensor. The transceiver reports the temperature in °C where 0x00 - 0x80 corresponds to 0 - 80 °C and where 0xD8 - 0x00 corresponds to -40 - 0 °C.

Command: 0xCC 0xA4

Number of Bytes Returned: 2

Response: 0xCC <Temperature>

Parameter Range: Temperature = 0xD8 - 0x80

Read Temperature at Last Calibration

The OEM Host issues this command to read the temperature of the radio at the time of its last calibration. The transceiver reports the temperature in °C where 0x00 - 0x80 corresponds to 0 - 80 °C and where 0xD8 - 0x00 corresponds to -40 - 0 °C.

Command: 0xCC 0xA5

Number of Bytes Returned: 2

Response: 0xCC <Temperature>

Parameter Range: Temperature = 0xD8 - 0x80

Probe

When the OEM Host issues this command, the transceiver sends out a query every 500 ms. The transceivers, upon receiving the query, randomly choose a query to respond to. After responding to a Probe, the transceiver will wait at least 10 seconds before responding to another probe.

Command: 0xCC 0x8E <Data1 >

Number of Bytes Returned: 2

Response: 0xCC <Data1 >

Parameter Range: 0x00 = Disable Probe, 0x01 = Enable Probe

Note: This command can only be sent from a server radio.

Transceiver's Response

Upon hearing the remote transceiver's probe acknowledge, the transceiver sends a response to the OEM Host.

Command: N/A

Number of Bytes Returned: 5

Response: 0xCC Data1 MAC3 MAC2 MAC1

Parameter Range: Data 1 = bit-7: 0 for Client, bit-7: 1 for Server; bits 6-0: RF Channel



EEPROM Byte Read

Upon receiving this command, a transceiver will respond with the desired data from the addresses requested by the OEM Host.

Command: 0xCC 0xC0 <Address> <Length>

Number of Bytes Returned: 4+

Response: 0xCC <Address> <Length> <Requested Data>

EEPROM Byte Write

Upon receiving this command, a transceiver will write the data byte to the specified address but will not echo it back to the OEM Host until the EEPROM write cycle is complete (up to 10 ms).

Command: 0xCC 0xC1 <Address> <Length> <Data>

Number of Bytes Returned: 4+

Response: 0xCC <Address> <Length> <Data written>

Multiple byte writes of up to 128 bytes are allowed. An EEPROM boundary exists between addresses 0x7F and 0x80. No single EEPROM write command shall write to addresses on both sides of that EEPROM boundary.

Note: Only the last byte written will be displayed in the command response.

Reset

The OEM Host issues this command to perform a soft reset of the transceiver. Any transceiver settings modified by CC commands will revert to the values stored in the EEPROM.

Command: 0xCC 0xFF

Number of Bytes Returned: None

Response: None

EEPROM PARAMETERS

The OEM Host can program various parameters that are stored in EEPROM which become active after a power-on reset. The table below gives the locations and descriptions of the parameters that can be read/written by the OEM Host. Factory default values are also shown. Do not write to any EEPROM addresses other than those listed below. Do not copy one transceiver's EEPROM to another transceiver as doing so may cause the transceiver to malfunction.

Table 16: EEPROM Parameters

Parameter	EEPROM Address	Length (Bytes)	Range	Default	Description
Product ID	0x00	40			40 bytes - Product identifier string. Includes revision information for software and hardware.
Range Refresh	0x3D	1	0x01 - 0xFF	0x18	Specifies the maximum amount of time a transceiver will report In Range without having heard a Server's beacon (equal to hop period * value). Do not set to 0x00.
Stop Bit Delay	0x3F	1	0x00 - 0xFF	0xFF	For systems employing the RS-485 interface or Parity, the serial stop bit might come too early. Stop bit delay controls the width of the last bit before the stop bit occurs. 0xFF = Disable Stop Bit Delay (12 us) 0x00 = (256 * 1.6 us) + 12 us 0x01 - 0xFE = (value * 1.6 us) + 12 us
Channel Number	0x40	1	0x00 - 0x37	1x1: 0x00 200: 0x00 1000: 0x10	Set 0 = 0x00 - 0x0F (US/Canada): 1x1/200 Set 1 = 0x10 - 0x2F (US/Canada): 1x1/1000 Set 2 = 0x30 - 0x37 (US/Canada): 1x1/200; Australia: 1x1/200/1000
Server/Client Mode	0x41	1	0x01 - 0x02	0x02	0x01 = Server 0x02 = Client
Baud Rate Low	0x42	1	0x00 - 0xFF	0xFC	Low byte of the interface baud rate. Default baud rate is 57,600.
Baud Rate High	0x43	1	0x00	0x00	High byte of interface baud. Always 0x00

Table 16: EEPROM Parameters

Parameter	EEPROM Address	Length (Bytes)	Range	Default	Description
Control 0	0x45	1	0x00 - 0xFF	0x14	Settings are: bit-7: One Beacon Mode 0 = Beacon every hop (disabled) 1 = Beacon once per hop cycle (enabled) bit-6: DES Enable 0 = Disable Encryption 1 = Enable Encryption bit-5: Sync to Channel 0 = Disabled 1 = Enabled bit-4: Aerocomm Use Only bit-3: Aerocomm Use Only bit-2: Aerocomm Use Only bit-1: RF Delivery 0 = Addressed packets 1 = Broadcast packets bit-0: Aerocomm Use Only
Frequency Offset	0x46	1	0x00 - 0xFF	0x01	Protocol parameter used in conjunction with Channel Number to satisfy unique regulations.
CMD/Data RX Disable	0x4B	1	0xE3, 0xFF	0xFF	0xE3 = Enable CMD/Data RX Disable 0xFF = Disable CMD/Data RX Disable
Transmit Retries	0x4C	1	0x01 - 0xFF	0x10	Maximum number of times a packet is sent out when Addressed packets are selected.
Broadcast Attempts	0x4D	1	0x01 - 0xFF	0x04	Maximum number of times a packet is sent out when Broadcast packets are selected.
API Control	0x56	1	0x00 - 0xFF	0x43	Settings are: bit-7: Aerocomm Use Only bit-6: Aerocomm Use Only bit-5: Unicast Only 0 = Disabled 1 = Enabled bit-4: Auto Destination 0 = Use destination address 1 = Use auto destination bit-3: Client Auto Channel 0 = Disabled 1 = Enabled bit-2: RTS Enable 0 = Ignore RTS 1 = Transceiver obeys RTS bit-1: Duplex 0 = Half Duplex 1 = Full Duplex bit-0: Auto Config 0 = Use EEPROM values 1 = Auto Configure values
Interface Timeout	0x58	1	0x02 - 0xFF	0x04	Specifies a byte gap timeout, used in conjunction with RF Packet Size to determine when a packet coming over the interface is complete (0.5 ms per increment).
Sync Channel	0x5A	1	0x00 - 0xFF	0x01	Used to synchronize the hopping of collocated systems to minimize interference.

Table 16: EEPROM Parameters

Parameter	EEPROM Address	Length (Bytes)	Range	Default	Description
RF Packet Size	0x5B	1	0x01 - 0x80	0x80	Used in conjunction with Interface Timeout; specifies the maximum size of an RF packet.
CTS On	0x5C	1	0x01 - 0xFF	0xD2	CTS will be deasserted (High) when the transmit buffer contains at least this many characters.
CTS Off	0x5D	1	0x00 - 0xFE	0xAC	Once CTS has been deasserted, CTS will be reasserted (Low) when the transmit buffer is contains this many or less characters.
Max Power	0x63	1	0x00 - 0x60	Set in Production & can vary	Used to increase/decrease the output power. The transceivers are shipped at maximum allowable power.
Modem Mode	0x6E	1	0xE3, 0xFF	0xFF	0xE3 = Enable Modem Mode 0xFF = Disable Modem Mode
Parity	0x6F	1	0xE3, 0xFF	0xFF	0xE3 = Enable Parity 0xFF = Disable Parity Note: Enabling parity cuts throughput and the interface buffer size in half.
Destination ID	0x70	6	0x00 - 0xFF	0xFF	Specifies destination for RF packets
System ID	0x76	1	0x00 - 0xFF	0x01	Similar to network password. Radios must have the same system ID to communicate with each other.
Long Range Mode	0x7D	1	0xE3, 0xFF	0xE3	Used to enable/disable Long Range mode. 0xE3 = Enable Long Range Mode 0xFF = Disable Long Range Mode Note: Only valid on AC4490LR-200 and AC4490LR-1000 transceivers with firmware v6.7+.
RS-485 DE	0x7F	1	0xE3, 0xFF	0xFF	0xE3 = GO0 is active Low DE for control of external RS-485 hardware 0xFF = Disable RS-485 DE
MAC ID	0x80	6	0x00 - 0xFF		Factory programmed unique IEEE MAC address.
Original Max Power	0x8E	1		Set in Production and can vary	Copy of original max power EEPROM setting. This address may be referenced but should not be modified.
RS485 Modem Mode	0x8F	1	0xE3, 0xFF	0xFF	0xE3 = Enable RS485 Modem Mode 0xFF = Disable RS485 Modem Mode
Product ID	0x90	15			0x90 - 0x93: Product ID 0x94 - 0x95: Prefix (CL, CN, or AC) 0x96 - 0x99: Power (200M, 200A, 1000, 1x1) Note: There will be a period in front of the 1x1 to keep the field at four bytes 0x9A - 0x9C: Interface (232, 485, TTL) 0x9D - 0x9E: Setup script (01 is stock) 0x9F: Reserved for future use; always 0xFF

Table 16: EEPROM Parameters

Parameter	EEPROM Address	Length (Bytes)	Range	Default	Description
Protocol Status / Receive ACK	0xC0	1	0xE3, 0xFF	0xFF	0xE3 = GO0 outputs the Protocol Status and GO1 outputs the Received Acknowledgement signal 0xFF = Disable Protocol Status / Receive ACK
Receive API	0xC1	1	0xE3, 0xFF	0xFF	0xE3 = Enabled 0xFF = Disabled
Enhanced API Control	0xC6	1		0xF8	Settings are: bit-7: Enhanced API Control Enable 0 = Enable Enhanced API Control 1 = Disable Enhanced API Control bit-6: Aerocomm Use Only bit-5: Aerocomm Use Only bit-4: Aerocomm Use Only bit-3: Aerocomm Use Only bit-2: Send Data Complete Enable 0 = Disable 1 = Enable bit-1: API Transmit Packet Enable 0 = Disable 1 = Enable bit-0: Enhanced API Receive Packet Enable 0 = Disable 1 = Enable
Auto Calibrate	0xCC	1	0xE3, 0xFF	0xFF	0xE3 = Enable Auto Calibrate 0xFF = Disable Auto Calibrate
DES Key	0xD0	7	0x00 - 0xFF		56-bit Data Encryption key

DIMENSIONS

MECHANICAL DRAWINGS

Interface Connector - 20 pin OEM Interface connector (Molex 87759-0030, mates with Samtec SMM-110-02-S-D

MMCX Jack - Antenna Connector (Johnson Components 135-3711-822)

Figure 10: AC4490 (with MMCX connector) Mechanical

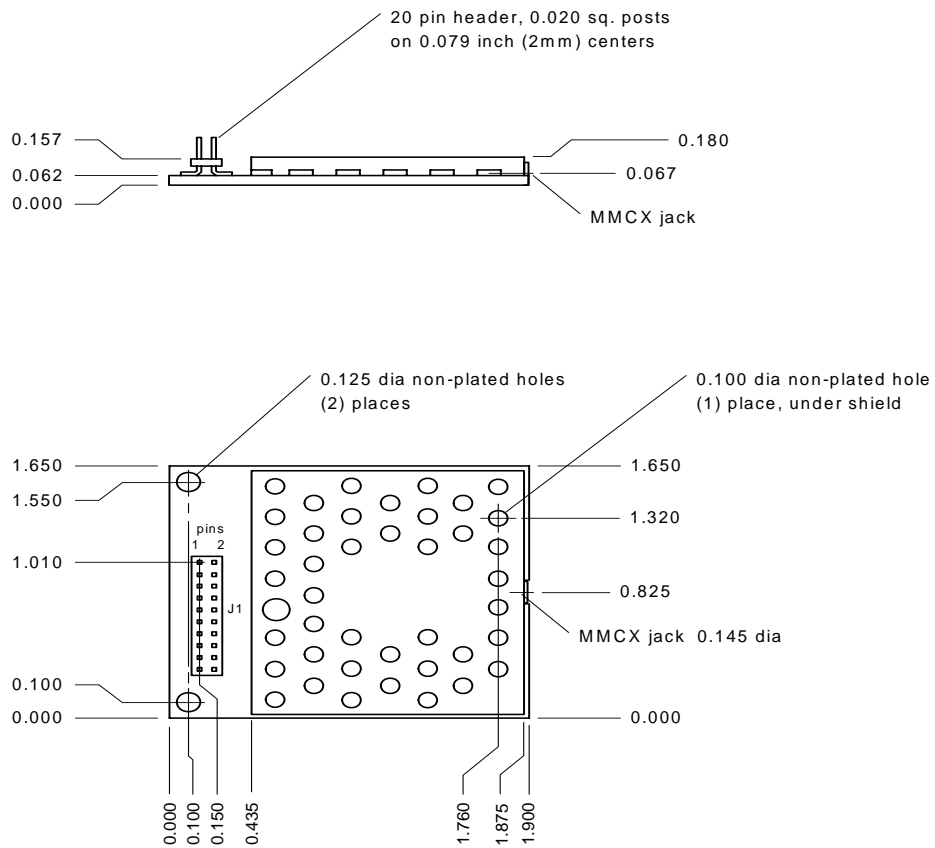

Figure 11: AC4490 with integral gigaAnt Antenna (on bottom) Mechanical

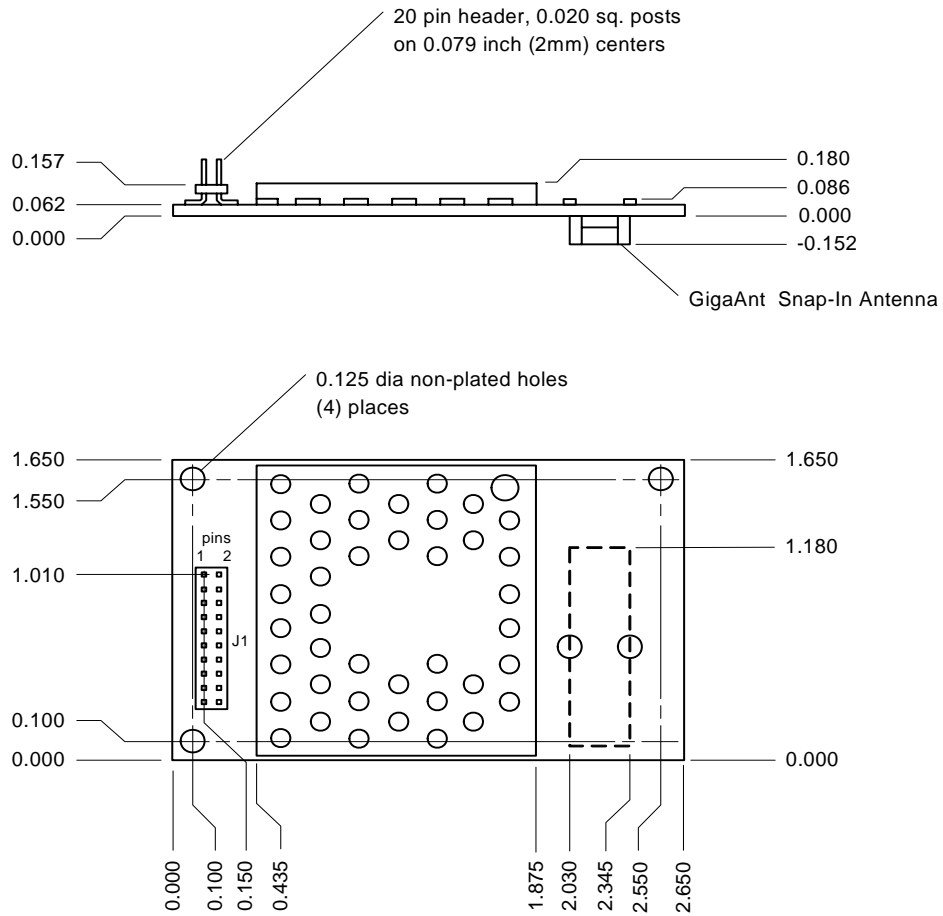

Figure 12: AC4490-1x1 Mechanical

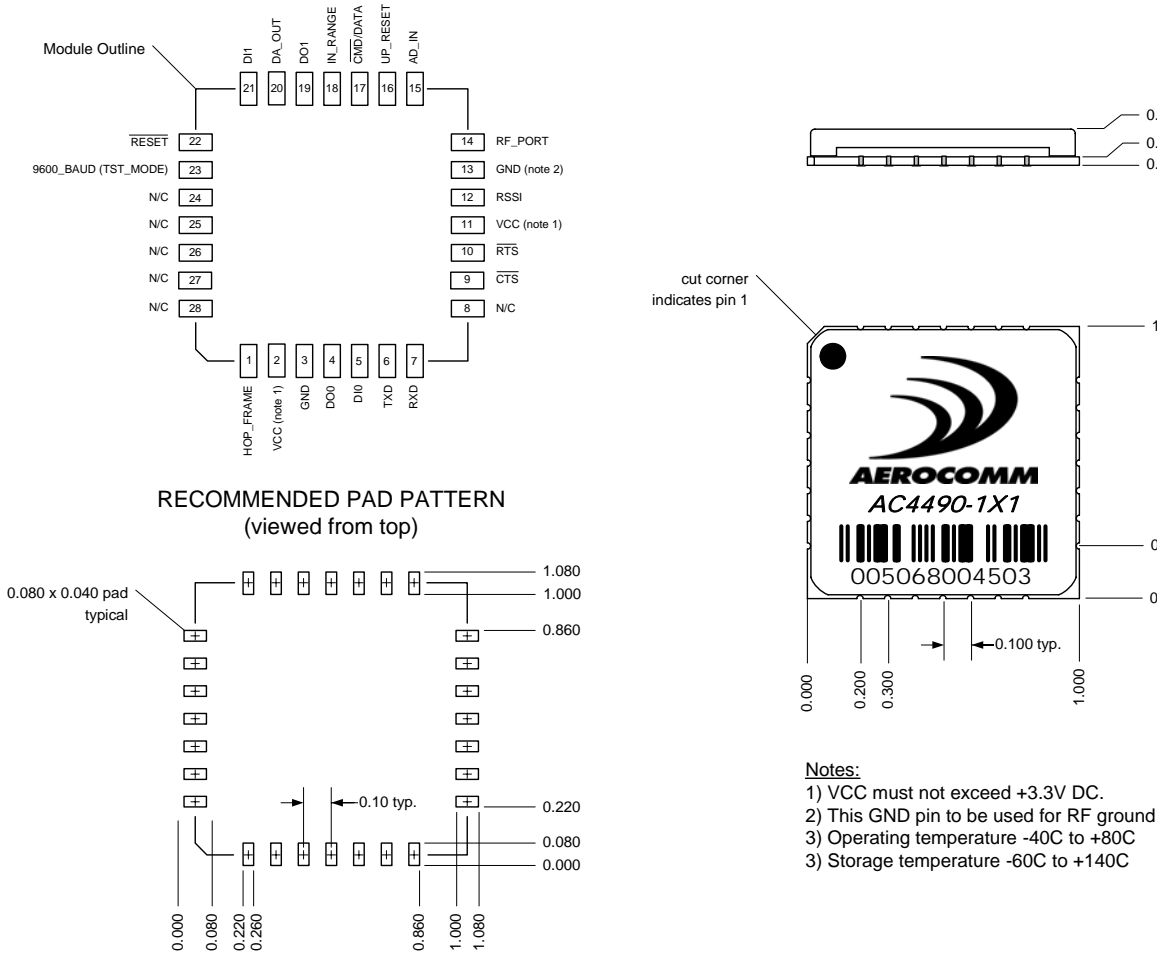
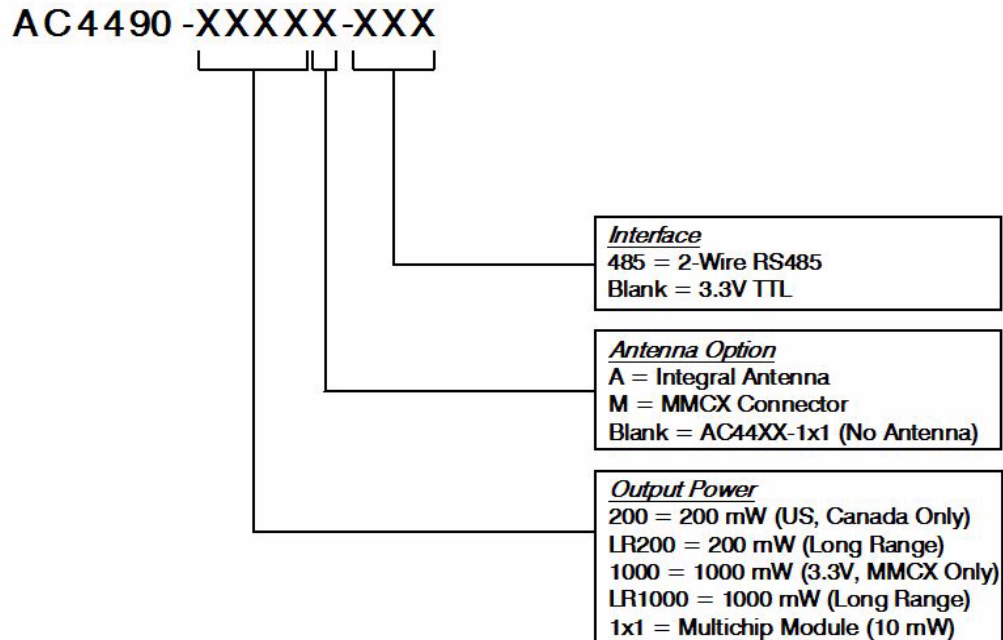

Figure 13: AC4490-1x1 PCB Considerations

ORDERING INFORMATION

PRODUCT PART NUMBER TREE



DEVELOPER KIT PART NUMBERS

All of the above part numbers can be ordered as a development kit by prefacing the part number with “SDK-”. As an example, part number AC4490-200A can be ordered as a development kit using the part number: SDK-AC4490-200A.

All developer’s kits include (2) transceivers, (2) development boards, (2) 7.5 VDC unregulated power supplies, (2) serial cables, (2) USB cables, (2) antennas, configuration/testing software and integration engineering support.

COMPLIANCY INFORMATION

AC4490-1X1

Due to the RF antenna trace residing on the OEM Host PCB, the FCC will not grant modular approval for the AC4490-1x1 and requires the OEM to submit their completed design for approval. Contact AeroComm for the approval procedure.

AGENCY IDENTIFICATION NUMBERS

Agency compliancy is a very important requirement for any product development. AeroComm has obtained modular approval for its products so the OEM only has to meet a few requirements to be eligible to use that approval. The corresponding agency identification numbers and approved antennas are listed below.

Table 17: Agency Identification Numbers

Part Number	US/FCC	Canada/IC
AC4490-200A	KQLAC4490-100	2268C-AC4490
AC4490-200/AC4490LR-200	KQL-4x90200	2268C-4x90200
AC4490-1000	KQL-AC4490	2268C-AC44901000

APPROVED ANTENNA LIST

The following antennas are approved for use with the AC4490 as identified. The OEM is free to choose another vendor's antenna of like type and equal or lesser gain as a listed antenna and still maintain compliance.

Table 18: AC4490 Approved Antennas

AeroComm Part Number	Manufacturer Part Number	Manufacturer	Type	Gain (dBi)	200A	200M	200LR	1000M
0600-00019	S467FL-5-RMM-915S	Nearson	1/2 Wave Dipole	2	-	X	X	X
0600-00025	S467FL-5-RMM-915	Nearson	1/2 Wave Dipole	2	-	X	X	X
0600-00024	S467AH-915	Nearson	1/2 Wave Dipole	2	-	X	X	X
0600-00027	S467AH-915R	Nearson	1/2 Wave Dipole	2	-	X	X	X
0600-00028	S161AH-915R	Nearson	1/2 Wave Dipole	2.5	-	X	X	X
0600-00029	S161AH-915	Nearson	1/2 Wave Dipole	2.5	-	X	X	X
0600-00030	S331AH-915	Nearson	1/4 Wave Dipole	1	-	X	X	X

Table 18: AC4490 Approved Antennas

AeroComm Part Number	Manufacturer Part Number	Manufacturer	Type	Gain (dBi)	200A	200M	200LR	1000M
-	1020B5812-04 Flavus	gigaAnt	Microstrip	-0.5	X	-	-	-
-	Y2283 ¹	Comtelco	Yagi	6 dBd	-	X	X	X
-	Y2283A-915-10RP	Comtelco	Yagi	6 dBd	-	X	X	X
-	SG101N915 ²	Nearson	Omni	5	-	X	X	X
-	SG101NT-915	Nearson	Omni	5	-	X	X	X
-	GM113	V.Torch	Omni	3.5	-	X	X	-
-	PC8910NRTN	Cushcraft	Yagi	11 dBd	-	-	X	-
-	ANT-DB1-RMS	Antenna Factor	Monopole	3	-	X	X	-

1. Strictly requires professional installation, minimum cable length 3 m, cable RG 213 or equivalent (minimum 2.5 dB attenuation required)
2. Strictly requires professional installation.

FCC / IC REQUIREMENTS FOR MODULAR APPROVAL

In general, there are two agency classifications of wireless applications; portable and mobile.

Portable - Portable is a classification of equipment where the user, in general, will be within 20 cm of the transmitting antenna. Portable equipment is further broken down into two classes; within 2.5 cm of human contact and beyond 2.5 cm (**Note:** Ankles, feet, wrists, and hands are permitted to be within 2.5 cm of the antenna even if the equipment is designated as being greater than 2.5 cm). The AC4790 is not agency approved for portable applications. The OEM is required to have additional testing performed to receive this classification. Contact AeroComm for more details.

Mobile - Mobile defines equipment where the user will be 20 cm or greater from the transmitting equipment. The antenna must be mounted in such a way that it cannot be moved closer to the user with respect to the equipment, although the equipment may be moved. (**Note:** Ankles, feet, wrists, and hands are permitted to be within 20 cm of mobile equipment).

OEM EQUIPMENT LABELING REQUIREMENTS

WARNING: The OEM must ensure that FCC labeling requirements are met. This includes a clearly visible label on the outside of the OEM enclosure specifying the appropriate AeroComm FCC identifier for this product as well as the FCC notice below. The FCC identifiers are listed above.

Contains FCC ID: KQLAC4490-100 / KQLAC4490 / KQL-4x90200

The enclosed device complies with Part 15 of the FCC Rules. Operation is subject to the following two conditions: (1) This device may not cause harmful interference, and (2) This device must accept any interference received, including interference that may cause undesired operation.



Label and text information should be in a size of type large enough to be readily legible, consistent with the dimensions of the equipment and the label. However, the type size for the text is not required to be larger than eight point.

ANTENNA REQUIREMENTS

WARNING: This device has been tested with an MMCX connector with the above listed antennas. When integrated into the OEM's product, these fixed antennas require professional installation preventing end-users from replacing them with non-approved antennas. Antenna Y2283 & SG101N915 strictly require professional installation. Any antenna not in the previous table must be tested to comply with FCC Section 15.203 for unique antenna connectors and Section 15.247 for emissions. Contact AeroComm for assistance.

Caution: Any change or modification not expressly approved by AeroComm could void the user's authority to operate the equipment.

WARNINGS REQUIRED IN OEM MANUALS

WARNING: This equipment has been approved for mobile applications where the equipment should be used at distances greater than 20 cm from the human body (with the exception of hands, feet, wrists, and ankles). Operation at distances of less than 20 cm is strictly prohibited and requires additional SAR testing.

CHANNEL WARNING

The OEM must prevent the end-user from selecting a channel not approved for use by the FCC.

APPENDIX I - SAMPLE POWER SUPPLY

Below is a simple switching power supply that provides enough current to easily power any Aerocomm OEM module. It utilizes low cost, off the shelf components that fit into a small area. This supply has an input voltage range of +6 volts to +18 volts and will output +3.4 volts at 1.5 amps.

Included is a schematic, bill of materials with manufacture's name and part numbers and a sample PCB layout. It is important to follow the layout suggestions and use large areas of copper to connect the devices as shown in the layout. It is also important to hook up the ground traces as shown and use multiple vias to connect input and output capacitors to the bottom side ground plane.

If the input voltage will be less than 12 volts then C1 and C2 can be replaced with a single 100uF 20 volt capacitor (same part number as C7). This will reduce board space and lower costs further. If you are powering an AC5124 module, R1 can be changed to a 373 ohm 1% resistor. This will change the output to +5 volts at 1.0 amps.

BILL OF MATERIALS

Table 19: Power Supply Bill of Materials

Qty	Reference	Value	Description	Mfg.	Mfg. part number
1	R1	210	Res, 0603, 210, 1/16W, 1%	KOA	RK73H1JT2100F
1	R2	127	Res, 0603, 127, 1/16W, 1%	KOA	RK73H1JT1270F
2	C1 C2	47uF	Cap, Tant, 7343, 47uF, 35V	AVX	TPSE476M035R0200
3	C3 C4 C5	0.1uF	Cap, Cer, 0603, 0.1uF, Y5V, 25V	Murata	GRM39Y5V104Z025AD
1	C6	3300pF	Cap, Cer, 0603, 3300pF, X7R, 50V	Murata	GRM39X7R332K050AD
1	C7	100uF	Cap, Tant, 7343, 100uF, 20V	Kemet	T491X107K020A5
1	D1	B230/A	Diode, SMB, B230/A, 2A, Schott-key	Diodes, Inc.	B230/A
1	D2	LL4148	Diode, MELF, LL4148, Switch Diode	Diodes, Inc.	LL4148
1	L1	15uH	Xfmr, 2P, SMT, 15uH, 2A	Coiltronics	UP2.8B150
1	U1	CS51413	IC, CS51413, 8P, SO, Switch Reg Ctrl.	On-Semi-cond.	CS51413

SCHEMATIC

Switching Power Supply

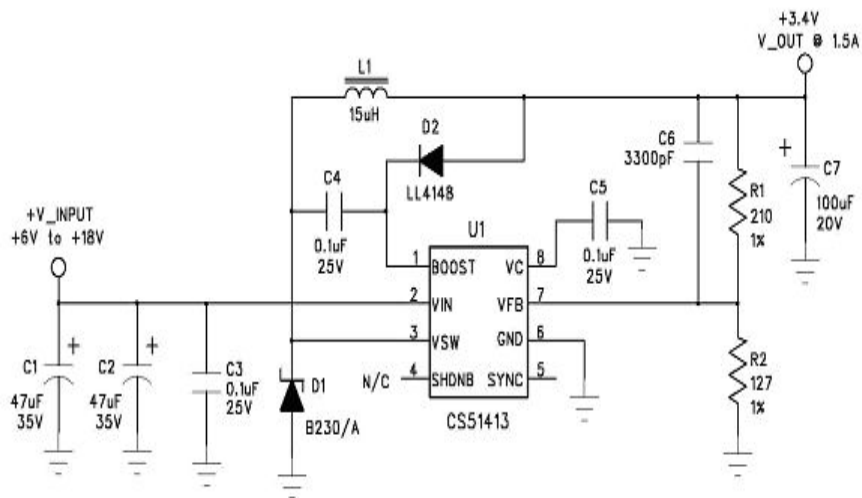

PCB LAYOUT

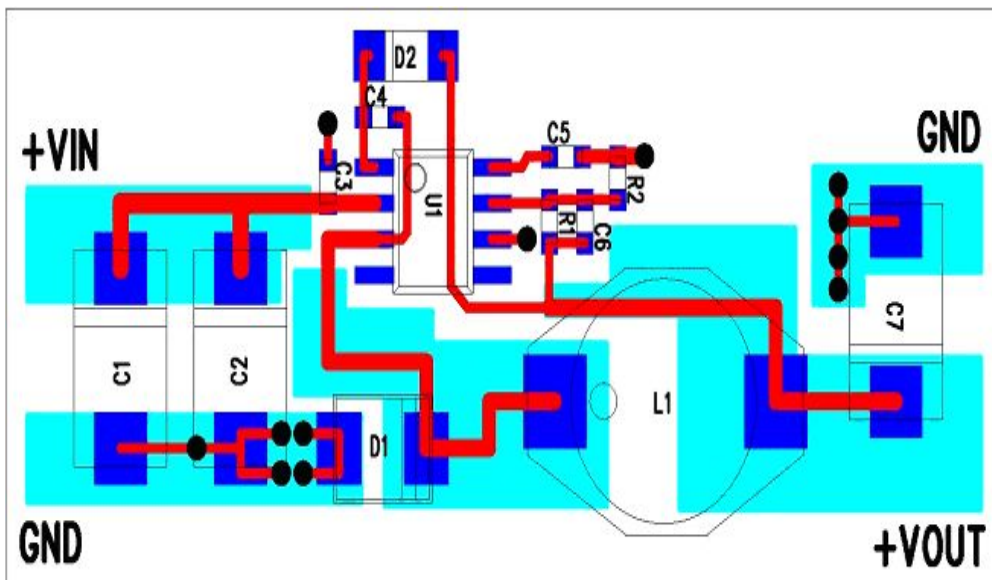

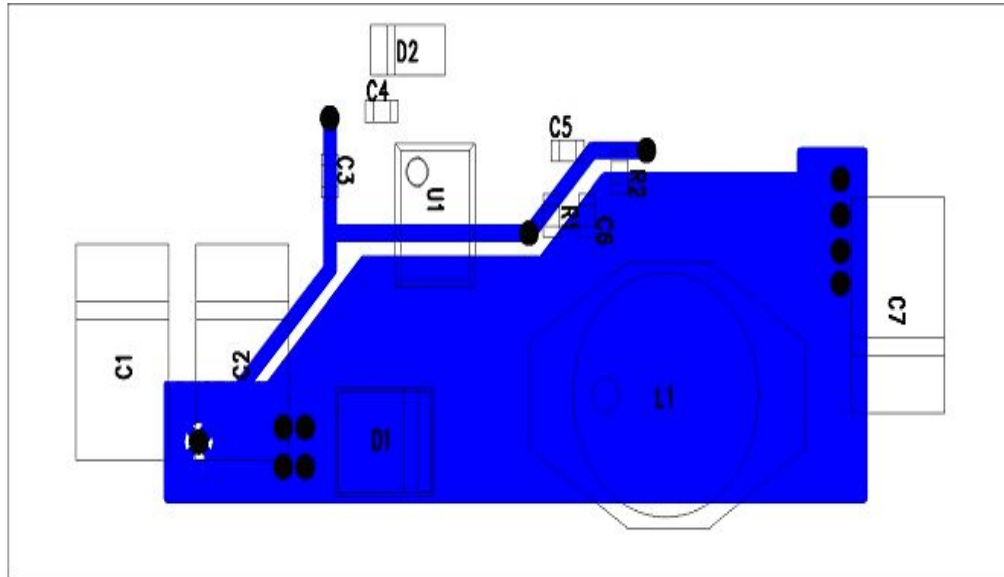

APPENDIX II - 5V TO 3.3V LEVELS

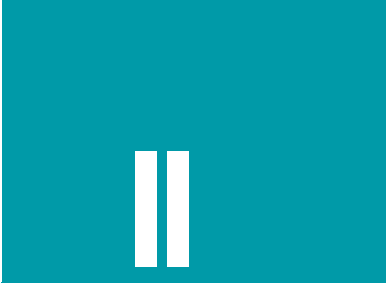

All inputs on the AC4490-200 & AC4490-1000 are weakly pulled high via 10 kohm resistors. The AC4490-200 has 5V inputs while the AC4490-1000 & AC4490-1x1 have 3.3V inputs. The AC4490-200 uses an octal buffer to drop the 5V to the required 3.3V level; the -1000 and -1x1 leave this to the OEM.

Some of the most common voltage conversion methods are described below.

VOLTAGE LEVEL CONVERSION IC'S

This is the easiest and most efficient method. Aerocomm recommends the TI SN74LVC244A Octal Buffer/Driver. Inputs can be driven from either 3.3 or 5V systems, allowing the device to be used in a mixed 3.3/5V system.

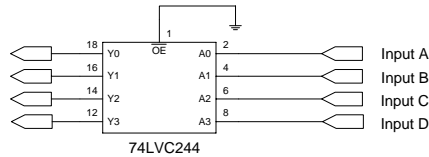
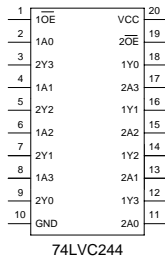

PASSIVE RESISTOR VOLTAGE DIVIDER

While a resistor voltage divider can successfully drop the 5V to the required 3.3V, it will draw static current all of the time. Typically this method is only suitable for one-way 5V to 3.3V conversion. When choosing the resistor values, one needs to include the radio's internal 10 kohm resistors on the input signals.

APPENDIX III - API



The API feature set of the AC4490 provides powerful packet routing capabilities to the OEM Host. The number of API configurations is endless as individual radios can all be configured differently to suit the OEM Host's varying needs. Some of the most common implementations are described in the following pages.

POLLING NETWORK

Many applications require multiple locations to report back to a single access point. One solution would be to enter Command mode, change the transceiver's destination address and then exit Command mode to resume normal operation. When it is time to communicate with another transceiver, the process would be repeated; costing time and inevitably reduction in throughput as unnecessary commands are issued. As an alternative, the Transmit API command can be used to control packet routing on a packet-by-packet basis.

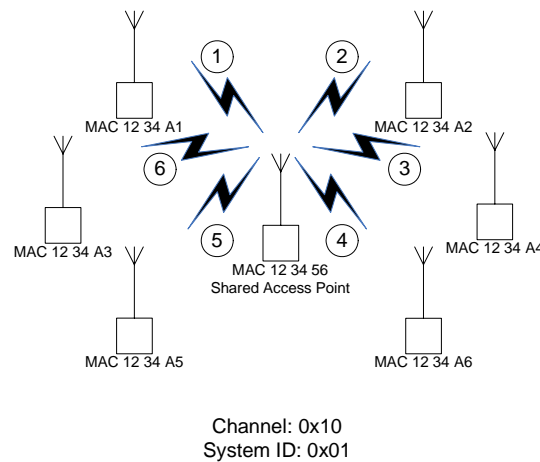

The simplest implementation consists of a smart Shared Access Point (SAP) with a microcontroller or processor of some type which has transmit API enabled. The SAP controls which transceiver(s) each packet is routed to. Broadcast packets should be used when all remotes are to receive the same message and addressed packets when communication with a single remote only is desired. An example of each is shown in the following pages.

Addressed Transmit API

- 1 To poll radio 1, the SAP transmits the packet using the following format:

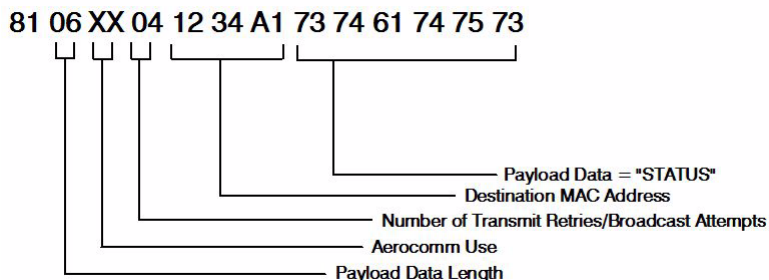

- 2 To poll radio 2, the SAP transmits the packet using the following format:

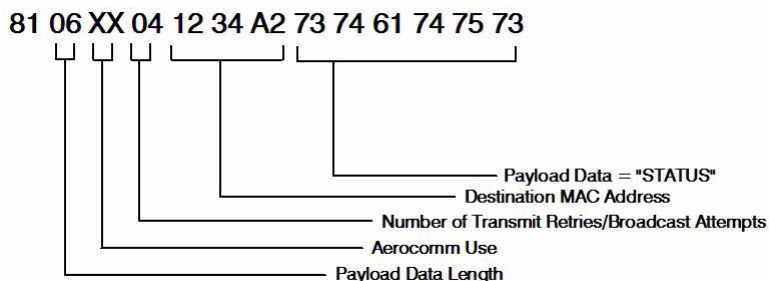

- 3 To poll radio 2, the SAP transmits the packet using the following format:

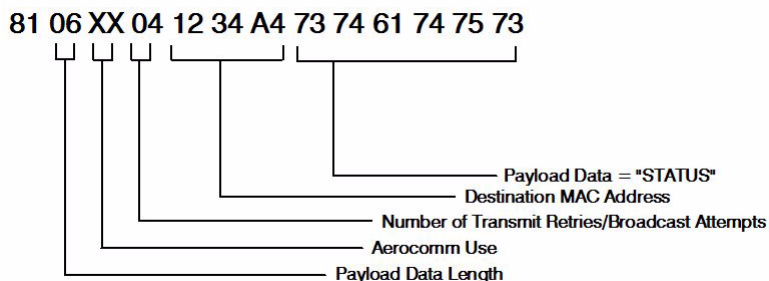

- 4 This continues until all radios have successfully been polled by the SAP.

Broadcast Transmit API

To send out a universal poll request or data packet, the OEM may wish to utilize the broadcast portion of the Transmit API command. The Broadcast command is similar to the addressed command; only with the Destination MAC Address set to all 0xFF.

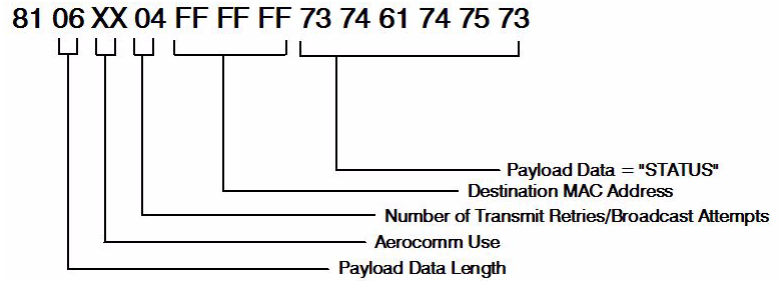

The remote response is dependent on the OEM's specific needs and equipment. In many cases, remote radios are connected to dumb devices without the intelligence to filter out or append specific portions of a packet that is transmitted or received. Since the 7 bytes of overhead in the Transmit API command are not sent over the RF, the remotes will receive only the payload data, "STATUS". If auto destination is enabled on the remote radio, the transceiver will automatically change its destination address to that of the radio it last received a packet from. When the remote device sends its response, it will therefore automatically be routed back to the SAP.

Depending on the API configuration of the SAP, the packet will be received in one of two formats:

Receive API

When Receive API is enabled, the transceiver will receive the reply data + the MAC address of the source radio. When Receive API is enabled, every packet received by the transceiver will be sent to the Host in the following format.

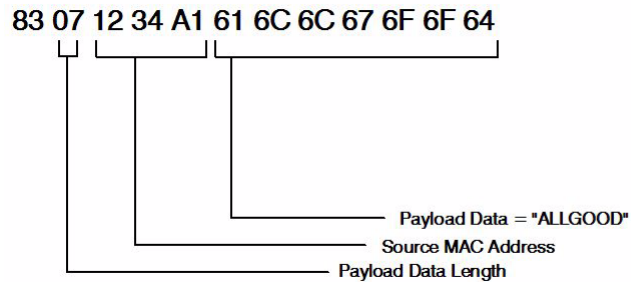

Enhanced Receive API

When Enhanced Receive API is enabled, the transceiver will receive the reply data + the MAC address of the source radio and one RSSI value; RSSI* is how strong the local heard the remote transceiver.

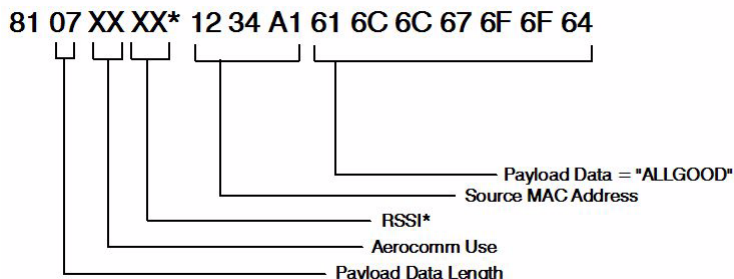

It may be useful to the OEM Host to determine which radio each packet originated from. When Enhanced Receive API is enabled, every packet received by the transceiver will be received in the above format.

Normal Receive Mode (non-API)

If Receive API is not enabled, the transceiver will receive the reply data only (i.e. "ALLGOOD") from each transceiver.

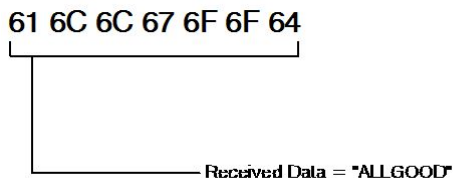

LOOPBACK REPEATER

The simplest repeater to implement is a loopback repeater. A loopback repeater can be created by connecting the transceiver's RXD and TXD lines together. When the radio receives data, it will retransmit the data to all available transceivers on the network. It is important not to have two loopback repeaters in range of each other as they will continuously transmit data back and forth.

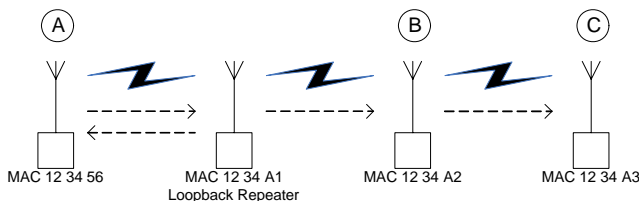

If radios B & C in the above picture are not within range of radio A, they will not be able to receive or respond to communications from radio A. A loopback repeater can be added between the three such that it is in range of both radio A and radios B & C. When the repeater receives a packet from radio A, it will transmit the packet out to radios B

& C. If the repeater is set to Broadcast mode, radio A will receive a copy of each packet that it sends. If the repeater has a specific destination address (i.e. 12 34 A2), then radio A will not receive the packet as its MAC address will not match the specified destination address.

TIME DIVISION MULTIPLE ACCESS NETWORK

For a more intelligent network, a TDMA system can be implemented. In this system various radios transmit data to a Shared Access Point (SAP) during an assigned time interval. The system is synchronous so that only one radio is transmitting at a time and has full access to the SAP's bandwidth. In a TDMA network, each radio must store its data for the amount of time between its transmissions or bursts. A typical format for data passing through a SAP is shown below. A frame consists of arriving bursts from remote radios and each frame is then divided into multiple time slots. The bursts can be of varying lengths and can be longer for heavy-traffic stations. To prevent overlaps, guard intervals can be inserted to absorb small timing errors in burst arrivals.

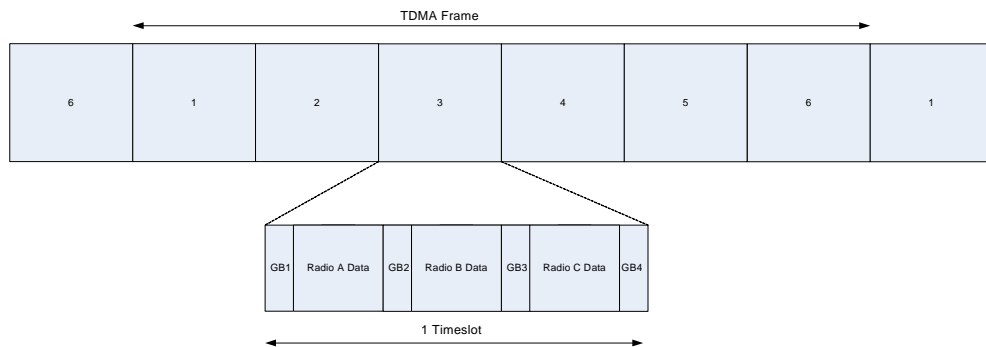

Example:

- **Shared Access Point (SAP) sends broadcast packet which includes a sync pulse**
- **Remote radios hear the sync pulse and join the session**
- **Radio A transmits during time interval $t = 1$**
- **Radio B transmits during time interval $t = 2$**
- **Radio N transmits during time interval $t = N - 1$**

This type of implementation requires careful planning and should allow enough time for retries if necessary. When full duplex is enabled, the radio which initiated the Session (SAP) will transmit during the even numbered hops and the remote radios will transmit only during odd numbered hops.

APPENDIX IV - SYNC TO CHANNEL

SYNC TO CHANNEL

What is it and do I need it?

AeroComm uses frequency hopping protocol with a fixed pseudo-random hopping sequence on our transceivers. This protocol yields superior interference rejection and multipath immunity. The Server radio sends timing beacons out on a regular interval and the Clients hear these beacons and synchronize their frequency hopping to the Server.

Though Servers cannot send packets to each other, they can hear the timing beacons sent out by other Servers. Normally, they simply ignore the beacons sent out by the other Servers. However, when Sync-to-Channel is enabled, they will listen for the beacons sent out by another Server and then synchronize their hop timing to that Server.

Why is this important? If two Servers (and their Clients) are operating in the same area and their frequency hopping is not synchronized to each other it's possible that they might try to occupy the same frequency at the same time. In severe cases, they could interfere with each other on every frequency, causing very sluggish communications.

To avoid this kind of interference, collocated Servers can use Sync-to-Channel. Sync-to-Channel synchronizes the frequency hop timing between these Servers so that they never occupy the same frequency at the same time.

To use Sync-to-Channel, you should select one Server (preferably the most centrally located Server) to be the "Hop Master." This Server should be programmed to a numerically low Channel Number and should have Sync-to-Channel disabled. All other Servers in the area should have Sync-to-Channel enabled. These other Servers should have Sync-Channel set to the Channel of another Server in the area that they are in range of. Preferably, if all Servers are in range of the Hop Master, they should all have their Sync-Channel set to the Channel Number of the Hop Master. The following rules apply to Sync-to-Channel:

One Server should perform the function of Hop Master. It should have its Channel Number set to a numerically low value and should have Sync-to-Channel disabled. It's preferable that it be centrally located. All other Servers in the area should have Sync-to-Channel enabled. They should have their Sync-Channel set to a value lower than their Channel Number. If they are in range of the Hop Master, it's preferable that they have the Sync-Channel set to the Channel Number of the Hop Master.

All collocated Servers must be programmed to the same Channel Set. There are 56 available channels for the AC4490, shown in Table 19 below.

Table 20: RF Channels for AC4490

Channel Set ¹	RF Channel Number Range (0x40)	Frequency Details & Regulatory requirements	Countries
0 (AC4490 - 1x1 AC4490 - 200)	0x00 - 0x0F	902 - 928 MHz (26 hop bins)	US / Canada
1 (AC4490 - 1x1 AC4490 - 1000)	0x10 - 0x2F	902 - 928 MHz (50 hop bins)	US / Canada
2 (AC4490 - 1x1 AC4490 - 200 AC4490 - 1000)	0x30 - 0x37	915 - 928 MHz (22 hop bins)	US / Canada (-1x1 / -200) Australia(-1x1/-200/-1000)

1. All collocated Servers must operate in the same Channel Set.

What happens if you don't enable Sync-to-Channel and you have collocated Servers? You have good odds that you will see a decrease in throughput due to the systems trying to occupy the same frequency at the same time. In severe cases, you could lose communications all together depending on how much bandwidth your system requires. Due to crystal differences between the Servers, you could see the interference come and go.

Figure 14: Servers without Sync-to-Channel Enabled

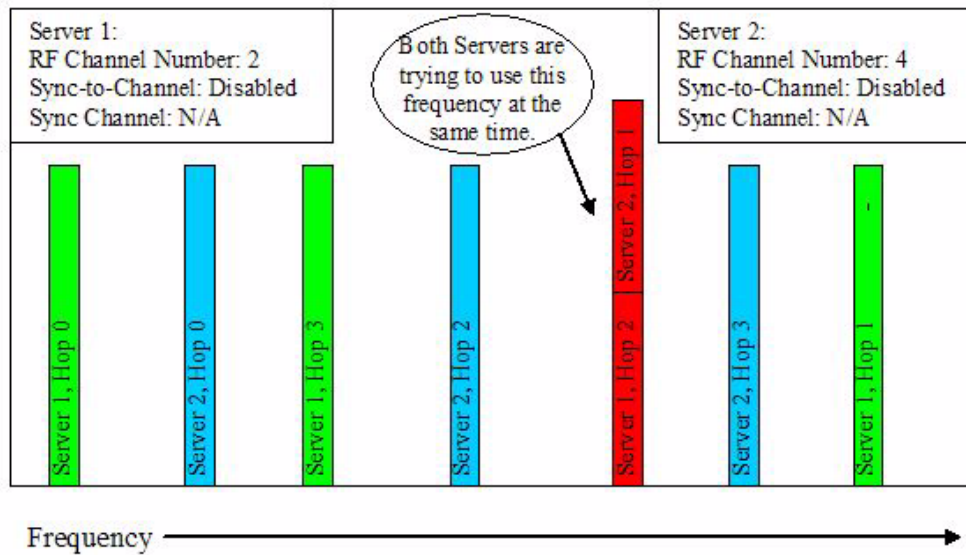
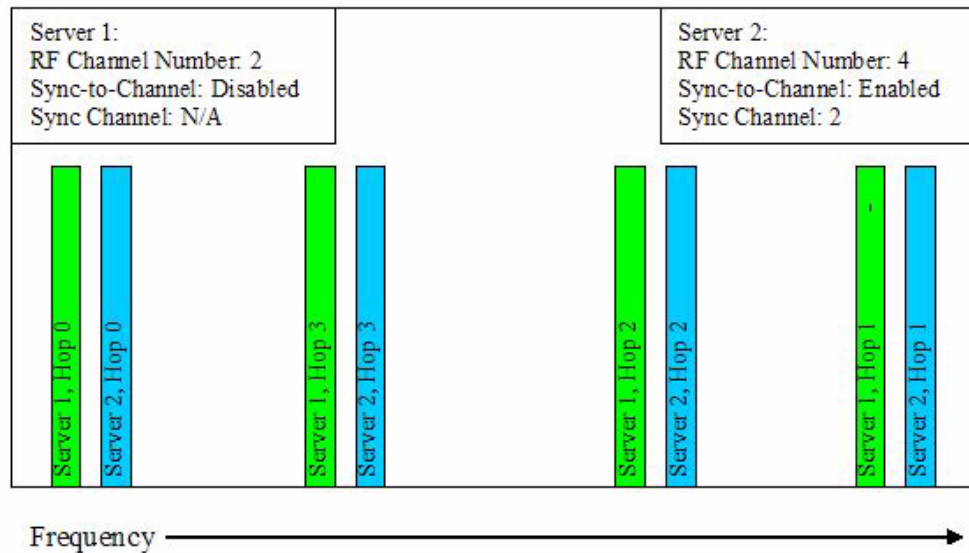

Figure 15: Servers with Sync-to-Channel Enabled**How do I configure Sync to Channel?**

To configure sync to channel, you must use our OEM configuration software. This can be downloaded from our website <http://www.aerocomm.com> by clicking the software link at the top of the screen and selecting the Developer Kit Software.

You will be prompted to install the software on your PC. Once the install is completed, you can open the software from Start -> All Programs -> Aerocomm Wireless -> Aerocomm OEM.exe

1. The software will open and prompt you to select a product. Select AC4490 as the product on the PC settings page (Figure 16).
2. Verify that the Read/Write with AT commands box is checked.
3. Select the COM Port that your radio is connected to. If you are unsure, press the Find Ports button and the drop down list will be updated with available COM ports.
4. Select the baud rate that matches the baud rate that the radio is programmed to.

Figure 16: PC Settings Page

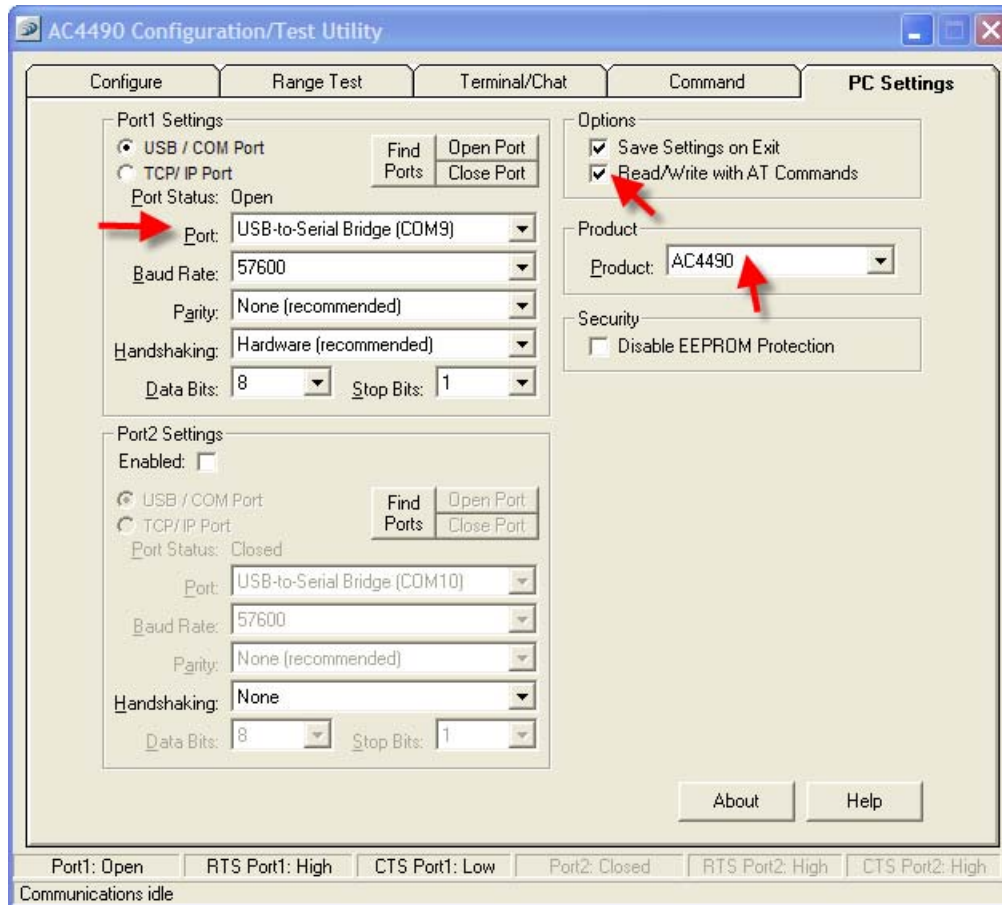

5. Go to the Configure page and click the read radio button at the bottom right of the screen. A message stating "Read Successful" should appear after a successful read (Figure 17).

Figure 17: Configure Page - Read Successful

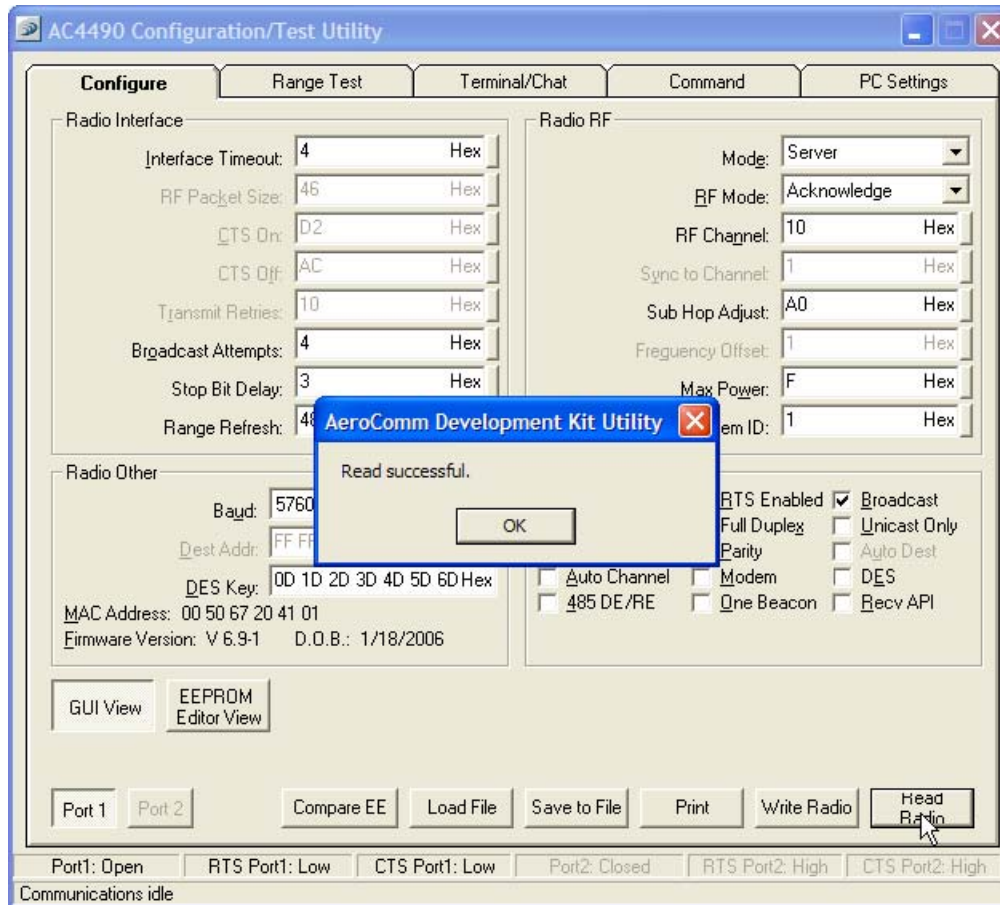

6. To configure the hop master, change the Mode to Server and select Broadcast. Make note of the RF Channel (Figure 18). Once the appropriate changes have been made, press the Write Radio button. A Write Successful prompt will appear after a successful write.

Figure 18: Hop Master Settings

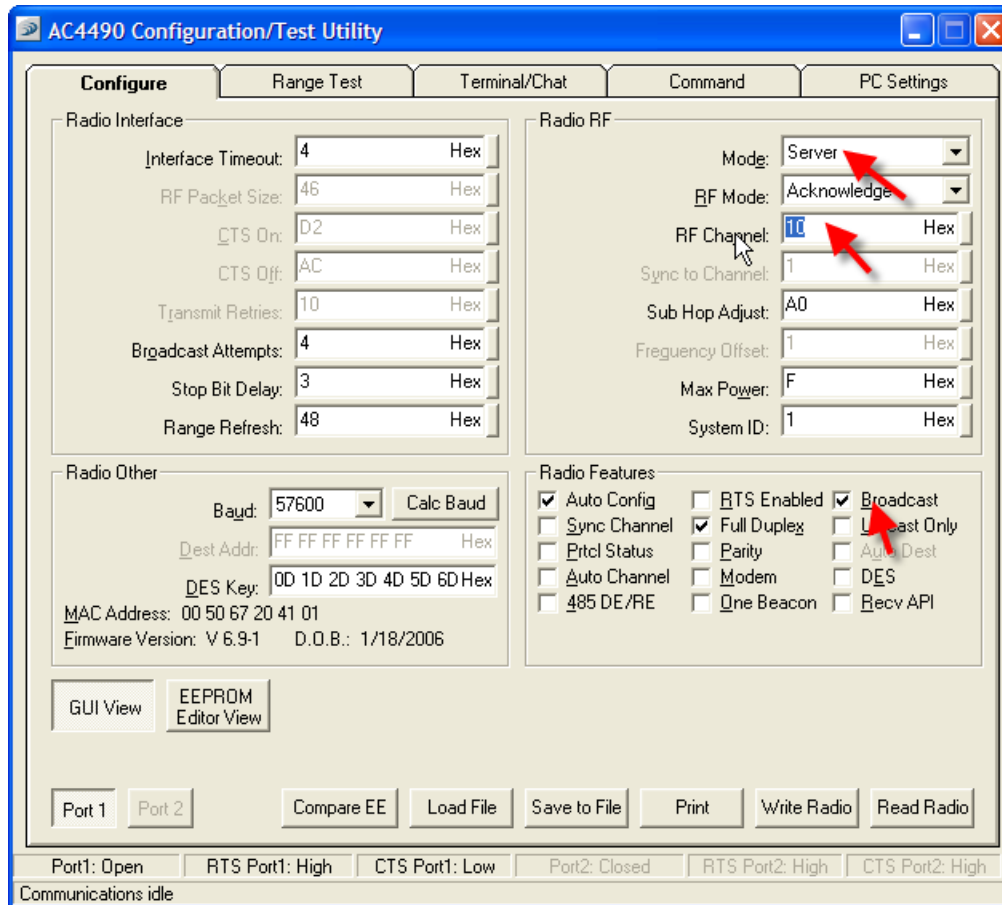

7. Configure all clients that will communicate with the hop master as Clients in Auto Destination and with the same RF channel as the hop master (Figure 19) and press the Write Radio button.

Figure 19: Client Settings

The screenshot shows the 'AC4490 Configuration/Test Utility' window with the 'Configure' tab selected. The interface is divided into several sections:

- Radio Interface:** Interface Timeout: 4 Hex, RF Packet Size: 46 Hex, CTS On: D2 Hex, CTS Off: AC Hex, Transmit Retries: 10 Hex, Broadcast Attempts: 4 Hex, Stop Bit Delay: 3 Hex, Range Refresh: 48 Hex.
- Radio RF:** Mode: Client, RF Mode: Acknowledge, RF Channel: 10 Hex, Sync to Channel: 1 Hex, Sub Hop Adjust: A0 Hex, Frequency Offset: 1 Hex, Max Power: F Hex, System ID: 1 Hex.
- Radio Other:** Baud: 57600, Dest Addr: FF FF FF FF FF Hex, DES Key: 0D 1D 2D 3D 4D 5D 6D Hex, MAC Address: 00 50 67 20 41 01, Firmware Version: V 6.9-1 D.O.B.: 1/18/2006.
- Radio Features:**
 - Auto Config
 - Sync Channel
 - Prtcl Status
 - Auto Channel
 - 485 DE/RE
 - RTS Enabled
 - Full Duplex
 - Parity
 - Modem
 - One Beacon
 - Broadcast
 - Unicast Only
 - Auto Dest
 - DES
 - Recv API

At the bottom, there are buttons for 'Port 1', 'Port 2', 'Compare EE', 'Load File', 'Save to File', 'Print', 'Write Radio', and 'Read Radio'. The status bar at the very bottom shows 'Port1: Open', 'RTS Port1: High', 'CTS Port1: Low', 'Port2: Closed', 'RTS Port2: High', 'CTS Port2: High', and 'Communications idle'.

8. Set the second server as a server in broadcast mode with an RF channel at least 2-5 steps above the RF channel of the hop master. Under the radio features section, select the Sync Channel box and in the Radio RF section, set the Sync to Channel to the RF channel of the hopmaster (Figure 20). Press the Write Radio button to write the changes to the radios EEPROM.

Figure 20: Server #2 Settings

The screenshot shows the 'AC4490 Configuration/Test Utility' window with the 'Configure' tab selected. The interface is divided into several sections:

- Radio Interface:** Contains fields for Interface Timeout (4), RF Packet Size (46), CTS On (D2), CTS Off (AC), Transmit Retries (10), Broadcast Attempts (4), Stop Bit Delay (3), and Range Refresh (48). Each field has a 'Hex' button.
- Radio RF:** Contains Mode (Server), RF Mode (Acknowledge), RF Channel (15), Sync to Channel (10), Sub Hop Adjust (A0), Frequency Offset (1), Max Power (F), and System ID (1). Red arrows point to Mode, RF Mode, RF Channel, and Sync to Channel.
- Radio Other:** Contains Baud (57600), Dest Addr (FF FF FF FF FF FF), DES Key (0D 1D 2D 3D 4D 5D 6D), MAC Address (00 50 67 20 41 01), and Firmware Version (V 6.9-1 D.O.B.: 1/18/2006). Includes 'Calc Baud' and 'EEPRM Editor View' buttons.
- Radio Features:** A grid of checkboxes including Auto Config, Sync Channel, RTS Enabled, Full Duplex, Broadcast, Priority Status, Parity, Auto Dest, Auto Channel, Modem, DES, 485 DE/RE, One Beacon, and Recv API.

At the bottom, there are buttons for 'Port 1', 'Port 2', 'Compare EE', 'Load File', 'Save to File', 'Print', 'Write Radio', and 'Read Radio'. A status bar at the very bottom shows 'Port1: Open', 'RTS Port1: High', 'CTS Port1: Low', 'Port2: Closed', 'RTS Port2: High', 'CTS Port2: High', and 'Communications idle'.

9. Configure the Clients that will communicate with Server #2 as Clients in Auto Destination and with the same RF channel as Server #2 (Figure 21). Press the Write Radio to write the changes to the radios EEPROM.

Figure 21: Client Settings

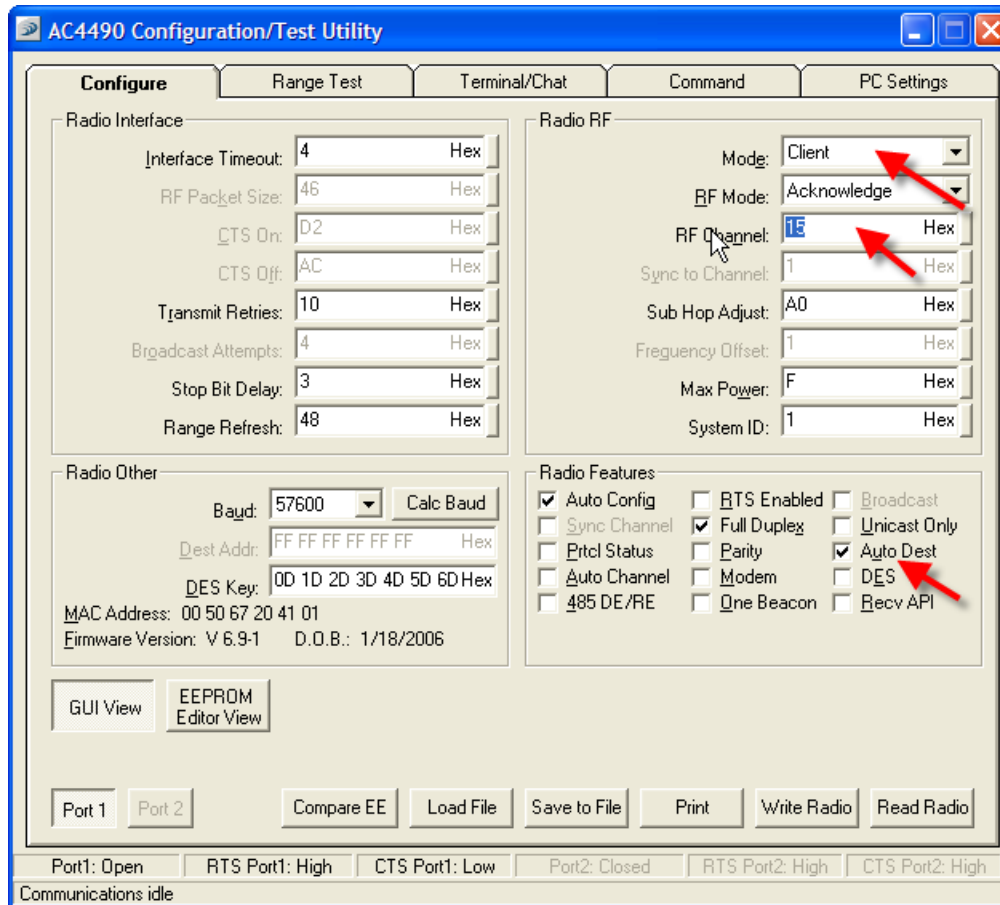

I've configured my radios, what's next?

Once you have configured all radios, your network should be setup similar to the one shown in Figure 22 below. The main server or hop master will need to be powered on anytime that the other servers are connected or they will never synchronize and will not be able to communicate with their clients. If a centralized network will not work and all servers will not be in range of the hop master, a daisy chain network can be utilized as shown in Figure 23.

Figure 22: Centralized Sync-to-Channel Configuration

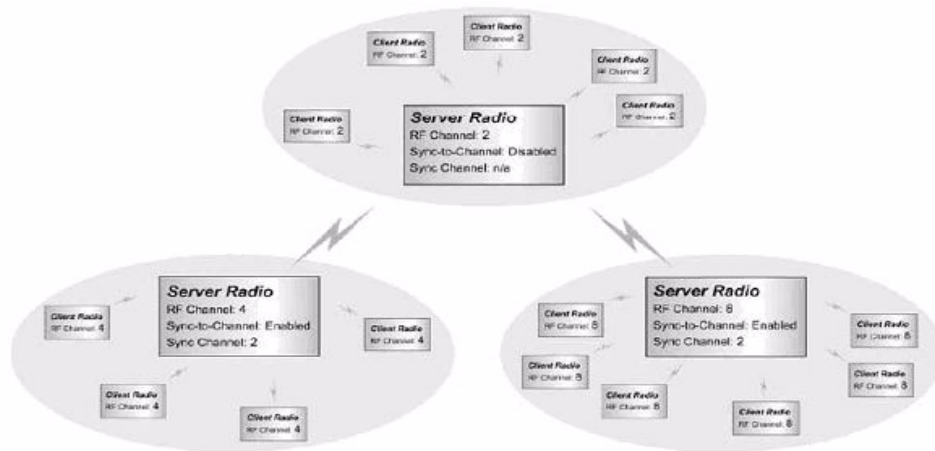

Figure 23: Daisy Chain Sync-to-Channel Configuration

