

---

## Integrated Transceiver Modules for WLAN 802.11 b/g/n, Bluetooth, Bluetooth Low Energy (BLE), and ANT

---

### FEATURES

- IEEE 802.11 a,b,g,n,d,e,l compliant
- Typical WLAN Transmit Power:
  - 18.3 dBm, 11 Mbps, CCK (b)
  - 14.4 dBm, 54 Mbps, OFDM (g)
  - 12.5 dBm, 65 Mbps, OFDM (n)
- Typical WLAN Sensitivity:
  - -88 dBm, 8% PER, 11 Mbps
  - -74 dBm, 10% PER, 54 Mbps
  - -72 dBm, 10% PER, 65 Mbps
- Bluetooth 2.1+EDR, Power Class 1.5
- Full support for BLE 4.0 and ANT
- Miniature footprint: 18 mm x 13 mm
- Low height profile: 1.9 mm
- Terminal for PCB/Chip antenna feeds
- Worldwide acceptance: FCC (USA), IC (Canada), and CE (Europe)
- Modular certification allows reuse of LSR FCC ID and ETSI certification without repeating the expensive testing on your end product
- Compact design based on Texas Instruments WL1273L Transceiver
- Seamless integration with TI OMAP™ application processors
- SDIO Host data path interfaces
- Bluetooth Advanced Audio Interfaces
- Low power operation modes
- RoHS compliant
- Streamlined development with LSR Design Services

### APPLICATIONS

- Security
- HVAC Control, Smart Energy
- Sensor Networks
- Medical

### DESCRIPTION

The TiWi5 module is a high performance 2.4 /5.5 GHz IEEE 802.11 a/b/g/n, Bluetooth 2.1+EDR, and Bluetooth Low Energy (BLE) 4.0 radio in a cost effective, pre-certified footprint.



The module realizes the necessary PHY/MAC layers to support WLAN applications in conjunction with a host processor over a SDIO interface.

The module also provides a Bluetooth platform through the UART or btSPI HCI transport layer. Both WLAN and Bluetooth share the same antenna port.

TiWi5 is pin for pin compatible with the TiWi-R2 and TiWi-BLE modules. TiWi5 does not include the on module U.FL connector.

Need to get to market quickly? Not an expert in 802.11 or Bluetooth? Need a custom antenna? Would you like to own the design? Would you like a custom design? Not quite sure what you need? Do you need help with your host board? LS Research Design Services will be happy to develop custom hardware or software, integrate the design, or license the design so you can manufacture yourself. Contact us at [sales@lsr.com](mailto:sales@lsr.com) or call us at 262-375-4400.



**ORDERING INFORMATION**

Order Number	Description
450-0053	TiWi5 Module (Tray, SPQ = 100)
450-0053R	TiWi5 Module (Tape and Reel, SPQ = 1000)

**Table 1 Orderable TiWi5 Part Numbers**

**MODULE ACCESSORIES**

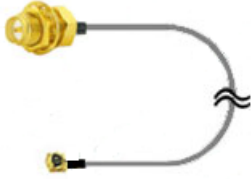
	Order Number	Description
	<b>001-0009</b>	2.4/5.5 GHz Dual-Band Dipole Antenna with Reverse Polarity SMA Connector
	<b>080-0001</b>	U.FL to Reverse Polarity SMA Bulkhead Cable 105mm

**Table 2 Module Accessories**

**BLOCK DIAGRAM**

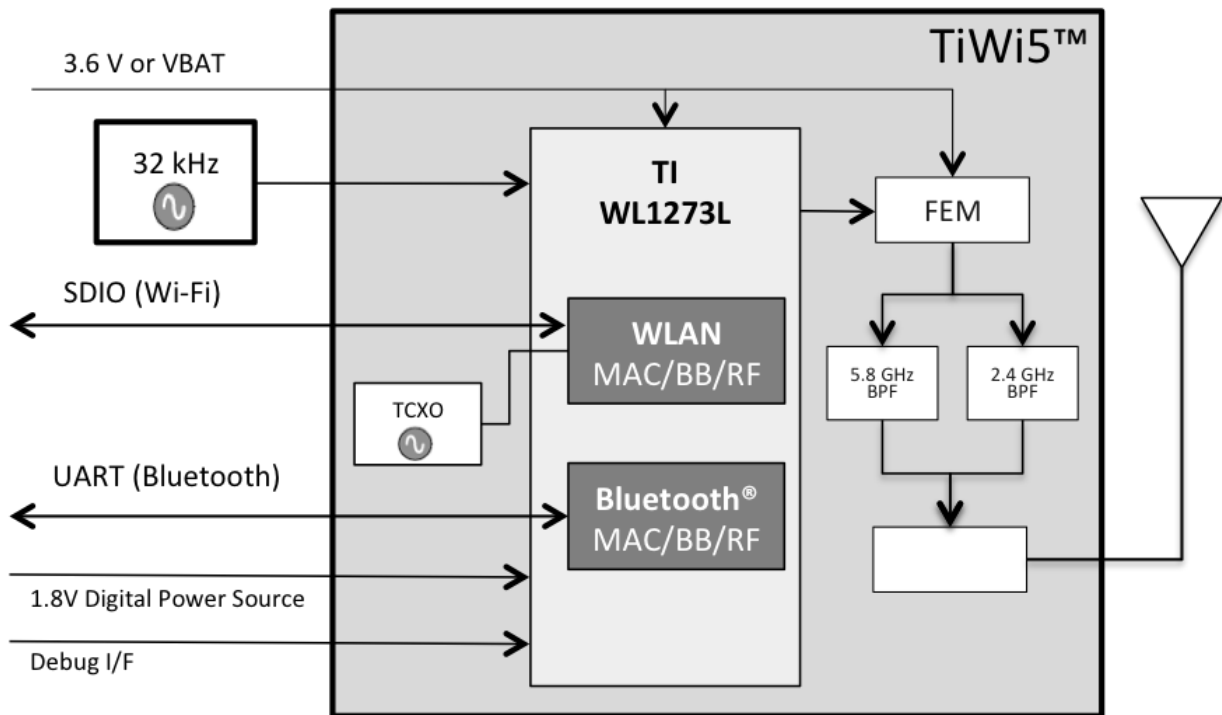

**Figure 1 TiWi5 Module Block Diagram – Top-Level**



**TABLE OF CONTENTS**

**FEATURES ..... 1**

**APPLICATIONS..... 1**

**DESCRIPTION ..... 1**

**ORDERING INFORMATION ..... 2**

**MODULE ACCESSORIES ..... 2**

**BLOCK DIAGRAM..... 3**

**PIN DESCRIPTIONS..... 7**

**INI FILE RADIO PARAMETERS..... 9**

**ELECTRICAL SPECIFICATIONS ..... 10**

**Absolute Maximum Ratings ..... 10**

**Recommended Operating Conditions ..... 10**

**General Characteristics ..... 11**

**WLAN RF Characteristics..... 14**

**Bluetooth RF Characteristics ..... 16**

**Bluetooth Low Energy RF Characteristics ..... 17**

**WLAN POWER-UP SEQUENCE ..... 18**

**WLAN POWER-DOWN SEQUENCE..... 19**

**BLUETOOTH POWER-UP SEQUENCE..... 20**

**BLUETOOTH POWER-DOWN SEQUENCE ..... 21**

**ENABLE SCHEME ..... 22**

**IRQ OPERATION..... 22**

**SLOW (32 KHZ) CLOCK SOURCE REQUIREMENTS ..... 23**

**BLUETOOTH HCI UART ..... 24**

**SDIO INTERFACE TIMING ..... 26**

**SDIO CLOCK TIMING..... 27**

**SOLDERING RECOMMENDATIONS ..... 28**

The information in this document is subject to change without notice.



---

Recommended Reflow Profile for Lead Free Solder .....	28
<b>CLEANING .....</b>	<b>29</b>
<b>OPTICAL INSPECTION .....</b>	<b>29</b>
<b>REWORK .....</b>	<b>29</b>
<b>SHIPPING, HANDLING, AND STORAGE .....</b>	<b>29</b>
Shipping .....	29
Handling .....	29
Moisture Sensitivity Level (MSL).....	29
Storage .....	29
Repeating Reflow Soldering .....	30
<b>AGENCY CERTIFICATIONS .....</b>	<b>31</b>
<b>AGENCY STATEMENTS .....</b>	<b>31</b>
Federal Communication Commission Interference Statement .....	31
Industry Canada Statements.....	32
<b>OEM RESPONSIBILITIES TO COMPLY WITH FCC AND INDUSTRY CANADA REGULATIONS.....</b>	<b>33</b>
<b>OEM LABELING REQUIREMENTS FOR END-PRODUCT .....</b>	<b>34</b>
<b>OEM END PRODUCT USER MANUAL STATEMENTS.....</b>	<b>35</b>
<b>EUROPE .....</b>	<b>36</b>
CE Notice .....	36
Declaration of Conformity (DOC) .....	36
<b>MECHANICAL DATA.....</b>	<b>37</b>
<b>PCB FOOTPRINT .....</b>	<b>38</b>
<b>TAPE AND REEL SPECIFICATION .....</b>	<b>39</b>
<b>DEVICE MARKINGS.....</b>	<b>40</b>
Rev 1 Devices .....	40
Rev 2 Devices .....	40
Rev 3 Devices .....	41
<b>CONTACTING LS RESEARCH .....</b>	<b>42</b>

---

The information in this document is subject to change without notice.

**TIWi5 MODULE FOOTPRINT AND PIN DEFINITIONS**

To apply the TiWi5 module, it is important to use the module pins in your application as they are designated in below and in the corresponding pin definition table found on pages 7 and 8. Not all the pins on the TiWi5 module may be used, as some are reserved for future functionality.

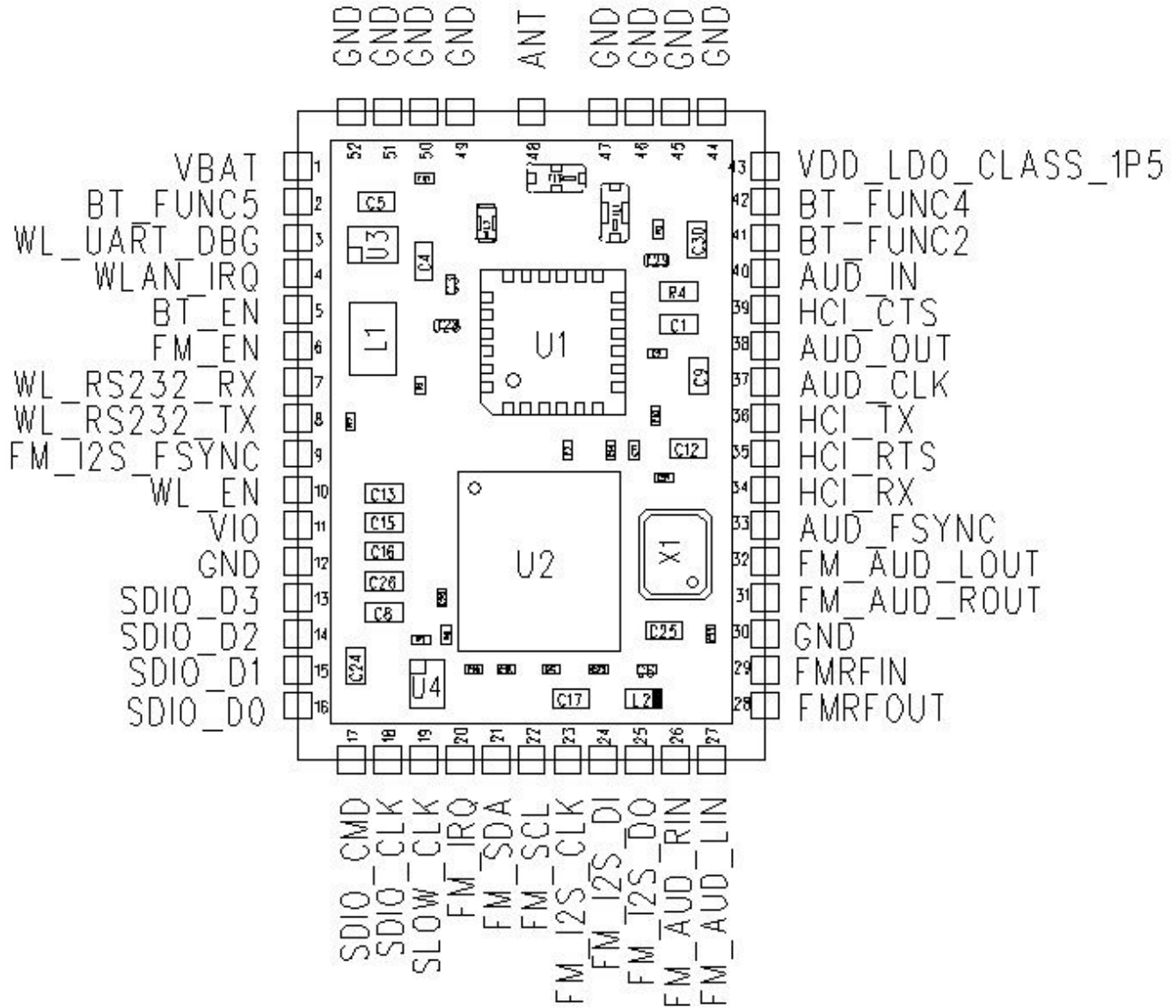

**Figure 2 TiWi5 Pinout (Top View)**

**PIN DESCRIPTIONS**

Module Pin	Name	I/O Type	Buffer Type	Logic Level	Description
1	VBAT	PI	-	-	Battery Voltage 3.6 VDC Nominal (3.0-4.8 VDC)
2	BT_FUNC5	DO	4 mA	1.8 VDC	HOST_WU (*)
3	WL_UART_DBG	DIO	4 mA	1.8 VDC	WL_UART_DBG
4	WLAN_IRQ	DO	4 mA	1.8 VDC	WLAN Interrupt Request
5	BT_EN	DI	-	1.8 VDC	Bluetooth Enable
6	FM_EN	DI	-	1.8 VDC	NOT SUPPORTED, CONNECT TO GND
7	WL_RS232_RX	DI	-	1.8 VDC	WLAN TEST UART RX (*)
8	WL_RS232_TX	DO	4 mA	1.8 VDC	WLAN TEST UART TX (*)
9	FM_I2S_FSYNC	DO	4 mA	1.8 VDC	NOT SUPPORTED, NO CONNECT
10	WL_EN	DI	-	1.8 VDC	WLAN Enable
11	VIO	PI	-	-	POWER SUPPLY FOR 1.8 VDC DIGITAL DOMAIN
12	GND	GND	-	-	Ground
13	SDIO_D3	DIO	8 mA	1.8 VDC	SDIO INTERFACE, HOST PULL UP
14	SDIO_D2	DIO	8 mA	1.8 VDC	SDIO INTERFACE, HOST PULL UP
15	SDIO_D1	DIO	8 mA	1.8 VDC	SDIO INTERFACE, HOST PULL UP
16	SDIO_D0	DIO	8 mA	1.8 VDC	SDIO INTERFACE, HOST PULL UP
17	SDIO_CMD	DIO	8 mA	1.8 VDC	HOST PULL UP
18	SDIO_CLK	DI	-	1.8 VDC	HOST PULL UP
19	SLOW_CLK	DI	-	1.8 VDC	SLEEP CLOCK (32 kHz)
20	FM_IRQ	DO	4 mA	1.8 VDC	NOT SUPPORTED, NO CONNECT
21	FM_SDA	DO	4 mA	1.8 VDC	NOT SUPPORTED, NO CONNECT
22	FM_SCL	DO	4 mA	1.8 VDC	NOT SUPPORTED, NO CONNECT
23	FM_I2S_CLK	DO	4 mA	1.8 VDC	NOT SUPPORTED, NO CONNECT
24	FM_I2S_DI	DI	4 mA	1.8 VDC	NOT SUPPORTED, CONNECT TO GND
25	FM_I2S_DO	DO	4 mA	1.8 VDC	NOT SUPPORTED, NO CONNECT
26	FM_AUD_RIN	AI	-	-	NOT SUPPORTED, CONNECT TO GND
27	FM_AUD_LIN	AI	-	-	NOT SUPPORTED, CONNECT TO GND
28	FMRFOUT	AO	-	-	NOT SUPPORTED, NO CONNECT
29	FMRFIN	AI	-	-	NOT SUPPORTED, CONNECT TO GND
30	GND	GND	-	-	Ground
31	FM_AUD_ROUT	AO	-	-	NOT SUPPORTED, NO CONNECT

The information in this document is subject to change without notice.

Module Pin	Name	I/O Type	Buffer Type	Logic Level	Description
32	FM_AUD_LOUT	AO	-	-	NOT SUPPORTED, NO CONNECT
33	AUD_FSYNC	DIO	4 mA	1.8 VDC	PCM I/F
34	HCI_RX	DI	8 mA	1.8 VDC	Bluetooth HCI UART RX (*)
35	HCI_RTS	DO	4 mA	1.8 VDC	Bluetooth HCI UART RTS (*)
36	HCI_TX	DIO	8 mA	1.8 VDC	Bluetooth HCI UART TX
37	AUD_CLK	DO	4 mA	1.8 VDC	PCM I/F (*)
38	AUD_OUT	DO	4 mA	1.8 VDC	PCM I/F (*)
39	HCI_CTS	DI	4 mA	1.8 VDC	Bluetooth HCI UART CTS (*)
40	AUD_IN	DI	4 mA	1.8 VDC	PCM I/F (*)
41	BT_FUNC2	DI	4 mA	1.8 VDC	Bluetooth Wakeup / DC2DC mode (*)
42	BT_FUNC4	DO	4 mA	1.8 VDC	BT_UARTD (DEBUG) (*)
43	VDD_LDO_CLASS_1P5	NC	-	-	VBAT VOLTAGE PRESENT, NO CONNECT
44	GND	GND	-	-	Ground
45	GND	GND	-	-	Ground
46	GND	GND	-	-	Ground
47	GND	GND	-	-	Ground
48	ANT	RF		-	Antenna terminal for WLAN and Bluetooth (note [1])
49	GND	GND	-	-	Ground
50	GND	GND	-	-	Ground
51	GND	GND	-	-	Ground
52	GND	GND	-	-	Ground

PI = Power Input    PO = Power Output    DI = Digital Input (1.8 VDC Logic Level)    DO = Digital Output (1.8 VDC Logic Level)  
 AI = Analog Input    AO = Analog Output    AIO = Analog Input/Output    RF = RF Port    GND = Ground

Note[1]: Antenna terminal presents DC short circuit to ground.

(\*) indicates that pin is capable of bidirectional operation, but is used as the type shown.

**Table 3 TiWi5 Module Pin Descriptions**

**All digital I/O signals use 1.8V logic. If the host microcontroller does not support 1.8V logic, then level shifters MUST be used.**



## **INI FILE RADIO PARAMETERS**

There is an ini file that contains WLAN radio parameters which are critical to both the RF performance and EMC compliance of the module.

The ini file available on the LSR wiki is only intended to be used with the LSR WLAN Eval Tool. Note that this ini file will not work when using the TiWi5 module in normal operation which typically involves an operating system. To use the TiWi5 module in normal operation, refer to specifics contained in the TiWi Family INI File Radio Parameter User Guide which is also available for download on the LSR website.

The settings specified in the appropriate ini file must be used to operate the module in compliance with the modular certification for FCC or ETSI. There is a unique ini file for operating the module in compliance with FCC regulations, and a different ini file for operating the module in compliance with the ETSI regulations.

## ELECTRICAL SPECIFICATIONS

The majority of these characteristics are based on controlling and conditioning the tests using the TiWi5 control software application. Other control conditions may require these values to be re-characterized by the customer.

### Absolute Maximum Ratings

Parameter	Min	Max	Unit
Power supply voltage (VBAT) <sup>(4)(5)</sup>	-0.5	+5.5	V
Digital supply voltage (VIO)	-0.5	2.1	V
Voltage on any GPIO	-0.5	VIO + 0.5	V
Voltage on any Analog Pins <sup>(3)</sup>	-0.5	2.1	V
RF input power, antenna port		+10	dBm
Operating temperature <sup>(6)</sup>	-40	+85	°C
Storage temperature	-55	+125	°C

- Stresses beyond those listed under “absolute maximum ratings” may cause permanent damage to the device and are not covered by the warranty. These are stress ratings only and functional operation of the device at these or any other conditions beyond those indicated under “recommended operating conditions” is not implied. Exposure to absolute-maximum-rated conditions for extended periods may affect device reliability.
- All parameters are measured as follows unless stated otherwise: VDD\_IN=1.8V, VDDIO\_1.8V=1.8V, VDD\_LDO\_CLASS1P5=3.6V
- Analog pins: XTALP, XTALM, RFIOBT, DRPWRXBM, DRPWRXBP, DRPWTXB, and also FMRFINP, FMRFINM, FMRFINM, FMAUDLIN, FMAUDRIN, FMAUDLOUT, FMAUDROUT
- The following signals are from the VBAT group, PMS\_VBAT and VDD\_LDO\_CLASS1P5 (if BT class 1.5 direct VBAT is used).
- Maximum allowed depends on accumulated time at that voltage; 4.8V for 7 years lifetime, 5.5V for 6 hours cumulative.
- The device can be reliably operated for 5,000 active-WLAN cumulative hours at T<sub>A</sub> of 85°C.

**Table 4 Absolute Maximum Ratings**

### Recommended Operating Conditions

Parameter	Min	Typ	Max	Unit
V <sub>BAT</sub>	3.0	3.6	4.8	V
VIO	1.62	1.8	1.92	V
V <sub>IH</sub>	0.65 x VIO	-	VIO	V
V <sub>IL</sub>	0	-	0.35 x VIO	V
V <sub>OH</sub> @ 4, 8 mA	VIO - 0.45	-	VIO	V
V <sub>OL</sub> @ 4, 8 mA	0	-	0.45	V
Ambient temperature range	-40	25	85	°C

**Table 5 Recommended Operating Conditions**

The information in this document is subject to change without notice.

### General Characteristics

Parameter	Min	Typ	Max	Unit
WLAN RF frequency range 1	2412		2472	MHz
WLAN RF frequency range 2	4910		5835	MHz
WLAN RF data rate	1	802.11 a/b/g/n rates supported	65	Mbps
BT RF frequency Range	2402		2480	MHz

**Table 6 General Characteristics**

### Power Consumption – WLAN 2.4 GHz

Parameter	Test Conditions	Min	Typ	Max	Unit
CCK (802.11b) TX Current	2437 MHz, $V_{BAT}=3.6V$ , $T_{amb}=+25^{\circ}C$ $P_o=18.3$ dBm, 11 Mbps CCK $L=1200$ bytes, $t_{delay}$ (idle)=4 $\mu S$	-	247	-	mA
OFDM (802.11g) TX Current	2437 MHz, $V_{BAT}=3.6V$ , $T_{amb}=+25^{\circ}C$ $P_o=14.4$ dBm, 54 Mbps OFDM $L=1200$ bytes, $t_{delay}$ (idle)=4 $\mu S$	-	180	-	mA
OFDM (802.11n) TX Current	2437 MHz, $V_{BAT}=3.6V$ , $T_{amb}=+25^{\circ}C$ $P_o=12.5$ dBm, 65 Mbps OFDM $L=1200$ bytes, $t_{delay}$ (idle)=4 $\mu S$	-	166	-	mA
CCK (802.11b) RX Current		-	93	-	mA
OFDM (802.11g) RX Current		-	93	-	mA
OFDM (802.11n) RX Current		-	93	-	mA
Dynamic Mode [1]		-	<1.2	-	mA

[1] Total Current from  $V_{BAT}$  for reception of Beacons with DTIM=1 TBTT=100 mS, Beacon duration 1.6ms, 1 Mbps beacon reception in Listen Mode.

**Table 7 2.4 GHz WLAN Power Consumption**

**Power Consumption – WLAN 5 GHz**

Parameter	Test Conditions	Min	Typ	Max	Unit
OFDM 9 Mbps (802.11a) TX Current	5745 MHz, $V_{BAT} = 3.6V$ , $T_{amb} = +25^{\circ}C$ $P_o = 17.6$ dBm, 9 Mbps OFDM $L = 1200$ bytes, $t_{delay} (idle) = 4 \mu S$	-	296	-	mA
OFDM 54 Mbps (802.11a) TX Current	5745 MHz, $V_{BAT} = 3.6V$ , $T_{amb} = +25^{\circ}C$ $P_o = 15.0$ dBm, 54 Mbps OFDM $L = 1200$ bytes, $t_{delay} (idle) = 4 \mu S$	-	235	-	mA
MCS0 6.5 Mbps (802.11a) TX Current	5745 MHz, $V_{BAT} = 3.6V$ , $T_{amb} = +25^{\circ}C$ $P_o = 18.0$ dBm, MCS0 OFDM $L = 1200$ bytes, $t_{delay} (idle) = 4 \mu S$	-	298	-	mA
MCS7 65 Mbps (802.11a) TX Current	5745 MHz, $V_{BAT} = 3.6V$ , $T_{amb} = +25^{\circ}C$ $P_o = 13.2$ dBm, MCS7 OFDM $L = 1200$ bytes, $t_{delay} (idle) = 4 \mu S$	-	219	-	mA
54/65 Mbps (802.11a/n) RX Current		-	100	-	mA
Dynamic Mode [1]		-	<1.2	-	mA

[1] Total Current from  $V_{BAT}$  for reception of Beacons with DTIM=1 TBTT=100 mS, Beacon duration 1.6ms, 1 Mbps beacon reception in Listen Mode.

**Table 8 5 GHz WLAN Power Consumption**

**Power Consumption - Bluetooth**

Parameter	Test Conditions	Min	Typ	Max	Unit
GFSK TX Current	Constant Transmit, 1DH5, PRBS9	-	45	-	mA
EDR TX Current	Constant Transmit, 2DH5,3DH5, PRBS9	-	43	-	mA
GFSK RX Current	Constant Receive, 1DH1	-	35	-	mA
EDR RX Current	Constant Receive, 2DH5, 3DH5	-	41	-	mA
Deep Sleep Current	Deep Sleep Mode	-	70	-	μA

**Table 9 Bluetooth Power Consumption**
**DC Characteristics – General Purpose I/O**

Parameter	Test Conditions	Min	Typ	Max	Unit
VIO Current			-	16	mA
Logic input low, $V_{IL}$		0	-	0.35 x VIO	V
Logic input high, $V_{IH}$		0.65 x VIO	-	VIO	V
Logic output low, $V_{OL}$ (Full Drive)	Iout = 8 mA	0	-	0.45	V
	Iout = 4 mA	0	-	0.45	V
Logic output low, $V_{OL}$ (Reduced Drive)	Iout = 1 mA	0	-	0.112	V
	Iout = 0.09 mA	0	-	0.01	V
Logic output high, $V_{OH}$ (Full Drive)	Iout = -8 mA	VIO - 0.45	-	VIO	V
	Iout = -4 mA	VIO - 0.45	-	VIO	V
Logic output high, $V_{OH}$ (Reduced Drive)	Iout = -1 mA	VIO - 0.112	-	VIO	V
	Iout = -0.3 mA	VIO - 0.033	-	VIO	V

**Table 10 DC Characteristics General Purpose I/O**

**WLAN RF Characteristics**

**WLAN Transmitter Characteristics 2.4 GHz  
(TA=25°C, VBAT=3.6 V)**

Parameter	Test Conditions	Typ EVM	Min	Typ	Max	Unit
11 Mbps CCK (802.11b) TX Output Power	11 Mbps CCK , 802.11(b) Mask Compliance, 35% EVM RMS power over TX packet	1.1	-	18.3	-	dBm
9 Mbps OFDM (802.11g) TX Output Power	9 Mbps OFDM , 802.11(g) Mask Compliance, -8 dB EVM RMS power over TX packet	-24	-	18.0	-	dBm
54 Mbps OFDM (802.11g) TX Output Power	54 Mbps OFDM, 802.11(g) Mask Compliance, -25 dB EVM RMS power over TX packet	-34	-	14.4	-	dBm
6.5 Mbps OFDM (802.11n) TX Output Power	6.5 Mbps OFDM, 802.11(n) Mask Compliance, -5 dB EVM RMS power over TX packet	-24	-	18.2	-	dBm
65 Mbps OFDM (802.11n) TX Output Power	65 Mbps OFDM, 802.11(n) Mask Compliance, -28 dB EVM RMS power over TX packet	-35	-	12.5	-	dBm

**Table 11 WLAN 2.4 GHz Transmitter RF Characteristics**

**WLAN Transmitter Characteristics 5 GHz  
(TA=25°C, VBAT=3.6 V)**

Parameter	Test Conditions	Typ EVM	Start Freq	Min	Typ	Max	End Freq	Unit
9 Mbps TX Output Power	9 Mbps OFDM , 802.11(a) Mask Compliance, -8 dB EVM RMS power over TX packet	-31	5170	-	13.0	-	5240	dBm
		-28	5260		15.6		5700	
		-21	5745		17.8		5825	
54 Mbps TX Output Power	54 Mbps OFDM , 802.11(a) Mask Compliance, -25 dB EVM RMS power over TX packet	-31	5170	-	13.0	-	5240	dBm
		-30	5260		14.6		5700	
		-28	5745		15.2		5825	
MCS0 6.5 Mbps TX Output Power	MCS0 OFDM , 802.11(a) Mask Compliance, -5 dB EVM RMS power over TX packet	-31	5170	-	13.1	-	5240	dBm
		-28	5260		15.7		5700	
		-21	5745		18.2		5825	
MCS7 65 Mbps TX Output Power	MCS7 OFDM , 802.11(a) Mask Compliance, -27 dB EVM RMS power over TX packet	-31	5170	-	12.5	-	5240	dBm
		-31	5260		12.8		5700	
		-29	5745		13.5		5825	

**Table 12 WLAN 5 GHz Transmitter RF Characteristics**

The information in this document is subject to change without notice.

**WLAN Receiver Characteristics 2.4 GHz  
(TA=25°C, VBAT=3.6 V) [1]**

Parameter	Test Conditions	Min	Typ	Max	Unit
1 Mbps CCK (802.11b) RX Sensitivity	8% PER	-	-97	-	dBm
11 Mbps CCK (802.11b) RX Sensitivity	8% PER	-	-88	-	dBm
9 Mbps OFDM (802.11g) RX Sensitivity	10% PER	-	-89	-	dBm
54 Mbps OFDM (802.11g) RX Sensitivity	10% PER	-	-74	-	dBm
6.5 Mbps OFDM (802.11n) RX Sensitivity	10% PER	-	-89	-	dBm
65 Mbps OFDM (802.11n) RX Sensitivity	10% PER	-	-72	-	dBm
11 Mbps CCK (802.11b) RX Overload Level	8% PER	-	-	-10	dBm
9 Mbps OFDM (802.11g) RX Overload Level	10% PER	-	-	-17	dBm
54 Mbps OFDM (802.11g) RX Overload Level	10% PER	-	-	-17	dBm
65 Mbps OFDM (802.11n) RX Overload Level	10% PER	-	-	-17	dBm

[1] Up to 2 dB degradation at Channel 13 for 11g/n modes and up to 2 dB degradation at Channel 14 for 11b/g/n modes.

**Table 13 2.4 GHz WLAN Receiver RF Characteristics**
**WLAN Receiver Characteristics 5 GHz  
(TA=25°C, VBAT=3.6 V) [1]**

Parameter	Test Conditions	Min	Typ	Max	Unit
9 Mbps (802.11a) RX Sensitivity	10% PER	-	-87	-	dBm
54 Mbps (802.11a) RX Sensitivity	10% PER	-	-72	-	dBm
MCS0 6.5 Mbps (802.11a) RX Sensitivity	10% PER	-	-88	-	dBm
MCS7 65 Mbps (802.11a) RX Sensitivity	10% PER	-	-70	-	dBm
Max Input Level (3) OFDM (11a or 11n)	<10% PER	-	-	-17	dBm

**Table 14 5 GHz WLAN Receiver RF Characteristics**

The information in this document is subject to change without notice.

## Bluetooth RF Characteristics

### Bluetooth Transmitter GFSK and EDR Characteristics, Class 1.5 (TA=25°C, VBAT=3.6 V)

Parameter	Test Conditions	Min	Typ	Max	Bluetooth Spec	Unit
GFSK RF Output Power		-	9.5	-	-	dBm
EDR RF Output Power		-	7.3	-		dBm
Power Control Step Size		2	5	8	2-8	dB
EDR Relative Power		-2		1	-4/+1	dB

**Table 15 Bluetooth Transmitter RF Characteristics**

### Bluetooth Receiver Characteristics (TA=25°C, VBAT=3.6 V)

Parameter	Test Conditions	Min	Typ	Max	Bluetooth Spec	Unit
GFSK Sensitivity	BER=0.1%	-	-91	-	-70	dBm
EDR 2 Mbps Sensitivity	BER=0.01%	-	-90	-	-70	dBm
EDR 3 Mbps Sensitivity	BER=0.01%	-	-83	-	-70	dBm
GFSK Maximum Input Level	BER=0.1%	-	-	-5	-20	dBm
EDR 2 Maximum Input Level	BER=0.1%	-	-	-10	-	dBm
EDR 3 Maximum Input Level	BER=0.1%	-	-	-10	-	dBm

**Table 16 Bluetooth Receiver RF Characteristics**



## Bluetooth Low Energy RF Characteristics

### Bluetooth BLE Transmitter GMSK and EDR Characteristics, Class 1.5 (TA=25°C, VBAT=3.6 V)

Parameter	Test Conditions	Min	Typ	Max	Bluetooth Spec	Unit
GMSK RF Output Power		-	10	-	-	dBm
Power Control Step Size		2	5	8	2-8	dB

(1) BLE spec = 10dBm max can be achieved using normal system losses due to filters etc, or by reducing value through VS command.

**Table 17 Bluetooth Low Energy Transmitter RF Characteristics**

### Bluetooth BLE Receiver Characteristics (TA=25°C, VBAT=3.6 V)

Parameter	Test Conditions	Min	Typ	Max	Bluetooth Spec	Unit
GMSK Sensitivity	PER = 30.8%	-	-90	-	-70	dBm
GMSK Maximum Input Level	PER = 30.8%	-	-5	-	-20	dBm

**Table 18 Bluetooth Low Energy Receiver RF Characteristics**

## WLAN POWER-UP SEQUENCE

The following sequence describes device power-up from shutdown. Only the WLAN Core is enabled; the Bluetooth and FM cores are disabled.

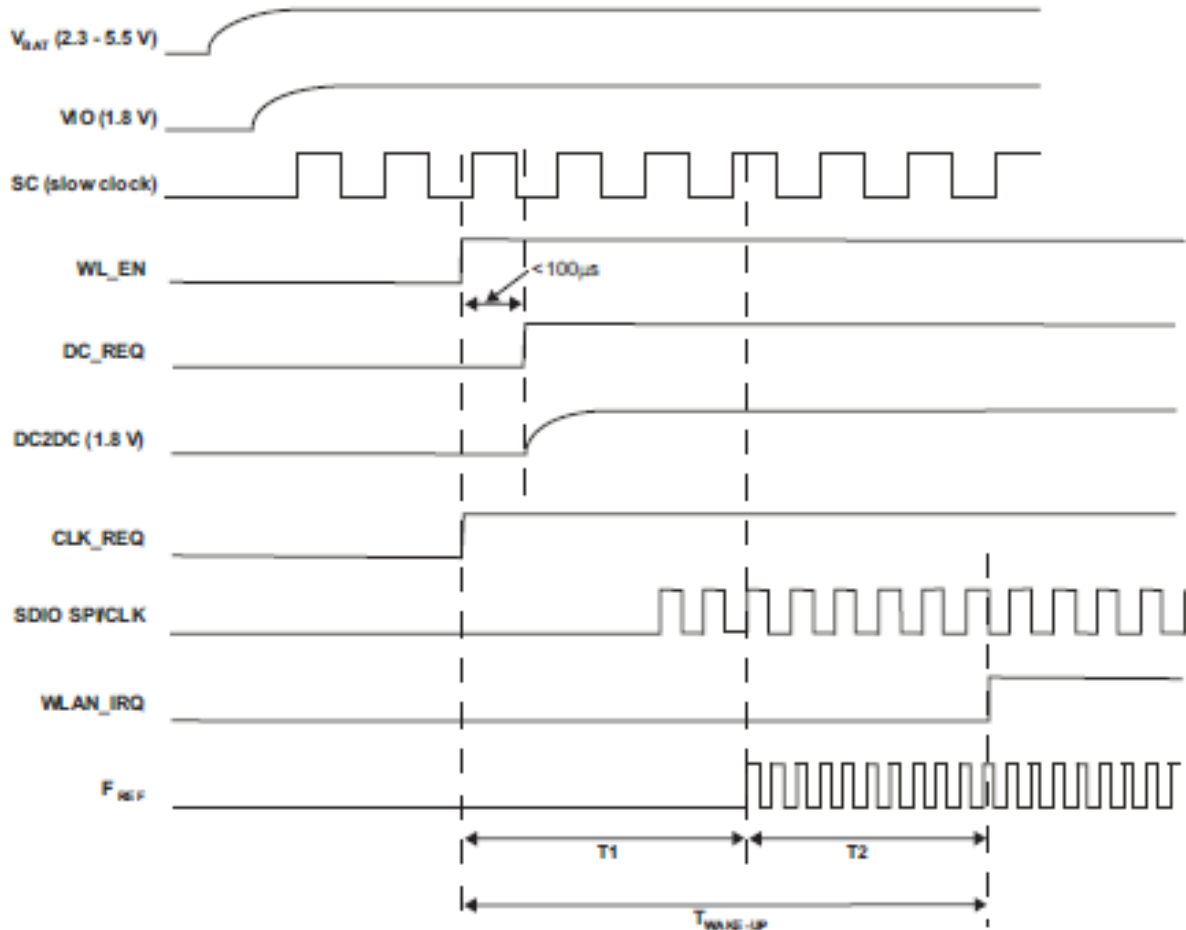

**Figure 3 TiWi5 Power-up Sequence Requirements**

1. No signals are allowed on the IO pins if no IO power is supplied, because the IOs are not 'failsafe'. Exceptions are CLK\_REQ\_OUT, SLOWCLK, XTALP, and AUD\_xxx, which are failsafe and can tolerate external voltages with no VDDS and DC2DC.
2. VBAT, VIO, and SLOWCLK must be available before WL\_EN.
3.  $T_{\text{wake-up}} = T_1 + T_2$

The duration of T<sub>1</sub> is defined as the time from WL\_EN=high until F<sub>ref</sub> is valid for the SoC. T<sub>1</sub> ≈ 55ms

The duration of T<sub>2</sub> depends on:

- Operating system
- Host enumeration for the SDIO/WSPI
- PLL configuration
- Firmware download
- Releasing the core from reset
- Firmware initialization

**WLAN POWER-DOWN SEQUENCE**

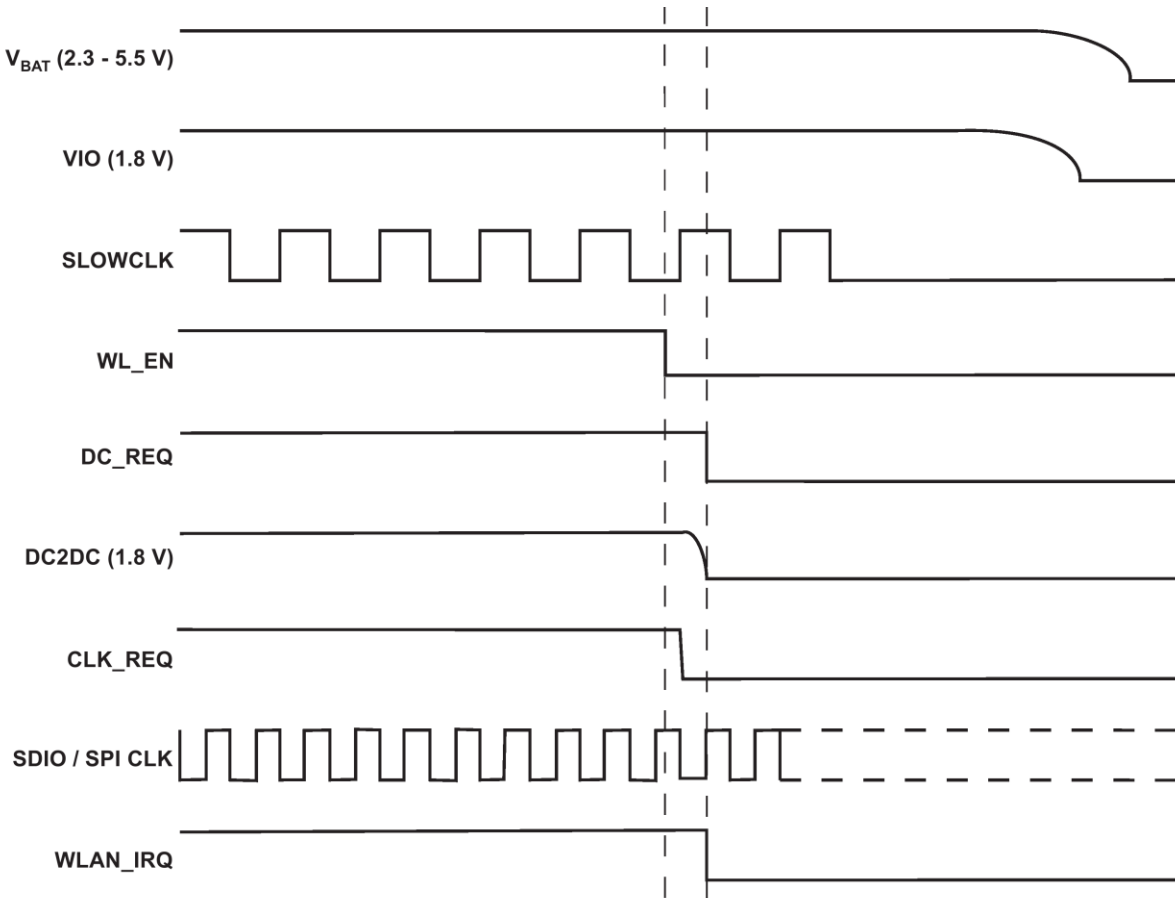

Notes:

1. The DC2DC(1.8V) signal can be monitored on BT\_FUNC2 Module Pin (#41)
2. DC\_REQ and CLK\_REQ are internal signals shown for reference only

**Figure 4 TiWi5 Module Power-down Sequence Requirements**

1. DC\_REQ will go low only if WLAN is the only core working. Otherwise if another core is working (e.g BT) it will stay high.
2. CLK\_REQ will go low only if WLAN is the only core working. Otherwise if another core is working and using the F<sub>REF</sub> (e.g BT) it will stay high.
3. If WLAN is the only core that is operating, WL\_EN must remain de-asserted for at least 64μsec before it is re-asserted.

**BLUETOOTH POWER-UP SEQUENCE**

The following sequence describes device power up from shutdown. Only the Bluetooth core is enabled; the WLAN core is disabled.

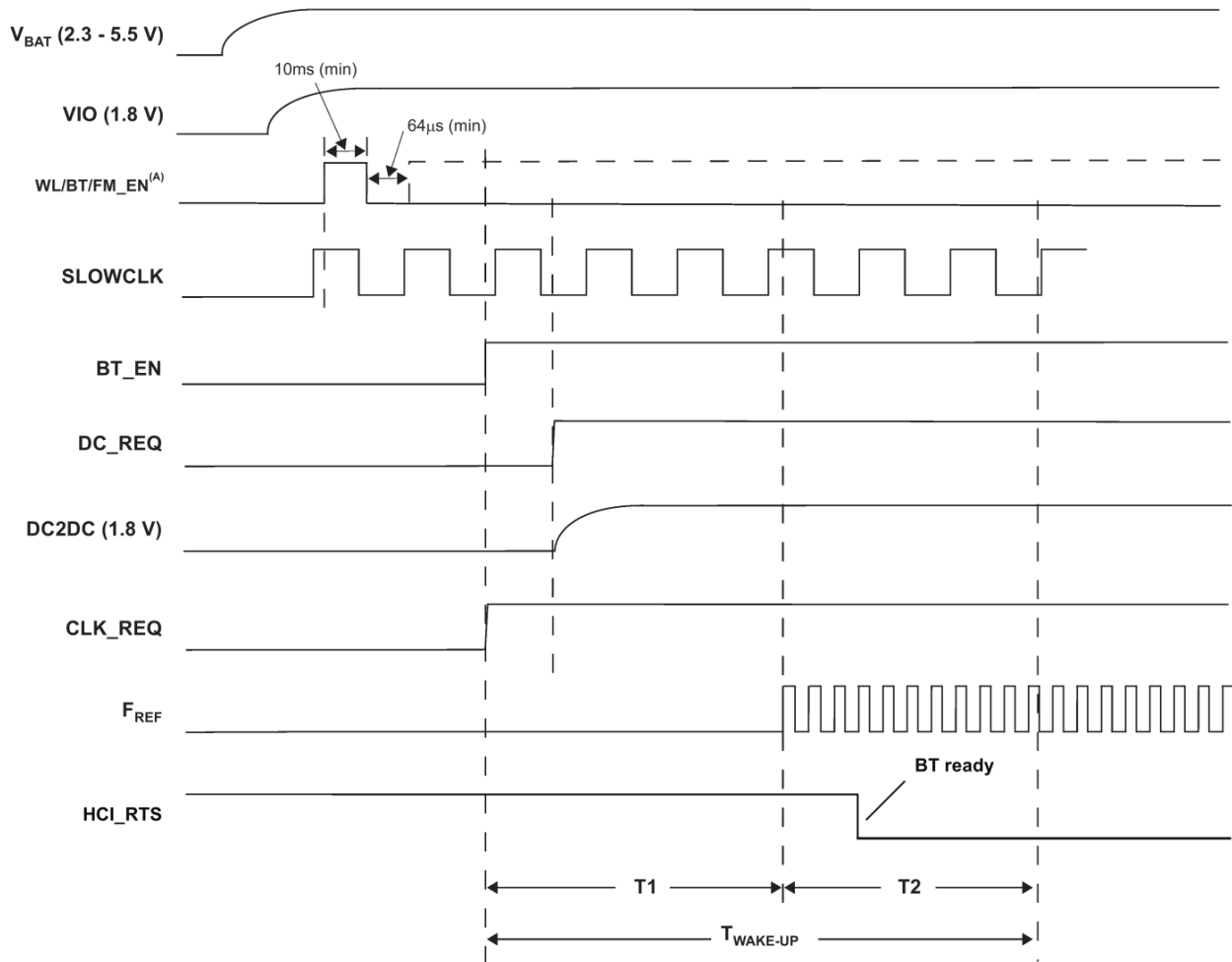

Notes:

1. (A) After this sequence is completed, the device is in the low VIO-leakage state while in shutdown
2. The DC2DC(1.8V) signal can be monitored on BT\_FUNC2 Module Pin (#41)
3. DC\_REQ, CLK\_REQ, and F<sub>REF</sub> are internal signals shown for reference only

**Figure 5 Bluetooth Power-up Sequence**

Power up requirements:

1. No signals are allowed on the IO pins if no IO power supplied, because the IOs are not 'failsafe'. Exceptions are CLK\_REQ\_OUT, SLOWCLK, XTALP, and AUD\_xxx, which are failsafe and can tolerate external voltages with no VDD5 and DC2DC.
2. VDD5 and SLOWCLK must be stable before releasing BT\_EN.
3. Fast clock must be stable maximum 55 ms after BT\_EN goes HIGH.

**BLUETOOTH POWER-DOWN SEQUENCE**

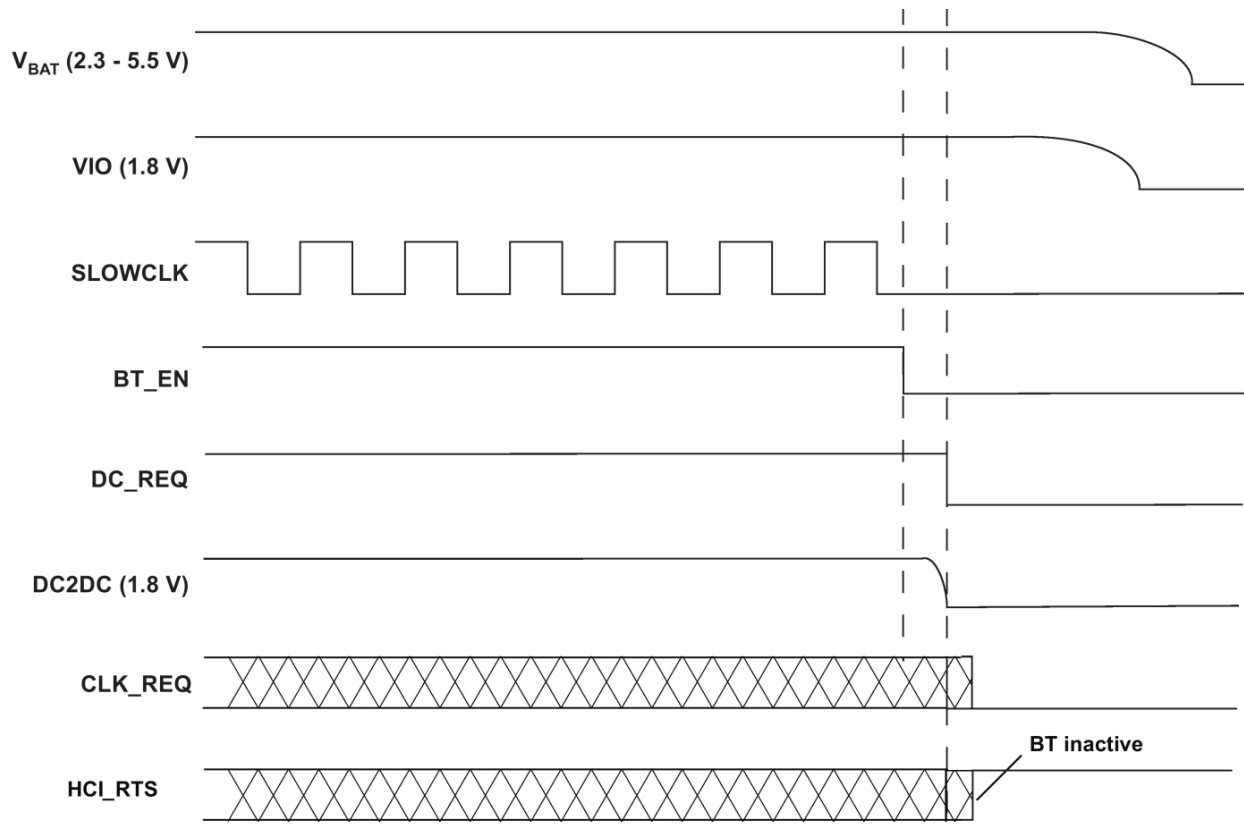

Notes:

1. The DC2DC(1.8V) signal can be monitored on BT\_FUNC2 Module Pin (#41)
2. DC\_REQ and CLK\_REQ are internal signals shown for reference only

**Figure 6 Bluetooth Power-down Sequence**

The TiWi5 module indicates completion of Bluetooth power-up sequence by asserting HCI\_RTS low. This occurs up to 100 ms after BT\_EN goes high.

## ENABLE SCHEME

The module has 3 enable pins, one for each core: WL\_EN, and BT\_EN and FM\_EN. Presently, there are 2 modes of active operation now supported: WLAN and Bluetooth. It is recommended that the FM\_EN pin be grounded to disable the FM section. It is also recommended that the FM section be disabled by Bluetooth HCI commands.

1. Each core is operated independently by asserting each EN signal to Logic '1'. In this mode it is possible to control each core asynchronously and independently.
2. Bluetooth mode operation. WLAN will be operated through WL\_EN asynchronously and independently of Bluetooth.

## IRQ OPERATION

1. The default state of the WLAN\_IRQ prior to firmware initialization is 0.
2. During firmware initialization, the WLAN\_IRQ is configured by the SDIO module; a WLAN\_IRQ changes its state to 1.
3. A WLAN firmware interrupt is handled as follows:
  - a. The WLAN firmware creates an Interrupt-to-Host, indicated by a 1-to-0 transition on the WLAN\_IRQ line (host must be configured as active-low or falling-edge detect).
  - b. After the host is available, depending on the interrupt priority and other host tasks, it masks the firmware interrupt. The WLAN\_IRQ line returns to 1 (0-to-1 transition on the WLAN\_IRQ line).
  - c. The host reads the internal register status to determine the interrupt sources - the register is cleared after the read.
  - d. The host processes in sequence all the interrupts read from this register
  - e. The host unmask the firmware interrupts.
4. The host is ready to receive another interrupt from the WLAN device.

## SLOW (32 KHZ) CLOCK SOURCE REQUIREMENTS

The slow clock is always supplied from an external source. It is input on the SLOW\_CLK pin, and can be a digital signal in the range of VIO only. For slow clock frequency and accuracy refer to Table 19. The external slow clock must be stable before the system exits from shut down mode.

Parameter [1]	Condition	Symbol	Min	Typ	Max	Unit
Input slow clock frequency				32768		Hz
Input slow clock accuracy	WLAN, BT				+/-250	ppm
Input transition time $T_r/T_f$ – 10% to 90%		$T_r/T_f$			100	ns
Frequency input duty cycle			30	50	70	%
Input voltage limits	Square wave, DC coupled	$V_{IH}$	$0.65 \times V_{DD5}$		$V_{DD5}$	$V_{peak}$
$V_{IL}$	0		$0.35 \times V_{DD5}$			
Input impedance			1			MW
Input capacitance					5	pF
Rise and fall time					100	ns
Phase noise	1 kHz			-125		dBc/Hz

[1] Slow clock is a fail safe input

**Table 19 Slow Clock Source Requirements**

**BLUETOOTH HCI UART**

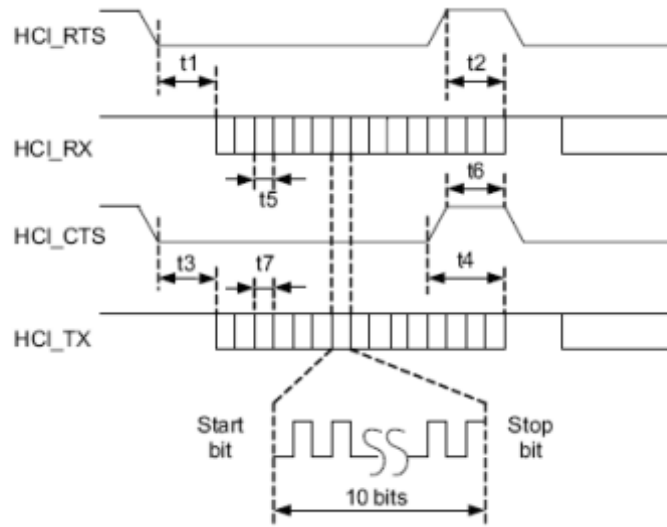

**Figure 7 Bluetooth UART Timing**

Symbol	Characteristics	Condition	Min	Typ	Max	Unit
	Baud rate	Most rates <sup>(1)</sup>	37.5		4000	kbps
t5, t7	Baud rate accuracy	Receive/Transmit			-2.5 to 1.5	%
t3	CTS low to TX_DATA on		0	2		μs
t4	CTS high to TX_DATA off	Hardware flow control			1	byte
t6	CTS-high pulse width		1			bit
t1	RTS low to RX_DATA on		0	2		μs
t2	RTS high to RX_DATA off	Interrupt set to 1/4 FIFO			16	byte
tb	Bit width (Jitter)		See application note <sup>(1)</sup>			% relative to ideal bit width

(1) Some exceptions: e.g. for 19.2-MHz max baud rate = 3.84 kbps.

**Table 20 Bluetooth UART Timing**



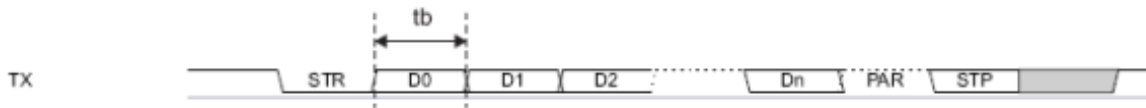

**Figure 8 Bluetooth UART Data Frame**

Symbol	Description
STR	Start bit
D0...Dn	Data bits (LSB first)
PAR	Parity bit (optional)
STP	Stop bit

**Table 21 Bluetooth UART Data Frame**

**SDIO INTERFACE TIMING**

PARAMETER		MIN	MAX	UNIT
$t_{CR}$	Delay time, assign relative address or data transfer mode	2	64	Clock cycles
$t_{CC}$	Delay time, CMD command valid to CMD command valid	58		Clock cycles
$t_{RC}$	Delay time, CMD response valid to CMD command valid	8		Clock cycles
$t_{AC}$	Access time, CMD command valid to SD3–SD0 read data valid	2		Clock cycles

**Table 22 SDIO Interface Read (see Figure 9)**

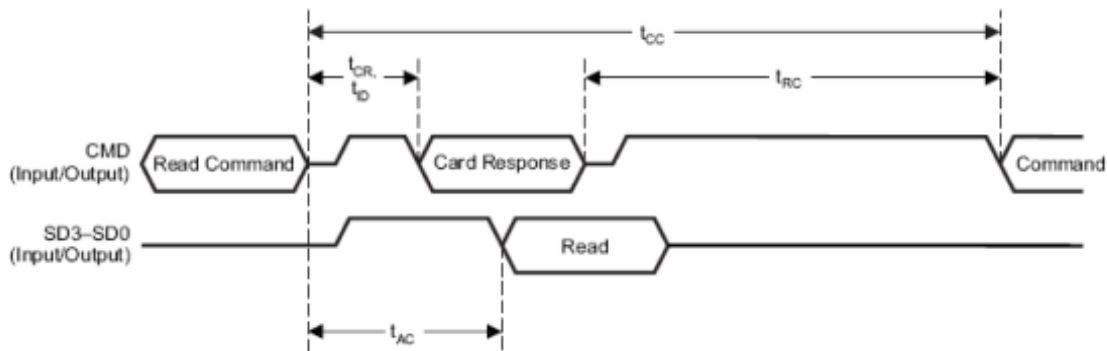

**Figure 9 SDIO Single Block Read**

PARAMETER		MIN	MAX	UNIT
$t_{d1}$	Delay time, CMD card response invalid to SD3–SD0 write data valid	2		Clock cycles
$t_{d2}$	Delay time, SD3–SD0 write data invalid end to CRC status valid	2	2	Clock cycles

**Table 23 SDIO Interface Write (see Figure 10)**

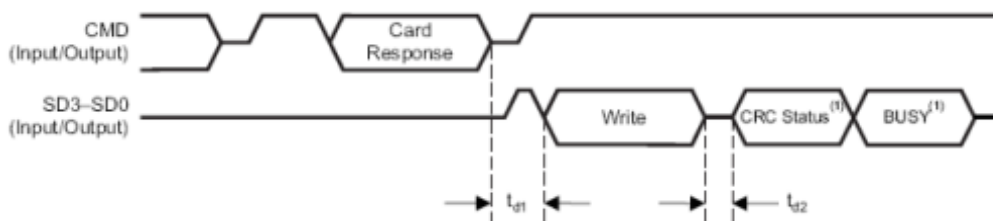

NOTE: CRC status and busy waveforms are only for data line 0. Data lines 1–3 are N/A. The busy waveform is optional, and may not be present.

**Figure 10 SDIO Single Block Write**

**SDIO CLOCK TIMING**

Over Recommended Operating Conditions

**Note:** all timing parameters are indicated for the maximum Host-interface clock frequency.

PARAMETER			MIN	MAX	UNIT
$f_{clock}$	Clock frequency, CLK	$C_L \leq 30$ pF	0	26	MHz
DC	Low/high duty cycle	$C_L \leq 30$ pF	40	60	%
$t_{TLH}$	Rise time, CLK	$C_L \leq 30$ pF		4.3	ns
$t_{THL}$	Fall time, CLK	$C_L \leq 30$ pF		3.5	ns
$t_{ISU}$	Setup time, input valid before CLK $\uparrow$	$C_L \leq 30$ pF	4		ns
$t_{IH}$	Hold time, input valid after CLK $\uparrow$	$C_L \leq 30$ pF	5		ns
$t_{ODLY}$	Delay time, CLK $\downarrow$ to output valid	$C_L \leq 30$ pF	2	12	ns

**Table 24 SDIO Timing**

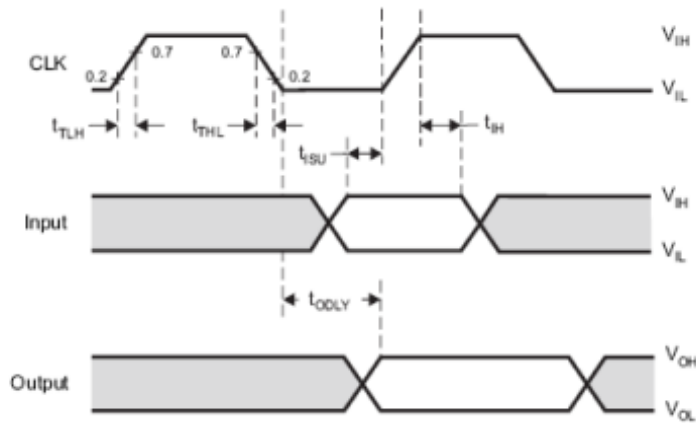

**Figure 11 SDIO Timing**

## SOLDERING RECOMMENDATIONS

### Recommended Reflow Profile for Lead Free Solder

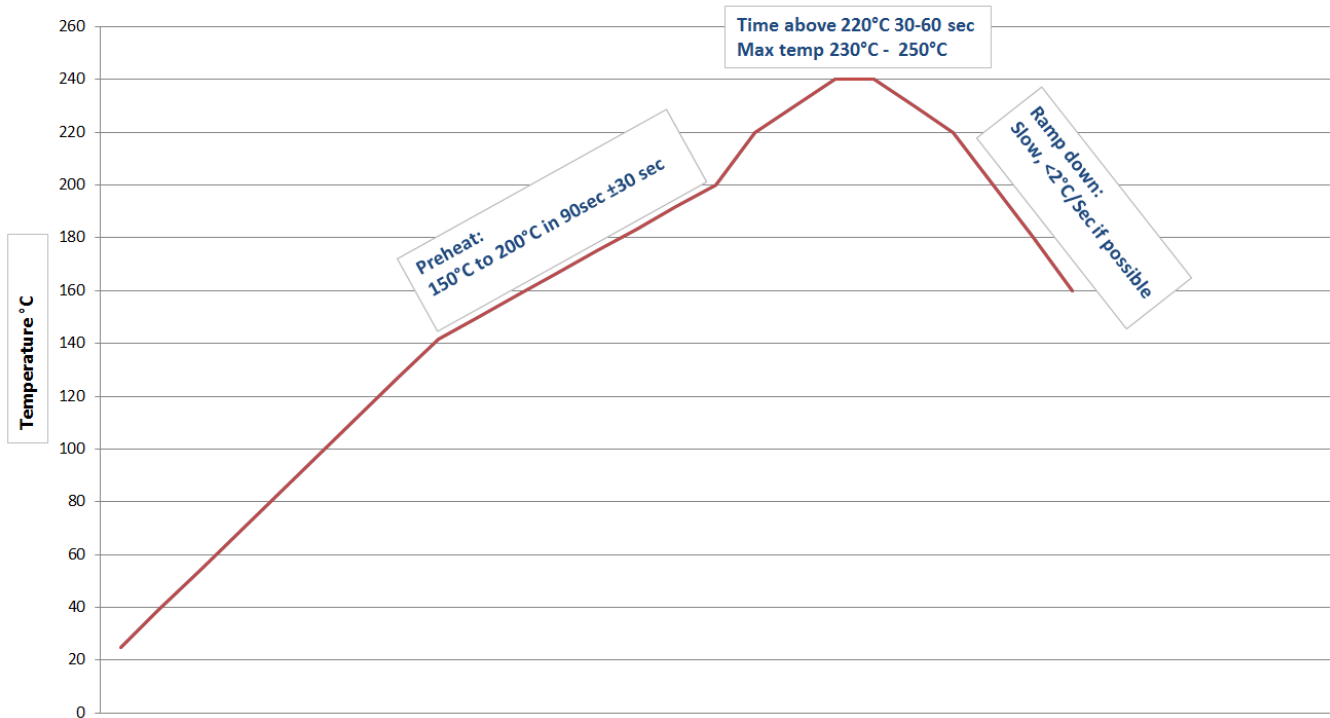

**Note: The quality of solder joints on the castellations ('half vias') where they contact the host board should meet the appropriate IPC Specification. See IPC-A-610-D Acceptability of Electronic Assemblies, section 8.2.4 Castellated Terminations."**

Figure 12 Reflow Profile

## CLEANING

In general, cleaning the populated modules is strongly discouraged. Residuals under the module cannot be easily removed with any cleaning process.

- Cleaning with water can lead to capillary effects where water is absorbed into the gap between the host board and the module. The combination of soldering flux residuals and encapsulated water could lead to short circuits between neighboring pads. Water could also damage any stickers or labels.
- Cleaning with alcohol or a similar organic solvent will likely flood soldering flux residuals into the RF shield, which is not accessible for post-washing inspection. The solvent could also damage any stickers or labels.
- Ultrasonic cleaning could damage the module permanently.

## OPTICAL INSPECTION

After soldering the Module to the host board, consider optical inspection to check the following:

- Proper alignment and centering of the module over the pads.
- Proper solder joints on all pads.
- Excessive solder or contacts to neighboring pads, or vias.

## REWORK

The module can be unsoldered from the host board if the Moisture Sensitivity Level (MSL) requirements are met as described in this datasheet.

**Never attempt a rework on the module itself, e.g. replacing individual components. Such actions will terminate warranty coverage.**

## SHIPPING, HANDLING, AND STORAGE

### Shipping

Bulk orders of the TiWi5 modules are delivered in trays of 100 or reels of 1,000.

### Handling

The TiWi5 modules contain a highly sensitive electronic circuitry. Handling without proper ESD protection may destroy or damage the module permanently.

### Moisture Sensitivity Level (MSL)

Per J-STD-020, devices rated as MSL 4 and not stored in a sealed bag with desiccant pack should be baked prior to use.

After opening packaging, devices that will be subjected to reflow must be mounted within 72 hours of factory conditions (<30°C and 60% RH) or stored at <10% RH.

Bake devices for 48 hours at 125°C.

### Storage

Please use this product within 6 months after receipt. Any product used after 6 months of receipt needs to have solderability confirmed before use.

The product shall be stored without opening the packing under the ambient temperature from 5 to 35deg.C and humidity from 20 to 70%RH. (Packing materials, in particular, may be deformed at the temperatures above this range.)

Do not store in salty air or in an environment with a high concentration of corrosive gas, such as Cl<sub>2</sub>, H<sub>2</sub>S, NH<sub>3</sub>, SO<sub>2</sub>, or NO<sub>x</sub>.

Do not store in direct sunlight.

The product should not be subject to excessive mechanical shock.



### Repeating Reflow Soldering

Only a single reflow soldering process is encouraged for host boards.

## AGENCY CERTIFICATIONS

FCC ID: TFB-TIWI501, 15.247

IC ID: 5969A-TIWI501, RSS 210

CE: Compliant to standards EN 60950-1, EN 300 328, and EN 301 489

SAR: This wireless mobile and/or portable device has been shown to be compliant for localized specific absorption rate (SAR) for uncontrolled environment/general exposure limits specified in ANSI/IEEE Std. C95.1-1999 and had been tested in accordance with the measurement procedures specified in IEEE 1528-2003, OET Bulletin 65 Supp. C, RSS-102 and Safety Code 6.

## AGENCY STATEMENTS

### Federal Communication Commission Interference Statement

This equipment has been tested and found to comply with the limits for a Class B digital device, pursuant to Part 15 of the FCC Rules. These limits are designed to provide reasonable protection against harmful interference in a residential installation. This equipment generates uses and can radiate radio frequency energy and, if not installed and used in accordance with the instructions, may cause harmful interference to radio communications. However, there is no guarantee that interference will not occur in a particular installation. If this equipment does cause harmful interference to radio or television reception, which can be determined by turning the equipment off and on, the user is encouraged to try to correct the interference by one of the following measures:

- Reorient or relocate the receiving antenna.
- Increase the separation between the equipment and receiver.
- Connect the equipment into an outlet on a circuit different from that to which the receiver is connected.
- Consult the dealer or an experienced radio/TV technician for help.

This device complies with Part 15 of the FCC Rules. Operation is subject to the following two conditions: (1) This device may not cause harmful interference, and (2) this device must accept any interference received, including interference that may cause undesired operation.

UNII devices operating within 5.15-5.25 GHz are to be restricted to indoor operations to reduce any potential for harmful interference to co-channel MSS operations.

**FCC CAUTION: Any changes or modifications not expressly approved by the party responsible for compliance could void the user's authority to operate this equipment.**

## Industry Canada Statements

Operation is subject to the following two conditions: (1) this device may not cause interference, and (2) this device must accept any interference, including interference that may cause undesired operation of the device.

To reduce potential radio interference to other users, the antenna type and its gain should be so chosen that the equivalent isotropically radiated power (e.i.r.p.) is not more than that permitted for successful communication.

This device has been designed to operate with the antenna(s) listed below, and having a maximum gain of 4.3 dBi (LSR Dipole) and 1.0dBi (Johanson Chip). Antennas not included in this list or having a gain greater than 4.3 dBi and 1.0dBi are strictly prohibited for use with this device. The required antenna impedance is 50 ohms.

List of all Antennas Acceptable for use with the Transmitter

- 1) LS Research 001-0009 dipole antenna and LS Research 080-0001 U.FL to Reverse Polarity SMA cable.
- 2) Johanson 2450AD46A5400E chip antenna.

UNII devices operating within 5.15-5.25 GHz are to be restricted to indoor operations to reduce any potential for harmful interference to co-channel MSS operations.

L'opération est soumise aux deux conditions suivantes: (1) cet appareil ne peut pas provoquer d'interférences et (2) cet appareil doit accepter toute interférence, y compris les interférences qui peuvent causer un mauvais fonctionnement de l'appareil.

Pour réduire le risque d'interférence aux autres utilisateurs, le type d'antenne et son gain doivent être choisis de manière que la puissance isotrope rayonnée équivalente (PIRE) ne dépasse pas celle permise pour une communication réussie.

Cet appareil a été conçu pour fonctionner avec l'antenne (s) ci-dessous, et ayant un gain maximum de 4,3 dBi (LSR dipôle) et 1.0dBi (Chip Johanson). Antennes pas inclus dans cette liste ou d'avoir un gain supérieur à 4,3 dBi et 1.0dBi sont strictement interdites pour l'utilisation avec cet appareil. L'impédance d'antenne requise est de 50 ohms.

Liste de toutes les antennes acceptables pour une utilisation avec l'émetteur

- 1) LS Research 001-0009 antenne dipôle et LS Research 080-0001 U. FL à Reverse SMA à polarité du câble.
- 2) Antenne Johanson puce 2450AD46A5400E.

Dispositifs UNII opérant dans 5.15-5.25 GHz doivent être limités à des opérations à l'intérieur afin de réduire tout risque d'interférences nuisibles à la co-canal exploitation du MSS.



## **OEM RESPONSIBILITIES TO COMPLY WITH FCC AND INDUSTRY CANADA REGULATIONS**

The TiWi5 Module has been certified for integration into products only by OEM integrators under the following conditions:

This device is granted for use in Mobile only configurations in which the antennas used for this transmitter must be installed to provide a separation distance of at least 20cm from all person and not be co-located with any other transmitters except in accordance with FCC and Industry Canada multi-transmitter product procedures.

As long as the two conditions above are met, further transmitter testing will not be required. However, the OEM integrator is still responsible for testing their end-product for any additional compliance requirements required with this module installed (for example, digital device emissions, PC peripheral requirements, etc.).

**IMPORTANT NOTE: In the event that these conditions cannot be met (for certain configurations or co-location with another transmitter), then the FCC and Industry Canada authorizations are no longer considered valid and the FCC ID and IC Certification Number cannot be used on the final product. In these circumstances, the OEM integrator will be responsible for re-evaluating the end product (including the transmitter) and obtaining a separate FCC and Industry Canada authorization.**

Le module de TiWi5 a été certifié pour l'intégration dans des produits uniquement par des intégrateurs OEM dans les conditions suivantes:

Ce dispositif est accordé pour une utilisation dans des configurations mobiles seul dans lequel les antennes utilisées pour cet émetteur doit être installé pour fournir une distance de séparation d'au moins 20cm de toute personne et ne pas être colocalisés avec les autres émetteurs, sauf en conformité avec la FCC et de l'Industrie Canada, multi-émetteur procédures produit.

Tant que les deux conditions précitées sont réunies, les tests de transmetteurs supplémentaires ne seront pas tenus. Toutefois, l'intégrateur OEM est toujours responsable de tester leur produit final pour toutes les exigences de conformité supplémentaires requis avec ce module installé (par exemple, les émissions appareil numérique, les exigences de périphériques PC, etc.)

**NOTE IMPORTANTE: Dans le cas où ces conditions ne peuvent être satisfaites (pour certaines configurations ou de co-implantation avec un autre émetteur), puis la FCC et Industrie autorisations Canada ne sont plus considérés comme valides et l'ID de la FCC et IC numéro de certification ne peut pas être utilisé sur la produit final. Dans ces circonstances, l'intégrateur OEM sera chargé de réévaluer le produit final (y compris l'émetteur) et l'obtention d'un distincte de la FCC et Industrie Canada l'autorisation.**

## **OEM LABELING REQUIREMENTS FOR END-PRODUCT**

The TiWi5 module is labeled with its own FCC ID and IC Certification Number. The FCC ID and IC certification numbers are not visible when the module is installed inside another device, as such the end device into which the module is installed must display a label referring to the enclosed module. The final end product must be labeled in a visible area with the following:

**“Contains Transmitter Module FCC ID: TFB-TIWI501”**

**“Contains Transmitter Module IC: 5969A-TIWI501”**

or

**“Contains FCC ID: TFB-TIWI501”**

**“Contains IC: 5969A-TIWI501”**

The OEM of the TiWi5 Module must only use the approved antenna(s) listed above, which have been certified with this module.

Le module de TiWi5 est étiqueté avec son propre ID de la FCC et IC numéro de certification. L'ID de la FCC et IC numéros de certification ne sont pas visibles lorsque le module est installé à l'intérieur d'un autre appareil, comme par exemple le terminal dans lequel le module est installé doit afficher une étiquette faisant référence au module ci-joint. Le produit final doit être étiqueté dans un endroit visible par le suivant:

**“Contient Module émetteur FCC ID: TFB-TIWI501”**

**“Contient Module émetteur IC: 5969A-TIWI501”**

ou

**“Contient FCC ID: TFB-TIWI501”**

**“Contient IC: 5969A-TIWI501”**

Les OEM du module TiWi5 ne doit utiliser l'antenne approuvée (s) ci-dessus, qui ont été certifiés avec ce module.



## **OEM END PRODUCT USER MANUAL STATEMENTS**

The OEM integrator should not to provide information to the end user regarding how to install or remove this RF module or change RF related parameters in the user manual of the end product.

**The user manual for the end product must include the following information in a prominent location:**

This device is granted for use in Mobile only configurations in which the antennas used for this transmitter must be installed to provide a separation distance of at least 20cm from all person and not be co-located with any other transmitters except in accordance with FCC and Industry Canada multi-transmitter product procedures.

Other user manual statements may apply.

L'intégrateur OEM ne devraient pas fournir des informations à l'utilisateur final sur la façon d'installer ou de supprimer ce module RF ou modifier les paramètres liés RF dans le manuel utilisateur du produit final.

**Le manuel d'utilisation pour le produit final doit comporter les informations suivantes dans un endroit bien en vue:**

Ce dispositif est accordé pour une utilisation dans des configurations mobiles seule dans laquelle les antennes utilisées pour cet émetteur doit être installé pour fournir une distance de séparation d'au moins 20cm de toute personne et ne pas être co-localisés avec les autres émetteurs, sauf en conformité avec FCC et Industrie Canada, multi-émetteur procédures produit.

Autres déclarations manuel de l'utilisateur peuvent s'appliquer.

## **EUROPE**

### **CE Notice**

This device has been tested and certified for use in the European Union. See the Declaration of Conformity (DOC) for specifics.

If this device is used in a product, the OEM has responsibility to verify compliance of the final product to the EU standards. A Declaration of Conformity must be issued and kept on file as described in the Radio and Telecommunications Terminal Equipment (R&TTE) Directive.

The 'CE' mark must be placed on the OEM product per the labeling requirements of the Directive.

### **Declaration of Conformity (DOC)**

This DOC can be downloaded from the LSR Wiki.

**MECHANICAL DATA**

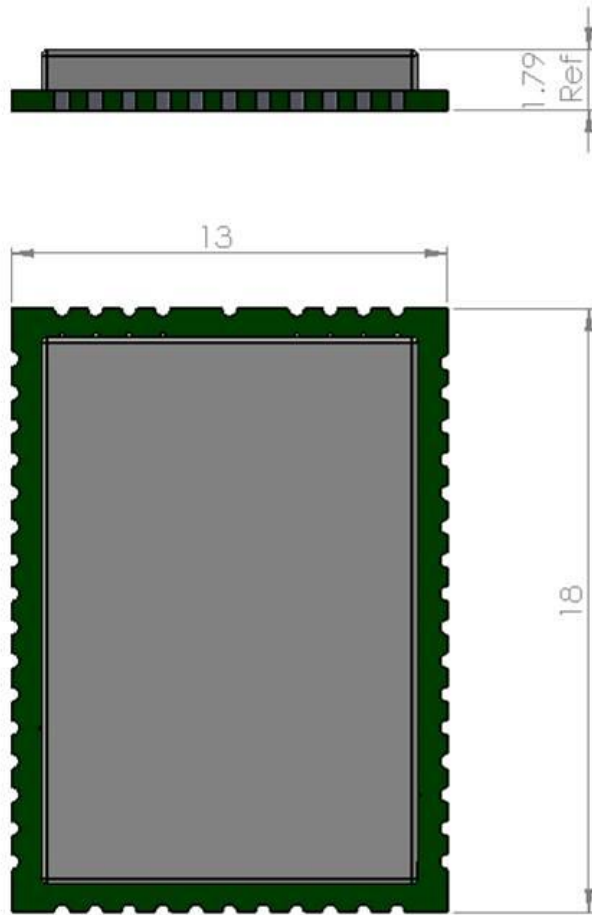

**Figure 13 Module Mechanical Dimensions (Maximum Module Height = 1.9mm)**

**PCB FOOTPRINT**

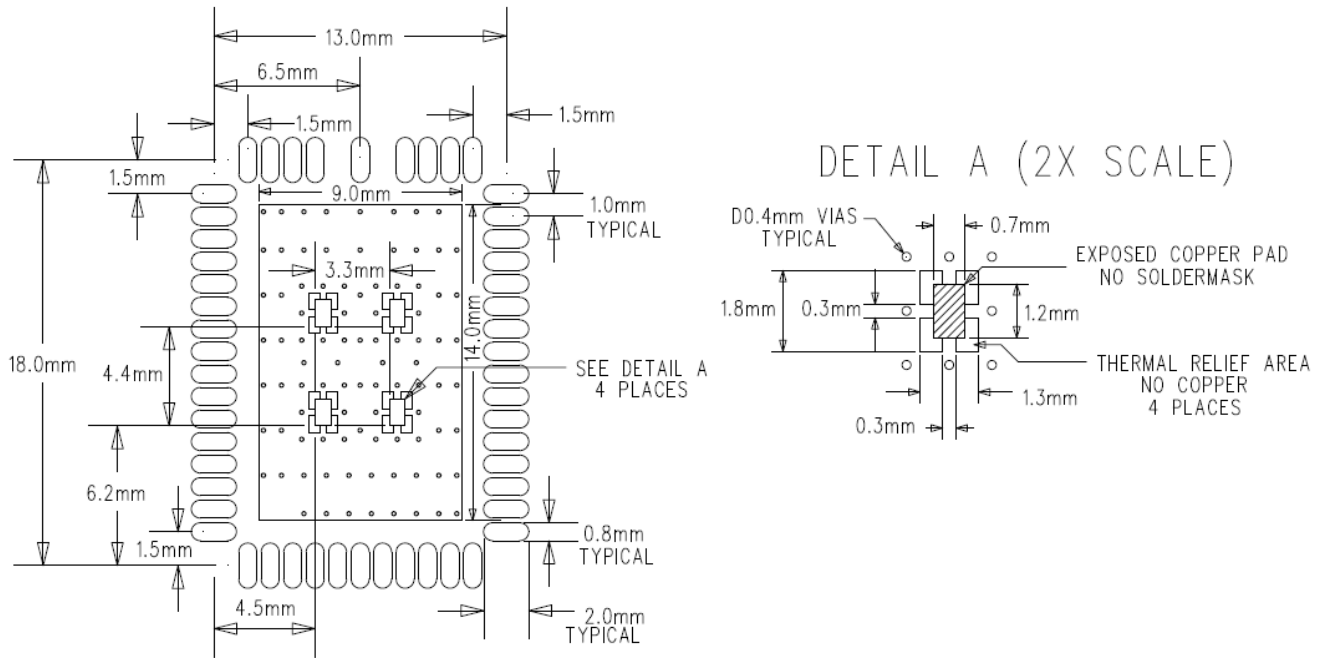

LAYOUT NOTES:

- 1 - MINIMUM 4-LAYER PCB WITH SECOND LAYER GROUND PLANE
- 2 - FOUR GROUND PADS BENEATH MODULE TO BE THERMALLY TIED TO TOP LAYER GROUND POUR (SEE DETAIL A).  
CONNECT TOP SIDE POUR TO LAYER 2 GROUND PLANE USING AMPLE VIAS.
- 3 - AVOID LONG ROUTES ON TOP LAYER BENEATH MODULE. VIA FANOUT BENEATH MODULE IS ACCEPTABLE,

**Figure 14 TiWi5 Recommended PCB Footprint (Top View)**



**TAPE AND REEL SPECIFICATION**

REVISIONS			
REV	DESCRIPTION	DATE	APPROVED

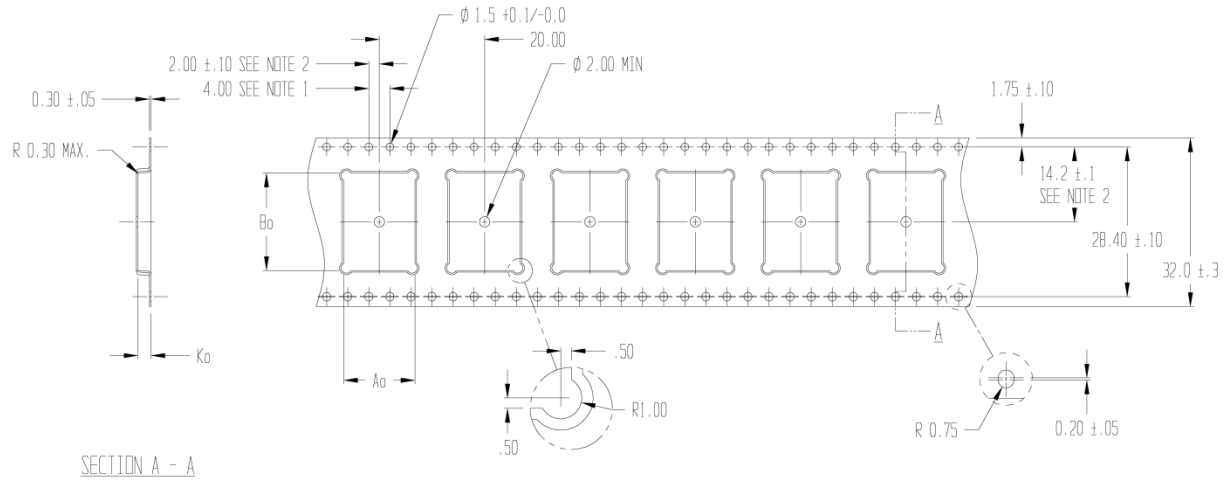

$A_0 = 13.50$   
 $B_0 = 18.50$   
 $K_0 = 2.50$

NOTES:

1. 10 SPROCKET HOLE PITCH CUMULATIVE TOLERANCE  $\pm 0.2$
2. POCKET POSITION RELATIVE TO SPROCKET HOLE MEASURED AS TRUE POSITION OF POCKET, NOT POCKET HOLE
3.  $A_0$  AND  $B_0$  ARE CALCULATED ON A PLANE AT A DISTANCE "R" ABOVE THE BOTTOM OF THE POCKET.

**Figure 15 TiWi5 Tape and Reel Specification**

## DEVICE MARKINGS

### Rev 1 Devices

WL1273L: WL1273LYFVR PG3.32  
Front End: TQP6M9002

- Pre-production devices.

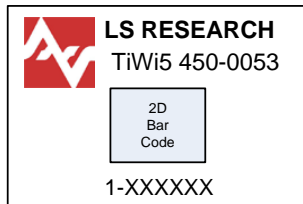

Where 1 = Revision  
XXXXXX = incremental serial number  
2D Barcode Format is Data Matrix Standard

### Rev 2 Devices

WL1273L: WL1273LYFVR PG3.32  
Front End: TQP6M9002

- LSR logo changed from red to black.
- Added FCC and IC numbers to the label.
- Revision number is no longer part of the serial number.
- Minor label format changes.

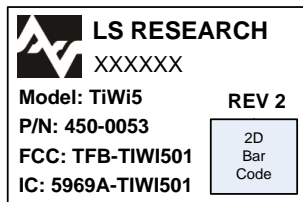

Where 2 = Revision  
XXXXXX = incremental serial number  
2D Barcode Format is Data Matrix Standard



**Rev 3 Devices**

WL1273L: WL1273LYFVR PG3.32  
Front End: TQP6M9002

- Incorporated PCB DFM improvements.

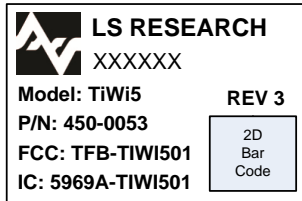

Where 3 = Revision  
XXXXXX = incremental serial number  
2D Barcode Format is Data Matrix Standard



## CONTACTING LS RESEARCH

<b>Headquarters</b>	LS Research, LLC W66 N220 Commerce Court Cedarburg, WI 53012-2636 USA Tel: (262) 375-4400 Fax: (262) 375-4248
<b>Website</b>	<a href="http://www.lsr.com">www.lsr.com</a>
<b>Wiki</b>	<a href="http://wiki.lsr.com">wiki.lsr.com</a>
<b>Technical Support</b>	<a href="http://forum.lsr.com">forum.lsr.com</a>
<b>Sales Contact</b>	<a href="mailto:sales@lsr.com">sales@lsr.com</a>

The information in this document is provided in connection with LS Research (hereafter referred to as “LSR”) products. No license, express or implied, by estoppel or otherwise, to any intellectual property right is granted by this document or in connection with the sale of LSR products. EXCEPT AS SET FORTH IN LSR’S TERMS AND CONDITIONS OF SALE LOCATED ON LSR’S WEB SITE, LSR ASSUMES NO LIABILITY WHATSOEVER AND DISCLAIMS ANY EXPRESS, IMPLIED OR STATUTORY WARRANTY RELATING TO ITS PRODUCTS INCLUDING, BUT NOT LIMITED TO, THE IMPLIED WARRANTY OF MERCHANTABILITY, FITNESS FOR A PARTICULAR PURPOSE, OR NON-INFRINGEMENT. IN NO EVENT SHALL LSR BE LIABLE FOR ANY DIRECT, INDIRECT, CONSEQUENTIAL, PUNITIVE, SPECIAL OR INCIDENTAL DAMAGES (INCLUDING, WITHOUT LIMITATION, DAMAGES FOR LOSS OF PROFITS, BUSINESS INTERRUPTION, OR LOSS OF INFORMATION) ARISING OUT OF THE USE OR INABILITY TO USE THIS DOCUMENT, EVEN IF LSR HAS BEEN ADVISED OF THE POSSIBILITY OF SUCH DAMAGES. LSR makes no representations or warranties with respect to the accuracy or completeness of the contents of this document and reserves the right to make changes to specifications and product descriptions at any time without notice. LSR does not make any commitment to update the information contained herein. Unless specifically provided otherwise, LSR products are not suitable for, and shall not be used in, automotive applications. LSR’s products are not intended, authorized, or warranted for use as components in applications intended to support or sustain life.

---

The information in this document is subject to change without notice.