



Excellence in Compliance Testing

Certification Exhibit

FCC ID: R7PEC1R1S1

FCC Rule Part: 15.247

ACS Project Number: 12-0278

Manufacturer: Landis+Gyr Technology Inc.
Model: Elster Multi-Function Meter Module

Manual

Draft 8/23/2013



Elster Multi-Function Meter Module Quick Start Guide

Publication: 98-1289 Rev AA



**Landis
|Gyr⁺**

LANDIS+GYR CONFIDENTIAL INFORMATION

Draft 8/23/2013

Limitation on Warranties and Liability

Information in this document is subject to change without notice. This manual or any part of it thereof may not be reproduced in any form unless permitted by contract or by written permission of Landis+Gyr.

In no event will Landis+Gyr be liable for any incidental, indirect, special, or consequential damages (including lost profits) arising out of or relating to this publication or the information contained in it, even if Landis+Gyr has been advised, knew, or should have known of the possibility of such damages.

Other brands or product names used are the trademarks or registered trademarks of their respective holders.

© 2013 Landis+Gyr, Inc. All Rights Reserved

Elster Multi-Function Meter Module Quick Start Guide			
Publication: 98-1289			
Revision History			
Modification Date	Revision	Description	Author
12/4/2012	AA	In Progress	Vicky Costello
Landis+Gyr 30000 Mill Creek Avenue, Suite 100 Alpharetta, GA 30022 Website: www.landisgyr.com E-mail: solutionsupport.na@landisgyr.com Technical Support: 1-888-390-5733	Copyright© 2013 Landis+Gyr All rights reserved.		

Overview

The Elster Multi-Function Meter Module (MFMM) is designed to provide active energy (Kilo-Watt hour) and reactive energy (Kilo-Var hour) data from Elster Alpha+ (A2) meters for use in residential and industrial commercial services.



Figure 1 - 1. Elster Multi-Function Meter Module

The meter kit includes:

- Elster Multi-Function Meter Module
- Elster Alpha+ (A2) Meter

- Antenna

Required Software

To work with the endpoint, you need at least one of the following software tools and documentation:

- UtiliNet Solution Center (USC)
- Meter Master Lite software
 - *Meter Master Lite Quick Start Guide*, publication number 98-0071
- Elster ALPHA Plus software

Landis+Gyr recommends you have RF Verify software and the *RF Verify User Guide*, publication number 98-0069.

Labels

The endpoint contains the following labels:



Figure 2. Label Identification

Table 1. Elster Label Identification

Label	Description
1	Elster Meter Name Plate
	AEP compliant bar code that defines meter manufacturer, form, base, test voltage and current, watt-hour constant, serial number, and customer specific information.
	Manufacturer or customer specified serial number
	Manufacturer model and style number

Table 1. Elster Label Identification

	Label	Description
2	Landis+Gyr FCC ID	Federal Communications Commission (FCC) Identification (ID) number assigned to the Elster Multi-Function Meter Module for use in the Elster Alpha+ meter.
3	Landis+Gyr LAN ID	Identifies the Elster Multi-Function Meter Module to the Landis+Gyr billing network (printed and barcoded).

LAN ID

The LAN ID is a unique identifier for each Landis+Gyr endpoint. Landis+Gyr provides the LAN address. You cannot change the radio's LAN IDs.

Features and Functions

Endpoint Registration

The endpoint is automatically registered with the host system. No special tools are needed during installation.

Admin packets are sent once each hour at a random time during the hour and play a crucial role in the automatic discovery of a meter by the Landis+Gyr system. They tell what kind of meter the module interfaces with, and other characteristics, such as the scaling constant, number of dials, and the firmware version.

Admin packets include:

Table 2. Admin Packet Information

Meter ID	Identifies the customer
Protocol ID	Identifies the type of meter.
Scaling Constant	Tells how to convert meter readings into real units such as kWh
Number of dials	Also referred to as displayed digits.
Maximum Sensor Change Rate	Tells how much the meter reading can change in a certain period of time.
Firmware Version	Specifies the firmware revision number.
Current Cumulative Reading from the meter	

Communication and Retrieving Data

A microprocessor on the communications module (MFMM) reads energy data through the meter's serial interface and transmits the information to the head end system. Several different packet types are sent. The most frequently sent packet contains the current rotational count and historical interval data that is useful for load profiling and time-of-use metering. Another less frequently sent (Admin) packet contains the current cumulative rotation count, useful for basic automatic meter reading applications. An Admin packet is sent once hourly and contains the information listed in Table 2.

Power Outage/Restoration

The Multi-Function Meter Module gets Power Fail signal from meter. The communication module saves critical endpoint data to non-volatile memory, creates and sends a configurable number of power fail messages (typically 20) to the host system that include the LAN ID.

When power is restored, the communication module (MFMM) sends a Power Up message from Channel 1 and Channel 2, if available, to the host system. This message includes the following information:

- LAN ID
- Total count
- Last ten interval counts

Customer Service

Contact Landis+Gyr Customer Support at solutionsupport.na@landisgyr.com or call 888-390-5733 with any questions or problems for guidance through the troubleshooting process.

Compliance

FCC Class B

This device complies with Part 15 of the FCC rules. Operation is subject to the following two conditions:

- (1) This device may not cause harmful interference, and
- (2) This device must accept any interference received, including interference that may cause undesired operation.

This equipment has been tested and found to comply with the limits for a Class B digital device, pursuant to Part 15 of the FCC Rules. These limits are designed to provide reasonable protection against harmful interference in a residential installation. This equipment generates, uses, and can radiate radio frequency energy and, if not installed and used in accordance with the Instructions, may cause harmful interference to radio communications. However, there is no guarantee that interference will not occur in a particular installation. If this equipment does cause harmful interference to radio or television reception, which can be determined by turning the equipment off and on, the user is encouraged to try to correct the interference by one or more of the following measures:

- Reorient or relocate the antenna.
- Increase the separation between the equipment and receiver.
- Consult Landis+Gyr or an experienced radio technician for help.



WARNING: Changes or modifications to this device not expressly approved by Landis+Gyr could void the user's authority to operate the equipment.

RF Exposure

In accordance with FCC requirements of human exposure to radio frequency fields, the radiating element shall be installed such that a minimum separation distance of 20 centimeters will be maintained.

Host FCC Label Requirement

In the final installation, the following information must be visible:

“Contains FCC ID: R7PEC1R1S1

This device complies with Part 15 of the FCC rules. Operation is subject to the following two conditions:

- (1) This device may not cause harmful interference, and
- (2) This device must accept any interference received, including interference that may cause undesired operation.”

Product Specifications

Table 3. Elster Multi-Function Meter Module Specifications

Category	Specification	Value or Range	
Compatible Meters	Elster ALPHA Plus Supported Meter Forms NOTE: Contact Elster Electricity for additional forms.	Form	Class
		1S	200
		1S	320
		2S	200
		2S	320
		3S	20
		4S	20
		35S	20
		35A	20
		12S	200
		12S	320
		13S	200
		13S	320
		13A	100
		36S	20
		36A	20
		9S	20
		10S	20
10A	20		
16S	200		
16S	320		
16A	100		
Electrical	Voltage	13.5VDC \pm 1V, 50mA (limited duration from meter's power supply)	
	Input Current	50mA	
RF	Output Power	22-26.5 dBm	
	Transmit Frequency	917.58 MHz (Fixed)	

Table 3. Elster Multi-Function Meter Module Specifications

Category	Specification	Value or Range
Standards Compliance	FCC Title 47 CFR Part 15 Subpart B & C	Radiated and Conducted Emissions
	IEC 61000 4-2,3,4,5	Electromagnetic Compatibility
	ANSI C12.1-2011	Electricity Metering
	ANSI C12.20-2002	Electricity Meters Standard
	ANSI C37.90.1	Substation Standards - Fast Transient and Oscillatory Waveform
	ANSI/IPC-A-610-Class 2	Workmanship Standard for Electronic Assemblies
Environmental	General Environmental	Outdoor, rain-protected, sunlight-exposed
	Operating Temperature Range	-40 to +85 C (under meter glass)
	Humidity	10% to 95% relative humidity, non-condensing
Mechanical	Size (Meter & Module)	Refer to Elster Technical Manual, TM42-2182E for more details.
	Weight (Meter & Module)	Refer to Elster Technical Manual, TM42-2182E for more details.

Physical Dimensions

The ALPHA Plus meter fits all standard S-base services. Meters with an A-base are also available. Figure 1 - 1 illustrates the S-base meter type and dimensions.



NOTE: The dimensions are for reference purposes only and should not be used for construction.

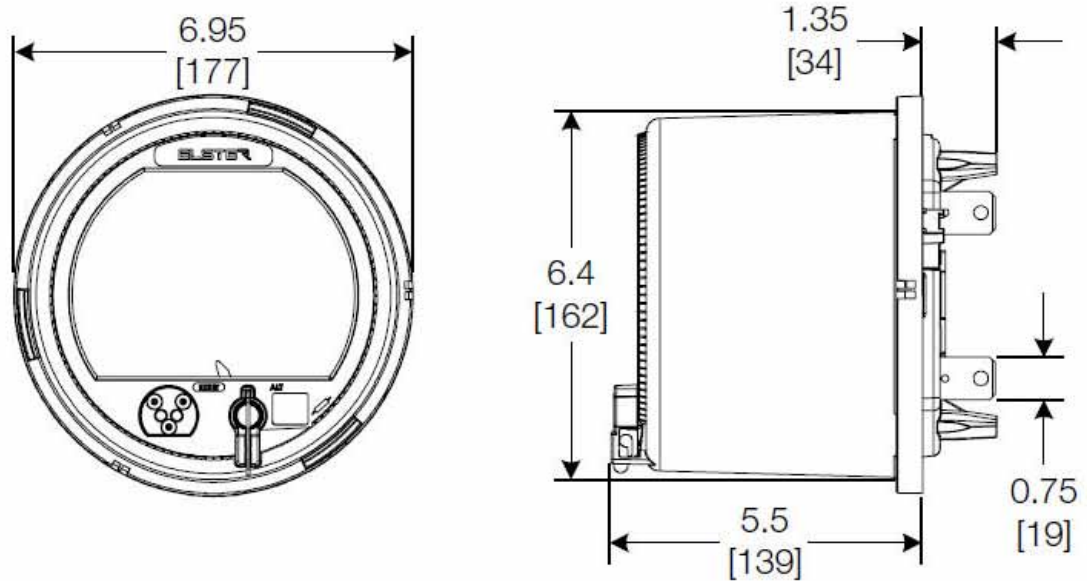

Figure 1 - 1. S-base Meter Type and Dimensions in Inches (millimeters) - Front and Side View
Figure 1 - 2 and Figure 1 - 3 illustrate the A-base meter type and dimensions.

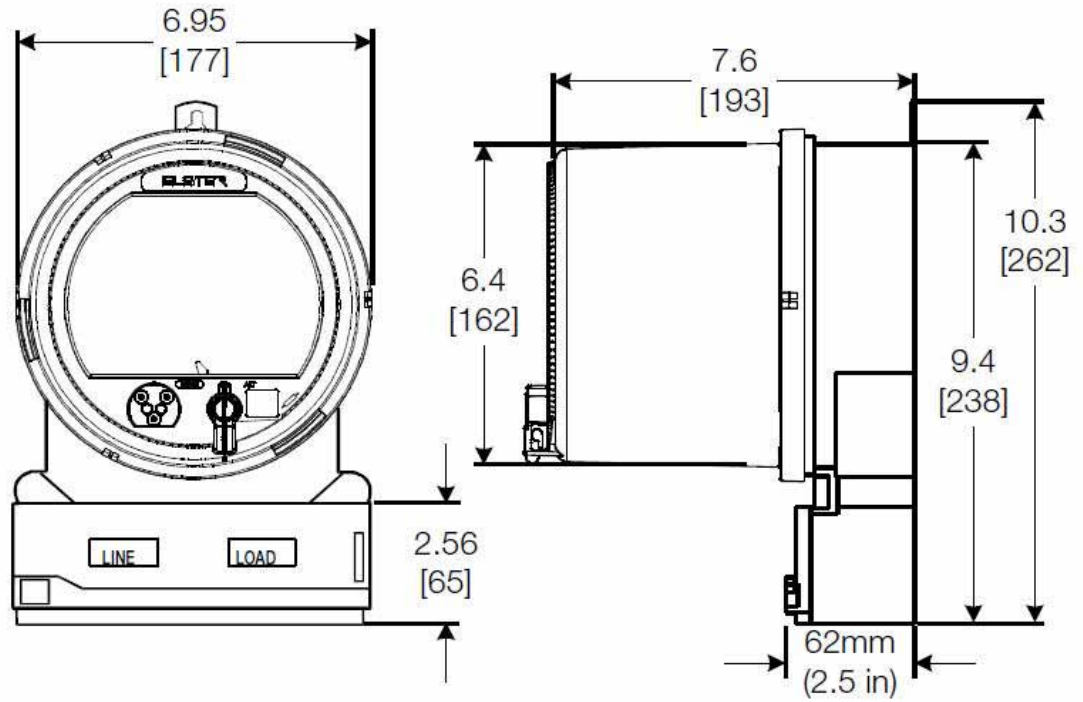

Figure 1 - 2. A-base Meter Type and Dimensions in Inches (millimeters) - Front and Side View

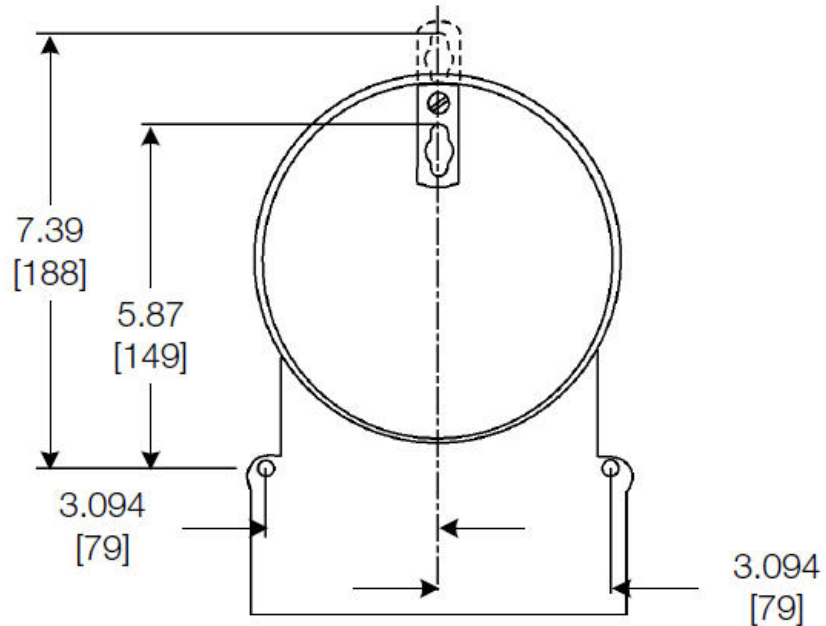

Figure 1 - 3. A-base Meter Type and Dimensions in Inches (millimeters) - Back View

Draft 8/23/2013