

PRELIMINARY

**TECHNICAL MANUAL
1 WATT VHF AMPLIFIER
FOR MX1V SERIES
TV TRANSMITTER/TRANSLATOR**

LARCAN INC.
228 AMBASSADOR DRIVE
MISSISSAUGA, ONTARIO
CANADA L5T 2J2

PHONE: (905) 564-9222
FAX: (905) 564-9244

VHF AMPLIFIER INSTALLATION

Contents:

Part	Topic	Page
1.	General Information	29-1
2.	Grounding and Ground Loops	29-2
3.	Lightning and other Transient Protection	29-4
4.	Power Wiring	29-9
5.	Ventilation and Air Conditioning	29-10
6.	Fire Protection	29-11
7.	Unpacking	29-12
8.	Transmitter External Interlock Connections	29-12
9.	On Site: First Time Startup	29-13

List of Figures:

Fig	Title	Drawing Reference
1	Transmitter Interlock Connections	text, pg 29-12
2	Application Diagram: Transmitter Grounding Principles	
3	Application Diagram: Tower and Building Grounding	

VHF AMPLIFIER INSTALLATION

Notes:

—

VHF AMPLIFIER INSTALLATION

IMPORTANT: If you haven't already done so, please take the time to read, study, and understand your Exciter manual, and all sections of this manual. You may find overlooked items that may be significant to your installation planning or to the actual work to be done.

1. GENERAL INFORMATION

The economics of manufacturing a transmitter dictates that much of the Installation information in its manual must be non-specific to any particular site. Although most of the following material, which we are presenting as "technical interest" information, is pertinent to higher powered transmitters, some of it is generally applicable to low powered equipment as well. We hope that one or more of these suggestions contained herein will prove helpful to you and provide worthwhile challenge to your imagination and technical ability.

One of the keys to a successful installation is meticulous planning and adequate allowances for task times. Allow sufficient time to consider and plan all aspects of the installation, including the building, whether new or existing, then allow for realistic time spans for the building construction or renovation, equipment transportation and installation, and final commissioning. A low powered transmitter naturally will require a very short time span for these activities, while high powered equipment could require many months. Should you feel apprehensive about planning an installation, simply phone or FAX our Applications Engineering Manager who is available and able to guide you. Your consulting engineer is also a good source of information. Both these persons would be familiar with technical aspects of the proposed installation.

Applications Engineering support offered by LARCAN includes technical information, recommendations on vendor products when requested, and advice on project task considerations and time span estimation. This assistance is available upon request; simply ask your LARCAN representative.

Although general application information (Figures 2 and 3) was included in this manual, it is important that specific system layouts be prepared, and that locations of cabinets and RF equipment such as RF patching or switching equipment, are determined together with the routing of the transmission line, AC power (Mains) feeds and other wiring, grounding (earthing), and ventilation air ducting. Lightning protection should be considered early in the planning process, because a good building layout can offer significant benefit.

We mention "cabinets" throughout this document, although the TTS10B and TTS50B transmitters were designed as single chassis for rack mounting in a standard 19" cabinet to be supplied by the customer. This assumption was based on the anticipated market for the transmitter being for standby or unattended isolated site locations, and that cabinet rack space of about 10½" would be available for mounting the amplifier and exciter or translator. The cabinet ventilation openings should be fitted with air filters, to help the transmitter components remain clean. Alternatively, a tabletop style of cabinet can be used instead if required.

Due consideration must be given to ventilation, as proper cooling ensures the longest equipment lifetime. Basic cooling information is provided in following Part 5, but if a higher powered transmitter is also on site, we believe that the importance of the subject may warrant and justify the hire of an experienced air conditioning contractor.

Ensure that sufficient space is available both in front and rear of all cabinets and other equipment to permit easy access while equipment is being moved around, and to enhance accessibility for future maintenance. A minimum 90 to 100 cm (about 3 to 3½ ft) of clearance is recommended to allow access for a technician and test equipment, but you may need more clearance for other reasons or for the lifting devices sometimes used during installations. You may wish to consult local equipment rental agencies for dimensions of their available lifting apparatus; the required clearance is one of the "planning" items to be considered.

All cabinets should be level. An uneven floor surface can distort the sheet metal frames of many cabinets so that door latches will not operate properly.

VHF AMPLIFIER INSTALLATION

2. GROUNDING/EARTHING

Please overlook our typically North American use of the word "grounding" throughout this text to describe a connection to earth, and the word "ground" which usually refers to a point of zero voltage, ie. the earth. We are certain, however, that the identical meanings of derivations of the word "ground" with those words pertinent to "earth" are universally understood by all broadcasters. That said, we shall proceed.

For safety, it is important that grounding conductors of adequate size be used to connect the transmitter (and other) cabinet(s) to the station "technical ground" point. The metal bulkhead plate through which all circuits and coax lines to and from the tower will pass, makes an excellent technical ground because it will be connected with one or two, 150 mm wide x 1.5 mm thick, copper straps to the tower ground system.

Figures 2 and 3 suggest one method, in which copper bar 75 or 100 mm wide and the same thickness as the floor tile is laid under transmitter and other cabinets for grounding. Each cabinet rack or tabletop cabinet is then connected with 1.5 mm copper strap or automotive starter cable to the copper ground bar. The copper bar in turn connects to the metal bulkhead plate. Alternatively, copper strap can be laid in a grounded overhead cable tray. Indoor grounding conductors must ultimately connect to the bulkhead plate.

Consult your electrical code book, or ask your electrical contractor about the minimum permissible ground conductor size, but for broadcast installations a low ground impedance is desirable, so generally the cross section of each cabinet ground should be the same or larger than the total of its AC wiring cross section.

All outdoor ground connections should be well bonded using an exothermic brazing process such as *Cadweld™* or equivalent. Special precautions should be taken to minimize corrosion where connections are made of dissimilar metals. Indoor connections can be brazed, silver soldered, or simply bolted together and then tin-lead soldered in the conventional manner. When indoors, don't forget that the steelwork, the ventilation system, and all other metallic objects in the building, should also be grounded.

It is mandatory that a good low impedance earth ground be provided for the tower, and it is good practice to employ this tower ground for all station ground connections. A system of buried radial conductors as shown in Figure 3, extending outwards from the tower base and from each guy anchor, with their far ends terminated in several ground rods spaced about twice their length apart and driven into the water table, is considered to be a good ground. The steel rebars and J-bolts in footings should also be bonded to this ground system. *Be careful of dissimilar metals, and don't braze anything to the tower legs!* Use stainless steel worm gear style hose clamps to clamp copper strap or copper wires to the tower members. A special conductive grease is available to avoid dissimilar metals corrosion, but frequent inspection is necessary.

More heroic measures become necessary if the tower footing is located on solid bare rock. These measures would include setting the grounding radials in poured concrete (which has surprisingly good conductivity), doping with conductivity-enhancing chemical salts such as magnesium sulphate (Epsom salts are supposed to be less environmentally harmful than others), and using special hollow ground rods that are intended to be driven into holes drilled in the rock, and which are said to bond chemically to the rock and provide excellent grounding, as long as they are kept filled with water or chemical solution. "ULTRA GROUND" rods are available through LARCAN or from our business affiliate LeBlanc & Royle Telcom Inc.

The building layout should place the tower, its wiring, transmission line, the AC panels and surge suppressor, and the telephone terminations, all near one another so that all ground connections are as short as possible; all indoor equipment should be grounded to the same "technical ground" which we suggest should be the bulkhead plate, which will become a good low impedance ground when connected with several 150 mm copper straps to the tower. This single technical ground will provide the basis for lightning protection of all equipment in the building. Both the power company and the telephone company should also use this same technical ground, otherwise a lightning hit to the tower could easily induce damaging transients that back up *through the equipment* and out the power or phone line to its own ground connections. Surge suppressors for coax lines and other tower circuits can mount (and ground) on the bulkhead plate.

VHF AMPLIFIER INSTALLATION

Many installations in large cities make use of existing tall buildings or specifically dedicated structures (such as the CN Tower in Toronto, Canada), and grounding for these installations could present a slight challenge.

Most tall structures are provided with wide copper straps running from top to base, and grounded at or under the building foundations. The structural steel is also grounded to the same point. The challenge occurs when the structure sustains a lightning hit, because an enormous voltage gradient will be present from top to bottom. Equipment grounding must be done *to one point only*, as explained in the next section.

Although most audio and video signals around the transmitter plant are of relatively high levels, it is well to be aware of another planning aspect that should be addressed anyway; this is the possibility of inadvertent creation of one or more "ground loops" of the kind that can induce hum into low level audio circuits.

The most common cause of the hum-inducing kind of "ground loop" is a result of code-approved electrical work in which all wiring is placed inside metallic conduit or raceway, and the conduit is attached to, and in contact with, the grounded structural steelwork of the building.

Here is what can happen: 1. The transmitter cabinets are grounded; 2. The electrical service panels are grounded; 3. The conduit or raceway additionally may be grounded through its fasteners to the structural steel; 4. The service panel is connected by the metallic path through a conduit or raceway to the transmitter cabinet. The result is one or more large area single turn loops that have AC induced in them due to the wiring in the conduit, but which can induce significant hum currents into low level audio wiring.

Suggested treatment for these AC ground loops, is simply to break each metallic loop by using a short length of non-metallic duct on the end of the metallic raceway, or use a short non-metallic section or a non-metallic coupling in the run of conduit. This non-metallic part should be located as near as possible to the cabinet. **IMPORTANT: Non-metallic parts used for electrical work must not be able to burn, nor emit hazardous gases when subjected to flames.** You will need to work out the exact ground loop treatment method with your electrical contractor, and probably with your local electrical inspector as well.

This grounding treatment is acceptable to most regulatory authorities in North America and perhaps elsewhere as well, *provided that the equipment in fact is grounded through the copper ground conductors, the bulkhead plate, and solid tower ground.* Note that this method does require installation of a separate dedicated grounding wire inside each conduit for the connection of the isolated ground contact of each receptacle, wherever receptacles are used. It is assumed that isolated ground receptacles are available, usually for use in computer rooms and in hospitals.

It may be necessary that you and your electrical contractor also become technical instructors, in order to reassure your electrical inspector that reduction of ground loops does not in fact contravene the applicable codes. At the very least you will probably need to prove that all your equipment is indeed grounded, despite the non-metallic connection of conduit or raceway.

Other, less severe, ground loops can result from the outer conductors of coax cables being grounded to the chassis of the equipment at both ends of the cable, and of course these components are also grounded through the cabinets in which they mount. LARCAN exciter video inputs use a differential connection and are not grounded, so do not contribute to a coaxial cable ground loop. The transmission line, however, is grounded at the tower, at the bulkhead, and at the transmitter.

Treatment of coax cable ground loops usually consists of coaxial cable dress in such a manner as to minimize the area presented by the loop. Lowering the line bridge between the building and tower will indeed reduce the loop area presented by the transmission line, but more importantly a lowered line bridge significantly reduces the energy induced on the center conductor due to a direct lightning hit to the tower. 100 to 130 cm (3-4 ft) above grade is the suggested maximum bridge height.

VHF AMPLIFIER INSTALLATION

2. GROUNDING/EARTHING (continued).

The Canadian Broadcasting Corporation, through its Engineering Headquarters group, maintains its own standards for equipment design and installation and has published many of these for the information of its suppliers. The CBC specification *Technical Power Distribution and Grounding Standards, ESS-124* and CBC drawing 45753 which indicates the grounding practices followed in its installations, are highly recommended. Upon request, LARCAN can provide you with a copy of these CBC documents.

Although we try to avoid touting any particular vendor or product, we have no hesitation in also recommending two publications from the PolyPhaser Corp, phone 1-800-325-7170 or (702)-782-2511, FAX (702)-782-4476. In Canada, their rep is SINCLABS INC, tel (905)-841-0624, FAX (905)-727-0861.

One is *The GROUNDS for Lightning and EMP Protection, Second Edition* by Roger R. Block; this text published by PolyPhaser is well worth the small price asked. *Lightning/EMP and Grounding Solutions* is the current PolyPhaser catalog of grounding materials and lightning surge suppression devices. The catalog is free. Both of these publications are recommended reading for anyone planning a ground system.

3. LIGHTNING AND OTHER TRANSIENT PROTECTION - a tutorial:

A large proportion of the following information which is offered about lightning, was taken from a booklet entitled *LIGHTNING PROTECTION for RADIO TRANSMITTER STATIONS* published in 1985 by NAUTEL, which is a Canadian manufacturer of AM transmitting equipment; other information came from the PolyPhaser catalog and from their textbook *The GROUNDS for Lightning & EMP Protection, Second Edition* which we recommend highly as worth its modest purchase price for anyone planning a ground system.

We would like to thank the people at both NAUTEL and PolyPhaser, and we hereby gratefully acknowledge their contributions to the state of the art:

The real-world environment of transmitting equipment is one where periodic lightning storms may occur and cause antenna, tower, and power line strikes. The actual incidence varies widely with geographic location and is also affected by local topography, the height of the tower, and routing of the incoming power and telephone lines. Unless precautionary steps are taken, such strikes could cause transmitter damage, particularly to the final amplifiers and to the AC line rectifiers associated with them.

Our major area of concern is with the lightning strike caused by discharge of energy from an electrically charged cloud to ground.

Most electrical storms are localized, short in extent, and caused by localized air heating and convection. A less common but more troublesome type of storm is the frontal type caused by the meeting of warm-moist and cold-dry air masses, extending up to several hundred miles. The weather office people in the U.S. and Canada, and elsewhere, publish maps called "isokeraunic charts" which indicate the mean annual number of days having thunderstorms; these are shown as contours which in North America will vary from $C = 1$ for northern Canada, all the way to $C = 100$ for central Florida. (In equatorial regions worldwide, C is even higher. In some parts of Africa, $C = 150$, and in South America in the Amazon basin, $C = 200$). The average number of lightning strikes per square mile per year may be deduced from these contours by multiplying the C number by 0.37. For localized convection thunderstorms, the strike incidence is about 75% of the frontal storm incidence, perhaps due to more frequent cloud-to-cloud discharge occurrences.

A grounded (antenna) structure of "H" feet height is considered by some authorities to essentially cover an area of $9\pi H^2$ square feet (a radius approximately three times its height), and strike incidence within that area at a site where frontal storms predominate, will be approximately $C \times 0.375 H^2 \times 10^6$.

VHF AMPLIFIER INSTALLATION

The foregoing leads us to speculate that a 500 foot tower in central Florida (or its equivalent in another region), in contour 100 and with frontal storms, will be struck an average of 9.4 times a year, and for the Canadian prairies in contour 20 with summertime convection storms, a 500 foot tower would receive an average of 1.4 hits per year. More important, the "lightning attractiveness" of the tower depends on the SQUARE of its height. If the tower is situated on top of a hill or mountain, "H" will be increased by the hill or mountain height, and becomes approximately equivalent to the antenna EHAAT. In practice, dimension "H" is slightly higher than the antenna elevation, because a metal lightning rod will be installed for protection of the topmost strobe or incandescent beacon, which is usually located above the antenna.

A lightning strike begins with a local ionization of the atmosphere called a "step leader" which jumps at a velocity about 150 ft per 1 μ s increment, every 49-50 μ s. It can be assumed that during each dormant 49 μ s interval, this leader builds up its voltage to cause ionization for the next 150 ft, and then finds its next step, within an imaginary hemisphere of 150 ft radius.

Since it is postulated to be within a hemisphere, the step leader geometry can be such that a *horizontal* strike to a tower can occur anywhere higher than the 150 ft point above average terrain, so side mounted panel or STL microwave antennas can be just as vulnerable as top mounted slot or turnstile designs. Fortunately, the STL antenna is often flanked by metallic guy wires, thus has somewhat better protection, but guys that happen to be located in front of the panels of the main antenna are usually fiberglass to avoid distortion of the radiation pattern.

Imagine a large ball 300 ft in diameter, rolling around in all directions; wherever it touches a grounded object, can become a point of attachment for a lightning hit. (From this, we can infer that coaxial "grounding kits" will be required at least at the 150 ft point on the tower, at frequent intervals above that, and most definitely at both the base of the tower and the bulkhead plate in the building wall).

The return (main) stroke of a lightning strike is characterized by a rapid rise and nearly exponential decay of current, essentially from a high impedance source comprised of a long length of ionized air. Presumably, the inductance of this air path determines the rate of rise of the current, and the air path resistance determines the current peak value and its decay rate.

Obviously the current peak value will vary from strike to strike, and statistical probability based on empirical data indicates a median value (50% of all lightning strikes) of 18,000 to 20,000 amperes, while the pulse decay length to half its peak amplitude also has a probability distribution range from 10 μ s to 100 μ s, with a median value of 40 μ s. There is also a 5% probability that the peak current can reach 80,000 amps, and a 1% probability that it can attain 120,000 amps. A once-in-a-lifetime monster peak current of 350,000 to 400,000 amperes is also statistically possible, maybe once every 10,000 hits. The current pulse median rise time to peak amplitude, is of the order of 5 μ s.

The lightning strike consists of a discharge from a charged cloud into the semi-infinite reservoir which is called "ground" or "earth". Unfortunately, at the surface of our planet an ideal terminal connecting to the ideal ground (earth) is rarely if ever available; practical terminals will connect to it via a finite impedance having both resistance and inductance, ranging from a few ohms to a few hundred ohms.

This implies that if an impedance of, say, 10 ohms to the ideal ground is what you have, then an average lightning hit of 20,000 amps will deliver 200 kV across the 10 ohms, and it is obvious that this must be prevented from reaching the equipment. Considering the magnitudes of the lightning strike currents, it is mandatory that the best possible earth ground system available should be used, as we stated in the previous section on Earthing and Grounding, above.

If the tower ground is connected via other wiring (eg. grounding radials, and the power and phone lines) to remote grounds, a substantial part of the strike current can flow to these remote grounds, therefore the real connection to ideal ground becomes a *parallel combination of all possible ground paths*.

VHF AMPLIFIER INSTALLATION

3. LIGHTNING AND OTHER TRANSIENT PROTECTION - a tutorial: (continued).

A single technical ground point for the equipment minimizes the bad effects of a lightning strike, because although the hit may raise this technical ground to 200 kV above the iron core of planet Earth, everything else on site connected to this same ground point is also raised equally to 200 kV, thus no damage is done. For installations in typical large city downtown locations, this is the only way of dealing with the enormous voltage gradients that can be developed over the height of a tall structure. When the transmitter is installed on the top floor of the tall building by itself and fed with microwave or other STL, there is no real problem.

When the studios and offices are located on a lower floor of the same building, and the standby plant is in a vault in the basement, during a lightning strike their technical grounds will be at a considerably lower voltage than that of the technical ground of the transmitter. In this situation you will need surge suppressors and plenty of isolating ferrite toroids to ensure the lightning goes down the ground strap and not down your signal and AC wiring. If coax video and twisted pair audio feeds seem less than desirable, you may wish to contemplate, evaluate, and use the complete isolation offered by fiber optics.

For discussion purposes, a median lightning strike can be considered to be a near-exponential **unidirectional** pulse of **20,000 amperes** peak amplitude, lasting **40 microseconds** to half-amplitude. For obvious reasons, it is impossible to exactly duplicate a lightning strike in the laboratory, so various working standards groups such as the IEEE in the electrical equipment industry have derived a repeatable, similar unidirectional pulse definition (ANSI C62.1) which implies that a "standard" fast power line transient (not necessarily lightning) has an 8 μ s rise time, and a half amplitude time of 20 μ s. This "8 x 20" definition appears frequently in MOV vendor information data sheets. There is also another common definition, based on a 10 μ s rise and a half amplitude time of 1000 μ s (10 x 1000), which is used by the MOV vendors as their standard to rate the energy dissipation of their devices.

The peak pulse current of 20,000 A can be used for estimating the size of surge suppressor required on the AC mains: Assume that the suppressor contains MOV devices that clamp the transient to less than 500 V above ground for a 115-0-115 V mains, therefore the energy dissipated will be the mathematical integral of a nearly exponential waveform which starts at time $t = 0$ and builds linearly to an instantaneous peak power of 10 Megawatts (20,000 amps x 500 volts) in the first 5 μ s, decreasing in 40 μ s exponentially to half amplitude, eventually decaying to zero. The answer is in Joules, which is the SI name for watts x seconds.

Vendors of MOV surge suppressor devices have published simplifying algorithms for this integral. They assume that a lightning hit has a two part waveform, and the answer is the sum of two equations of the form $K \times V \times I \times t$ where K is a constant corresponding to the evaluation of the integral of the part of the waveform being examined, V is the clamp voltage of the MOV, I is the peak current, and t is time in seconds. The first part of the wave has $K = 0.5$ so its energy is $0.5 \times 500 \times 20000 \times 5 \times 10^{-6} = 25$ J; while the second part $K = 1.4$ so its energy is $1.4 \times 500 \times 20000 \times 40 \times 10^{-6} = 560$ J. Adding the two, gives us 585 Joules. Multiple lightning current pulses during single hits are fairly common, so the energy number should be multiplied by another 5 or 6 when you decide on your surge suppressors.

For tall building installations, you may wish to multiply the energy number again, because the multiple ground paths available at grade level installations are not present here except for the building structural steel and copper strap ground, *and most probably the AC mains*. The mains therefore would carry a larger proportion of the strike current, and the suppressors should be appropriately chosen for higher peak current.

The entire basis of lightning protection is that the strike current should never be allowed to blast through the equipment, but paths should be provided for this current to go *around* it instead. These paths are provided through properly grounded (to your single technical ground) transient surge suppressors installed on all incoming wires, even if for aesthetic reasons they all arrive underground. These "incoming wires" include AC mains, other power circuits, and signal, telephone, and remote control circuits entering the building from the outside world, *and from the tower*.

VHF AMPLIFIER INSTALLATION

For any near or direct lightning hit, the tower wiring is "incoming" to the equipment in the building. You need the best possible ground at the tower to ensure that most of the current from the hit goes to ground at the tower, and much less goes to ground at the suppressors where the lines enter the building.

Series inductance should then be installed on the equipment side of each and every circuit (between the suppressor and the equipment) to provide enough isolating impedance that the transient is forced to choose the easier path through the suppressor, instead of through the equipment.

The minimum inductance needed can be calculated from the basic inductance expression $V = L di/dt$, where V = the suppressor clamping voltage, and di/dt = peak amps/risetime; when we rearrange this equation and plug in some numbers, $L = 500V \times 5\mu s/20,000A = 0.125 \mu H$. Two or three ferrite toroids have been empirically proven to provide adequate inductance for lightning isolation when placed over each circuit, and in practice they limit the current to much lower values than 20,000 amps. The inductance of a toroid can be measured, or calculated from the vendor's data sheets.

Suitable ferrite toroids are offered by TDK, Fair-Rite, Siemens, and Ferroxcube. Typical TDK part numbers are H5C2-T52-72-10, which is 2" ID, and H5C2-T74-90-13.5, which is 2p" ID. Equivalent ferrite toroids from other vendors could also be used if their sizes are adequate. TDK's H5C2 material has a high permeability μ_r of about 10,000, high saturation B_{sat} value of about 4000 gauss, and moderate Curie temperature of about 120°C. Other ferrites as used in switchmode power supply transformer applications should work as well, except that their μ values are usually much lower so more toroids would be required. The TDK toroids cited have AL values about 5000 to 6000 nH/N², suggesting about 5 to 6 μH each toroid.

Please note that we specified "each circuit", not "each wire". The operating current flow through each wire can easily saturate the magnetic path through the toroid. Place the toroid over the whole circuit instead, and the operating currents magnetic fields cancel each other, leaving the toroid to do its job. For low powered stations using typically RG-214 or semi-flexible Heliax™ or other 1/2" line, there are plenty of suitable ferrite toroids on the market. For higher powered installations, when toroids that are large enough to fit over larger transmission lines are not available, it is suggested that 1" lengths of steel pipe or steel electrical conduit, insulated from the line and from each other, are worth trying and may work almost as well. They should be provided with an air gap (a single cut with a hacksaw) to avoid saturation. You might want to measure the inductance and loss at, say, 2.5 MHz, of a single wire threaded through one of these gapped steel rings, and compare it with the measured inductance of a ferrite toroid.

Don't forget that ALL conductors and their sheathing or shielding extending up the tower are "incoming" for a lightning strike; they need suppressors and inductances. The outer conductor of every coaxial cable or transmission line, or the metallic sheath of mineral insulated or other multiconductor cable should be bonded (grounded) to the tower at frequent intervals to reduce probability of jacket puncture from the voltage gradients that could be developed between the cable and the tower, and these "outers and sheaths" definitely must be grounded to the tower base and to the building wall bulkhead plate. Rigid line is usually bonded to the tower with a metal strap or a line hanger placed every few flanges, mineral insulated cable sheathing is bonded with metallic fasteners, and plastic insulated cables must also have a metallic sheath.

Flexible line or sheathed jacketed cable is stripped of about 1" to 1 1/2" of its jacket at frequent (60-80 ft) intervals, a ground strap is connected to the cable outer conductor, then a special polymer tape is used to reseal and waterproof the jacket. Grounding kits contain all the materials required.

Broadcast antennas are usually grounded to the tower, so create few problems. Other antennas, such as some designs used for two-way radio, may connect directly to the center conductors of their cables and are insulated from ground. In any event, the center conductor of any coax, or conductors inside sheathing, can have high voltage induced in them due to a direct hit on the tower. For coax lines up to 3p" size, gas filled coaxial transient suppressors having good energy ratings and low VSWR are available from PolyPhaser, and for multiconductor cable there are also suitable suppressors offered. We don't intentionally wish to tout any particular vendor, but these products are highly recommended.

VHF AMPLIFIER INSTALLATION

3. LIGHTNING AND OTHER TRANSIENT PROTECTION - a tutorial: (continued).

Coaxial line and other tower circuit surge suppressors should be mounted on and grounded to the bulkhead, which must be well grounded (that means low inductance as well) with at least two, 150 mm x 1.5 mm copper straps to the tower ground system. Any bends in these straps should be as gradual as possible.

Be sure that all ground path impedances are as low as possible, and try to arrange the suppressor locations and their grounding conductors so that personnel cannot come in contact with them during a thunderstorm. This includes placement of grounded security fencing around the tower base, the line bridge, the bulkhead, and the guy anchors. Heavy copper wire or strap connecting to multiple grounding rods around the foundation of the building, and including one or two of the tower ground radials, will help to equalize voltage distribution and the strike currents underground. All suppressors and equipment ground connections, however, should be made to the bulkhead plate which is bonded to the tower ground system.

Commercial "surge suppressors" designed to connect to AC mains and other lines, are available in various ratings of voltages, currents, surge currents, and Joules. Some of these may contain MOV devices and ferrite toroids integrated together, which may be worthwhile because the ferrite provides the necessary impedance between the suppressor and the equipment, and avoids the need for sourcing at least two large toroids that will fit over the four large conductors needed by the typical 3 phase AC power service entrance. Other designs use air core inductors to avoid possible saturation of ferrite material from successive unidirectional lightning hits. At least one other brand includes high powered active filter circuits. Be sure to devote some of your time to investigation of the various suppressors available to suit your applications (you will indeed have several applications on site) before your decision is made.

It is not a good idea to go without suppressors, or without isolating impedances between the suppressors and the equipment, because there would then not be a controlled path for the lightning energy to follow, thus it is possible that the next hit could find an easier path through the PA module circuit components, power supply rectifiers, or power transformer insulation, and these items can become quite expensive.

Generally, gas protector devices are useful on circuits having relatively low voltage but higher source impedance, as in telephone and signalling systems. With special gases, they can be effective on 50 Ω lines, especially where the transmitter's VSWR protection shuts off the RF momentarily during the arc. AC power line source impedances are much too low for gas filled protector devices to function properly, because once an arc begins there, the gas plasma remains ionized long enough that the next AC half cycle conducts, then the next, etc, resulting in extremely high current flow through the gas. Surge suppressors using MOVs work best for AC power circuits.

The tower itself must have sufficiently low ground impedance that a major portion of the lightning energy goes to ground at the tower base or guy anchors, and only a small amount then needs to be dissipated in the suppressors. Locating the line bridge between the tower and the building as low as possible (1 meter or 3 to 4 ft above grade is suggested) will result in lower induced energy into all suppressors, and at the same time, the extra line needed indoors to reach from the top of the transmitter cabinet or patch panel, down to the bulkhead plate, will add desirable isolating inductance.

Many types of protection devices are available at a wide range of prices, but even the most expensive protection is extremely economical when compared with potential costs of off-air loss of revenue, and/or the costs of rebuilding or replacement of the equipment being protected.

You may also wish to consult with your power utility company engineers; their extensive experience with lightning and grounding would certainly qualify them to be able to advise you about these same subjects, and a phone call or FAX to the PolyPhaser people might also prove worthwhile.

PolyPhaser numbers: Phone 1-800-325-7170 or (702)-782-2511; and their FAX is (702)-782-4476.

VHF AMPLIFIER INSTALLATION

4. A FEW WORDS ABOUT POWER WIRING:

This transmitter requires a single phase power source. The transmitter power supply is a switcher type with autoranging AC input allowing it to operate in the ranges of 90 to 135 V or 180 to 270 V. Typical measured power consumption at black, amplifier only, is 200 VA at 49% PF for the TTS10B, and 285 VA at 49% PF for the TTS50B. The exciter, though, needs its primary taps set for appropriate line voltage, which must be within $\pm 10\%$ of nominal. Taps are at 100, 120, 130, 200, 210, 220, 230, 240, 250, and 260 V.

The standard design allows the transmitter to operate line-to-neutral from single phase 100 to 130 V. For operation in typical 50 Hz regions, where a 380 V or 416 V mains is available, the transmitter also would be connected to operate line-to-neutral. Line to neutral in 380 V 3 phase mains is 220 V, and in 416 V 3 phase mains, line to neutral is 240 V. Optionally (with added fuse 1F2) it can be operated line-to-line when used as a standby at a site where 208 V 3 phase power is available, or from single phase 115-0-115 V power.

All switcher power supplies use a large input filter capacitor, which is the reason for the poor power factor. "Power factor" is based on measurement of zero crossings of input voltage and input current, and 100 times the cosine of these zero crossings angular difference is the power factor in percent. As the switcher operates, the filter capacitor recharge current occurs in narrow high current peaks, so the current zero crossings obviously don't coincide with the voltage zero crossings. Furthermore, at startup, the capacitor has no stored charge and takes a large inrush current for the first few AC cycles to bring its stored charge up to a value enough for the supply to operate. Time delay fuses or circuit breakers are therefore necessary on the power line feeding the transmitter. Vendor specified voltage peak inrush current is about 55 amps.

For standard line-to-neutral operation, a fuse 1F1 is provided; for the TTS10B this fuse is 7 amps slow blow, and for the TTS50B the fuse is 12 amps slow blow. For the power source, we suggest that a slow trip breaker of 15 amps, rated for motor starting service, should be satisfactory. Even at lowest voltage the TTS50B transmitter and its exciter together should draw less than 5 amps, so a 15 amp breaker is adequate. For optional line-to-line operation, the transmitter is fitted with two fuses, 1F1 and 1F2.

A *sinusoidal output*, AC voltage regulator is recommended so that the exciter AC input remains within its $\pm 10\%$ limitation, especially at sites where line voltages fluctuate widely.

Regulators having variable transformers that work a buck-boost connection to the mains, provide sinusoidal outputs thus are the best regulators for the purpose. One small tradeoff is that some variable transformers are motor driven, thus may seem slow in correcting extremely wide variations in mains voltage. For most situations, most of the time, the mains voltage variation rate is slow enough that this is not of concern.

Motor driven regulator response speed is not usually critical, but there is one situation for this type of regulator that should be kept in mind: Many power failures are preceded by an abnormally low mains voltage with consequent highest output from the regulator, and upon restoration of power the output of the regulator will therefore be at its maximum for the length of time required for the regulator to respond.

To make matters worse, often the restored incoming mains voltage will be well above normal for several seconds. A power surge of extremely high voltage thus can be applied to the equipment.

There is a solution to this regulator response problem: The regulator should be specified to have *battery backup*, a *DC servo amplifier and DC motor* driving the variable transformer, and controller arrangements such that it will reset itself to its *LOWEST* output voltage *DURING* a power failure. The result will be that upon restoration, the output voltage will begin at its lowest value. This will avoid equipment overstress.

Setting of the regulator for tight regulation will cause it to correct often for small incoming voltage changes, which may result in increased brush wear in the variable transformer(s). Some regulators which have no brushes use special transformers in which two coils move in relation to each other. The original designs of these variable transformers came from General Electric and were called "Inductrol" regulators.

VHF AMPLIFIER INSTALLATION

4. A FEW WORDS ABOUT POWER WIRING: (continued).

Another company's design of regulator made use of a large number of thyristor devices to switch taps on a transformer winding, and would require at least two AC cycles for its controller circuit to decide which tap needed to be switched, with the result that small spikes were inherently part of the regulated output.

The TTS10B or TTS50B and its exciter have good internal regulation for wide extremes (nominal $\pm 10\%$) of incoming line voltage, but other on-site equipment may not be as forgiving of poor line regulation, and a voltage regulator is a desirable accessory. If the site mains voltage extremes are greater than 10% variation, a voltage regulator that has wide range input voltage specifications, should be considered mandatory.

5. VENTILATION/AIR CONDITIONING INFORMATION

At black level with full aural power, the maximum amount of heat is generated by the RF amplifier. This heat is removed by forced convection from the heatsink. A built-in blower pushes air through the heatsink, from which it is exhausted into the transmitter room. Care must be taken that the specified maximum transmitter ambient temperature of 45°C is not exceeded at any time.

The RF average power output delivered to the transmission line is almost 7 watts at black level with aural on, when the TTS10B transmitter is operating at its rated peak visual and 10% aural output. Subtracting this 7 W amount from the $(200 \text{ VA} \times .49 \text{ PF}) = 98 \text{ W}$ of AC power input, gives us the heat generated by all stages in the transmitter; about 90 W total. Add the 100 W exciter power input to this, and the total is about 190 W for the transmitter on the air. Likewise, the TTS50B delivers average power of 35 watts RF to the line and takes about $(285 \text{ VA} \times .49 \text{ PF}) = 140 \text{ W}$ of AC power input, which generates about 105 watts of heat, and with the exciter = 205 watts of heat when on the air. These equipment heat amounts do not include the heat dissipated by input and monitoring equipment, or other sources of heat in the room.

Due to the complexity of the entire discipline of "heating, ventilation and air conditioning" (HVAC), it is recommended for best results that the services of an experienced air conditioning contractor/engineer be engaged for the design and implementation of your building air conditioning or ventilation system. This is perhaps more important at shared sites using a single tower, such as for two-way radio, cell phone, telco, and/or other uses, such as in small communities where a studio installation may be in the same building.

For budgetary purposes, you may wish to perform this estimating exercise: Assuming a transmitter site only (no studio facilities), outdoor ambient temperature of 40°C, typically windowless concrete block walls, uninsulated precast concrete roof, and overall dimensions 16 ft x 20 ft x 11 ft, it would probably require about 2½ to 3 tons of refrigeration to keep the building habitable for an inside ambient of 20° to 25°C without equipment. This is equivalent to maybe 9 kW of heat, and equipment heat load adds to this, at a rate of 3413 BTU per hour for every kilowatt of heat, which works out to about 0.3 ton of refrigeration required to remove each kilowatt of heat. There are 12000 BTU per hour in a ton of refrigeration.

Transmitter heat is specified above, but the rack equipment and lighting loads are unspecified. Simply total the input power for this other equipment, since you can safely assume all its AC input gets converted into heat. Add the transmitter and exciter to this, add the result to the 9 kW for the building, multiply the total kW number by 0.3, round the result up to the next integral number, and that is your approximate tonnage.

Reference to mail order catalogs (Sears, etc) indicates approximately the price per half-ton for a 6000 BTU window mount air conditioner. We don't recommend window mount air conditioners because they are not designed for unattended continuous duty and they are difficult to service, but the catalog list price is a start. This price per half-ton must then be multiplied by two and then by your integral number of tons. The result of this math represents a continuously running system; multiply again by two for main-alternate.

VHF AMPLIFIER INSTALLATION

The resulting total gives you an approximate equipment cost, less installation. Your air conditioning contractor should then be asked for an official estimate, including installation and warranty.

6. FIRE PROTECTION

Some persons may think that the following material is totally overdone for a low powered transmitter site; indeed, many such sites are in remote regions of the country and would probably sustain far more damage from forest fires than from fires originating in the equipment or elsewhere inside the building. Nevertheless, you may find something of technical interest in this part, even though some of it may not be relevant to you.

Transmitter interlock connections are on TB2-3 and TB2-4 on the back of the amplifier chassis. These connections form a series path for "External Interlock #1" which enables the transmitter's control circuit, including its blower. Because the air is simply exhausted to the room, in case of fire the current of air from the transmitter may fan the flames, so it is desirable that the blower be stopped. A fire alarm system should be able to be arranged to provide a set of normally closed dry contacts to connect into this interlocking circuit; it is recommended that this be done.

Other alarm system contacts may also be needed for various purposes separate from the transmitter. These extra alarm system contacts may be needed to shut down other air systems in the building, to close air dampers and fire doors, and to enable activation of automatic firefighting apparatus, if provided. One extra set of dry contacts should be made available for reporting of the fire through the remote control.

Building designers once thought that a fire alarm system needed only to trip the main AC breaker to the building, which would automatically stop all fans and blowers. As long as the fire is prevented from spreading by ensuring all blowers are stopped and air dampers closed, and fire doors are closed, there is no reason that AC cannot remain on, to keep lighting available for evacuation of personnel.

For installations where the transmitter is located on top of a tall building, the main AC should never be able to be tripped by a fire alarm, because doing this can also stop elevators full of people, sometimes between floors. Fire alarm systems for these situations should be engineered by specialists.

It is assumed that if an emergency alternator is installed at the station, it is located in either a separate building, a fire proof vault with its own separate ventilation, or in its own enclosure, and is fitted with its own fire protection systems, so the above air system considerations would not apply to it. Specific building codes may apply to it though, particularly regarding its fuel supply. It is well to check with your fire chief, fire marshal's office, and/or building inspector for applicable code requirements.

The transmitter plant, particularly those using higher powered transmitting equipment, represents too large an investment to neglect its fire protection, especially for unattended sites having difficult access. Investigation of available fire alarm and fire fighting systems should be carried out as early in the design process as possible, and well before final design commitment. Your local fire chief or fire marshal's office may be helpful sources of advice during planning of your installation.

Even if the site is normally unattended, it must be mandatory that any automatically activated fire fighting system can be disabled whenever personnel are working in the space protected by the system. Most systems for use with electrical apparatus, depend on the high pressure discharge of carbon dioxide, halogenated hydrocarbons such as Halon™, carbon tetrachloride, or other equally deadly extinguisher gases into a closed equipment room; this puts a fire out by displacing all oxygen. *Obviously, the design must be fail-safe, because when personnel are working in the room, they must never under any circumstances be exposed to a risk of system malfunction which could be fatal.* Check this out; it's important.

VHF AMPLIFIER INSTALLATION

7. UNPACKING

Carefully inspect each package as it is received, for possible shipping damage. Claims for damaged equipment must be filed with the carrier within seven days of delivery or the claims will not be accepted.

Unless specific contractual arrangements for title, FOB location, etc. have been made, generally the delivery of the equipment to the carrier by LARCAN INC. constitutes transfer of title to the customer, and it is therefore customer responsibility to ensure that any such claims are promptly filed directly with the carrier.

Check the equipment received against the shipping list. Should there appear to be a shipping error or if replacement equipment must be ordered due to transportation damage, notify your LARCAN representative as soon as possible.

If construction or renovation work at the transmitter site is not complete by the time the equipment is received, repack all equipment items after their inspection and store them in a clean, safe, dry area to avoid harm to any of the equipment. Repacking for storage should be performed in such manner to prevent access by mice and other small animals which can damage wire coverings. Construction debris such as plaster dust, metal filings, and other abrasive contaminants entering the equipment can also cause damage.

When the construction work is complete, the area should be cleared of all dirt and debris, and vacuumed thoroughly before the equipment is installed. Plain concrete floors should be sealed or tiled to prevent surface dust from being drawn into the equipment.

When the installation work is complete, the area should again be cleared of all debris and vacuumed once more, before any of the equipment is initially turned on. Check for loose screws and connections, and tighten where necessary.

Finally, before powering up, be certain that all tools, surplus and scrap installation materials, stray hardware, stray "blobs" of solder, ends cut from wires, stripped wire insulation, and other trash, are completely removed from inside the cabinets.

8. TRANSMITTER EXTERNAL INTERLOCK CONNECTIONS:

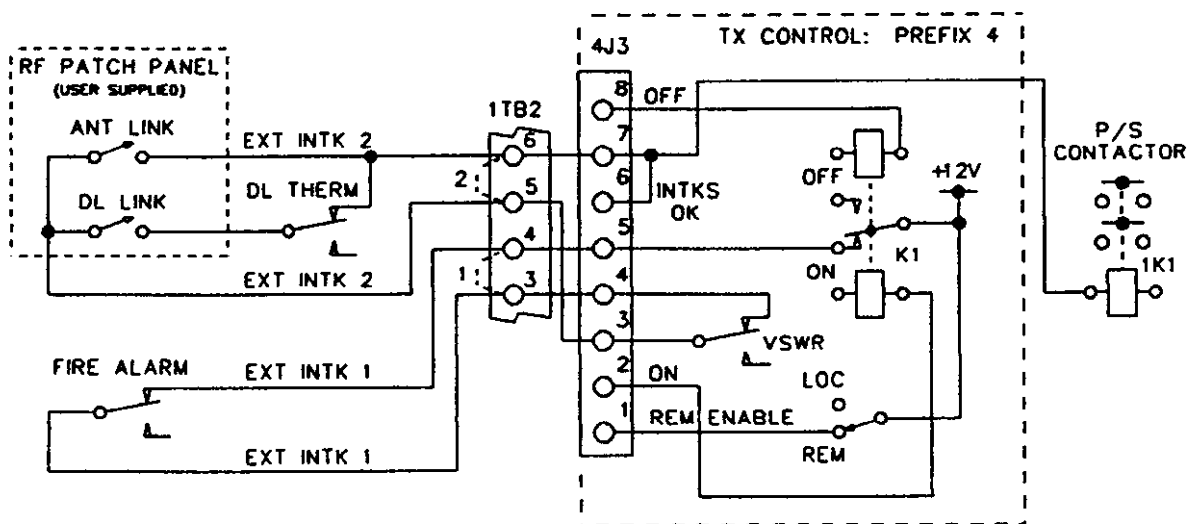

Figure 1: TTS10B and TTS50B Transmitter Interlock Connections.

VHF AMPLIFIER INSTALLATION

We will be the first to admit that many people think "interlocking" is overdoing it for such low powered equipment, therefore we have shown dashed line jumpers 1 and 2 for you to use in lieu of interlocks. Just in case you DO need interlocks, such as when the amplifier is a driver for a high powered linear, know this: All interlocks are low energy, 12 VDC, and currents are in the order of about 250 milliamperes. Connections shown are functionally compatible with interlocks for other LARCAN transmitters, as follows.

Normally-closed contacts from the building fire alarm system should connect to "Ext Interlock 1" (1TB2-3,4) which will shut down the whole transmitter, including its blower. This fire alarm contact could connect in series with any patch panel and dummy load interlock wiring, or if wiring can be made easier, the patch panel and dummy load interlocks could connect for convenience to "Ext Interlock 2" (1TB2-5,6) as shown. Transmitter operation is identical from either; the only difference between these interlocks is in the status indications seen by both the observer of the transmitter control panel, and by the remote control system.

9. FIRST-TIME, ON-SITE TRANSMITTER START-UP PROCEDURE:

If you have not already done so, please take the time to read and understand the technical Sections of this manual, which contain information that you might want or need when you first start your newly installed transmitter. Read them again, just to be certain nothing was overlooked. The amplifier meter was calibrated to read 100% with the visual and aural present.

1. Connect the transmitter output to a 50 ohm dummy load or the antenna. The transmitter uses a 50 Ω type N connector for its output. An inline wattmeter with a selection of detector elements should be used for measurements.
2. Transmitters only: Connect a 1 V peak-to-peak video signal to the modulator video input jack. Connect an audio signal to the modulator audio input. Connect the RF output to the input of the amplifier.

Translator only: Connect the input channel signal to the input of the channel processor, and its RF output to the input of the amplifier.
3. Connect the 115 VAC mains input. This AC circuit should be rated for 15 amperes, and should be supplied through a slow tripping breaker or time delay fuse. Generally, a breaker that is rated for across-the-line motor starting will be found to be satisfactory.
4. Depress the amplifier ON push button. The three LEDs marked EXT1, TEMP, and EXT2 should be lighted, and the amplifier power supply should be operating. Verify this by observing the blower, which is powered by the amplifier power supply and therefore should be running.
5. The amplifier is equipped with overpower and VSWR protections which have been factory set. To set the correct level on the channel processor/exciter, simply adjust the level control so that the output of the amplifier just reaches 100%.
6. For amplifiers equipped with AGC (later model with AGC ADJ level control), initially set the operation on manual by pushing the AGC switch such that the AGC switch LED is not lit. Adjust the channel processor/exciter level for a reading of 110%.
7. Switch to AGC operation (AGC switch lit) and adjust the AGC ADJ potentiometer on the amplifier front panel for a meter reading of 100%.

VHF AMPLIFIER INSTALLATION

Notes:

AMPLIFIER RF OUTPUT BANDPASS FILTER and DIRECTIONAL COUPLER

Contents:

Sec	Topic	Page
1	HB Helical Resonator Bandpass Filter Description (50W HB only)	31-1
2	HB Low Power Bandpass Filter Description	31-3
3	LB Low Pass & Notch Filter Description	31-4
4	RF Directional Coupler Description	31-5

List of Figures:

Fig	Title	Drawing Reference
1	Bandpass Filter response	text, page 31-2
2	Bandpass Filter schematic	text, page 31-3
3	RF Directional Coupler schematic	text, page 8-6
4	Generic Helical Resonator Bandpass Filter Assembly	30C1064 sht 2
5	High Band Bandpass Filter Assembly	20B704 sht 1
	High Band Bandpass Filter Schematic	10A769 sht 1
6	Low Band Bandpass & Notch Filter Assembly	20B1118 sht 1
	Low Band Bandpass & Notch Filter Component locations	20B1120 sht 1
7	Low Band Bandpass & Notch Filter Schematic	20B1151 sht 1
8	RF Directional Coupler Assembly	20B534 sht 4
	Low Band Coupler PC Board Assembly	10A1942 sht 1

1. **30C1064G1 Helical Resonator Bandpass Filter (used with 50 watt High Band):**

The helical resonator was developed during the late 1950's and first described in "Proceedings of the IRE" magazine by W. W. McAlpine and R. O. Schildknecht, "Coaxial Resonators with Helical Inner Conductor," *Proceedings of the IRE, vol. 47, no. 12, pp. 2099-2105; December, 1959*. The same authors later published another magazine article "Helical Resonator Design Chart," *Electronics, p. 140; 12 August 1960*.

IRE stood for the "Institute of Radio Engineers" which was responsible for some of the television transmission standards that remain in use today. IRE later merged with the "American Institute of Electrical Engineers" to become the "Institute of Electrical and Electronic Engineers" which is known to us as the "I-triple-E" and which continues publication of important electrical and electronic engineering research papers in the "Proceedings of the IEEE" and in the "IEEE Transactions" dealing with electrical and electronics interests.

We generally avoid such papers in our manuals except for the rare instance where critical information is involved, as the content of most of these publications are considered to be excessively arcane and esoteric for the beleaguered technician whose sole interest is to get the transmitter back on the air. Should you wish further information, we refer you to the above cited publications, to "Reference Data for Radio Engineers, sixth edition" published by Howard W. Sams & Co., and to the "ARRL Radio Amateur's Handbook" published annually by the American Radio Relay League.

AMPLIFIER RF OUTPUT BANDPASS FILTER and DIRECTIONAL COUPLER

1. Bandpass Filter: (continued).

LARCAN bandpass filter implementations generally consist of a cascaded series of coupled resonators. Some use helical resonators; essentially a self supporting high Q coil (the helix) mounted inside a metallic shield enclosure. One end of the coil is solidly connected to the shield enclosure and the other end is open circuited except for a small trimmer capacitance to ground. The dimensions of the coil are critical to the frequency of operation; the assembly behaves as though it were a quarter wave coaxial transmission line resonator. Several sizes of coils and enclosures are necessary to cover the desired frequency ranges.

Fold-out Figure 4 indicates the generic assembly of a coupled helical resonator bandpass filter. The referenced drawing in Figure 4 happens to be a low band filter, but the high band unit is laid out identically and appears almost the same as Figure 4 except the high band helixes have fewer turns of coarser winding pitch, and their shield enclosure dimensions are somewhat smaller.

The desired response shape is presented as Figure 1 below, and the filter electrical equivalents are presented on the next page as Figure 2. When we examine the assembly, and take capacitances into account, the equivalent circuit of a helical resonator becomes simply a parallel resonant LC tank circuit having low (trimmer) capacitance and relatively high inductance. Adjustment of the trimmer produces a change of capacitance, and the trimmer's moveable slug is shaped to appear as a shorted turn, which alters the inductance of the helix.

Matching from and to 50 ohm transmission lines is accomplished with taps on the input and output helixes.

Coupling between sections is electrically a bridged T network of capacitors, and is made up of the small capacitance between the free ends of the coils, controllable by the amount of capacitance to ground that is introduced by the coupling adjustment screws; the coupling is maximum when the screws are backed out fully from the enclosure. Shielding partitions placed inside the enclosure between helixes, produce fixed area apertures which affect the coupling capacitance between helixes. Helix #3 in the Figure 4 drawing has taller partitions on both sides of it, giving lower capacitance and less coupling than the others.

For system use, the tuning and coupling is adjusted for a flat topped response with steep sides, and the desired shape is such that $f_v - 4.5$ MHz and $f_v + 9.0$ MHz are both 30 dB down, but the carriers must be $f_v < 0.6$ dB and $f_A < 0.7$ dB departure from flatness. Input and output return loss must be 20 dB or better over the full 6 MHz bandwidth. These idyllic sweep curves are shown below as Figure 1.

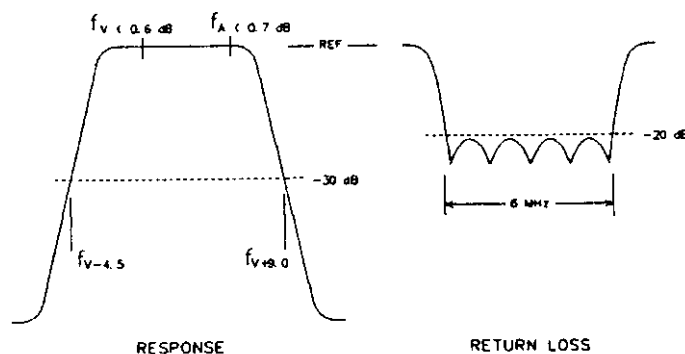

Figure 1: 5-Pole Bandpass Filter Curves.

There are nine screw adjustments and two I/O matching (with soldering iron) adjustments that need to be made simultaneously, and unfortunately all of them interact with each other. To make these adjustments properly, a network analyzer is mandatory, and because this is an expensive piece of test equipment not likely to be available in the field, for this reason we say the unit is not user-adjustable. Our recommendation: don't mess with the filter adjustments at all.

AMPLIFIER RF OUTPUT BANDPASS FILTER and DIRECTIONAL COUPLER

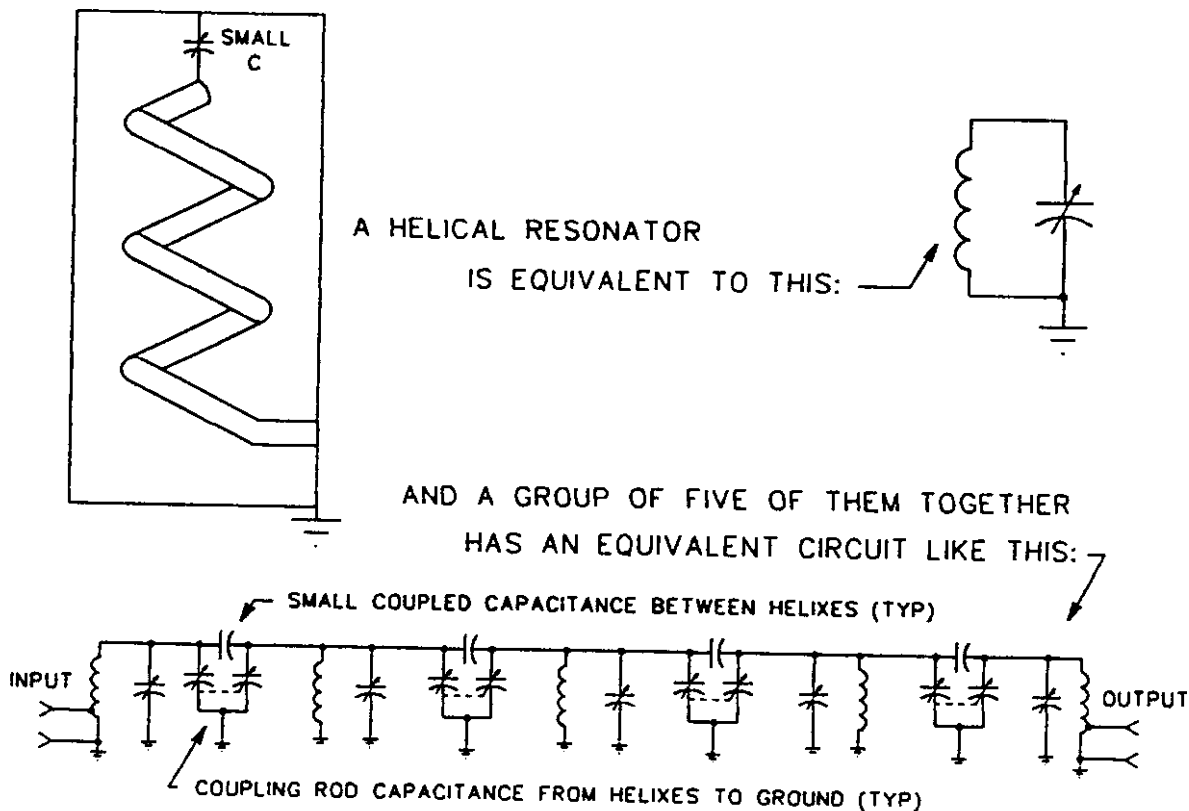

Figure 2: Typical 5-Pole Bandpass Filter.

This is the electrical equivalent of a series of five coupled helical resonators. Similar lower power filters are built using conventional air wound coils and ceramic trimmer capacitors, and these will be described next:

2. 20B704G1 Low Power Bandpass Filter for High Band:

Please refer to Figure 5. The configuration of this filter is similar to the previously described helical resonator type in that it uses five LC resonant circuits, but it differs in that two of these resonant circuits behave as high Q traps for frequencies outside the band edge (-4.5 and +9 MHz), so that the overall response has a reasonably flat top and steep sides. Factory adjustment is made to achieve the same in-band response (carriers must be $f_v < 0.6$ dB and $f_A < 0.7$ dB departure from flatness) as described for the helical resonator filter. (We would have preferred to use this 20B704G1 filter for the 50 watt high band system as well, except that the ceramic trimmers overheated due to the higher RF currents at the 50 watt level, so the decision was made to go with the higher power helical resonator filter for 50 watt high band transmitters).

Like the helical resonator filter, there are nine screw adjustments and two I/O matching (with soldering iron) adjustments that need to be made simultaneously, and all of them are interactive. Accurate adjustment is impossible without the aid of a network analyzer, and because of the expense of this gear it is not as likely to be available in the field; for this reason we say the filter is not user-adjustable.

Sure, it is possible to use a sweep generator and detector for setting the response of either filter, but unless an accurate 50 ohm return loss bridge is used with the sweep generator, there is no way to properly set up the input and output matching. Our recommendation: don't mess with the filter adjustments at all.

AMPLIFIER RF OUTPUT BANDPASS FILTER and DIRECTIONAL COUPLER

3. 20B1118G1 Low Pass and Notch Filter for Low Band:

Please refer to Figures 6 and 7. Ten adjustable inductors, four fixed inductors (which also can be adjusted slightly by spreading their turns with a suitable tool), and twenty-one fixed capacitors, make up the complete filter. Functionally, it consists of two sections of shunt m -derived low pass network, followed by four bridged-tee notch networks. Its signal direction is intended to be one way only, as indicated in Figure 7.

The low pass section (L1, L2, C1 thru C5) of the filter is designed to cut off at a frequency lower than the second harmonic, so that only the fundamental is able to pass through, but harmonics are blocked.

The four notch sections are tuned to reject f_v-9 , $f_v-4.5$, f_v+9 , and $f_v+13.5$ MHz (down typically 18, 30, 24, and 26 dB respectively - sometimes one of the tuned circuits at f_v-9 , either L3 or L5, is readjusted to $f_v-4.5$ in order to make that notch deep enough that the $f_v-3.58$ MHz component is sufficiently attenuated).

L4, L7, L10, and L13 are adjusted to set the width and depth of the notch. A typical network analyzer transfer function plot of the filter indicates the four notches at the values stated above, and the band pass of the f_v and f_A frequencies and the channel between, having less than 0.1 dB of ripple.

If your particular filter appears to be missing some of its capacitors, don't be concerned. Probably the "missing" ones are chip capacitors soldered to the pads on the underside of the board. The circuit board is a mature design which was made before surface mount components were in widespread use; occasionally we run out of low value capacitors having leads. Most RF parts used these days are surface mount.

Due to the large number of interacting adjustments in this filter, we recommend DON'T MESS WITH IT.

AMPLIFIER RF OUTPUT BANDPASS FILTER and DIRECTIONAL COUPLER

4. RF Directional Coupler:

A directional coupler is based on the principles of inductive (magnetic) coupling and capacitive coupling.

In the LARCAN quad directional coupler implementation as shown in Figure 3 (schematic equivalent) and Figure 8 (assembly), the RF to be sampled passes through a microstrip transmission line that is connected between the transmitter output filter at J3 and the antenna system at J4. The magnetic field surrounding the hot conductor of this transmission line induces a small RF current flow in other conductors situated parallel to it. One end of each sampling conductor is terminated by a resistor to ground. Sometimes small capacitors are connected across these resistors to provide a termination that remains resistive over the band. The other end of each sampling conductor connects to an external load, usually a 50 Ω input of something such as an RF detector for AGC, the station demodulator, or an RF detector for VSWR sensing.

If the sampling system as described in the forgoing paragraph were dependent only on magnetic coupling and absolutely no capacitance were present, the external loads would be driven with RF samples regardless of the direction they came from. Omnidirectionality is not wanted; our objective is that the system should be directional, that is, a signal coming from the transmitter should be seen by the "forward" ports, and a signal reflected back from the antenna should be seen by the "reflected" ports, but at the same time as little as possible of the forward signal from the transmitter should be seen on these reflected ports.

The desired directivity is achieved by the capacitance between the main line and each sampling line. The presence of this capacitance changes the relative phase of the RF signal seen in the sampling line such that *the capacitively coupled signal adds to the inductively coupled signal at the end of the line nearest the signal source, and subtracts from it at the other end, thus the sample becomes directive.*

This capacitance is trimmed by small "gimmick" capacitors designated (believe it or not) L1 thru L4. This designation arose from a mistaken belief that "inductances are made of wire; ergo, these are inductances." They are in reality short pieces of Teflon sleeved magnet wire which, although they may possess a fraction of a nanohenry of inductance, are mainly small capacitors which are factory adjusted by bending the wire to control the amount of coupling capacitance between the transmission line and the sampling loop concerned. The position of the capacitor along the loop does not seem to matter.

Terminations are provided at the subtractive ends of each of the four sampling lines.

In the enclosure shown in Figure 4, J3 and J4 are the filter and antenna ports respectively, and J1, J5 are "forward" samples which are maximum amplitude for signals incident on J3; while J2, J6 are "reflected" samples which are maximum amplitude for signals incident on J4.

Different coupling values are obtained from the spacing of conductors; the nearer the spacing, the greater the coupling. Coupling is also greater according to frequency, and rises at a rate of about 6 dB per octave. In the boards shown in Figure 4, the J1 and J2 signals will be about 10 dB greater amplitude (about 36 dB below the generator level at 70 MHz on low band or 200 MHz on high band) than the signals sampled from J5 and J6 (about -46 dB). Generally for system purposes the reflected signal sample to the VSWR supervisory system should be taken from the J2 connector because it has greater coupling and we need to measure a much smaller signal in a detector having finite small-signal sensitivity. System forward signals can be taken from J1 for the AGC detector, and J5 for the system monitoring demodulator.

A network analyzer and extremely accurate terminations are required for setting up the directional coupler. The adjustments are made to the trimming capacitances "L1" thru "L4", and the capacitors in parallel with resistors R1 through R4. Our target is directivity of 30 dB or better on each sampling port, and coupling (forward direction) for J1 and J2 about 36 dB down, J5 and J6 about 46 dB down.

No user adjustments are possible nor recommended. Very little can go wrong with the directional coupler other than from the antenna being hit by lightning, and inspection is all that is recommended, nothing more.

AMPLIFIER RF OUTPUT BANDPASS FILTER and DIRECTIONAL COUPLER

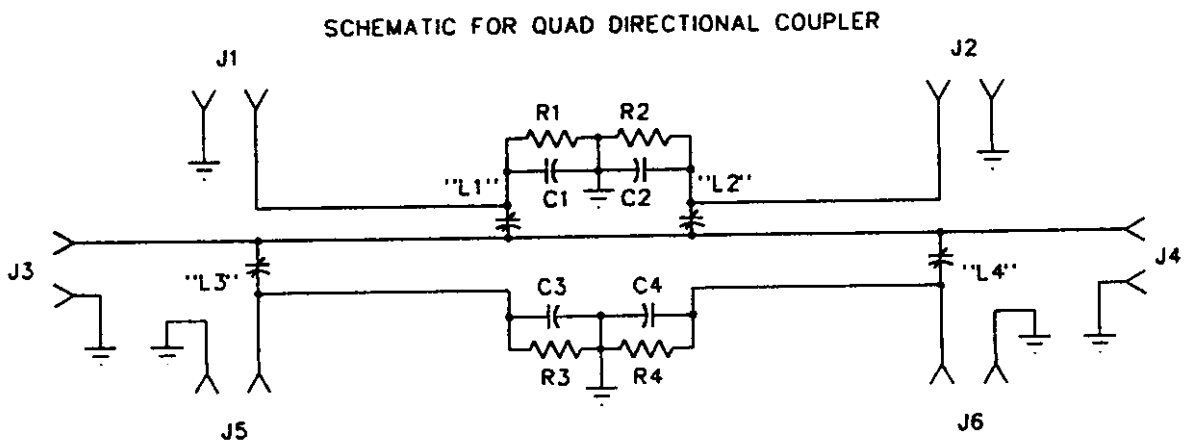

Figure 3: Quad Directional Coupler equivalent Schematic.

DWG. NO.

LARCAN

10A1252

TITLE

SCHEMATIC - DIRECTIONAL COUPL.

FMF 6KW, 22KW

REVISIONS

1	RN-88-090 .ADDED E3, E4.	JUNE 28/88 J.M.
2	RN95-157	28 JUNE 95
3	RN98-412 ADDED G4	15 DEC 98 RM

(G4)

- OMIT T2, E4, R2, C1, C41, R3, C2, E2

- INSTALL JP2, E4

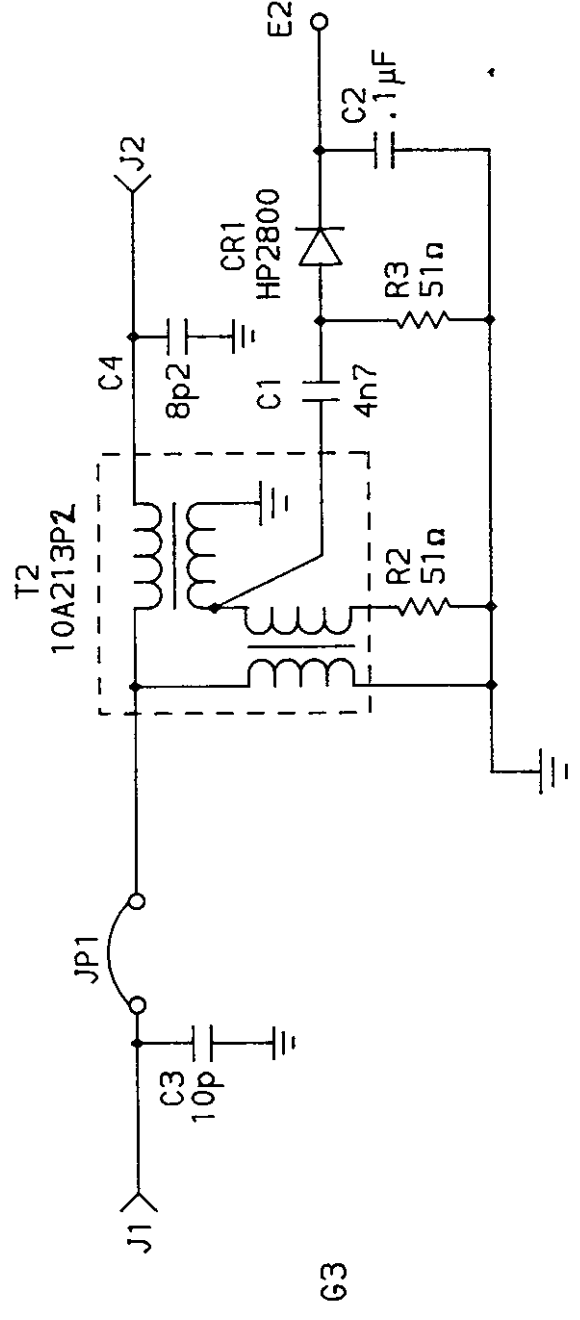
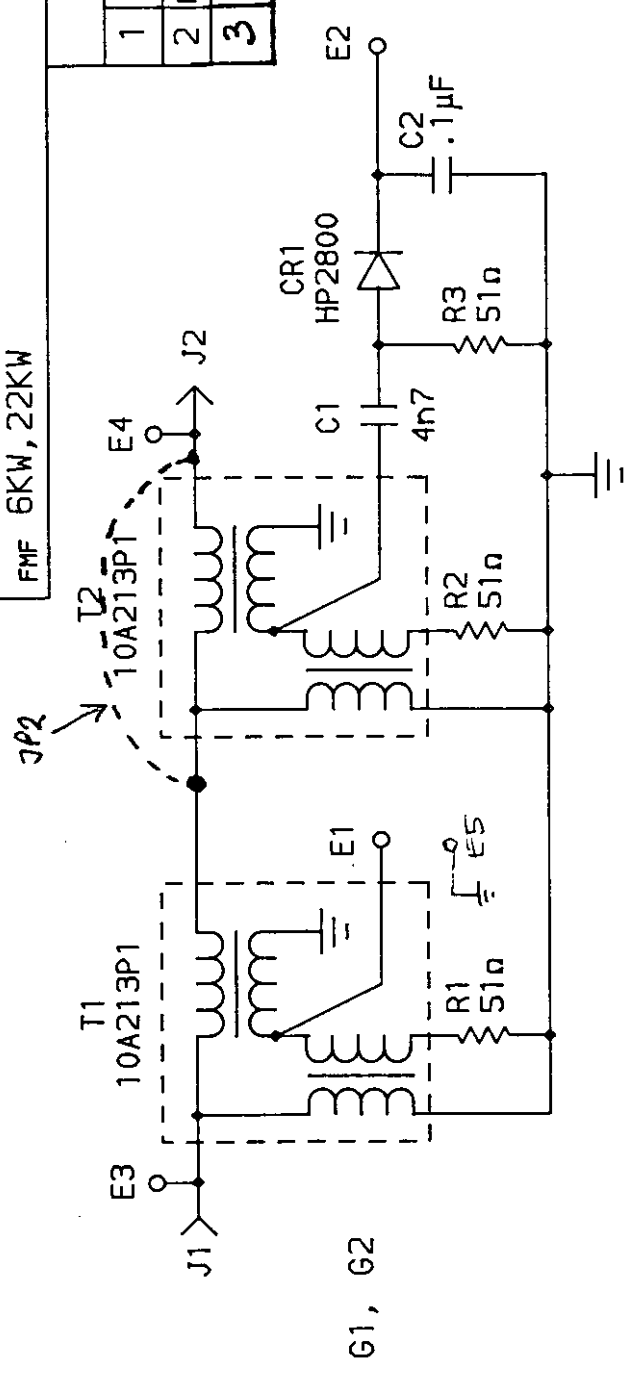

DRAWN by	J Barras	CHECKED by	J.E.T.
DATE	JAN. 5/87	SCALE	NONE

REF. FILE PATH MECH>JOSIE

BASIC TRANSMITTER MAINTENANCE

Contents:

Sec	Topic	Page
1	General	1
2	Daily	1
3	Weekly	2
4	Monthly	2
5	Semi-Annually and Annually	2
6	Transmitter Cooling System	2
7	Static 1, Equipment 0: A brief Static Tutorial	3
8	FET and Surface Mount Replacement	4
9	Replacement Parts	7
10	Spare Parts Recommendations, 10W VHF AMPLIFIER composite spares list	9

1. GENERAL

When the transmitter was installed and commissioned it was in proper operating condition. During final tests, all circuits were checked for optimum adjustment to ensure both peak performance and conservative operation of components, and test results were recorded for future reference.

Given reasonable care and attention the transmitter will provide efficient and reliable service for many years.

Experience indicates that equipment which is regularly and carefully maintained is far less likely to be subject to sudden failure than that which is operated continuously without regard to basic maintenance requirements. It is therefore desirable that a detailed preventive maintenance program be established to ensure that the original efficiency and picture quality is maintained throughout the life of the equipment.

Preventive maintenance techniques do not necessarily involve extensive dismantling of the various assemblies; on the contrary, this practice is to be discouraged unless a valid reason exists for doing so. Preventive maintenance is more concerned with detailed physical inspection and the general observation of the equipment during and after operation, to detect the presence of any abnormality which if not corrected might later develop more serious proportions, resulting in operational failure.

In preparing any maintenance program, the frequency and scope of the inspections must be determined, and to a great degree will be influenced by site location and the station's market parameters consequently its hours of operation, equipment configuration, and technical personnel deployment. For example, is the station on the air for 24 hours a day, are there main/standby transmitters, and are they attended or unattended? In general, the following routines should form the basis of any maintenance program.

2. DAILY

At an attended site, the operator is afforded the opportunity to make daily or more frequent checks on the equipment and thereby increase his/her familiarity with its operation. The "transmitter log" entries made during these checks would include all meter readings, also any irregularity in performance, or in picture quality, for later analysis. An unattended site where equipment is operated by remote control, and monitored by telemetry and a high quality off-air receiver or demodulator located within the primary coverage area at the studio site, can also be continuously checked for performance by studio technical personnel, using VITS or VBI test signals encoded into the video signal vertical blanking interval.

BASIC TRANSMITTER MAINTENANCE

3. WEEKLY

If the site is unattended, and VITS or VBI test equipment is not available, many broadcasters schedule their operational tests and transmitter inspections to be performed once a week during weekend hours, such as from midnight Sunday to six AM Monday, depending on their market conditions.

If there is an emergency alternator, it should be checked out completely, and run for at least an hour under full load. The checking of this unit should include the condition of its battery, its ease of starting (and its Winter starting enhancers such as block heater, battery warmer, fuel antifreeze), its engine oil level and condition (see "Monthly" below), its radiator coolant condition and level; and its fuel tank should be topped up. This simple check will serve as a reminder to order more fuel if necessary.

4. MONTHLY

In addition to the normal operational tests, thorough physical inspection of every piece of equipment should be made, with all power turned off. All surfaces should be dusted off or wiped down, terminal boards checked for loose connections, and all components examined for any evidence of overheating. Air filter media should be inspected and replaced if necessary. High pressure air, not over 20 psi, may be used with discretion to dislodge dust from inaccessible places.

Change the engine oil and oil filter in the emergency alternator, if it has been operated longer than its manufacturer's recommended time since this was last done. In the absence of recommendations, don't let it run more than about 100 hours between oil changes. When put into perspective, 100 hours is the time logged by a vehicle running 6000 miles at 60 mph. Oil is cheap, when compared with engine parts.

5. SEMI-ANNUALLY and ANNUALLY

Check all external RF connections for tightness. Test the antenna and transmission line with a transmission test set or network analyzer if one is available, to identify any potential problems with the antenna or line. Inspect and clean contacts on all switches and contactors; carefully redress contact surfaces if pitted.

Change the engine oil in the emergency alternator to summer or winter grade, depending on the season. Also inspect and if necessary replace, its fuel filter and air filters.

Inspection and maintenance (tighten all bolts, replace obstruction light bulbs) of the tower, antenna, and grounding system, should be conducted annually.

6. TRANSMITTER COOLING SYSTEM

Air filter material supplied with some transmitter cabinets has been impregnated with a polyester coating, which is designed to attract and hold very fine particles that may be in the air flow. This air filter material should be inspected every month or oftener, and replaced when dirty. Frequency of inspection and replacement, of course, will depend on your particular local environmental conditions.

All cooling fans in the transmitter are Rotron™ or equivalent, and all are fitted with sealed bearings requiring no lubrication during the lifetime of the motor.

BASIC TRANSMITTER MAINTENANCE

7. STATIC 1, EQUIPMENT 0: Static vs Sensitive devices...

Care must be taken at all times because this equipment contains static-sensitive CMOS and FET devices. Here is a brief tutorial on static, particularly pertinent to CMOS and other MOS device handling:

1. It is important to avoid surroundings or situations in which static can be generated. The building floor should have grounded conductive floor coverings, or a grounded conductive mat placed on the floor in front of the bench. Then, the bench itself should also have a grounded conductive mat on which the equipment is placed. Anybody working on the equipment should wear either a grounded wrist strap (preferably) or conductive overshoes. Vacuum cleaner tools should all be conductive and grounded to avoid static from air motion. (Vacuum cleaners made for computer servicing would be suitable). Soldering iron tips must be grounded. Use properly maintained soldering equipment that has a three wire, grounding plug, verifying low path resistance between ground and the tip with an ohmmeter every time this equipment is used.
2. The average person wearing rubber-soled shoes and walking across a woolen or synthetic carpet or untreated vinyl tiled floor is able to generate voltages in excess of 15 to 20 kV. Most MOS devices will suffer puncture of the oxide insulating their gates, at 20 to 40 V. Many CMOS devices are fabricated with built-in zeners which will clamp foreign voltages, but the amount of energy that must be dissipated may easily exceed the rating of this protection. It is therefore prudent to assume that little or no static protection exists in a CMOS device and therefore you must provide your own.
3. A typical unprotected gate of a CMOS logic IC has an input capacitance of about 5 pF and can self-immolate at 20 V, so the energy to destroy the IC is given by the expression $W = CV^2/2$ where W is in watt-seconds, C is in farads, and V is in volts. One watt-second is also known as a Joule. Substituting numeric quantities results in $W = 5 \times 10^{-12} \times 20 \times 20 \div 2 = 1 \times 10^{-9}$ Joule per gate. Stored energy in the approximately 100 pF capacitance of the human body charged to 15 kV, becomes $W = 100 \times 10^{-12} \times 15000 \times 15000 \div 2 = 11.25 \times 10^{-3}$ Joule. *Eleven and a quarter million times more energy than is needed to destroy one gate input!* Some of us may therefore be led to conclude that a body can annihilate more than eleven million CMOS gate oxides all at once.
4. This is serious stuff. To avoid destroying CMOS devices, the human body must be grounded first. That is the reason for all the "grounded surroundings" we suggest in paragraph 1. Don't forget, though, that a circuit board has conductive metallic paths connecting into the CMOS parts, which makes them all susceptible to mass devastation as easily as would be the destruction of any one CMOS chip all by itself. Always ground yourself first, then the board.
5. Avoidance of static exposure of boards and CMOS devices is easier. Ensure that boards are always kept in conductive bags or boxes when not in place in the equipment, and that spare CMOS ICs are in conductive chip carriers or plugged into conductive foam. Be careful about this point; many plastic foams can be coloured black, but may still be an insulator. Use your ohmmeter to be sure.

Don't accept any devices whose pins are punched through aluminum foil into foam plastic. People who don't know better have used this method for shipment and storage of devices, but it cannot be depended upon, because many times the holes made in the foil by the device pins become enlarged simply from the motion of pressing the pins into the foam, and won't make contact any longer. When the device is withdrawn from the foam, the friction of the plastic against the pin can generate enough charge to cause puncture and consequent failure of the CMOS gate insulation.
6. Identical statements to those made in the above paragraphs apply to RF power MOSFETs, and although the gates of these devices might appear to be considerably more robust than those of the average CMOS logic device, this is due only to the much greater gate area and consequently greater input capacitance. The same order of magnitude of gate oxide breakdown voltage exists for RF power FETs as for small CMOS devices, therefore use the same order of care in handling.

BASIC TRANSMITTER MAINTENANCE

7. STATIC 1, EQUIPMENT 0: Static vs Sensitive devices... (continued).

7. Believe it or not, ordinary analog meters can also be affected by static. Years ago, meters were made with glass faceplates and had movements that were relatively insensitive, so were affected little by stray static charges accumulating on the glass. Today, almost all meters are made with clear plastic faceplates and many of these, such as the sensitive 50 μ A ones we use, have extremely compliant moving parts, thus can be easily caused to read incorrectly from a static charge on their front surfaces. This charge can be readily generated by simply cleaning the meter face.

It is important that meter accuracy be maintained within reasonable tolerances, because you as a broadcaster are responsible for ensuring that the transmitter complies with all regulations pertinent to its operation, and the easiest way of tracking its performance is from its meter readings.

It is recommended for better accuracy that meter faces be given an anti-static treatment, either by cleaning with an antistatic cleaning agent, or sprayed with an antistatic coating, or both.

Suitable antistatic chemicals should be available through your nearest electronics parts distributor, and typically carry such names as "Zero Charge" from Tech Spray™, "Destaticizing Lens Cleaner" from G-C™, and "420 Antistatic Screen Cleaner" from M.G. Chemicals™. Check them out. Similar brands should also be available in most reputable computer shops or office supply stores.

CAUTION: Antistatic cleaners or treatment chemicals must not contain organic solvents such as acetone, MEK, methyl isobutyl ketone, benzene, toluene, xylene, ethyl cellosolve acetate, or many of the chlorinated hydrocarbons including ethylene dichloride and 1,1,1 trichloroethane, as these solvents will etch or even dissolve most of the plastics used for meter faceplates.

Our meter supplier recommends and uses a harmless coating treatment which it keeps in stock under its catalog number FS 681. This coating is otherwise known to the trade as ANSTAC 2-M.

ANSTAC 2-M is made by
Chemical Development Corp.
22 Portsmouth Rd.
Amesbury MA 01913 U.S.A.
Phone (508) 388-2221.

8. FIELD REPLACEMENT OF FETs and SURFACE MOUNT COMPONENTS:

TOXIC MATERIALS WARNING... Thermal management in certain RF devices in this equipment is accomplished through the use of Beryllium Oxide ceramic material. Beryllium Oxide is a hard white ceramic used as insulation for heatsinking of RF power semiconductors. *Beryllium Oxide is a POISON if taken into the body. In case of accidental breakage, DO NOT INHALE THE RESULTING BERYLLIUM DUST and AVOID GETTING BERYLLIUM DUST IN YOUR MOUTH. DO NOT LET BERYLLIUM DUST INTO YOUR BLOOD STREAM THROUGH CUTS OR OPEN WOUNDS !! Seek and get IMMEDIATE medical attention if the dust enters your body in any manner. Avoid cuts by wearing gloves while picking up the broken pieces. Be careful - do not inhale dust while replacing or emptying vacuum cleaner filter bags, and wash your hands thoroughly afterward. Wash your hands thoroughly after replacing RF power devices. Dispose of defective RF power devices only through approved toxic waste facilities.*

If for any reason it should become necessary to change a FET in the field, we strongly recommend following the handling precautions outlined on the next few pages:

BASIC TRANSMITTER MAINTENANCE

Any FET can be damaged by static discharge. It is therefore mandatory that static-free handling techniques as discussed in the foregoing "static 1, equipment 0" tutorial should be routine, and that soldering equipment must be suitable for insulated gate MOSFET work, and must be properly maintained.

- a) Keep FETs in their anti-static containers until ready to install. The module and the technician should both be earthed/grounded. Observe the handling procedures discussed in Part 7 above, including the use of antistatic bench coverings, conductive overshoes, grounded wrist straps, etc.
- b) The soldering iron tip **MUST** be at earth/ground potential at all times, that is, absolutely no AC voltage must be available on the tip. Test with an ohmmeter each time the iron is used; the test must indicate continuity from tip to ground. Special battery operated soldering irons are also available to avoid any chance of AC voltage being present on the tip, but these are not satisfactory for RF FET work as they do not heat to sufficiently high temperatures. Use an accurately controlled temperature regulated low voltage soldering iron, and set it for about 700° to 750°F.

8.1 FET Replacement Hints and Advice:

- a) Back off the FET pressure plate grub screw until the pressure plate under the clamping bridge is able to move freely. Certain IPA boards use different FETs that have a different mounting flange, thus do not require pressure plate nor clamping bridge.
- b) Remove the two screws holding the clamping bridge and FET to the heatsink, then salvage the clamping bridge, pressure plate, screws, and spring lockwashers.
- c) If you are repairing a High Band module with pushpull amplifier(s), make careful note of the location of hairpin inductor L9 in relation to the FET, measuring the spacing of its two legs and its distance from the FET case. (Low Band modules do not use L9). To minimize board damage, use a sharp "screwdriver" tip on the soldering iron, and carefully help it along with a solder pick tool, working it under one tab first, then once that tab is free and FET mounting screws have been removed, the FET can be rocked gently, allowing other tabs to be easily unsoldered in turn. The defective FET can now be lifted out. Remove excess solder with "no clean" fluxed copper braid wick.
- d) Clean the FET heatsink area thoroughly with alcohol (**CAUTION:- ALCOHOL VAPOUR IS TOXIC**), and inspect to ensure that there are no defects nor debris present and that all old thermal compound has been completely removed. The board solder areas should be lightly and uniformly pre-tinned.
- e) Apply only enough heatsink thermal compound (supplied with the transmitter) to the new FET base and to the heatsink, that will result in a thin uniform coating on the FET base and heatsink. The metal should be faintly visible through the coating on both surfaces. Apply it sparingly; too much compound is every bit as bad for thermal transfer as an insufficient amount would be. To refresh your memory: thermal compound fills the tiny little tool marks left by the milling machine on the heatsink surface, but only enough that no microscopic air spaces remain between FET and heatsink. Heat transfer depends partly on the distance through which the heat must travel from the FET to the heatsink; too much compound effectively adds more distance, which could result in overheating.
- f) Lightly pre-tin and gently bend the FET tabs upward slightly, so that the tabs and the circuit board do not prevent the FET from making proper thermal contact with the heatsink.
- g) Install the pressure plate and the clamping bridge over the new FET. **Install the pressure plate so that the raised marks left by its grub screw are facing AWAY from the FET ceramic case, otherwise the case could crack.** Be sure that screw holes in the clamping bridge, the FET, and the heatsink are all in line and clear; you will know, because the screws should turn easily while being installed.

BASIC TRANSMITTER MAINTENANCE

8.1 FET Replacement Hints and Advice: (continued).

- g) When all holes are lined up properly, carefully finger-tighten the two screws and spring lockwashers.
- h) Torque the clamping bridge screws evenly to 4.5 inch-pounds. This amount is recommended by the FET manufacturer to allow for thermal expansion of the device. 4.5 inch-pounds also will avoid the possibility of stripping the threads in the heatsink, or breaking the screws. *Use only the special screwdriver-handle torque wrench and its two keys that came with the transmitter for this work; if that wrench becomes lost or strayed, then obtain one that is intended only for use on delicate electronic or aircraft assemblies. Do not get an automotive torque wrench because it is not capable of being adjusted to small torque values. Do not under any circumstances use a regular Allen key or screwdriver, nor depend on the feeling in your fingertips to judge the applied torque. Your hands may be much stronger than you think.*
- i) Ensure that the pressure plate is centered evenly, between the clamping bridge and the FET, and tighten the grub screw. Torque it also to 4.5 inch-pounds.
- j) Solder each tab to the board in turn, using a solder-pick tool to hold each tab in contact with the board while soldering; apply enough heat to ensure that the pre-tin solder on the boards flows, and apply just enough new solder to give a "butt" free joint. Set the bias resistances at their highest values to get minimum startup current (see step "i" below), and then set the stage bias currents as described in the applicable PA module, Visual Driver, or IPA section of this manual. For a High Band module, position and solder L9 as accurately as possible in its original location.
- k) Use eutectic tin-lead 63/37 solder (preferred, but if 63/37 is not available, 60/40 is acceptable). Current manufacturing process at LARCAN uses AIM™ (American Iron & Metal Company Inc.) 63/37 solder containing a "no clean" flux which becomes inert during soldering, therefore does not require subsequent board cleaning. Other good brands are Kester™ and Ersin Multicore™; equivalent 63/37 or 60/40 "no clean" tin-lead solders also should be available from other vendors. If "no-clean" is unavailable, "RMA" (Resin Mildly Activated) core solder can be used; carefully clean the flux residue from the board with an environmentally friendly board cleaning solvent, applied sparingly.

Most commercially available alcohols are reasonable flux solvents that are harmless to circuit boards, and are CFC free and environment-friendly. Proprietary circuit board cleaning solvents are available that also meet these objectives; check with your local electronics parts dealer.

Inexpensive cotton swabs (available in drug stores or supermarkets) can be used for wiping the solvent over the area to be cleaned, then a stiff bristle brush (an old toothbrush) can be used to scrub if necessary. Use the swabs for mopping up the residue. Clean the board thoroughly, then inspect and clean it again; don't merely rearrange the residue. *Be careful - do not allow solvent to run under power transistors where it can dilute the heatsink compound.*

CAUTION: VAPOURS FROM ALCOHOLS AND OTHER SOLVENTS ARE TOXIC AND FLAMMABLE... DO NOT INHALE! IF YOU ARE A SMOKER, DO NOT SMOKE WHILE USING FLAMMABLE SOLVENTS! USE ALL SOLVENTS ONLY IN A PROPERLY VENTILATED LOCATION!

- l) Finally, if you have not already done so, set the bias potentiometers for the stage to maximum resistance so that when power is applied, the FET will start at its lowest current. Then set the bias as described in the RF Power Amplifier, Visual/Vision Driver, and IPA RF amplifier sections of this manual. We mentioned this procedure during step "j" above as well, because some circumstances may make it simpler to set the bias in a High Band PA before replacing L9. When L9 is in place, each half of the stage will need to be adjusted concurrently with a bias short on the opposite side (to turn off the side not being set), otherwise the DC path through L9 makes the procedure impossible. This is explained in the applicable PA, Visual Driver, or IPA section of the manual.

BASIC TRANSMITTER MAINTENANCE

8.2 Surface-mount Components Hints and Advice:

Failures of small surface mounted resistors on boards where they were companion to other components having leads, were traced to mechanical overstress of their end caps as a result of the soldering procedure to the component. Our manufacturing procedure has since been altered to fix this problem, and despite our embarrassment, we think it is important that you should know about it. For your information:

1. It is critical that surface mount components are soldered onto a clean flat surface. Use a suction device followed by fluxed braid wick material to ensure that all old solder is removed from pads of the board.
2. If this is not possible due to the presence of other components, try to clean at least one of the pads so it is flat (don't solder this end yet), then solder the other (solder-laden) pad FIRST, pressing the component down into the puddle of solder. (Plain wooden toothpicks will serve well as tools to apply pressure to components while soldering them). The remaining flat pad then can be soldered.

To ensure minimum stress on any SM component, always be certain that the component is laying flat in contact with the board before soldering except as above when it is necessary to melt the solder on a pad first, and *never force it unless both ends of the component are free to move.*

3. If all the pads are loaded with solder, it will be necessary to heat all terminals of the component simultaneously. Check with your local electronic parts dealer for special soldering iron tips and/or other attachments (in addition to toothpicks) that will aid in surface-mount work.
4. Always keep the tip of your iron clean and freshly tinned (wetted), for maximum heat transfer.

9. REPLACEMENT PARTS

All component parts in the transmitter are available from:

*LARCAN Inc., 228 Ambassador Drive, Mississauga, Ontario, Canada L5T 2J2;
Phone (905)-564-9222, or FAX (905)-564-9244, during and after normal working hours.*

To expedite delivery of your order, especially if you call after hours and get our answering service, please leave a number where we can return your call, and please identify the parts requested as specifically and completely as possible.

Our Renewal Parts Department may be able to more quickly identify your requirement if the assembly name and number where the part is used, and any applicable revision number for that assembly, are stated in addition to the part's symbol number, description, and its drawing and part number as listed.

Although LARCAN can supply any part when required, in many instances it may be more conveniently obtained from a local source. Part numbers of replaceable components used in LARCAN equipment are almost always the catalog numbers of the various parts manufacturers, with the rare exception of proprietary items such as tightly specified RF power FETs, crystals, or analog 50 μ A meters. If your local dealer or distributor should encounter problems and you require further information, please feel free to call upon anyone in our customer service department at the telephone number given above. We have assumed that reliable dealers of electronic components are located in or near your station market area, and that they maintain adequate stocks of "commodity" items such as resistors and capacitors. We have further assumed that you prefer to obtain most non-proprietary replacement parts from your local dealer, therefore we have listed very few such commodity items here, but we believe the following information might be useful to you during your spares requirements planning:

BASIC TRANSMITTER MAINTENANCE

9. REPLACEMENT PARTS (continued).

Capacitors: Generally, most ceramic or film capacitors are reliable, and "5% spares" (1 spare for each 20 identical parts, and 1 each if less than 20) will be found to be a satisfactory inventory level. This includes ceramic, polystyrene, polyester, polycarbonate, polypropylene, and (usually) solid electrolyte tantalums.

Reliability notwithstanding, it is worth the trouble to know exactly what is inside your replacement capacitors. Use a bridge if available, to measure their capacitance (especially for electrolytics), stray inductance, and ESR (equivalent series resistance). Measure leakage current at rated voltage.

Aluminum electrolytics require further consideration. When you consider aluminum electrolytics, usually you will need to consider their operating temperature as well:

The transmitter cooling system was designed to provide worst-case internal temperatures no higher than 60°C, in all modules of the transmitter. This cooling is based on 45°C maximum ambient air temperature and normal air flow through the intakes of the transmitter cabinet.

Most capacitor vendors state that 60°C or lower operating temperatures can be expected to give service lifetimes for their aluminum electrolytic capacitors of ten years or longer, but as their operating temperature increases to the specified maximum of 85°C, the specified service lifetime decreases to a mere 1000 hours.

You may therefore wish to increase your spares level for aluminum electrolytic capacitors if site ambient temperatures are consistently higher than 40°C, because if cooling air flow becomes restricted due to filter saturation, it is entirely possible for on-board temperatures to reach or exceed 85°C. This is why your maintenance program MUST include the regular inspection and replacement of filter media.

Resistors: Experience has shown that a spares stock to the 5% spares level (1 spare for each 20 of the same thing, and 1 of each when less than 20) for each value and size of resistor, is usually sufficient.

Incidentally, when a molded carbon composition resistor (as specified on LARCAN drawings 3R152, 3R77, 3R78, or 3R79) such as those made by Ohmite™ or Allen-Bradley™, is used in an RF circuit, it is not necessarily good practice to make substitution without knowing exactly what the replacement resistor is; in the past, certain makes of FILM resistors have been touted as replacements for molded composition, but unless the resistors are specifically made to be non-inductive, they may be unsuitable because some film resistors are laser-trimmed on a lathe to final value. The resulting helix has significant inductance which can make the resistor unsatisfactory for use in VHF circuits.

It is worth the trouble to know exactly what is inside your replacement components. Use an RF bridge if available, to measure any stray inductance and/or capacitance associated with your replacement resistors.

Spare Parts: The list on the following pages began as computer output listings "STS10B, STS50B, etc." from our database used to compile the parts list data for each Section of the manual, and the computer has classified recommended spare parts and suggested their quantities, by part number. Because the manual is written to apply to the entire low powered basic series of transmitters, we have made a composite suggested spares list by simply combining the computer's Low Band and High Band recommendations.

Because we believe that you are smarter than our computer, we suggest that the parts lists in each Section booklet comprising the manual should be thoroughly and rigorously scrutinized, with the intention of taking your specific local conditions, and your usual dealers or suppliers inventories and order turnaround times into account, before commitment to a sizable inventory of replacement parts.

BASIC TRANSMITTER MAINTENANCE

10. SPARE PARTS RECOMMENDATIONS:

Although it is our sincere hope that they will never be found necessary, it is recommended that a minimum spares stock of the following items be kept on hand.

The STS50B recommendation which follows is for a minimum parts inventory, mostly semiconductors, for a 50 W transmitter built to operate from 105-120 VAC, 1 ϕ , 50/60 Hz, in the frequency ranges encompassing Band I (Low Band channels 2 thru 6) and Band III (High Band channels 7 thru 13). The 10 watt unit uses the same parts as the 50 watt, so the list also applies to the TTS10B and TRS10B models, except for the AC fuse. In the list, the AC fuse for the 50W is marked with a † and the AC fuse for the 10W with a ‡.

The STS50BG1 High Band suggested spares list has one part specific to High Band that naturally does not appear in the STS50BG2 (chans 2-4) or in the STS50BG3 (chans 5&6) Low Band lists, so we have marked that specific part in our composite list with "" for identification. If your transmitter is High Band (channels 7-13), you may wish to stock all the parts listed; if you have a Low Band unit, simply leave out the "" part. You may also wish to add more items to the list. Page 10 is available for you to do this.

Recommended quantities for fuses are based on actual usage, but you may find it more economical to purchase them in standard boxes of quantity 5 per value, and replenish when the quantity on hand is equal to the quantity on the list.

LARCAN INC.
Parts List

Level	Parent No.	Description	Quantity
0	40D2168	10 VHF AMPLIFIER COMPOSITE LIST - SUGGESTED SPARES	1 EA
<hr/>			
Symbol	Part No.	Description	Quantity
	1N4001	DIODE 1A 50V	2 EA
	1N4148	DIODE SWITCHING	2 EA
	1N5357B	DIODE ZENER 20V 5W	1 EA
	312 007	FUSE 7A 250V <FAST> for RF amplifier	2 EA
	DS2E-SL2-DC12V	RELAY 2 FORM C LATCHING 12VDC	1 EA
	DS2E-S-DC12V	RELAY 2 FORM C MOMENTARY 12VDC	1 EA
	HP5082-2800	DIODE SCHOTTKY see ECG503 or 1N5711	2 EA
	ILQ1	IC OPTO ISOLATOR	1 EA
	LM358N	IC OP AMP DUAL	2 EA
	MC1455P	IC TIMER see 555	1 EA
	MC48B3	FAN, 48 VDC ROTRON	1 EA
	MC7812CT	IC +12 VOLT REG	1 EA
	MC7824CT	IC +24 VOLT REG	1 EA
	MDL-3	FUSE 3A 250V GLASS <SLOW>	1 EA
	MDL 1/4	FUSE 1/4A 250V GLASS <SLOW> for control ps	1 EA
	MHW6185	IC RF AMP	1 EA
	MPS8598	TRANSISTOR PNP GEN PURP	2 EA
	MSC154K	THERMISTOR	2 EA
	MWA330	IC RF AMP in HB preamplifier only	1 EA
	RXE090	PROTECTOR RAYCHEM (control board fuse)	1 EA
	SRF3943-2	TRANSISTOR N-ch DUAL RF POWER FET	1 EA

VHF POWER AMPLIFIER & HEATSINK ASSEMBLY

1. RF Power Amplifier & Heatsink Assembly 30C1899G1 - G2 - G3: (continued).

Most LARCAN exciters produce their best linearity at or near their maximum rated output levels, and often the overall system gain is sufficient to result in overdrive of later stages of the transmitter. The transmitter or translator lineup may therefore include an in-line attenuator between the exciter and the preamplifier, to prevent overdrive from certain models of exciter-modulator.

This is especially true for the 10 watt system, because in our basic transmitter family a 10 watt amplifier is simply a lightly driven 50 watt amplifier, and a 50 watt amplifier is likewise a lightly driven 250 watt output stage running without its driver/IPA. (Our 250 watt transmitter lineup needs an additional IPA to get enough drive to the identical final stage that is used in the 50 watt and 10 watt lineups).

2. RF Preamplifier 10A1453G5 (Low Band) and 10A1453G4 (High Band): Figures 2 and 6.

This preamplifier design originally appeared in the aural/sound section of a dual RF chain transmitter which operates two single RF chains in quadrature and therefore requires phase and gain control of the input to each chain. The same unpopulated circuit board is used for the present application, therefore has the pads and holes for the components which performed the adjustment of RF gain and phase in the parallel systems. In a single chain transmitter such as the present one under discussion, there is no requirement for control of RF phase nor consequently its components; they are therefore removed and wire jumpers substituted.

In the Low Band preamp, the 50 Ω input cable is matched by C5, which uses the inductance of the traces on the PC board to form a low pass matching network, and fed to amplifier U2 whose output connects through a cable to the PA. U2 is a linear amplifier designed originally for use as a wideband cable system trunk amplifier. Cable amplifiers are nominally 75 ohms in and out, but the MHW6185 is capable of a good match with 50 ohm source and load. C12 and the lead inductance of a CA2885 when used as U2, perform output matching to 50 Ω . C12 is not present in a board using an MHW6185 for U2. The gain of U2 is spec'd as 18 dB, and allowing a few dB of losses, the gain of the Low Band preamp is 14 to 16 dB.

RF power FETs operated in High Band amplifiers exhibit about 6 dB less gain than they do in Low Band, so an additional amplifier is necessary to make up the difference. The High Band preamplifier therefore consists of two stages.

In the High Band preamp, the input is matched by C5 and the PC trace inductance which together forms a low pass matching network, and the signal is fed to an additional preamplifier stage U4, whose output appears as the input of U2, which in turn feeds the board output cable. The specified gain of type MWA330 in the U4 position is 6 dB, and a type MHW6185 or CA2885 (U2) is 18 dB. A few dB of losses exist on the board, so the effective gain of the High Band preamp board 10A1453G4 is about 20 to 22 dB.

High Band preamps 10A1453G1 used in higher powered externally diplexed transmitter aural service, have a type MWA130 instead of an MWA330 for U4. Specified gain of an MWA130 is about 12 dB, but we don't recommend substitution of U4 in any internally diplexed system due to overall linearity and intermod requirements which are much more stringent in the internally diplexed case. This is because the 30 dB (or thereabouts) of aural to colour subcarrier isolation normally provided by the diplexer is not there, and it simply means that internally diplexed system intermod numbers have to be much better.

At the output of U2, a match to 50 Ω is provided by C12 and the device lead inductance, which together create a low pass matching network in boards where a type CA2885 cable amplifier is used; conversely a type MHW6185 device characteristics give it a wideband match to 50 Ω therefore no special output matching is necessary, and C12 is not present.

U3 is a voltage regulator providing +24 V to the preamplifier stage(s).

