

AMPLIFIER CONTROLLER BOARD REV.5

CONTENTS

1	INTRODUCTION	1
2	GENERAL OPERATIONS	2
2.1	CONNECTOR AND SIGNAL DEFINITIONS.....	2
2.1.1	J1 BDM (Background Debug Mode) Connection.....	2
2.1.2	J2 Remote RS232 Connection.....	2
2.1.3	J3 Front Panel LCD and Touchpad.....	2
2.1.4	E20, E22 +50 Volt DC Power Supply.....	2
2.1.5	J5 +50 Volt DC Power Supply Sensing (External).....	2
2.1.6	J6 Remote Interface	2
2.1.7	J7 – Not implemented.....	3
2.1.8	J8 Fan Interface.....	3
2.1.9	J9 External Controls.....	3
2.1.10	J10 AGC Control	3
2.1.11	J11 Not implemented.....	3
2.1.12	J12 Forward RF Sample.....	3
2.1.13	J13 Reflected RF Sample	3
2.1.14	J14 Front Panel LCD Power	3
2.1.15	U25 RJ45 Ethernet Interface	3
2.2	JUMPER OPTIONS	4
2.2.1	Jumper E1–Serial Receive Data Select.....	4
2.2.2	Jumper E2–Remote Control Reset	4
2.2.3	Jumper E3–Spare Line Configuration	4
2.2.4	Jumper E4–External or Internal Power Supply Current Sensing	4
2.2.5	Jumper E5–Front Panel ON/OFF Control Switch (System/Manual)	4
2.2.6	Jumper E6– Fan DC Power Select	4
2.2.7	Jumper E7–Manual Remote ON/OFF Control	5
2.2.8	Jumper E8–Power Supply Fan Interlock Bypass.....	5
2.2.9	Jumper E9–Forward RF Detector Color Burst Trap.....	5
2.2.10	Jumper E10–Forward RF Detector Sound Carrier Trap / DVB Filter.....	5
2.2.11	Jumper E11–Forward RF Detector Final Gain Control	5
2.2.12	Jumper E12– Reflected RF Detector Color Burst Trap	5
2.2.13	Jumper E13–Reflected RF Detector Sound Carrier Trap / DVB Filter	5
2.2.14	Jumper E14–Reflected RF Detector Final Gain Control.....	6
2.2.15	Jumper E15–Remote Manual Vswr Reset	6
2.2.16	Jumper E16–AGC Disable Control	6
2.2.17	Jumper E17–VSWR Disable Control	6
2.2.18	Jumper E23– P/S ON Status Polarity	6
2.2.19	Jumper E24– P/S ON Command Polarity.....	6
2.3	RF DETECTOR OPERATION	7
2.4	AGC, VSWR AND CUTBACK OPERATION	7
2.5	INTERLOCKS	8
2.5.1	Hard Interlocks	8
2.5.2	Soft Interlocks	9
2.6	EXTERNAL SIGNALS AND REMOTE CONTROL	9
2.6.1	External #1 Interlock	10
2.6.2	Remote Interface (Individual).....	10
2.6.3	Serial RS232 Interface	10
2.6.4	Serial Ethernet Interface.....	10
2.6.5	External DC Power Supply.....	10
3	SETUP PROCEDURES.....	11
3.1	RF DETECTOR	11
3.1.1	Test Equipment Required.....	11

AMPLIFIER CONTROLLER BOARD REV.5

3.1.2	<i>Jumper Installation</i>	11
3.1.3	<i>Verify OpAmp Offsets</i>	12
3.1.4	<i>Verify Output Power Level</i>	12
3.2	CUTBACK PROTECTION.....	13
3.3	VSWR PROTECTION.....	13
3.4	POWER SUPPLY VOLTAGE AND CURRENT CALIBRATION.....	14
4	REMOTE CONTROL CONNECTIONS MXI TRANSMITTER.....	15
4.1	STATUS OUTPUTS	15
4.2	TELEMETRY OUTPUTS	15
4.3	REMOTE CONTROLS.....	16
4.3.1	<i>RC_TX_On Remote Transmitter ON Control</i>	17
4.3.2	<i>RC_TX_Off Remote Transmitter OFF Control</i>	17
4.3.3	<i>RC_RESET Remote RESET Control</i>	18
4.4	EXT1 SECONDARY EXTERNAL #1 INTERLOCK	18
5	CIRCUIT DESCRIPTIONS	19
5.1	MC68HC9S08 MICROPROCESSOR	19
5.2	POWER SUPPLY VOLTAGE AND CURRENT MONITORING.....	21
5.3	ON/OFF RELAY K1	21
5.4	AGC, CUTBACK AND VSWR.....	22
5.5	RF DETECTOR	23
5.5.1	<i>Circuit Description</i>	23
5.6	J12 CHANNEL – VISUAL FORWARD	23
5.7	J13 CHANNEL – REFLECTED	24
FIGURES		
FIGURE 1	COMB SUBMENU SCREEN.....	7
FIGURE 2	STATUS OUTPUTS.....	15
FIGURE 3	TX_OFF, RESET, AND VOR REMOTE CONTROLS.....	16
FIGURE 4	TX_ON REMOTE CONTROL	16
FIGURE 5	MXI CONTROLLER BOARD ASSEMBLY DIAGRAM 31C1897A1	26
FIGURE 6	MXI CONTROLLER BOARD SCHEMATIC 31C1897S1 SHT1.....	27
FIGURE 7	MXI CONTROLLER BOARD SCHEMATIC 31C1897S2 SHT2.....	28
FIGURE 8	MXI CONTROLLER BOARD SCHEMATIC 31C1897S3 SHT3.....	29
FIGURE 9	MXI CONTROLLER BOARD SCHEMATIC 31C1897S4 SHT4.....	30
FIGURE 10	MXI CONTROLLER BOARD SCHEMATIC 31C1897S5 SHT5.....	31

AMPLIFIER CONTROLLER BOARD REV.5

1 INTRODUCTION

This manual describes revision 5.0 or higher of the circuit board.

The MXi amplifier control board (Assembly 31C1897) is a single-circuit assembly that provides all of the amplifier control functions required for the MXi series of transmitters on a single circuit board. This board can be configured for a number of different transmitter types, power levels, transmission standards and options.

The board implements controls/status/telemetries for remote control through a rear panel connector that will interface to a typical remote control system (such as Moseley or Gentner), when used in an MXi802 or MXi1002 the controls are disabled. An RS232 serial port is also provided to allow the operator to communicate with the main controller located inside the power supply chassis. The MXi control board has RF detectors for forward and reflected power and all the circuitry to support AGC/VSWR/Cutback functions.

The MXi board has a BDM (Background Debug Mode) connector that allows an external computer or laptop to download the software program into the CPU chip. The CPU chip holds the program in its internal Flash memory and so there is no external chip or device that need be replaced to change/upgrade the software.

The concept of this design places all of the control and monitoring functions in one place and therefore eases the setup and maintenance functions on this series of transmitters.

2 GENERAL OPERATIONS

2.1 CONNECTOR AND SIGNAL DEFINITIONS

The connectors on the MXi control board are all shown in Figure 8, which is sheet #3 of the Schematic. The individual signals that are associated with each pin of the connector are also given. A brief description of each of the connectors on the board follows.

2.1.1 J1 BDM (Background Debug Mode) Connection

This is used by the software developer to debug the software programmed into the HCS08 CPU.

The software program is also downloaded into the HCS08 CPU via this connector.

The operator has no real use for this connector since it requires a special interface board.

2.1.2 J2 Remote RS232 Connection

This connector would normally have a nine-pin ribbon cable attached to route the serial signals to the rear panel nine-pin D-shell connector. Although J2 has 10 pins, only the first nine are actually used with pin 10 being left open. A typical three-wire serial port (TxD, RxD and Ground) is implemented on this connector to allow interface to an external laptop or PC. When used in an MXi802 or Mxi1002 this connection is used to communicate with the main controller located inside the power supply chassis.

2.1.3 J3 Front Panel LCD and Touchpad

This uses a ten-wire ribbon cable to send and receive serial data from the Front Panel LCD/Touchpad assembly. This connection is a typical three-wire serial port (TxD, RxD and Ground) that communicates with the LCD/Touchpad.

For an MXi802 and MXi1002 this connection is not used; the touchscreen is located in the power supply chassis.

2.1.4 E20, E22 +50 Volt DC Power Supply

On previous revisions of the circuit board this connector was designated as J4. At revision 4 of the circuit board the J4 connector was replaced with two threaded swaged spacers to allow for higher current handling capabilities. These two connections are used for the +50VDC power that is supplied to the RF amplifier. The +50V source is fed into E20, run through a current sensor on the MXi board and then fed back out E22 to the RF Amplifier. This is the manner in which the current that the +50V power supply is measured. The voltage telemetry sample from the +50V power is also taken from this connector. When an internal power supply without its own current metering is being used, this connector is functional.

For an MXi802 and MXi1002 this connection is not used; current metering is done in the power supply chassis.

2.1.5 J5 +50 Volt DC Power Supply Sensing (External)

This uses a six-pin connector that has all the interface connections for the +50V power supply. Included is an ON command, P/S OK status and a ground reference from the power supply. In the case where an external power supply is being used with its own current metering, the +50V sample and the current telemetry is fed into this connector.

The last signal on this connector is a +12V power supply input that is used to power the MXi amplifier controller board itself. The ground reference is shared with that of the +50V power supply.

2.1.6 J6 Remote Interface

This uses a 15-wire ribbon cable to send status/telemetry and receive commands from the rear panel 15-pin D-shell connector. Although J6 has 16 pins, only the first fifteen are actually used with pin 16 being left open. In addition to the remote signals, there is a single set of contacts made available as an external interlock. This can

AMPLIFIER CONTROLLER BOARD REV.5

connect to an external device or be used as a simple remote ON/OFF. When this board is used in an MXi802 or MXi1002 the controls are disabled but the status and telemetries are still available.

2.1.7 J7 – Not implemented

This connector was removed on revision 4 of the circuit board assembly

2.1.8 J8 Fan Interface

This uses a special connector mounted on the bottom of the MXi amplifier controller board to connect to the fan assembly. The fan assembly normally includes up to four fans that are mounted below the MXi amplifier controller board and is inserted from the bottom of the transmitter control chassis. This connector has ON/POWER control for each of the fans along with a ground reference and a rotational status signal that comes from each of the fans.

2.1.9 J9 External Controls

This has a seven-pin connector that is used to input a variety of signals into the MXi amplifier controller. A pair of pins are used for the External interlock that is connected to a terminal block on the rear chassis (this is in parallel with the external interlock on the Remote Controls J6). There is also a thermal interlock that is sent from the RF amplifier.

2.1.10 J10 AGC Control

This is a three-pin connector that sends a DC reference voltage (with ground reference and shield) to the RF preamplifier module. This DC reference is generated by the AGC circuitry on the MXi amplifier controller to control the RF output level of the amplifier.

2.1.11 J11 Not implemented

This connector was removed on revision 4 of the circuit board assembly

2.1.12 J12 Forward RF Sample

This SMA connector receives the forward power sample from the directional coupler mounted at the rear of the heatsink. This is used by the RF detector to monitor the level of the RF forward power.

2.1.13 J13 Reflected RF Sample

This SMA connector receives the reflected power sample from the directional coupler built mounted at the rear of the heatsink. This is used by the RF detector to monitor the level of the RF reflected power.

2.1.14 J14 Front Panel LCD Power

This is a two-pin connector that sends power (+5V and ground) to the Front Panel LCD/Touchpad assembly.

For an MXi802 and MXi1002 this connection is not used; the touchscreen is located in the power supply chassis.

2.1.15 U25 RJ45 Ethernet Interface

This is a DIGI device that converts the serial remote control data from the microprocessor into an Ethernet connection. This is an optional item on the circuit board and may not be installed depending on which model of transmitter has been specified by the customer. When installed, it allows the transmitter to use an Ethernet connection to communicate remote control data with the associated Larcan remote control PC software.

For an MXi802 and MXi1002 this is not installed since the Ethernet connection is available in the main control chassis.

2.2 JUMPER OPTIONS

2.2.1 Jumper E1–Serial Receive Data Select

This jumper determines the source of serial received data into the HCS08 microcontroller. This will determine the source of remote control commands. When placed in the 'RS232' position, the board will respond to remote commands from the RS232 connections at J2. When placed in the 'INET' position, the board will respond to remote commands from the U25 Ethernet connections. When U25 is not installed, this should always be placed in the RS232 position.

For an Mxi802 or Mxi1002, the remote commands are not used at the amplifier level and there should be no jumper placed in E1.

2.2.2 Jumper E2–Remote Control Reset

This jumper allows the operator to use the remote Reset command to effect a reset of the HCS08 microcontroller. This would only be installed if there were a suspicion that the microprocessor is hanging-up and the operator would intend to reset it remotely. This is purely for diagnostic purposes only and should not normally be permanently installed.

2.2.3 Jumper E3–Spare Line Configuration

This jumper allows the signal into the PA0 pin 32 of the HCS08 microcontroller to be configured as either an input or output. This configuration would already have been done in the software at the factory and this jumper setting should not be altered in the field unless directed by LARCAN personnel.

2.2.4 Jumper E4–External or Internal Power Supply Current Sensing

The MXi Amplifier can be configured with a +50VDC power supply that has a built-in current sensing telemetry or, when the power supply lacks this facility, the MXi controller can measure the current from the +50VDC supply using the onboard current sensor. When the power supply has its own current sensing telemetry, jumper E4 would be set to the External position. When the power supply does not have its own current sensing telemetry, jumper E4 would be set to the Internal position allowing the controller's own current sensor to provide the telemetry.

In the configuration where the amplifier uses external power supplies that have their own current sensing, this jumper would be set in the "Ext" position. This jumper is normally set at the factory and should not be altered in the field.

2.2.5 Jumper E5–Front Panel ON/OFF Control Switch (System/Manual)

This jumper controls the function of the front panel ON/OFF switch. When in the Ext position, the ON/OFF command is fed through the HCS08 microcontroller allowing the operator to utilize remote ON and OFF commands. When in the Int position, the ON/OFF directly controls the ON/OFF relay bypassing the microcontroller and disabling its OFF control ability.

2.2.6 Jumper E6– Fan DC Power Select

Facility has been designed into the controller to allow either 48 volt fans or 12 volt fans. When 12 volt fans are installed, a zero ohm resistor R162 would be installed on the board (which routes +12 volts DC) to the fans and jumper E6 is not installed. When 48 volt fans are installed, resistor R162 would not be installed and E6 would have a jumper installed. This jumper will always be set at the factory depending on the type of fans that were installed in the transmitter

CAUTION! *This jumper is set at the factory depending on the type of fans installed. Field replacement of fans should always be of the same type and rating as was originally supplied with the transmitter. At no time should a jumper be installed in E6 if resistor R162 is installed. This would short the +50V to the +12V and cause damage to the circuit board.*

2.2.7 Jumper E7–Manual Remote ON/OFF Control

This jumper would be installed to allow the operator to manually turn the amplifier ON or OFF via a remote command that would directly control the ON/OFF relay and bypass the HCS08 microcontroller. For this mode to work properly, the front panel ON/OFF switch should be left in the OFF position. In normal operation, this jumper is not installed.

2.2.8 Jumper E8–Power Supply Fan Interlock Bypass

On some models of Mxi transmitters, the power supply does not have its' own fan and relies on Fan #4 of the fan array to cool the power supply. The Mxi control board monitors Fan #4 rotational sensor to insure that it is operating. In the event of a failure of Fan #4, the power supply will have no cooling and the control board would normally shut down the transmitter in this condition. In those Mxi models with these power supplies without its' own fan, jumper E8 would not be installed.

Some models of Mxi transmitters have power supplies which have their own internal cooling fan and do not rely on the Fan array for cooling. In these models, the hardware circuit that would shut down the transmitter in the event of a Fan #4 failure in the Fan Array is bypassed by installing jumper E8

This jumper is installed in the factory depending on the type of Power supply delivered with the product. This should not be changed in the field.

2.2.9 Jumper E9–Forward RF Detector Color Burst Trap

When installed, this jumper enables the filter that removes the color burst from the RF signal. This would only be installed on the analog transmitters, as the digital amplifier does not have a color burst.

2.2.10 Jumper E10–Forward RF Detector Sound Carrier Trap / DVB Filter

This three pin header serves a dual purpose dependant on the type of transmitter and broadcast standard.

When the transmitter is used to broadcast an analog signal, a jumper is installed in the upper two pins to enable the filter that removes the sound carrier from the RF signal. This would only be installed on the analog transmitters, as the digital amplifier does not have a sound carrier.

When the transmitter is used to broadcast a digital DVB signal or similar standard with high peak to average ratios, a jumper is installed in the lower two pins (marked as DVB) to enable a filter that removes the high peaks from the detected signal and allow for a measurement of the average power of the RF signal.

For other digital transmitters with lower peak to average ratios (specifically ATSC), there would be no jumper installed in E10

2.2.11 Jumper E11–Forward RF Detector Final Gain Control

This jumper selects either a high or low gain for the final stage of the RF detector of the Forward power. This jumper is set by the factory depending on the output power of the particular amplifier and level that is obtained from the RF coupler. This should not be changed in the field.

2.2.12 Jumper E12– Reflected RF Detector Color Burst Trap

When installed, this jumper enables the filter that removes the color burst from the RF signal. This would only be installed on the analog transmitters, as the digital amplifier does not have a color burst.

2.2.13 Jumper E13–Reflected RF Detector Sound Carrier Trap / DVB Filter

This three pin header serves a dual purpose dependant on the type of transmitter and broadcast standard.

When the transmitter is used to broadcast an analog signal, a jumper is installed in the upper two pins to enable the filter that removes the sound carrier from the RF signal. This would only be installed on the analog transmitters, as the digital amplifier does not have a sound carrier.

AMPLIFIER CONTROLLER BOARD REV.5

When the transmitter is used to broadcast a digital DVB signal or similar standard with high peak to average ratios, a jumper is installed in the lower two pins (marked as DVB) to enable a filter that removes the high peaks from the detected signal and allow for a measurement of the average power of the RF signal.

For other digital transmitters with lower peak to average ratios (specifically ATSC), there would be no jumper installed in E13

2.2.14 Jumper E14–Reflected RF Detector Final Gain Control

This jumper selects either a high or low gain for the final stage of the RF detector of the Reflected power. This jumper is set by the factory depending on the output power of the particular amplifier and level that is obtained from the RF coupler. This should not be changed in the field.

2.2.15 Jumper E15–Remote Manual Vswr Reset

This jumper allows the remote reset command to directly reset the VSWR trip hardware and bypass the normal remote control that depends on the microprocessor to generate the reset. This is really an emergency bypass state in the event that the microprocessor had developed some fault and the operator needs to control the VSWR relay directly. This would be a very rare condition, and thus jumper E15 is not normally installed.

2.2.16 Jumper E16–AGC Disable Control

When installed, this jumper disables the AGC control of the transmitter and its controller. This is normally only used with setting up the maximum input drive level for the amplifier. In normal operation, this jumper should always be removed, since it can allow excessive power to be mistakenly fed through the amplifier.

2.2.17 Jumper E17–VSWR Disable Control

When installed, this jumper disables the VSWR trip interlock of the transmitter and its controller. This is normally only to be used with setting up the VSWR trip level for the amplifier. In normal operation, this jumper should always be removed, since it removes the VSWR protection from the amplifier. In the presence of a VSWR condition, this could result in damage to the amplifier FET devices.

2.2.18 Jumper E23– P/S ON Status Polarity

The Mxi transmitter can be configured with a number of different power supplies depending on the specific power level and application. Some power supplies generate an active OK status signal whereas other power supply units generate an active low signal. To support these different requirements, the rev 5 and higher version of the circuit board has this jumper to select between active high (+12 vdc) or active low (ground) OK status signal. If jumper E23 is placed in the lower two pins marked as 'MW', the OK Status is active low, else if E23 is placed in the upper two pins then it would be an active high OK Status.

This jumper is set in the factory according to the type of power supply installed in the transmitter and should not be changed in the field.

2.2.19 Jumper E24– P/S ON Command Polarity

The Mxi transmitter can be configured with a number of different power supplies depending on the specific power level and application. Some power supplies require an active high signal for their ON control whereas other power supply units require an active low signal. To support these different requirements, the rev 5 and higher version of the circuit board has this jumper to select between active high (+12 vdc) or active low (ground) control signal. If jumper E24 is placed in the lower two pins marked as 'MW', the control is active low control, else if E24 is placed in the upper two pins then it would be active high control.

This jumper is set in the factory according to the type of power supply installed in the transmitter and should not be changed in the field.

AMPLIFIER CONTROLLER BOARD REV.5

2.3 RF DETECTOR OPERATION

The RF Detector circuitry is shown in Figure 9. This circuitry can be used for internally diplexed analog transmitters or for digital transmitters.

RF Power levels are sampled by a directional coupler located on the RF amplifier heatsink and the resulting RF samples are detected and appropriately processed to provide DC outputs corresponding to the amplitude of the desired parameter of the input signal. These DC outputs contribute to the AGC/VSWR supervision of the transmitter and are also processed in analog to digital conversion circuits on the MXi amplifier controller board to provide digital metering.

The RF Detector can have different group assemblies to support the NTSC system, the PAL system and Digital transmission. NTSC and PAL application differ only in their color subcarrier frequency, consequently in a few component values. All group assemblies use the same PC Board and have many jumpers used to change circuit sensitivity, introduce/remove traps for color subcarrier and/or aural intercarrier and change envelope detector characteristics for digital and analog applications.

The schematic included in this publication shows the circuitry for NTSC and Digital transmissions. For PAL systems a separate schematic would be included that is currently not in this publication.

All jumpers are set in the factory and should not be modified in the field unless under direction from LARCAN personnel.

Required signal levels are as follows:

- FWD (overall forward sample) metering requires 20dBm sync peak signal for full scale (100% rated power).
- RFL (overall reflected sample) metering requires 10dBm sync peak signal for full scale (10% rated power).

The forward RF detector can be configured for a number of different signal types and power levels, these would normally be preset at the factory at the time of transmitter configuration.

Two almost identical detector circuits reside on a single board for visual forward and reflected metering. Detection sensitivity of the circuit dedicated to reflected visual power is approximately 10dB greater than for the visual forward RF detector circuit. The reflected port reading is combined visual and aural power.

2.4 AGC, VSWR AND CUTBACK OPERATION

The MXi amplifier control board allows for an automatic gain control to maintain the transmitter's power at a predefined level. The operator must have first calibrated the RF detector to produce 4.0VDC at the desired 100% power level of the transmitter. The exciter/modulator must then be set up to produce a drive level sufficient to allow 110% power with no AGC controls applied. These operations are described in Section 3.

The AGC system generates a desired reference voltage that is set by the operator through the LCD touchpad. To set the AGC, the operator calls up the Comb submenu from the Main LCD menu. He would then either press the AGC+ button to increase the power level or the AGC- button to decrease the power level. This sets the reference voltage for the AGC circuitry. If there is very low RF power, check that the RF status on the third line is lit. If it is not, then the operator has shut down the RF. Pressing the RF ON menu button restores RF power. The Amps submenu screen is shown below.

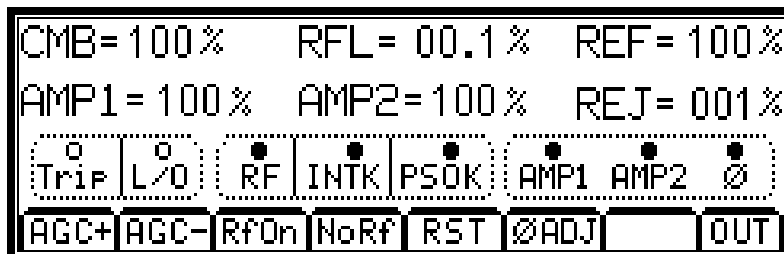

Figure 1 COMB Submenu Screen

AMPLIFIER CONTROLLER BOARD REV.5

The AGC circuit then compares this reference voltage to the actual voltage that is produced from the forward power RF detector. If there is a difference, this is amplified by a high gain OpAmp and this error voltage is fed out to connector J10. An external cable connects J10 to the attenuator on the RF preamp mounted on the heatsink. This will lower the drive to the amplifiers until the transmitter power level agrees with the AGC reference voltage.

Note the AGC voltage from the LCD, if it is near to a value of 0 (i.e., under 0.1V), then there is no AGC action left and the power cannot be raised any further. If the amplifier power is under 100%, then check the RFL power level and CUTBACK voltage to verify that the amplifier is not reducing power to protect from a VSWR condition.

The cutback circuit checks the level of reflected power as displayed on the LCD screen above [RFL=00.1%]. If this reflected power is greater than 1%, the cutback circuit automatically reduces the amplifier forward power to protect the devices. This indicates a mild VSWR condition such as may be caused by an icy antenna. The cutback function is a safety protection and is therefore permanently in circuit and cannot (or should not) be disabled. If the VSWR condition worsens such that reflected power exceeds 10% of forward power, the MXi shuts the transmitter down.

The MXi has built-in VSWR protection to prevent damage to the amplifier from excessive power being reflected back from the output system. This VSWR protection becomes operational when reflected power exceeds 10% of forward power. The system shuts down the amplifier for a few seconds and then tries to restart again. This is done to check if the VSWR was a temporary condition that could have been caused by a lightning strike nearby. The LCD shows the TRIP status light on the third row of the LCD to indicate that a VSWR trip had occurred. If the condition persists such that three VSWR trips occur within 1 minute, the system completely shuts down. The LCD will then illuminate the L/O (Lockout) status light on the LCD to show that a Lockout has occurred.

2.5 INTERLOCKS

Interlocks on the MXi amplifier can be divided into two different types: hard interlocks that shut down the amplifier without any CPU intervention and soft interlocks that are generated by the CPU chip in response to abnormal system parameters.

2.5.1 Hard Interlocks

There are hardware interlocks that directly affect the ON/OFF relay K1 by removing the +12V arming voltage on its coil and preventing it from turning on. There are four of these interlocks as follows:

2.5.1.1. *Amplifier Thermal*

Heatsink thermal opens if heatsink temperature is too high. Dry Contact across Connector J9 pins 5 and 6.

2.5.1.2. *External #1*

Interlock supplied for customer use such as RF system interlock or RF Load.

Dry Contact across Connector J9 pins 1 and 2.

Parallel contact provided across J6 pins 14 and 15, only one of J6 or J9 is required.

If not used, then this contact should be shorted out externally.

2.5.1.3. *VSWR Relay K2*

Contact from VSWR Trip relay K2 pins 11 and 13.

Contact will be closed (OK) if there is no VSWR condition.

Contact will open whenever a VSWR is detected.

Note: Jumper E17 disables this interlock, this is for setup only.

AMPLIFIER CONTROLLER BOARD REV.5

2.5.2 Soft Interlocks

There are parameters that the CPU monitors and if they indicate an error condition, the CPU will issue an OFF command to the ON/OFF relay and set the appropriate error flag. **Note:** if the Local or Remote ON/OFF commands are jumpered to the Override state, the CPU will be unable to shut off the amplifier via K2.

For this reason it is recommended that the ON/OFF controls are left jumpered in the normal positions unless an emergency condition exists. The software interlock parameters are as follows:

2.5.2.1. Power Supply OK

+50V Power Supply is indicating an error, the +12V signal at J5 pin 5 means OK state.

2.5.2.2. Power Supply Voltage

+50V telemetry shows a voltage over +52VDC, Telemetry at J5 pin 6.

2.5.2.3. Power Supply Current

Power Supply Current exceeding the max rating, value depends on MXi model.

For the internal power supply, the telemetry is found at U7 pin 7.

For an external power supply, the telemetry is found at J5 pin 5.

2.5.2.4. Amp Temperature

If the amplifier heatsink is configured with a thermistor. This is optional.

When the heatsink temperature rises too high, the CPU cuts back output power.

This is not a true interlock since the Thermal interlock is used to shut off the transmitter.

This power cutback tries to keep the heatsink from reaching shutoff temperature.

2.5.2.5. Power Supply Fan Failure

For models of transmitters that do not have a power supply with its' own internal cooling fan, the power supply depends on Fan #4 of the Fan Array for cooling. This fan is monitored for its' rotational status. If this fan has failed then the transmitter will shut down in order to protect the power supply.

When the transmitter is fitted with a power supply that has its' own internal cooling fan, then the interlock for Fan #4 will be bypassed by installing Jumper E8.

Caution: This jumper is installed at the factory and should not be altered in the field. Doing so could cause damage to the power supply unit in the event of a failure of Fan #4.

2.5.2.6. Amplifier Fan Failure

The four fans are monitored for their rotational status.

When one or more fans show a failure, the CPU cuts back output power.

This is not a true interlock, as the Thermal interlock is used to shut off the transmitter.

This power cutback tries to keep the heatsink from reaching shutoff temperature.

2.6 EXTERNAL SIGNALS AND REMOTE CONTROL

There are a number of signals that are connected externally at the back panel of the MXi transmitter chassis. These can be classified as either interlocks, remote controls, external power supplies or transmitter switching.

AMPLIFIER CONTROLLER BOARD REV.5

2.6.1 External #1 Interlock

The interlock that is available on the rear panel is the External #1. This is a single dry contact that is provided to shut down the RF amplifier in the case of some external problems (such as a bad RF load). It has two possible connection points that are logically in parallel so that only one needs to be connected. One point is from pins 1 and 2 of J9 on the MXi board. This connector is normally wired to a two-pin terminal block TB1 located on the back panel. This would be the most accessible and likely connection point.

The second parallel connection is from pins 14 and 15 of J6 on the MXi board which is assigned for Remote Controls. This 16-pin connector would usually have a 15-wire ribbon cable attached that would route the signals from the first 15 pins of J6 to a 15-pin D-shell connector on the rear panel.

2.6.2 Remote Interface (Individual)

Connector J6 provides for individual lines of control/status/telemetry that would normally be connected to an external vendor remote control system (such as Moseley or Gentner). This 16-pin connector would usually have a 15-wire ribbon cable attached that would route the signals from the first 15 pins of J6 to a 15-pin D-shell connector on the rear panel. The details of the signals on this connector are given in Section 4. For on MXi802 the controls are disabled but the status and telemetries are still active.

2.6.3 Serial RS232 Interface

Connector J2 provides a standard three-wire serial interface (TxD, RxD and Ground) that is used for communicating with the main TX controller located in the power supply chassis. The user could also use this port to connect to an external computer or laptop serial port. The MXi sends a serial stream out this serial port that reports all of the operating parameters of the transmitter. It can also receive serial commands from an appropriate computer program or the main TX controller.

2.6.4 Serial Ethernet Interface

Device U25 provides a standard RJ45 connection that is used for communicating via to an external computer. The MXi sends a stream out this port that reports all of the operating parameters of the transmitter. It can also receive commands from an appropriate computer program.

2.6.5 External DC Power Supply

Higher power MXi transmitters such as the MXi802 and MXi1002 require that the DC power supply for the amplifier be located external to the amplifier chassis. Connector J5 receives the interface signals for this external supply. These include a +12V input that provides power to the MXi control board itself, a reference ground, a sample of the +50VDC that is used to power the amplifier, and current telemetry sample and a control output from the MXi board used to turn on the supply.

The actual connection is made via a power connector at the rear panel and is wired to connector J5. The actual connection that supplies the amplifier(s) is wired directly from the rear panel to the amplifier and not through the MXi control board.

3 SETUP PROCEDURES

The following sections detail the various set up procedures for the MXi transmitter system. These procedures should only be done by qualified personnel. If the calibrations and setups are done improperly, it can result in the transmitter being prone to damage.

The transmitter is normally set up in the factory for the particular operating power required when first installed. Set up procedures would only be required if certain elements of the MXi transmitter had to be replaced or repaired that would have affected the calibrations. An example of this would be the MXi amplifier controller board itself, the output RF couplers, the RF cables or the +50V power supply.

If the output power is being changed, then some setup and calibration would be needed since the transmitter would be set up for the previous RF power level. **Caution:** do not increase the power output of the MXi transmitter beyond the original factory set level without first consulting LARCAN field service.

3.1 RF DETECTOR

The RF detector is normally calibrated at the factory or by LARCAN field personnel and should not require onsite re-adjustments except in the following circumstances.

- The desired output power level of the transmitter is to be changed from the factory setting for a full 100% power reading. Note that the operator should not just increase and readjust power beyond the recommended rating of the transmitter without prior approval from LARCAN technical services.
- A replacement MXi amplifier control board or directional coupler has been installed in the transmitter.

This procedure assumes that the RF detector is being set-up with the transmitter connected to an RF modulator input and output load (or antenna) that is the actual configuration it is intended to operate with.

3.1.1 Test Equipment Required

- a) An RF power meter such as the HP 436A or similar. For analog transmitters, a BIRD through-line wattmeter is sufficient.
- b) A Spectrum Analyzer, HP 8558B or similar.

If the operator wishes to set up the unit on the bench, then a number of extra pieces of test equipment are necessary.

- An RF generator/modulator that will replicate the desired signal and level
- An analog transmitter would need a video generator such as Tektronix 1900 or similar, and a analog modulator and upconverter
- A digital transmitter would need the *Pulse Modulator* used with the transmitter.
- RF Load rated at the transmitter power and associated cable

3.1.2 Jumper Installation

If the transmitter is not being upgraded from Analog to Digital service (or vice versa), then there should be no need to change the jumpers for the traps or gain. If there is a change, the trap jumpers would need to be modified and perhaps the gain as well.

For Analog service, the color burst and aural carrier traps should normally be installed. The aural carrier traps for E10 and E13 would be placed on the upper two pins

For the forward power sample, this would be jumpers E9 and E10.

For the reflected power sample, this would be jumpers E12 and E13.

For DVB Digital service, jumper E9 and E12 would not be installed, jumpers E10 and E13 would be installed in DVB position.

AMPLIFIER CONTROLLER BOARD REV.5

For ATSC Digital service, the above four jumpers would not be installed.

If the desired transmitter output power is the same as what the transmitter was originally set up for at the factory, there should be no need to change the gain jumpers on the RF detectors.

If a change in power is required or the directional coupler has been changed or the transmitter is being moved between Analog/Digital service, the RF detector should be first set to the lowest possible gain and the jumpers moved to increase the gain.

For the forward power sample, the gain is controlled by jumpers E8 and E11. There are three possible gain settings for these two jumpers

Low Gain: E11=LO

Mid Gain: E11=MID

High Gain: E11= Not Installed

For the reflected power sample, the gain works identically where E14 is the same as E11.

3.1.3 Verify OpAmp Offsets

1. With no RF signal applied, measure the voltage at U5 pin1 and adjust R58 to make this level under 0.1VDC
2. With no RF signal applied, measure the voltage at TP4 and adjust R80 to make this level under 0.1VDC

3.1.4 Verify Output Power Level

1. Attach the RF output power measuring device (Wattmeter or Average Power Meter) to the RF output.
2. Turn down the drive level of the modulator/upconverter before applying the RF input signal.
3. Turn up the drive level until the output power measures the desired reading. Do not use the meter of the transmitter itself to determine output power, since at this point it may be uncalibrated.
4. When increasing the power, it is always instructive to measure the current on the 32VDC supply in case there is a problem with how the output power meter is connected or working. If the supply current is increasing but the output power is not, set the drive to a sufficiently lower level and double check your setup.
5. When the RF output power is at the desired level, do the following checks:
 - a) For the forward power sample, the voltage at U5 pin1 should be within 4.5 to 9.0VDC as a maximum
 - b) If not, then you have either too much power or too high a coupling in the directional coupler.
6. Reverify the output power: if this is correct, a pad can be inserted between the coupler and J12.
7. Adjust potentiometer R48 until the voltage at TP3 is 4.0VDC.
8. To calibrate the reflected power, install jumper E17 that prevents any VSWR trips
9. Remove the RF cable from J12 and attach a -10dB pad, then connect this reduced forward power sample to J13.
10. If the original power sample into J12 required a pad, this must be retained in addition to the -10dB pad.
11. For the reflected power sample, the voltage at TP4 should be within 4.5 to 9.0VDC as a maximum
12. If not, reverify that the output power has not changed in the meantime.
13. Adjust potentiometer R80 until the voltage at TP5 is 4.0VDC.

Note: Make sure that you remove jumper E17 when done, else you will have no VSWR protection!

At this point, the operator should proceed to verify cutback and VSWR trip functions, as described in the next two sections.

AMPLIFIER CONTROLLER BOARD REV.5

3.2 CUTBACK PROTECTION

Before the operator attempts to set up the cutback circuitry, the forward and reflected power levels must be properly set up to calibrated levels as described in Section 3.1.

To set up the cutback level, a power sample must be fed into the reflected power connector of the MXi board that is -16dB down from the forward power sample level. The most convenient way to accomplish this is to take this sample from the RF monitor port on the rear of the transmitter chassis.

1. Disconnect the AGC control connector J10 from the MXi board to remove any possible AGC or cutback action while verifying the Reflected power. If the forward power is greater than 100%, adjust the output level of the upconverter until it is at 100% (+/- 2%).
2. Attach an RF cable from the RF monitor connector at the rear of the MXi control chassis and insert a -16dB pad. This pad can consist of a -10dB and -6dB pad in series. Remove the RF cable from J13 that comes from the output coupler and attach a cable from the -16dB pad off the forward monitor sample.
3. We are assuming that the coupling level from the monitor connector is the same as the coupling level for the forward power RF coupler. To verify this by checking the RFL power level on the LCD, it should read around 2.5% power. If it is off by more than 0.5%, adjust the amount of padding until the RFL power reading is within the range of 2% - 3%. A variable attenuator pad would be ideal for this application.
4. Readjust the upconverter output level so that the forward power reads 110% again.
5. Also disconnect the cable from the monitor port for now.
6. Reconnect the AGC control connector J10 on the MXi board.
7. Reconnect the cable from the monitor port to the reflected power sample at J13.
8. Adjust the potentiometer R105 until the forward power reading is about 96% - 98%, which puts the system just at the edge of cutback.

The setup is now complete, remove the monitor cable from J13 and attach the output coupler back to J13.

3.3 VSWR PROTECTION

The VSWR protection does not really need any setup or calibration since it is fixed to trip when the reflected power is -10dB of the forward power level. To verify the VSWR trip function, the following steps must be taken.

To check the VSWR trips, a power sample must be fed into the reflected power connector of the MXi board that is -10dB down from the forward power sample level. The most convenient way to accomplish this is to take this sample from the RF monitor port on the rear of the transmitter chassis.

1. Disconnect the AGC control connector J10 from the MXi board to remove any possible AGC or cutback action while verifying the Reflected power. If the forward power is greater than 100%, adjust the output level of the upconverter until it is at 100% (+/- 2%).
2. Install a jumper in E17 that will prevent any VSWR trips.
3. Attach an RF cable from the RF monitor connector at the rear of the MXi control chassis and insert a -10dB pad. Remove the RF cable from J13 that comes from the output coupler and attach a cable from the -16dB pad off the forward monitor sample. We are assuming that the coupling level from the monitor connector is the same as the coupling level for the forward power RF coupler. To verify this by checking the RFL power level on the LCD, it should read over 10.1% power but less than 11% power. Note that a minimum of 10.1% power is needed to insure a VSWR trip. If the RFL power is under 10.1%, decrease the amount of padding until the RFL power reading is within the range. If the RFL power is too high (over 11%), increase the amount of padding until it is in the range. A variable attenuator pad would be ideal for this application.
4. Readjust the upconverter output level so that the forward power reads 110% again.
5. Also disconnect the cable from the monitor port for now.
6. Reconnect the AGC control connector J10 on the MXi board.

AMPLIFIER CONTROLLER BOARD REV.5

7. Reconnect the cable from the monitor port to the reflected power sample at J13.
8. Remove the jumper from E17 and the transmitter should trip three times and lock out on the fourth trip.
9. The setup is now complete: remove the monitor cable from J13 and attach the output coupler back to J13.
10. Clear the VSWR lockout and trip condition by either pressing the front panel reset button or issuing a remote reset command.

3.4 POWER SUPPLY VOLTAGE AND CURRENT CALIBRATION

To set up the power supply voltage and current reading, the operator must view the readings on the P/S submenu on LCD display.

1. To set up the voltage reading, turn on the transmitter and verify that the power supply is indeed running.
2. With a voltmeter, measure the voltage on the power supply directly.
3. Adjust potentiometer R14 on the MXi amplifier control board until the displayed voltage equals that being measure by the voltmeter.
4. To set up the current reading, the power supply should be ON as in the above paragraph and enough RF drive (at least 50%) should be applied to get a reasonable current level for calibration.
5. With a clamp on Ammeter, measure the current on the main feed coming from the power supply.
6. Adjust potentiometer R15 until the displayed current agrees with that measured on the clamp on meter.

If an external power supply is used that has its own current telemetry sensing, it may have its own setup as well. The current reading on the LCD will still be affected by R15 but the external supply may require its own calibration, if the level it sends to the MXi is too low or high. A good level would be in the range of 2-4 volts for full scale current.

4 REMOTE CONTROL CONNECTIONS MXi TRANSMITTER

On the rear of the transmitter Chassis, the remote control connections are available on a 15-pin male D-shell connector J6. This includes all of the remote controls, status and telemetries available to the operator.

These remote signals are routed from the MXi Control board via a 15-wire ribbon cable from connector J6 of the MXi Control board. The signals designations for each pin of J6 can be viewed on sheet 3 of the schematic in Figure 8. The actual circuitry that drives these signals is spread out on all five sheets of the schematic.

When the MXi amplifier controller is used in an MXi802 or MXi1002 the remote controls are disabled but the telemetries and status are still present.

4.1 STATUS OUTPUTS

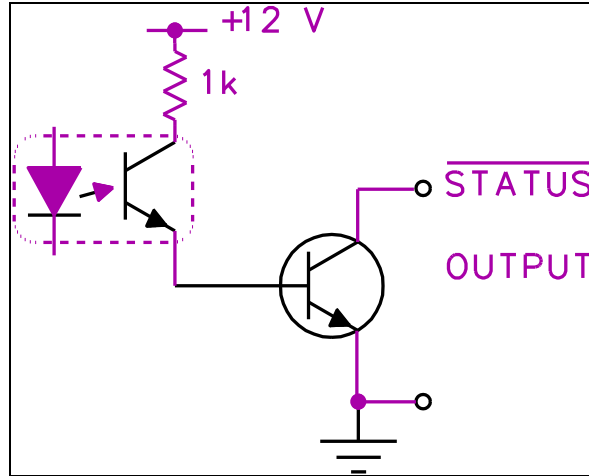

Figure 2 Status Outputs

These are current sinking open collector outputs, out of quad pack MPQ2222 (2N2222A) NPN transistors driven by opto-isolator devices. The available output sink current is dependent on the gain of the NPN and the opto-isolator transfer ratio. Generally, one can expect at least 100mA of sinking current for each output listed here. Because these are open collector, they can be used in special applications, such as on-site warning signal activation if desired, but they are limited in external circuit voltage to maximum 60VDC. Each status (in parentheses) indicates what it means when in its active low condition.

The MXi provides three remote control outputs that represent the current operating state of the switching system via the Digital Output Board

TX D-Connector	PC Board Connector	Designation	Description
Remote Control			
Pin 10	J6 Pin 4	RS_Remote	Transmitter is in Remote Mode
Pin 3	J6 Pin 5	RS_TXOn	Transmitter is turned ON
Pin 11	J6 Pin 6	RS_Error	Transmitter has an error
Pin 12	J6 Pin 8	Ground	Ground Reference

4.2 TELEMETRY OUTPUTS

These are buffered OpAmp outputs, out of quad pack LM324 operational amplifiers. The available output voltage is limited to the range of 0 – 5VDC. The OpAmp can reliably source around 5mA of current and so a relatively high impedance input of at least 2K ohms should be used. Each telemetry has a description to indicate what parameter it is measuring.

The MXi provides four remote telemetry outputs that represent the current operating levels of the MXi transmitter.

AMPLIFIER CONTROLLER BOARD REV.5

TX D-Connector	PC Board Connector	Designation	Description
Remote Controls			
Pin 5	J6 Pin 9	RT_FWD	Forward RF power level
Pin 13	J6 Pin 10	RT_RFL	Reflected RF power level
Pin 15	J6 Pin 12	RT_AGC	AGC voltage (1/2 scale)
Pin 7	J6 Pin 13	RT_CUTB	Cutback voltage (1/2 scale)
Pin 12	J6 Pin 8	Ground	Ground Reference

4.3 REMOTE CONTROLS

The Transmitter MODE must be in REMOTE for any of these remote controls to be operational. The transmitter is placed in the REMOTE mode via the touch LCD menu options. The main LCD screen has a status light to show if the REMOTE MODE is active.

To place the transmitter into REMOTE MODE, the operator must enter the REMCTL submenu on the LCD and enable the REMOTE MODE.

The MXi provides 4 remote control inputs that effectively replicate its own front panel mode control buttons. The VOR (Video Operated Relay) input is not available from the front panel since it is a special type of input that only makes sense as a remote input.

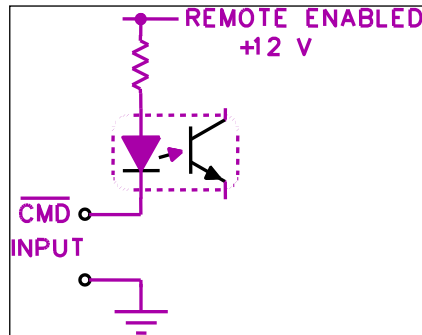

Figure 3 TX_OFF, RESET, and VOR Remote Controls

The TX_OFF , RESET and VOR remote controls are active low, opto-isolated inputs configured as shown, all of which require a GROUND for assertion and the activator to be able to sink 15mA or more for at least 200 milliseconds to accomplish reliable keying. Each of these is current-limited by an individual resistor.

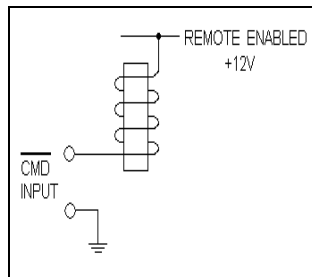

Figure 4 TX_ON Remote Control

The TX_ON remote control is an active low input configured to drive a relay coil off +12V supply. It requires a GROUND for assertion and the activator to be able to sink 100 mA or more for at least 200 milliseconds to accomplish reliable keying.

AMPLIFIER CONTROLLER BOARD REV.5

TX D-Connector	PC Board Connector	Designation	Description
Remote Control			
Pin 1	J6 Pin 1	RC_TX_On	Turns Transmitter ON
Pin 9	J6 Pin 2	RC_TX_Off	Turns Transmitter OFF
Pin 2	J6 Pin 3	RC_Reset	Resets VSWR Trip
Pin 12	J6 Pin 8	Ground	Ground Reference
Pin 15	J6 Pin 14	EXT1+	Secondary Ext1 Intk
Pin 8	J6 Pin 15	EXT1-	Secondary Ext1 Intk

4.3.1 RC_TX_On Remote Transmitter ON Control

The MXi controller has the facility to force the ON/OFF function to follow the front panel ON button. Jumper E5 is a two-position jumper that can be placed in the EXT or INT position (these are silk screened on the PC board). When in the INT position and the front panel button is the ON position, this will force the transmitter to the ON state regardless of the remote or CPU controls. If the front panel button is the OFF position, then the remote ON command will function normally. When jumper E5 is in the EXT position (normal state), then the remote ON command will function normally as well.

A second jumper E7 (Manual Control) also affects the remote ON commands. When installed, this jumper effectively bypasses the CPU and the REMOTE MODE. The transmitter will turn ON whenever there is a low signal applied to the RC_TX_On command input. When this signal is removed, the transmitter turns OFF. This jumper is really a Bypass of the CPU's remote control function and is only meant for emergency purposes. In normal operation, jumper E7 would not be installed. Also note that if jumper E5 (mentioned above) is in INT and the front panel ON button is in the ON position, the remote control input will not be able to turn OFF the transmitter, since it is being held on by the front panel pushbutton.

The following description assumes that jumper E5 is in the EXT position and jumper E7 is not installed.

An active low signal applied to the RC_TX_On command input causes the CPU to read this active state and if the transmitter is in REMOTE mode, then the CPU will issue an ON command to the ON relay K1.

Note that this changes the transmitter's state to ON (when in REMOTE) such that after any subsequent power outage, the MXi transmitter will return to its previous state.

If the operator changes the transmitter's MODE from REMOTE to LOCAL, the ON/OFF state of the transmitter will be controlled by the position of the front panel ON/OFF button.

If the operator changes the transmitter's MODE from LOCAL to REMOTE, the ON/OFF state of the transmitter will revert to the previous state when REMOTE MODE was active.

4.3.2 RC_TX_Off Remote Transmitter OFF Control

The following description assumes that jumper E5 is in the EXT position and jumper E7 is not installed.

An active low signal applied to the RC_TX_Off command input causes the CPU to read this active state and if the transmitter is in REMOTE mode, the CPU removes the ON command from the ON relay K1.

Note that this changes the transmitters state to OFF (when in REMOTE) such that after any subsequent power outage, the MXi transmitter will return to its previous state.

If the operator changes the transmitter's MODE from REMOTE to LOCAL, the ON/OFF state of the transmitter will be controlled by the position of the front panel ON/OFF button.

If the operator changes the transmitter's MODE from LOCAL to REMOTE, the ON/OFF state of the transmitter will revert to the previous state when REMOTE MODE was active.

AMPLIFIER CONTROLLER BOARD REV.5

4.3.3 RC_RESET Remote RESET Control

The remote reset command can have four different possible operations depending on which jumpers are selected in the MXi board.

If both jumpers E15 and E2 are removed (this is the normal mode), the reset command is fed only to the CPU chip, which then issues a VSWR reset, only if the MXi system is in Remote Mode.

If jumper E15 is installed but E2 is removed, the reset command is manually routed to the VSWR relay reset coil and effectively bypasses the CPU chip. In this configuration, a remote reset command clears the VSWR relay and does not depend on the MXi being in Remote Mode.

If jumper E15 is out but E2 is installed, the remote reset command first causes a reset of the CPU chip itself and, if the MXi system is in Remote Mode, the CPU will itself then issue a VSWR reset command.

If both jumper E15 and E2 are installed, the remote reset command causes a reset of the CPU chip itself and will be manually routed to the VSWR relay reset coil bypassing the CPU chip.

4.4 EXT1 SECONDARY EXTERNAL #1 INTERLOCK

The remote connector also has a pair of contacts that replicate a parallel set of contacts for the EXT1 interlocks at TB1 on the rear panel. This is not really a remote control, but it could be used as a simple ON/OFF by supplying a set of controlling contacts across EXT1+ and EXT1-. There is no real polarity required and the + and - designations are just to differentiate the two pins. The other set of contacts on TB1 should be left unconnected if this is being used.

5 CIRCUIT DESCRIPTIONS

5.1 MC68HC9S08 MICROPROCESSOR

The Motorola MC68HC9S08GT microprocessor (often referred to as the CPU or HCS08) performs all of the control interface and communications in the MXi transmitter system. It is a 44-pin surface mount PLCC type device that is permanently soldered to the circuit board and is not field serviceable or easily replaced without special surface mount tooling. A brief description of the part is given in this section and a portion of the manufacturer's documentation is given in Appendix A. More detailed information on this part can be obtained from the Motorola web site.

The HCS08 chip used in the MXi can come with up to 128 Kbytes of non-volatile flash memory, which can be erased and reprogrammed to allow updating of software code or system parameters. The MXi code is typically smaller than 8k and so would fit into all models of Flash memory. The HCS08 chip has a dedicated serial input pin designated as the BDM (Background Debug Mode) port that is used to program the internal Flash memory and for debug testing. The MXi is programmed at the factory and it is not expected that reprogramming would need be done in the field, although it is possible to do with the proper software. System parameters and status that need to be retained during power failures (such as the LOG entries) are also stored in the Flash memory.

Most of the external pins on the HCS08 are configured as programmable Input/Output (I/O) ports, where the software program determines whether a certain pin is to be configured as either an input or output. The pins on the HCS08 are grouped together in sets called PORTs. These Ports will have eight pins (or fewer) to support the byte wide data path in the CPU. Port A is used for general system inputs and outputs. Port B is used as an eight-channel A/D converter to measure system telemetry values. Port C is used for general system inputs and outputs. Port D assigns four pins for the synchronous serial port (SPI) with the other four pins used for system inputs. Port E assigns two pins as a serial communications port (SCI), one pin is the external CPU clock and the other two pins used for general system inputs and outputs.

The definition of each Port pin is as follows:

PORT A

PA0	Input or Output	Jumper E3 configures as I/P or O/P
PA1	Input	VSWR Trip Status

PORT B

PB0	Telemetry	Temperature of Heatsink [Optional]
PB1	Telemetry	Power Supply Current
PB2	Telemetry	Power Supply Volts
PB3	Telemetry	Cutback Volts [Scaled at half the actual value]

PORT C

PC0	Input	50V Power Supply OK Status
PC1	Input	Thermal Interlock
PC2	Output	Digi Ethernet Reset Control
PC3	SCI2	Transmit Data Used by Remote Controls
PC4	Output	Remote Status – Error
PC5	SCI2	Receive Data Used by Remote Controls

AMPLIFIER CONTROLLER BOARD REV.5

PORT D

PD0	Telemetry	AGC Volts [Scaled at half the actual value]
PD1	Telemetry	Agc Set Reference Level
PD2	Telemetry	RF Reflected Power [from RF detector]
PD3	Telemetry	RF Forward Power [from RF detector]

PORT E

PE0	SCI1	Transmit Data Used by LCD
PE1	SCI1	Receive Data Used by LCD
PE2	Output	VSWR Reset Control
PE3	Output	Remote Status – Remote Mode
PE4	Input	Fan#1 Status, Active Low
PE5	Input	Fan#2 Status, Active Low
PE6	Input	Fan#3 Status, Active Low
PE7	Input	Fan#4 Status, Active Low

PORT F

PF0	Input	Power Supply (Relay K1) ON Status
PF1	Input	External #1 Interlock
PF4	Output	Agc Reference PWM Dac
PF5	Output	CPU On Control (to Relay)

PORT G

PG0	Input	Remote Control ON Command
PG1	Input	Remote Control OFF Command
PG2	Input	Front Panel ON Command
PG3	Input	Front Panel VSWR RESET Command
PG5	Output	Crystal Input #1
PG6	Output	Crystal Input #2

The HCS08 provides two separate serial interfaces to external components, these are the asynchronous serial communications interface (SCI1 and SCI2). These two SCI ports implement the standard three-wire serial port (Rx Data, Tx Data and Ground) that would interface to a typical computer port. The baud is set at 9600. The baud is derived from the system oscillator clock at 4.9152MHz. This frequency is recommended by the manufacturer to easily obtain the most common bauds.

AMPLIFIER CONTROLLER BOARD REV.5

5.2 POWER SUPPLY VOLTAGE AND CURRENT MONITORING

For the following description, refer to Figure 7 (Sheet #2 of the Schematic) in the upper section of the drawing for the power supply monitoring circuitry. In the case of a MXi802 or MXi1002 the first section describing the on-board current sensor is for reference only since sensing is done in the power supply chassis.

The MXi board has a built-in Hall Effect current sensor that is able to measure the current drawn by the RF amplifier from the +50 volt power supply. The standard MXi low power transmitter would have a 50 amp current sensor. For higher power transmitters, the power supply would be external to the amplifier chassis and is fitted with its own current sensor telemetry that is fed into the MXi board separately and the MXi current sensor would be left unused.

When the internal current sensing is being utilized, the MXi expects the +50V to be applied at connector E20. This voltage is passed through a current monitoring circuit and then fed back out on pin E22 to the RF amplifiers. When current passes through the sensor, then the output voltage would increase. When using U27 as the sensor, jumper E4 must be placed in the INT position. The output of E4 is fed into the positive input of OpAmp U7B with a potentiometer R15 is placed in the feedback path of U7A to allow the current to be calibrated.

When the power supply is external (usual in higher power MXi transmitters), the actual power supply is external to the amplifier chassis and will then do its own current metering. In this configuration, the MXi board would not have its own U27 current sensor installed but would receive this telemetry information from J5 pin 5. Jumper E4 selects between the internal U27 sensing output or an external current sensor. When using the external sensor, jumper E4 must be placed in the EXT position. OpAmp U7A allows for a gain control through potentiometer R15 so that the current reading can be calibrated.

The Power Supply voltage is expected to be +50 volts DC +/- 0.5V and can be fed into the MXi board from one of two points, depending on whether the supply is internal or external to the amplifier chassis.

When the power supply is internal to the MXi amplifier chassis, then the MXi expects the +50V to be applied at connector E20. This voltage is passed through a current monitoring circuit and then fed back out on pin E22 to the RF amplifiers. This configuration is used when the MXi is a lower power transmitter that can accommodate the power supply internally.

When the power supply is external (usual in higher power MXi transmitters), the actual power supply is external to the amplifier chassis and will then do its own current metering. The +50V sample is connected to J5 pin 6 (which is in parallel with E20). Connector E20 is a higher current contact that would allow the current to be passed through the internal current sensor U27. For an external supply these are not required and so both U27 and E20 will most likely not be installed on the board.

5.3 ON/OFF RELAY K1

The ON/OFF relay K1 and associated circuitry is shown in Figure 7. Relay K1 is a two-pole, single-side stable relay that requires a constant voltage applied to its coil to maintain contact closure. The contacts of this relay provide the control signals to activate the +50V power supply and the cooling fans.

There are two elements that determine if power is applied to the coil of K1. One is the +12V arming voltage on the positive side of the coil that comes from the interlock chain. Three interlocks are placed in series with this coil such that all three must be closed in order for K1 to receive its +12V arming voltage. The three interlocks are Thermal, External #1 and VSWR Trip. If any of these interlocks are open, then the relay will not be energized and transmitter amplifier will be shut down.

The second element that determines if power is applied to the coil of K1 is the control signal on the negative side of the coil. This control signal can come from one or more of three sources.

The HCS08 CPU can always activate the coil from its PF5 pin. This pin activates the base of transistor U10B that in turn will energize the coil of K1. The second source is the remote control TX_ON command at connector J6 pin 1. When jumper E7 is installed, the remote control TX_ON command can directly energize the coil of K1. The third source is the front panel ON button. When jumper E5 is in the INT position, the front panel ON button when pressed in will directly energize the coil of K1. For an MXi802 or MXi1002 the front panel ON button is mounted in the power supply chassis, not the amplifier chassis and the remote control TX_ON command is disabled.

AMPLIFIER CONTROLLER BOARD REV.5

When K1 is energized, both poles of the relay will close and cause the transmitter to generate RF power.

One pole of K1 (consisting of pins 4, 6 and 8) will generate the Power Supply ON command and also provide the CPU a status input of whether relay K1 is activated or not. A +12V arming signal is fed into the Common pin of the contact and if the relay is energized, this +12V signal is fed to the Normally Open contact and routed to the +50V power supply. This command causes the power supply to activate and send its +50V to the RF amplifier. The Normally closed contact of this relay contact is fed back to the CPU and is used to monitor if K1 is energized.

The second pole of K1 (consisting of pins 13, 11 and 9) is used to activate the cooling fans and generate a remote 'TX ON' status. A ground arming signal is fed into the Common pin of the contact and if the relay is energized, this ground signal is fed to the gate of Mosfet CR22. This Mosfet is rated at 10 Amps and provides higher current capability to support virtually any fan type. The Normally closed contact of this relay contact is fed to the remote control status output RS_TX_ON at J6 pin 5. When K1 is not energized and the transmitter is OFF, this output will be floating (high if an external pullup is used), when K1 is energized this output would be ground indicating that the transmitter is ON.

5.4 AGC, CUTBACK AND VSWR

Figure 10 shows the circuitry associated with the AGC, cutback and VSWR functions. Each of these is described as follows.

The AGC circuit uses the voltage reference that is set by the HCS08 CPU via a pulse width modulated timer signal that generates a DC reference voltage at the output of OpAmp U22B called 'AGC REF'. This voltage is effectively the desired voltage output that the system wants to see coming from the forward power RF detector. OpAmp U15A compares the reference voltage to the actual voltage from the RF detector and provides an error output voltage when the value of the detected voltage is greater than the desired reference. If the detected voltage is less, then we have lower power than is desired and no AGC action would be needed. The OpAmp 15A has a high value feedback resistor to provide high gain and cause a strong AGC action for relatively small changes in output power.

The output error voltage from U15A is fed through a resistor divider that has jumper E16 in the middle of it. If E16 is installed, this shorts out any error voltage from U15A and disables the AGC action. This jumper should not be normally left installed, it is typically only used during setup operations and should be removed for everyday operations.

If E16 is not installed, the AGC error voltage is fed to the input of buffer OpAmp U15D and then out the MXi amplifier control board to the RF PreAmp attenuator via connector J10. The voltage at the PreAmp reduces the drive level to the RF amplifier and thus reduces the output power.

The AGC error voltage from U15A is divided by two with resistor divider R90/R92 and sent to the inputs of buffer OpAmps U15B and U15C. U15B provides AGC voltage telemetry for the remote control and U15C provides AGC voltage telemetry for the HCS08 CPU.

The Cutback circuitry monitors the level of reflected power and compares it to a preset level. If the reflected power exceeds the reference level then an AGC voltage is produced that reduces the transmitter output power. The purpose for doing this is to protect the Amplifier devices from damage resultant from too much RF power reflecting back from the output system.

The reflected power sample is sent to OpAmp U17C which compares this with the reference level set by potentiometer R15; test point TP6. This reference level is set up by sending -16dB of the transmitter forward power into the reflected port and adjusting R105 until the MXi begins to just start reducing the amplifiers output power.

When the reflected power exceeds the reference level, OpAmp U17C will generate an error voltage that is fed into the AGC output OpAmp U15D via diode CR12. This has the same effect as an AGC reduction.

The Cutback voltage from U17C is divided by two with resistor divider R98/R99 and sent to the inputs of buffer OpAmps U19B and U19A. U19A provides Cutback voltage telemetry for the remote control and U19B provides Cutback voltage telemetry for the HCS08 CPU.

AMPLIFIER CONTROLLER BOARD REV.5

The VSWR trip circuit provides protection to the RF amplifier in the presence of a persistent and high level reflected power condition. The VSWR system is set to trip at a reflected power level of -10dB down from the forward power.

OpAmp U17 compares the reflected power voltage with the forward power voltage. When the RF detector setup is done, the reflected power voltage is set for 4.0V when it is at a level of -10dB lower than the full rated forward power. The forward power voltage is set for 4.0V when it is at the full rated forward power level. When these two voltages are equal, then the reflected power is indeed -10dB under the forward power level.

In the case that the forward power sample has been removed or improperly setup, it is possible for the forward power level to be near 0V or very low. In this condition, any amount of reflected power would cause a VSWR trip which is undesirable and unnecessary. To prevent this event, OpAmp U17A forces a minimum forward power level of about 1.5V into U17D that would require a minimum reflected voltage of 1.5V to cause a VSWR trip. This represents a reflected power level of around -8.5dB instead of -10dB .

When the reflected level exceeds -10dB , set coil of relay K2 is energized, causing a VSWR trip to occur. Relay K2 is a two-coil latched relay where energizing the set coil causes the contacts of K2 to move into the set position and remain there even after the coil is de-energized. Once a VSWR trip has occurred, the relay K2 will remain in the set position until a signal is sent from the HCS08 CPU to the other reset coil that moves the contacts back into the original clear position.

The HCS08 CPU can activate the coil from its PE2 pin. This pin forces the output of NAND gate U18A high which activates the base of transistor U6C that in turn will energize the reset coil of K2.

The VSWR relay has two poles, one for the transmitter interlock and the second for status. The interlock pole is part of the arming interlock chain of the ON/OFF relay K1. If the K2 contact is opened (i.e., there was a VSWR trip), the arming voltage is removed from ON/OFF relay K1 and the transmitter shuts down. Note that jumper E17 is provided to override the VSWR relay trip contacts. This jumper is only for setup purposes and should never be left installed in normal operations.

Note: Leaving the jumper E17 installed will defeat all the VSWR protection and could result in damage to the RF amplifier if a high reflected power condition occurs.

The second pole of K2 lights status LED DS10 when the relay has tripped under VSWR condition. The other side of this pole is fed into the CPU, which uses this to determine if K2 is tripped or not.

5.5 RF DETECTOR

5.5.1 Circuit Description

The board is fitted with two RF detectors, which respond to RF samples fed from RF directional couplers mounted on output combiner of the Amplifier heatsink. Both sections of the board are configured in a similar way.

5.6 J12 CHANNEL – VISUAL FORWARD

The RF sample is applied to input J12 and is terminated by R53 for an impedance of around 50 ohms . CR5 and Q4 form an envelope detector. CR5 is forward biased slightly by R43 and R54 to overcome CR5 conduction threshold voltage, thereby improving detection linearity. Q4 is forward biased by R43 as well, and when RF is applied, Q4 is driven in the direction of turn off during each positive-going half cycle, thus causing its emitter voltage to become more positive and in effect forming a linear envelope detector.

C24 utilizes the lead inductances of CR5 and Q4 to form a Tee network, which provides a matching section that improves the UHF signal transfer between the devices. Q4 and CR5 have similar temperature coefficients and the opposing connection of the two in this back-to-back configuration provides temperature compensation.

Finally, Q4 serves as a low impedance video source. Jumper E9 is used to introduce color subcarrier trap FL1. An alternate trap consisting of C43, C25 and L1 (marked with asterisks) can also provide this function. The alternate trap can also be easily changed in values to provide different frequency traps for other systems (like PAL).

Note: only one of either FL1 or the Inductor/Capacitor traps would be installed but never both.

AMPLIFIER CONTROLLER BOARD REV.5

Transistor Q2 serves as a buffer and Q1 serves as another buffer. Following is filter FL2, which removes the aural carrier. An alternate Inductor/Capacitor trap consisting of L2, C44 and C26 is also provided. Jumper E10 is a three position jumper that can select this filter. The second position of E13 allows a filtering capacitor to be placed in the circuit to eliminate the high peaks in broadcast signals such as DVB which have high Peak to Average ratios.

The inverted and amplified video signal is fed to a peak detector comprised of CR4, C22 and R47 through resistor R42 (1k ohm). R42 will effectively form a RC charging circuit that averages the signal and eliminates any momentary peaks.

Because a single supply op-amp is used at U5, the output seen on U5 pin 1 and TP3 contains a small DC offset which must be minimized because low level signals are near ground/earth potential. With no RF input, this offset voltage is adjusted by potentiometer R58 as near as possible to ground/earth. The setting can be seen when using a DC coupled scope. Adjust R58 to move the DC level toward ground/earth potential; stop turning the potentiometer immediately the DC ceases moving. A residual voltage offset of 20 millivolts can be expected for the LM358 family of op-amps.

The gain of the amplifier stage at U5A can be adjusted by selecting one of the three available feedback resistors R56 (2.7K ohms) or R59 (8.2K ohms) or R146 (7.5K ohms) using jumper E11. When the lowest gain is desired, E11 is placed in the LO position selecting R56 in parallel with R146. When the middle gain is desired, E11 is placed in the MID position selecting R59 in parallel with R146. When the highest gain is desired, E11 is not installed leaving only R146 in the feedback path.

Outputs from unity gain op-amps U13A, U13B, U13C and U13D drive the forward power metering circuits. The output of U13A provides telemetry to the CPU A/D converter input. The output of U13B provides telemetry to the AGC (VSWR) circuitry. The output of U13C provides telemetry to the remote controls and U13D provides telemetry for the optional transmitter switch connections. Bench test calibration consists of adjusting R48 with rated, properly modulated input while observing the voltage at TP3, which should read 4.0 volts DC for full scale calibration.

5.7 J13 CHANNEL – REFLECTED

The RF sample is applied to input J13 and is terminated by R74 for an impedance of around 50 ohms. CR9 and Q6 form an envelope detector. CR9 is forward biased slightly by R67 and R76 to overcome CR9 conduction threshold voltage, thereby improving detection linearity. Q6 is forward biased by R67 as well, and when RF is applied, Q6 is driven in the direction of turn off during each positive-going half cycle, thus causing its emitter voltage to become more positive and in effect forming a linear envelope detector.

C32 utilizes the lead inductances of CR9 and Q6 to form a Tee network, which provides a matching section that improves the UHF signal transfer between the devices. Q4 and CR5 have similar temperature coefficients and the opposing connection of the two in this back-to-back configuration provides temperature compensation.

Finally, Q6 serves as a low impedance video source. Jumper E12 is used to introduce color subcarrier trap FL3. An alternate trap consisting of C33, C45 and L3 (marked with asterisks) can also provide this function. The alternate trap can also be easily changed in values to provide different frequency traps for other systems (like PAL). Note that only one of either FL1 or the Inductor/Capacitor traps would be installed but never both.

Following is filter FL4 which removes the aural carrier. An alternate Inductor/Capacitor trap consisting of L4, C46 and C32 is also provided. Jumper E13 is a three position jumper that can select this filter. The second position of E13 allows a filtering capacitor to be placed in the circuit to eliminate the high peaks in broadcast signals such as DVB which have high Peak to Average ratios.

The inverted and amplified video signal is fed to a peak detector comprised of CR8, C30 and R71 through either resistor R66 (1k ohm) where R66 will effectively form a RC charging circuit that averages the signal and eliminates any momentary peaks.

Because a single supply op-amp is used at U14D, the output seen on TP4 will contain a small DC offset which must be minimized because low level signals are near ground/earth potential. With no RF input, this offset voltage is adjusted by potentiometer R80 as near as possible to ground/earth. The setting can be seen when using a DC-coupled scope. Adjust R80 to move the DC level toward ground/earth potential; stop turning the potentiometer immediately the DC ceases moving. A residual voltage offset of 20 millivolts can be expected for the LM358 family of op-amps.

AMPLIFIER CONTROLLER BOARD REV.5

The gain of the amplifier stage at U14D can be adjusted by selecting one of the three available feedback resistors R79 (6.2K ohms) or R82 (24K ohms) or R148 (20K ohms) using jumper E14. When the lowest gain is desired, E14 is placed in the LO position selecting R79 in parallel with R148. When the middle gain is desired, E14 is placed in the MID position selecting R82 in parallel with R148. When the highest gain is desired, E14 is not installed leaving only R148 in the feedback path.

Outputs from unity gain op-amps U14A, U14B and U14D drive the reflected power metering circuits. The output of U14A provides telemetry to the CPU A/D converter input. The output of U14B provides telemetry to the CUTBACK and VSWR circuitry. The output of U14C provides telemetry to the remote controls. Bench test calibration consists of adjusting R72 with rated, properly modulated input while observing the voltage at TP5, which should read 4.0 volts DC for full scale calibration.

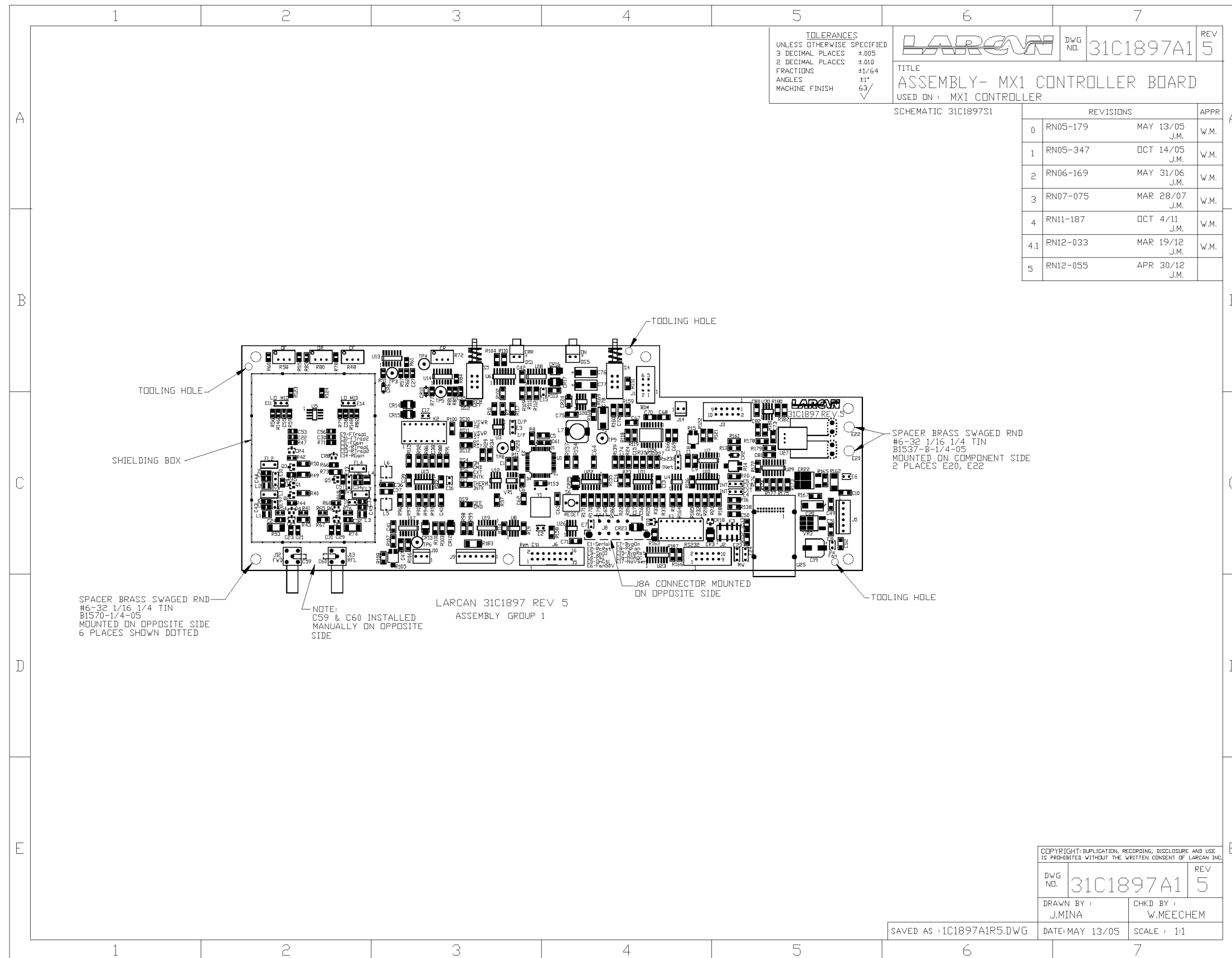
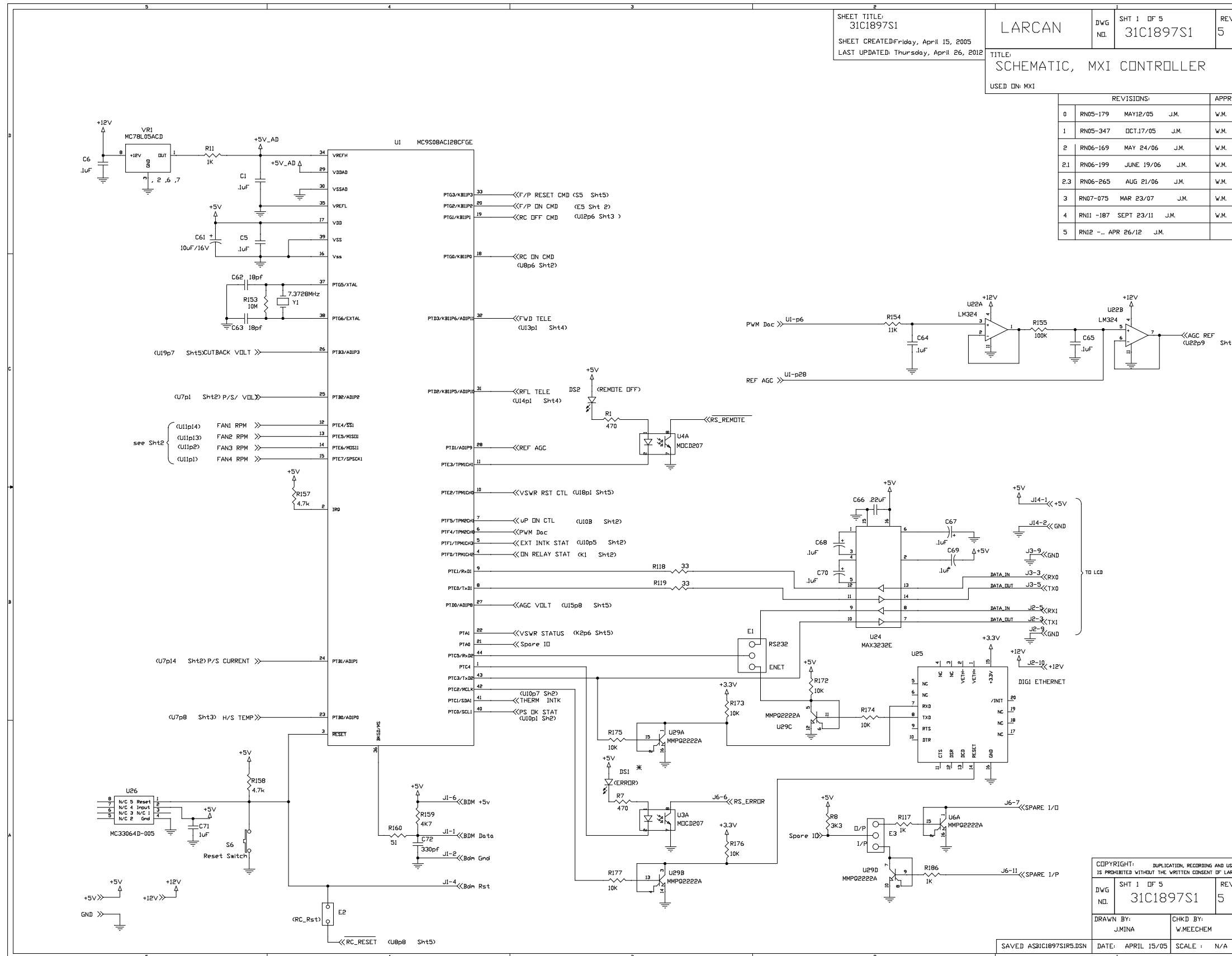

Figure 5 MXi Controller Board Assembly Diagram 31C1897A1



SHEET TITLE:
31C1897S1
SHEET CREATED: Friday, April 15, 2005
LAST UPDATED: Thursday, April 26, 2012

TITLE:
SCHEMATIC, MXI CONTROLLER
USED ON: MXI

LARCAN DWG NO. SHT 1 OF 5 31C1897S1 REV 5

REVISIONS:				APPR
0	RN05-179	MAY12/05	J.M.	W.M.
1	RN05-347	OCT.17/05	J.M.	W.M.
2	RN06-169	MAY 24/06	J.M.	W.M.
2.1	RN06-199	JUNE 19/06	J.M.	W.M.
2.3	RN06-265	AUG 21/06	J.M.	W.M.
3	RN07-075	MAR 23/07	J.M.	W.M.
4	RN11 -187	SEPT 23/11	J.M.	W.M.
5	RN12 -...	APR 26/12	J.M.	

COPYRIGHT: LARCAN INC. REPRODUCTION, REPAIRING AND USE IS PROHIBITED WITHOUT THE WRITTEN CONSENT OF LARCAN INC.

DWG NO.	SHT 1 OF 5 31C1897S1	REV 5
DRAWN BY:	J.MINA	CHKD BY: W.MEECHEM
DATE:	APRIL 15/05	SCALE: N/A

Figure 6 MXi Controller Board Schematic 31C1897S1 sht1

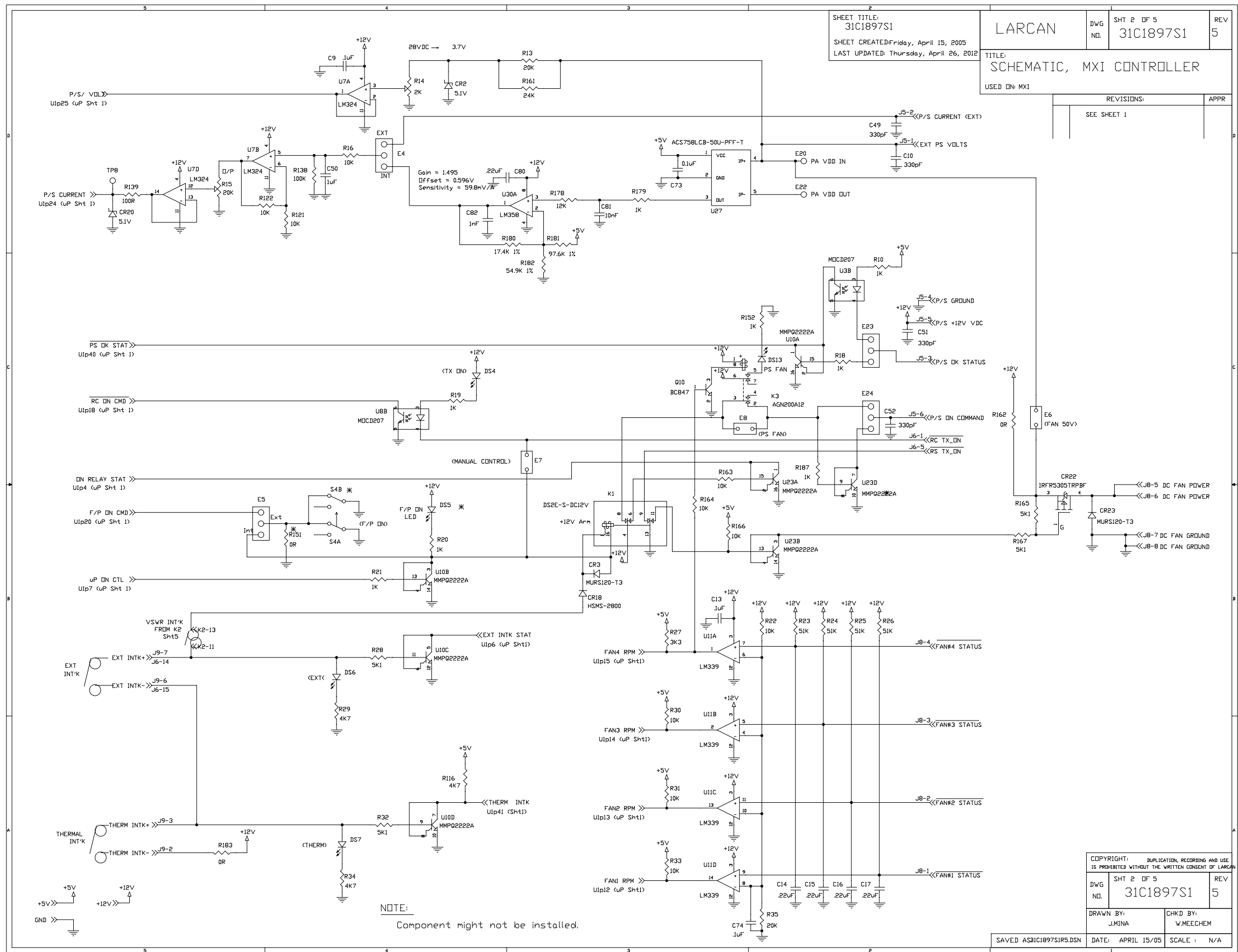

SHEET TITLE:
31C1897S1
SHEET CREATED: Friday, April 15, 2005
LAST UPDATED: Thursday, April 26, 2012

LARCAN	DWG NO.	SHT 2 OF 5 31C1897S1	REV 5
TITLE: SCHEMATIC, MXI CONTROLLER		USED ON: MXI	REVISIONS: SEE SHEET 1
		APPR	

NOTE:
Component might not be installed.

COPYRIGHT: LARCAN INC. DUPLICATION, RECORDING AND USE IS PROHIBITED WITHOUT THE WRITTEN CONSENT OF LARCAN INC.		
DWG NO.	SHT 2 OF 5 31C1897S1	REV 5
DRAWN BY: J.MINA	CHKD BY: W.MEECHEM	
DATE: APRIL 15/05	SCALE: N/A	

Figure 7 MXI Controller Board Schematic 31C1897S2 sht2

SHEET TITLE:
31C1897S1
SHEET CREATED: Friday, April 15, 2005
LAST UPDATED: Thursday, April 26, 2012

LARCAN DWG NO. 31C1897S1 SHT 3 OF 5 REV 5

TITLE:
SCHEMATIC, MXI CONTROLLER

USED ON: MXI	REVISIONS:	APPR:
	SEE SHEET 1	

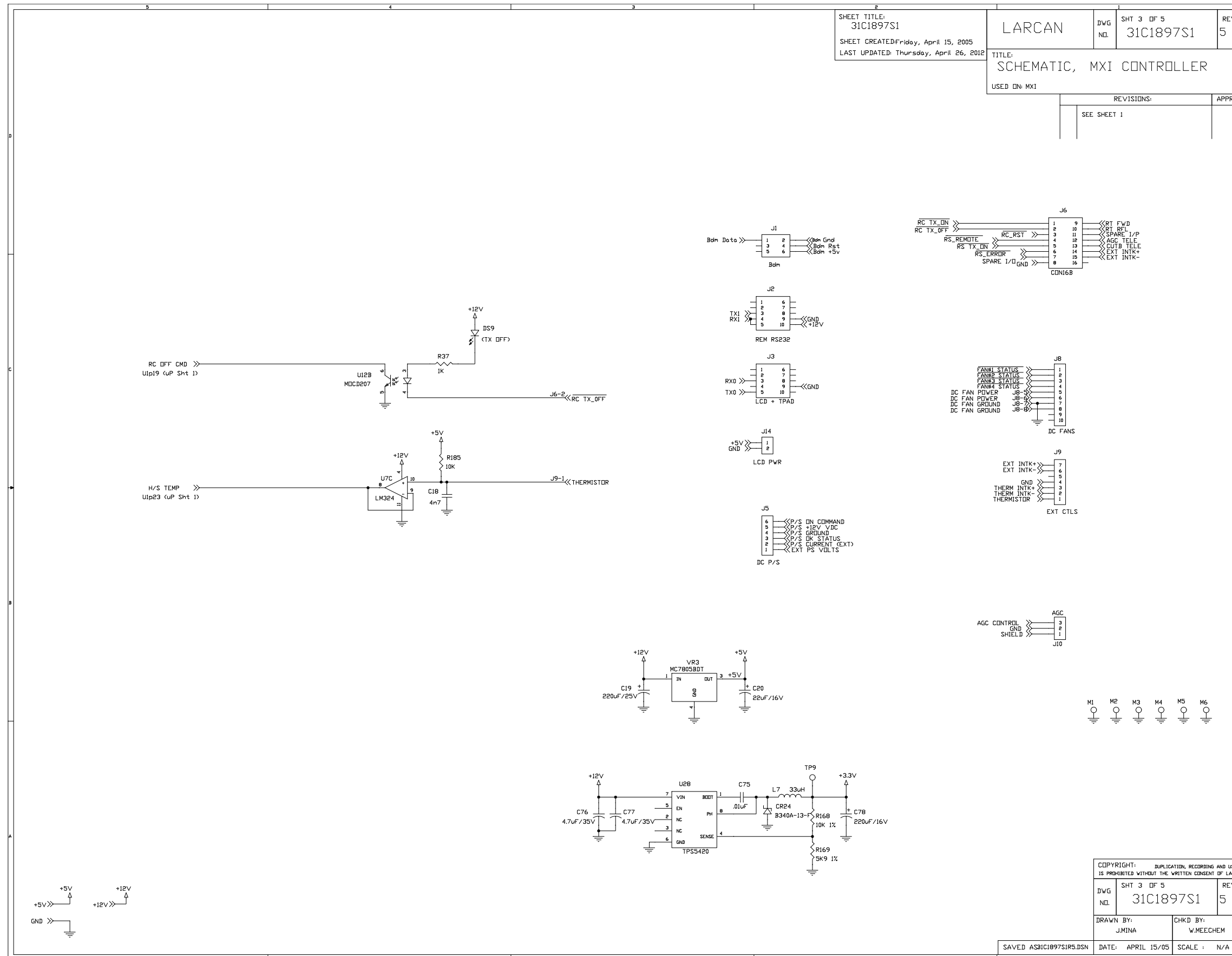

Figure 8 MXi Controller Board Schematic 31C1897S3 sht3

COPYRIGHT: DUPLICATION, RECORDING AND USE IS PROHIBITED WITHOUT THE WRITTEN CONSENT OF LARCAN INC.

DWG NO. 31C1897S1 SHT 3 OF 5 REV 5

DRAWN BY: J.MINA CHKD BY: W.MEECHEM

SAVED AS: 31C1897S1RS.DSN DATE: APRIL 15/05 SCALE: N/A

SHEET TITLE:
31C1897S1
SHEET CREATED: Friday, April 15, 2005
LAST UPDATED: Thursday, April 26, 2012

LARCAN	DWG NO.	SHT 4 OF 5 31C1897S1	REV 5
--------	---------	-------------------------	----------

TITLE:
SCHEMATIC, MXI CONTROLLER
USED ON: MXI

REVISIONS:	APPR
SEE SHEET 1	

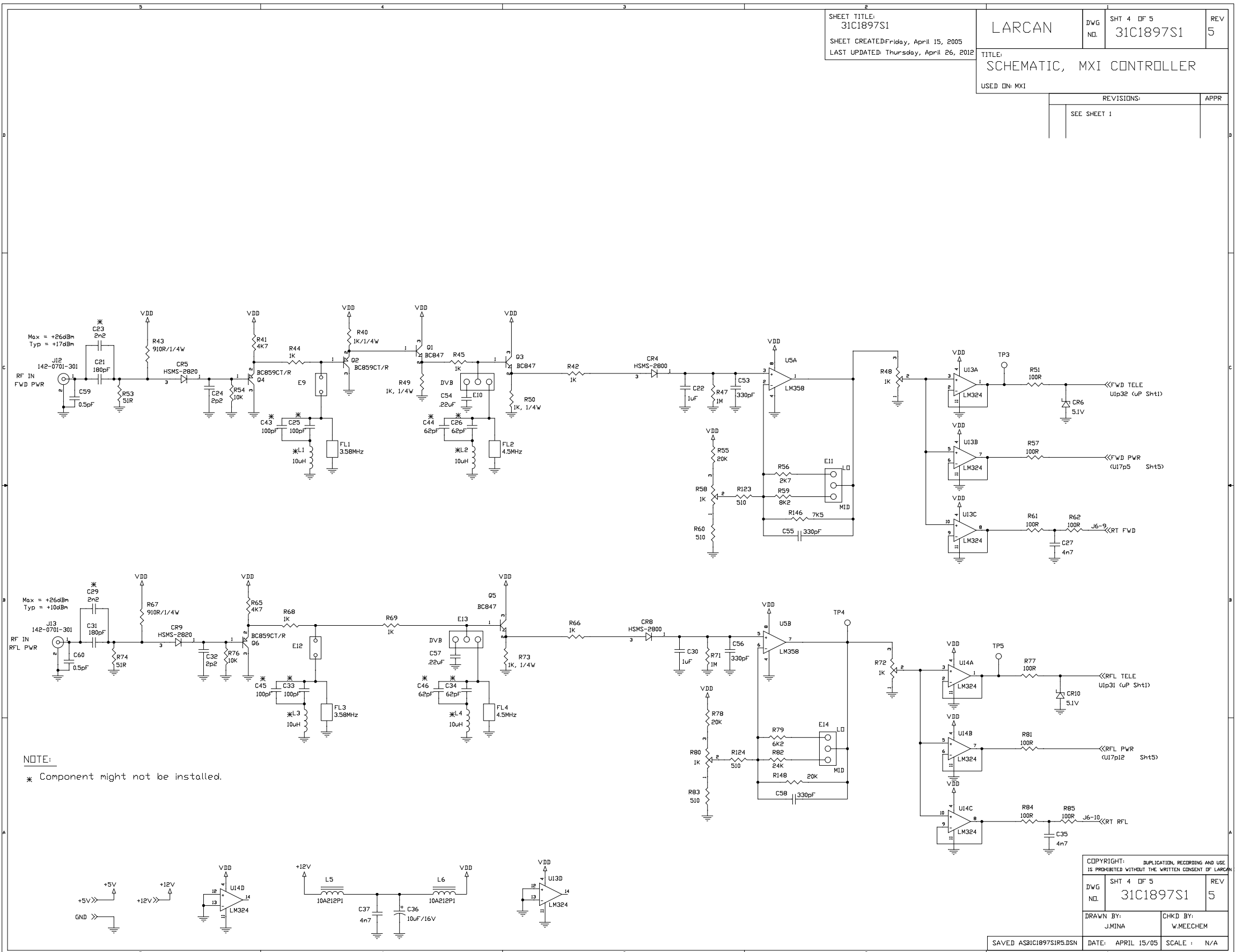

NOTE:
* Component might not be installed.

COPYRIGHT: LARCAN INC. REPLICATION, RECORDING AND USE IS PROHIBITED WITHOUT THE WRITTEN CONSENT OF LARCAN INC.

DWG NO.	SHT 4 OF 5 31C1897S1	REV 5
---------	-------------------------	----------

DRAWN BY: J.MINA
CHKD BY: W.MEECHEM

SAVED AS: 31C1897S1R5.DSN DATE: APRIL 15/05 SCALE: N/A

Figure 9 MXi Controller Board Schematic 31C1897S4 sht4

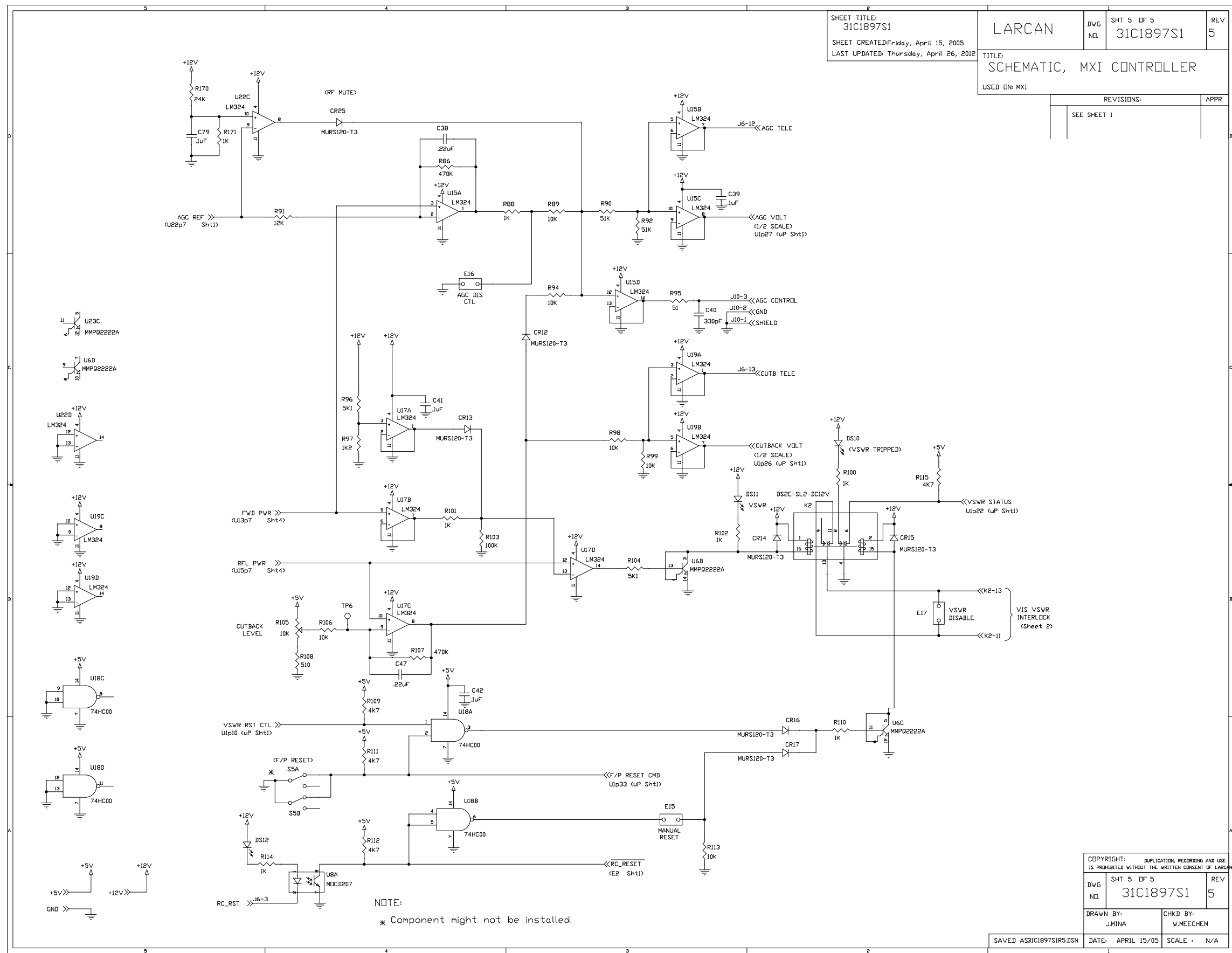

SHEET TITLE:
31C1897S1
SHEET CREATED: Friday, April 15, 2005
LAST UPDATED: Thursday, April 26, 2012

LARCAN		DWG NO.	SHT 5 OF 5 31C1897S1	REV 5
TITLE: SCHEMATIC, MXI CONTROLLER				
USED ON: MXI				
REVISIONS:			APPR	
SEE SHEET 1				

COPYRIGHT: DUPLICATION, RECORDING AND USE IS PROHIBITED WITHOUT THE WRITTEN CONSENT OF LARCAN INC.				
DWG NO.	SHT 5 OF 5 31C1897S1	REV 5		
DRAWN BY:	J.MINA	CHKD BY:	W.MEECHEM	
DATE:	APRIL 15/05	SCALE:	N/A	

Figure 10 MXi Controller Board Schematic 31C1897S5 sht5

