

V1.00.000

09-08-2022

Copyright Information

Copyright © 2022 by LAUNCH TECH CO., LTD. All rights reserved. No part of this publication may be reproduced, stored in a retrieval system, or transmitted in any form or by any means, electronic, mechanical, photocopying and recording or otherwise, without the prior written permission of LAUNCH. The information contained herein is designed only for the use of this unit. LAUNCH is not responsible for any use of this information as applied to other units.

Statement: LAUNCH owns the complete intellectual property rights for the software used by this product. For any reverse engineering or cracking actions against the software, LAUNCH will block the use of this product and reserve the right to pursue their legal liabilities.

Trademark Information

LAUNCH is a registered trademark of LAUNCH TECH CO., LTD. (also called LAUNCH for short) in China and other countries. All other LAUNCH trademarks, service marks, domain names, logos, and company names referred to in this manual are either trademarks, registered trademarks, service marks, domain names, logos, company names of or are otherwise the property of LAUNCH or its affiliates. In countries where any of the LAUNCH trademarks, service marks, domain names, logos and company names are not registered, LAUNCH claims other rights associated with unregistered trademarks, service marks, domain names, logos, and company names. Other products or company names referred to in this manual may be trademarks of their respective owners. You may not use any trademark, service mark, domain name, logo, or company name of LAUNCH or any third party without permission from the owner of the applicable trademark, service mark, domain name, logo, or company name. You may contact LAUNCH by visiting the website at www.cnlaunch.com, or writing to LAUNCH TECH. CO., LTD., Launch Industrial Park, North of Wuhe Avenue, Banxuegang, Bantian, Longgang, Shenzhen, Guangdong, P.R.China, to request written permission to use Materials on this manual for purposes or for all other questions relating to this manual.

SAFETY PRECAUTIONS AND WARNINGS

To prevent personal injury or damage to vehicles and/or the test equipment, please read this user's manual first carefully and observe the following safety precautions at a minimum whenever working on a vehicle:

- There are no user serviceable parts. Have the device serviced by a qualified repair person using only identical replacement parts. This will ensure that the safety of the device is maintained. Disassembling the device will void



the warranty right.

- Caution: This tool contains an internal Lithium Polymer battery. The battery can burst or explode, releasing hazardous chemicals. To reduce the risk of fire or burns, do not disassemble, crush, pierce or dispose of the battery in fire or water.
- This product is not a toy. Do not allow children to play with or near this item.
- Do not expose the device to rain or wet conditions.
- Do not place the device on any unstable surface.
- Never leave the device unattended during charging process. The device must be placed on a non-flammable surface during charging.
- Handle the device with care. If the device is dropped, check for breakage and any other conditions that may affect its operation.
- Do not operate the tool in explosive atmospheres, such as in the presence of flammable liquids, gases, or heavy dust.
- Keep the tool dry, clean, free from oil, water or grease. Use a mild detergent on a clean cloth to clean the outside of the device when necessary.
- People with pacemakers should consult their physician(s) before use. Electromagnetic fields in close proximity to heart pacemaker could cause pacemaker interference or pacemaker failure.
- Always perform automotive testing in a safe environment.
- Do not attempt to operate or observe the tool while driving a vehicle. Operating or observing the tool will cause driver distraction and could cause a fatal accident.
- Wear safety eye protection that meets ANSI standards.
- Keep clothing, hair, hands, tools, test equipment, etc. away from all moving or hot engine parts.
- Operate the vehicle in a well-ventilated work area: Exhaust gases are poisonous.
- Put blocks in front of the drive wheels and never leave the vehicle unattended while running tests.
- Use extreme caution when working around the ignition coil, distributor cap, ignition wires and spark plugs. These components create hazardous voltages when the engine is running.
- Put the transmission in P (for A/T) or N (for M/T) and make sure the parking brake is engaged.
- Keep a fire extinguisher suitable for gasoline/chemical/ electrical fires



nearby.

- Don't connect or disconnect any test equipment while the ignition is on or the engine is running.

FCC Statement

Any changes or modifications not expressly approved by the party responsible for compliance could void the user's authority to operate the equipment.

This device complies with Part 15 of the FCC Rules. Operation is subject to the following two conditions:

- (1) This device may not cause harmful interference, and
- (2) This device must accept any interference received, including interference that may cause undesired operation.

Note: This equipment has been tested and found to comply with the limits for a Class B digital device, pursuant to part 15 of the FCC Rules. These limits are designed to provide reasonable protection against harmful interference in a residential installation. This equipment generates uses and can radiate radio frequency energy and, if not installed and used in accordance with the instructions, may cause harmful interference to radio communications. However, there is no guarantee that interference will not occur in a particular installation. If this equipment does cause harmful interference to radio or television reception, which can be determined by turning the equipment off and on, the user is encouraged to try to correct the interference by one or more of the following measures:

- Reorient or relocate the receiving antenna.
- Increase the separation between the equipment and receiver.
- Connect the equipment into an outlet on a circuit different from that to which the receiver is connected.
- Consult the dealer or an experienced radio/TV technician for help.

Table of Contents

| | |
|--|-----------|
| 1 Introduction | 1 |
| 2 General Information | 3 |
| 2.1 On-Board Diagnostics (OBD) I | 3 |
| 2.2 On-Board Diagnostics (OBD) II | 3 |
| 2.3 Diagnostic Trouble Codes (DTCs)..... | 5 |
| 2.4 Location of the Data Link Connector (DLC)..... | 6 |
| 3 Product Descriptions | 8 |
| 3.1 General Controls | 8 |
| 3.2 Specifications | 9 |
| 3.3 Accessory Included..... | 9 |
| 4 Initial Use | 10 |
| 4.1 Charging & Turning On/Off | 10 |
| 4.1.1 Charging | 10 |
| 4.1.2 Turning On/Off | 10 |
| 4.2 Getting Started | 10 |
| 4.2 Job Menu | 11 |
| 4.3 Settings | 12 |
| 4.3.1 Units of measurement..... | 12 |
| 4.3.2 Automatic detection on connect..... | 12 |
| 4.3.3 Firmware Fix | 12 |
| 4.3.4 Report | 13 |
| 4.3.5 Display/Brightness | 13 |
| 4.3.6 Sound | 13 |
| 4.3.7 Network | 13 |
| 4.3.8 Time Zone | 13 |
| 4.3.9 Language..... | 13 |
| 4.3.10 Region (TPMS)..... | 13 |
| 4.3.11 Workshop information | 13 |
| 4.3.12 Recovery..... | 14 |
| 4.3.13 Clean Up..... | 14 |

| | |
|--|-----------|
| 4.3.14 Screen Capture..... | 14 |
| 4.3.15 Data | 14 |
| 5 TPMS Operations | 16 |
| 5.1 Activate Sensor..... | 18 |
| 5.2 Program Sensor | 22 |
| 5.2.1 Auto create..... | 22 |
| 5.2.2 Manual input | 23 |
| 5.2.3 Copy by Activation | 24 |
| 5.2.4 Copy by OBD..... | 25 |
| 5.3 Learning Service..... | 27 |
| 5.4 Diagnose | 27 |
| 5.5 OE Inquiry..... | 28 |
| 6 OBD II Diagnosis | 31 |
| 6.1 Connection | 31 |
| 6.2 Start Diagnostics | 32 |
| 6.2.1 Read I/M Readiness | 33 |
| 6.2.2 Read Live Data | 34 |
| 6.2.3 Read Freeze Frame..... | 34 |
| 6.2.4 Read Fault Code..... | 34 |
| 6.2.5 Clear Fault Code..... | 34 |
| 6.2.6 Test Results: On-Board Monitoring Test | 34 |
| 6.2.7 Control Operation of On-Board Component/System | 35 |
| 6.2.8 Read Vehicle Information..... | 35 |
| 7 Reset..... | 36 |
| 7.1 Maintenance Light Reset (Oil Reset)..... | 36 |
| 7.2 Electronic Parking Brake Reset (BRAKE RESET) | 37 |
| 7.3 Steering Angle Calibration (SAS RESET) | 37 |
| 7.4 Battery Matching (BAT. RESET)..... | 37 |
| 7.5 Throttle Matching (ELEC. THROTTLE RLRN) | 38 |
| 8 Upgrade | 39 |
| 9 FAQ | 40 |
| Warranty | 41 |

1 Introduction

This tool provides the following functions:

TPMS:

- Trigger the TPMS sensor
- Program the TPMS sensor
- Provide TPMS relearning procedures and sensor OE number lookup

OBD II Diagnosis:

Check for DTCs, isolate the cause of the illuminated Malfunction Indicator Lamp (MIL), check monitor status before emissions certification testing, verify repairs, and perform other services that are emission-related.

Reset:

Offers coding, reset, relearn and more service functions, to help vehicles get back to functional status after repair or replacement.

One-click Update:

Keep the tool updated with the latest available software version online.



Note: This tool may automatically reset while being disturbed by strong static electricity. THIS IS A NORMAL REACTION.

This tool is specially designed to work with all OBD II compliant vehicles, including Controller Area Network (CAN). It is required by EPA that all 1996 and newer vehicles (cars and light trucks) sold in the United States must be OBD II compliant and this includes all American, Asian and European vehicles.

A small number of 1994 and 1995 model year gasoline vehicles are OBD II compliant. To verify if a 1994 or 1995 vehicle is OBD II compliant, check the following:

1. **Vehicle Emissions Control Information (VECI) Label.** It is located under the hood or by the radiator of most vehicles. If the vehicle is OBD II compliant, the label will designate **OBD II Certified**.

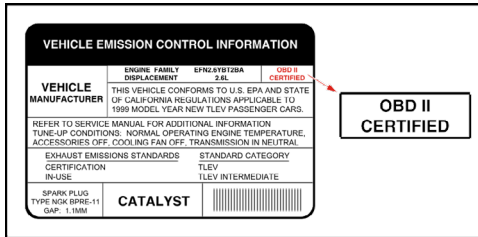

2. Government regulations mandate that all OBD II compliant vehicles **must** have a “common” 16-pin **Data Link Connector (DLC)**.

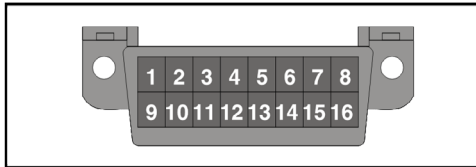

 Note: Some 1994 and 1995 vehicles have 16-pin connectors but are not OBD II compliant. Only those vehicles with a Vehicle Emissions Control Label stating **OBD II Certified** are OBD II compliant.

2 General Information

2.1 On-Board Diagnostics (OBD) I

 Note: With the exception of some 1994 and 1995 vehicles, most vehicles from 1982 to 1995 are equipped with some type of first generation On-Board Diagnostics.

Beginning in 1988, California's Air Resources Board (CARB), and later the Environmental Protection Agency (EPA) required vehicle manufacturers to include a self-diagnostic program in their on-board computers. The program would be capable of identifying emissions-related faults in a system. The first generation of Onboard Diagnostics came to be known as OBD I.

OBD I is a set of self-testing and diagnostic instructions programmed into the vehicle's onboard computer. The programs are specifically designed to detect failures in the sensors, actuators, switches and wiring of the various vehicle emissions-related systems. If the computer detects a failure in any of these components or systems, it lights an indicator on the dashboard to alert the driver. The indicator lights only when an emissions-related problem is detected.

The computer also assigns a numeric code for each specific problem that it detects, and stores these codes in its memory for later retrieval. These codes can be retrieved from the computer's memory with the use of a **Code Reader** or a **Diagnostic Tool**.

2.2 On-Board Diagnostics (OBD) II

As technology evolved and the desire to improve the On-Board Diagnostic system increased, a new generation of On-Board Diagnostic system was developed. This second generation of On-Board Diagnostic regulations is called **OBD II**.

In addition to performing all the functions of the OBD I System, the OBD II System has been enhanced with new Diagnostic Programs. These programs closely monitor the functions of various emissions-related components and systems (as well as other systems) and make this information readily available (with the proper equipment) to the technician for evaluation.

The California Air Resources Board (CARB) conducted studies on OBD I equipped vehicles. The information that was gathered from these studies

showed the following:

- A large number of vehicles had deteriorating or degraded emissions-related components. These components were causing an increase in emissions.
- Because OBD I systems only detect failed components, the degraded components were not setting codes.
- Some emissions problems related to degraded components only occur when the vehicle is being driven under a load. The emission checks being conducted at the time were not performed under simulated driving conditions. As a result, a significant number of vehicles with degraded components were passing Emissions Tests.
- Codes, code definitions, diagnostic connectors, communication protocols and emissions terminology were different for each manufacturer. This caused confusion for the technicians working on different make and model vehicles.

To address the problems made evident by this study, CARB and the EPA passed new laws and standardization requirements. These laws required that vehicle manufacturers to equip their new vehicles with devices capable of meeting all of the new emissions standards and regulations. It was also decided that an enhanced on-board diagnostic system, capable of addressing all of these problems, was needed. This new system is known as **On-Board Diagnostics Generation Two (OBD II/OBD 2)**. The primary objective of the OBD II system is to comply with the latest regulations and emissions standards established by CARB and the EPA.

The Main Objectives of the OBD II System are:

- To detect degraded and/or failed emissions-related components or systems that could cause tailpipe emissions to exceed by 1.5 times the Federal Test Procedure (FTP) standard.
- To expand emissions-related system monitoring. This includes a set of computer run diagnostics called Monitors. Monitors perform diagnostics and testing to verify that all emissions-related components and/or systems are operating correctly and within the manufacturer's specifications.
- To use a standardized Diagnostic Link Connector (DLC) in all vehicles. (Before OBD II, DLCs were of different shapes and sizes.)
- To standardize the code numbers, code definitions and language used to describe faults. (Before OBD II, each vehicle manufacturer used their own code numbers, code definitions and language to describe the same faults.)
- To expand the operation of the Malfunction Indicator Lamp (MIL).

- To standardize communication procedures and protocols between the diagnostic equipment (Diagnostic Tools, Code Readers, etc.) and the vehicle's on-board computer.

2.3 Diagnostic Trouble Codes (DTCs)

OBD II Diagnostic Trouble Codes are codes that are stored by the on-board computer diagnostic system in response to a problem found in the vehicle. These codes identify a particular problem area and are intended to provide you with a guide as to where a fault might be occurring within a vehicle. **DO NOT** replace parts based only on DTCs without first consulting the vehicle's service manual for proper testing procedures for that particular system, circuit or component.

OBD II Diagnostic Trouble Codes consist of a five-digit alphanumeric code.

- The 1st character is a **letter** (B, C, P or U). It identifies the **main system** where the fault occurred (Body, Chassis, Powertrain, or Network).
- The 2nd character is a **numeric digit** (0 thru 3). It identifies the **type** of code (Generic or Manufacturer-Specific).

 Generic DTCs are codes that are used by all vehicle manufacturers. The standards for generic DTCs, as well as their definitions, are set by the Society of Automotive Engineers (SAE).

Manufacturer-Specific DTCs are codes that are controlled by the vehicle manufacturers. The Federal Government does not require vehicle manufacturers to go beyond the standardized generic DTCs in order to comply with the new OBD II emissions standards. However, manufacturers are free to expand beyond the standardized codes to make their systems easier to diagnose.

-
- The 3rd character is a letter or a **numeric digit** (0 thru 9, A thru F). It identifies the specific system or sub-system where the problem is located.
 - The 4th and 5th characters are **letters** or **numeric digits** (0 thru 9, A thru F). They identify the section of the system that is malfunctioning.

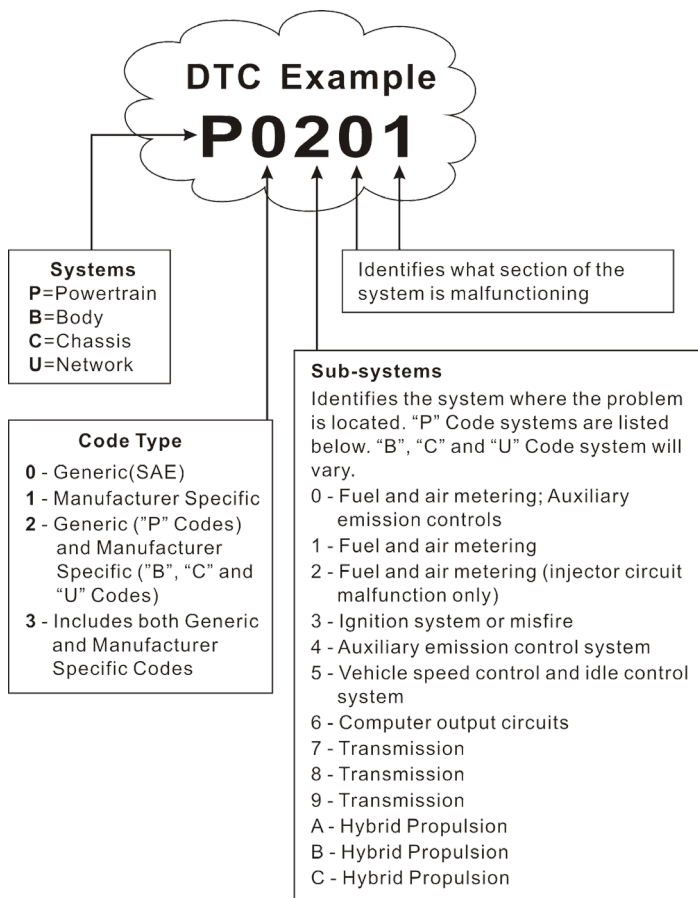

P0201 - Injector circuit malfunction, Cylinder 1

2.4 Location of the Data Link Connector (DLC)

The DLC (Data Link Connector or Diagnostic Link Connector) is typically a 16-pin connector where diagnostic code readers interface with the vehicle's on-board computer. It is usually located 12 inches from the center of the

instrument panel, under or around the driver's side for most vehicles. For some vehicles with special designs, the DLC location may vary.

Refer to the following figure for location.

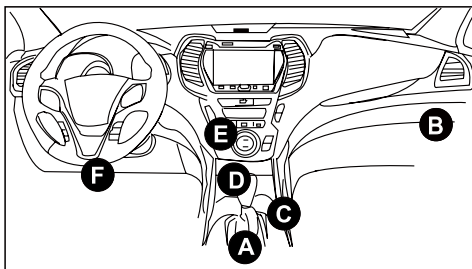

| | |
|---|--|
| A | Opel, Volkswagen, Audi |
| B | Honda |
| C | Volkswagen |
| D | Opel, Volkswagen, Citroen |
| E | Changan |
| F | Hyundai, Daewoo, Kia, Honda, Toyota, Nissan, Mitsubishi, Renault, Opel, BMW, Mercedes-Benz, Mazda, Volkswagen, Audi, GM, Chrysler, Peugeot, Regal, Beijing Jeep, Citroen and other most popular models |

If the DLC cannot be found, refer to the vehicle's service manual for the location.

3 Product Descriptions

3.1 General Controls

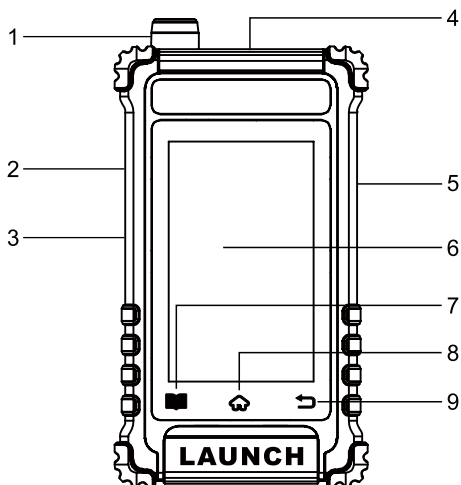

1. TPMS Antenna

2. TF Card Slot

3. Charging Port

Connect the power adaptor charge the tool.

4. DB15 Diagnostic Connector

Connects the tool to the vehicle's Data Link Connector (DLC).

5. Power Button

Turns on/off the tool.

6. Display Screen

Indicates test results.

7. Setting Button

Quick access to the Settings screen.

8. HOME Button

Navigate to the Job Menu screen.

9. Button

Returns to previous menu.

3.2 Specifications

- Screen: 4" LCD display with a resolution of 400*800 dpi
- Input voltage: 9 ~ 18V via OBD diagnostic port / 5V via USB cable
- Operating temperature: 32°F~122°F / 0°C~50°C
- Storage temperature: -4°F~158°F / -20°C~70°C @ RH60%
- Size: 159*88*37 mm

3.3 Accessory Included

The following accessory items are for reference purpose only. For different destinations, the accessories (such as power adaptor or RF sensor) may vary. For details, please consult from the local dealers.

- Smart TPMS Diagnostic Tool X 1
- Diagnostic Cable X 1
- Charging Cable & Power Adaptor X 1
- Quick Start Guide X 1

4 Initial Use

4.1 Charging & Turning On/Off

4.1.1 Charging

There are three methods available for charging the tool.

1. Via AC outlet

Connect one end of the charging cable to the charging port of the tool, and other end to the power adaptor. Plug the power adaptor into a AC outlet to start charging.

When charging is finished the charging complete symbol  replaces the charging symbol. Unplug the power adaptor from the AC outlet and disconnect the charging cable from the tool.

2. Via OBD Diagnostic Port (Not recommended)

If the tool is properly connected to the vehicle's DLC(Data Link Connector) port, it will be charged automatically.



Note: Attempting to charge the tool via OBD diagnostic port will consume vehicle's battery power. You are not recommended to charge the tool in this way except for OBD diagnosis operations.

4.1.2 Turning On/Off

Press  for about 3 seconds to turn it on.

Press  for about 8 seconds to turn it off.

4.2 Getting Started

If it is the first time you have used this tool, you need to make some system settings.

1. Power on the tool. The screen displays a welcome page. Tap **Welcome to use** to go to next step.
2. Choose the desired system language, and tap **Next step**.
3. Choose the desired time zone, and tap **Next step** to enter the WLAN setup screen.
4. Slide the switch to ON, the system starts searching for all available wireless

LANs. Choose the desired WLAN access point / network,

- If the network you chose is open, you can connect directly.
- If the selected network is encrypted, you have to enter the right security key (network password).

 Note: If you choose **Ignore** in WLAN setup, it will go into the date setting page. If the tool has been properly connected to the Internet, the system will automatically obtain the correct network date and time and navigate to step 5.

5. After the network connection is done, tap **Next Step** to configure workshop information. Input the required information, and tap **Next Step** to go to next step.

 Note: After you configured it, the system will append it on the report every time a report is successfully generated.

6. Carefully read all terms and conditions of the user agreement, check the box before the **Agree to all the above terms**, and tap **OK** to finish the sign-up process and navigate to Job Menu.

4.2 Job Menu

The main menu screen includes the following function modules:

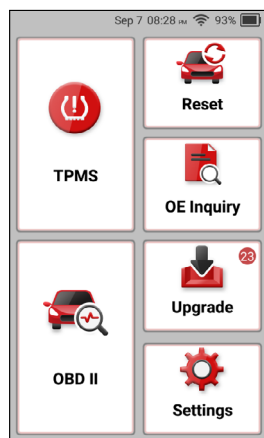

| Modules | Descriptions |
|-------------------|---|
| TPMS | Perform various TPMS operations. It mainly includes TPMS sensor activation, programming, relearning and TPMS diagnostics functions. |
| OBD II | This function presents a quick way to check for DTCs, isolate the cause of the illuminated Malfunction Indicator Lamp (MIL), check monitor status before emissions certification testing, verify repairs, and perform other services that are emission-related. |
| Reset | Perform commonly used repair & maintenance services. |
| OE Inquiry | Inquires the original OE part number of the sensor and check which vehicle models the sensor can be applied on. |
| Upgrade | Update the diagnostic software and APK. |
| Settings | Make some system adjustment and setting of the tool to your particular needs. |

4.3 Settings

4.3.1 Units of measurement

It is designed to set the measurement unit. Metric System and English System are available.

4.3.2 Automatic detection on connect

This option enables you to determine whether to start an automatic VIN detection once the tool is properly connected to the vehicle's DLC.

4.3.3 Firmware Fix

This option enables you to fix and repair the tire pressure firmware and the VCI firmware.

4.3.4 Report

This option allows you to manage diagnostic report.

4.3.5 Display/Brightness

This item allows you to set the standby time and screen brightness.



Note: Reducing the brightness of the screen is helpful to conserve the power of the tool.

4.3.6 Sound

This option lets you adjust the volume and other sound settings.

4.3.7 Network



Note: Once WLAN is set as ON, the tool will consume more power. While it keeps unused, please set it off to save power. While WLAN keeps unused, please turn it off to conserve battery power.

The tool has built-in WLAN module that can be used to get online. Once you're online, you can register your tool and update diagnostic software & APK.

Slide the switch to ON, the system starts searching for all available wireless LANs. Choose the desired WLAN access point / network to connect.

4.3.8 Time Zone

This option allows you to set the system time zone.

4.3.9 Language

The tool supports multiple languages. You can use this option to change the system language to the target language.

4.3.10 Region (TPMS)

This option allows you to set the target region where the TPMS sensors are being applied.

4.3.11 Workshop information

This option can set up the default email address for receiving the diagnostic reports or screenshots.

4.3.12 Recovery

Use this item to reset this tool to the default factory setting.



Warning: Resetting may cause data loss. Before doing so, please be careful to perform this operation.

4.3.13 Clean Up

This option allows user to clear some cache files and free up some storage space. After clean up, the tool will reboot automatically.

4.3.14 Screen Capture

This option can set the Screen Capture icon to be shown or not on the screen.

4.3.15 Data

1. DTC Library

This option enables you to retrieve the detailed description of certain DTC from the local DTC database.

Swipe the screen upwards / downwards to alter the value, then tap **OK**, the screen will display definition of the DTC.

2. DLC (Data Link Connector) Location

This option helps you to find the location of the vehicle's DLC.

3. Image

This option allows you to view and manage all screenshots.

4. Feedback

This function allows you to send the feedback of your diagnostic problems to us for further analysis and troubleshooting.

There are 3 options:

- 1) Diag. Feedback: To send a tested vehicle diagnostic feedback.
- 2) History Feedback: To view all diagnostic feedback records.
- 3) Offline Feedback: To view all diagnostic feedback logs that have failed to be submitted, which will be uploaded again to the remote server automatically once the tablet gets the stable network.

5. FAQ

The option collects some frequently asked questions and solutions.

6. Product Manual

The user manual is integrated on the tool for your easier check and reference.

4.16 About

This option displays the hardware configuration information of the tool and license agreement.

5 TPMS Operations

For initial use, please follow the flow chart below to start using it.

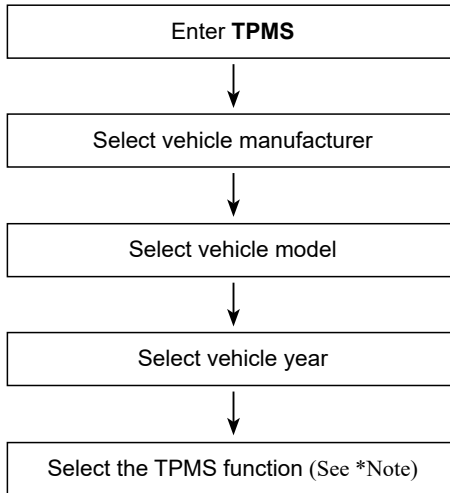

 Note: For indirect TPMS vehicle, only the Relearning function is supported. For vehicle using Direct TPMS, it generally includes: Activation, Programming and Relearning. The available TPMS functions may vary for different vehicles being serviced.

Take **BMW** for example to demonstrate how to perform the TPMS functions.

1. Tap **TPMS** on the Job Menu screen to enter the vehicle selection screen.

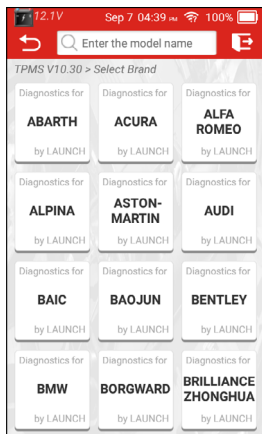

2. Tap **BMW** to enter the vehicle model selection screen.

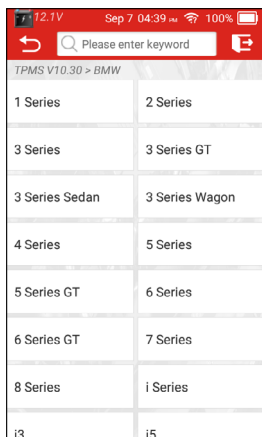

3. Tap **5 Series** to enter the following year selection screen.



4. Tap the desired option to enter the TPMS function selection screen.

 Note: For indirect TPMS vehicle, only the Learning function is supported. For vehicle using Direct TPMS, it generally includes: Activation, Programming and Relearning. The available TPMS functions may vary for different vehicles being serviced.

5.1 Activate Sensor

This function allows users to activate TPMS sensor to view sensor data such as sensor ID, tire pressure, tire frequency, tire temperature and battery condition.

1. Tap the **Activate** tab to enter the following screen.

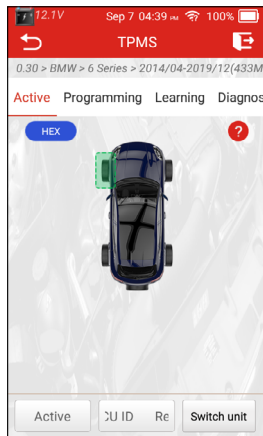

2. For universal sensors, place the TPMS antenna of the tool alongside the valve stem, point toward the sensor location, and tap **Activate** on the screen.

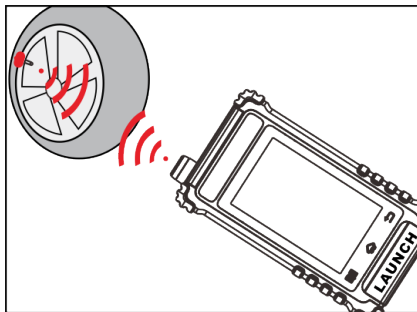

 Notes:

1. For early magnet-activated sensors, place the magnet over the stem and then place the tool alongside the valve stem.
 2. If the TPMS sensor requires tire deflation (of the order of 10PSI), then deflate the tire and place the tool alongside the stem while tapping **Activate** on the screen.
-

Once the sensor information is successfully retrieved, the tool will sound a series of beep and the screen will display the sensor data in the *Ac ID* field.

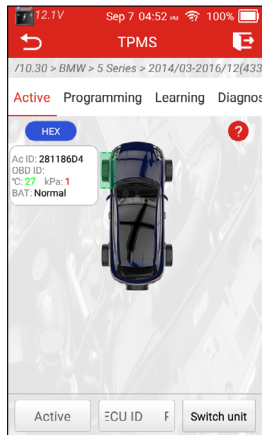

Notes:

1. The tool will do TPMS test in a sequence of FL (Front Left), FR (Front Right), RR (Rear Right), LR (Rear Left) and SPARE, if the vehicle has the option for the spare. Or, you can use the ▲ / ▼ / ◀ / ▶ button to move to the desired wheel for testing.
 2. If the sensor fails to be triggered, the Fail message will appear next to the wheel position.
 3. If the sensor data is abnormal, it will be displayed in red.
-
3. Repeat Step 2 for other vehicle sensors. After all sensors are successfully activated, the following screen will appear:

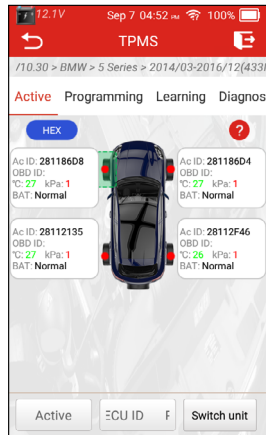

If the users intend to read the original sensor ID stored in the ECU, connect the tool to the vehicle's DLC via the diagnostic cable and tap **Read ECU ID** to read the information of the four TPMS sensors. After the sensor information is successfully decoded, tap **OK**, it will be displayed in the *OBD ID* field.

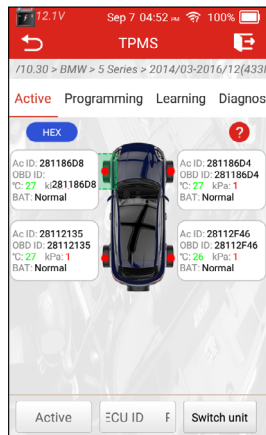

 Note:

Ac ID: indicates the ID of the sensor installed on the vehicle's wheel.

OBD ID: indicates the original sensor ID. It can be obtained through connecting to the vehicle's OBD socket. If the OBD ID is different from the Activation ID, the sensor information of the current wheel will be marked in red.

°C: indicates the tire pressure.

kPa: indicates the tire temperature.

The measurement units mentioned above can be converted by tapping **Switch Unit**.

BAT: indicates the battery power level.

5.2 Program Sensor

This function allows users to program the sensor data to the LAUNCH-sensor and replace faulty sensor with low battery life or one that is not functioning.

The following options are available for programming LAUNCH-sensor: Auto Create, Manual Create, Copy ID by Activation and Copy ID by OBD.

Tap the **Programming** tab to enter the following screen.

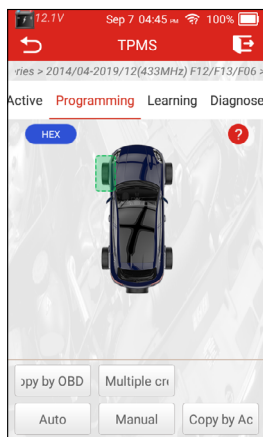

5.2.1 Auto create

This function is designed to program the LAUNCH-sensor by applying random

IDs created according to the test vehicle when it is unable to obtain the original sensor ID.

Select the wheel which needs to be programmed on the tool, place a LAUNCH-sensor close to the TPMS antenna of the tool, and tap **Auto** to create a new random sensor ID.

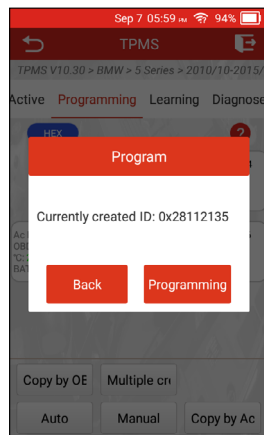

Tap **Programming** to start detecting the sensor and writing the new created sensor ID to the LAUNCH-sensor. A progress bar will appear on the screen indicating the programming process. If the progress bar reaches to 100%, it indicates the sensor has been successfully programmed.

 Note: If Auto Create is selected, the TPMS Relearn operation needs to be performed after programming all required LAUNCH-sensor.

5.2.2 Manual input

This function allows users to manually enter sensor ID. Users can enter the random ID or the original sensor ID, if it is available.

Tap **Manual** to enter the following screen.

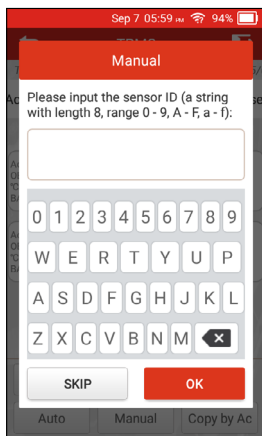

Use the on-screen virtual keypad to input a random or original (if available) sensor ID and tap **OK**.

 Note: Do not enter the same ID for each sensor.

Select the wheel which needs to be programmed on the tool, place a LAUNCH-sensor close to the TPMS antenna of the tool. Tap **Programming** to start writing the new sensor ID to the LAUNCH-sensor.

After the sensor is successfully programmed, it will appear on the screen.

 Notes:

1. If a random ID is entered, please perform the TPMS Relearn function after programming is finished. If the original ID is entered, there is no need to perform Relearn function.
 2. If a vehicle does not support relearn function, please select the Manual Input option to enter the original sensor ID manually, or trigger the original sensor at the activation screen to get its information, before programming the LAUNCH-sensor.
-

5.2.3 Copy by Activation

This function allows users to write in the retrieved original sensor data to the

LAUNCH-sensor. It is used after the original sensor is triggered.
Tap **Programming** to enter the following screen.

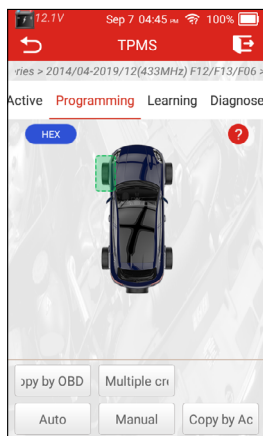

Select the specific wheel position and tap **Copy by Activation** to retrieve the information of the original sensor. After the information is retrieved, it will be displayed on the screen.

Place a LAUNCH-sensor close to the TPMS antenna of the tool, tap **Programming** to start writing the retrieved sensor information to the LAUNCH-sensor.

After the sensor is successfully programmed, it will appear on the screen.

 Notes: Once programmed with **Copy by Activation**, the LAUNCH-sensor can be installed in the wheel directly to be mounted on the vehicle and the TPMS warning light will turn off.

5.2.4 Copy by OBD

This function allows users to write in the saved sensor information to the LAUNCH sensor after performing **Read ECU ID**. This function requires a connection with the vehicle's DLC port.

Follow the steps below to proceed:

1. Tap the **Activate** tab to enter the following screen.

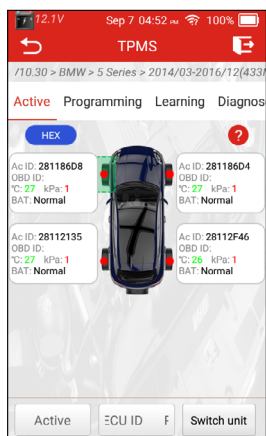

2. Tap **Read ECU ID**. Connect the tool to the vehicle's DLC port and tap **OK** to start reading the sensor IDs and positions for viewing.
3. Tap **OK** to confirm and then tap the **Programming** tab to enter.

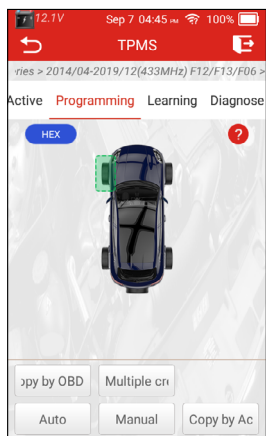

4. Place a LAUNCH-sensor close to the TPMS antenna of the tool, select the desired wheel position and tap **Copy by OBD**.

5. Tap **Programming** to start writing the copied sensor information to the LAUNCH-sensor.

5.3 Learning Service

This function allows you to check and view the detailed TPMS sensor relearn procedures.

Relearn operation applies only when the newly programmed sensor IDs are different from the original sensor IDs stored in the vehicle's ECU. Relearn is used to write the newly programmed sensor IDs into the vehicle's ECU for sensor recognition.

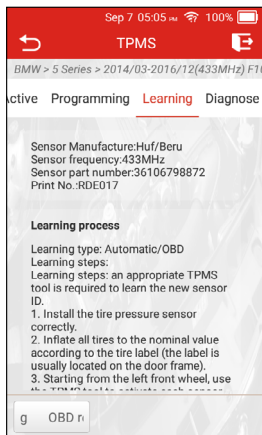

On-screen Buttons:

OBD Relearning: Tap to write the newly programmed sensor IDs into the vehicle's ECU via vehicle's DLC socket.



Note: This function requires the tool to connect with the vehicle's OBD socket.

5.4 Diagnose

This function allows you to read/clear TPMS diagnostic trouble codes.

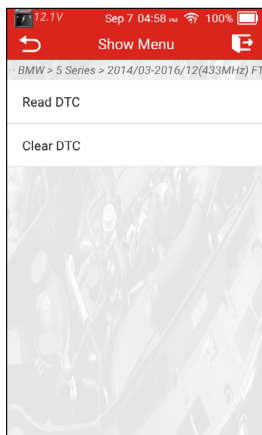

On-screen Buttons:

Read DTC: Tap to read the TPMS diagnostic trouble codes stored in the vehicle's ECU.

Clear DTC: Tap to clear the existing TPMS diagnostic trouble codes.

Note:

- This function requires the tool to connect with the vehicle's OBD socket.
 - This function may vary for different vehicles being serviced.
-

5.5 OE Inquiry

This function allows you to check the OE number of the sensors.

Tap OE Inquiry on the Job Menu screen to enter the following screen.

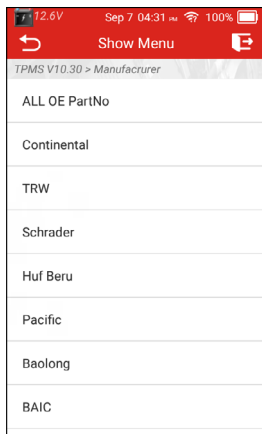

Tap the target sensor manufacturer to enter the following screen.



Check the original manufacturer number on the body of the sensor, and tap the corresponding OE number on the screen to enter the following screen.

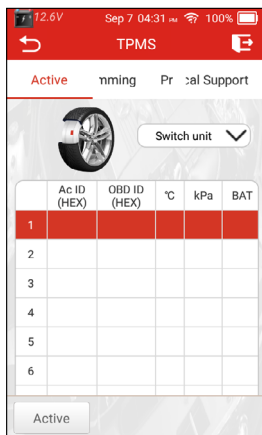

Tap **Activate** to trigger and check the sensor data.

Tap **Programming** to write the sensor data into a new blank LAUNCH-sensor.

Tap **Technical Support** to check which vehicle models the sensor can be applied on.

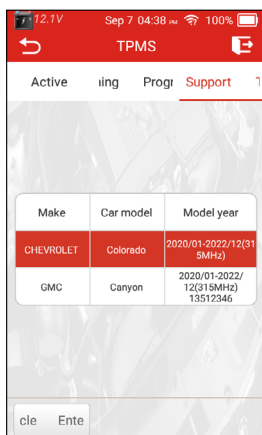

6 OBD II Diagnosis

6.1 Connection

- 1). Turn the ignition off.

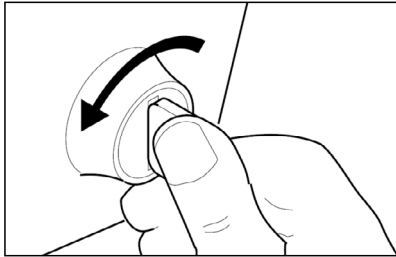

- 2). Locate the vehicle's 16-pin Data Link Connector (DLC). Refer to Chapter 2.4.
- 3). Plug one end of the diagnostic cable into the vehicle's DLC(Data Link Connector) port, and the other end to the DB-15 diagnostic connector of the tool, and then tighten the captive screws.

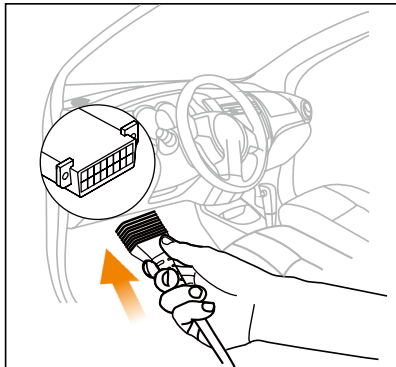

 Notes:

- A plastic DLC cover may be found for some vehicles and you need to remove it before plugging the diagnostic cable.
 - The cable connector is keyed and will only fit one way. If you have problems connecting the cable connector to the DLC, rotate the connector 180° and try again.
-

4). Turn the ignition on. Engine can be off or running.

 Caution: Don't connect or disconnect any test equipment with the ignition on or engine running.

5). The system automatically turns on and navigates to the main menu screen.

6.2 Start Diagnostics

This function presents a quick way to check for DTCs, isolate the cause of the illuminated Malfunction Indicator Lamp (MIL), check monitor status before emissions certification testing, verify repairs, and perform other services that are emission-related.

Tap **OBD II** in the Home Menu after the tablet is properly connected to the vehicle's DLC port. The tablet will start an automatic check of the vehicle's computer to determine which type of communication protocol it is using, then display the Monitor Status as follows:

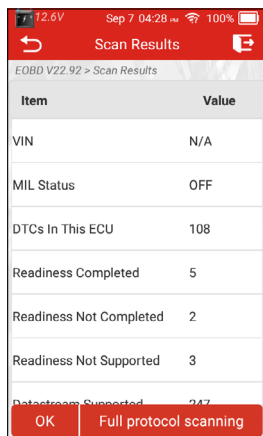

| Item | Value |
|-------------------------|-------|
| VIN | N/A |
| MIL Status | OFF |
| DTCs In This ECU | 108 |
| Readiness Completed | 5 |
| Readiness Not Completed | 2 |
| Readiness Not Supported | 3 |
| Detectores Soportados | 217 |

Tap **OK**, the following OBDII function list appears.

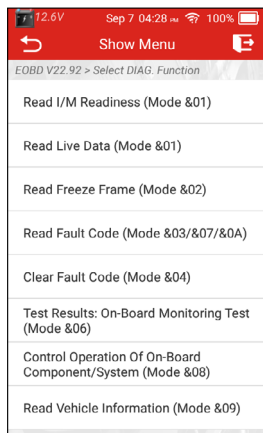

| |
|---|
| Read I/M Readiness (Mode &01) |
| Read Live Data (Mode &01) |
| Read Freeze Frame (Mode &02) |
| Read Fault Code (Mode &03/&07/&0A) |
| Clear Fault Code (Mode &04) |
| Test Results: On-Board Monitoring Test (Mode &05) |
| Control Operation Of On-Board Component/System (Mode &08) |
| Read Vehicle Information (Mode &09) |

6.2.1 Read I/M Readiness

This function checks whether or not the various emissions-related systems on the vehicle are operating properly, and are ready for Inspection and Maintenance testing.

It can also be used to check the Monitor Run Status, and to confirm if the

repair of a car fault has been performed correctly.

6.2.2 Read Live Data

This function retrieves and displays live data and parameters from the vehicle's ECU.

6.2.3 Read Freeze Frame

This function takes the snapshot of the operating conditions when an emission-related fault occurs.

6.2.4 Read Fault Code

This function can identify which section of the emission control system has malfunctioned.

 Note: Retrieving and using DTCs for troubleshooting vehicle operation is only one part of an overall diagnostic strategy. Never replace a part based only on the DTC definition. Each DTC has a set of testing procedures, instructions and flow charts that must be followed to confirm the location of the problem. This information can be found in the vehicle's service manual.

6.2.5 Clear Fault Code

This function erases the codes from the vehicle, after retrieving codes from the vehicle and certain repairs have been carried out.

Make sure the vehicle's ignition key is in the ON position with the engine off before the operation.

 Notes:

1. If you plan to take the vehicle to a Service Center for repair, DO NOT erase the codes from the vehicle's computer. If data is erased, valuable information that might help the technician troubleshoot the problem will also be erased.
 2. Clearing DTCs does not fix the problem(s) that caused the code(s) to be set. If proper repairs to correct the problem that caused the code(s) to be set are not made, the code(s) will appear again and the check engine light will illuminate as soon as the problem that cause the DTC to set manifests itself.
-

6.2.6 Test Results: On-Board Monitoring Test

This function retrieves test results for emission-related powertrain components and systems that are not continuously monitored. The test's availability is determined by the vehicle manufacturer.

6.2.7 Control Operation of On-Board Component/System

This option is used to access vehicle-specific subsystem and component tests. Available tests vary by vehicle manufacturer, year, and model.

6.2.8 Read Vehicle Information

This function retrieves a list of information (provided by the vehicle manufacturer) from the vehicle's on-board computer.

This information may include: VIN (Vehicle Identification Number), CID (Calibration ID) and CVN (Calibration Verification Number).

7 Reset

In addition to amazing & powerful diagnostic function, the tool also features various service functions.

There are two methods to reset service lamp: Manual Reset or Auto Reset. Auto Reset follows the principle of sending command from the tool to vehicle's ECU to do resetting. While using Manual Reset, users just follow the on-screen instructions to select appropriate execution options, enter correct data or values, and perform necessary actions, the system will guide you through the complete performance for various service operations.

Follow the flowchart shown as below to perform resetting.

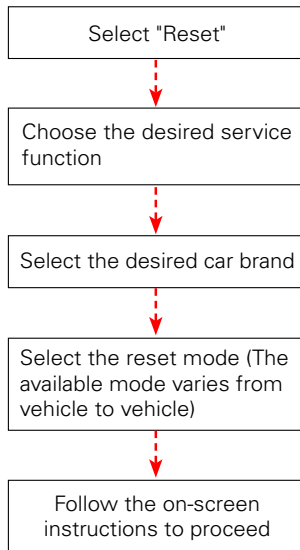

7.1 Maintenance Light Reset (Oil Reset)

This function enables you to reset the oil service lamp for the engine oil life system, which calculates an optimal oil life change interval depending on the vehicle driving conditions and weather events.

It needs to be performed in the following cases:

- If the service lamp is on, run car diagnostics first for troubleshooting.

After that, reset the driving mileage or driving time, so as to turn off the service lamp, and enable a new driving cycle.

- If the service lamp is not on, but you have changed the engine oil or electric appliances that monitor oil life, you need to reset the service lamp.

7.2 Electronic Parking Brake Reset (BRAKE RESET)

This function helps you to replace and reset the brake pad.

It needs to be performed in the following cases:

- The brake pad and brake pad wear sensor are replaced.
- The brake pad indicator lamp is on.
- The brake pad sensor circuit is short, which is recovered.
- The servo motor is replaced.

7.3 Steering Angle Calibration (SAS RESET)

This function can reset the steering angle to zero to keep the car running straight.

It needs to be performed generally after replacing the steering angle position sensor, or after replacing the mechanical parts of the steering system (such as steering gear, steering column, tie rod ball head, steering knuckle), or after completing the four-wheel positioning, body repair, etc.

7.4 Battery Matching (BAT. RESET)

This function can reset the monitoring unit of the car battery, by clearing the original breakdown information about the lack of battery power to rematch the battery.

It needs to be performed in the following cases:

- The replacement of the main battery needs to utilize battery matching to clear the former information about the lack of power, thus avoiding false information detected by the relevant control module which may cause the failure of some electronic auxiliary functions. For example, the vehicle automatically stops; the sunroof can't work by one key; electric windows can't open and close automatically.
- The battery monitoring sensor uses the battery matching function to rematch the control module with the monitoring sensor, so as to detect the use of the battery power more accurately, and avoid receiving wrong information from instrument prompts which will cause false alarms.

7.5 Throttle Matching (ELEC. THROTTLE RLRN)

This function can initialize the throttle actuator so that the learning value of the ECU returns to the initial state. By doing so, the movement of the throttle (or idle motor) can be more accurately controlled, thus adjusting the intake volume.

It needs to be performed in the following cases:

- After replacing the electronic control unit, the relevant characteristics of the throttle operation have not been stored in the electronic control unit.
- After the electric control unit is powered off, the memory of the electric control unit's memory is lost.
- After replacing the throttle assembly, you need to match the throttle.
- After replacing or disassembling the intake port, the controlling of the idle speed by the coordination between the electronic control unit and the throttle body is affected.
- The intake volume, and the idle control behavior has changed while staying at the same throttle opening position, although the idle throttle potentiometer behavior hasn't changed.

8 Upgrade

If some new software or APK can be updated, a numeric indicator will display on the **Upgrade** module on the Job menu. In this case, you may use this option to keep it synchronized with the latest version.

Notes:

- To enjoy more functions and better service, you are strongly suggested to update it on regular basis.
- This function requires a stable network connection.

Tap **Upgrade** on the Job menu to enter the update center.

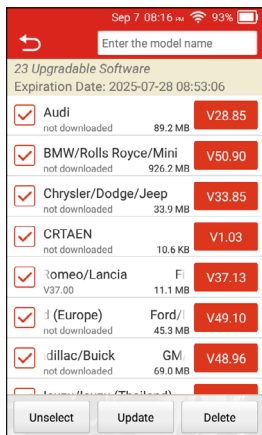

By default, all diagnostic software is selected.

To deselect certain software, tap **Unselect**, and then check the box next to vehicle model.

Tap **Update** to start downloading. Once download is finished, the software packages will be installed automatically.

9 FAQ

Here we list some frequently asked questions and answers relating to this tool.

Question: System halts when reading data stream. What is the reason?

Answer: It may be caused by a slackened connector. Please turn off the tool, firmly connect the connector, and switch it on again.

Question: Screen of main unit flashes at engine ignition start.

Answer: Caused by electromagnetic disturbing, and this is normal phenomenon.

Question: There is no response when communicating with on-board computer.

Answer: Please confirm the proper voltage of power supply and check if the throttle has been closed, the transmission is in the neutral position, and the water is in proper temperature.

Question: Why are there so many fault codes?

Answer: Usually, it's caused by poor connection or fault circuit grounding.

Warranty

THIS WARRANTY IS EXPRESSLY LIMITED TO PERSONS WHO PURCHASE LAUNCH PRODUCTS FOR PURPOSES OF RESALE OR USE IN THE ORDINARY COURSE OF THE BUYER'S BUSINESS.

LAUNCH electronic product is warranted against defects in materials and workmanship for one year (12 months) from date of delivery to the user.

This warranty does not cover any part that has been abused, altered, used for a purpose other than for which it was intended, or used in a manner inconsistent with instructions regarding use. The exclusive remedy for any automotive meter found to be defective is repair or replacement, and LAUNCH shall not be liable for any consequential or incidental damages.

Final determination of defects shall be made by LAUNCH in accordance with procedures established by LAUNCH. No agent, employee, or representative of LAUNCH has any authority to bind LAUNCH to any affirmation, representation, or warranty concerning LAUNCH automotive meters, except as stated herein.

Order Information

Replaceable and optional parts can be ordered directly from your LAUNCH authorized tool supplier. Your order should include the following information:

1. Quantity
2. Part number
3. Item description

Customer Service

If you have any questions on the operation of the unit, please contact local dealer, or contact LAUNCH TECH. CO., LTD.

RF Exposure Information:

FCC RF Exposure requirements: The highest SAR value reported under this standard during product certification for use next to the Body with the minimum separation distance of 0mm. This transmitter must not be collocated or operating in conjunction with any other antenna or transmitter.

This product is compliance to FCC RF Exposure requirements and refers to FCC website <https://apps.fcc.gov/oetcf/eas/reports/GenericSearch.cfm> search for FCC ID: XUJCRT511S