

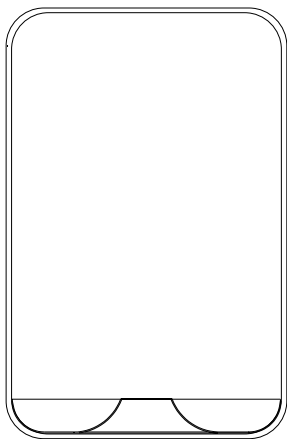

LeEco 2.1 Channel
Sound Bar with Wireless Subwoofer

User Guide



Product Layout

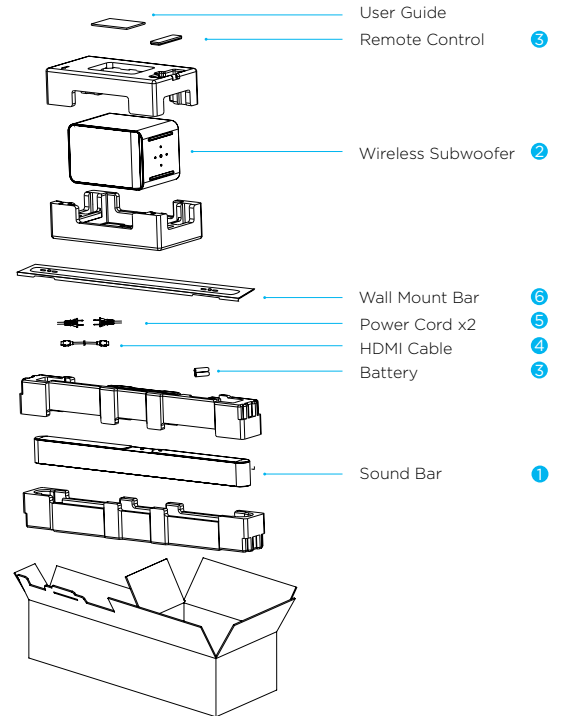
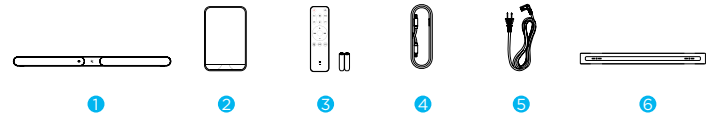

Product Overview

Sound Bar

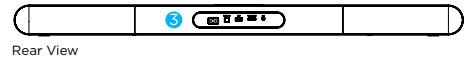
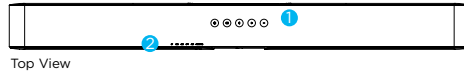

1 Buttons

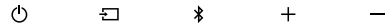

2 LED Indicator Printing

BT ECO USB OPT AUX HDMI(ARC)

3 Connections

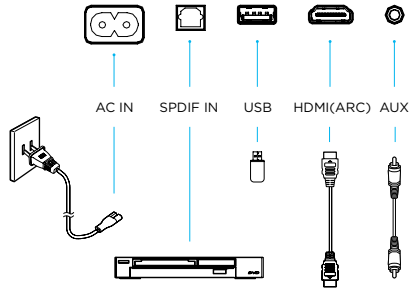

Subwoofer

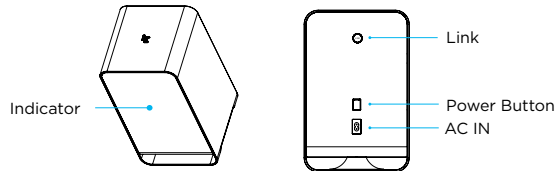

Remote Control Buttons and Functions

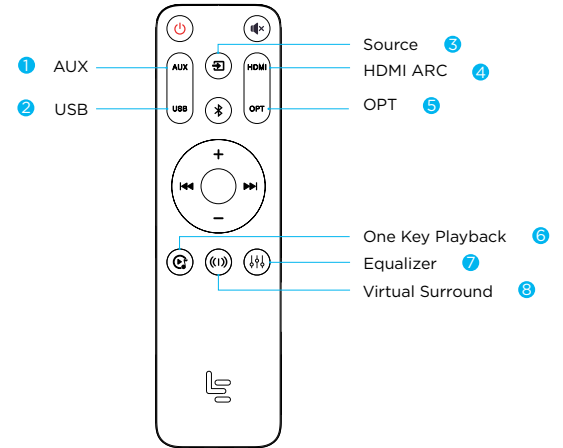

- 1 Select the 3.5mm connector
- 2 Select the USB drive (or portable hard disk) and read the list of tracks
- 3 Switch between sources: Bluetooth/USB/OPT/AUX/ARC
- 4 Select the HDMI (ARC) connector
- 5 Select the SPDIF (optical) connector
- 6 Playback music content directly from USB drive
- 7 Bass and Treble adjustments (for details please refer to Sound Bar Operations)
- 8 Turn virtual surround effect on and off

Sound Bar Operations

Initial configuration

- After you connect the sound bar and the subwoofer to power supply, the system will turn on automatically after connection.
- The sound bar and the subwoofer has been paired. No pairing is needed.
- The recommended connection from the sound bar to the TV is HDMI(ARC). HDMI cable is included to provide optimal audio experience with this system.

System operations

1. Surround sound mode

- Press the "Ⓜ" button on the remote control to turn the surround sound effect on or off.

2. Adjusting volume

- Press the Volume +/- buttons on the remote control to increase/decrease the volume.
- Press the Mute button to mute volume. To unmute, press the mute button again or press Volume +/- button.

3. Equalizer Adjustment

- Adjust the bass: press the "🔊" Equalizer button on the remote to enable bass adjustment. Please make sure the 3 left-most indicator LEDs on the sound bar flashes 3 times simultaneously to confirm that the bass adjustment has been enabled. Use the Volume +/- to adjust to adjust the bass up or down.
- Adjust the treble: press the "🔊" Equalizer button on the remote to enable treble adjustment. Please make sure the 3 right-most indicator LEDs on the sound bar flashes 3 times simultaneously to confirm that the treble adjustment has been enabled. Use the Volume +/- to adjust to adjust the treble up or down.
- Note: Please refer to the LED Indicator Light Overview for more details to understand when bass or treble adjustments are enabled.

4. Play audio via Bluetooth

- Connect the sound bar to an external Bluetooth device (such as iPad/iPhone/Android phone) via Bluetooth and enjoy music on the connected device using the sound bar.
- Press the Bluetooth button on the sound bar or remote control to turn on Bluetooth and enter pairing state. The Bluetooth indicator (white) on the sound bar will flash quickly.
- Turn on Bluetooth on the external device, and search for and select "LHT-V16S".

- Note: Connecting the sound bar to the TV via Bluetooth is not recommended as it will not provide the optimal audio experience. We strongly recommend using HDMI (ARC) connection with your TV.
- When the Bluetooth indicator on the sound bar is glowing white, the connection is established.

5. Auto standby mode

- If the sound bar stays idle and receives no signal for 30 minutes, it will automatically enter standby mode. (Please note: after entering auto standby mode, press the power key to wake up)

6. Pairing with the subwoofer



- When you turn on the sound bar and subwoofer, they will pair automatically.
- Please pair the subwoofer manually if no sound is coming from the subwoofer.
- Press and hold the "Link" button on the back of the subwoofer for more than 3 seconds, to enter the pairing state.
- Then press the "Bluetooth" and the "Source" buttons on the sound bar simultaneously for more than 2 seconds. The sound bar and the subwoofer will connect wirelessly.
- Note: During the pairing process, the indicator light on the sound bar will change accordingly. Please refer to the LED Indicator Light Overview for more details.

7. Restoring factory settings

- To reset the sound bar, press and hold the Source, Volume + and Volume - buttons for more than 2 seconds, and the sound bar will automatically shut down and restart.

LED Indicator Lights Overview

LED Indicator Lights	Status Display	Status Description
BT ●○○○○○	White light on with sounds	Bluetooth connection active
	Light off	Bluetooth connection off
	White light flashing quickly	Sound bar in Bluetooth pairing mode. Enter pairing mode on the device to be connected. Select "LHT-V16S" and pair.
USB ○○●○○○	White light flashing slowly	Not connected or connection failed
	White light on	USB source selected
	White light off	USB source deselected
	White light flashing slowly	Loading USB data
AUX ○○○○●○	White light flashing quickly	USB data loaded, waiting for "Play" button to be pressed
	White light on	AUX source selected
	White light off	AUX source deselected
HDMI ○○○○●●	White light on	HDMI source selected
	White light off	HDMI source deselected
ECO ○●○○○○	White light on	No audio and sound bar inactive
	White light off	Active audio
Optical ○○○●○○	White light on	Optical source selected
	White light off	Optical source deselected

LED Indicator Lights	Status Display and Description
Pairing with subwoofer ●●●●●●	<ul style="list-style-type: none"> When pairing with other devices, all 6 LEDs will flash one by one in sequence When pairing succeeds, all 6 LEDs will stay on for 3 seconds If pairing fails, all 6 LEDs will flash 3 times
Adjusting the bass ●●●○○○ ⏏ □ 🔊 + -	<ul style="list-style-type: none"> Press the equalizer button once to get into bass adjustment mode. The 3 left LEDs on the sound bar will flash 3 times at the same time (press the Equalizer button on the remote control to enable bass adjustment mode). One LED will turn on when you press the Volume + button, and one LED will turn off each time you press the Volume - button. If you do not press Volume + / - button within 5 seconds, the indicator LEDs will turn off and return to their original status.
	
Adjusting the treble ○○○●●● ⏏ □ 🔊 + -	<ul style="list-style-type: none"> Press the equalizer button twice to get into treble adjustment mode. The 3 right LEDs on the sound bar will flash 3 times at the same time. (press the Equalizer button on the remote control to enable the treble adjustment mode). One LED will turn on each time you press the Volume + button, and one LED will turn off each time you press the Volume - button. If you do not press Volume + / - button within 5 seconds, the indicator LEDs will turn off and return to their original status.
	
Surround sound ○○●●○○ ●○○●○○	<ul style="list-style-type: none"> When turning off the surround sound effect: LEDs 3 and 4 will flash 3 times, then return to their original state. When turning on the surround sound effect: LEDs 1, 3, 4 and 6 will flash 3 times, then return to their original state.
	

Specifications

Product

Sound Bar	W x H x D: 35.4" x 2.4" x 3.5" (900mm x 60mm x 90mm) Weight: 5.6 lbs (2.56kg)
Subwoofer	W x H x D: 8.1" x 12.4" x 8.1" (205mm x 315mm x 205mm) Weight: 10.5 lbs (4.76kg)
Compatible TV	40"(1016mm)* TV and above
Remote Control	Yes
Ambient	Temperature: 32 °F - +113 °F Humidity: 20% - 80%

Sound

Feature	Virtual Surround
Enhancement	Dolby Audio & DTS Bass & Treble
Amplifier Rated Output	Sound Bar: 40W/CH x 2 Subwoofer: 80W

Connection

HDMI (ARC) output	1
USB 2.0	1
SPDIF (optical) in	1
AUX in (3.5mm Stereo Audio)	1

Important Safety Instructions

1. Please read, keep and follow these instructions. Keep this Guide for reference.
2. Do not use this apparatus near water.
3. Clean only with dry cloth.
4. Do not block any ventilation openings. Install in accordance with the manufacture's instructions.
5. Do not install near any heat sources such as radiators, heat registers, stoves, or other apparatus (including amplifiers) that produce heat.
6. Do not defeat the safety purpose of the polarized or grounding plug. A polarized plug has two blades with one wider than the other. A grounding plug has two blades and a third grounding prong. The wide blade or the third prong is provided for your safety. If the provided plug does not fit into your outlet, consult an electrician for replacement of the obsolete outlet.
7. Protect the power cord from being walked on or pinched particularly at the plugs, convenience receptacles, and at the point where they exit from the apparatus.
8. Only use attachments/accessories specified by the manufacturer.
9. Unplug during lightning storms or when unused for long periods of time.
10. Refer all servicing to qualified personnel. Servicing is required when the apparatus has been damaged in any way, such as power supply cord or plug is damaged, liquid has been spilled or objects have fallen into the apparatus has been exposed to rain or moisture, does not operate normally, or has been dropped.

WARNING: To reduce the risk of fire or electric shock, do not expose this apparatus to rain or moisture. The apparatus shall not be exposed to dripping or splashing and that objects filled with liquids, such as vases, shall not be placed on apparatus.

WARNING: The mains plug/appliance coupler/direct plug-in adapter is used as disconnect device, the disconnect device shall remain readily operable.

WARNING: The battery (battery or batteries or battery pack) shall not be exposed to excessive heat such as sunshine, fire or the like.

WARNING: Please refer the information on exterior bottom enclosure for electrical and safety information before installing or operating the apparatus. Do not install this equipment in a confined or building-in space such as a book case or similar unit, and remain a well ventilation conditions at open site. The ventilation should not be impeded by covering the ventilation openings with items such as newspaper, tablecloths, curtains etc.

WARNING: To prevent injury, this apparatus must be securely attached to the floor/wall in accordance with the installation instruction.

* LeEco 2.1 Channel Sound Bar with Wireless Subwoofer is ideal for televisions 43" or larger. Wall mounting recommended for sound bar when pairing with Super4 X43 Pro ecotv.

Caution

Electric Shock Do Not Open

Caution: to reduce the risk of electric shock, do not remove cover (or back). No user-serviceable parts inside. Refer servicing to qualified service personnel.

 The lightning flash with arrowhead symbol, within an equilateral triangle is intended to alert the user to the presence of uninsulated dangerous voltage within the product's enclosure that may be of sufficient magnitude to constitute a risk of electric shock.

 The exclamation point within an equilateral triangle is intended to alert the user to the presence of important operating and maintenance (servicing) instructions in the literature accompanying the appliance.

CAUTION: RISK OF ELECTRIC SHOCK-DO NOT OPEN

CAUTION: To prevent electric shock do not use this polarized plug with an extension cord, receptacle or other outlet unless the blades can be fully inserted to prevent blade exposure.

CAUTION: These servicing instructions are for use by qualified service personnel only. To reduce the risk of electric shock, do not perform any servicing other than that contained in the operating instructions unless you are qualified to do so.

Certification Information



For DTS patents, see <http://patents.dts.com>. Manufactured under license from DTS Licensing Limited. DTS, the Symbol, DTS in combination with the Symbol, and DTS 2.0 Channel are registered trademarks or trademarks of DTS, Inc. in the United States and/or other countries. © DTS, Inc. All Rights Reserved.



Manufactured under license from Dolby Laboratories. Dolby, Dolby Audio and the double-D symbol are trademarks of Dolby Laboratories.



HDMI, High-Definition Multimedia Interface and the HDMI logo are trademarks or registered trademarks of HDMI Licensing, LLC in the United States and/or other countries.



ENERGY STAR® is a joint program of the U.S. Environmental Protection Agency and the U.S. Department of Energy helping us all save money and protect the environment through energy efficient products and practices.

This product meets ENERGY STAR® guidelines for energy efficiency. ENERGY STAR and the ENERGY STAR mark are registered U.S. marks. ENERGY STAR is a registered mark owned by the U.S. government.



The Bluetooth word mark and logos are registered trademarks owned by Bluetooth SIG, Inc. and any use of such marks by [Le Shi Zhi Xin Electronic Technology (Tian jin) Limited] is under license. other trademarks and trade names are those of their respective owners.

FCC Certification



This equipment has been tested and found to comply with the limits for a Class B digital device, pursuant to Part 15 of the FCC Rules. These limits are designed to provide reasonable protection against harmful interference in a residential installation. This equipment generates, uses and can radiate radio frequency energy and, if not installed and used in accordance with the instructions, may cause harmful interference to radio communications. However, there is no guarantee that interference will not occur in a particular installation. If this equipment does cause harmful interference to radio or television reception, which can be determined by turning the equipment off and on, the user is encouraged to try to correct the interference by one of the following measures:

- Reorient or relocate the receiving antenna.
- Increase the separation between the equipment and receiver.
- Connect the equipment into an outlet on a circuit different from that to which the receiver is connected.
- Consult the dealer or an experienced radio/TV technician for help.

Changes or modifications not expressly approved by the party responsible for compliance could void the user's authority to operate the equipment.

NOTE: THE MANUFACTURER IS NOT RESPONSIBLE FOR ANY RADIO OR TV INTERFERENCE CAUSED BY UNAUTHORIZED MODIFICATIONS TO THIS EQUIPMENT. SUCH MODIFICATIONS COULD VOID THE USER'S AUTHORITY TO OPERATE THE EQUIPMENT.

FCC Radiation Exposure Statement:

The equipment complies with FCC RF exposure limits set forth for an uncontrolled environment. This equipment must be installed and operated with a separation distance of at least 20 cm from all persons. The antenna(s) used for this transmitter must not be co-located or operating in conjunction with any other antenna or transmitter.

One-Year Limited Warranty

LeEco warrants the included hardware product and accessories against defects in materials and workmanship for one year from the original retail purchase. LeEco does not warrant against normal wear and tear, or damage caused by accident or abuse. For service, contact us at **+1 (855) 343.6688**. Shipping charges may apply. You may be required to provide proof of purchase in submission of your warranty claim. If you submit a valid claim under this warranty, LeEco will at its option repair your device or replace it with a new or refurbished device subject to the full warranty terms and conditions located at www.lemall.com/us/warranty and any applicable service policies at www.lemall.com. This warranty is in addition to rights provided under local consumer laws.



LeEco & LeEco 2.1 Channel Sound Bar with Wireless Subwoofer are the marks and registered trademarks of LeEco or its affiliates. Other names, trademarks or logos are the marks or registered trademarks of their respective holders.



72- TV16US- QSGB2