

MM400C

Watertight Miniature UHF Belt-Pack Transmitter

Featuring Digital Hybrid Wireless® Technology



Fill in for your records:

Serial Number:

Purchase Date:

Thank you for selecting the Lectrosonics MM400C watertight miniature transmitter. The unique design provides several distinct features for professional applications:

- Outstanding RF operating range
- Superb audio quality
- Ultra-lightweight, corrosion resistant housing
- Watertight seals for use in wet environments
- Programmable emulation modes for maximum versatility

The patented Digital Hybrid Wireless® design combines 24-bit digital audio with analog FM techniques to provide the operating range of the finest analog wireless systems and the audio quality of a pure digital system. The 100 mW RF output power extends operating range, and the DSP controlled, dual-envelope limiter cleanly handles input peaks to allow higher gain settings. This combination maximizes operating range and the signal to noise ratio of the system.

The input provides 6 VDC bias voltage for use with modern electret lavalier microphones. Multi-color

LEDs are provided to make input gain adjustments quick and accurate, without having to view the receiver. The battery compartment accepts AA alkaline, lithium or NiMH batteries, and a detachable antenna ¼ wavelength flexible cable connects to a watertight 50 Ohm SMA port on the transmitter.

The MM400C is machined from a solid aluminum block to provide the lightweight, rugged package needed in extreme environments without compromising functionality. Input jacks and controls are O-ring sealed for watertight protection in wet environments. A special noncorrosive finish resists salt water exposure and perspiration in extreme environments.

The DSP-based design offers backward compatibility with a handful of earlier analog designs, such as the Lectrosonics 100 and 200 Series receivers, and some other brands of analog wireless receivers. Compatibility Modes are easily selected with a sequence of frequency switch settings and cycling the unit's power. Only the MM400C transmitter is covered in this manual. Companion receivers are covered in separate manuals.

Table of Contents

General Technical Description	6
General	6
Digital Hybrid Wireless® Technology*	6
Low Frequency Roll-Off	6
Input Limiter	7
Digital Signal Processor	7
Microprocessor, PLL and VCO Circuits	7
Compatibility Modes	7
Pilot Tone Squelch	7
Wide-Band Deviation	7
Magnetic Power ON/OFF Switch	7
Battery Life	7
Frequency Agility	7
Circulator/Isolator	7
Controls and Functions	8
Preventing Internal Corrosion	8
Power ON/OFF Switch	8
Power LED	8
Mic Jack	9
Audio Level	9
Modulation LEDs	9
Frequency Select Switches	9
Antenna	9
Belt Clip	9
Battery Installation	10
Operating Instructions	11
Selecting the Compatibility Mode	11
Adjusting Transmitter Frequency	11
Attaching a Microphone and Adjusting Audio Levels	12
Power Switch Function Selection	13
Determine Power Switch Function Mode	13
Changing Power Switch Function	13
Replacing the Power Switch Magnet Housing Assembly	14
Microphone RF Bypassing	15
Replacement Parts and Accessories	16
UHF Transmitter Antenna Specifications	16
Troubleshooting	17
Specifications and Features	18
Service and Repair	19
Returning Units for Repair	19

General Technical Description

General

The 400 Series (or Digital Hybrid Wireless®) system uses 75 kHz wide deviation for an extremely high signal to noise ratio. The switching power supplies provide constant voltages to the transmitter circuits from the beginning (1.5 Volts) to the end (0.85 Volts) of battery life. The input amplifier uses an ultra low noise op amp for quiet operation. It is gain controlled with a wide range dual envelope input compressor which cleanly limits input signal peaks over 30 dB above full modulation.

Note: The terms 400 Series and Digital Hybrid Wireless® describe the same product line and are interchangeable.

Digital Hybrid Wireless® Technology

All wireless links suffer from channel noise to some degree, and all wireless microphone systems seek to minimize the impact of that noise on the desired signal. Conventional analog systems use companders for enhanced dynamic range, at the cost of subtle artifacts (known as “pumping” and “breathing”). Wholly digital systems defeat the noise by sending the audio information in digital form, at the cost of some combination of power, bandwidth and resistance to interference.

The Lectrosonics Digital Hybrid Wireless® system overcomes channel noise in a dramatically new way, digitally encoding the audio in the transmitter and decoding it in the receiver, yet still sending the encoded informa-

tion via an analog FM wireless link. This proprietary algorithm is not a digital implementation of an analog compandor but a technique which can be accomplished only in the digital domain, even though the inputs and outputs are analog signals.

Because it uses an analog FM link, Digital Hybrid Wireless® enjoys all the benefits of conventional FM wireless systems, such as excellent range, efficient use of RF spectrum, and resistance to interference. However, unlike conventional FM systems, the Digital Hybrid has done away with the analog compandor and its artifacts.

Low Frequency Roll-Off

A 12 dB per octave low frequency roll-off is provided in the audio section, with the -3 dB point at 70 Hz. The actual roll-off frequency will vary somewhat according to the low frequency response of the mic capsule being used.

The low frequency roll-off is used to remove subsonic (or very low frequency) audio, such as that produced by air conditioning systems or automobile traffic from the audio signal. Excessive low frequency content in the audio input can cause a variety of audio problems including driving the transmitter into limiting. For example, in sound reinforcement systems, as one instance, excessive low frequency content can cause excessive power amplifier drain or even damage to loudspeaker systems.

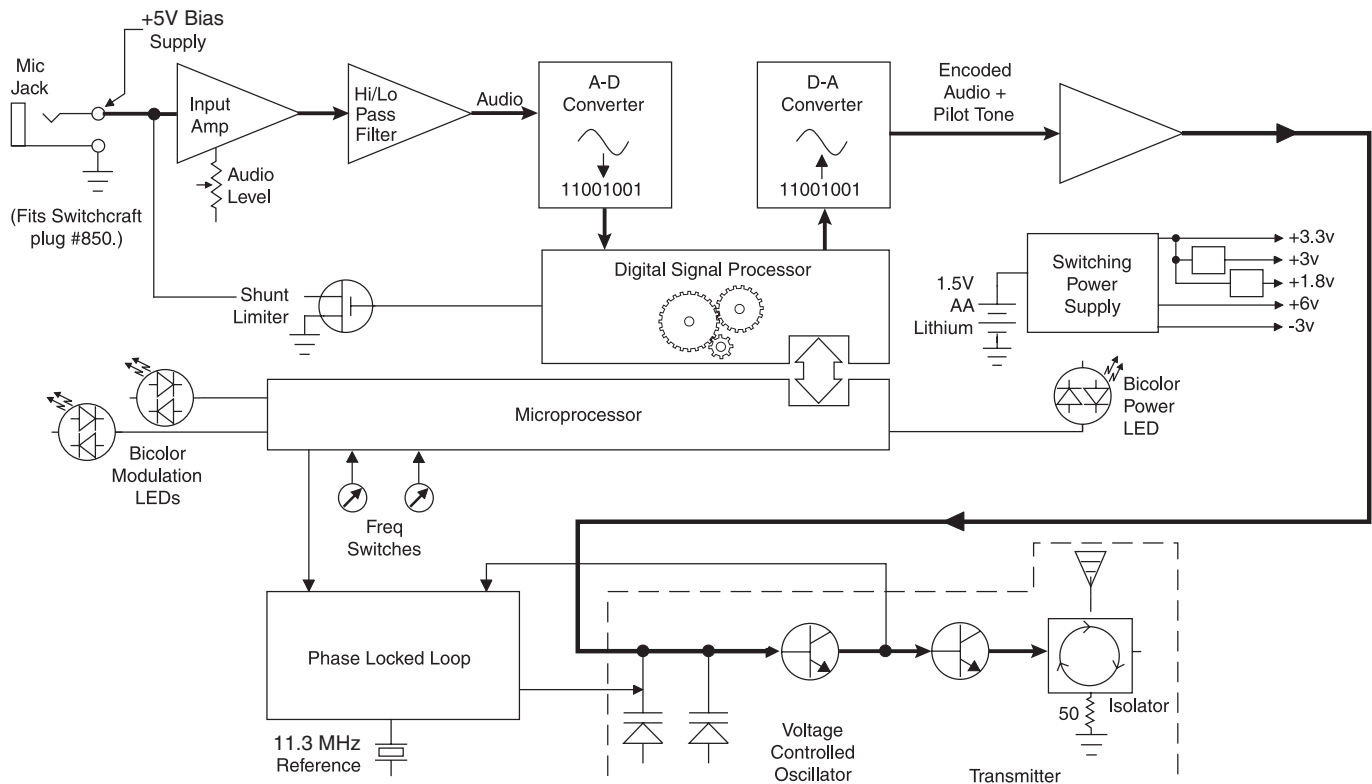

Input Limiter

The MM400C transmitters employ a DSP-controlled analog audio limiter just before the analog-to-digital converter. The limiter has a range of more than 30 dB for excellent overload protection. A dual release envelope makes the limiter acoustically transparent while maintaining low distortion. It can be thought of as two limiters in series, connected as a fast attack and release limiter followed by a slow attack and release limiter. The limiter recovers quickly from brief transients, so that its action is hidden from the listener, but recovers slowly from sustained high levels, to both keep audio distortion low and preserve short term dynamic changes.

Two bicolor LEDs indicate limiter activity. (See *Operating Instructions, Adjusting Audio Levels.*) Generally speaking, some limiting is desirable in normal operation to improve the signal to noise ratio of the system. The limiting action is not audible and does not create distortion.

Digital Signal Processor

The DSP constructs the original digitized audio from the A-D Converter, adds an ultrasonic Pilot Tone to control the receiver's squelch (only in 400 Series and 200 Series Compatibility Mode with the Pilot Tone enabled – see *Pilot Tone Squelch*), and implements the user defined Compatibility Mode.

Microprocessor, PLL and VCO Circuits

An 8-bit microprocessor monitors user command inputs and numerous other internal signals. It also drives the Modulation LEDs, controls the Pilot Tone and operates the PLL/VCO circuits.

Compatibility Modes

The MM400C transmitter was designed to be compatible with Lectrosonics 400 Series receivers and will yield the best performance when doing so. However, due to the flexibility of digital signal processing, the MM400C is also able to operate with Lectrosonics 200 Series, Lectrosonics 100 Series, IFB and certain non-Lectrosonics analog receivers in special compatibility modes. (Contact the Lectrosonics Sales Department for a complete list of compatible transmitters.)

Pilot Tone Squelch

The 400 Series wireless system uses an ultrasonic tone between 25 and 32 kHz to operate the receiver squelch. The pilot tone squelch system keeps the receiver muted until it receives the pilot tone from the matching transmitter, even if a strong RF signal is present on the carrier frequency of the system. The “pilot tone” frequency is different for each of the 256 available carrier frequencies to prevent the pilot tone from being transferred to the wrong receiver via an intermodulation product.

Wide-Band Deviation

A ± 75 kHz deviation improves the capture ratio, signal to noise ratio and AM rejection of a wireless system dramatically, compared to other designs that use 30 kHz to 40 kHz deviation. This combined with a full 100 mW of power output makes a significant improvement in signal to noise ratio and maximum operating range.

Magnetic Power/Mute Switch

A magnetic switch is used to control the application of power to the MM400C circuits and as an audio mute switch. The function of this switch can be set by the user. (See *Controls and Functions, Magnetic Power ON/OFF Switch.*)

Battery Life

Switching power supplies throughout the design allow over 6 hours of operation using a single AA lithium battery. (An alkaline AA battery will provide about 1.75 hours and a 2200 mAh NiMH AA battery will provide about 4 hours of operating time.) The battery contacts are spring loaded in order to prevent “rattle” as the unit is handled.

Frequency Agility

The transmitter section uses a synthesized, frequency selectable main oscillator. The frequency is extremely stable over a wide temperature range and over time.

Two 16-position rotary switches, located on the under a waterproof cover on the bottom of the unit, provide 256 frequencies in 100 kHz steps over a 25.5 MHz range. This alleviates carrier interference problems, a definite problem in mobile or traveling applications.

Circulator/Isolator

The RF output circuit includes a one way circulator/isolator using a magnetically polarized ferrite. This device greatly reduces RF intermodulation produced when multiple transmitters are used within a few feet of each other by blocking RF from returning back into the output stage. It also provides additional RF output stage protection but is rarely seen in a wireless microphone transmitter due to its high cost.

Controls and Functions

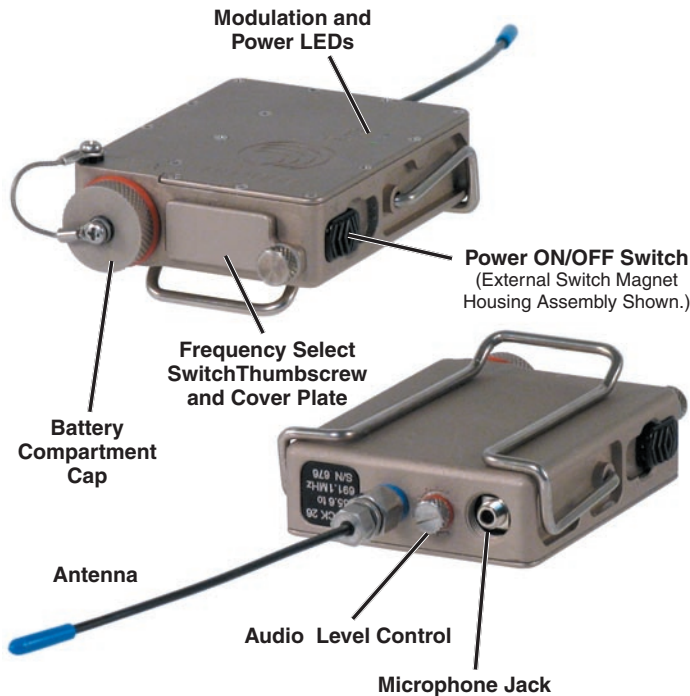

Preventing Internal Corrosion

It is very important that you properly dry the transmitter when it becomes wet due to immersion or high levels of perspiration **BEFORE** opening any covers or connectors. Follow the procedure below for best results:

1. Carefully blot the transmitter dry with a clean paper towel or cloth. **Remove all moisture.** After opening any connector or cover, carefully blot up any remaining moisture that may have remained around the seal.

IMPORTANT! DO NOT CLOSE ANY COVER OR CONNECTOR BEFORE MAKING CERTAIN THERE IS NO MOISTURE IN OR NEAR THE OPENING.

2. After use, it is important to store the transmitter in a dry place with all access compartments and connectors opened to allow any internal humidity to evaporate. Specifically, open the Battery Compartment, the Frequency Switch Cover Plate and fully unscrew and remove the microphone connector before storing. **Do not store wet and do not store sealed.** If moisture is sealed inside the unit it has nowhere to go other than to chemically react with and destroy components and the printed circuit board.
3. Lubricate all rubber O-rings with petroleum jelly (such as Vaseline) after each use (included with transmitter and O-ring replacement kits). **DO NOT USE ANYTHING OTHER THAN PURE PETROLEUM JELLY.** Silicone-based lubricants will dissolve the rubber. Failing to lubricate the O-rings after each use will significantly shorten their life.

Power ON/OFF Switch

A waterproof, magnetic Power ON/OFF switch is located on the unit's side panel. The switch actually consists of two components. A magnetically actuated internal component and a magnet housing assembly. The switch is designed so that the unit will still operate if the Switch Magnet Housing Assembly is missing or removed.

The function of the Power ON/OFF Switch can also be changed so it operates as an audio mute switch. (See *Operating Instructions, Power Switch Function Selection.*) These functions are illustrated in the chart below:

Function	Power Switch Position	
	ON	OFF
Normal, or Power Mode	Applies Power to Unit	Turns Unit Off
Audio Mute Mode	Turns On Audio	Mutes Audio Mode

If the MM400C Power ON/OFF Switch has been configured for Audio Mute Mode, it is still possible to turn off the transmitter without removing the battery. This is done by placing the switch in the ON position, then toggling the switch between the ON and OFF position three times in less than five seconds, i.e., ON (Starting Position)-OFF-ON-OFF-ON-OFF.

The user-selected configuration of the Power ON/OFF switch is stored in memory and persists until reconfigured by the user.

Power LED

The PWR LED provides an indication of the battery's condition. The PWR LED glows green when the battery is good. The color changes to red when there is about 30 minutes of operation left with the recommended lithium battery. (An alkaline battery will have about 20 minutes of life left.) When the LED begins to blink red, there are only a few minutes of life left in the battery. The PWR LED blinks red for a short period when the transmitter is configured for Normal Mode and the Power ON/OFF switch is set to OFF. At the end of the power off sequence, then PWR LED extinguishes.

Note: A NiMH battery gives little or no warning when it is depleted. If you use NiMH batteries in the MM400C, we recommend trying fully charged batteries first, noting the length of time that the batteries will run the unit, then plan for somewhat less time to determine when the battery needs to be replaced. Some Lectrosonics receivers have timers for use with these batteries.

A weak battery will sometimes cause the PWR LED to glow green immediately after being put in the unit, but will soon discharge to the point where the LED will blink red or shut off completely.

Mic Jack

The Mic Jack is a 2.5 mm microplug that is wired to accommodate two-wire positive bias lavalieres. While the M152-WP (waterproof) is specifically designed for the MM400C, other two-wire lavalier microphones can be adapted to the MM400C using the WPMC-3 or WPMC-10 kits. A Switchcraft 850 connector (Lectrosonics P/N 21357) can be used in an emergency though it is not waterproof. (See Replacement Parts and Accessories.)

The equivalent input circuit wiring for the Mic Jack is shown below:

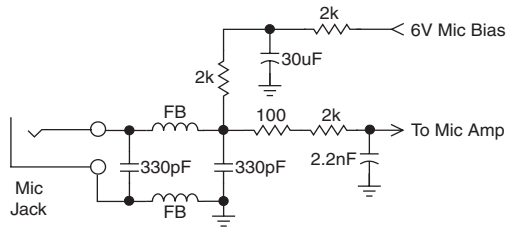

Audio Level

The Audio Level Control is used to adjust the audio input level from the microphone for proper modulation of the output signal from the transmitter.

Modulation LEDs

The two bicolor Modulation LEDs provide a visual indication of the audio signal level input from the microphone. These LEDs can glow either red or green to indicate modulation levels as shown in the following chart.

Signal Level	-20 LED	-10 LED
Less than -20 dB	○ Off	○ Off
-20 dB to -10 dB	● Green	○ Off
-10 dB to +0 dB	● Green	● Green
+0 dB to +10 dB	● Red	● Green
Greater than +10 db	● Red	● Red

When the Power ON/OFF Switch is configured for Audio Mute Mode, the -10 Modulation LED is also used to indicate if the transmitter is in an audio muted, or an unmuted condition. In Audio Mute Mode, if the Power ON/OFF switch is set to OFF, the transmitter remains powered up; however, the audio is muted and the -10 Modulation LED blinks green.

If the Power ON/OFF switch is set to ON and the switch is configured for Audio Mute Mode, -10 and -20 LEDs operate normally to indicate audio level.

Frequency Select Switches

Two 16-position rotary Frequency Select Switches are used to select the operating frequency, for setting Compatibility Modes and for configuring the Power ON/OFF switch.

The switches are accessed by loosening the retaining screw holding the cover plate, lifting the cover away from the housing and rotating it to expose the switches.

For setting the operating frequency, the left switch (1.6MHz) adjusts the operating frequency up or down in 1.6 MHz increments. The right switch (100kHz) adjusts the frequency up or down in 100 kHz increments. (See *Operating Instructions, Adjusting the Transmitter Frequency.*)

A sequence of Frequency Select Switch settings and Power ON/OFF toggles are used to set Compatibility Modes and for configuring the Power ON/OFF switch. (See *Operating Instructions, Setting Compatibility Modes and Power Switch Function Selection.*)

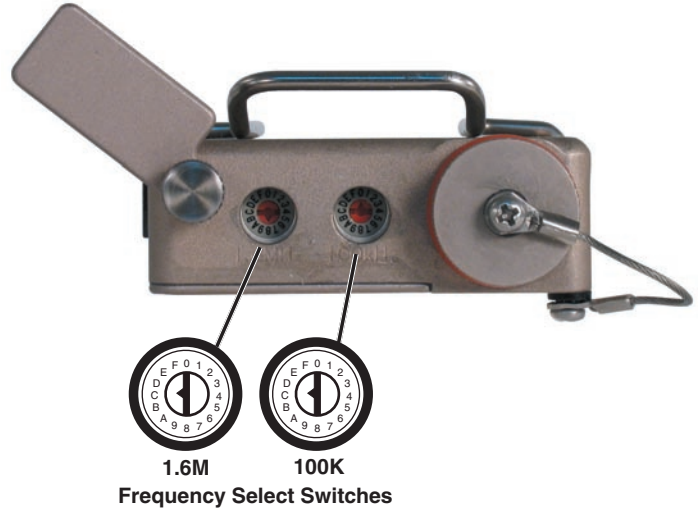

Antenna

The permanently-mounted, flexible steel cable antenna is cut to 1/4 wavelength of the center of the frequency block (the frequency range) of the transmitter.

Belt Clip

The belt clip may be removed for special applications by gently spreading the spring wire clip and pulling the ends out of the holes in the case. The clip can be installed in either the up or down position so that when the transmitter is worn, the antenna can be pointing up or down. Replacement belt clips are available. (See *Replacement Parts and Accessories.*)

Battery Installation

WARNING: Do not open battery compartment if unit is wet. Read "Preventing Internal Corrosion" on page 8 before proceeding.

The transmitter is powered by a standard lithium, NiMH or alkaline AA 1.5 volt battery. The battery status circuitry is designed for the voltage drop over the life of lithium batteries. While NiMH rechargeable batteries will work, they run down quite abruptly. Because of this, using the PWR LED to verify battery status not reliable with NiMH batteries. It is possible to track battery status using the Battery Timer function available in a number of Lectrosonics receivers. (Refer to your receiver manual to determine if this function is available.)

Alkaline batteries provide about 1.75 hours of operation with some warning. Lithium batteries can be used to provide over 6 hours of operation and provide about 30 minutes of warning as the LED turns red.

Note: Standard zinc-carbon batteries marked "heavy-duty" or "long-lasting" are not adequate.

To access the battery compartment, unscrew and remove the Battery Compartment Cover. Take note of the polarity marked on the battery case showing the location of the positive (+) and negative (-) terminals. The positive (+) battery terminal goes into the transmitter first. Screw the Battery Compartment Cover back into the transmitter body. If the battery is inserted incorrectly, the cover will not screw in easily and the unit will not work.

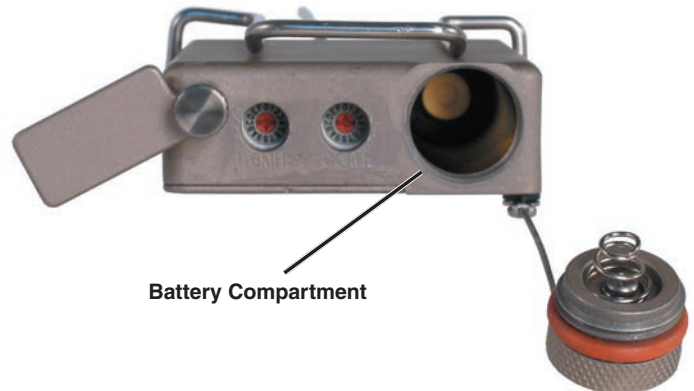

Operating Instructions

Selecting the Compatibility Mode

All Digital Hybrid receivers are capable of working with Lectrosonics MM400C transmitter, and by setting the proper Compatibility Mode, the unit will also work with 200 Series and 100 Series analog receivers, plus some other brands (contact the factory for details). In order to operate properly, the transmitter must be set to the operating mode of the matching receiver, which is easily done using a small screwdriver and a battery.

The following procedure assumes that the Power ON/OFF switch is configured for Normal Mode. If it has been configured for Audio Mute Mode, see *Power Switch Function Selection* to change the configuration to Normal Mode.

Note: The unit comes from the factory in the Digital Hybrid mode.

- 1) Set the audio controls for the corresponding receiver to minimum.
- 2) Install a good battery in the transmitter. Move the Power Switch to ON and observe the Modulation LEDs to determine the current Compatibility Mode. The -20 and -10 LEDs will blink simultaneously:
 - Once for 100 Series mode
 - Two times for 200 Series mode
 - Three times for "Other" receivers
 - Four times for 400 Series mode
 - Five times for IFB Series mode

- 3) Move the Power Switch to the OFF position.
- 4) Loosen the Frequency Switch Cover Plate Retaining Screen and rotate the cover to expose the Frequency Select Switches. With a small screwdriver (included with your unit), set the Frequency Select Switches to CC. (for Change, Change).

- 5) Power up the unit briefly – just long enough to watch the LED's glow and then turn



the transmitter Off.

- 6) Change the Frequency Select Switch settings to one of the following positions:
 - 100 Series mode: 1,1
 - 200 Series mode: 2,2
 - Mode 3: 3,3
 - 400 Series mode: 4,4
 - IFB Series mode: 5,5
- 7) Power up the unit briefly – just long enough to watch the LED's glow and then turn the transmitter Off.
- 8) Set the Frequency Select Switches to 0,0.
- 9) Turn on the transmitter and observe the Modulation LEDs to verify the compatibility mode for the unit has changed.

NOTE: Each time the transmitter is turned on, the Modulation LEDs will confirm the current operating mode with the number of blinks listed in Step 2. The mode setting will not change until reset with the procedure listed above.

Adjusting Transmitter Frequency

If you are experiencing interference from another signal on your operating frequency, you may need to change the operating frequency of your system. This is done through two Frequency Select Switches located under the Frequency Switch Cover Plate on the bottom of the transmitter case.

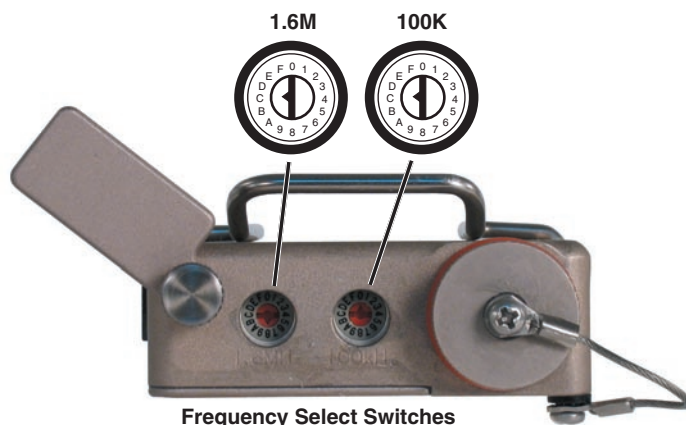

The left switch is for coarse frequency adjustment, and it increments the operating frequency in 1.6 MHz steps. The right switch is for fine frequency adjustment and it increments the operating frequency in 100 kHz steps. If you are using a 200 Series or 400 Series receiver, it is suggested to use the built in frequency spectrum scanning function on the associated receiver to find a clear channel. Turn the transmitter off and leave the receiver turned on. Scan across the frequency band to find a frequency where little or no RF activity is displayed. Set both the transmitter and the receiver to this new frequency. Turn on the transmitter to ensure the RF signal is strongly indicated at the receiver.

NOTE: All 400 Series (and a number of earlier receivers) offer a front panel LCDs that indicate the correct transmitter switch settings when locating clear channels. Use the scanning functions on these receivers to find a clear channel, then switch both the receiver and transmitter to the Frequency Select Switch settings indicated in the receiver's display.

If you are using a 100 Series receiver, turn off the transmitter and observe the RF LED on the front panel of the UCR100 receiver. If it flickers, or glows red, then adjust the UCR100's Frequency Select Switches up or down in 100 kHz increments until the RF LED extinguishes. Set the MM400C transmitter's Frequency Select Switches to the same settings. Turn on the transmitter and observe that the RF LED on the receiver glows brightly.

NOTE: Different voices will usually require different settings of the Audio Level Control, so check this adjustment as each new person uses the system. If several different people will be using the transmitter and there is not time to make the adjustment for each individual, adjust it for the loudest voice.

- Once the MM400C's audio gain has been set, the remaining components of the audio system can be energized and adjusted.

WARNING: The AUDIO LEVEL control should not be used to control the volume of your sound system or recorder levels. This gain adjustment matches the transmitter gain with the user's voice level and microphone positioning.

Attaching a Microphone and Adjusting Audio Levels

The front panel Modulation LEDs indicate limiter activity. (See chart.) Since the distortion introduced by the limiter is minimal and full modulation is assured, occasional forays into the red by the -10 LED is acceptable.

- Install a fresh battery.
 - Insert the watertight microphone plug into the Mic Jack and screw it in snugly.
- WARNING: Do not overtighten as this will distort the "O-ring" and allow moisture to enter the unit.**
- Mute the main sound system and rotate the Audio Level Control on the MM400C to maximum counter-clockwise (Off).
 - Set the Power ON/OFF switch to the ON position.
 - Position the microphone in the location where it will be used during in actual operation.
 - Observe the MM400C Modulation LEDs while speaking or singing into the microphone at the same voice level that will be used during the program. Gradually rotate the Audio Level Control clockwise until both LEDs glow green with the -20 dB occasional blinking red. This indicates full modulation and is the optimum setting for the transmitter's gain.

Signal Level	-20 LED	-10 LED
Less than -20 dB	○ Off	○ Off
-20 dB to -10 dB	● Green	○ Off
-10 dB to +0 dB	● Green	● Green
+0 dB to +10 dB	● Red	● Green
Greater than +10 db	● Red	● Red

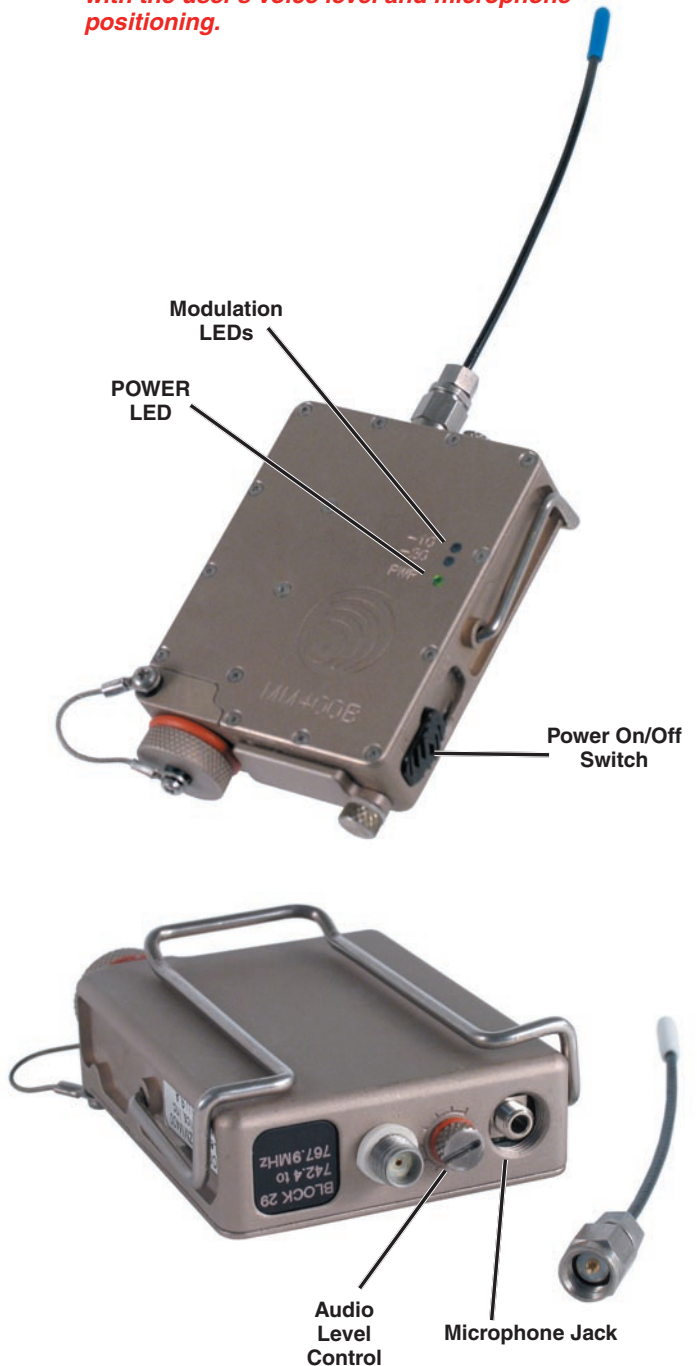

Power Switch Function Selection

The Power ON/OFF Switch can also be used as an audio mute switch. When used as an audio mute switch, the power switch causes the transmitter's audio to be muted when the Power ON/OFF switch is placed in the OFF position. The -10 Modulation LED blinks green to indicate that the transmitter is in Audio Mute Mode.

Function	Power Switch Position	
	ON	OFF
Normal, or Power Mode	Applies Power to Unit	Turns Unit Off
Audio Mute Mode	Turns On Audio	Mutes Audio

In Audio Mute Mode, the transmitter can still be turned off by toggling the Power ON/OFF switch rapidly. Turn the Power Switch ON then OFF three times (ending in the OFF position) within five seconds to initiate the power off sequence. The sequence is ON-OFF-ON-OFF-ON-OFF.

When the transmitter is powered up again, Audio Mute Mode will persist until the power switch function is changed.

Determine Power Switch Function Mode

- 1) If the transmitter is turned off, set the Power Switch ON and observe the Modulation LEDs.
- 2) After the power up sequence completes, place the POWER ON/OFF switch in the OFF position and observe the -10 Modulation LED.
- 3) If the PWR LED glows and the -10 Modulation LED blinks green, the Power Switch is in Audio Mute Mode. If the LEDs extinguish, the Power Switch is in Normal or Power Mode.

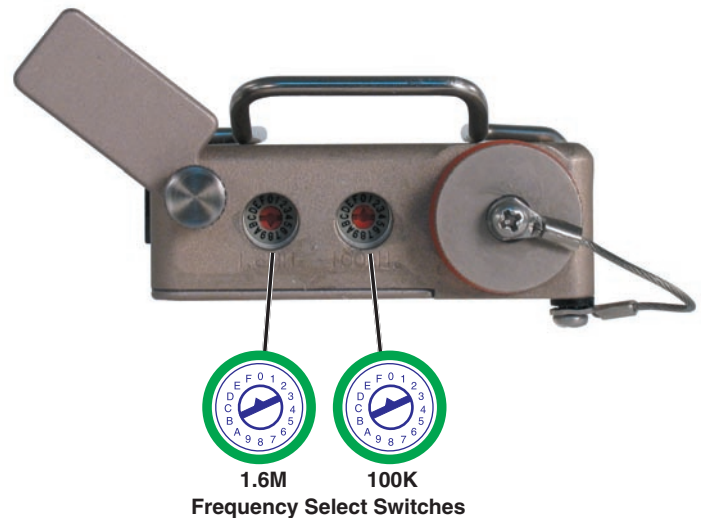

Changing Power Switch Function

- 1) Ensure the Power ON/OFF switch is in the OFF position.
- 2) Loosen the Frequency Switch Cover Plate Retaining Screw, pull it away from the transmitter body, then rotate it to expose the Frequency Select Switches.
- 3) With a small screwdriver (included with your unit), set the Frequency Select Switches to F,F.
- 4) Rapidly toggle the Power ON/OFF switch to ON then back to OFF.
- 5) Change the Frequency Select Switch settings to the following position:
Normal Mode: 1,1
Audio Mute Mode: 2,2.
- 5) Rapidly toggle the Power ON/OFF switch to ON then back to OFF.
- 6) Set the Frequency Select Switches to 0,0.
- 7) Rapidly toggle the Power ON/OFF switch to ON then back to OFF.
- 8) Turn on the transmitter. After the powerup sequence has completed, set the Power ON/OFF Switch to OFF and observe the -10 Modulation LED and the PWR LED.

If the Power ON/OFF switch is configured for Normal Mode, the -10 Modulation LED will go out and the PWR LED will blink red for a short period then go out indicating the transmitter has shut down.

If the Power ON/OFF switch is configured for Audio Mute Mode, the PWR LED continues to monitor battery condition while the -10 Modulation LED blinks green.

Replacing the Power Switch Magnet Housing Assembly

Although the Power Switch's Magnet Housing Assembly is designed to provide years of rugged use it may become inadvertently damaged or lost. Use the following procedure to install a new Magnet Housing Assembly.

- 1) If necessary, use a nonmetallic tool such as an "orange stick" to remove the damaged Magnet Housing Assembly and clean any debris from the Magnet Housing Assembly slot. Apply a small amount of petroleum jelly or white lithium grease to the area before inserting the new magnet assembly.

Warning: If you use something metallic, as illustrated in the example, use extreme caution not to scratch the finish. Breaching the finish may cause corrosion of the metal housing.

- 2) Notice that the Magnet Housing Assembly Slot has a wide spot in the middle. Place the new Magnet Housing Assembly in the slot so that one tab is in a small groove in one side of the slot.
- 3) Use a nonmetallic implement to snap the other side of the Magnet Housing Assembly into the slot.
- 4) Ensure a good battery is installed, then slide the new Power ON/OFF Switch to ON to verify that it is working properly.



First, center the switch in the slot in the housing so that the tabs will release through the wider openings.

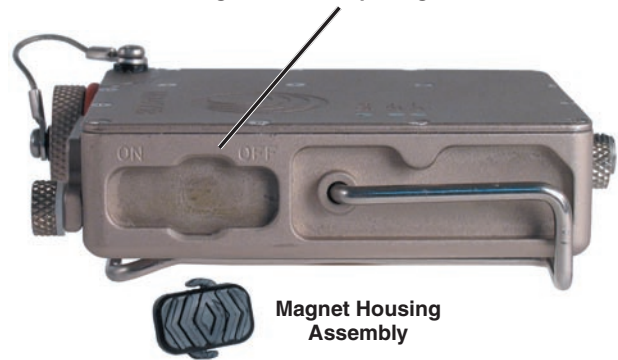

Microphone RF Bypassing

Some mics require RF protection to keep the radio signal from affecting the capsule, even though the transmitter input circuitry is already RF bypassed.

If the mic is wired as directed, and you are having difficulty with level, high noise, or poor frequency response; RF is likely to be the cause.

The best RF protection is accomplished by installing RF bypass capacitors at the mic capsule. If this is not possible, or if you are still having problems, capacitors can be installed on the mic wires inside the TA5F connector housing.

Install the capacitors as follows: Use 330 pF capacitors. Capacitors are available from Lectrosonics. Please specify the part number for the desired lead style.

2 WIRE MIC

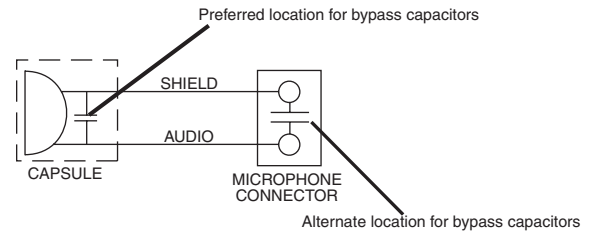

Leaded capacitors: P/N 15117

Leadless capacitors: P/N SCC330P

All Lectrosonics lavalier mics are already bypassed and do not need any additional capacitors installed for proper operation.

Replacement Parts and Accessories

Part/Model #	Description
26486	Replacement wire belt clip
21357	Non-watertight audio input plug
WPMC-3	Watertight plug kit - 3 pieces
WMPC-10	Watertight plug kit - 10 pieces
P1201-1	Switch Magnet Housing Assembly

UHF Transmitter Antenna Specifications

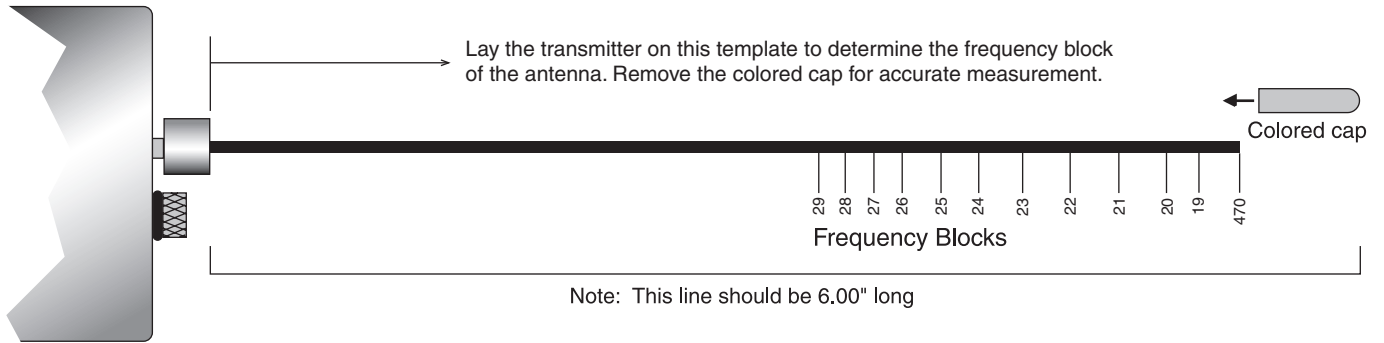

All Lectrosonic UHF transmitter antennas follow the color code specifications in the chart below to identify operating frequency block range. The frequency block range is labeled on the outside housing for each individual transmitter.

BLOCK	FREQUENCY RANGE	CAP COLOR	ANTENNA WHIP LENGTH
470	470.100 - 495.600	Black	5.37"
19	486.400 - 511.900	Black	5.16"
20	512.000 - 537.500	Black	4.98"
21	537.600 - 563.100	Brown	4.74"
22	563.200 - 588.700	Red	4.48"
23	588.800 - 614.300	Orange	4.24"
24	614.400 - 639.900	Yellow	4.01"
25	640.000 - 665.500	Green	3.81"
26	665.600 - 691.100	Blue	3.62"
27	691.200 - 716.700	Violet (Pink)	3.46"
28	716.800 - 742.300	Grey	3.31"
29	742.400 - 767.900	White	3.18"

Troubleshooting

Before going through the following chart, be sure that you have a good battery in the transmitter. It is important that you follow these steps in the sequence listed.

SYMPTOM

POSSIBLE CAUSE

TRANSMITTER PWR LED OFF

- 1) Battery is inserted backwards.
- 2) Battery is dead.
- 3) Power ON/OFF switch configured to Normal Mode and is set to OFF.

NO TRANSMITTER MODULATION LEDs

- 1) Verify Transmitter PWR LED is glowing.
- 2) Gain control turned all the way down.
- 3) Mic capsule is damaged or malfunctioning.
- 4) Mic cable damaged or mis-wired.

-10 MODULATION LED IS BLINKING GREEN AND RECEIVER HAS NO AUDIO

- 1) Power ON/OFF Switch is configured for Audio Mute Mode and the switch is in the OFF, or mute position. (See *Controls and Functions*.)

RECEIVER INDICATES NO RF

- 1) Transmitter not turned on.
- 2) Transmitter battery is dead.
- 3) Receiver antenna missing or improperly positioned.
- 4) Transmitter and receiver not on same frequency. Check switches/display on transmitter and receiver.
- 5) Operating range is too great.

NO SOUND (OR LOW SOUND LEVEL), RECEIVER INDICATES PROPER AUDIO MODULATION

- 1) Receiver output level set too low.
- 2) Receiver output is disconnected; cable is defective or connectors not wired correctly.
- 3) Sound system or recorder input is turned down.
- 4) Receiver/Transmitter compatibility mode mismatched.
- 5) Transmitter audio muted.

DISTORTED SOUND

- 1) Transmitter gain (audio level) is far too high. Check Modulation LEDs on transmitter and receiver as it is being used. (See *Operating Instructions, Attaching a Microphone and Adjusting Audio Levels*.)
- 2) Receiver output may be mismatched with the sound system or recorder input. Adjust output level on receiver to the correct level for the recorder, mixer or sound system.
- 3) Excessive wind noise or breath "pops." Reposition microphone and/or use a larger windscreen.
- 4) Transmitter is not set to same frequency as receiver. Check that frequency select switches on receiver and transmitter match.
- 5) Receiver/Transmitter compatibility mode mismatched.

HISS AND NOISE -- AUDIBLE DROPOUTS

- 1) Transmitter gain (audio level) far too low.
- 2) Receiver antenna missing or obstructed.
- 3) Operating range too great. Check RF level on receiver indicator.

EXCESSIVE FEEDBACK

- 1) Transmitter gain (audio level) too high. Check gain adjustment and/or reduce receiver output level.
- 2) Transmitter too close to speaker system.
- 3) Mic is too far from user's mouth.

Specifications and Features

Operating frequencies:

Block 470	470.100 - 495.600
Block 19	486.400 - 511.900
Block 20	512.000 - 537.500
Block 21	537.600 - 563.100
Block 22	563.200 - 588.700
Block 23	588.800 - 607.900 and 614.100 - 614.300
Block 24	614.400 - 639.900
Block 25	640.000 - 665.500
Block 26	665.600 - 691.100
Block 27	691.200 - 716.700
Block 28	716.800 - 742.300
Block 29	742.400 - 767.900

Frequency selection: 256 frequencies in 100 kHz steps

RF Power output: 100 mW (nominal)

Pilot tone: 25 to 32 kHz; 5 kHz deviation (in 400 Series Mode)

Frequency stability: $\pm 0.002\%$

Deviation: ± 75 kHz max. (in 400 Series Mode)

Spurious radiation: 60 dB below carrier

Equivalent input noise: -118 dBV, A-weighted

Input level: Nominal 2 mV to 300 mV, before limiting. Greater than 1.5V maximum, with limiting.

Input impedance: 2 kOhm

Input limiter: Soft limiter, >30 dB range

Gain control range: 43 dB; semi-log rotary control

Modulation indicators: Dual bicolor LEDs indicate modulation of -20, -10, 0, +10 dB referenced to full modulation.

Low frequency roll-off: -12 dB/octave; 70 Hz

Controls:

Front panel knob adjusts audio gain. Rotary switches on bottom panel adjust transmitter frequency.

Audio Frequency Response:

80 Hz to 20 kHz, +/-1dB, -3 dB @ 70 Hz (The audio is deliberately rolled off at 70 Hz using a 12 dB/octave filter. This filter cannot be disabled.)

Signal to Noise Ratio (dB): (overall system, 400 Series mode)

(Note: the dual envelope "soft" limiter provides exceptionally good handling of transients using variable attack and release time constants. The gradual onset of limiting in the design begins below full modulation, which reduces the measured figure for *SNR without limiting* by 4.5 dB)

	SmartNR	No Limiting	w/Limiting
OFF		103.5	108.0
NORMAL		107.0	111.5
FULL		108.5	113.0

Total Harmonic Distortion: 0.2% typical (400 Series mode)

Audio Input Jack: 2.5 mm Microjack (matches Switchcraft 850 Microplug)

Antenna: Detachable, flexible galvanized steel

with SMA connector. (50 Ohm antenna port also allows connection to test equipment.)

Battery: 1.5 Volt AA lithium recommended

Battery Life: 1.75 hours (alkaline); over 6 hours (lithium); 3.5 hours (2200 mAh) NiMH

Weight: 3.6 ozs. (102 grams) with lithium battery, no antenna

Overall Dimensions: 3.03 x 2 x 0.69 inches (not including microphone or antenna)

Emission Designator: 180KF3E
Specifications subject to change without notice.

The FCC requires that the following statement be included in this manual:

This device complies with FCC radiation exposure limits as set forth for an uncontrolled environment. This device should be installed and operated so that its antenna(s) are not co-located or operating in conjunction with any other antenna or transmitter.

Service and Repair

If your system malfunctions, you should attempt to correct or isolate the trouble before concluding that the equipment needs repair. Make sure you have followed the setup procedure and operating instructions. Check the interconnecting cables and then go through the **Troubleshooting** section in this manual.

We strongly recommend that you **do not** try to repair the equipment yourself and **do not** have the local repair shop attempt anything other than the simplest repair. If the repair is more complicated than a broken wire or loose connection, send the unit to the factory for repair and service. Don't attempt to adjust any controls inside the units. Once set at the factory, the various controls and trimmers do not drift with age or vibration and never require readjustment. **There are no adjustments inside that will make a malfunctioning unit start working.**

LECTROSONICS' Service Department is equipped and staffed to quickly repair your equipment. In warranty repairs are made at no charge in accordance with the terms of the warranty. Out-of-warranty repairs are charged at a modest flat rate plus parts and shipping. Since it takes almost as much time and effort to determine what is wrong as it does to make the repair, there is a charge for an exact quotation. We will be happy to quote approximate charges by phone for out-of-warranty repairs.

Returning Units for Repair

For timely service, please follow the steps below:

- A. DO NOT return equipment to the factory for repair without first contacting us by email or by phone. We need to know the nature of the problem, the model number and the serial number of the equipment. We also need a phone number where you can be reached 8 A.M. to 4 P.M. (U.S. Mountain Standard Time).
- B. After receiving your request, we will issue you a return authorization number (R.A.). This number will help speed your repair through our receiving and repair departments. The return authorization number must be clearly shown on the **outside** of the shipping container.
- C. Pack the equipment carefully and ship to us, shipping costs prepaid. If necessary, we can provide you with the proper packing materials. UPS is usually the best way to ship the units. Heavy units should be "double-boxed" for safe transport.
- D. We also strongly recommend that you insure the equipment, since we cannot be responsible for loss of or damage to equipment that you ship. Of course, we insure the equipment when we ship it back to you.

Lectrosonics USA:

Mailing address:

Lectrosonics, Inc.
PO Box 15900
Rio Rancho, NM 87174
USA

Shipping address:

Lectrosonics, Inc.
581 Laser Rd.
Rio Rancho, NM 87124
USA

Telephone:

(505) 892-4501
(800) 821-1121 Toll-free
(505) 892-6243 Fax

Web:

www.lectrosonics.com

E-mail:

sales@lectrosonics.com

Lectrosonics Canada:

Mailing Address:

49 Spadina Avenue,
Suite 303A
Toronto, Ontario M5V 2J1

Telephone:

(416) 596-2202
(877) 753-2876 Toll-free
(877-7LECTRO)
(416) 596-6648 Fax

E-mail:

Sales: colinb@lectrosonics.com
Service: joeb@lectrosonics.com

LIMITED ONE YEAR WARRANTY

The equipment is warranted for one year from date of purchase against defects in materials or workmanship provided it was purchased from an authorized dealer. This warranty does not cover equipment which has been abused or damaged by careless handling or shipping. This warranty does not apply to used or demonstrator equipment.

Should any defect develop, Lectrosonics, Inc. will, at our option, repair or replace any defective parts without charge for either parts or labor. If Lectrosonics, Inc. cannot correct the defect in your equipment, it will be replaced at no charge with a similar new item. Lectrosonics, Inc. will pay for the cost of returning your equipment to you.

This warranty applies only to items returned to Lectrosonics, Inc. or an authorized dealer, shipping costs prepaid, within one year from the date of purchase.

This Limited Warranty is governed by the laws of the State of New Mexico. It states the entire liability of Lectrosonics Inc. and the entire remedy of the purchaser for any breach of warranty as outlined above. NEITHER LECTROSONICS, INC. NOR ANYONE INVOLVED IN THE PRODUCTION OR DELIVERY OF THE EQUIPMENT SHALL BE LIABLE FOR ANY INDIRECT, SPECIAL, PUNITIVE, CONSEQUENTIAL, OR INCIDENTAL DAMAGES ARISING OUT OF THE USE OR INABILITY TO USE THIS EQUIPMENT EVEN IF LECTROSONICS, INC. HAS BEEN ADVISED OF THE POSSIBILITY OF SUCH DAMAGES. IN NO EVENT SHALL THE LIABILITY OF LECTROSONICS, INC. EXCEED THE PURCHASE PRICE OF ANY DEFECTIVE EQUIPMENT.

This warranty gives you specific legal rights. You may have additional legal rights which vary from state to state.

