

# SM

## DIGITAL HYBRID WIRELESS™ ULTRA-MINIATURE UHF BELT-PACK TRANSMITTER



## OPERATING INSTRUCTIONS

 **LECTROSONICS®**  
*Professional Audio Products Since 1971*

Rio Rancho, NM  
[www.lectrosonics.com](http://www.lectrosonics.com)

*The SM transmitter is FCC type accepted under Part 74: 536-608 MHz and 614-806 MHz.*

Thank you for selecting the Lectrosonics SM ultra-miniature transmitter. The unique design provides several distinct features for professional applications:

- Outstanding RF operating range
- Superb audio quality
- Ultra-lightweight, corrosion resistant housing
- Water resistant seals for use in damp environments
- Programmable compatibility modes for maximum versatility

The Digital Hybrid Wireless™ design (US Patent Pending) combines 24-bit digital audio with analog FM techniques resulting a system that has the same operating range as analog systems (plus the graceful failure at the limits of that range), the same spectral efficiency as analog systems, the same long battery life as analog systems, with the excellent audio found in digital systems.

The SM uses a standard Lectrosonics 5-pin type input jack for use with electret lavalier mic, dynamic mic, or line level signals. A water resistant control panel with LCD, membrane switches and multi-color LEDs make input gain adjustments and frequency and compatibility mode selection quick and accurate, without having to view the receiver. The battery compartment accepts an AA alkaline, lithium or NiMH battery. Plus, the SM is machined from a solid aluminum block to provide an extremely lightweight and rugged package. A special non-corrosive finish (the same one used on NASA space vehicles) resists salt water exposure and perspiration in extreme environments.

The DSP-based design offers backward compatibility with Lectrosonics 100 and 200 Series receivers, and some other brands of analog wireless receivers. Only the SM transmitter is covered in this manual. Companion receivers are covered in separate manuals.

## TABLE OF CONTENTS

<b>GENERAL TECHNICAL DESCRIPTION .....</b>	<b>4</b>
GENERAL .....	4
DIGITAL HYBRID WIRELESS™ TECHNOLOGY .....	4
NO PRE-EMPHASIS/DE-EMPHASIS .....	4
LOW FREQUENCY ROLL-OFF .....	5
INPUT LIMITER .....	5
DIGITAL SIGNAL PROCESSOR .....	5
MICROPROCESSOR, PLL AND VCO CIRCUITS .....	5
COMPATIBILITY MODES .....	5
PILOT TONE SQUELCH .....	5
CONTROL PANEL .....	5
WIDE-BAND DEVIATION .....	5
BATTERY LIFE .....	5
FREQUENCY AGILITY .....	5
CIRCULATOR/ISOLATOR .....	5
<b>CONTROLS AND FUNCTIONS .....</b>	<b>6</b>
LCD SCREEN .....	6
PWR LED .....	6
AUDIO INPUT JACK .....	6
MODULATION LEDES .....	6
AUDIO BUTTON .....	6
FREQ BUTTON .....	6
UP/DOWN ARROWS .....	7
ANTENNA .....	7
BATTERY COMPARTMENT AND THUMB SCREW .....	7
<b>SM SCREEN SELECTIONS .....</b>	<b>8</b>
FREQUENCY SCREEN .....	8
AUDIO SCREEN .....	8
COMPATIBILITY MODE SCREEN .....	8
LOCK/UNLOCK SCREEN .....	8
POWER OFF TIMER SCREEN .....	8
<b>BATTERY INSTALLATION .....</b>	<b>9</b>
<b>OPERATING INSTRUCTIONS .....</b>	<b>10</b>
POWER UP AND BOOT SEQUENCE .....	10
POWER DOWN .....	10
SELECTING THE COMPATIBILITY MODE .....	10
SETTING TRANSMITTER OPERATING FREQUENCY .....	11
ATTACHING A MICROPHONE AND ADJUSTING GAIN .....	11
LOCKING OR UNLOCKING THE CONTROL PANEL .....	12
<b>OPERATING NOTES .....</b>	<b>12</b>
<b>5-PIN INPUT JACK WIRING .....</b>	<b>13</b>
MICROPHONE RF BYPASSING .....	13
LINE LEVEL SIGNALS .....	14
WIRING HOOKUPS FOR DIFFERENT SOURCES .....	14
<b>TROUBLESHOOTING .....</b>	<b>15</b>
<b>SPECIFICATIONS AND FEATURES .....</b>	<b>16</b>
<b>SERVICE AND REPAIR .....</b>	<b>17</b>
<b>RETURNING UNITS FOR REPAIR .....</b>	<b>18</b>
<b>LIMITED ONE YEAR WARRANTY .....</b>	<b>20</b>

## GENERAL TECHNICAL DESCRIPTION

### GENERAL

The 400 system uses  $\pm 75$  kHz wide deviation for an extremely high signal to noise ratio. Switching power supplies provide constant voltages to the transmitter circuits from the beginning (1.5 Volts) to the end (0.85 Volts) of battery life, and an ultra low noise op amp is used as the input amplifier for quiet operation. It is gain protected with a wide range dual envelope input limiter which cleanly limits input signal peaks over 30 dB above full modulation.

*Note*

*The terms 400 Series and Digital Hybrid Wireless™ describe the same product line and are interchangeable.*

### DIGITAL HYBRID WIRELESS™ TECHNOLOGY\*

All wireless links suffer from channel noise to some degree, and all wireless microphone systems seek to minimize the impact of that noise on the desired signal. Conventional analog systems use compressors for enhanced dynamic range, at the cost of subtle artifacts (known as “pumping” and “breathing”). Wholly digital systems defeat the noise by sending the audio information in digital form, at the cost of some combination of power, bandwidth and resistance to interference.

Lectrosonics Digital Hybrid Wireless™ systems overcome channel noise in a dramatically new way, digitally encoding the audio in the transmitter and decoding it in the receiver, yet still sending the encoded information via an analog FM wireless link. This proprietary algorithm is not a digital implementation of an analog compressor but

a technique that can be accomplished only in the digital domain, even though the inputs and outputs are analog.

Channel noise still impacts received signal quality and will eventually overwhelm a receiver. Digital Hybrid Wireless™ simply encodes the signal to use a noisy channel as efficiently and robustly as possible, yielding audio performance that rivals that of wholly digital systems, without the power and bandwidth problems inherent in digital transmission.

Because it uses an analog FM link, Digital Hybrid Wireless™ enjoys all the benefits of conventional FM wireless systems, such as excellent range, efficient use of RF spectrum, and resistance to interference. However, unlike conventional FM systems, it does away with the analog compressor and its artifacts.

### NO PRE-EMPHASIS/DE-EMPHASIS

The Digital Hybrid Wireless™ design results in a signal-to-noise ratio high enough to preclude the need for conventional pre-emphasis (HF boost) in the transmitter and de-emphasis (HF roll off) in the receiver.

### LOW FREQUENCY ROLL-OFF

A 12 dB per octave low frequency roll-off is provided in the audio section, with the -3 dB point at 70 Hz. The actual roll-off frequency will vary somewhat according to the low frequency response of the mic capsule being used.

The low frequency roll-off is used to remove subsonic (or very low frequency) audio, often produced by air conditioning systems, automobile traffic and other sources

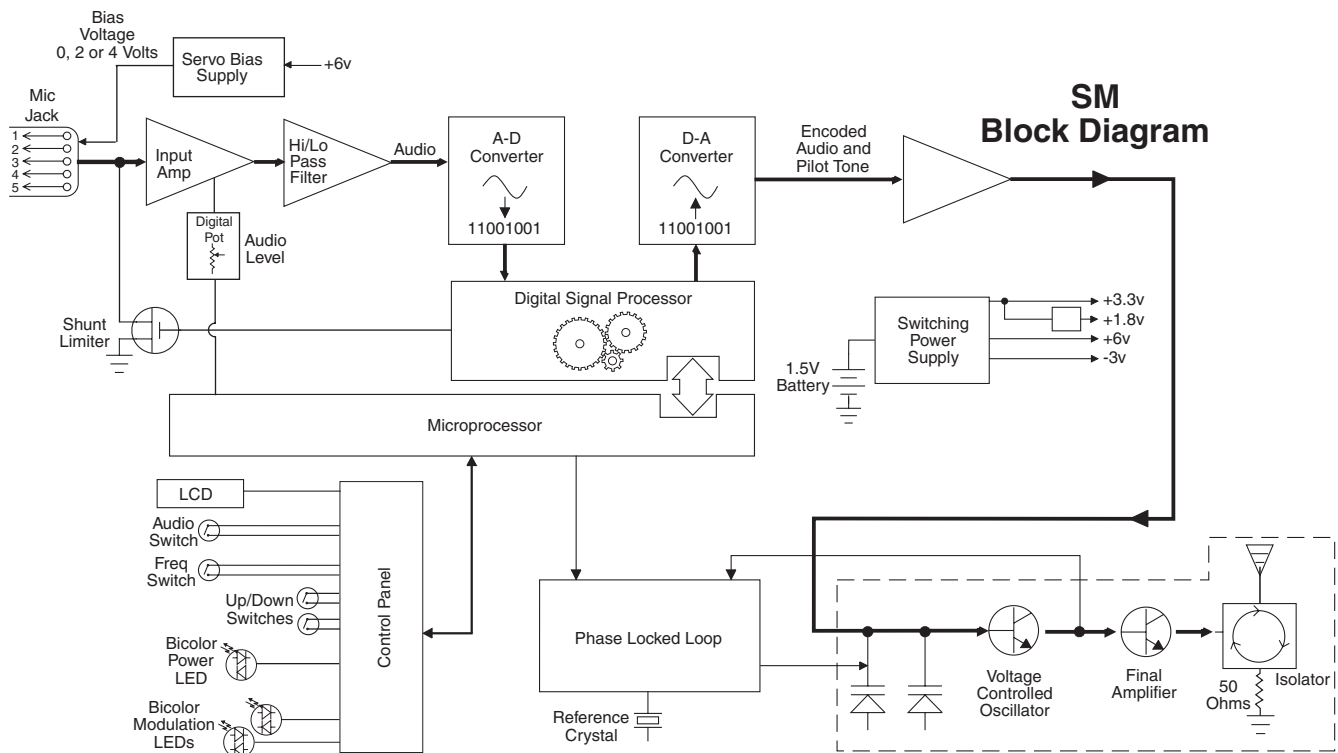

\*US Patent Pending

from the audio signal. Excessive low frequency content in the audio input can cause a variety of audio problems including driving the transmitter into limiting.

## INPUT LIMITER

A digitally-controlled analog audio limiter is employed just before the analog-to-digital converter. The limiter has a range of more than 30 dB for excellent overload protection. A dual release envelope makes the limiter acoustically transparent while maintaining low distortion. It can be thought of as two limiters in series, connected as a fast attack and release limiter followed by a slow attack and release limiter. The limiter recovers quickly from brief transients, so that its action is hidden from the listener, but recovers slowly from sustained high levels, to both keep audio distortion low and preserve short term dynamic changes.

Two bicolor LEDs indicate limiter activity. (See *Operating Instructions, Adjusting Audio Levels.*)

## DIGITAL SIGNAL PROCESSOR

The DSP encodes the digitized audio from the A-D Converter and adds an ultrasonic Pilot Tone to control the receiver's squelch (only in 400 Series, 200 Series and IFB Compatibility Modes with the Pilot Tone enabled – see *Pilot Tone Squelch*).

## MICROPROCESSOR, PLL AND VCO CIRCUITS

An 8-bit microprocessor monitors user command inputs from the Control Panel buttons and numerous other internal signals. It works intimately with the DSP to ensure the audio is encoded according to the selected Compatibility Mode and the correct pilot tone is added to the encoded signal. (See *Pilot Tone Squelch*.) It also drives the LCD display, controls the Pilot Tone, operates the PLL/VCO circuits.

## COMPATIBILITY MODES

The SM transmitter was designed to be compatible with Lectrosonics 400 Series receivers and will yield the best performance when doing so. However, due to the flexibility of digital signal processing, the SM is also able to operate with Lectrosonics 200 Series, Lectrosonics 100 Series, IFB and certain non-Lectrosonics receivers in special compatibility modes. (Contact the Lectrosonics Sales Department for a complete list of compatible receivers.)

## PILOT TONE SQUELCH

The Digital Hybrid Wireless™ system uses one of 256 different ultrasonic tones between 25 and 32 kHz, that modulate the carrier to operate the receiver squelch.

The pilot tone frequency is chosen according to which of the 256 channels has been selected via the Control Panel mounted FREQ switch. (See *SM Screen Selections.*) The pilot tone squelch system ensures the receiver will remain muted until it receives the pilot tone from the matching transmitter, even if a strong RF signal is present on the carrier frequency of the system. 400 Series Compatibility Mode extends this concept even further by insuring that all transmitters in a system have different pilot tone frequencies so that even spurious RF from the wrong transmitters can't open the receiver squelch.

## CONTROL PANEL

A waterproof control panel which includes four membrane switches and an LCD screen is used to change and control the operational settings, and also provide a visual feedback of overall system operation. (See *Controls and Functions.*)

## WIDE-BAND DEVIATION

A  $\pm 75$  kHz deviation improves the capture ratio, signal to noise ratio and AM rejection of a wireless system dramatically, compared to other designs that use 30 kHz to 40 kHz deviation. This combined with a full 100 mW of power output makes a significant improvement in signal to noise ratio and maximum operating range.

## BATTERY LIFE

Switching power supplies throughout the design allow about 4.5 hours of operation using a single AA lithium battery. An alkaline AA battery provides about 2 hours, and a NiMH AA battery provides about 3.5 hours of operation. The battery contacts are spring loaded to prevent "rattle" as the unit is handled.

## FREQUENCY AGILITY

The transmitter section uses a synthesized, frequency selectable main oscillator. The frequency is extremely stable over a wide temperature range and over time. Two membrane switches, located on the Control Panel, provide 256 frequencies in 100 kHz steps over a 25.5 MHz range.

## CIRCULATOR/ISOLATOR

The RF output circuit includes a one way circulator/isolator using a magnetically polarized ferrite. This device greatly reduces RF intermodulation produced when multiple transmitters are used at separations of less than five feet. It also provides additional RF output stage protection but is rarely seen in a wireless microphone transmitter due to its high cost.

## CONTROLS AND FUNCTIONS

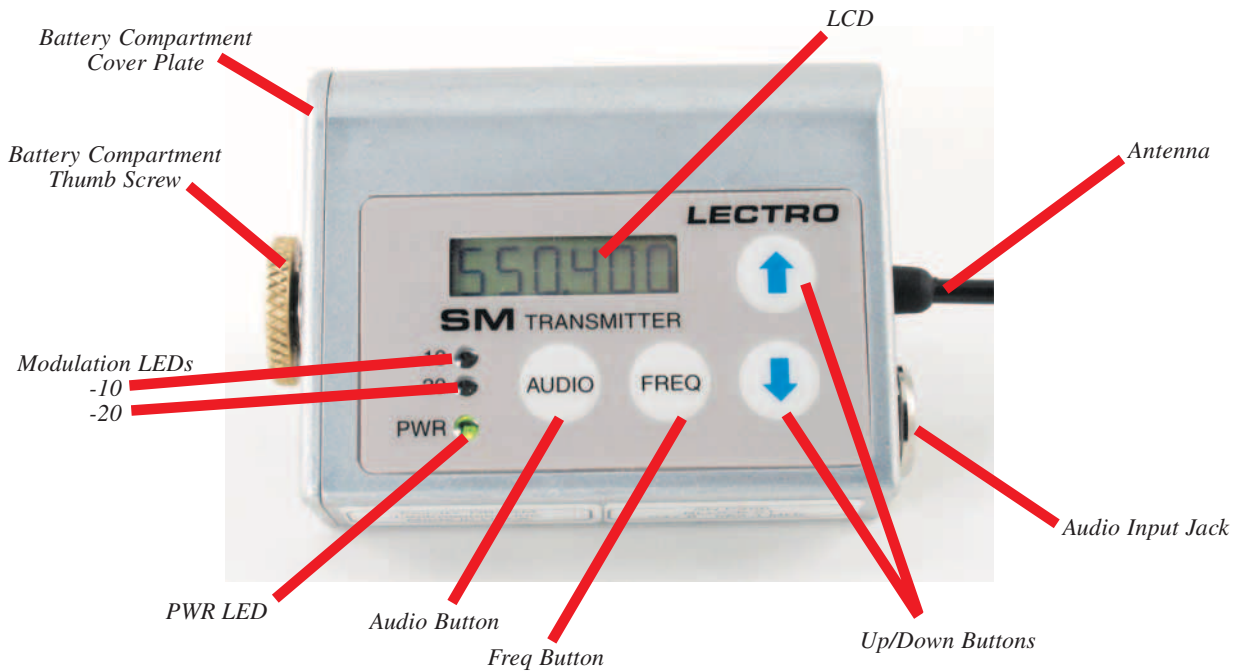

### LCD SCREEN

The LCD is a numeric-type Liquid Crystal Display used in conjunction with the AUDIO and FREQ buttons, and the UP and Down arrows, to configure the SM. (See SM SCREEN SELECTIONS.) It is also used with the Modulation and PWR LEDs to monitor system operation.

### PWR LED

The PWR LED glows green when the battery is good. The color changes to red when there is about 30 minutes of operation left with the recommended lithium battery. (An alkaline battery will have about 20 minutes of life left.) When the LED begins to flicker red, there are only a few minutes of life.

*Note*

*A NiMH battery will give little or no warning when it is depleted. If you wish to use NiMH batteries in the SM, we recommend trying fully charged batteries in the unit, noting the length of time that the batteries will run the unit and then using the battery timer feature available on most 400 Series receivers.*

A weak battery will sometimes cause the PWR LED to glow green immediately after being put in the unit, but will soon discharge to the point where the LED will go red or shut off completely.

### AUDIO INPUT JACK

The input on the SM accommodates virtually every lavalier, hand-held or shotgun microphone available. Different line level signals can also be accommodated. (See *LINE LEVEL SIGNALS* and *5-PIN INPUT JACK WIRING*.)

### MODULATION LEDS

The Modulation LEDs provide a visual indication of the input audio signal level from the microphone. These two bicolor LEDs can glow either red or green to indicate modulation levels.

Signal Level	-20 LED	-10 LED
Less than -20 dB	Off	Off
-20 dB to -10 dB	Green	Off
-10 dB to +0 dB	Green	Green
+0 dB to +10 dB	Red	Green
Greater than +10 dB	Red	Red

### AUDIO BUTTON

Pressing the AUDIO button alone causes the LCD to display the audio level setting (0 dB to 44 dB). This level is adjustable via the Up and Down arrows.

Simultaneously pressing the AUDIO button and FREQ button will power the transmitter on or off.

### FREQ BUTTON

The SM provides 256 individual frequencies, in 100 kHz increments, across a 25.5 MHz frequency block. The FREQ Button toggles the LCD between displaying the actual operating frequency in MHz or a two-digit hexadecimal number that corresponds to the equivalent Lectrosonics Frequency Switch Setting.

Simultaneously pressing the **FREQ** button and **AUDIO** button will power the transmitter on and off.

### **UP/DOWN ARROWS**

The Up and Down arrows are used to select the operating frequency, adjust the audio level, or set the Compatibility Mode.

Pressing both arrows simultaneously locks the control panel buttons so they can only be used to display current settings. A capital “L” appears in the display to indicate the controls are locked.

To unlock the control panel, press both arrows again. “unL” appears in the display to indicate that the control panel is unlocked.

The lock status, locked or unlocked, is preserved even if the unit is shut off.

### **ANTENNA**

The fixed flexible cable antenna is supplied with the transmitter. This antenna is cut to the 1/4 wavelength of the center of the frequency block (the frequency range) of the transmitter.

### **BATTERY COMPARTMENT AND THUMB SCREW**

The large knurled brass thumbscrew is used to release or secure the Battery Compartment Cover Plate, allowing access to the battery.

## SM SCREEN SELECTIONS



Five screens are used to set up and operate the SM. These screens are used to set the operating frequency, adjust the audio modulation level, select the Compatibility Mode, lock or unlock the control panel and power down the transmitter

### FREQUENCY SCREEN

The Frequency Screen displays the operating frequency in MHz when the system is initially turned on. Pressing the FREQ button displays the operating frequency as a two-digit hexadecimal number that corresponds to the equivalent Lectrosonics Frequency Switch Setting.

644.400

CH 2C

### AUDIO SCREEN

Pressing the AUDIO button during normal operation displays the current audio input level setting.

Aud 12

### COMPATIBILITY MODE SCREEN

Holding down the Up arrow button while powering up the SM opens the Compatibility Mode screen. By using the Up or Down arrow buttons, the user can select one of five compatibility modes:

CP 400

- 400 - This is the factory default setting and works with all Lectrosonics 400 Series Digital Hybrid Wireless™ receivers. This mode offers the best audio quality.
- 200 - This mode works with all Lectrosonics 200 Series compatible receivers.
- 100 - This mode works with all Lectrosonics 100 Series compatible receivers.

- 3 - (Mode 3) This mode works with a number of non-Lectrosonics analog receivers. Contact the company for a list of compatible receivers.
- IFB - This mode works with all Lectrosonics IFB compatible receivers.

Pressing either the AUDIO or FREQ button leaves this screen and accesses the screen associated with the button that was pushed.

### LOCK/UNLOCK SCREEN

Simultaneously pressing both the Up and Down arrow buttons during normal operation toggles between locking and unlocking the front panel controls. (If the control panel was locked when the buttons are pushed, it will toggle to the unlocked condition.)

L

*Control Panel Locked*

unL

*Control Panel Unlocked*

The LCD will display the Locked/Unlocked condition while the arrow buttons are pressed, then revert back to the previous screen when either button is released.

While the AUDIO and FREQ buttons can be used to display current settings, any attempt to change a setting by pressing either the Up or Down arrow button when the Control Panel is locked will temporarily display an "L" in the LCD.

### POWER OFF TIMER SCREEN

Simultaneously holding the AUDIO and FREQ buttons while the unit is operating displays the Power Off Timer screen. The screen counts down from three to zero. Releasing either button prior to the Power Off Timer screen indicating zero returns the unit to normal operation and displays the previous screen.

oFF . . . 3

*Initial Power Off Timer Screen*

oFF . . . 0

*End Power Off Timer Screen*

The unit turns off only when the Power Off Timer reaches zero and the AUDIO and FREQ buttons are released.



## BATTERY INSTALLATION

The transmitter is powered by a standard AA 1.5 volt battery. We recommend using lithium battery for longest life. Lithium batteries provide over 4.5 hours of operation at room temperature.

*Note*

*Standard zinc-carbon batteries marked “heavy-duty” or “long-lasting” are not adequate.*

The battery status circuitry is designed for the voltage drop over the life of lithium batteries.

To install a new battery:

1. Turn the Battery Cover Plate Thumbscrew counter-clockwise, open the battery compartment and remove any old battery.
2. Insert the new battery into the SM housing. Take note of the polarity marked on the case showing the location of the positive (+) and negative (-) terminals. The positive (+) battery terminal goes into the transmitter first.
3. Replace the Battery Cover Plate and tighten the Battery Cover Plate Thumbscrew.

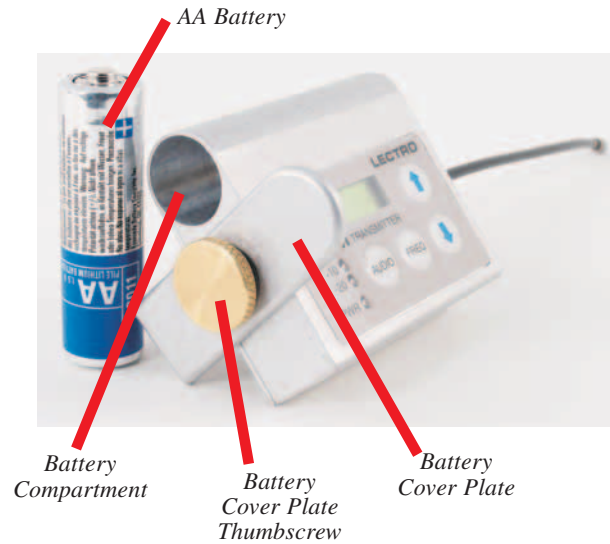

## OPERATING INSTRUCTIONS

### POWER UP AND BOOT SEQUENCE

- 1) Ensure that a good battery is installed in the unit. (See *Battery Installation*.)
- 2) Simultaneously press the AUDIO and FREQ buttons. As the unit turns on, the Modulation LEDs and PWR LED all glow red, then they all glow green. Then, they revert to normal operation, i.e., the Modulation LEDs glow according to the AUDIO level setting and the PWR LED glows green (providing the battery is in good condition).

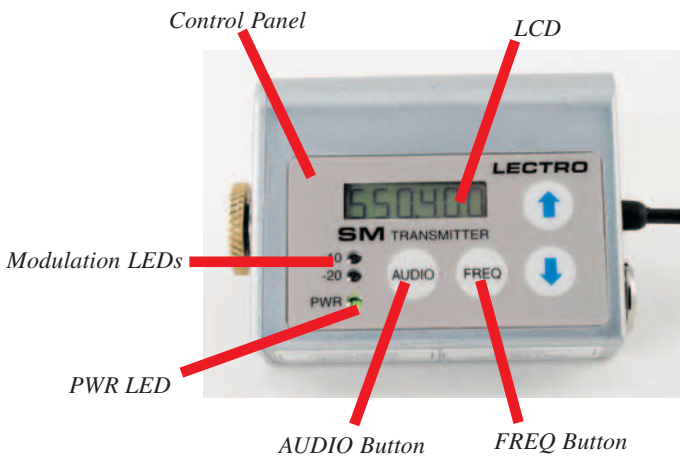

The LCD displays a bootup sequence which consists of four screens:

Company Name:	Lectro
Frequency Block (bXX) and Firmware Version (rX.X):	b21r1.1 (typ)
Compatibility Mode:	CP 400 (typ)
Frequency:	550.300 (typ)

### POWER DOWN

- 1) Simultaneously press and hold the AUDIO and FREQ buttons while observing that the word "Off" appears in the LCD along with a counter.
- 2) When the counter reaches "0", release the AUDIO and FREQ buttons to turn off the unit.



*Initial Power Off Timer Screen*



*End Power Off Timer Screen*

*Note*

If the AUDIO and FREQ buttons are released before the counter reaches "0," the unit will not turn off. Instead, it will stay energized and the display will return to the previous screen.

### SELECTING THE COMPATIBILITY MODE

All Digital Hybrid Wireless™ receivers are capable of working with the Lectrosonics SM transmitter. By selecting the proper compatibility mode, the SM will also work

with 200 Series, 100 Series and IFB analog receivers, plus some other analog wireless receivers (contact the factory for details). Setting the Compatibility Mode of the transmitter to match the receiver is easily done via the Control Panel.

*Note*

The unit comes from the factory configured as a 400 Series transmitter.

- 1) Set the receiver's audio controls to minimum.
- 2) Power up the SM and observe the Boot Sequence. If the Compatibility Mode for the SM does not match the corresponding receiver, then power off the SM transmitter.

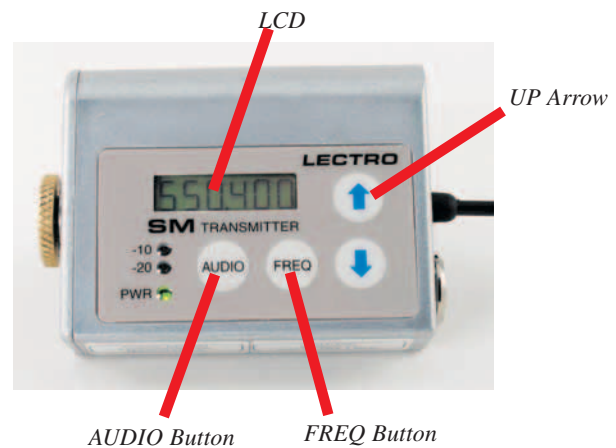

- 3) From a power off condition, hold down the Up arrow, then simultaneously press the AUDIO and FREQ buttons.
- 4) The LCD will display the current Compatibility Mode. Use the Up or Down arrow buttons to reset the Compatibility Mode to match the corresponding receiver.



*400 Series or Digital Hybrid Wireless™ Compatibility Mode*

The following Compatibility Modes are available:

- |  |        |
|--|--------|
| • 100 Series mode:                     | CP 100 |
| • 200 Series mode:                     | CP 200 |
| • Mode 3 (Contact dealer for details): | CP 3   |
| • 400 Series mode:                     | CP 400 |
| • IFB Series mode:                     | CP IFB |

- 5) Press the AUDIO or FREQ to exit this function. The Compatibility Mode selected in Step 4 will be the current Compatibility Mode until reset using this procedure.

### SETTING TRANSMITTER OPERATING FREQUENCY

The Operating Frequency of the SM can be displayed either in MHz or as a two-digit hexadecimal number.

(See *Controls and Functions, Frequency Screen.*) Use the following procedure to change the Operating Frequency of the SM transmitter:

- 1) If the LCD is displaying something other than the Frequency Screen, press the **FREQ** button on the SM Control Panel to enter the Frequency Screen.

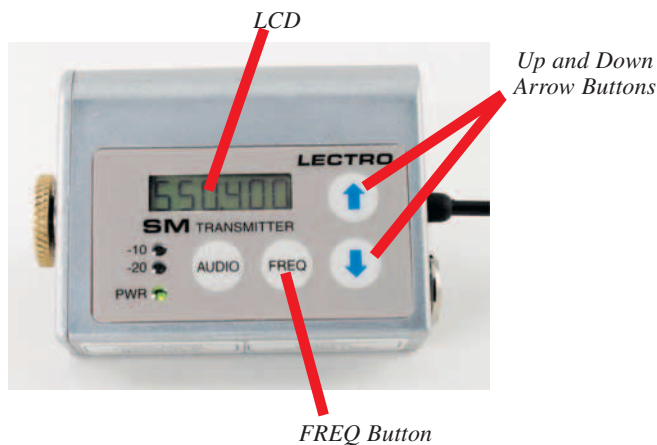

*Note*

The default is to display the operating frequency in MHz. Pressing the **FREQ** button again displays the operating frequency as a two-digit hexadecimal number that corresponds the equivalent Lectrosonics Frequency Switch Setting.

- 2) Use the Up or Down arrow buttons to move the operating frequency up or down in 100 kHz increments from the current setting.

*Note*

The operating frequency displayed on the LCD wraps as it reaches the upper or lower end of its range. Thus, if you intend to move the operating frequency from the lower end of the range to the upper end, it may be faster to do this by using the Down arrow until the frequency wraps to the upper end.

Most Lectrosonics receivers indicate the operating frequency both in MHz and as a two digit hexadecimal number.

This conforms to the Lectrosonics tradition of setting the operating frequency using two 16-position rotary switches. The SM offers the ability to set the operating frequency in a similar manner. Pressing the **FREQ** button while the LCD displays the operating frequency in MHz will change the display to show the equivalent two-digit hexadecimal

**644.400**

*Frequency displayed in MHz*

**CH 2C**

*Frequency displayed as two-digit hexadecimal number*

frequency select switch setting. Simply use the Up or Down arrow to increase or decrease the operating frequency. Pressing the **FREQ** button will toggle the display back to MHz.

## ATTACHING A MICROPHONE AND ADJUSTING GAIN

The front panel Modulation LEDs indicate limiter activity. (See chart below.) Once set, the transmitter's audio level setting **should not** be used to control the volume of your sound system or recorder levels. This gain adjustment matches the transmitter gain with the microphone's output level, the user's voice level and the microphone's position.

*Note*

Different voices will usually require different settings of the **AUDIO** control, so check this adjustment as each new person uses the system. If several different people will be using the transmitter and there is not time to make the adjustment for each individual, adjust it for the loudest voice.

- 1) Mute the main sound system, then insert the microphone plug into the input jack, aligning the pins and ensuring that the connector locks.
- 2) Turn on the transmitter and press the **AUDIO** button. (It is not necessary to wait until the Boot Sequence is complete before pressing the **AUDIO** button.)

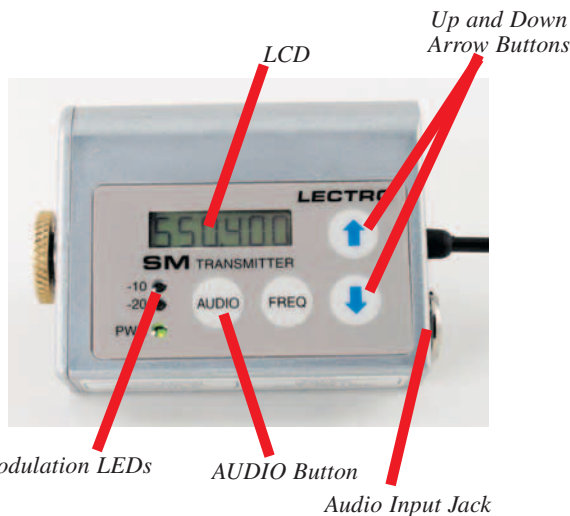

*Modulation LEDs*

*AUDIO Button*

*Audio Input Jack*

- 3) Position the microphone in the location where it will be used in actual operation.
- 4) Observe the SM Modulation LEDs while speaking or singing into the microphone at the same voice level that will be used during the program. Press the Up or Down arrow buttons until the both the -20 and -10 LEDs glow green, with the -10 LED occasionally flickering red. (-10 dB to +0 dB Signal Level

as show in the chart below with only occasional forays into the +0 dB to +10 dB range.)

Signal Level	-20 LED	-10 LED
Less than -20 dB	Off	Off
-20 dB to -10 dB	Green	Off
-10 dB to +0 dB	Green	Green
+0 dB to +10 dB	Red	Green
Greater than +10 dB	Red	Red

Setting the audio level to high reduces the dynamic range of if the audio signal. Setting the audio level to low may cause hiss and noise in the audio.

- 5) Once the SM's audio gain has been set, the remaining components of the audio system can be energized and adjusted.

## LOCKING OR UNLOCKING THE CONTROL PANEL

The Lock/Unlock function insures against unwanted operational changes to the SM during normal operation.

*Note*

*The Locked/Unlocked status is non-volatile and is preserved even if the unit is turned off.*

- 1) Ensure the SM setup is complete (operating frequency, Compatibility Mode, audio level, etc.).
- 2) Simultaneously press both the Up and Down arrow buttons. An "L" is displayed on the LCD. The LCD will return to the previous display when these buttons are released.



*Control Panel Locked*

- 3) To Unlock the Control Panel, repeat Step 4. A "unL" is displayed on the LCD.



*Control Panel Unlocked*

## 5-PIN INPUT JACK WIRING

The wiring diagrams included in this section represent the basic wiring necessary for the most common types of microphones and other audio inputs. Some microphones may require extra jumpers or a slight variation on the diagrams shown.

It's virtually impossible to keep completely up to date on changes that other manufacturers make to their products. It is possible that you may encounter a microphone that differs from these instructions. If this occurs please call our toll-free number listed under Service and Repair in this manual or visit our web site at:

<http://www.lectrosonics.com>

When used on a wireless transmitter, the microphone element is in the proximity of the RF coming from the transmitter. The nature of electret microphones makes them sensitive to RF, which can cause problems with the microphone/transmitter compatibility. If the electret microphone is not designed properly for use with wireless transmitters, it may be necessary to install a chip capacitor in the mic capsule or connector to block the RF from entering the electret capsule. (See *RF Bypassing*.)

The Audio Input Jack for the SM is wired as shown below:

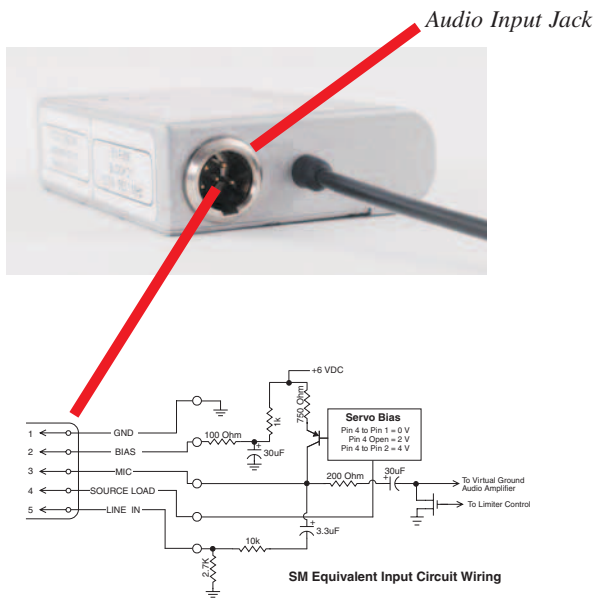

- PIN 1** Shield (ground) for positive biased electret lavalier microphones. Shield (ground) for dynamic microphones and line level inputs.
- PIN 2** Bias voltage source for positive biased electret lavalier microphones.
- PIN 3** Low impedance microphone level input for dynamic microphones. Also accepts hand-held

electret microphones provided the microphone has its own built-in battery.

- PIN 4** Bias voltage selector for Pin 3. Pin 3 voltage (0, 2 or 4 volts) depends on Pin 4 connection.

Pin 4 tied to Pin 1: 0 V  
 Pin 4 Open: 2 V  
 Pin 4 to Pin 2: 4 V

- PIN 5** High impedance, line level input for tape decks, mixer outputs, musical instruments, etc.

### MICROPHONE RF BYPASSING

Some mics require RF protection to keep the radio signal from affecting the capsule, even though the transmitter input circuitry is already RF bypassed (see schematic diagram).

If the mic is wired as directed, and you are having difficulty with squealing, high noise, or poor frequency response; RF is likely to be the cause.

The best RF protection is accomplished by installing RF bypass capacitors at the mic capsule. If this is not possible, or if you are still having problems, capacitors

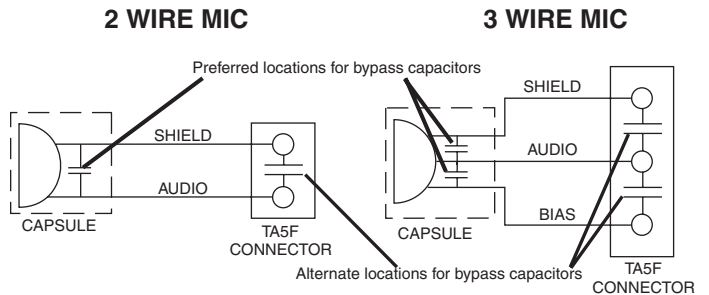

can be installed on the mic pins inside the TA5F connector housing.

Install the capacitors as follows: Use 330 pF capacitors. Capacitors are available from Lectrosonics. Please specify the part number for the desired lead style.

Leaded capacitors: P/N 15117  
 Leadless capacitors: P/N SCC330P

All Lectrosonics lavalier mics are already bypassed and do not need any additional capacitors installed for proper operation.

### LINE LEVEL SIGNALS

The normal hookup for line level signals is: Signal Hot to pin 5, Signal Gnd to pin 1 and pin 4 jumped to pin 1. This allows signal levels up to 3V RMS to be applied without limiting.

If more headroom is needed, insert a 100k resistor in series with pin 5. Put this resistor inside the TA5F connector to minimize noise pickup.

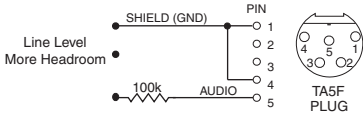
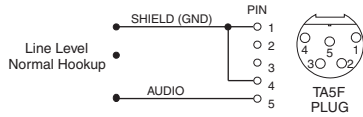

### WIRING HOOKUPS FOR DIFFERENT SOURCES

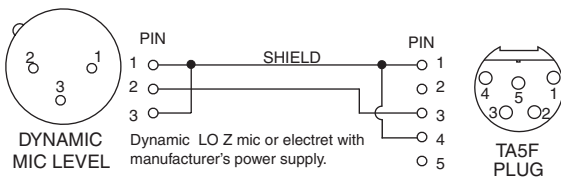
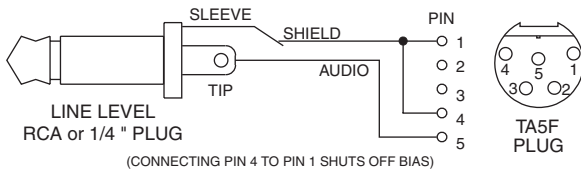
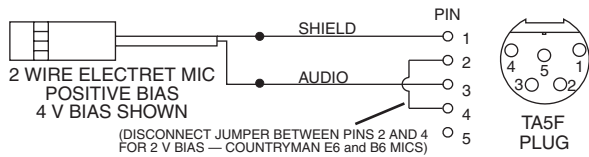
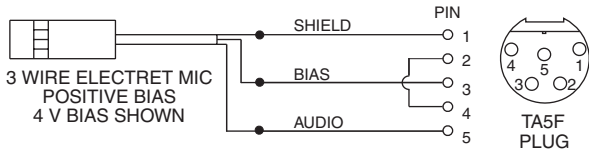

## TROUBLESHOOTING

Before going through the following chart, be sure that you have a good battery in the transmitter. It is important that you follow these steps in the sequence listed.

SYMPTOM	POSSIBLE CAUSE
<b>TRANSMITTER PWR LED OFF</b>	<ol style="list-style-type: none"> <li>1) Battery is inserted backwards.</li> <li>2) Battery is dead.</li> <li>3) Transmitter not powered up. (See <i>Operating Instructions, Power UP and Boot Sequence.</i>)</li> </ol>
<b>NO TRANSMITTER MODULATION LEDs</b>	<ol style="list-style-type: none"> <li>1) Gain control set to minimum.</li> <li>2) Battery is in backwards. Check PWR LED.</li> <li>3) Mic capsule is damaged or malfunctioning.</li> <li>4) Mic cable damaged or mis-wired.</li> </ol>
<b>RECEIVER RF INDICATOR OFF</b>	<ol style="list-style-type: none"> <li>1) Transmitter not turned on.</li> <li>2) Transmitter battery is dead.</li> <li>3) Receiver antenna missing or improperly positioned.</li> <li>4) Transmitter and receiver not on same frequency. Check switches/display on transmitter and receiver.</li> <li>5) Transmitter and receiver not on same frequency block.</li> <li>6) Operating range is too great.</li> <li>7) Defective transmitter antenna.</li> </ol>
<b>NO SOUND (OR LOW SOUND LEVEL), RECEIVER INDICATES PROPER AUDIO MODULATION</b>	<ol style="list-style-type: none"> <li>1) Receiver output level set too low.</li> <li>2) Receiver output disconnected, or cable defective or mis-wired.</li> <li>3) Sound system or recorder input is turned down.</li> </ol>
<b>DISTORTED SOUND</b>	<ol style="list-style-type: none"> <li>1) Transmitter gain (audio level) is far too high. Check SM Modulation LEDs and receiver audio levels as SM is being used.</li> <li>2) Receiver output may be mis-matched with the sound system or recorder input. Adjust output level on receiver to the correct level for the recorder, mixer or sound system. (Use the receiver's Tone function to check level settings.)</li> <li>3) Excessive wind noise or breath "pops." Reposition microphone and/or use a larger windscreen.</li> <li>4) Transmitter is not set to same frequency as receiver. Check that operating frequency on receiver and transmitter match.</li> <li>5) Receiver/Transmitter Compatibility Mode mismatched.</li> </ol>
<b>HISS AND NOISE -- AUDIBLE DROPOUTS</b>	<ol style="list-style-type: none"> <li>1) Transmitter gain (audio level) far too low.</li> <li>2) Receiver antenna missing or obstructed.</li> <li>3) Transmitter antenna missing.</li> <li>4) Operating range too great.</li> <li>5) Signal interference. Turn off transmitter. If receiver's signal strength indicator does not drop to nearly zero, this indicates an interfering signal may be the problem. Try a different operating frequency.</li> </ol>
<b>EXCESSIVE FEEDBACK</b>	<ol style="list-style-type: none"> <li>1) Transmitter gain (audio level) too high. Check gain adjustment and/or reduce receiver output level.</li> <li>2) Talent standing too close to speaker system.</li> <li>3) Mic is too far from user's mouth.</li> </ol>
<b>"L" APPEARS IN DISPLAY WHEN ANY BUTTON IS PRESSED</b>	<ol style="list-style-type: none"> <li>1) Control Panel is locked. (See <i>Operating Instructions, Locking and Unlocking the Control Panel.</i>)</li> </ol>

## SPECIFICATIONS AND FEATURES

<b>Operating frequencies:</b>	Block 21 537.600 - 563.100 Block 22 563.200 - 588.700 Block 23 588.800 - 607.900 and 614.100 - 614.300 Block 24 614.400 - 639.900 Block 25 640.000 - 665.500 Block 26 665.600 - 691.100 Block 27 691.200 - 716.700 Block 28 716.800 - 742.300 Block 29 742.400 - 767.900												
<b>Frequency selection:</b>	256 frequencies in 100 kHz steps per 25.5 MHz wide block												
<b>Channel Spacing:</b>	100 kHz												
<b>Frequency adjustment:</b>	Control panel mounted membrane switches												
<b>RF Power output:</b>	100 mW (nominal)												
<b>Compatibility Modes:</b>	There are five- Digital Hybrid Wireless™ (400 Series), 200 Series, 100 Series, Mode 3 (other analog) and IFB												
<b>Pilot tone:</b>	25 to 32 kHz; 5 kHz deviation (in 400 Series Mode)												
<b>Frequency stability:</b>	± 0.002%												
<b>Deviation:</b>	± 75 kHz max. (in 400 Series Mode)												
<b>Spurious radiation:</b>	60 dB below carrier												
<b>Equivalent input noise:</b>	-125 dBV, A-weighted												
<b>Input level:</b>	Nominal 2 mV to 300 mV, before limiting. Greater than 1.5V maximum, with limiting.												
<b>Input impedance:</b>	2 kOhm												
<b>Input limiter:</b>	Soft limiter, >30 dB range												
<b>Gain control range:</b>	40 dB; panel mounted membrane switches												
<b>Modulation indicators:</b>	Dual bicolor LEDs indicate modulation of -20, -10, 0, +10 dB referenced to full modulation.												
<b>Low frequency roll-off:</b>	-12 dB/octave; 70 Hz												
<b>Controls:</b>	Control panel with LCD and four membrane switches.												
<b>Audio Frequency Response:</b>	70 Hz to 20 kHz, +/-1dB (The audio is deliberately rolled off at 70 Hz using a 12 dB/octave filter. This filter cannot be disabled.)												
<b>Signal to Noise Ratio (dB): (overall system, 400 Series mode)</b>	<table border="1"> <thead> <tr> <th>SmartNR</th> <th>No Limiting</th> <th>W/ Limiting</th> </tr> </thead> <tbody> <tr> <td>OFF</td> <td>103.5</td> <td>108.5</td> </tr> <tr> <td>NORMAL</td> <td>107.0</td> <td>111.5</td> </tr> <tr> <td>FULL</td> <td>108.5</td> <td>113.0</td> </tr> </tbody> </table> <p>(Note: The dual envelope "soft" limiter provides exceptionally good handling of transients using variable attack and release time constants. The gradual onset of limiting in the design begins below full modulation, which reduces the measured figure for SNR without limiting by 4.5 dB)</p>	SmartNR	No Limiting	W/ Limiting	OFF	103.5	108.5	NORMAL	107.0	111.5	FULL	108.5	113.0
SmartNR	No Limiting	W/ Limiting											
OFF	103.5	108.5											
NORMAL	107.0	111.5											
FULL	108.5	113.0											
<b>Total Harmonic Distortion:</b>	0.2% typical (400 Series mode)												
<b>Audio Input Jack:</b>	Switchcraft 5-pin locking (TA5F)												
<b>Antenna:</b>	Fixed, flexible wire.												
<b>Battery:</b>	1.5 Volt AA lithium recommended												
<b>Battery Life:</b>	2 hours (alkaline); 4.5 hours (lithium)												
<b>Weight:</b>	3.6 ozs. (102 grams) with lithium battery												
<b>Overall Dimensions:</b>	3.03 x 2 x 0.69 inches (not including microphone)												

**Emission Designator:** UNK AT THIS TIME  
Specifications subject to change without notice.

The FCC requires that the following statement be included in this manual:

This device complies with FCC radiation exposure limits as set forth for an uncontrolled environment. This device should be installed and operated so that its antenna(s) are not co-located or operating in conjunction with any other antenna or transmitter.



## SERVICE AND REPAIR

If your system malfunctions, you should attempt to correct or isolate the trouble before concluding that the equipment needs repair. Make sure you have followed the setup procedure and operating instructions. Verify the integrity of the interconnecting cords and then go through the TROUBLESHOOTING section in the manual.

We strongly recommend that you **do not** try to repair the equipment yourself and **do not** have the local repair shop attempt anything other than the simplest repair. If the repair is more complicated than a broken wire or loose connection, send the unit to the factory for repair and service. Don't attempt to adjust any controls inside the units. Once set at the factory, the various controls and trimmers do not drift with age or vibration and never require readjustment. **There are no adjustments inside that will make a malfunctioning unit start working.**

LECTROSONICS service department is equipped and staffed to quickly repair your equipment. In-warranty repairs are made at no charge in accordance with the terms of the warranty. Out-of-warranty repairs are charged at a modest flat rate plus parts and shipping. Since it takes almost as much time and effort to determine what is wrong as it does to make the repair, there is a charge for an exact quotation. We will be happy to quote approximate charges by phone for out-of-warranty repairs. Our number is (505) 892-4501; Toll Free: (800) 821-1121.

## RETURNING UNITS FOR REPAIR

You will save yourself time and trouble if you will follow the steps below:

**A.** DO NOT return equipment to the factory for repair without first contacting us by letter or by phone. We need to know the nature of the problem, the model number and the serial number of the equipment. We also need a phone number where you can be reached 8 am to 4 pm (Mountain Standard Time).

**B.** After receiving your request, we will issue you a return authorization number (R.A.). This number will help speed your repair through our receiving and repair departments. The return authorization number must be clearly shown on the outside of the shipping container.

**C.** Pack the equipment carefully and ship to us, shipping costs prepaid. If necessary, we can provide you with the proper packing materials. UPS is usually the best way to ship the units. Heavy units should be "double-boxed" for safe transport.

**D.** We also strongly recommend that you insure the equipment, since we cannot be responsible for loss of or damage to equipment that you ship. Of course, we insure the equipment when we ship it back to you.

**Mailing address:**

Lectrosonics, Inc.  
PO Box 15900  
Rio Rancho, NM 87174  
USA

**Shipping address:**

Lectrosonics, Inc.  
581 Laser Rd.  
Rio Rancho, NM 87124  
USA

**Telephones:**

Regular: (505) 892-4501  
Toll Free (800) 821-1121  
FAX: (505) 892-6243

**World Wide Web:** <http://www.lectrosonics.com>

**Email:** [sales@lectrosonics.com](mailto:sales@lectrosonics.com)



## LIMITED ONE YEAR WARRANTY

The equipment is warranted for one year from date of purchase against defects in materials or workmanship provided it was purchased from an authorized dealer. This warranty does not cover equipment which has been abused or damaged by careless handling or shipping. This warranty does not apply to used or demonstrator equipment.

Should any defect develop, Lectrosonics, Inc. will, at our option, repair or replace any defective parts without charge for either parts or labor. If Lectrosonics, Inc. cannot correct the defect in your equipment, it will be replaced at no charge with a similar new item. Lectrosonics, Inc. will pay for the cost of returning your equipment to you.

This warranty applies only to items returned to Lectrosonics, Inc. or an authorized dealer, shipping costs prepaid, within one year from the date of purchase.

This Limited Warranty is governed by the laws of the State of New Mexico. It states the entire liability of Lectrosonics Inc. and the entire remedy of the purchaser for any breach of warranty as outlined above. NEITHER LECTROSONICS, INC. NOR ANYONE INVOLVED IN THE PRODUCTION OR DELIVERY OF THE EQUIPMENT SHALL BE LIABLE FOR ANY INDIRECT, SPECIAL, PUNITIVE, CONSEQUENTIAL, OR INCIDENTAL DAMAGES ARISING OUT OF THE USE OR INABILITY TO USE THIS EQUIPMENT EVEN IF LECTROSONICS, INC. HAS BEEN ADVISED OF THE POSSIBILITY OF SUCH DAMAGES. IN NO EVENT SHALL THE LIABILITY OF LECTROSONICS, INC. EXCEED THE PURCHASE PRICE OF ANY DEFECTIVE EQUIPMENT.

This warranty gives you specific legal rights. You may have additional legal rights which vary from state to state.



*Professional Audio Products Since 1971*

581 LASER ROAD  
RIO RANCHO, NM 87124 USA  
[www.lectrosonics.com](http://www.lectrosonics.com)