

FM transmitter & Coaster Pager User's manual

Thank you for purchasing the "LTK-P1200 transmitter & Guest paging system".

We are confident our cutting edge products and first rate service will satisfy your needs for years to come. Please read these instructions carefully before setting up your Guest Paging system!

EQUIPMENT SETUP

Keypad Sending Unit:

Unwrap all sending unit components. Lock the antenna into the hole in the upper right hand Corner of the sending unit. Plug the power supply with the large tip into a standard 110 outlet and plug it into the back of the sending unit. We recommend some type of surge suppressor on the power supply for protection. Power surges are not covered under system warranty!

Coaster Steup:

Locate the black charging base in a sturdy, out of the way location. Connect the charger bases together using the included jumper wires. Use the power-supply with the small tip and plug it into a standard 100 outlet and into either open plug on the charger base. Be sure to plug the jumpers & power supply jacks in all the way.

Stack the coasters on the black charging base. The coaster number will always face front and the red charge indicator light will be on the left.

We recommend that you do not stack coasters more than 15 high.

You should see a red light appear on each coaster. This light indicates proper charging is taking place.

Coaster Numbers:

On the front of each coaster is your coaster number

Surge Protection Recommended!!!

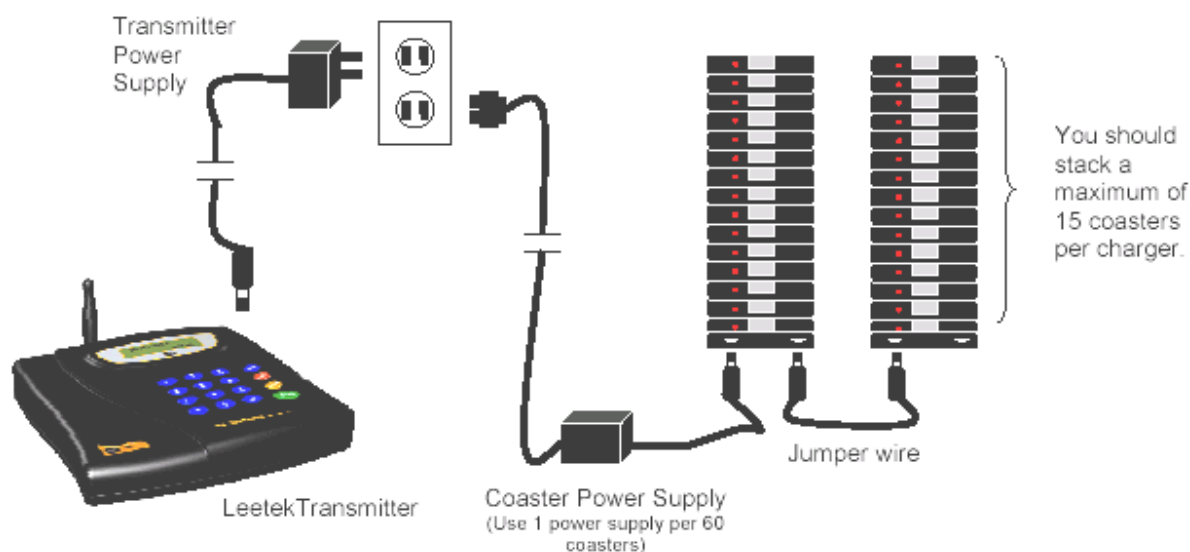

*Smpps adaptor (Transmitter Use: DC 12V 2.5A) , (Charger Base: DC12V 2.5A)

PLACEMENT & MOUNTING INSTRUCTIONS

DESKTOP:

You can use your transmitter with the 20 degree wedge attached or remove the wedge and lay the transmitter flat.

WALL MOUNT

To mount your transmitter on a wall:

- Remove the plastic bracket (included) under the transmitter unit by unlocking the 2 latches.
- Place the plastic bracket against the wall and with the aid of a pencil, mark the position of the mounting holes. (Refer to figure below). **Mount the transmitter in a convenient location where a power outlet is available.**

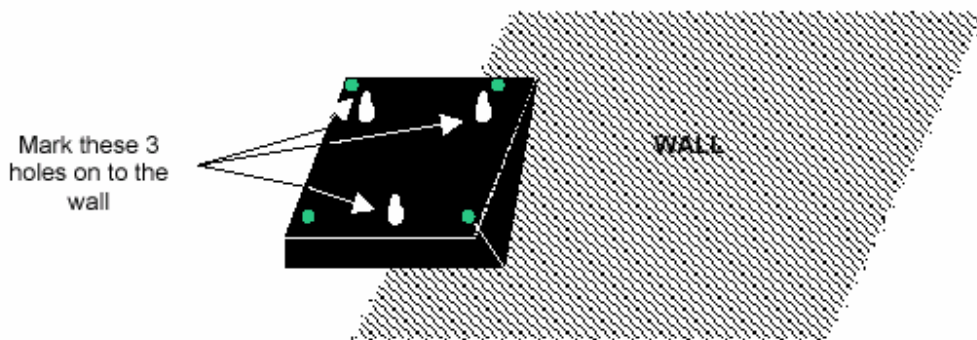

- Drill a hole on the marked position. Install the 3 mounting screws (and use anchors where necessary). Ensure that the screws are not fully tightened so that the unit can be easily removed from the wall.
- Place the transmitter onto the wall (without the plastic bracket). Plug the 2-amp wall transformer into any suitable AC outlet. Plug the power connector into the power jack on the top left hand side of the unit. Transmitter is now ready for use. Be certain to mount the transmitter away from phones, heat, moisture and exposed power circuits. These items can damage your system and shorten transmission range.

System Configuration

Your system was set at the factory and will function as soon as it is powered up.

Default setup is as follows:

Out of Range alert is off.

Coasters are set to Vibration & Flash when paged.

Set time(12:00 AM)

Range Test is off

This configuration should be satisfactory for most locations. Should the need arise to make any configuration changes follow the instructions below.

System Programming:

To enter programming mode, press the "SETUP" button and enter the password "3690" followed by "enter". If the password is accepted, the display will show "use * to scroll to menu options".

(Use the "* / Menu" key to scroll through the different menu options or press "CANCEL" to exit the system programming menu.)

1. Setting the "Out of Range" (for coasters only) (Factory Default: OFF)

With this feature, the coasters will play a Beep- sound for 10minute when taken out of range of the transmitter to inform the guest that they are out of range and will miss their page. The Beep-sound will stop, when they return back within range.

Be sure that all coasters are returned before turning out of range on or off.

TURNING THE OUT OF RANGE ON

- Remove all the coasters from the charging unit or unplug the power supply that is connected to the charging base
- At the "Out of Range" menu, press the "#/Select" key to turn the out of range **ON**.
- Press the "ENTER" key. After sending the signal, all the coasters will light up once to tell you that they received the new code.
- Press "CANCEL" key to exit the system programming menu.

To test the coasters with out of range on, unplug the power supply, that is connected to the transmitter. After 45 – 50 seconds, all the coasters will play a Beep-sound since they are not receiving a signal from the transmitter. Plug in the power supply back into the transmitter. After a few seconds, all coasters will stop playing the Beep-sound. Return all the coasters to the charging base or plug the power supply. The coasters are ready to receive the page with the out of range feature turned on.

TURNING THE OUT OF RANGE OFF

- Remove all the coasters from the charging unit or unplug the power supply that is connected to the charging base
- At the "Out of Range" menu, press "#/Select" key to turn the out of range **OFF**.
- Press "ENTER" key. After sending the signal, all the coasters will light up once to tell you that they received the new code.
- Press "CANCEL" key to exit the system programming menu.

To test the coasters with out of range off, unplug the power supply, that is connected to the transmitter. After 45 - 50 seconds, all the coasters should not play the Beep-sound since the out of range were turned off. If all or some of the coasters are playing the Beep-sound, repeat the procedure above. If none of the coasters are playing the Beep-sound, return all the coasters to the charging base or plug the power supply. Plug the power supply of the transmitter. The coasters are ready to receive the page with the out of range feature turned off.

2. Set the Current Time

- At the “**Set Current Time**” menu, set the hour then press “**ENTER**” key.
- Set the minutes and press “**ENTER**” key.
- Use the “**# /Select**” key to select AM or PM.
- After the correct time is set, press the “**ENTER**” or “*** / Menu**” key to return to the main menu or press the “**CANCEL**” key 2 times to exit the system programming menu.

3. Set Pager Alert (Factory Default: Vibration & Flash)

With this feature you have the option of changing the way your coasters alert the guest.

Be sure that all coasters are returned before performing this procedure.

To change the alert mode of your coasters follow these instructions:

- Remove all the coasters from the charging unit or unplug the power supply that is connected to the charging bases.
- At the “**Set Pager Alert**” menu, press the “**#/Select**” key to scroll through the different alert options.
- After making a selection, press the “**enter**” key . After sending the code, the coasters will now respond with your new selection.
- Press “**CANCEL**” key to exit the system programming menu
- Return all the coasters to the charging base or plug the power supply. The coasters are ready to receive the page with the new alert.

(3 type Option: Vibration & Flash / Vibration & Beep / Vibration only)

4. Range Test (Factory Default : OFF)

With this feature you can determine what distance your transmitter will cover.

- Remove a couple of coasters from the charging stack.
- At the range test menu, press “**#/Select**” key to turn range test “ON”.
- Press “**ENTER**” to start the range test. As soon as range test is activated you’ll notice the coasters flash once every 3 seconds (if you use pagers they will vibrate). Walk around your property. When you reach the point where the coasters do not flash consistently, this is your maximum range.
- Press the “**CANCEL**” key to stop the range test. Press the “**CANCEL**” key again to exit the system programming menu.

NOTE : The transmitter has an auto shut off feature that will stop the range test after 15 minutes.

5. program to pager

Press Pager # to change the Number of Pager.

- Connect the programmer to Hole-Pin of Coaster Pager.
At the same time , Enter Pager # to modification, and then press the “**ENTER**” key,
- Verify OK sign: Beep sound & LED blinking.
- Press only Pager # to change the Number.
- Base ID & Group ID reserve a seat beforehand.(It is marked by numeral)



(Coaster Pager user's manual)

Handing out the Coasters:

Give the guest a coaster. Note their name and Coaster number on the sign out sheet(Included). Tell the guest the coaster will signal when their table(or Food) is ready. The default page for this system is for the coaster to flash and vibrate for 3 minutes. After the coaster is finished vibrating it automatically goes back into standby mode waiting for the next page. You can hand the coasters out right from the charging stack (They will “demo” Page each time they are removed from the stack) or you can simply store them in a basket and hand them out. A fully Charged coaster will function without being recharged for 8 – 12 hours.

(The Charging Light on the chargerbase : RED Color.

The Indicator of fully charged Coaster on the chargerbase : GREEN Color)

Paging the Guest:

When the guest's table(or food) is ready simply press the coaster number on the transmitter Keypad followed by the “send” key. For example. Press “11, *send*” and coaster # 11 will signal.

Out of range Feature

With this feature, the coaster will play a melody to inform your customer that they are out of range and will miss their page. The melody will only stop if they are within range. Default from the factory is Out of Range Off (Transmitter setting)

- **Out of Range On** *(After sending the signal, all the coasters will light up once to tell you that they received the ON code. - Clockwise lighting)*
- **Out of Range Off** *(After sending the signal, all the coasters will light up once to tell you that they received the OFF code.-Anti-clockwise lighting)*

To turn the Out of range feature an follow these procedures:

Remove all the coasters from the charging base or simply unplug the power supply that is connected to the charging unit. Please select the “Out of Range ON” in SETUP MODE of the Transmitter. After making a selection, press the “enter” key. All the coasters will light up to tell you that they have received the new code. To test the coasters, unplug the power supply that is connected to the LEETEK transmitter. After 45 seconds, all the coasters will play a melody since they are not receiving a signal from the transmitter. Return all the coasters to the charging base or plug in the power supply. The coasters are ready to receive a page with the out of range feature turned on.

Follow the same procedure to turn the out of range feature off, but use the “Out of Range OFF” in SETUP MODE of the transmitter.

Alert stop Feature

To stop the page, from the transmitter press # “11”- enter - 99 -send

This will put coaster # 11 to stop the page individually (Do not put it to sleep all we need is to stop the page). To repage, press “ 11, send ” and coaster #11 will signal.

GuestCall Guest Paging System Operation

1. When a guest arrives, remove a coaster from the stack. It will alert for 10 seconds while you show them and explain what they will be looking for when they are paged. Write the coaster number next to the person's name on the wait list.
2. When their table becomes available, simply enter their coaster number into the transmitter and press "send".

Example of Host/Guest Greeting

Host: Good evening Sir. Welcome to _____. How many are in your party tonight?

Guest: Hello, there will be 4 of us.

Host: Your name please.

Guest: Smith

Host: Thank you Mr. Smith, do you have a smoking preference?

Guest: Yes, non-smoking.

Host: OK Sir, that's the Smith party of 4 for a non-smoking table, correct?

Guest: Yes

Host: We currently have a 30 minute wait for a table. Here, please take one of our Coasters. (Remove a coaster from the stack... it signals... hand it to the guest.)

Host: Keep this coaster with you. It will flash / vibrate just like this when your table is ready. When it goes off, come back to the host stand and we will seat you. You may go to the bar if you'd like and use the coaster for your drink or you can sit out front on one of our benches. The coaster has a built in alarm that will "beep sound" if you have gone out of range and cannot be paged. If it starts to beep sound, simply walk back towards the restaurant and it will stop singing when you get back into range.

Guest: WOW! This is great. What a neat idea! You guys really know how to take care of your guests.

Host: Thank you Mr. Smith, we'll see you in about 30 minutes.

GuestCall Troubleshooting

Charge light will not come on

- a. Make sure there is power to the outlet
- b. Try changing the position of the coasters on the stack. Make sure they are seated properly with the numbers facing front.
- c. Using a damp rag, clean metal contacts on coaster that will not light
- d. Check all connections on charger bases. If only one stack of coasters will not light on the charger, There is probably a bad connection. Move wires and be sure they are all plugged into back of black coaster charger.

If you try all this and the coaster charging light will not come on you most likely have a blown power supply.

Transmitter will not display anything

- a. Make sure there is power to the outlet
- b. Check all connections.

If you try all this and the transmitter still wont power up your power supply may be bad. If display is still blank, call NTN.

No range on coaster pagers

- a. Be sure transmitter is not near any large metal objects, fire walls, etc.
- b. Be sure antenna is connected properly and not broken.

Coasters are not paging or paging in a manner you did not program

Review Coaster modes and enter the code for the mode you would like. It probably has changed.

Coasters are not answering the page or acting strange

Make sure the Coaster has a full charge.

LEETEK warrants this product against any defects that are due to faulty material or workmanship for a one-year period after the original date of consumer purchase. This warranty does not include damage to the product resulting from accident, misuse or improper electrical connection. **Power supplies are warranted for 60 days. We recommend the use of a surge protector with all equipment.** If this product should become defective within the warranty period, we will repair or replace with equivalent product, free of charge. We will return your product, transportation charges prepaid standard shipping mode, provided the product is shipped prepaid to:

LEETEK, #24-2 Samjeong-dong, Ojung-gu, Puchon-city, Kyunggi-do, Korea

No return will be received without prior authorization and the proper RMA # posted to the outside of the shipping container.

This warranty gives you specific legal rights and you may also have rights which vary from state to state.

Ship malfunctioning components to the following address:

**#24-2 Samjeong-dong, Ojeong-gu,
Puchon-city, Kyunggi-do, Korea
82-32-678-8605**

LEETEK (LEE TECHNOLOGY KOREA.CO., LTD)

www.leeTek.org

leetek2001@yahoo.co.kr

Tel:82-32-678-8605

Fax:82-32-682-8605