



Leica S
Instructions

FOREWORD

Dear Customer,

Leica would like to thank you for purchasing the Leica S and congratulate you on your choice. With this unique medium-format digital SLR camera, you have made an excellent choice.

We wish you a great deal of pleasure and success using your new Leica S.

In order to make best use of all the opportunities offered by this high performance camera, we recommend that you first read this instruction manual.

Your Leica Camera AG

Note:

Leica is constantly working on developing and optimizing the Leica S. As many functions on digital cameras are controlled purely electronically, improvements and extensions to the range of functions may need to be installed on the camera at a later date. To do this, Leica releases what are known as firmware updates at irregular intervals. Cameras are always supplied from the factory with the latest firmware, but you can easily download the updates to your camera yourself from our website.

If you register as an owner on the Leica Camera website, you will receive a newsletter informing you when a new firmware update is available.

Further information on registration and on firmware updates for your Leica S and on any changes or additions to the details in this manual can be found on our website under "Customer Service" at:

<https://owners.leica-camera.com>

To check whether your camera and lenses are running the latest firmware version, select menu option "Firmware" (see p. 66, 16-19).

FCC Note:

This equipment has been tested and found to comply with the limits for a Class B digital device, pursuant to Part 15 of the FCC Rules. These limits are designed to provide reasonable protection against harmful interference in a residential installation. This equipment generates, uses, and can radiate radio frequency energy and, if not installed and used in accordance with the instructions, may cause harmful interference to radio communications. However, there is no guarantee that interference will not occur in a particular installation. If this equipment does cause harmful interference to radio or television reception, which can be determined by turning the equipment off and on, the user is encouraged to try to correct the interference by one or more of the following measures:

- Reorient or relocate the receiving antenna.
- Increase the separation between the equipment and receiver.
- Connect the equipment into an outlet on a circuit different from that to which the receiver is connected.
- Consult the dealer or an experienced radio/TV technician for help.

FCC Caution:

To assure continued compliance, follow the attached installation instructions and use only shielded interface cables with ferrite core when connecting to computer or peripheral devices. Any changes or modifications not expressly approved by the party responsible for compliance could void the user's authority to operate this equipment.

Trade Name: LEICA
 Model No.: LEICA S (Typ 007)
 Responsible party/
 Support contact: Leica Camera Inc.
 1 Pearl Count, Unit A
 Allendale, New Jersey 07401
 Tel.: +1 201 995 0051
 Fax: +1 201 995 1684
 technicalinfo@leicacamerausa.com

This device complies with Part 15 of the FCC Rules. Operation is subject to the following two conditions: (1) This device may not cause harmful interference, and (2) this device must accept any interference received, including interference that may cause undesired operation.

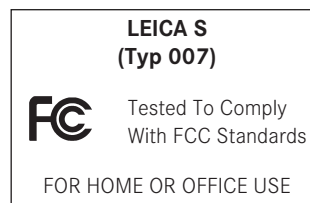
**Contains FCC ID: N5AS007**

This transmitter must not be co-located or operated in conjunction with any other antenna or transmitter. This equipment complies with FCC radiation exposure limits set forth for an uncontrolled environment and meets the FCC radio frequency (RF) Exposure Guidelines. This equipment has very low levels of RF energy that are deemed to comply without testing of specific absorption ratio (SAR).

For Canada only:

CAN ICES-3 (B)/NMB-3(B)

This device complies with RSS-210 of the IC Rules. Operation is subject to the following two conditions:

- (1) This device may not cause harmful interference,
- (2) This device must accept any interference received, including interference that may cause undesired operation of the device.

This equipment complies with IC radiation exposure limits set forth for an uncontrolled environment and meets RSS-102 of the IC radio frequency (RF) Exposure rules. This equipment has very low levels of RF energy that are deemed to comply without testing of specific absorption ratio (SAR).

TABLE OF CONTENTS

Foreword	2	Basic picture settings	
Warning messages	6	Photo file format	22
CE mark	6	JPEG settings	
Legal information	6	Resolution	22
Disposal of electrical and electronic equipment	6	Working color range	22
Package contents	6	Contrast, focus, color saturation	22
		Resolution	22
Designation of parts	7	White balance	22
		Automatic and fixed settings	23
Preparations		Direct color temperature setting	23
Attaching the carrying strap	8	Manual setting by metering	23
Charging the battery	8	ISO sensitivity	24
Inserting and removing the battery into/from the camera	11	Storage of picture data / memory card management	25
Charge level displays	11		
Changing memory cards	11	Recording mode	
Changing the focusing screen	13	For photos	
Leica S lenses	14	Shutter release button	26
Fitting and removing	14	Interval shooting	26
Adjusting the eyepiece	15	Live View mode	27
Turning the camera ON and OFF	15	Exposure simulation	27
		Displays in Live View mode	27
Menu control	16	Histogram	27
Navigating in the menu / setting the functions	17	Clipping displays	27
Quick access to menu functions	18	Marking of clearly focused subjects (focus peaking)	28
		Grid	28
Presets		Horizon	28
Basic camera settings		Masking	28
Menu language	20	Enlarging the Live View monitor image	28
Date and time	20	Distance setting	29
Auto power OFF	20	Manual setting of the focus - MF	29
Monitor and top panel display	21	Automatic setting	29
Signal tones	21	AFs - focus priority	29
		AFC - shutter release priority	29
		Moving the autofocus metering field in Live View mode	29
		Exposure metering	30
		Exposure metering methods	30
		Spot metering	30
		Center weighted metering	30
		Multi-field metering	30
		Metering memory lock	32
		Saving with the Joystick	32
		Exposure compensation	32
		Bracketing	33
		Values above and below the metering range	34

Exposure control			
Automatic program	30		
Program shift	31		
Aperture priority	31		
Shutter speed priority	31		
Manual setting of aperture and exposure time	33		
Taking photographs with the self-timer	34		
Mirror lock-up	35		
Depth of field preview button	35		
Additional functions			
User/application-specific profiles	36		
Resetting all custom settings	36		
Folder management	37		
Formatting of memory card(s)	37		
Marking picture data for copyright protection	38		
Recording the location with GPS	38		
Flash mode			
General information on flash exposure measurement and control	39		
Compatible flash units	39		
Flash sync speed	39		
Selecting the sync speed / sync speed range	40		
Selecting the firing moment	40		
Attaching the flash unit	40		
Settings for camera-controlled			
automatic flash mode	41		
TTL flash mode	41		
Linear flash mode (HSS)	41		
Stroboscope flash mode with system-compatible flash units	41		
Flash exposure displays in the viewfinder with			
system-compatible flash units	42		
Flash photography with the flash unit-integrated automatic computer	42		
Manual flash photography with constant flash power	42		
Flash photography via the X contact	42		
Flash photography via the flash / lower LEMO® jack	42		
Video recordings	43		
Review mode			
Automatic review of last picture	46		
Review for unlimited time	46		
Video playback	46		
Setting the volume	47		
Displays in Review mode	47		
Review with histogram and clipping indicators	47		
Viewing other pictures / scrolling	48		
Enlarging the detail	48		
Stepwise enlarging	48		
Maximum enlargement in one step	48		
Moving the detail	49		
Simultaneous viewing of several reduced pictures	49		
Selection of one of the reduced pictures	49		
Protecting pictures / clearing delete protection	50		
Deleting pictures	50		
Additional functions			
Transferring data to a computer	51		
Connecting and transferring the data using card scanners	51		
Data structure on the memory card	51		
LEICA Image Shuttle	51		
Installing firmware updates	51		
Wireless data transmission and remote control of the camera	52		
Miscellaneous			
System accessories	53		
Spare parts	53		
Precautions and care instructions	54		
General precautions	54		
Care instructions	54		
Cleaning the sensor	55		
Storage	55		
Index	56		
Technical data	58		
The displays			
In the viewfinder	60		
In the top panel display	61		
In the monitor	62		
Menu items	66		
Leica service addresses	67		

WARNING MESSAGES

- Modern electronic components react sensitively to electrostatic discharge. As you can easily pick up charges of tens of thousands of volts by walking on synthetic carpets, for example, a discharge can occur when you touch your Leica S, particularly if it is lying on a conductive surface. If only the camera body is touched, this discharge is harmless to the electronics. However, despite built-in safety circuits, outer contacts such as those in the bottom of the camera should not be touched if at all possible for safety reasons.
- For any cleaning of the contacts, please do not use an optical microfiber cloth (synthetic); use a cotton or linen cloth instead! Before touching the contacts, you can make sure you discharge any electrostatic charge by deliberately touching a heating or water pipe (conductive, earthed material). You can also avoid soiling and oxidization of the contacts by storing your Leica S in a dry place with the lens or bayonet cover fitted!
- Use only the recommended accessories to prevent faults, short circuits or electric shock.
- The Leica S is protected against spray water and dust. However, it should not be exposed to rain for prolonged periods.
- Do not attempt to remove parts of the body (covers); qualified repairs can be carried out only at authorized service centers.

LEGAL INFORMATION

- Please ensure that you strictly observe copyright laws. The recording and publication of pre-recorded media such as tapes, CDs, or other published or broadcast material may contravene copyright laws.
- This also applies to all of the software supplied.
- The SD, HDMI, CF and USB logos are trademarks.
- Other names, company and product names referred to in these instructions are trademarks or registered trademarks of the relevant companies.

The CE identification of our products documents compliance with the fundamental requirements of the respective valid EU directives.



The production date of your camera can be found on the stickers in the warranty card and/or on the packaging.

The date convention is: **Year/Month/Day**

In the menu, under **Camera Information**, you will find the specific approvals for this camera under the point **Regulatory Information**.



DISPOSAL OF ELECTRICAL AND ELECTRONIC EQUIPMENT

(Applies within the EU, and for other European countries with segregated waste collection systems.)

This device contains electrical and/or electronic components and should therefore not be disposed of in general household waste. Instead it should be disposed of at a recycling collection point provided by the local authority.

This costs you nothing. If the device itself contains replaceable (rechargeable) batteries, these must be removed first and, if necessary, also be disposed of in line with the relevant regulations.

Further information on this issue is available from your local administration, your local waste collection company, or in the store where you purchased this device.

PACKAGE CONTENTS

Before using your Leica S for the first time, please check that the accessories supplied are complete.

- Li-Ion Battery S BP-PRO 1
- Quick Charger S with interchangeable mains plugs
- Carrying strap
- Bayonet cover
- Eyepiece cover

MEANING OF THE DIFFERENT NOTE CATEGORIES IN THIS MANUAL

Note:

Additional information

Important:

Failure to observe the instructions may cause damage to the camera, accessories or the photos.

Caution:

Failure to observe the instructions may cause personal injury.

DESIGNATION OF PARTS

Front view

- 1** Shutter release button
- 2** Self-timer LED / sensor for white balance
- 3** Microphones
- 4** Depth of field preview/function button
- 5** Bayonet with
 - a. contact strip
 - b. Index point for fitting the lens
 - c. Lens release button

Top view

- 6** Carrying strap attachment
- 7** Window for range scale
- 8** Focusing dial
- 9** Lens hood bayonet
- 10** Red index button for changing lenses
- 11** Shutter speed setting dial
- 12** Video record button
- 13** Live View button
- 14** Top panel display
- 15** Diopter setting dial with
 - a. scale
 - b. Eyecup
- 16** Accessory shoe with
 - a. center (firing) contact
 - b. Control contacts
 - c. Bore for locking pin
- 17** GPS antenna

Rear view

- 18** Main switch with stop positions
- 19** Viewfinder
- 20** Joystick
- 21** Rear setting dial
- 22** Speaker
- 23** Cover (closed)
- 24** LED for recording / data storage on card
- 25** Review / menu control / function button
- 26** Menu control / function button
- 27** Monitor
- 28** Menu control / function button
- 29** Menu control / function button
- 30** Cover (closed)
- 31** Cover (closed)
- 32** Brightness sensor

View from right (view without cover)

- 33** CF card slot with
 - a. ejection slide
- 34** SD card slot

View from left (view without covers)

- 35** LEMO® audio socket
- 36** HDMI socket
- 37** LEMO® USB 3.0 socket
- 38** LEMO® remote control / flash synchronization / audio in/out socket

Bottom view

- 39** Index hole for guide pin of multifunction hand grip
- 40** Cover
- 41** Tripod plate with
 - a. ¼" thread
 - b. ⅜" thread
 - c. Index holes for twist lock
- 42** Battery release lever
- 43** Battery
- 44** Battery compartment (battery removed) with
 - a. contacts
 - b. Guide strip
- 45** Contact strip for multifunction hand grip (cover removed)

Battery

- 46** Contacts
- 47** Guide slot
- 48** Socket for charger plug

Charger

- 49** Battery connecting cable fixed to camera with
 - a. 3-pin plug
- 50** Orange LED for charge indicator
- 51** Green LED for display of the charging process
- 52** 2-pin socket for car charging cable
- 53** Interchangeable mains plug (Europe/GB/AUS) with
 - a. release button
- 54** USA mains plug (interchangeable plug removed)
- 55** Car charging cable with
 - a. 2-pin plug for charger
 - b. Plug for cigarette lighter

PREPARATIONS

ATTACHING THE CARRYING STRAP

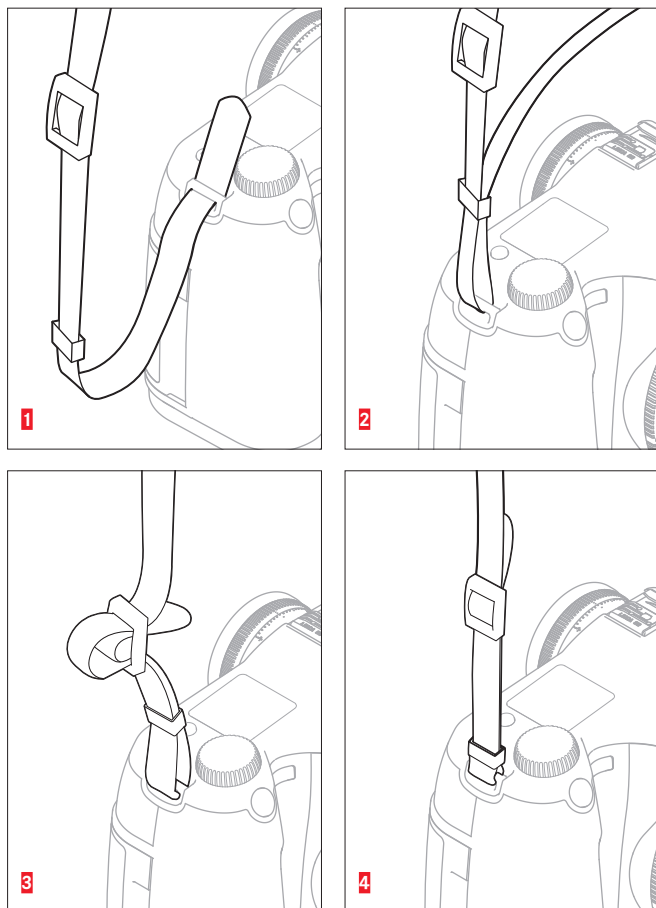

CHARGING THE BATTERY

The Leica S is powered by a lithium ion battery (A).

Important:

Batteries from the earlier Leica S models (Order No.14 429) cannot be used either in the Leica S (Typ 007) or in the multifunction hand grip. Please use only the Leica battery S **BP-PRO1** (Order No. 16 039).

Caution:

- Only the battery type specified and described in this manual, or battery types specified and described by Leica Camera AG, may be used in this camera.
- These batteries may only be used in the units for which they are designed and may only be charged exactly as described below.
- Using this battery contrary to the instructions and using non-specified battery types can result in an explosion under certain circumstances!
- The batteries must not be exposed to sunlight or heat for prolonged periods, or to humidity or moisture. Likewise, the batteries must not be placed in a microwave oven or a high pressure container as this results in a risk of fire or explosion!
- Damp or wet batteries must not be charged or used in the camera under any circumstances!
- Always ensure that the battery contacts are clean and freely accessible. Whilst lithium ion batteries are proofed against short-circuit, they should still be protected against contact with metal objects such as paper clips or jewelry. A short-circuited battery can get very hot and cause severe burns.
- If a battery is dropped, check the casing and the contacts immediately for any damage. Using a damaged battery can damage the camera.
- In case of noise, discoloration, deformation, overheating or leaking fluid, the battery must be removed from the camera or charger immediately and replaced. Continued use of the battery results in a risk of overheating, which can cause fire and/or explosion!
- In case of leaking fluid or a smell of burning, keep the battery away from sources of heat. Leaked fluid can catch fire!

- Only the charger specified and described in these instructions, or other chargers specified and described by Leica Camera AG, may be used. The use of other chargers not approved by Leica Camera AG can cause damage to the batteries and, in extreme cases, can cause serious or life-threatening injuries.
- The charger supplied should be used exclusively for charging this battery type. Do not attempt to use it for other purposes.
- Ensure that the power socket used is freely accessible.
- The car charging cable supplied must never be connected while the charger is connected to the mains.
- Battery and charger must not be opened. Repairs may only be carried out by authorized service centers.
- Keep batteries out of the reach of children. Batteries can cause suffocation if swallowed.

First aid:

- If battery fluid comes into contact with the eyes, there is a risk of blinding! Rinse the eyes immediately with clear water. Do not rub the eyes!
- Obtain medical assistance immediately.
- If leaked fluid gets onto the skin or clothing, there is a risk of injury. Wash the areas concerned with clear water. Obtain medical assistance.

Notes:

- The battery must have a temperature of +10° to +30°C to be charged (otherwise the charger will not turn on, or will turn off again).
 - Lithium ion batteries can be charged at any time, regardless of their current charge level. If a battery is only partly discharged when charging starts, it is charged to full capacity faster.
 - A new battery only reaches its full capacity after it has been fully charged and – by use in the camera – discharged again 2 or 3 times. This discharge procedure should be repeated roughly every 25 cycles.
 - Both battery and charger become warm during charging. This is normal and not a malfunction.
 - If the two LEDs flash rapidly (> 2 Hz) after the start of charging, this indicates a charging error (e.g. maximum charging time exceeded, voltages or temperatures outside the permitted ranges, or short circuit). In this case, disconnect the charger from the mains and remove the battery. Ensure that the above temperature conditions are met and then restart the charging process.
 - If the problem persists, please contact your dealer, the Leica office in your country or Leica Camera AG.
 - Lithium ion batteries should only be stored partly charged, i.e. not when fully discharged or fully charged. For very long storage periods, you should charge the battery for approx. 15 minutes roughly twice a year to avoid a deep discharge.
 - Rechargeable lithium ion batteries generate power through internal chemical reactions. These reactions are also influenced by the ambient temperature and humidity. To ensure a maximum service life of the battery, it should not be exposed to constant extremes of temperature (e.g. in a parked car in the summer or winter).
 - Even when used under optimum conditions, every battery has a limited service life! After several hundred charging cycles, this becomes noticeable as the operating times become significantly shorter.
 - Dispose of damaged batteries in accordance with the relevant regulations (see p. 6, 54) at an approved collection point for proper recycling.
- The replaceable battery provides power to a back-up battery which is permanently fitted in the camera. This back-up battery retains the set time and date for up to 3 months. If this back-up battery becomes discharged it must be recharged by inserting a charged main battery. Once the replaceable battery has been inserted, the full capacity of the back-up battery is recovered after about 60 hours. This process does not require the camera to be turned on. In this case, however, the time and date have to be set again.
 - Remove the battery if you will not be using the camera for a long period of time. When doing so, turn the camera off using the main switch first. Otherwise after several weeks the battery could undergo deep discharge, i.e. the voltage is sharply reduced, as the camera still consumes a small amount of current (e.g. for saving your settings) even when it is turned off.

PREPARATION OF THE CHARGER

for use outside the USA

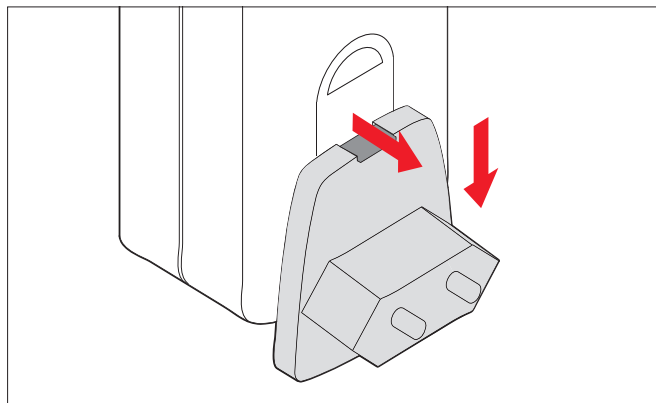

1. Insert the appropriate plug for the local mains power supply into the charger.
To do this, push up
 - a. the release button and at the same time push
 - b. the plug down out of its engaged position.
2. It can then be removed completely downwards.
3. Push the appropriate plug variant into the charger from below until it engages.

for use in the USA

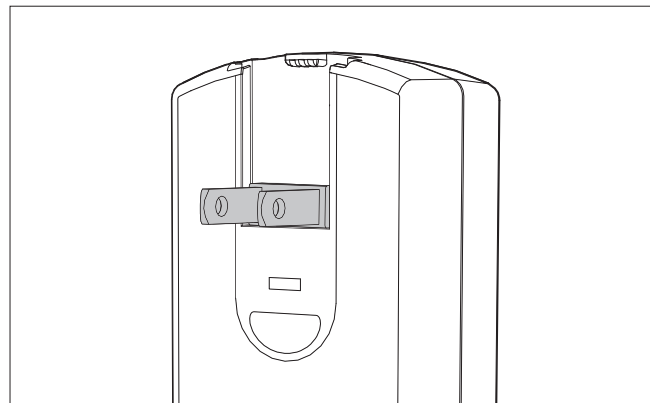

1. Remove the mains plug fitted at the factory from the charger. To do this, push up
 - a. the release button and at the same time push
 - b. the plug up out of its engaged position.
2. The two pins of the USA plug that are normally horizontal when not in use can then be folded out.

Notes:

The charger switches automatically to the prevailing mains voltage. In combination with the car charging cable supplied with the charger, it can be used in all vehicles with 12 V and 24 V power systems. In this case again, it switches over automatically.

CONNECTION OF THE CHARGER

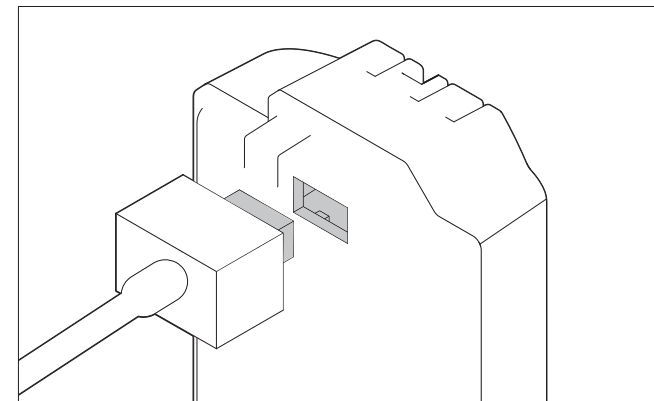

1. Connect up the charger, i.e. insert its cable plug into the socket of the battery and insert the mains plug into a plug socket.
 - The green LED marked **CHARGE** then starts to flash as confirmation that charging is in progress.
 - As soon as the battery has charged to at least $\frac{1}{3}$ of its capacity, the orange LED marked 80% also lights up.
 - When the battery has been completely charged after approx. 3½ hours, 100% capacity has been reached, the flashing green **CHARGE** LED changes to a steady light.

Notes:

- The 80% LED lights up after around 2 hours due to the charging characteristics. If the full capacity of the battery is not absolutely necessary, the camera can be ready for use again in a relatively short time.
 - The steady light of the green CHARGE LED indicates that the charger has automatically switched to trickle charging.
2. The charger should then be disconnected from the mains power supply. There is, however, no risk of overcharging.

CHANGING THE BATTERY

Preparations

Turn off the camera, i.e. set the main switch to **OFF**.

Insertion

Push the battery with the contacts facing forward and with its guide groove facing the middle of the camera fully into the battery compartment. It engages automatically in this position.

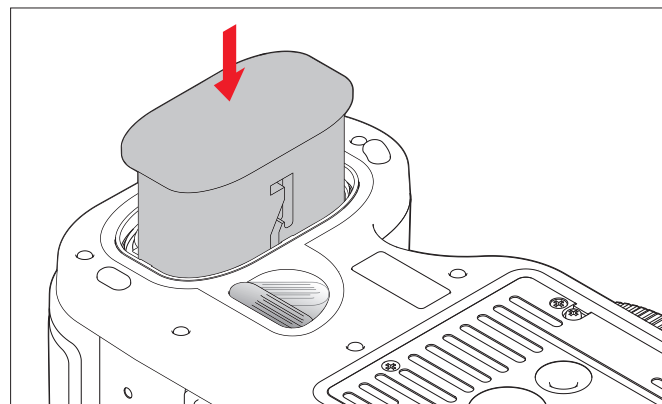

Removal

- Turn the release lever in clockwise direction until it stops
 - A spring in the battery compartment then pushes the battery approx. 1 cm out.
 - The locking mechanism has a detent so that the battery cannot accidentally fall out even if the camera is held upright.
- Push the battery approx. 1 mm back to disengage the detent, and
- then pull it out of the compartment or, if the camera is held upright, allow the battery to slide out into your hand.

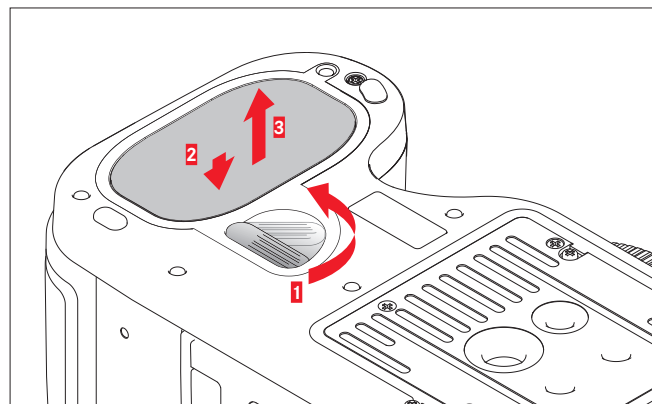

- Open the cover on the right-hand side of the camera, i.e. push back slightly to unlock, then fold open to the right.

Note:

Do not touch the memory card contacts.

CF cards (CompactFlash)

Insertion

Push the card with the contacts facing towards the camera and with the front facing towards the front of the camera fully into the slot.

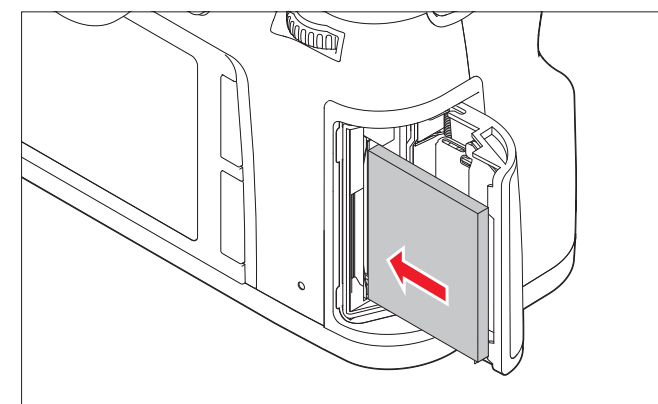

Note:

Ensure that the ejection slide is completely pushed in (see "Removal" on the following page).

Important:

Do not use force! The contacts in the card slot could otherwise be damaged!

CHARGE LEVEL DISPLAYS

Monitor	Top panel display	Charge status
		approx. ≥ 85%
		approx. ≥ 65%
		approx. ≥ 40%
		approx. ≥ 20%
		approx. ≥ 5%
		approx. ≤ 5%, replacement or recharging of the battery necessary

CHANGING MEMORY CARDS

The Leica S offers you the possibility of using 2 card types in parallel for storing of recorded data. It has two card slots, one for SD/SDHC/SDXC (Secure Digital) cards and one for CF (Compact Flash up to UDMA 7) cards.

Preparations

- Turn off the camera, i.e. set the main switch to **OFF**.

Note:

Do not turn off the camera as long as the LED for data storage is still lit.

Removal

1. Push the ejection slide inwards.
 - The slide is then pushed out slightly.
2. Press the slide inwards again.
 - The card is then pushed slightly out of the slot.
3. Pull out the card.

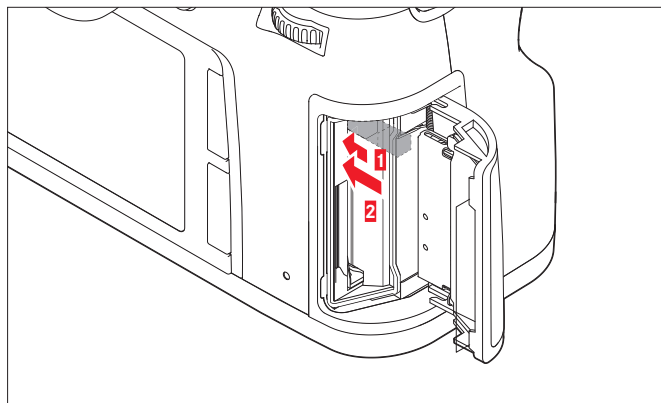
**SD / SDHC / SDXC cards****Insertion**

Push the card completely into the slot with the contacts facing to the rear and with the beveled corner facing upwards against the spring pressure until it engages audibly.

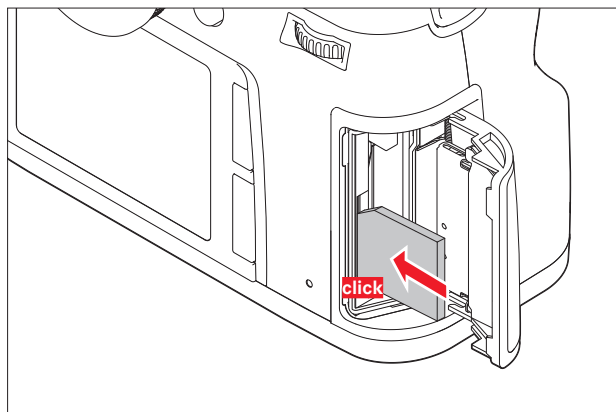
**Important:**

Ensure that no SD/SDHC/SDXC card is pushed into the CF card slot as it might not be possible to remove it again!

Removal

1. Press the card further into the slot.
 - The card is released and pushed slightly out of the slot.
2. Pull out the card.

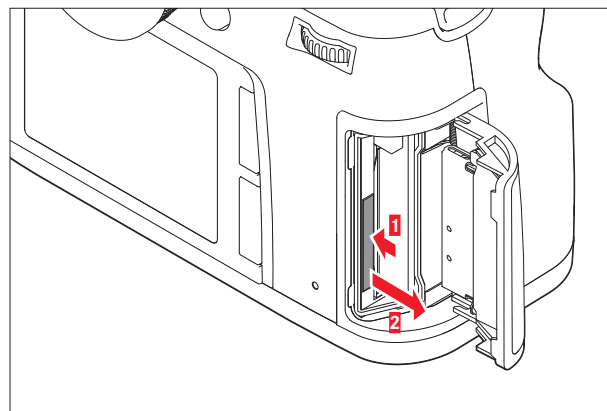
**Close cover**

Close the cover and push forward until it engages.

Displays

Memory card faults are indicated by different messages in the viewfinder, monitor and top panel display.

Notes:

- If the memory cards cannot be inserted, check that they are aligned correctly.
- The range of memory cards available is too large for Leica Camera AG to be able to completely test all available types for compatibility and quality. Although using other card types is not likely to damage the camera or the card, some "no name" cards do not comply with the memory card standards, and Leica Camera AG is unable to provide any guarantee that they will function correctly.
- Do not remove either a memory card or the battery as long as the red LED at the bottom right next to the monitor is flashing, indicating picture recording and/or data saving to the card(s). Otherwise the unsaved (or not completely saved) picture data may be lost.
- The Leica S offers different variants for the storage of picture data. Further information on this topic can be found under "Storage of picture data / memory card management".
- As electromagnetic fields, electrostatic charges, and defects in the camera or the card(s) can lead to damage or loss of the data on the memory card(s), we recommend that you also transfer the data to a computer and save it there.
- For the same reason we also recommend that the cards are always stored in an antistatic case.
- The proper function of the camera cannot be guaranteed if WiFi cards are used.
- SD, SDHC, and SDXC memory cards have a write protection switch, which can be used to prevent unintentional storage and deletion of pictures. This switch takes the form of a slider on the non-beveled side of the card; in the lower position, marked LOCK, the data is protected.
- Memory cards with a capacity of less than 1 GB cannot be used.

CHANGING THE FOCUSING SCREEN

The Leica S allows the focusing screen to be changed (see also "System accessories / Interchangeable focusing screens". As standard the camera is supplied with a completely matt screen.

The other focusing screens are delivered individually in a case with tweezers and a dust brush.

To change the screen

1. Remove the lens, and

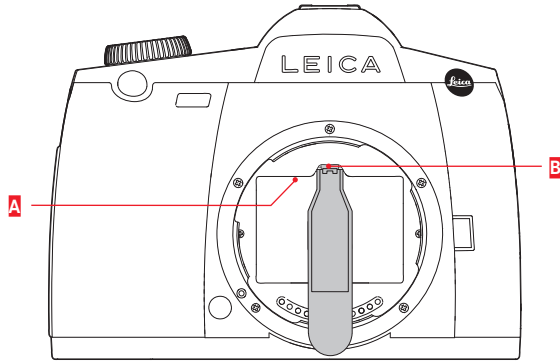

2. Release the screen frame **A** from its engaged position by pressing the tab **B** with the tip of the tweezers.

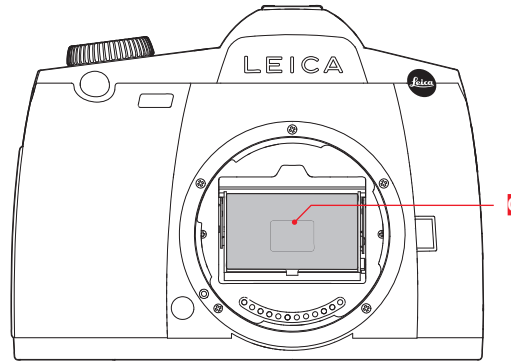

3. Then grip the focusing screen **C** at the small tab using the tweezers, tilt it forwards slightly and remove.
4. Then place the screen temporarily into the side compartment of the case.

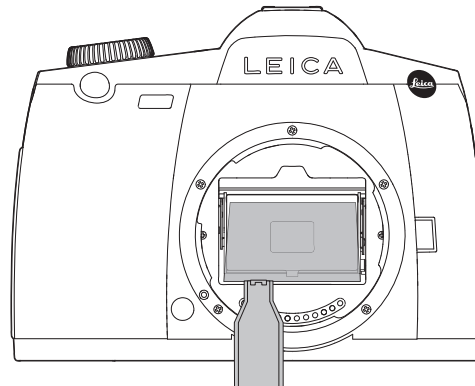

5. Grip the screen to be installed with the tweezers at its tab, place into the frame and
6. press the frame upwards into its engaged position with the tip of the tweezers.

Important:

Proceed exactly as described above when changing the screen. Take particular care to protect the delicate surfaces of the focusing screens from scratches.

LEICA S LENSES

Leica S lenses have a number of characteristic features:

- The focusing ring functions differently, depending on the set focus operating mode:
- In manual mode (MF), the focus is set in the normal way by turning the ring - in this case it is already mechanically linked to the lens construction.
- In autofocus mode (AFs/AFc) it is initially disconnected - so that holding the lens at the ring does not hinder the motorized adjustment. However, you can "override" the automatic setting at any time, i.e. set the focus manually even during AF mode. In this case the ring is immediately linked to the lens construction as soon as it is turned.
- The internal range scale can be read off through a window.
- They have no aperture setting ring. The aperture is set using the thumbwheel on the camera body.

Note:

- Some Leica S lenses are also available with integral central shutter.
- Leica Camera AG manufactures its products to the highest standards of quality. In order to ensure their perfect function, extensive calibration and testing steps are necessary during the production process. For this purpose the camera is connected to different testing devices several times. These important production steps can create minor shiny spots on the stainless steel bayonet ring. This is not a quality defect and merely documents the stringent testing of your Leica S.

FITTING AND REMOVING THE LENS

All lenses and accessories with Leica S bayonet can be fitted to the Leica S.

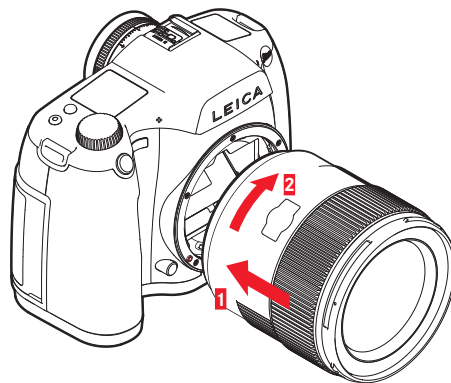

Fitting

1. Align the red dot on the lens mount with the button of the bayonet release on the camera body
2. In this position, insert the lens straight
3. Turning completely to the right causes the lens to engage audibly and tangibly

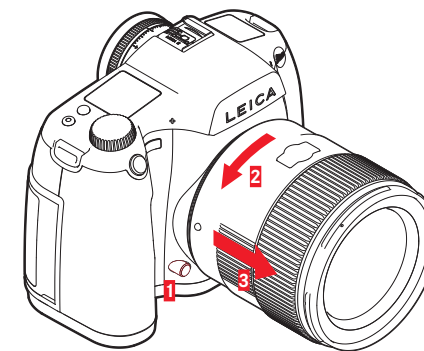

Removing

1. Press the release button
2. Release the lens by turning in anti-clockwise direction
3. Remove the lens in a straight line

Notes:

- To prevent the ingress of dust etc. into the interior of the camera, and in particular to keep the sensor surface free from dust, it is important to always have a lens or a cover fitted to the camera body.
- For the same reason, when changing lenses work quickly and in an environment that is as dust-free as possible.
- Leica also carries out firmware updates for lenses at irregular intervals. You can download new firmware from our website easily yourself to your lens. Further information can be found under "Installing firmware updates".

ADJUSTING THE EYEPIECE

The viewfinder can be adjusted from -3 to +1 diopters to adapt it exactly to your own eyesight. To do this, turn the knurled ring while observing the viewfinder image until the borders of the selective metering field are sharply focused.

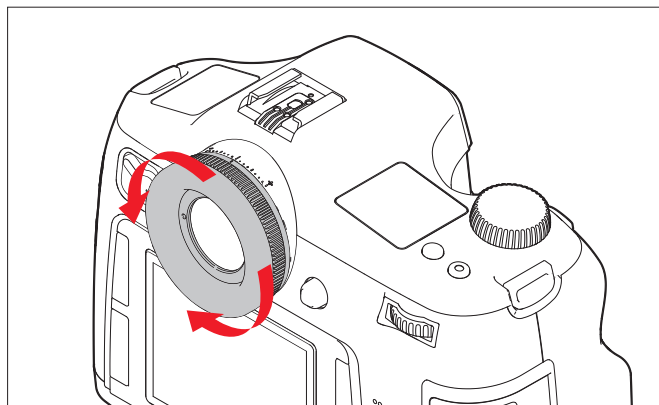

Note:

If you are not looking through the viewfinder, e.g. during recordings with a tripod, we recommend that the eyepiece cover is fitted. This prevents any influencing of the exposure metering. The cover can be stored on the carrying strap.

TURNING THE CAMERA ON AND OFF

The Leica S is turned ON and OFF using the main switch. It has three stop positions:

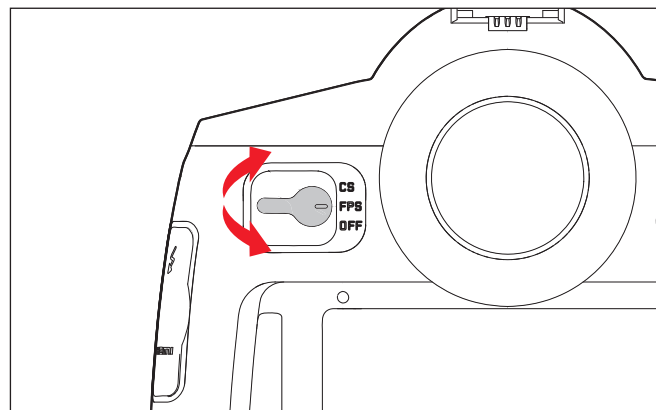

a. **OFF** - Camera turned off

b. **FPS** - Camera turned on, focal plane shutter in body in operation
 - The shutter speed is controlled via the focal plane shutter in the camera. All speeds are available (see also "Shutter speed setting dial").

c. **CS** - Camera turned on, central shutter in (correspondingly equipped) lens in operation
 - The shutter speed is controlled via the central shutter in the lens. Speeds of 8- $\frac{1}{1000}$ s are available (see also "Shutter speed setting dial").

Note:

Even when set to **CS**, the camera operates with the focal plane shutter when
 - A lens without central shutter is fitted, and/or shutter speeds of more than 8 s, or
 - less than $\frac{1}{1000}$ s are set.

After turning on, i.e. after selecting one of the two functions **FPS** or **CS**, the LED at the bottom right next to the monitor lights up until the camera is ready (2 s) and the displays appear in the viewfinder and in the top panel display.

Notes:

- Even if the main switch is not set to OFF, the camera is automatically turned off if an automatic power off time has been set in the menu and none of the controls are used in this time.
- When the camera is turned off, running functions, i.e. bracketing and self-timer operation, are aborted and also deactivated in the respective menus.

MENU CONTROL

Most of the operating modes and settings of the Leica S are operated by a menu control. Navigation and settings in the whole menu are very quick and simple as

- the menu items are divided into function groups, and
- also five user-defined menu items can be called up directly by holding the button depressed (quick access).

Controls / calling up menu control

Three of the four buttons to the left and right of the monitor are used for calling up menu control and for direct access to the function groups, namely the two buttons on the left and the lower right button.

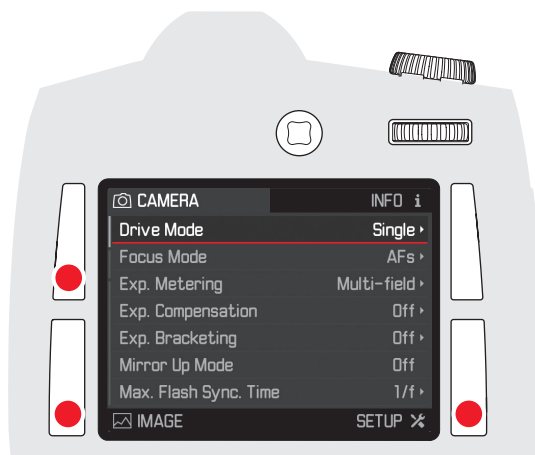

Note:

All four of these buttons are "soft keys". Outside menu control, e.g. in Live View and video mode and during the review of pictures on the monitor, they have different functions that are indicated by corresponding displays.

All settings of the menu items can also be made with the rear thumb-wheel or the Joystick.

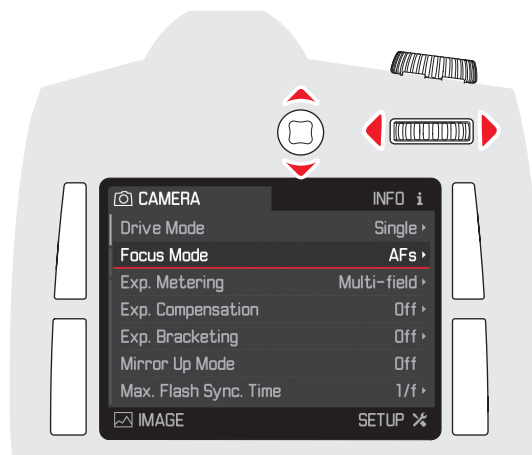

Exiting the menu

You can exit the menu in different ways:

- To switch to recording mode:
Press the shutter release or video record button, or press the Live View button
- To switch to the recorded data display:
Press the button top right - in this case marked **INFO** - briefly
- To switch to review mode:
Press the button top right while the recorded data are displayed - in this case marked **PLAY** - briefly again



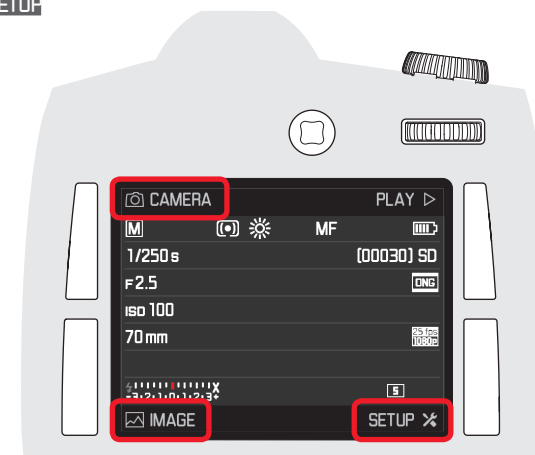

MENU FUNCTION GROUPS

The menu of the Leica S is divided into 3 function groups (see Annex "The menu items"):

- **CAMERA**
- **IMAGE**
- **SETUP**



Navigating in the menu / setting the functions

1. Select the respective menu function groups by briefly (≤ 1 s) pressing the following buttons twice:
 - Top left for the menu items of the **CAMERA** function group,
 - Bottom left for the menu items of the **IMAGE** function group, and
 - Bottom right for the menu items of the **SETUP** function group.
 - If the monitor was previously inactive (dark), the recorded data display appears when the button is pressed briefly the first time. The text boxes in the monitor image opposite the three buttons indicate the corresponding menu function groups.
 - If these are displayed from review mode, the button functions valid in this situation are first displayed in an intermediate step:
 - Top left:  (Menu)
 - Bottom left:  (Delete)
 - Top right:  (Protect)
 - Bottom right:  (Recorded data display)

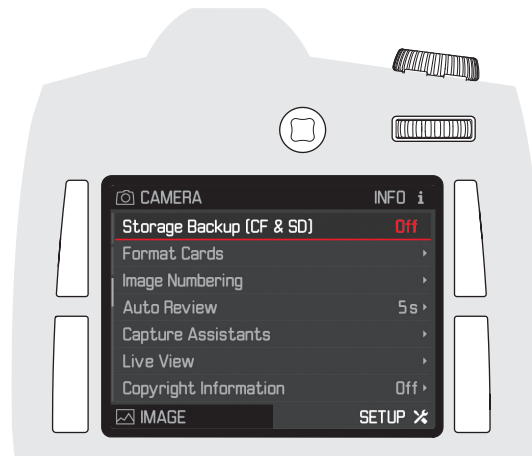
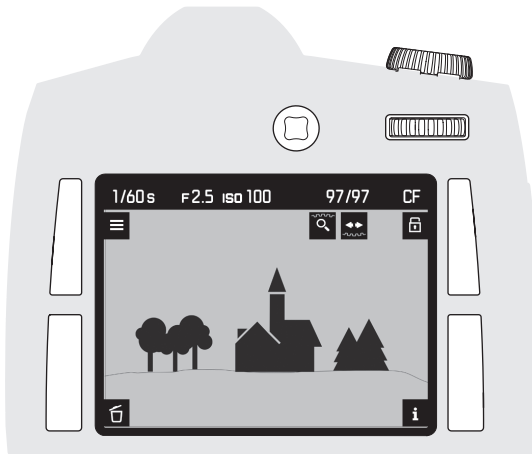

- The menu screen shows as a guide to orientation:
 - In white type the respective menu function group selected
 - In group **SETUP**, with a scrollbar on the left, which page of the list is currently displayed
 - On each page in the individual lines the menu items are displayed on the left and to the right the corresponding settings.
 - In white type with red underlining the active menu function line (this applies at all menu levels). The currently set function variant or the currently set value is always displayed to the right in the line.When the menu is called up, the last menu item changed is always active.

2. Select the individual menu items
 - either by turning the rear thumbwheel to the right = scroll down / to the left = scroll up,
 - or by pressing the Joystick in the desired direction.The menu items of all three function groups form a common endless loop, i.e. they can all be reached in both directions.

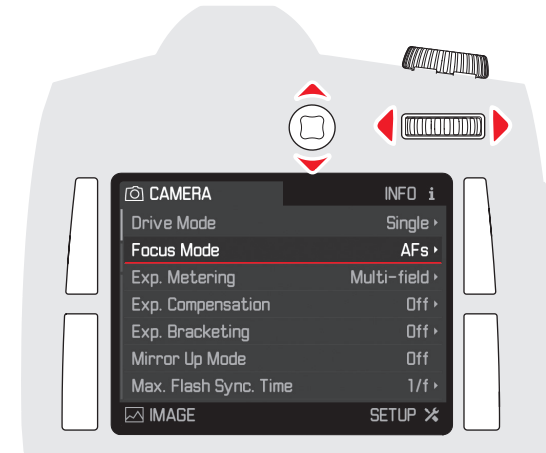

Direct setting of the menu items without sub-menu

(In the 4 menu items without a triangle at the right-hand end of the line)

3. Press the rear thumbwheel or the Joystick forwards or to the right
 - The set function variant changes. The setting is immediately active, i.e. it does not have to be confirmed.

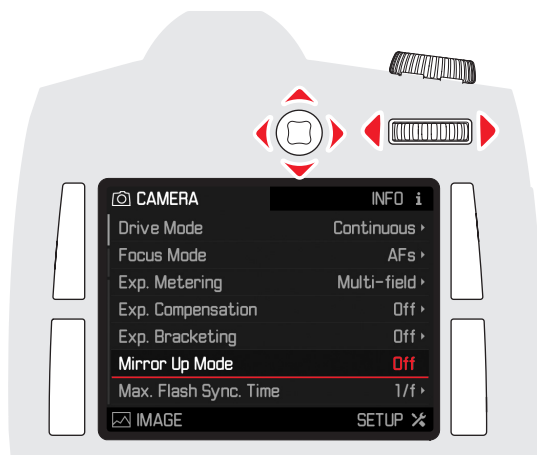

Further setting of the menu items with sub-menu

3. Press the rear thumbwheel or the Joystick forwards or to the right to call up the list of the respective function variants
 - The sub-menu in which the respective function variant or the values that can be set appears.

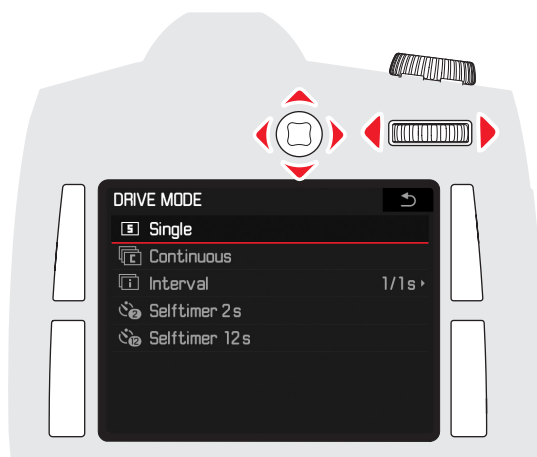

4. Turn the rear thumbwheel to the right or left or press the Joystick in the desired direction (this differs, depending on whether a list or a

scale is displayed) to select the desired function variant / the desired value

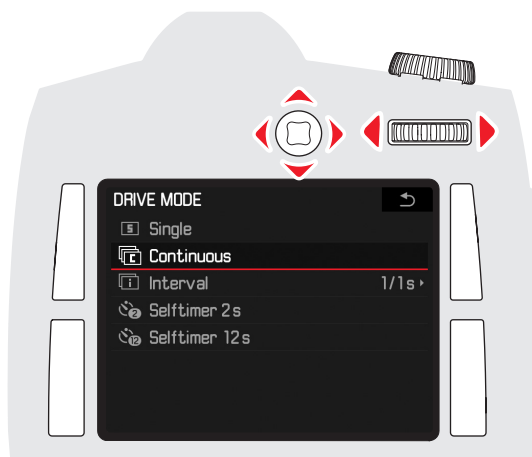

5. Press the rear thumbwheel or the Joystick forwards to confirm the set function variant / the set value
 - The display returns to the next higher menu level or switches to the next function variant for functions requiring further settings.

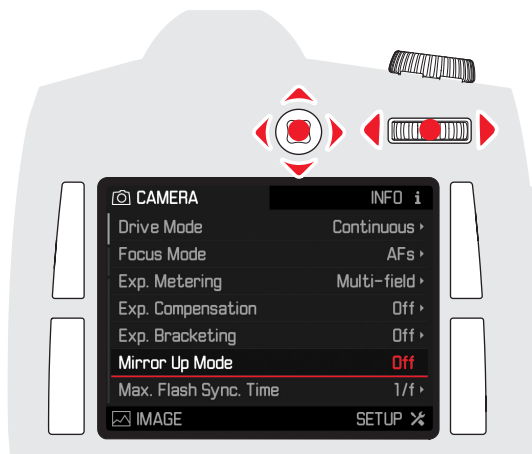

Note:

Briefly pressing the button marked  in this case allows you to return to the menu at any time – without saving the changes made in the sub-menus up to that point.

Quick access to menu functions

For particularly fast operation you can use all four buttons and, in normal photo recording mode, also the depth of field preview button to directly call up as many as 5 of the menu functions most important to you or the most frequently required menu functions.

First define which (menu) function you wish to call up with each of these buttons.

Note:

The buttons for the quick access are assigned as follows at the factory:

Button top left:

ISO

Button bottom left:

Exp. metering

Button top right:

Focus mode

Button bottom right:

Exp. compensation

Depth of field preview button:

- In normal photo recording mode: Depth of field preview
- In Live View mode: Depth of field preview plus exposure simulation
- In video mode: Access to setting the audio recording level and the headphone volume.

The functions of the depth of field preview button cannot be changed in Live View and video mode.

Setting the function / customizing the buttons

- In the menu, under **SETUP**, select the item **Customize Controls**
 - A sub-menu appears with the three items **Customize Controls**, **AF/AE Lock Button** and **Rear Wheel Direction**.

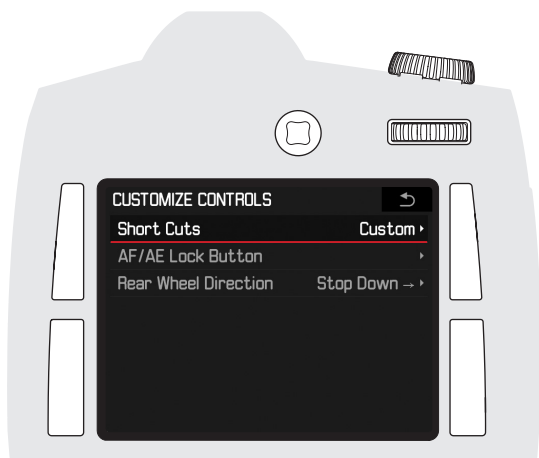

- In this sub-menu, select **Customize Controls**
 - A further sub-menu appears. If **Customize Controls** is not set to **Custom**, all the other items are inactive.

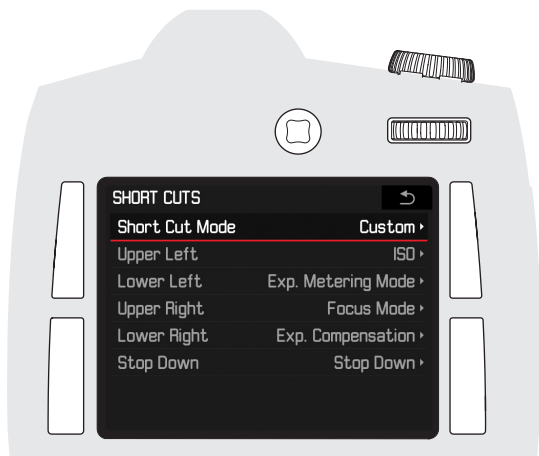

- In this sub-menu, select **Customize Controls**
 - A further sub-menu appears.

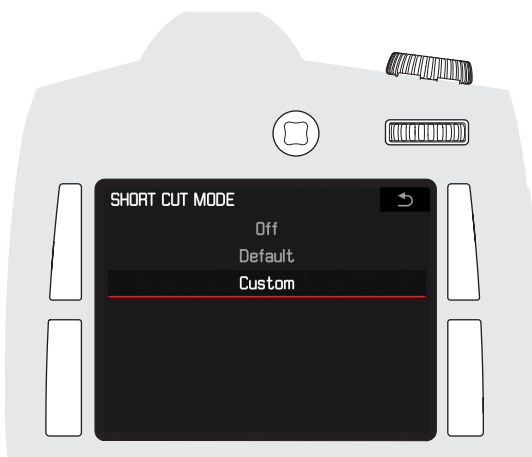

- In this sub-menu, select **Custom**
 - (or **Default** if the factory setting of the button functions is to be used, or **Off** if the function is to be deactivated)
 - The menu displayed in step 2. appears again.
- In the **Custom** sub-menu, select the desired button
 - A list with the available menu functions is displayed.

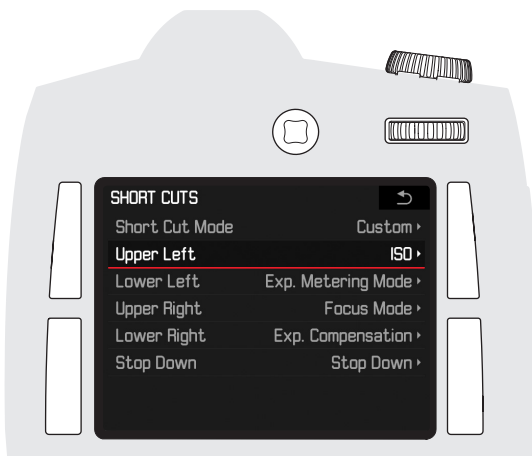

- In the respective sub-menu, select the function you wish to call up or execute directly in future with the button selected in step 5, or **Off** if you do not wish to assign a quick access to this button

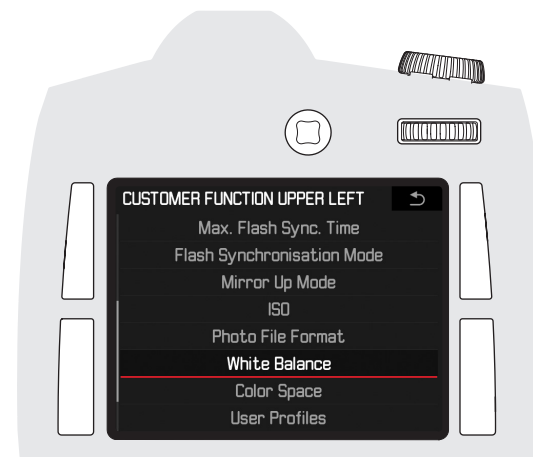

The other buttons are customized in the same way.

- The menu displayed in step 2. then appears again.

Calling up the selected menu functions

You can then call up or execute the respective set (menu) functions directly at any time and make further settings there:
 Hold the buttons alongside the monitor pressed (≥ 1 s), or in normal photo recording mode press the depth of field preview button

Note:

In Live View (photo) and video mode the depth of field preview button is assigned other functions, i.e. the quick access function that may have been set is not available in these modes. After exiting the respective operating mode, the depth of field preview button has the previously assigned function again.

PRESETS

CAMERA DEFAULT SETTINGS

Menu language

The language used in the default setting of the menu control is English. **German**, **French**, **Italian**, **Spanish**, **Russian**, **Japanese**, **Chinese Trad**, **Chinese Simp**, **Korean** and **Portuguese** can also be selected as alternative menu languages.

Setting the function

1. In the menu, under **SETUP**, select the item **Language** and
2. select the desired language in the sub-menu.
 - Apart from a few exceptions (button names, short designations), all linguistic information changes.

Date and time

Date

There are 3 options available for the sequence of the date.

Setting the function

1. In the menu, under **SETUP**, select the item **Date & Time** and
2. call up the sub-menu
3. Select **Date Setting** and call up the corresponding sub-menu
4. To change the representation, **Day/Month/Year**, **Month/Day/Year**, or **Year/Month/Day**, press the Joystick up or down or turn the rear thumbwheel with the header line active.
5. Pressing the Joystick to the left or right takes you out of the marked header line to the three setting fields below, or back to the header line.
6. In the respective marked setting field, make the settings by pressing the Joystick up or down or by turning the rear thumbwheel.
7. Confirm and save the settings by pressing the button marked **OK** in this case at the bottom right next to the monitor

Time

Setting the function

In sub-menu item **Time Setting**, the settings are made for both the numerical groups and for the representation in essentially the same way as described in the previous section for the date.

Of the other three items in the **Date & Time** sub-menu, **Auto GPS Time** and **Daylight Saving Time** are activated or deactivated by pressing the rear thumbwheel or the Joystick forward or to the right, while under **Time Zone** the desired location is selected from the list in the corresponding menu by turning the rear thumbwheel or pressing the Joystick up or down.

Notes:

- **Auto GPS Time** is only available when the GPS function is switched **on**, **Time Zone** and **Daylight Saving Time** are only available when the GPS function is switched **off**.
- Even if no battery is inserted or the battery is discharged, the date and time settings are retained for roughly three months by an integrated back-up battery (see also "Charge level displays"). After that period, however, the date and time must be set again as described above.

Auto power OFF

This function turns the camera off automatically after a preset time. This state corresponds to the main switch position **Off**.

Setting the function

1. In the menu, under **SETUP**, select the item **Auto Power Saving** and
2. set the desired time

Note:

Even if the camera is in standby mode, i.e. the displays have gone out or the activated **Auto Power Saving** function has turned it off, it can be reactivated at any time by pressing the shutter button.

Signal tones

With the Leica S you can decide whether messages or autofocus mode should be confirmed by acoustic signals, or whether the camera operation should be more or less silent. Two volumes can be selected.

The feedback is a beep tone that can be activated separately for autofocus mode to indicate the completed setting and as a signal for a message or warning.

Note:

In the factory setting the signal tones are deactivated.

Setting the functions

1. In the menu, under **SETUP**, select the item **Acoustic Signals** and
2. call up the sub-menu
It consists of the 3 items **Volume**, **AF Confirmation** and **Warnings**.
3. Under volume select **Low** or **High**
4. In the other sub-menus select whether or not you wish to activate the tones for the respective functions

If you select **On**

With AF confirmation a signal sounds as soon as the focus – whether automatic or manual – is set correctly, i.e. together with the lighting up of the corresponding display in the viewfinder.

With **Warnings** a signal sounds together with all messages and warnings displayed in the monitor, and on expiry of the self-timer.

If you select **Off** for **Warnings**

Even if you select **Off**, an acoustic warning signal is nevertheless given in two situations:

- If the cover over the memory card slots is opened during data transfer
- When the shutter closes again at the end of the sensor cleaning process

Monitor and top panel display

The Leica S has two displays,

- a black-and-white liquid-crystal display, and
- a large 3" liquid-crystal color monitor that is protected by a hard and therefore very scratch-resistant glass cover.

The top panel display shows i.a. the most important basic information on the status of the memory card(s) and the battery, and on the exposure control (see "Displays in the top panel display", p. 61).

The monitor shows the complete image field, along with the selected data and information (see "Displays in the monitor", p. 62ff). The brightness of the monitor is controlled automatically, depending on the ambient brightness. The sensor above the monitor is used for this function. Furthermore, its basic brightness can be adapted to the respective situation or to your personal wishes.

Setting the functions

1. In the menu, under **SETUP**, select the item **Display Brightness** and
2. select the desired setting in the sub-menu

Monitor



Top panel display



PICTURE DEFAULT SETTINGS

PHOTO FILE FORMAT

Two file formats, DNG and JPEG, are available for recording the picture data for photos. You can choose whether your picture data are to be saved

- in just one of these formats, or
- simultaneously in both formats (i.e. two files are always created per picture).

Setting the function

- In the menu, under **IMAGE**, select the item **Photo File Format** and
- select the desired format(s) or combination in the sub-menu

Notes:

- The standardized DNG (Digital Negative) format is used for storage of raw picture data.
- The remaining number of pictures shown in the monitor may not necessarily change after every picture. This depends on the subject; with JPEG files very fine structures result in higher quantities of data, homogeneous surfaces in lower quantities. As a result the remaining memory capacity may be larger than previously calculated and displayed.

JPEG SETTINGS

Resolution

Whereas the full resolution of 37.5 MP is always used in DNG format, two lower resolutions can also be used with the JPEG format.

Setting the function

- In the menu, under **IMAGE**, select the item **JPG Resolution** and
- select **37.5MP**, **9.3MP** or **2.3MP** in the sub-menu

Working color range

The Leica S allows one of three color ranges to be set, i.e. **sRGB**, **AdobeRGB** or **ECI RGB 2.0**.

Setting the function

- In the menu, under **IMAGE**, select the item **JPG Settings**
- then the menu item **Color Space**, and
- select the desired color range in the sub-menu

Picture properties / contrast, sharpness, color saturation

All three picture properties can be set – independently – to three different levels (with color saturation four) using the menu control, so that you can set the optimum values for any situation, i.e. the prevailing lighting conditions. In the case of **Saturation**, **Monochrome** can also be selected as a fourth variant.

Setting the functions











- In the menu, under **CAMERA**, select the item **JPG Settings** and
- call up the sub-menu
- In this sub-menu select **Contrast**, or **Sharpness**, or **Saturation**, and
- select the desired level (**Low**, **Medium**, **High** or **Monochrome**) in the respective sub-menu

WHITE BALANCE

In digital photography, white balance ensures neutral rendition of color in any light. It is based on the camera being preset to reproduce a particular light color as white. In the Leica S you can select between twelve different settings:

- AWB** (Auto) – for automatic control, which delivers neutral results in most situations,

Eight fixed presets for the most frequent light sources:

-  e.g. for outdoor pictures in sunshine,
-  e.g. for outdoor pictures with cloudy skies,
-  e.g. for outdoor pictures with the main subject in shadow,
-  e.g. for indoor pictures with (predominantly) incandescent lamp light
-  e.g. for indoor pictures with (predominantly) light from metal halide lamps (HMI)
-  e.g. for (predominantly) light from fluorescent tubes with warm light color
-  e.g. for (predominantly) light from fluorescent tubes with cooler light color
-  e.g. for pictures with (predominantly) electronic flash lighting,
- Two **Greycard** settings for manual setting by metering (separately for the Live View  and the normal photo mode 
- K** **Color Temperature**¹ – for direct setting of a color temperature value.

Note:

Setting to **Automatic** allows the white balance to be adjusted for correct color reproduction when using Leica system flash units or electronic flash units that satisfy the technical requirements of System 3002 System Camera Adaption (SCA) and have an SCA-3502 adapter (from Version 5). If, on the other hand, other flash units not specially adapted to the Leica S are used, the setting  should be used.

¹ All color temperatures are specified in Kelvin.

Setting the function

Automatic and fixed settings

1. In the menu, under **IMAGE**, select the item **White Balance** and
2. select the desired function in the sub-menu

Direct color temperature setting

You can directly set values between 2000 and 13100 (K¹) (from 2000 to 5000K in increments of 100, from 5000 to 8000K in increments of 200 and from 8000 to 13,100K in increments of 300). This provides you with a broad scope, covering most of the color temperatures occurring in practice and within which you can adapt the color reproduction to the prevailing light color and/or your personal preferences.





1. In the menu, under **IMAGE**, select the item **White Balance**.
2. in the sub-menu select the variant **Color Temperature**, and
 - A further sub-menu appears with a list in which the value to be set is indicated by the red border.
3. select the desired value there.

Manual setting by metering

1. In the menu, under **IMAGE**, select the item **White Balance** and
2. select the desired greycard variant in the sub-menu

The further procedure differs, depending on the greycard variant.



If you have selected the normal photo mode :

- The message **Please take a picture for setting the white balance** appears in the monitor.
3. Take the picture, making sure that the image field contains a white or neutral gray (reference) surface.
 - The monitor shows
 - the image based on the automatic white balance setting,
 - cross hairs in the center of the image.
 - the button functions  and  valid in this situation
 4. Press the Joystick in the desired direction to move the cross hairs to the subject detail you want to use as the basis for the new white balance setting (e.g. the reference surface mentioned above)
 5. Press the button alongside the  display, or press the Joystick forward.
 - The color reproduction of the picture is adapted accordingly and the button function  valid in this situation is also displayed.
 6. You can now either
 - either accept this new white balance setting – by pressing the button alongside the  display,
 - The message **White balance is set** appears in the monitor.
 - or make any number of further settings, as described under 3. – 6.
 - The message described under 3. appears each time in the monitor.

If you have selected the Live View photo mode :

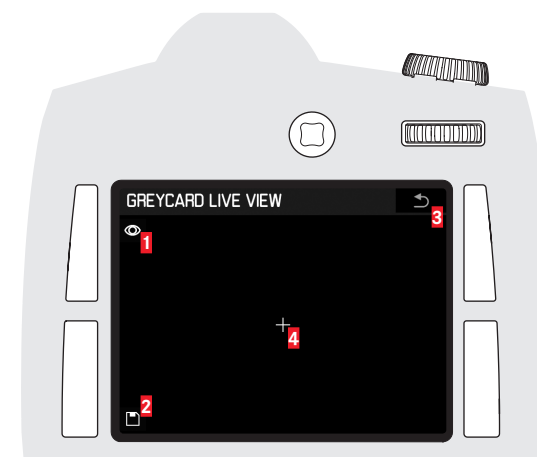
- The corresponding screen appears in the monitor.



- 1 Indication of button function: Perform white balance metering
 - 2 Indication of button function: Save white balance metering (active only after metering)
 - 3 Indication of button function: Back to normal photo mode (without saving any metered value)
 - 4 Display of the metering field
3. Move the metering field to a white or neutral gray subject detail by pressing the Joystick in the desired direction
 4. Carry out metering by pressing the  button at top left next to the monitor, or by pressing the Joystick forward
 5. Save the metered value by pressing the  button at bottom left next to the monitor
 - The camera switches back to the normal photo mode and the monitor image disappears.

Notes:

- The corresponding picture is always saved parallel to a saved white balance setting.
- A value set in this way remains saved for and will be used for all pictures until it is superseded by a new metered value or you use one of the other white balance settings.

ISO sensitivity

The ISO setting on the Leica S allows a manual adjustment of the shutter speed/aperture values to the needs of the particular situation.

As well as the fixed settings, the Leica S also features the **ISO Auto**¹ function, in which the camera automatically adjusts the sensitivity to the ambient brightness. When using the function, however, it is also possible to specify priorities, for example for compositional reasons. You can both limit the range of sensitivities used and set the shutter speed below which the sensitivity is automatically increased.

Notes:

A general rule of thumb in digital photography is that higher sensitivities result in increased noise. This has to be taken into consideration for the expectations on the picture quality.

Note with picture series that the frame rates decrease with higher sensitivities.

Setting the function

1. In the menu, under **IMAGE**, select the item **ISO** and
2. call up the sub-menu
It consists of the available ISO values and the point **ISO Auto**.

If you wish to set the sensitivity manually

3. select the desired value

If the sensitivity setting is to function automatically and without limitations

4. select **ISO Auto**
The automatic setting uses all sensitivities and shutter speeds between $\frac{1}{2}$ s and $\frac{1}{500}$ s

To restrict the automatic setting range

1. In the menu, under **SETUP**, select the item **Auto ISO Setup** and
2. select **Auto ISO Photo** in the sub-menu

3. Select **Maximum Auto ISO** and/or **Maximum Exposure Time**
 - When setting **Maximum Auto ISO**, a list with the available values appears, when setting **Maximum Exposure Time** a further sub-menu with several alternatives.
4. In the **Maximum AUTO ISO** menu list, select the highest sensitivity to be used, and hence the range within which the automatic setting is to operate, or in the **Maximum Exposure Time** sub-menu set either one of the three focal length-specific settings - $\frac{1}{f}$, $\frac{1}{2f}$, $\frac{1}{4f}$ or the desired slowest shutter speed. With the $\frac{1}{4f}$ settings the camera switches to the higher sensitivity if the shutter speed would drop below the selected threshold due to a lack of brightness, e.g. with a 70 mm lens with shutter speeds lower than $\frac{1}{60}$ s (with $\frac{1}{4}$ (f=focal length)), or $\frac{1}{125}$ s with $\frac{1}{2f}$, or $\frac{1}{250}$ s with $\frac{1}{4f}$ *.

Note:

The factory setting of $\frac{1}{2f}$ results in the slowest shutter speeds according to the rule of thumb adapted for this format for blur-free pictures taken from the hand, e.g. $\frac{1}{125}$ s with the Summarit-S 1:2.5/70mm ASPH lens. The corresponding shutter speeds with $\frac{1}{2f}$ and $\frac{1}{4f}$ in this example would be $\frac{1}{60}$ s and $\frac{1}{250}$ s.

¹ The function is not available when using flash units.

Storage of picture data / memory card management

If two memory cards are used, you have the possibility with the Leica S to choose

- whether the picture data should first be stored on one of the two cards until its capacity is reached, and then on the other card, or whether the data should
- always be stored simultaneously on both cards.

Setting the function

1. In the menu, under **SETUP**, select the item **Storage Backup (CF & SD)** and
2. there select **Off** or **On**

Note:

If **Off** is selected:

- The picture data are first stored on the SD/SDHC/SDXC card and then once its capacity is reached on the CF card. As soon as the camera is connected to a computer, it stores the picture data only in the specified folder on the computer.

If **On** is selected:

- The picture data are stored simultaneously on both cards.

With both settings:

- If only one card is used (irrespective of which), the picture data are stored there.

As soon as the camera is connected to a computer, it stores the picture data on a card and also in the specified folder on the computer.

RECORDING MODE

FOR PHOTOS

SHUTTER BUTTON

- Pressing briefly activates the range and exposure metering systems, and the displays in the viewfinder and top panel display. When the shutter button is released, the metering systems remain active for approx. 12 s.

Notes:

- If Review mode was previously active, the camera switches back to Recording mode when the shutter button is pressed; if it was previously in Stand-by mode, it is activated again by pressing the shutter button, i.e. the metering systems and displays are activated.
- The shutter button remains blocked
 - if the internal buffer memory is temporarily full, e.g. after a series of pictures, or
 - if the inserted memory card(s) is/are full.
- Pressing the shutter button to the pressure point and holding in this position when using Autofocus **AFS** mode (focus priority), the focus is saved at the same time. New measurements can be performed once the shutter button is released.

Note:

The metered exposure value during spot and center weighted metering in **A**, **T** and **S** modes is saved, if required, by (simultaneously) pressing the Joystick forwards. Automatic focusing can also be allocated to the Joystick via the menu control.

- If the button is pressed further, the photo is taken or a preselected self-timer delay time starts.

PICTURE SERIES

With the Leica S, the picture series can be taken with a frame rate of approx. 3.5 fps.

Setting and using the function

- In the menu, under **CAMERA**, select the item **Drive Mode** and
- select **Continuous** in the sub-menu
- The further function is then determined by the different actuation of the shutter button:
 - Picture series are taken as long as you hold the shutter button fully depressed (and the capacity of the buffer memory and/or memory card(s) is sufficient).
 - If you only fully depress the shutter button briefly, the camera continues to take single pictures.



INTERVAL SHOOTING

For picture series of sequences extending over a prolonged period of time, the Leica S offers interval shooting.

Intervals consist of a defined total number of pictures and a defined period of time between the pictures.

Setting and using the function

- In the menu, under **CAMERA**, select the item **Drive Mode** and
- select **Interval** in the sub-menu
- Call up the sub-menu belonging to the interval and
- there select **Frames** or **Interval Time**
 - In both cases a further sub-menu appears with a numerical keypad. The activates field is highlighted in each case.
- Select the (first) desired digit by turning the rear thumbwheel or by pressing the Joystick up, down, to the left or to the right; in the **Frames** sub-menu for the total number of pictures, in the **Interval Time** sub-menu for the desired time interval between the individual pictures – in hours/minutes/seconds.

- To save a digit – to the line above the numerical keypad – press the rear thumbwheel or the Joystick forwards. Up to 4-digit numbers can be used; repeat steps 5. and 6. for the second, third and fourth digits. Further functions of this sub-menu:
 -  (top right) = Back to the previous menu level without saving the inputs
 -  (bottom right) = Confirm inputs and return to the previous menu level
- Confirm your settings by pressing the button marked **SET** in this case at the bottom right next to the monitor

Note:

If step 7. is performed without entering a digit in the line, the camera automatically sets the numbers of the factory setting.

- Interval shooting is started by pressing the shutter button.

Note:

The function remains active until it is deactivated again in the menu.

Notes that apply equally for photo series and interval shooting:

- The camera's buffer memory allows only a limited number of pictures in series. At the pressure point of the shutter button or during a series of pictures, the number of pictures possible or still possible in the series is displayed in the viewfinder.
- Regardless of how many pictures have been taken in a series, both review modes initially show the last picture in the series or the last picture in the series saved on the currently active card, if not all of the pictures in the series have been transferred from the internal buffer memory to the respective card yet. Details of how to select the other pictures in the series and further options in review mode are described in the respective sections.

Live View mode

Whereas the conventional photography mode presupposes use of the camera viewfinder, Live View mode permits continuous viewing of the subject on the monitor, i.e. both before and during recording.

Live View mode is switched on and off, and video mode is switched on (without starting recording) with the **LV** button. Pressing the button displays the functions in turn (in an endless loop)

Live View photo / video mode / conventional photography mode

- When switched on, the functions of the adjacent buttons are displayed for 3 seconds in the four corners of the monitor picture.
- Video mode is always performed using the monitor picture.

Notes:

- Additional autofocus and exposure metering function variants can be used during Live View mode, see the corresponding sections.
- Live View mode is based on the image captured by the sensor. To use it, the shutter must be open and it is closed and re-cocked when the function is canceled. Of course, this is audible and may result in a delay in the shutter release.
- Frequent use of the Live View mode results in increased power consumption.

Exposure simulation







In the factory setting, the Live View monitor picture shows the subject in the brightness resulting from the respective exposure setting. This exposure simulation allows the effect on the picture to be assessed before the photograph is taken, e.g. during exposure corrections or during manual setting of the exposure. With automatic exposure control (**P**, **A**, **T**, see p. 30/31), on the other hand, the monitor picture generally remains equally bright, i.e. within the respective setting ranges.

The exposure simulation can be deactivated by pressing the depth of field preview button so that you generally get a monitor picture with constant brightness, irrespective of the exposure settings.

The "generally" constant brightness presupposes, however, that the subject brightness and the set exposure do not result in any excessively high or low brightness values, and that the internal exposure time is not longer than $\frac{1}{30}$ s.

Displays in Live View mode

With the standard setting, the Live View monitor picture contains the following displays (see "The displays / In the monitor / Recording mode Live View photo", p. 62):

- In the header some fundamental information
- In the corners of the picture, symbols for the functions of the buttons alongside the monitor:  = Review,  = Change of display,  = Magnify and  = Menu
-  Spot autofocus metering field (+ autofocus metering crosshair)
-  Autofocus metering crosshair
- Exposure simulation
- or  = Button lock

Display settings

Repeatedly pressing the button bottom right next to the monitor calls up various additional displays/information in turn:

- Histogram and clipping indicators
- Marking of clearly focused subjects
- Grid lines and horizon
- Extended picture data
- Back to the normal view

Histogram

The histogram depicts the brightness distribution in the picture. The horizontal axis shows the brightness values from black (left) through gray to white (right). The vertical axis corresponds to the number of pixels at each brightness level. This form of representation – together with the impression of the picture itself – provides an additional quick and easy assessment of the exposure setting.

Clipping displays

These displays indicate the picture areas without marking.

Setting the function

1. In the menu, under **SETUP**, select the item **Capture Assistants** and
2. select **Exposure Clipping** in the sub-menu
3. In the sub-menu select **Lower Limit** or **Upper Limit**, and
4. set the desired threshold values on the scale by turning the rear thumbwheel or by pressing the Joystick to the left or right
 - The scale shows the clipping areas relative to the overall exposure range.

The following then appears in the pictures:

- Excessively light areas are indicated in red, excessively dark areas in blue, flashing in each case. The clipping symbol ([]) also appears in the top right corner.

Notes on the histogram and the clipping indicators:

- Both are available also in Review mode.
- Both always refer to the currently displayed detail (see "Enlarging the Live View monitor image").

Marking of clearly focused subjects (focus peaking)

In Live View mode, the Leica S can mark subjects imaged with optimum focus in the monitor picture by highlighting their contours. This simplifies their recognition and hence in particular the manual setting of the focus. The three available colors permit adaptation to any background.

Setting the function

1. In the menu, under **SETUP**, select the item **Capture Assistants** and
2. select **Focus Peaking** in the sub-menu
3. Call up the sub-menu, and
4. select the desired color there
 - All subject details that are in focus at the set range are indicated by outlines in the selected color.

Further information on setting the focus can be found in the corresponding sections.

Note:

When using high ISO values and/or slow shutter speeds, the function may not work.

Important:

This function is based on the subject contrast, i.e. light/dark differences. Therefore, subject details that are not completely in focus but have a high contrast may also be marked.

Grid

The Leica S offers you two variants of grid lines as an aid to picture composition.

Setting the function

1. In the menu, under **SETUP**, select the item **Capture Assistants**,
2. select **Grids** in the sub-menu, and
3. select **3x3** or **6x4** in the sub-menu
 - If the view with horizon and grid is selected, the selected grid is displayed in the monitor.

Horizon

Thanks to integrated sensors, the Leica S can show their orientation both in the viewfinder and on the monitor. These displays enable you to align the camera precisely in the longitudinal and transverse axes to capture critical subjects, e.g. architecture pictures.

The corresponding display always appears in the viewfinder, on the monitor as required.

- If the view with horizon and grid is selected, a vertical scale and a horizontal bar appear in the monitor. The horizontal orientation in the longitudinal and transverse axes is indicated by a green line in the middle, deviations from the respective zero positions by red dotted lines.

Notes:

- The display precision is $\leq 1^\circ$.
- The display switches over automatically for portrait format pictures.

Masking

In addition to the standard aspect ratio (2:3) for photos, three further ratios are available when using the DNG format: 1:1, 16:9, 2:1. They open up further composition possibilities while taking the picture.

Setting the function

1. In the menu, under **SETUP**, select the item **Capture Assistants**,
2. select **Photo Masks** in the sub-menu, and
3. select the desired format there
 - The monitor picture is masked accordingly, with 1:1 left and right, with 16:9 and 2:1 top and bottom. While taking the photograph the mask is transparent, during review of corresponding photos in the camera it is not.

Note:

Irrespective of the aspect ratio selected, the whole 2:3 image field is always recorded, i.e. the masking of the monitor picture affects only the display in the camera. Although the photo is initially displayed with the selected aspect ratio in image processing programs, it is possible to delete the masking there so that the whole 2:3 image field is available again.

Enlarging the Live View monitor image

Select differently enlarged details:

Press the button bottom left next to the monitor repeatedly

- This gives in turn
 - Double the size
 - Four times the size
 - Back to normal size
- The buttons are not displayed with the enlarged view; a frame appears in the bottom left-hand corner that indicates the position of the detail in the picture.

Shift the detail:

Press the Joystick left, right, up or down

Notes:

- The grid line display is not available with the enlarged view.
- After switching Live View mode off and on again, the last displays selected are active again, but not the enlarged detail.
- Switching the camera off and on again displays the last detail selected.

DISTANCE SETTING

With all S lenses, the Leica S offers you the choice between manual or automatic distance setting. The autofocus system determines the distance to the subject details in the middle of the image field; this area is marked with a crosshair on the focusing screen and, in Live View mode, also in the monitor.

Irrespective of the operating mode, a display in the viewfinder provides information on the respective setting:

- The left-hand triangle indicates the focus set too long (appears only in Manual mode or with manual override of the autofocus) - The middle dot shows a correct setting (is lit constantly), or if the system cannot determine the distance (flashes)
- The right-hand triangle indicates the focus set too short (appears only in Manual mode or with manual override of the autofocus) Further details on the displays can be found in the Annex under "The displays" / "In the viewfinder".

Note:

The metering system operates passively on the basis of contrasts, i.e. differences in light/dark in the part of the subject being photographed. It is therefore dependent on a certain minimum brightness and contrast in the subject.

Setting the operating mode

1. In the menu, under **CAMERA**, select the item **Focus Mode** and
2. select the desired option in the sub-menu

Manual setting - MF

Turn the distance setting ring on the lens so that your subject or the most important part of the subject is fully in focus on the focusing screen or, in Live View mode, on the monitor.

- In the top panel display, the distances for the set focus (**FOCUS**), and for the front (**FRONT**) and rear (**BACK**) limits of the depth of field range are displayed when the shutter button is pressed to the pressure point.

In Live View mode you can call up an enlarged detail as a setting aid.

1. In the menu, under **SETUP**, select the item **Capture Assistants**,
2. select **Manual Focus Assist** in the sub-menu, and
3. select **On** or **Off** there
 - If the function is activated, a central detail magnified 4x is displayed briefly each time the setting ring on the lens is turned. The detail can be moved using the Joystick.

Notes:

- Autofocus mode can be activated at any time also with manual setting of the focus using the Joystick (see next section and the section on the function of the Joystick on page 32).
- The Leica S is supplied as standard with a full matt screen with which subject details can be reliably focused sharply over the whole image field. It is suitable for most photographic fields of application and motifs. It is particularly beneficial when working with longer focal lengths and for macro photography. Further focusing screens are available as accessories which offer optimum setting conditions, depending on the field of application, and are easy to change.

AUTOMATIC SETTING

Two autofocus modes are available. The setting procedure for both is initiated by tapping (1st pressure point) the shutter button.

AFs (single) = focus priority

The part of the subject you are aiming at will come into focus.

- After that, the process ends and the setting is saved even if you continue to hold the shutter release button at the first pressure point.
- It is not possible to take a picture before it comes into focus, even if the shutter button is pressed all the way down.

Note:

An AF setting can be stored not only with the shutter button, but also with the Joystick.

AFc (continuous) = shutter release priority

The parts of the subject being photographed are fully focused.

- The process continues as long as the shutter release button is held at the first pressure point. While the button is being held down the camera's settings are corrected, so other objects at other distances may be recognized by the metering system, or if the distance to the camera of the part of the subject being photographed changes.
- A setting can only be saved by pressing the Joystick forwards.
- Even if no part of the subject is in focus, a picture can be taken at any time.

Note:

AFc is not available in Live View mode.

With both AF operating modes:

You can intervene manually at any time even during autofocus mode by turning the setting ring on the lens.

- In Live View mode the color of the metering crosshair in the monitor changes from red to green when the focus has been correctly set.

Moving the autofocus metering field in Live View mode

In Live View mode, the metering field can be moved to any point of the image field with the Joystick.

In the two enlarged details, the detail is first moved together with the metering field that remains in the middle. Only when the detail reaches the edge of the image field can the metering field be moved to the edge of the detail by pushing further.

Note:

If Spot is used as exposure metering method in Live View mode, its metering field is coupled to that of the autofocus, i.e. both metering fields are then moved.

EXPOSURE METERING

EXPOSURE METERING METHODS

The Leica S offers three different exposure metering methods.

Setting the function

1. In the menu under **CAMERA**, select the item **Exp. Metering**, and
2. select the desired option in the sub-menu

Spot metering -

Only the middle of the image field is scanned and evaluated for spot metering. This area is indicated by the circle¹ in the center of the matt screen. In Live View mode, spot metering is linked to the autofocus metering, i.e. moving the AF metering point also affects the spot metering field.





Center weighted metering -

This metering method takes account of the entire image field, although the parts of the subject in the center have more influence on the exposure than the areas at the margins.

Multi-field metering -

This metering method is based on detection of five metered values. One is metered in a field in the middle of the image, the other four in the surrounding fields. The five metered values are used in an algorithm to calculate an exposure value appropriate to the situation, resulting in correct reproduction of the assumed main subject.

EXPOSURE CONTROL

The four exposure modes automatic program () , aperture priority () , shutter speed priority () and manual exposure control () are selected on the Leica S with the rear thumbwheel:

Setting the operating mode

1. Hold the thumbwheel depressed (≥ 1 s)
 - In the top panel display, the large letter indicating the set operating mode replaces the normal display. Triangles to the left and right indicate the further settings.
2. Turn the thumbwheel (all four operating modes can be reached in both directions)
 - The normal display appears again in the top panel display without further operating steps after a short time (approx. 2 s), or immediately if the shutter button is pressed to the pressure point. The settings of shutter speed and aperture are made by turning the rear thumbwheel and/or the shutter speed setting dial. In both cases half-steps are available.

The settings for the shutter speed (with **T** and **M**) are always made with the shutter speed setting dial, for the aperture always with the rear thumbwheel. In both cases half-steps are available.

In the factory setting, turning the rear thumbwheel to the right decreases the aperture settings, turning to the left increases the settings. This can be reversed, if desired.

Setting the function

1. In the menu, under **SETUP**, select the item **Customize Controls** and
2. select **Rear Wheel Direction** in the sub-menu
 - A further sub-menu appears.
3. In this sub-menu, select the desired direction of rotation

The function of both thumbwheels can be deactivated for complete protection against inadvertent changing of operating mode, shutter speed, aperture, etc., i.e. turning and pressing do not then change the settings in recording mode.

Setting the function

1. In the menu, under **SETUP**, select the item **Keylock** and
2. select **Off** or **On** in the sub-menu
 - If **On** is selected, the corresponding symbol appears in the top panel display, and in Live View mode also in the monitor

AUTOMATIC PROGRAM MODE - P

Exposure time and lens aperture are automatically set according to the prevailing light and steplessly between 125 s and $\frac{1}{4000}$ s, or $\frac{1}{1000}$ s when using the central shutter on some Leica S lenses, and between open and smallest aperture of the respective lens.

Displays in viewfinder and top panel display

-  for the selected exposure operating mode, and
- the automatically controlled shutter speed and aperture values.

Notes:

- If the automatic sensitivity setting (**AUTO ISO**) is activated at the same time, the control range of automatic program mode is extended. Even with fully open aperture, however, the shutter speed is only extended beyond the value dictated by the 1/f¹ setting selected in the menu when the highest set sensitivity is reached.
- With very little light or extreme brightness it is possible that the available shutter speed range is no longer sufficient for the preselected aperture value. In such extremely rare cases a warning symbol for underexposure appears in the viewfinder (possibly also as a warning of values below the metering range, see also "Values below the metering range"), or a warning symbol for overexposure. Correct exposure metering is then no longer possible.

¹ The circle does not exist in all matt screen variants.

¹ Applies also for $\frac{1}{4}$, $\frac{1}{2}f$ and $\frac{1}{4}f$

PROGRAM SHIFT

Setting the operating mode

Select **P** with the rear thumbwheel

The program shift function allows the speed/aperture combinations determined in automatic program mode to be changed, while the overall exposure, i.e. the brightness of the image, remains unchanged. The shift is performed with the shutter speed setting dial.

- to the right for larger apertures (smaller values) or faster shutter speed
- to the left for smaller apertures (larger values) or slower shutter speed.

Displays in viewfinder and top panel display, and in Live View mode also in the monitor

- **P** in the top panel display as an indication of the use of the Shift function, and
- the operating mode display **P** in the monitor changes to **P**.
- the automatically controlled aperture and speed values change in opposite directions.

Note:

Shift settings are retained

- after a photo is taken,
 - beyond the 12 s holding time of the exposure metering system, but not
 - when changing to a different exposure operating mode (**A**, **T**, **M**)
 - when the camera is switched off and on (also by **Auto Power Saving**).
- In these cases the camera always returns initially to the standard setting of shutter speed and aperture when automatic program mode is used again.

APERTURE PRIORITY - A

Setting the operating mode

1. Select **A** with the rear thumbwheel (see also p. 30, "Exposure control")
2. Set the desired aperture by turning the rear thumbwheel. The exposure time is then automatically set according to the prevailing light and steplessly between 1/25 s and 1/4000 s, or 1/1000 s when using the central shutter on some Leica S lenses.

Displays in viewfinder and top panel display, and in Live View mode also in the monitor

- **A** (Aperture priority) for the selected exposure mode,
- the manually set aperture value, and
- the automatically controlled time value.

Notes:

- If the automatic sensitivity setting (**ISO Auto**) is activated at the same time, the control range of aperture priority is extended. However, the shutter speed is only extended beyond the value dictated by the 1/ setting selected in the menu when the highest set sensitivity is reached.
- With very little light or extreme brightness it is possible that the available shutter speed range is no longer sufficient for the preselected aperture value. In such extremely rare cases a warning symbol for underexposure appears in the viewfinder (and possibly also a warning of values below the metering range, see also "Values below the metering range"), or a warning symbol for overexposure. Correct exposure metering is then no longer possible.
- In video mode the slowest shutter speeds are dependent on the set frame rate.

SHUTTER SPEED PRIORITY - T

Setting the operating mode

1. Select **T** with the rear thumbwheel (see also p. 30, "Exposure control")
2. Set the desired exposure time with the shutter speed setting dial. The lens aperture is then automatically controlled according to the prevailing light and steplessly between open and smallest aperture of the respective lens.

Displays in viewfinder and top panel display, and in Live View mode also in the monitor

- **T** (Time priority) for the selected exposure mode
- the automatically controlled aperture value
- the manually set time value

Notes:

- If the automatic sensitivity setting (**ISO Auto**) is activated at the same time, the control range of shutter speed priority is extended. A minimum shutter speed that may have been set there, however, is no longer active.
- With very little light or extreme brightness it is possible that the available aperture range of the lens used is no longer sufficient for the preselected shutter speed. If possible, select a different shutter speed.
- As a rule, however, correct exposure can be achieved with an automatic setting of the appropriate shutter speed even in such cases, by "overriding" your manual preselection. A warning symbol appears, possibly also as a warning of values below the metering range, see also "Values below the metering range". Correct exposure metering is then no longer possible.
- If (=1/25s) is set with the shutter speed setting dial, the camera switches to **M** (see p. 33). As soon as another shutter speed is set, it switches back to **T**.

METERING MEMORY LOCK

The shutter button and/or the Joystick can be used to save the exposure setting (for **P**, **A** and **I**) and the automatic focus (**AF**), depending on the various menu settings.

General notes on the storage function

– With the shutter button:

- Only the **AF** setting can be stored, and only in **AFs** operating mode.
- The storage function of the shutter button always applies to only one picture.

– With the Joystick:

- The exposure and **AF** settings can be stored. Various function combinations are available which you define via the menu control.
- The storage function of the Joystick is retained as long as it is held pressed forward, i.e. over any number of pictures, and irrespective of whether the shutter button is also pressed at the same time.
- The storage function of the Joystick applies to both the **AFs** and the **AFc** operating mode.

Saving with the shutter button

1. Focus on the part of the subject to be metered with the crosshair¹ in the viewfinder
2. Press the shutter button to the first pressure point. The value stored is retained as long as this pressure point is held.
3. While holding the pressure point, determine the final picture detail and take the
4. picture.

Metering memory lock is canceled when you remove your finger from the shutter button pressure point.

Saving with the Joystick

Setting the function combinations

1. In the menu, under **SETUP**, select the item **Customize Controls** and
2. select **AF/AE Lock Button** in the sub-menu
 - A further sub-menu appears.

In this sub-menu select whether you wish to set the function for **In AF Mode** or **In MF Mode** set via the menu

In AF mode

3. In the **AF-Mode** sub-menu, select one of the three variants

Effect of the three function variants:

- **AF/AE lock** (factory setting)
 - Shutter release button: **AFs** setting
 - Joystick: Exposure setting, **AFs/AFc** setting
- **AE-L**
 - Shutter release button: **AFs** setting
 - Joystick: Exposure setting
- **AF-L**
 - Shutter release button: **AFs** setting
 - Joystick: **AFs/AFc** setting

In MF mode

In manual focus mode you can nevertheless activate AF mode temporarily, i.e. for the particular picture, and/or – depending on the setting - to save the exposure setting by pressing the Joystick forwards.

3. In the **MF-Mode** sub-menu, select one of the five variants

Effect of the five function variants

- **AFs On / AE Lock** (factory setting)
AFs mode activated for one picture, saving of the exposure setting
The resulting AF setting remains stored until it is changed by manual adjustment or by pressing the button again.
- **AFs on**
- As for **AFs On / AE Lock**, but without saving of the exposure setting
- **AFc On / AE Lock**
As for **AFs On / AE Lock**, but with **AFc** mode
- **AFc on**
As for **AFs On / AE Lock**, but without saving of the exposure setting
- **AE-L**
Saving of the exposure setting

Displays in the viewfinder during saving of the exposure setting

- A light balance appears showing the deviation from the stored metered value.
- If aperture and/or exposure time are changed during this time, the respective other value is adapted accordingly and displayed.

EXPOSURE COMPENSATION

Exposure compensations are possible in automatic program, shutter speed priority and aperture priority modes.

Entering and canceling an exposure compensation in the menu

1. In the menu under **CAMERA**, select the item **Exp. Compensation**.
 - The sub-menu shows a scale with a setting mark highlighted in red. If it is at a value of **0**, this means that the function is deactivated.
2. Set the desired value by turning the rear thumbwheel or by pressing the Joystick to the left or right.
 - In the initial menu list, a set compensation is indicated by **EV+X¹**

Note:

In the factory setting, this function can be called up directly by holding the button bottom right next to the monitor depressed.

Displays in viewfinder and top panel display, and in Live View mode also in the monitor (in the picture data display)

- The compensation value on the light balance (viewfinder and monitor)
- A corresponding warning symbol (viewfinder)
- **EV** or **EV** (top panel display)

Notes:

- Once set, a compensation value is retained even when the camera is switched off.
- An exposure compensation set on the camera only influences metering of the available light, i.e. not flash light (for more information about flash photography, refer to the respective sections).

¹ Example, either plus or minus, "X" stands for the respective value

MANUAL SETTING OF APERTURE AND EXPOSURE TIME - M

Setting the operating mode

1. Select **M** with the rear thumbwheel (see also p. 30, "Exposure control")
2. Set the desired aperture by turning the rear thumbwheel and the desired exposure time with the shutter speed setting dial

Displays in viewfinder and top panel display, and in Live View mode also in the monitor

- **M** for the selected exposure operating mode,
- The manually set aperture and shutter speed values, and
- A light balance with which the exposure compensation is performed. The light balance shows the deviation of the shutter speed/aperture combination just set from the metered exposure value. In the range of ± 3 EV, the deviation is shown clearly in $\frac{1}{2}$ EV steps. Larger deviations are indicated by flashing of the outer mark of the light balance.

For correct exposure according to the exposure meter, vary the aperture and/or speed until only the zero mark of the light balance lights up.

Note:

If the automatic sensitivity setting (**ISO Auto**) is activated at the same time, the last manually set sensitivity is used. A minimum shutter speed that may have been set, however, is not active.

BRACKETING

Bracketing can be employed with all four exposure operating modes.

The following are available:

- 2 numbers of pictures: 3 or 5
- Graduations: 0.5EV, 1EV, 2EV and 3EV

Setting the function

1. In the menu under **CAMERA**, select the item **Exp. Bracketing**
 - The sub-menu appears on the monitor with the four items **Exp. Bracketing**, **Frames**, **F-Stops** and **Automatic**, and below this a scale. If an exposure compensation is set at the same time, this is indicated by a corresponding value below the scale.
2. For **Exp. Bracketing**, turn the rear thumbwheel or press the Joystick to left or right to select whether you wish to carry out bracketing (**On**) or not (**Off**)
 - If **On** is selected, the other three sub-menu items are activated (= white).
3. Press the rear thumbwheel or the Joystick forward to call up the next sub-menu item (the same applies to all sub-menu items)
4. In **Frames**, set the number of frames, and in **F-Stops** the desired exposure graduations between the pictures of the series
 - The selected exposures are displayed in red on the scale. An exposure compensation that may be set is recognizable from the fact that the whole series around the compensation value is "off-set" from the middle of the scale.
5. In **Automatic**, select whether you wish to trigger the pictures individually yourself (**Off**), or whether the pictures should all be taken in series when the shutter button is pressed once (**On**)
 - A set exposure series is indicated in the initial menu list by **X/Y EV**.
6. All pictures are produced by pressing the shutter release button once or several times.

Note:

The function **Exp. Bracketing** is not available if an interval shooting series has previously been set.

Displays in the viewfinder

- A warning symbol
- The changing displays for shutter speed and aperture corresponding to the graduations

Displays in the top panel display

- Next to the exposure mode in front of the overexposure(s) **+**, in front of the uncorrected picture **0**, in front of the underexposure(s) **-**
- A symbol indicating an exposure series

Displays in the monitor (in the picture data display)

- A symbol indicating an exposure series

THE B SETTING

With the B setting, the shutter remains open as long as the shutter button is held depressed (max. 125 s).

Display in the viewfinder

- **bulb** instead of a shutter speed

Display in the top panel display

- **B**
- After opening of the shutter, the running exposure time

Displays in the monitor in Live View mode

- **bulb** instead of a shutter speed

In conjunction with the self-timer, a T function is also available: If both **B** is set and the self-timer is activated by pressing the shutter release button, the shutter opens automatically after the selected delay time. It then remains open until you press the shutter release button a second time – you do not need to hold the button down. This enables you to largely prevent any blurring, even with long exposures, by pressing the shutter release button. In both cases the exposure meter remains deactivated.

¹ "X" stands for the number of pictures, "Y" for the graduation

Notes:

- Depending on the exposure mode, the exposure graduations are created by changing the shutter speeds and/or apertures.
- The sequence of the exposures is: Overexposure(s), correct exposure, underexposure(s).
- When using automatic bracketing, all **ISO Auto** settings are fixed:
 - The sensitivity automatically determined by the camera for the uncorrected picture is also used for all other pictures in a series, i.e. this ISO value is not changed during a series.
 - The settings in the **AUTO ISO** sub-menus have no influence, i.e. the full shutter speed range of the camera is available.
- Depending on the initial exposure setting, the working range for automatic bracketing may be limited.
- Regardless of this, the specified numbers of pictures are always taken, which may mean that at the end of the working range, several pictures in a series have the same exposure.
- The function remains active until it is deactivated again in the menu or the camera is switched off.

Values above and below the metering range

If the values are below the metering range of the camera, exact exposure metering is not possible. The metered values that may then be displayed in the viewfinder can result in incorrect exposure results.

For this reason the display **Lf** always appears in the viewfinder if the values are below the metering range.

Note:

If the values are above and below the metering range, the time or aperture value in the top panel display flashes.

Notes:

- The longest possible exposure time depends on the set sensitivity: ISO100 -125s / ISO200 -60s / ISO400 -32s / ISO800 -16s / ISO1600 -8s / ISO3200 -4s / ISO6400 -2s / ISO12500 -1s
- Long exposure times can be associated with picture noise. To reduce this annoying phenomenon, the Leica S automatically takes a second “black picture” (taken with the shutter closed) after pictures with slow shutter speeds. The noise present in this parallel picture is then digitally “subtracted” from the data for the real picture.
- This doubling of the “exposure” time can be significant at longer exposure times, and must be allowed for. During this time the camera should not be turned off.
- When taking pictures with long exposures we recommend that the eyepiece cover supplied is fitted. This prevents any undesirable additional exposure.
- With shutter speeds slower than 1/2s, the message **Noise Reduction** appears in the monitor.
- Pictures taken with long exposures with the B setting are taken only with the camera's internal focal plane shutter even if the main switch is set to **CS**.

Taking photographs with the self-timer

You can use the self-timer of the Leica S to take a picture with a delay of either 2 or 12 s.

Setting / performing the function

1. In the menu, under **CAMERA**, select the item **Drive Mode** and
2. select the required delay time in the sub-menu
3. To start the process, press the shutter button (see also "Shutter button")

Note:

During the delay time, the delay time can be restarted, i.e. prolonged, by pressing the shutter button again.

Procedure

With 2 s delay time:

Exposure metering is performed first, in autofocus mode the focus is adjusted and the mirror is folded up. Only then does the delay time start.

With 12 s delay time:

The delay time starts immediately after the shutter button is pressed, the mirror is folded up 2 s before the picture is taken.

Displays

The running delay time is displayed:

- In the monitor by the display **Capture in 12s** and the countdown of the remaining time until the picture is taken.
- By the LED on the front of the camera – for the first 10 s with 12 s delay time – first flashing slowly, then flashing fast.