

NORMARC 7011

INSTRUMENT LANDING SYSTEM

GENERAL DESCRIPTION





TABLE OF CONTENTS

DESCRIPTION OF NORMARC 7011 1-FREQUENCY LOCALIZER SYSTEM.1

1	GENERAL DESCRIPTION	1
1.1	Technical Specification.....	1
1.1.1	Signal Minimum Performance LLZ	1
1.1.2	Environmental Characteristics	2
1.1.3	EMC Characteristics	2
1.1.4	Mechanical Characteristics	2
1.1.5	Power Supply.....	3
1.2	General Information.....	3
1.2.1	Introduction	3
1.2.2	Product Type Numbers.....	6
1.2.3	Abbreviations	7
2	PHYSICAL ORGANIZATION.....	8
2.1	Module and Assembly Location	8
2.2	Power Supply	8
3	SYSTEM DESCRIPTION.....	12
3.1	Overview	12
3.2	Physical Description	12
3.3	Monitors.....	13
3.4	Transmitters / Modulators.....	13
3.5	TX Control	13
3.6	Remote Monitoring (RMS) Unit	14
3.7	Remote Control Unit.....	14
3.8	Remote Slave Panel.....	14
3.9	Remote Maintenance Monitoring (RMM)	14
3.9.1	RMM Access.....	16
3.9.2	Local Keyboard/Display Functions	16
3.9.3	Diagnostic functions.....	17
4	ELECTRICAL INSTALLATION	18
4.1	Connection Overview	18
4.2	Power and Battery.....	18
4.3	RF Inputs.....	19
4.4	RF Outputs	20
4.5	DC Loop	21
4.6	Remote Control	22
4.7	PC and Modem	23
4.8	DME	24
4.9	Analog Inputs	25
4.10	Digital Inputs and Outputs.....	26
4.11	Battery Warning.....	27
4.12	Remote control connections.....	28
4.13	Remote slave connection	30
4.14	Interlock switch connection	31

LIST OF FIGURES

Figure1-1	Typical ILS installation	3
Figure1-2	Localizer block diagram	4
Figure1-3	Localizer Antenna	5
Figure1-4	Localizer Cabinet Installation	5
Figure1-5	Localizer Cabinet External Label	6
Figure2-1	NM 7011 Module Location - Front view.	9
Figure2-2	NM 7011 Module Location - Rear view of main section.	10
Figure2-3	NM 7011 Module Location - Front view of wall-mounted section	11
Figure3-1	ILS block diagram.	12
Figure3-2	The NM 7000 series RMM/RMS systems.	15
Figure3-3	Local Control Panel	17
Figure4-1	ILS main cabinet connection overview.	18
Figure4-2	Power and backup battery connections.	19
Figure4-3	RF input connections.	19
Figure4-4	RF output connections.	20
Figure4-5	DC loop connections.	21
Figure4-6	Remote control connection.	22
Figure4-7	PC and modem connections.	23
Figure4-8	DME connections.	24
Figure4-9	Analog input connections.	25
Figure4-10	Digital input/output connections.	26
Figure4-11	Battery warning connections.	27
Figure4-12	Remote control to ILS connection	28
Figure4-13	Remote control power supply connections	29
Figure4-14	Remote slave connection	30
Figure4-15	Interlock switch connection	31

LIST OF TABLES

DESCRIPTION OF NORMARC 7011 1-FREQUENCY LOCALIZER SYSTEM

1 General Description

1.1 Technical Specification

NM 7011 Single-Frequency Localizer Cabinet.

1.1.1 Signal Minimum Performance *LLZ*

Transmitter

Frequency range	108-112 MHz
Frequency tolerance	$\pm 0.002\%$
Output power (CSB)	5-15 W adjustable
Harmonic radiation	2.5 uW maximum
Spurious	25 uW maximum
Output power stability	± 0.2 dB
CSB/SBO stability	± 0.3 dB / $\pm 5^\circ$

Modulator

Modulation depth 90/150 Hz	20%
adjustable range	10-25%
SDM stability	$\pm 0.3\%$ SDM
DDM stability	$\pm 0.1\%$ DDM
Frequency tolerance	± 0.05 Hz
Total harmonic dist. (90/150 Hz)	1% maximum
Phase locking (90 Hz to 150 Hz)	5° maximum ref 150 Hz
SBO phaser adjustment range	$\pm 10^\circ$

Identity Keyer

Modulation frequency	1020 Hz ± 10 Hz
Modulation depth	5-15% adjustable
Distortion	6% Maximum
Speed of identification	7 Words/Min. approx.

Monitoring

Alarm Functions	Range (*)
RF power reduction	1-5 dB
Change of nominal CL	$\pm 4-25$ uA
Change of nominal DS from nominal value	$\pm 10-50$ uA
Change of nominal NF	$\pm 4-25$ uA
Change of nominal SDM	$\pm 2-6\%$ SDM
Total period of radiation out of tolerance	1-10 sec.
Additional NF time delay	0-20 sec.
Line break, ILS - Remote Control (disable optional)	

Identification lost or continuous
(optional)

Monitor input levels:

Adjustment range, nominal level	-5 to -34 dBm
AGC range for less than 1% change in SDM	5 dB

Monitor stability at nominal levels:

RF power values	$\pm 0,2$ dB
DDM values	± 1 μ A
SDM values	$\pm 0,5\%$ SDM

Warning Functions:

RF power reduction	40-75% of Alarm limit
Change of nominal CL	40-75% of Alarm limit
Change of nominal DS	40-75% of Alarm limit
Change of nominal NF	40-75% of Alarm limit
Change of SDM	40-75% of Alarm limit
Mains failure	

Remote Control

Data Transmission Medium	2-wire line, 600 ohm
Data modulation	serial, FSK
Transmitter level	-10dBm ± 2 dB
Receiver dynamic range	-10dBm to -34dBm

* asymmetrical limits are possible.

1.1.2 Environmental Characteristics

Operating temperature	-10 to +55 °C
Storage temperature	-30 to +60 °C

1.1.3 EMC Characteristics

EMR:	EN 55022 class B
Spurious and harmonics:	CISPR 22

1.1.4 Mechanical Characteristics

Dimensions: (H x W x D)

ILS Rack:	1020x600x500 mm
Remote control:	129x71x170 mm
Slave panels:	129x41x170 mm

Weight: 85 kg – 95 kg depending on model

The ILS rack is wall mounted. The remote control and slave panels fit a standard 3U (132mm) high 19" subrack.

1.1.5 Power Supply

External supply:

Input voltage:	230V +15%/-20%, 45-65 Hz or 120V +15%/-20%, 45-65 Hz
Output voltage:	27,6V
Output current:	20A max

ILS cabinet

Input voltage	22-28V DC
Current consumption:	8A – 14A depending on configuration
Stand-by Battery	24V DC nominal, 85 Ah-110Ah valve regulated lead-acid battery recommended

1.2 General Information

This paragraph gives a description of a typical ILS installation and the Normarc Localizer system. Conventions and abbreviations used in this manual are also given.

1.2.1 Introduction

This is an overview of Normarc's NM701X ILS localizer systems

1.2.1.1 ILS Overview

A complete Instrument Landing System comprises:

- A LOCALIZER SYSTEM, producing a radio course to furnish lateral guidance to the airport runway.
- A GLIDE PATH SYSTEM, producing a radio course to furnish vertical guidance down the correct descent angle to the runway.
- MARKER BEACONS, to provide accurate radio fixes along the approach course.

The layout of a typical ILS airport installation is shown below.

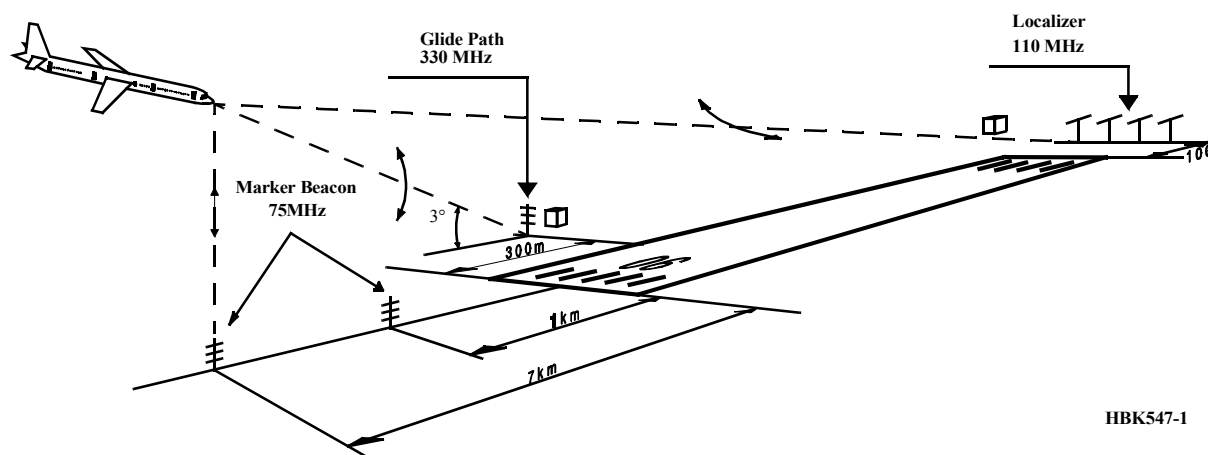

Figure 1-1 Typical ILS installation

1.2.1.2 Localizer Overview

The complete ILS Localizer system comprises:

- A LLZ transmitter/monitor cabinet

- An antenna distribution network
- A monitor network
- A LLZ antenna array
- Near-field monitor antenna

A block diagram is shown below:

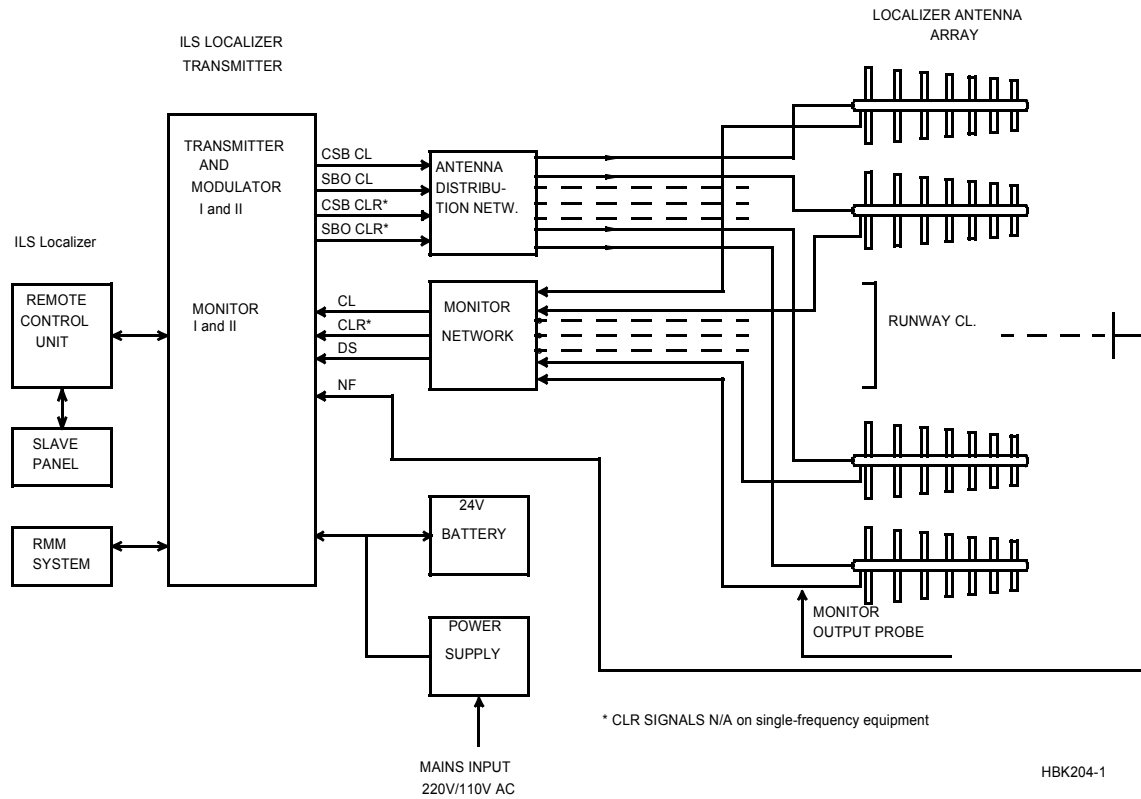

Figure 1-2 Localizer block diagram



Figure1-3 Localizer Antenna



Figure1-4 Localizer Cabinet Installation

1.2.1.3 Localizer Description

The antenna array of the ILS localizer transmitter is located on the extension of the centerline of the instrument runway of an airfield, but is located far enough from the stop end of the runway to prevent it being a collision hazard. The localizer antenna radiates a field pattern directed along the centerline of the runway towards the middle and outer markers. The antenna also furnish information outside the front course area in the form of full fly-left or full fly-right indications (CLEARANCE).

All localizer installations transmit a STATION IDENTIFICATION in morse code at periodic intervals. This is a 1020 Hz tone that is keyed to form the basic station identifier.

The localizer is designed to provide a signal at a minimum distance of 25 miles within +/- 10 degrees, and at a minimum distance of 17 nautical miles between +/- 10 and +/- 35 degrees from the front course line. (Refer to ICAO Annex 10 Chapter 3.1.3.3.1)

1.2.2 Product Type Numbers

The Normarc product numbering system is based on the following three levels:

- System
- Assembly
- Module

Systems have type numbers starting with NM, for example NM 7033. Systems consist of assemblies, modules and parts.

Assemblies have type numbers consisting of three letters, a three- or four- digit number and a letter, for example LPA 1230A. LPA is an abbreviation of Localizer Power amplifier Assembly, 1230 is a running number, and the last letter is the variant designator. Assemblies can consist of assemblies, modules and parts.

Modules have type numbers consisting of two letters, a three- or four- digit number and a letter, for example FD 1235A. FD is an abbreviation of Feedback Detector, 1235 is a running number, and the last letter is the variant designator. Modules consist of parts.



Figure 1-5 Localizer Cabinet External Label

1.2.3 Abbreviations

AC	Alternating Current
ADC	Analog to Digital Converter
AGC	Automatic Gain Control
CL	Course Line
CLR	Clearance
COU	Course
CPU	Central Processing Unit
CS	Course Sector
DAC	Digital to Analog Converter
DC	Direct Current
DDM	Difference in Depth of Modulation
DF	Difference Frequency
DL	Dc Loop
DS	Displacement Sensitivity
DSP	Digital Signal Processor
EEPROM	Electrically Erasable Programmable Read Only Memory
EMC	ElectroMagnetic Compatibility
EMI	ElectroMagnetic Interference
EPROM	Erasable Programmable Read Only Memory
FFT	Fast Fourier Transform
FIFO	First-In-First-Out
FPGA	Field Programmable Gate Array
GPA	Glidepath Power amplifier Assembly
I/F	InterFace
I ² C	Inter Integrated Circuit
IIC	Same as I ² C
ILS	Instrument Landing System
LED	Light Emitting Diode
LF	Low Frequency
LLZ	Localizer
LPA	Localizer Power amplifier Assembly
LRU	Line Replacable Unit
MCU	Monitor Combiner Unit
NAV	NAVigation signals
NF	Near Field
PC	Personal Computer
RAM	Random Access Memory
RF	Radio Frequency
RMM	Remote Maintenance Monitor
RMS	Remote Monitoring System
ROM	Read Only Memory
RTC	Real Time Clock
SC	Station Control
SDM	Sum in Depth of Modulation
SPA	Same Parameter Alarm
SRAM	Static Random Access Memory
STB	Standby
SW	SoftWare
TRM	TeRMinator
TX	Transmitter

2 Physical Organization

2.1 Module and Assembly Location

The figures on the following pages show the locations of the modules in the main cabinet.

Figure 2-1 shows the main section of the LLZ cabinet from a front view, with indications of the plug-in board locations.

Figure 2-2 shows the same section from a rear view, while Figure 2-3 shows the top half of the wall-mounted section.

In addition, the Remote Control Assembly RCA1240C/D and Remote Slave SF 1344A are installed in the technical control room and the control tower, respectively.

2.2 Power Supply

An External Power Supply, operating at 230V/120V mains input and providing 27V at 20A, is normally supplied with the equipment. In special cases, a second external power supply is supplied.

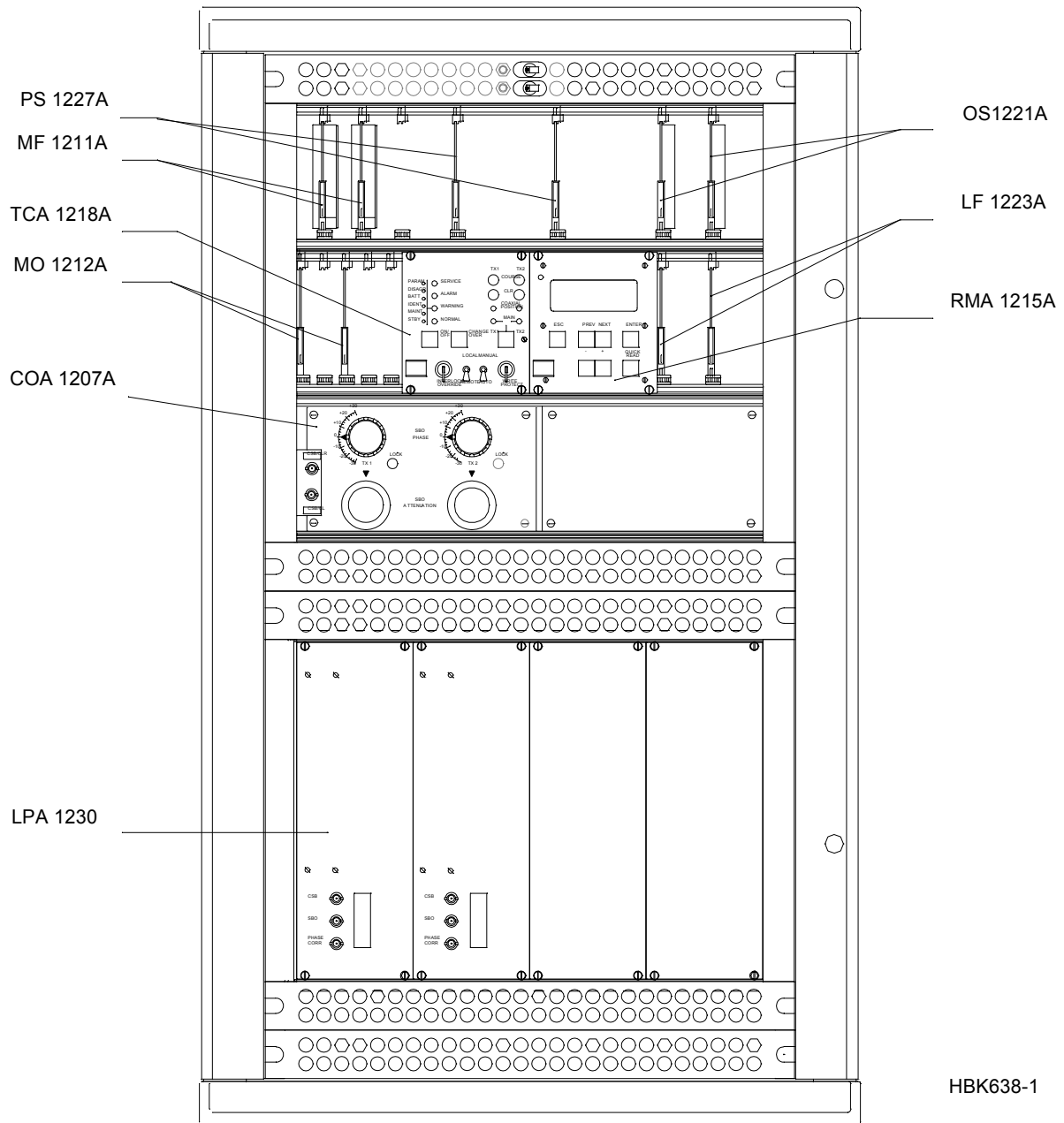

Figure2-1 NM 7011 Module Location - Front view.

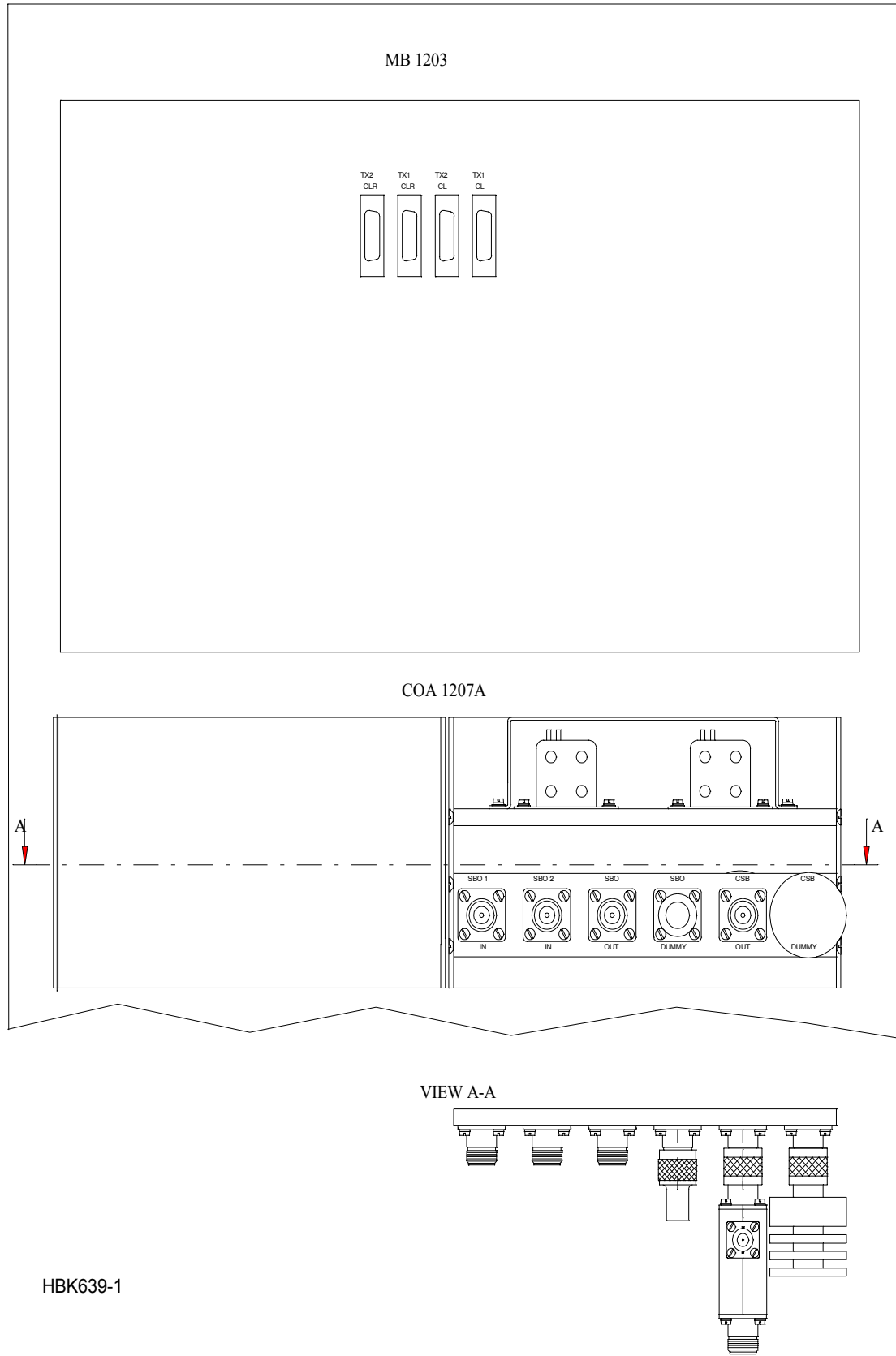

Figure2-2 NM 7011 Module Location - Rear view of main section.

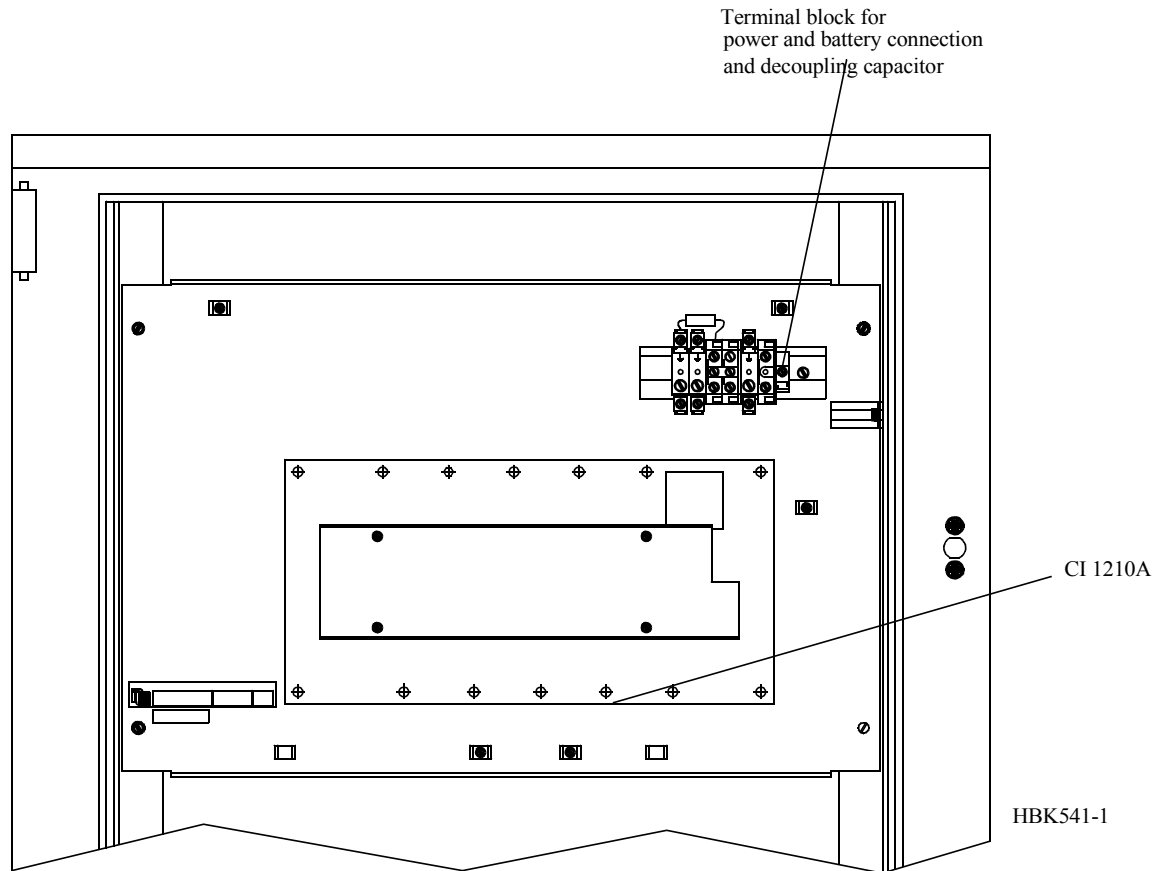

Figure2-3 NM 7011 Module Location - Front view of wall-mounted section

3 System description

This chapter gives a functional overview of the NM70xx ILS systems.

3.1 Overview

The complete ILS electronic system is housed in a compact, wall mounted cabinet. The cabinet and the electronics, except for RF units, are common to the LLZ and GP systems

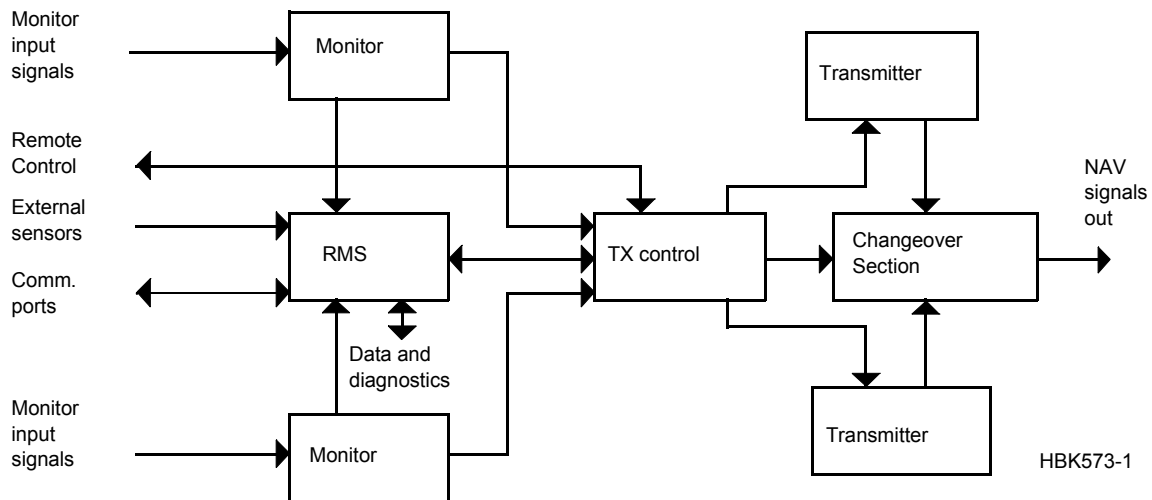

Figure3-1 ILS block diagram.

The ILS cabinets can be configured for Cat I, Cat II, or Cat III requirements with no basic changes.

Eight models are available:

NM 7011	Single frequency LLZ
NM 7012	Single frequency LLZ with hot standby monitoring (Cat III)
NM 7013	Two frequency LLZ
NM 7014	Two frequency LLZ with hot standby monitoring (Cat III)
NM 7031	Single frequency GP
NM 7032	Single frequency GP with hot standby monitoring (Cat III)
NM 7033	Two frequency GP
NM 7034	Two frequency GP with hot standby monitoring (Cat III)

The system is based on modern technology with extensive Remote Monitoring and Maintenance capabilities, and very high reliability and integrity. To meet this objective, the monitor comparator and station control are based on digital hardware, while the RMS interface is microprocessor based.

3.2 Physical Description

The cabinet contains three sections:

- The electronics card cage
- The change-over section
- The transmitter / PA section

The electronics card cage contains the RF oscillators, the LF signal generators, the monitors,

the station control, the RMS processor, and the voltage regulators.

The change-over section contains coaxial relays, attenuators and phasers for the RF outputs.

The transmitter / PA section contains the PA blocks including couplers etc. for each output.

The cabinet is divided in two parts, with the rear part fixed to a wall, and the front part hinged to give access to interior of the cabinet.

All external connections are made to the rear part of the cabinet.

3.3 Monitors

The ILS has duplicated monitors with inputs for Course Line (CL), Displacement Sensitivity (DS), Near Field (NF), and Clearance (CLR) (Dual Freq. only). The signals are detected by the input stage, and then digitized. In the next block they are filtered by a Fast Fourier Transform performed by a signal processor. The results for each parameter is then compared with stored limits in a digital hardware comparator.

Each of the two monitors consists of two modules. For Cat III use, Hot Standby monitoring can be added by using one additional monitor and associated RF couplers and combiners.

The design of the monitors ensures a very high integrity due to the use of digital hardware for the alarm comparators and a very simple Fast Fourier filtering with a signal processor. In addition, the monitor is checked by automatic self-tests.

The alarm limits are stored locally in EEPROM, and can be updated from the RMS processor, with a separate hardware write protection to ensure that the integrity is not affected by the RMS system.

3.4 Transmitters / Modulators

The transmitters are duplicated, either single frequency or dual frequency. Each transmitter consists of a RF oscillator, a LF generator, and one or two PA blocks (single or dual frequency).

The RF oscillator uses a synthesizer for easy frequency changes and simple logistics. The oscillator has two outputs for use in dual frequency systems.

The LF generator contains the generators for 90Hz, 150Hz and 1020Hz signals, the ident keyer / sequencer and interface for DME master or slave keying. All signals are generated by division from a common clock oscillator, ensuring very stable phase relations between the modulation signals.

The modulation balance, modulation sum, RF level and Ident morse code are set in this module by means of multiplying digital to analog converters. The values are stored locally in EPROM and can be updated from the RMS processor with hardware write protection.

The same LF generator is used for single and dual frequency systems.

3.5 TX Control

The TX control unit controls the system dependent on alarms from the monitors and inputs

from the local control, the remote control and, optionally, the RMS system. It also generate status information to the same units. The local control and status indicators are a part of the TX Control unit.

All functions in the TX Control are based on digital hardware to ensure the highest integrity.

3.6 Remote Monitoring (RMS) Unit

The RMS unit contains the system microprocessor. It handles storage and read-out of monitor parameters, measurements for maintenance and fault finding, and performs fault analysis to isolate faults to line replaceable modules. It is also used to set monitor limits and transmitter adjustments.

The RMM handles communication to local and remote RMS computers, and in addition it handles a small display and keyboard for parameter setting and readout.

3.7 Remote Control Unit

The remote control unit is used in the tower or in the technical control room. It has indicators for operating status as well as detailed warnings and an aural alarm device with reset. It can control equipment on/off and change-over, and has an Access Grant-switch to allow remote control from the RMS system.

The Remote Control Unit is connected to the ILS by one telephone pair cable.

3.8 Remote Slave Panel

The slave panel is connected to the remote control by a multipair wire. It is intended for use in the control tower. It has indicators for normal / warning / alarm and has an aural alarm device. in addition it can turn the equipment on and off, and has an aural alarm reset.

Optionally a slave panel with remote control functionality can be delivered.

3.9 Remote Maintenance Monitoring (RMM)

The NM7000 series has a built-in Remote Maintenance Monitoring system. This system consists of the RMS system, remote PC terminals with the RMM program installed, and the local keyboard/display. Figure 3-2 illustrates the RMM/RMS systems

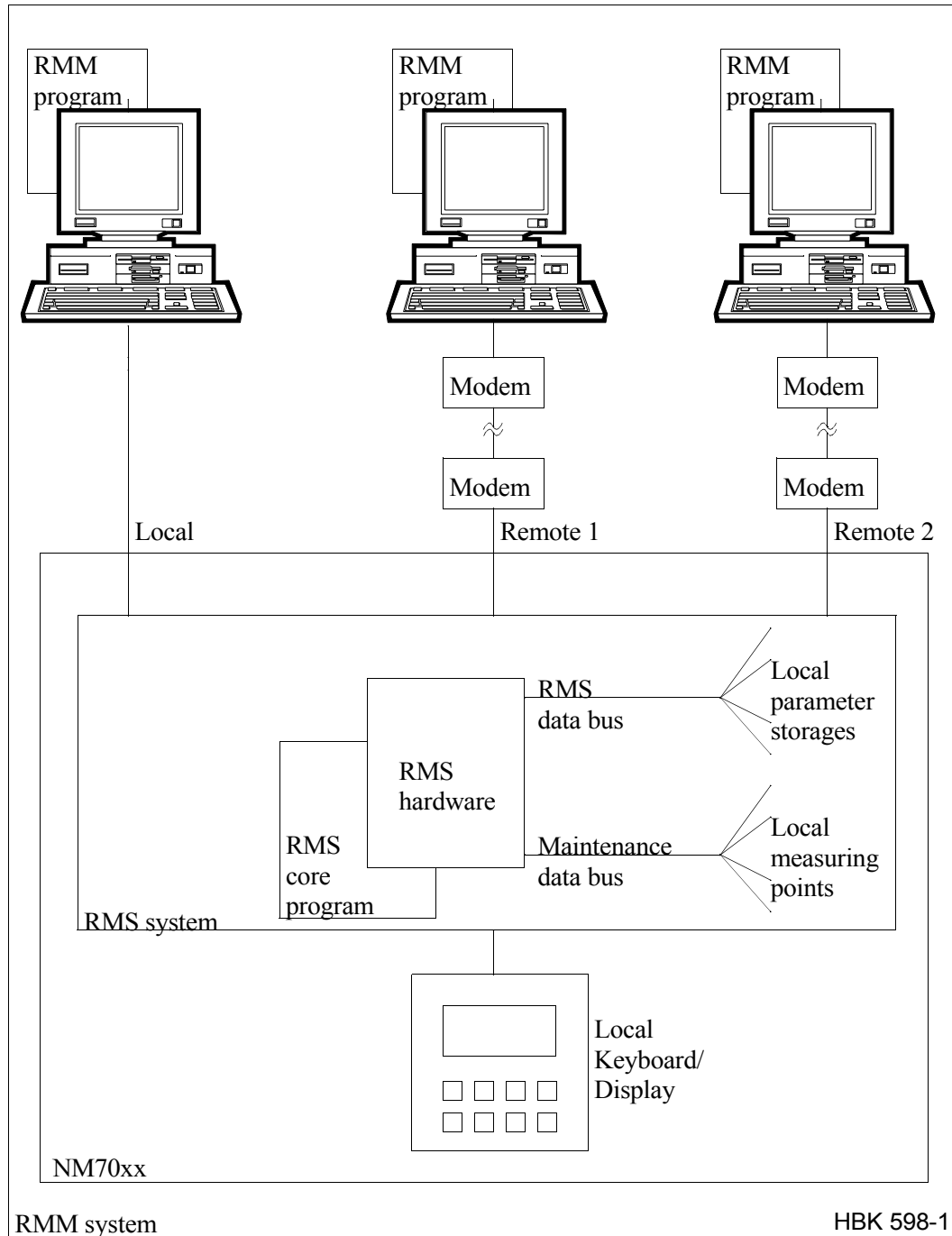

Figure3-2 The NM 7000 series RMM/RMS systems.

The centre of the RMS system is a CPU with the RMS core program. The RMS collects measurements and diagnostic data, and makes them available to the user. The collected information allows easy and cost effective maintenance, fault finding and routine reporting. In addition, system settings are distributed and parameter readings are collected via the RMS/ CPU.

External personal computers are used for a user-friendly interface to the RMM system. The equipment has three serial output ports, typically used to connect a local PC, a PC in the airport technical equipment room, and a modem for connection to a central maintenance facility.

The local keyboard/display allow readings and control through an LCD display and a seven-button keypad. This gives access to the RMM functionality without the need for a PC.

3.9.1 RMM Access

Access to the RMM system is controlled by multiple hardware and software access controls. One password is required for each access level, i.e. one password for level 1, two for level 2 and three for level 3. Optional hardware controls may inhibit writing in the upper access levels.

Access level 1

- Readout of all the monitor values, warning and alarm limits.
- Readout of all the maintenance values and warning limits.
- Readout of all the delays.
- Readout of all the monitor DDM offsets.

Access level 2

- TX1 and TX2: 90/150 Hz on/off.
- TX1 and TX2: morse normal, continuous, TST or off.
- TX1 and TX2: test-signal 90 Hz or 150 Hz dominance on/off.
- Diagnostics.

Access level 3

- Settings of all the monitor warning and alarm limits.
- Settings of all the maintenance warning limits.
- Settings of all the delays.
- Settings of all the monitor DDM offsets.

3.9.2 Local Keyboard/Display Functions

Through a menu-based interface all main commands, adjustments and monitor limits are accessible from the front panel keypad and LCD display. In addition a quick-read function gives read-out of all main monitor parameters in a glance.

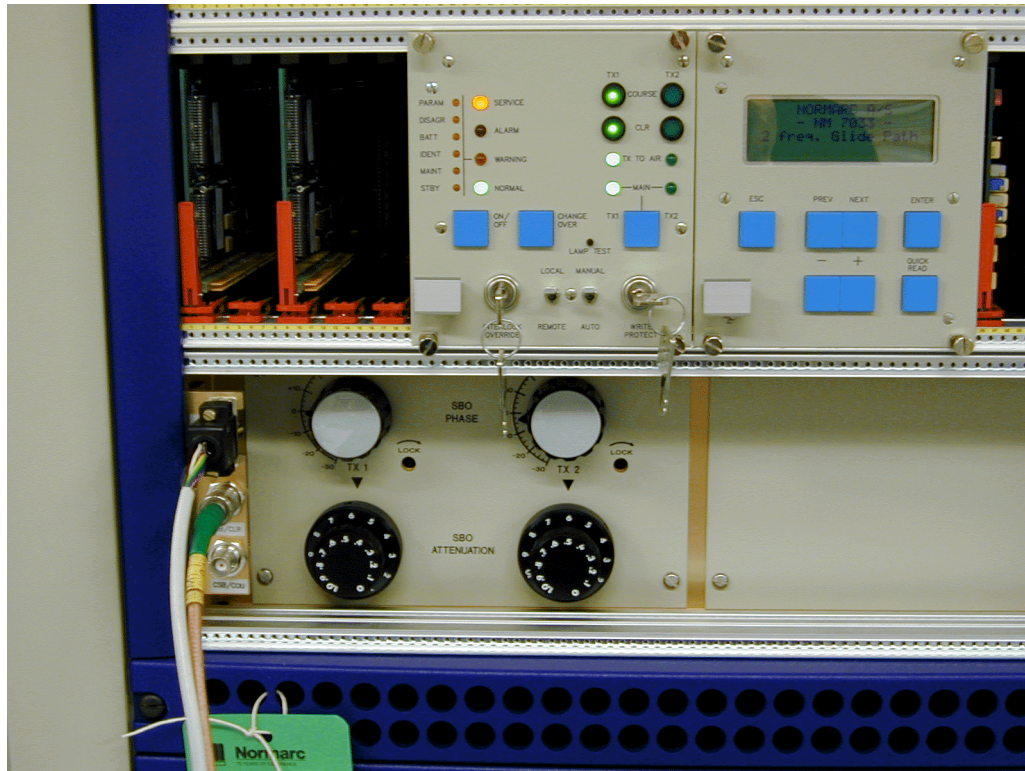

Figure 3-3 Local Control Panel

3.9.3 Diagnostic functions

The system contains internal measuring points and diagnostic functions to isolate faults to failed modules. The values measured are referred to as *maintenance parameters*. Please refer to the NM70xx Operating Manual.

4 Electrical Installation

This paragraph describes the external electrical connections of the NM 7011 main cabinet.

4.1 Connection Overview

The ILS main cabinet consists of three connector sites, illustrated in Figure 4-1

- The ILS RF signals to and from the antenna system are connected at the top of the main cabinet. These connectors may be moved to the bottom, see *Mechanical Installation*.
- The power supply (supplies) and the backup battery are connected to the power connector rail inside the cabinet back section.
- All other external connections are sited on the Connection Interface board CI1210A inside the cabinet back section.

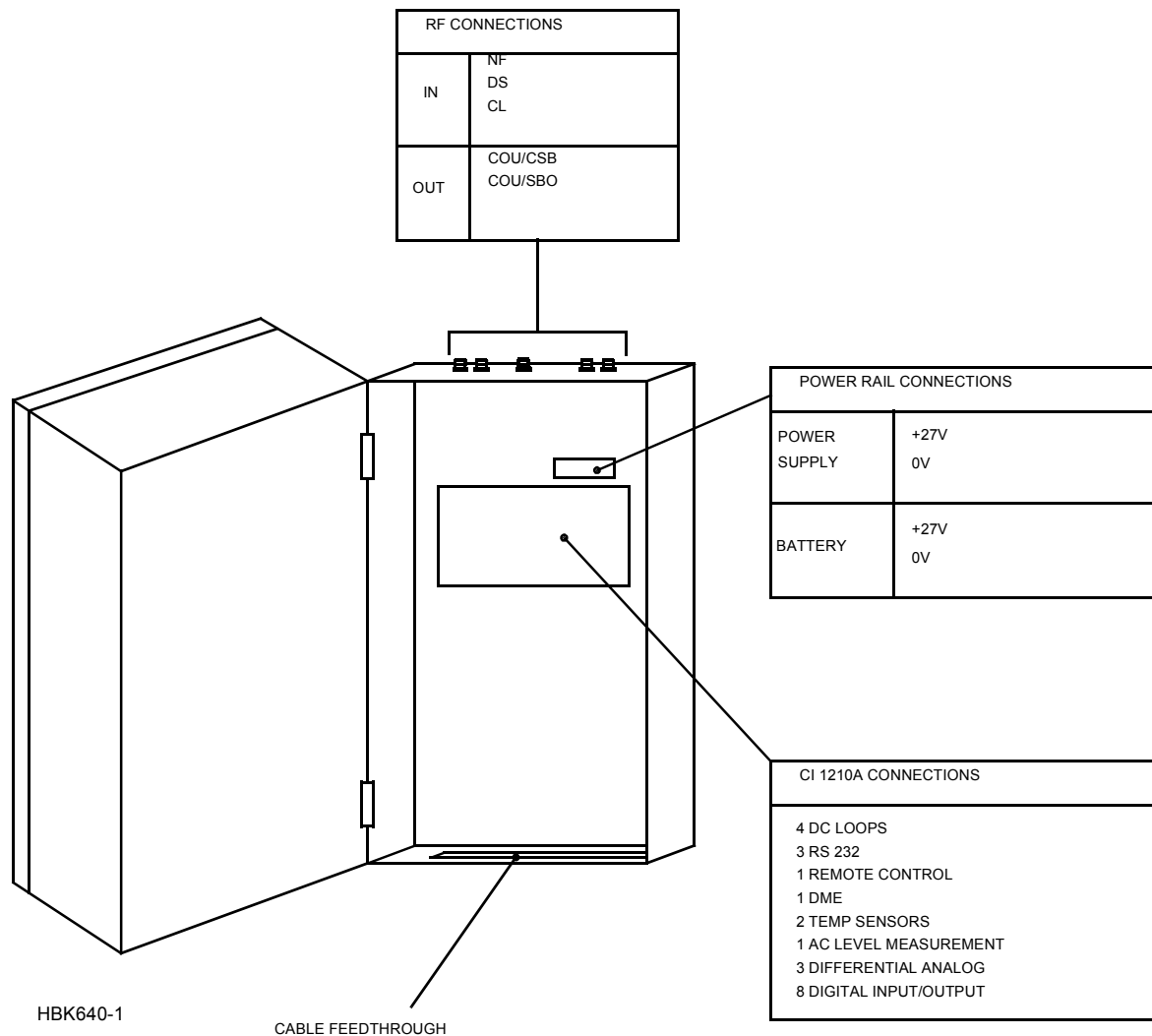

Figure4-1 ILS main cabinet connection overview.

4.2 Power and Battery

The power supply and the backup battery are connected to the power connector rail inside the cabinet back section as shown in Figure 4-2. If two power supplies are used, these are paral-

lel coupled outside the cabinet. The cables used should have 4mm² intersection.

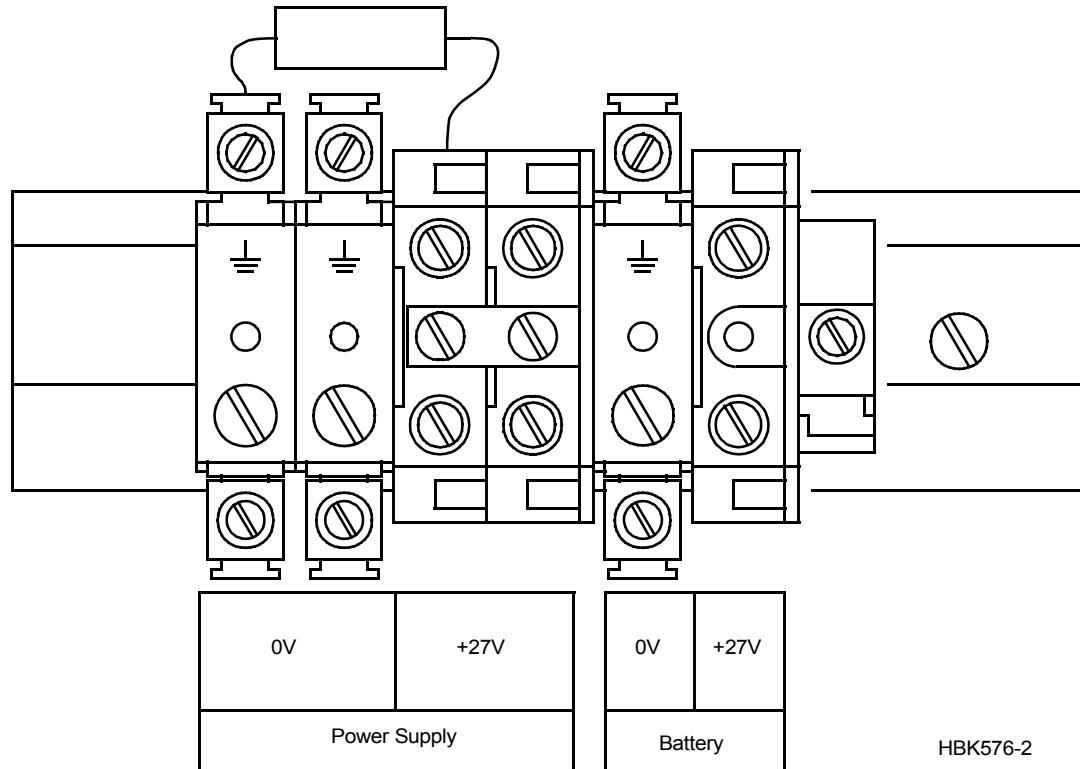

Figure4-2 Power and backup battery connections.

A DC powered modem or other external equipment designed for 22V - 27V DC can be connected to the fused terminal block marked Modem. Maximum current consumption should be 1 A.

4.3 RF Inputs

The RF inputs are:

- Course Line - CL.
- Near Field Antenna - NF.
- Displacement Sensitivity - DS.

These are connected as shown in Figure 4-3 (front view).

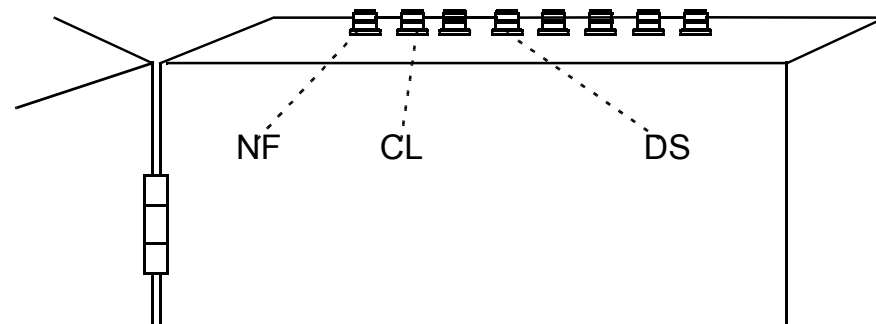

HBK641-2

Figure4-3 RF input connections.

4.4 RF Outputs

The RF outputs are sited at the cabinet top as illustrated in Figure 4-4. The connections are:

All applications:

- COU SBO - COUrse Tx SideBand Only.
- COU CSB - COUrse Tx Carrier and SideBand.

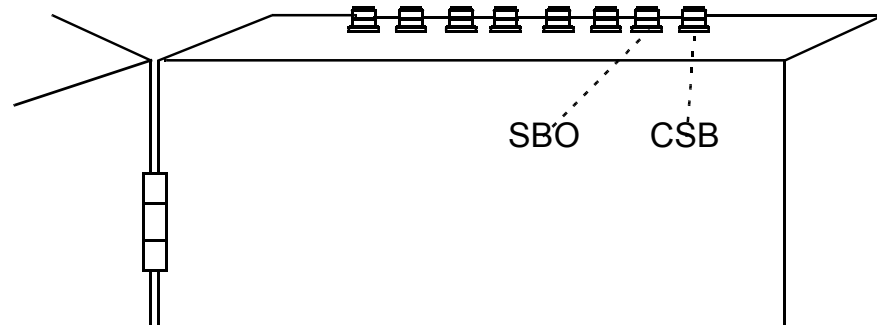

HBK642-2

Figure4-4 RF output connections.

4.5 DC Loop

The DC loops are connected to the Connection Interface board CI1210A in the cabinet back section. Location and pin out are illustrated in Figure 4-5

- *DL_REF** are the reference voltages from the main cabinet.
- *DL_DETECT** are the return voltages from the antennas.
- *GND* is main cabinet ground.

Suitable female connectors are Weidmüller *BLZ-5.08/6* or equivalent.

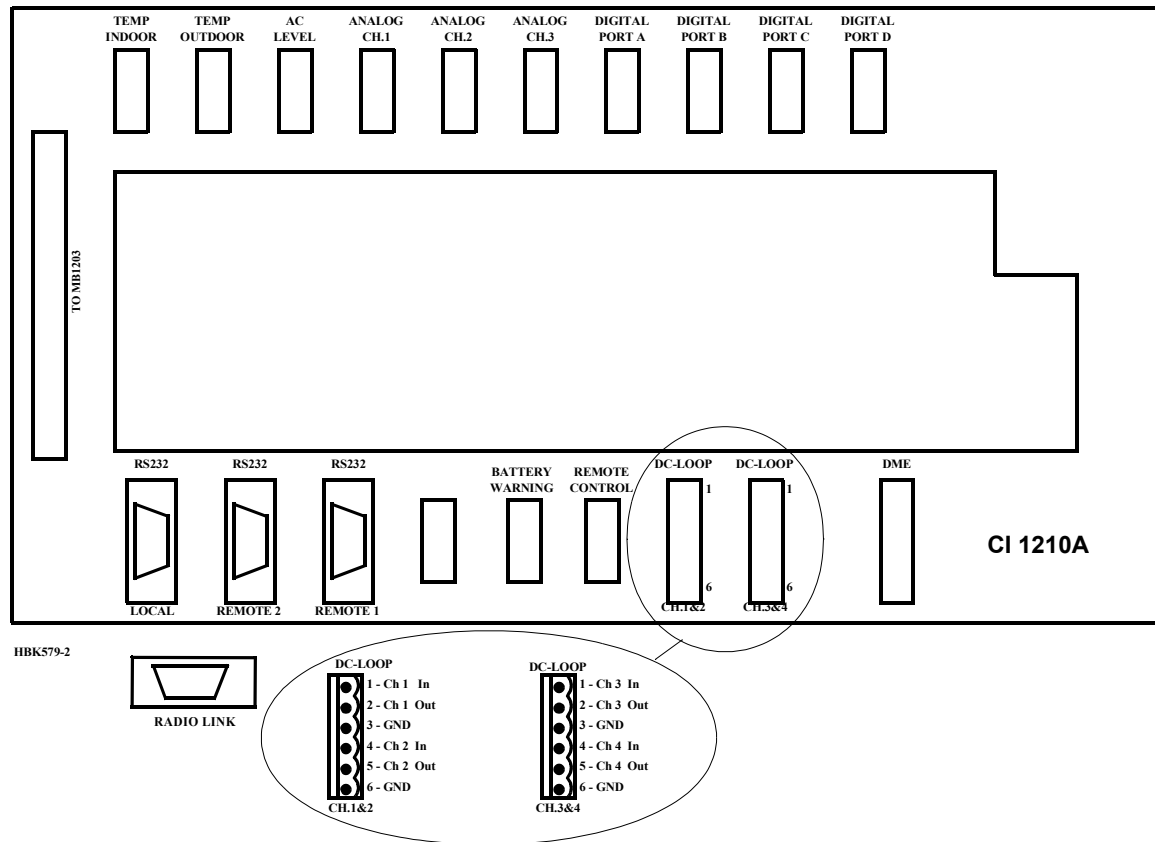

Figure4-5 DC loop connections.

4.6 Remote Control

The remote control is connected to the Connection Interface board CI1210A as illustrated in Figure 4-6. The connection of the remote control, remote slave panel and interlock switch is done at the remote control site and covered in chapter 4.12 - 4.14

- *FSK_[P,N]* is the modem line pair.
- *GND* is main cabinet ground.

For normal FSK modem operation the straps S9-11 on CI1210A should be mounted.

A suitable female connector is Weidmüller *BLZ-5.08/4* or equivalent.

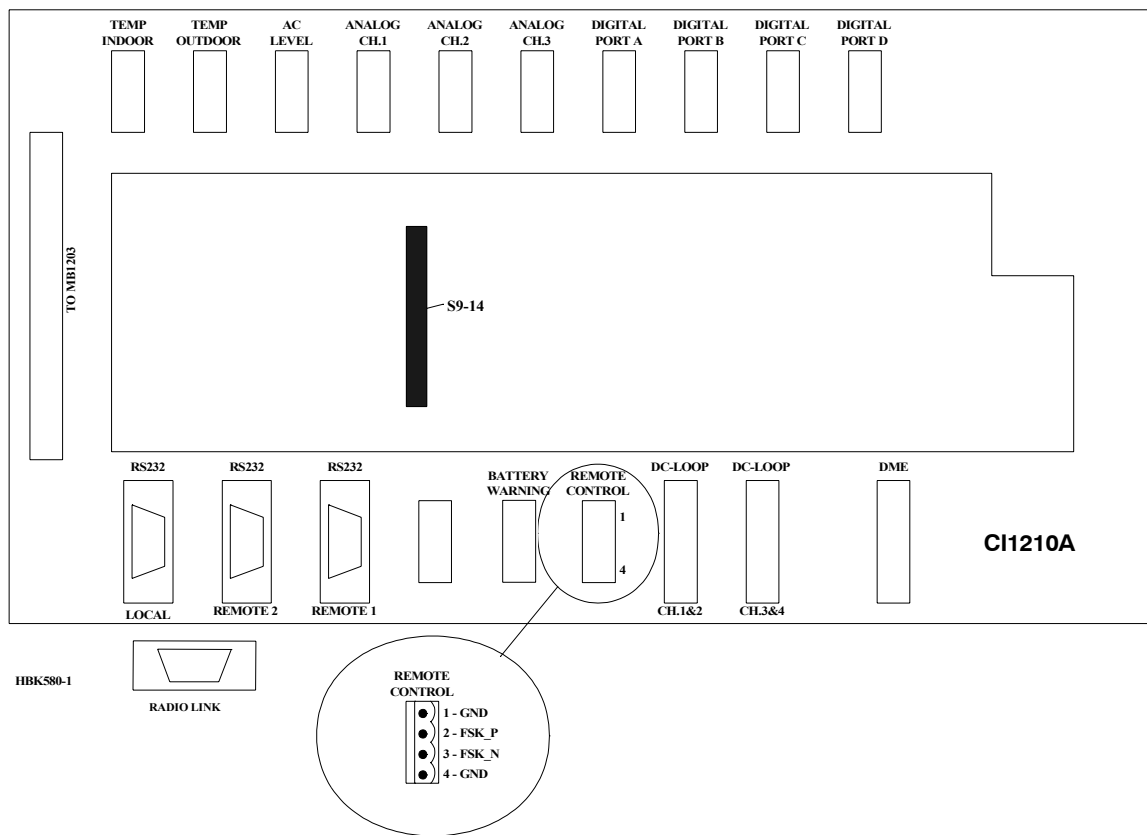

Figure4-6 Remote control connection.

4.7 PC and Modem

PC terminals and modems are connected to the standard pin out RS232, 9 pins DSUB connectors on the Connection Interface board CI1210A as illustrated in Figure 4-7

Recommended connections are:

- LOCAL - the PC located at the ILS main cabinet site.
- REMOTE 1 - the PC located at the airport technical maintenance site.
- REMOTE 2 - distant PC terminals connected through a modem.

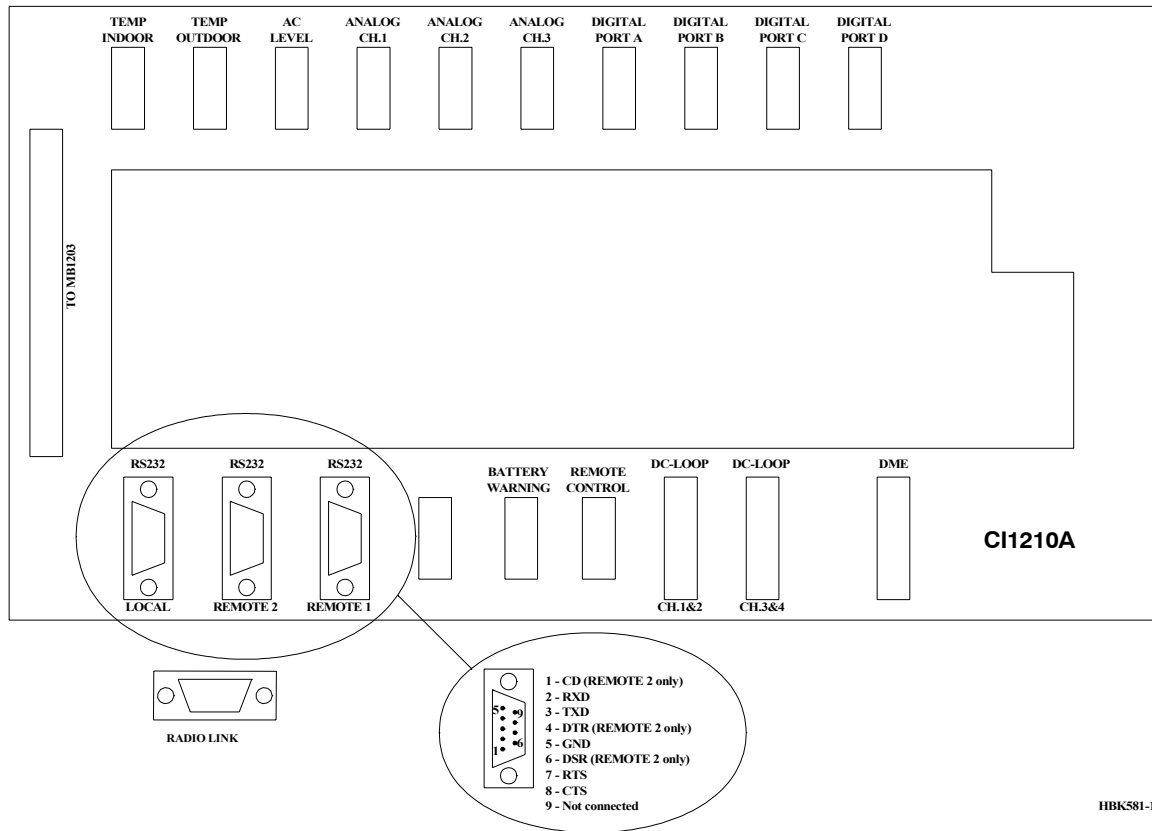

HBK581-1

Figure4-7 PC and modem connections.

4.8 DME

Distance Measurement Equipment DME is connected to the Connection Interface board CI1210A as illustrated in Figure 4-8

- *ACT_DME[P,N]* is the positive and negative terminal of the DME active signal from the DME, respectively.
- *IN_DME[P,N]* is the positive and negative terminal of the morse code envelope signal from the DME, respectively.
- *OUT_DME[P,N]* is the positive and negative terminal of the morse code envelope signal to the DME, respectively.

A suitable female connector is Weidmüller *BLZ-5.08/6* or equivalent.

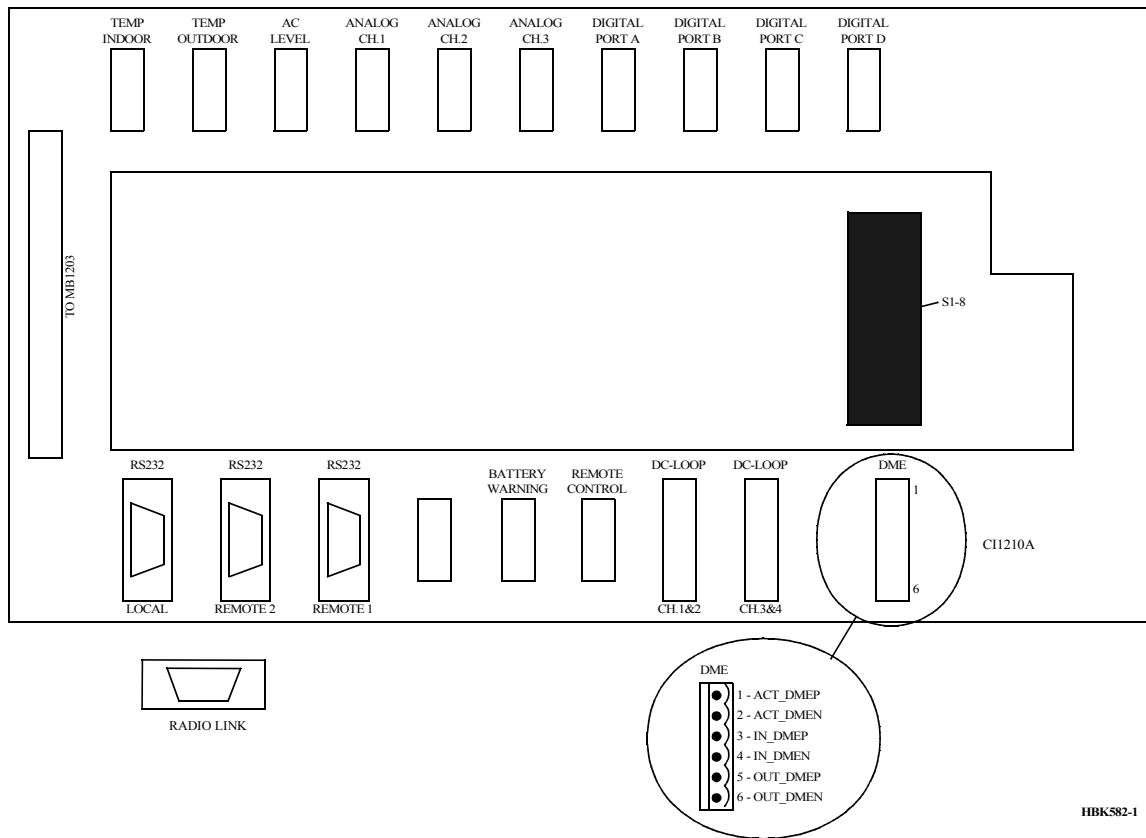

HBK582-1

Figure4-8 DME connections.

4.9 Analog Inputs

The analog inputs are connected to the Connection Interface board CI1210A as illustrated in Figure 4-9

The inputs are:

- ANALOG CH.1-3 - three differential DC analog inputs, P is the positive and N is the negative terminal.
Maximum voltage: ±15V
Input impedance: 10kohms.
- TINDOOR, TOUTDOOR - temperature measurement inputs with interface to an LM35 temperature sensor.
Maximum voltage: ±15V.
Input impedance: 10kohms.
- AC LEVEL - AC level measurement input. Intended for use with a battery eliminator (i.e. 220/9VAC) to monitor the mains voltage.
Maximum voltage: 24Vpp.
Input impedance: 10kohms.

Suitable female connectors are Weidemüller *BLZ-5.08/4* or equivalent.

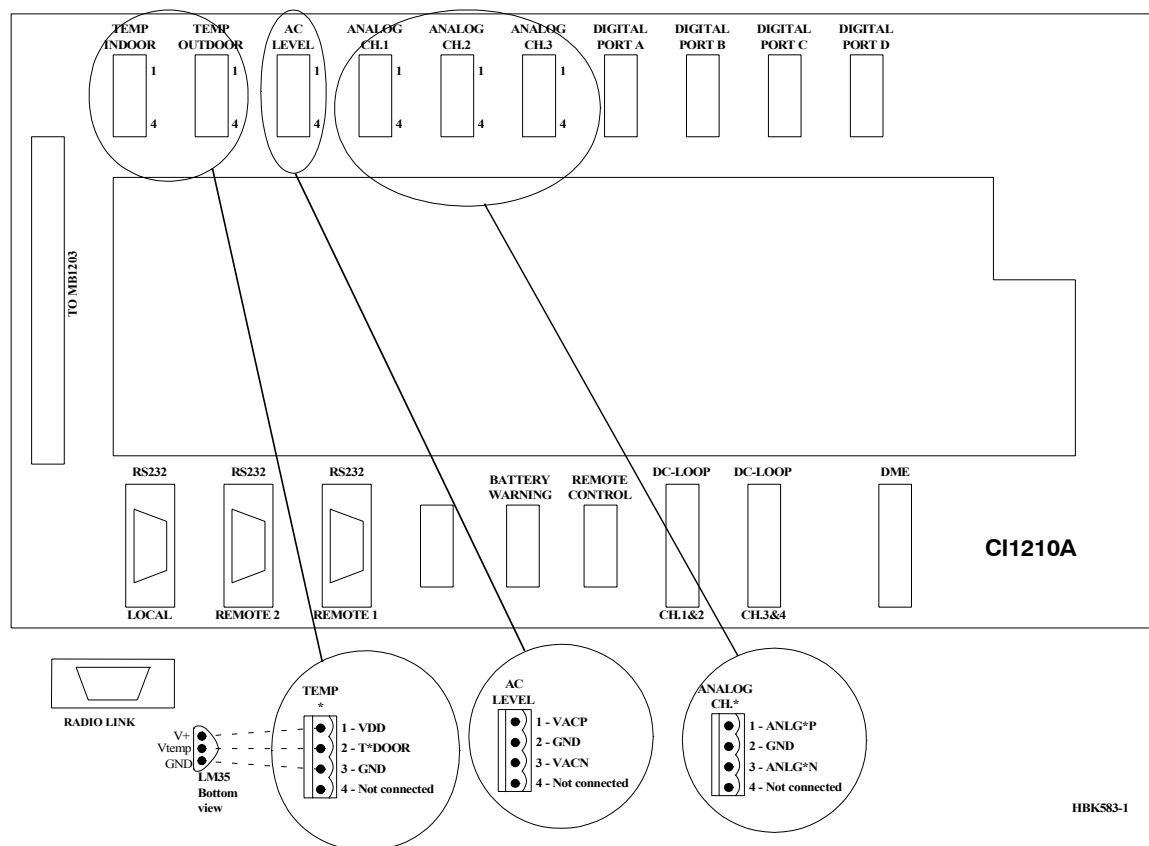

Figure4-9 Analog input connections.

4.10 Digital Inputs and Outputs

Eight bidirectional digital channels (numbered 0-7) are located on the Connection Interface board C11210A as illustrated in Figure 4-10

Logic levels: TTL.

Input impedance: 560ohms.

Suitable female connectors are Weidemüller *BLZ-5.08/4* or equivalent.

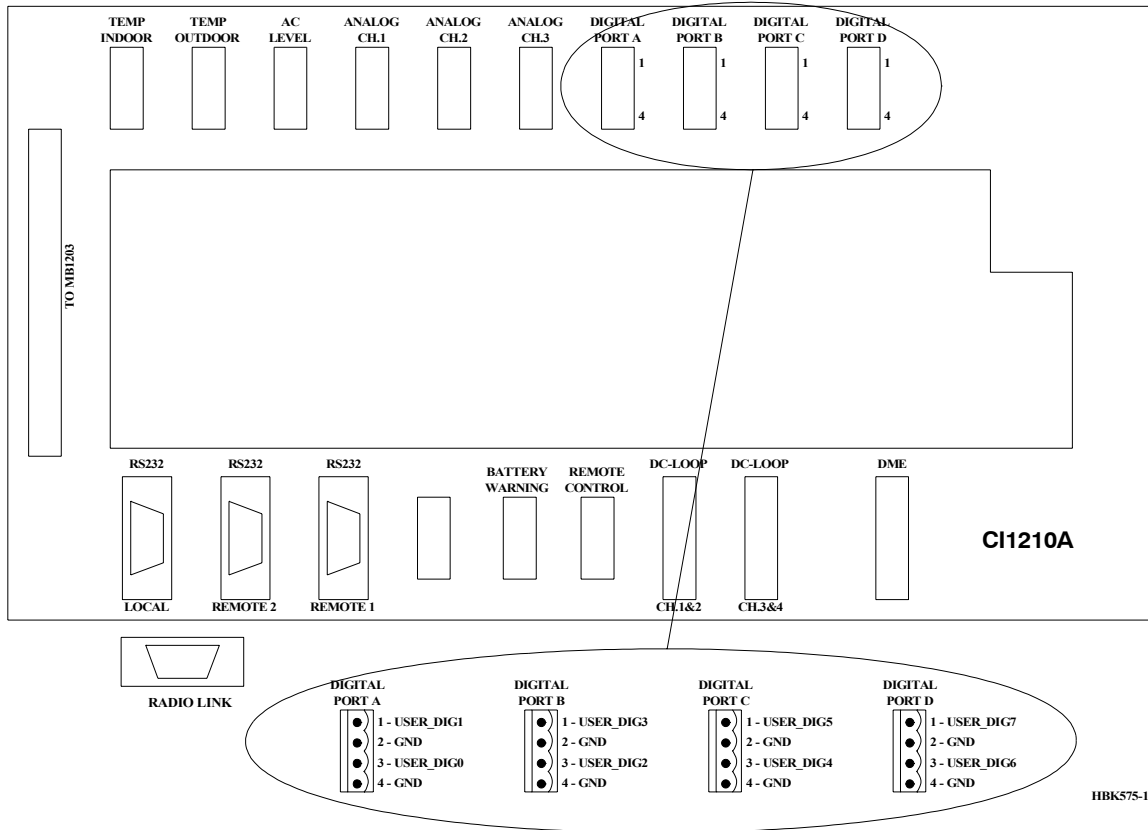

Figure4-10 Digital input/output connections.

4.11 Battery Warning

Two inputs for main power supply failure (backup battery active) are sited on the CI1210A connection interface board as illustrated in Figure 4-11

Logic levels: Normally high 5V or 0V =battery warning.

Input impedance: 10kohms.

Suitable female connectors are Weidemüller *BLZ-5.08/4* or equivalent.

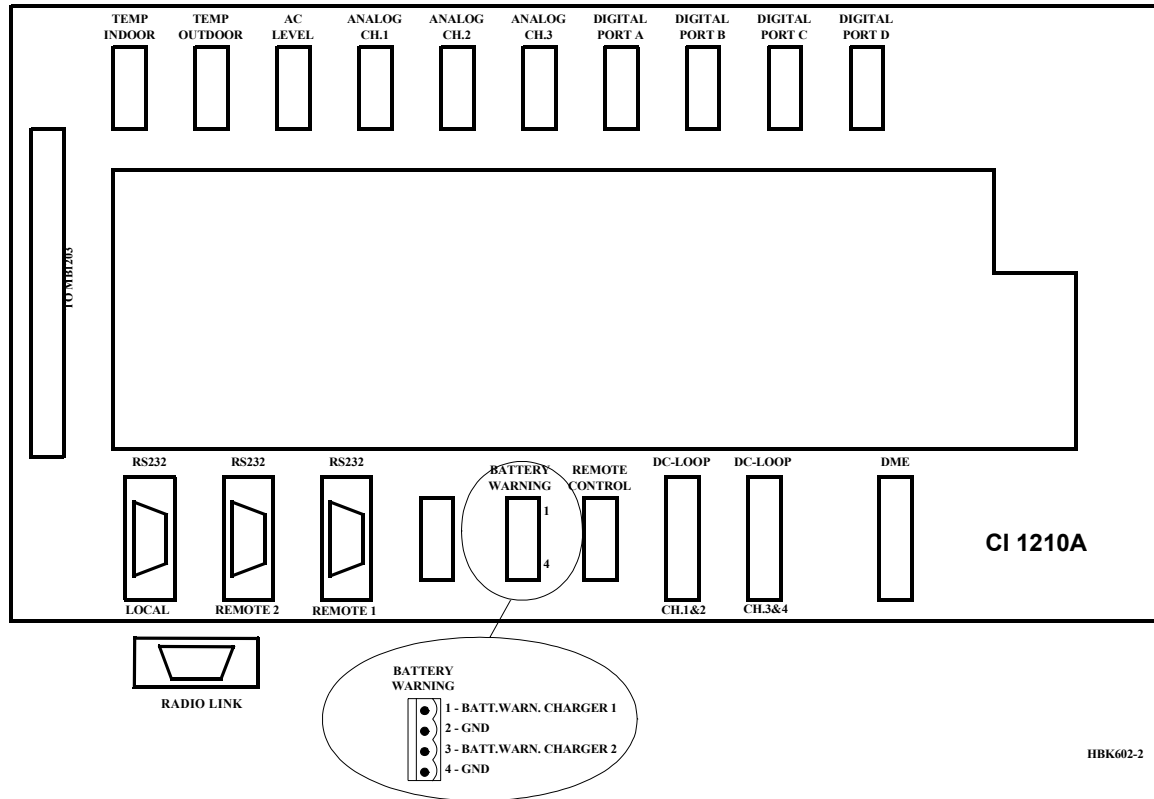

Figure4-11 Battery warning connections.

4.12 Remote control connections

The remote control is connected to the corresponding ILS by connecting the REMOTE CONTROL connector on Connection Interface CI1210 to P9 on Motherboard MB1346, as shown in Figure 4-12.

Suitable female connectors are Weidemüller *BLZ-5.08/4* or equivalent. 600 ohms cable should be used.

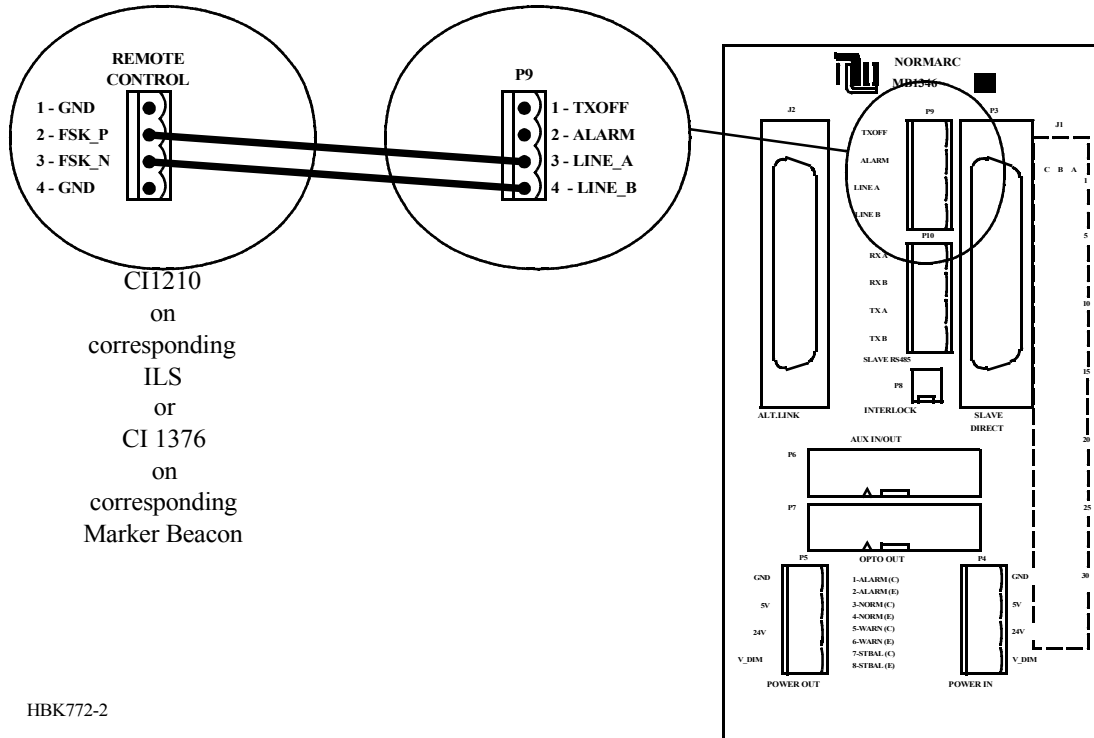

Figure4-12 Remote control to ILS connection

The power supply to the remote control is connected according to Figure 4-13. The battery charger is connected to P2 on the MB1347 - power supply motherboard. Output connector P3 on MB1347 is connected to input connector P4 on MB1346 - remote control motherboard. Several MB1346's are serial linked by connecting P5 on one board to P4 on the next.

Suitable female connectors are Weidemüller *BLZ-5.08/4* or equivalent.

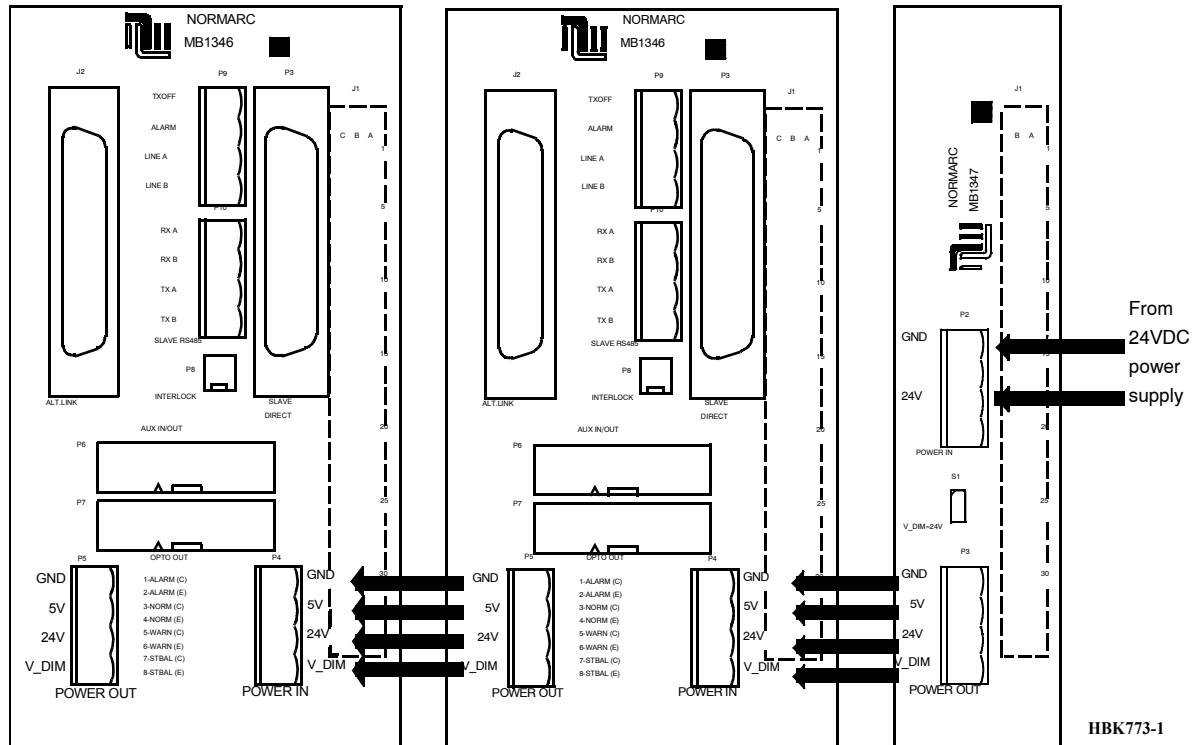

Figure 4-13 Remote control power supply connections

4.13 Remote slave connection

The remote slave panel SF1344 is connected to the corresponding remote control's motherboard by connecting P3 on MB1346 to P1 on SF1344. P10 on MB1346 is not used. See Figure 4-14.

Suitable connectors are standard 25 pins female DSUB (Harting 0967 025 0442 and 0967 225 4704 or equivalent), connected by a 10 wire 1:1 cable.

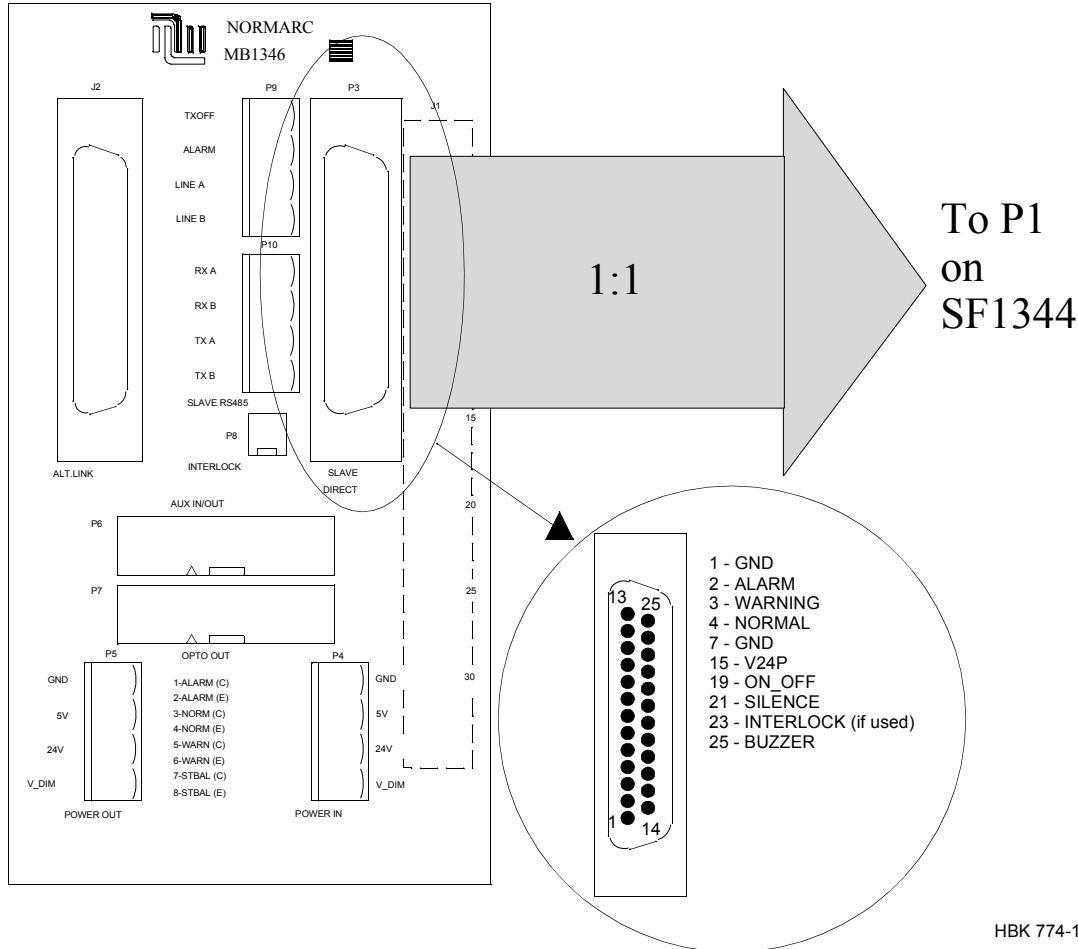

Figure4-14 Remote slave connection

4.14 Interlock switch connection

The interlock switch is either connected to P8 on MB1346 (remote control motherboard) or to P2 on SF1344 (remote slave panel), see Figure 4-15.

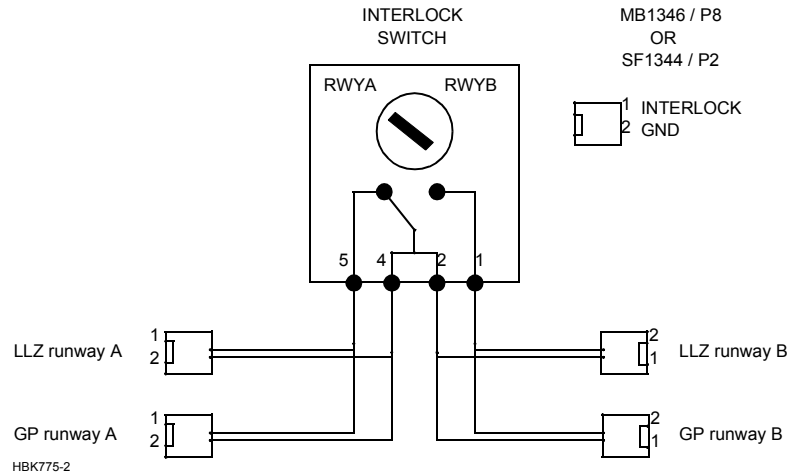

Figure 4-15 Interlock switch connection

Note:

When MB1346A is used with Remote Control Assembly RCA1240C or D and Interlock function is not used (connected), a jumper plug must be installed in P8 (or P2).