



HEARTH PRODUCTS

This appliance may be installed in an aftermarket permanently located, manufactured home (USA only) or mobile home, where not prohibited by local codes. This appliance is only for use with the type of gas indicated on the rating plate. This appliance is not convertible for use with other gases, unless a certified kit is used.

In the Commonwealth of Massachusetts:

- Installation must be performed by a licensed plumber or gas fitter;
- See Table of Contents for location of additional Commonwealth of Massachusetts requirements.

WARNING: IF THE INFORMATION IN THIS MANUAL IS NOT FOLLOWED EXACTLY, A FIRE OR EXPLOSION MAY RESULT CAUSING PROPERTY DAMAGE, PERSONAL INJURY OR LOSS OF LIFE.

Do not store or use gasoline or other flammable vapors or liquids in the vicinity of this or any other appliance.

WHAT TO DO IF YOU SMELL GAS:

- Do not light any appliance.
- Do not touch any electrical switch; do not use any phone in your building.
- Immediately call your gas supplier from a neighbor's phone. Follow your gas supplier's instructions.
- If your gas supplier cannot be reached, call the fire department.

Installation and service must be performed by a qualified installer, service agency or the gas supplier.

Tested & Listed By  Beaverton Oregon USA
OMNI-Test Laboratories, Inc.

OTL Report No. 116-F-31-5

A French manual is available upon request. Order P/N 850,029CF

Ce manuel d'installation est disponible en français, simplement en faire la demande. Numéro de la pièce 850,029CF.

INSTALLATION INSTRUCTIONS

DIRECT VENT MERIT™ LMDV-33/35/40 SERIES

VENTED GAS FIREPLACE HEATERS - DIRECT VENT MODELS
P/N 850,029M REV. G 05/2008

MODELS

Millivolt Models

LMDVT-3328-CNM LMDV-3530-CNM
LMDVT-3328-CPM LMDV-3530-CPM
LMDVR-3328-CNM LMDV-4035-CNM
LMDVR-3328-CPM LMDV-4035-CPM

Electronic Models

LMDVT-3328-CNE
LMDVR-3328-CNE
LMDV-3530-CNE
LMDV-4035-CNE

INSTALLER: Leave this manual with the appliance.
CONSUMER: Retain this manual for future reference.

AVERTISSEMENT: ASSUREZ-VOUS DE BIEN SUIVRE LES INSTRUCTIONS DONNÉ DANS CETTE NOTICE POUR RÉDUIRE AU MINIMUM LE RISQUE D'INCENDIE OU POUR ÉVITER TOUT DOMMAGE MATÉRIEL, TOUTE BLESSURE OU LA MORT.

POUR VOTRE SÉCURITÉ: Ne pas entreposer ni utiliser d'essence ni d'autre vapeurs ou liquides inflammables dans le voisinage de cet appareil ou de tout autre appareil.

POUR VOTRE SÉCURITÉ: Que faire si vous sentez une odeur de gaz:

- Ne pas tenter d'allumer d'appareil.
- Ne touchez à aucun interrupteur. Ne pas vous servir des téléphones se trouvant dans le bâtiment où vous vous trouvez.
- Evacuez la pièce, le bâtiment ou la zone.
- Appelez immédiatement votre fournisseur de gaz depuis un voisin. Suivez les instructions du fournisseur.
- Si vous ne pouvez rejoindre le fournisseur de gaz, appelez le service des incendies.

L'installation et service doit être exécuté par un qualifié installateur, agence de service ou le fournisseur de gaz.

TABLE OF CONTENTS

Packaging	Page 2
Introduction	Page 2
General Information	Page 2
New York City Approval.....	Page 3
Requirements for the Commonwealth of Massachusetts	Page 4
Cold Climate Insulation	Page 4
Location	Page 4
Manufactured Home Requirements	Page 5
Vent Termination Clearances	Page 5
Appliance and Vent Clearances	Page 7
Detailed Installation Steps.....	Page 8
Typical Installation Sequence	Page 8
Step 1. Framing.....	Page 8
Step 2. Routing Gas Line	Page 8
Fireplace Specifications.....	Page 9
Step 3. Install the Venting System	Page 11
Vertical Termination Systems.....	Page 12
Vent Section Length Chart	Page 12
Vertical Vent Tables and Figures.....	Page 14
Horizontal Termination System	Page 16
Horizontal Vent Tables and Figures	Page 19
Venting Using Flexible Vent Pipe.....	Page 22
Step 4. Field Wiring.....	Page 23
Step 5. Optional Blower Kit Wiring	Page 23
Step 6. Connecting Gas Line	Page 24
Step 7. Checking Unit Operation	Page 25
Step 8. Installing Logs	Page 26
Step 9. Installing Glass Door	Page 29
Step 10. Burner Adjustments	Page 29
Step 11. Hood Installation.....	Page 30
Finishing Requirements	Page 30
Installation Accessories	Page 31
Gas Conversion Kits	Page 34

This manual is part of a set of two supporting this product. Refer to manual 875,028M for Care & Operation information.

Please read and understand these instructions before beginning your installation.

The **Millivolt** appliances have a millivolt gas control valve with piezo ignition system which provides safe, efficient operation. If any optional accessories that will require electrical power are to be installed, the electrical power must be provided at the time of appliance installation.

The **Electronic** appliances have an electronic intermittent pilot ignition system which provides safe, efficient operation. External electrical power is required to operate these appliances.



We recommend that our gas hearth products be installed and serviced by professionals who are certified in the U.S. by the National Fireplace Institute® (NFI) as NFI Gas Specialists.

PACKAGING

The assembled vented gas fireplace heater is packaged with:

- 1 - One log set located in firebox area.
- 2 - One envelope containing the literature package which consists of the homeowner's manual, installation instructions, and warranty; envelope is located in the control compartment.
- 3 - One vent restrictor to be applied as shown on **Page 11**; restrictor is taped to the envelope.
- 4 - One hood located behind the top panel.
- 5 - One bag of decorative volcanic stone located in the control compartment.
- 6 - One bag of glowing embers located in the control compartment.
- 7 - One bag of vermiculite located in the control compartment.

INTRODUCTION

These vented gas fireplace heaters are sealed combustion, air circulating gas fireplaces designed for residential applications.

Approved Vent Components - These fireplaces are designed, tested and listed for operation and installation with, the following vent components only:

- **Secure Vent™** Direct Vent System Components,
- **Secure Flex™** Flexible Vent Components manufactured by Security Chimneys International and
- **Z-FLEX™** Model GA Venting Systems listed to UL1777 and ULCS635 manufactured by Flexmaster Canada Limited.

These approved vent system components are labeled for identification. DO NOT use any other manufacturer's vent components with these appliances. Use only the correct size venting (4-1/2" inner & 7-1/2" outer).

These appliances comply with National Safety Standards and are tested and listed by OMNI-Test Laboratories, Inc. (Report No. 116-F-31-5) to ANSI Z21.88b (in Canada, CSA-2.33b), and CAN/CGA-2.17-M91 in both USA and Canada, as vented gas fireplace heaters.

Both millivolt and electronic versions of these appliances are listed by OMNI-Test Laboratories for installation in bedrooms and Manufactured Homes.

Manufactured Homes -

See **Manufactured Home Requirements** on **Page 5** for additional information.

! WARNING

Improper installation, adjustment, alteration, service or maintenance can cause injury or property damage. Refer to this manual. For assistance or additional information consult a qualified installer, service agency or the gas supplier.

This appliance is only for use with the type of gas indicated on the rating plate. This appliance is not convertible for use with other gases, unless a certified kit is used.

Cet appareil doit être utilisé uniquement avec les types de gaz indiqués sur la plaque signalétique. Ne pas l'utiliser avec d'autres gaz sauf si un kit de conversion certifié est installé.

Misc. Codes / Standards -

Installation must conform to local codes. In the absence of local codes, installation must comply with the current National Fuel Gas Code, ANSI Z223.1. (In Canada, the current CAN-1 B149 installation code).

The appliance, when installed, must be electrically grounded & wired in accordance with local codes or, in the absence of local codes, with the National Electrical Code, ANSI / NFPA 70-latest edition, or the Canadian Electrical Code, CSA C22.1 - latest edition.

GENERAL INFORMATION

Note: Installation and repair should be performed by a qualified service person. The appliance should be inspected annually by a qualified professional service technician. More frequent inspections and cleanings may be required due to excessive lint from carpeting, bedding material, etc.

S'assurer que le brûleur et le compartiment des commandes sont propres. Voir les instructions d'installation et d'utilisation qui accompagnent l'appareil.

Provide adequate clearances around air openings and adequate accessibility clearance for service and proper operation. Never obstruct the front openings of the appliance.

These appliances are designed to operate on natural or propane gas only. The use of other fuels or combination of fuels will degrade the performance of this system and may be dangerous.

These fireplaces are designed as supplemental heaters. Therefore, it is advisable to have an alternate heat source when installed in a dwelling.

Millivolt Models - The millivolt appliances are manually controlled and feature a spark igniter (piezo) that allows the appliance's pilot gas to be lit without the use of matches or batteries. This system provides continued service in the event of a power outage.

Millivolt models come standard with a manually-modulated gas valve; flame appearance and heat output can be controlled at the gas valve. The BTU Input for these appliances is shown in **Tables 1 & 2**.

Input (BTU) Manually-Modulated Gas Valves (millivolt models)	
NATURAL GAS	
Models	Input Rate (BTU / HR)
LMDVT-3328CNM LMDVR-3328CNM	17,500 high 11,700 low
LMDV-3530CNM	20,000 high 12,800 low
LMDV-4035CNM	27,000 high 18,500 low

Table 1

Input (BTU) Manually-Modulated Gas Valves (millivolt models)	
PROPANE GAS	
Models	Input Rate (BTU / HR)
LMDVT-3328CPM LMDVR-3328CPM	17,500 high 14,000 low
LMDV-3530CPM	20,000 high 15,200 low
LMDV-4035CPM	27,000 high 21,500 low

Table 2

Electronic Models -
Electronic models have a fixed rate gas valve. Input of electronic models is shown in **Table 3**.

Electronic Models with Fixed Rate Gas Valve	
Natural and Propane Gas	
Model Series	Input Rate (BTU / HR)
LMDVT-3328 LMDVR-3328	17,500
LMDV-3530	20,000
LMDV-4035	27,000

Table 3

Gas Pressure - All Models
Tables 4, 5 and 6 show the appliances' gas pressure requirements:

Inlet Gas Supply Pressure (all models)		
Fuel #	Minimum	Maximum
Natural Gas	5.0" WC (1.24 kPa)	10.5" WC (2.61 kPa)
Propane	11.0" WC (2.74 kPa)	13.0" WC (3.23 kPa)

Table 4

Manifold Gas Supply Pressure (millivolt models)		
Fuel #	Low	High
Natural Gas	(Lo) 2.2" WC (.55 kPa)	(Hi) 3.5" WC (.87 kPa)
Propane	(Lo) 6.3" WC (1.57 kPa)	(Hi) 10.0" WC (2.49 kPa)

Table 5

Manifold Gas Supply Pressure (electronic models)	
Fuel #	Maximum Manifold Pressure
Natural Gas	(Hi) 3.5" WC (.87 kPa)
Propane	(Hi) 10.0" WC (2.49 kPa)

Table 6

Test gauge connections are provided on the front of the millivolt gas control valve, identified IN for the inlet and OUT for the manifold side. A 1/8" NPT Test gauge connection is provided at the inlet and outlet side of the electronic gas control valve.

These appliances must be isolated from the gas supply piping system (*by closing their individual manual shut-off valve*) during any pressure testing of the gas supply piping system at test pressures equal to or **less than** 1/2 psig (3.5 kPa).

These appliances and their individual shut-off valves *must be disconnected* from the gas supply piping system during any pressure testing of that system at pressures **greater than** 1/2 psig (3.5 kPa).

Orifice Sizes - Sea Level to High Altitude (All Models)

These appliances are tested and approved for installation at elevations of 0-4500 feet (0-1372 meters) above sea level using the standard burner orifice sizes (marked with an "*" in **Table 7**). For elevations above 4500 feet, contact your gas supplier or qualified service technician .

Burner Orifice Sizes Elevation 0-4500 feet (0-1372 meters)		
Model Series	Nat. Gas drill size (inches)	Propane drill size (inches)
LMDVT-3328 LMDVR-3328	#45 (.082") * 39L66 •	(.048") * 99K780 •
LMDV-3530	#44 (.086") * 60J8001 •	#55 (.052") * 19L5201 •
LMDV-4035	#37 (.104") * 24M1001 •	1/16" (.062")* 21L0101 •

Table 7 * Standard size installed at factory
• Part/Cat. Number

Install the appliance according to the regulations of the local authorities having jurisdiction and, in the USA, the National Fuel Gas Code NFPA 54 / ANSI Z223.1 - latest edition or, in Canada, the CAN1-B149.1 and .2 codes - latest edition.

Gas Valve Diagrams

See **Figures 1 & 2** for Millivolt models and **Figure 3** For Electronic Models.

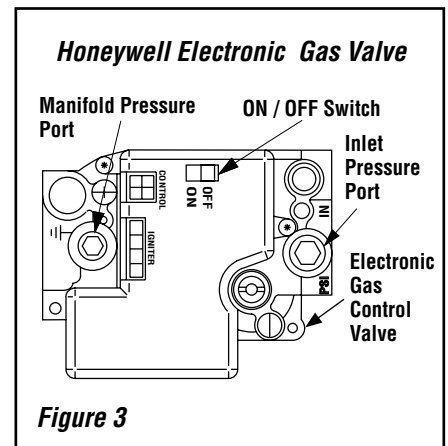
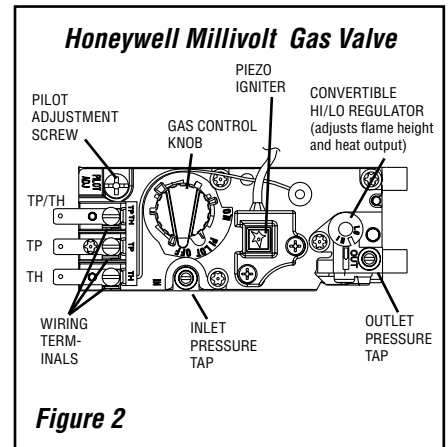
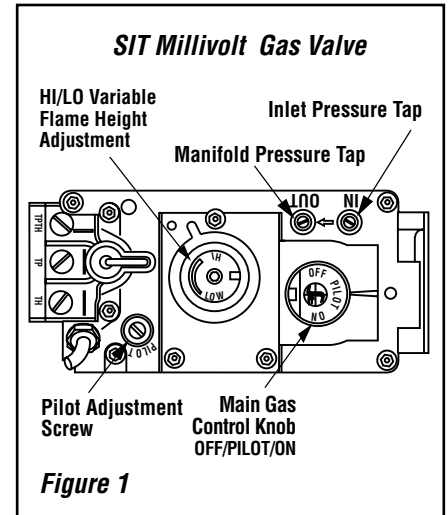

Massachusetts And New York City, NY Requirements

These appliances are approved for installation in the following USA locations listed in the following:

Massachusetts:

These fireplaces are approved for installation in the US state of Massachusetts if the following additional requirements are met-

- Installation and repair must be done by a plumber or gas fitter licensed in the Commonwealth of Massachusetts.
- The flexible gas line connector used shall not exceed 36 inches (92 centimeters) in length.
- The individual manual shut-off must be a T-handle type valve.

Massachusetts Horizontal Vent Requirements

In the Commonwealth of Massachusetts, horizontal terminations installed less than seven (7) feet above the finished grade must comply with the following additional requirements:

- A hard wired carbon monoxide detector with an alarm and battery back-up must be installed on the floor level where the gas fireplace is installed. The carbon monoxide detector must comply with NFPA 720, be ANSI/UL 2034 listed and be ISA certified.
- A metal or plastic identification plate must be permanently mounted to the exterior of the building at a minimum height of eight (8) feet above grade and be directly in line with the horizontal termination. The sign must read, in print size no less than one-half (1/2) inch in size, GAS VENT DIRECTLY BELOW. KEEP CLEAR OF ALL OBSTRUCTIONS.

New York City, NY:

These fireplaces are approved for installation in New York City in the US state of New York.

COLD CLIMATE INSULATION

For cold climate installations, seal all cracks around the appliance with noncombustible material and wherever cold air could enter the room. It is especially important to insulate outside chase cavity between studs and under floor on which the appliance rests, if floor is above ground level. Gas line holes and other openings should be caulked or stuffed with unfaced fiberglass insulation. If the fireplace is being installed on a cement slab, in cold climates, a sheet of plywood or other raised platform can be placed underneath to prevent conducting cold up into the room. It also helps to sheetrock inside surfaces and tape for maximum air tightness and caulk firestops.

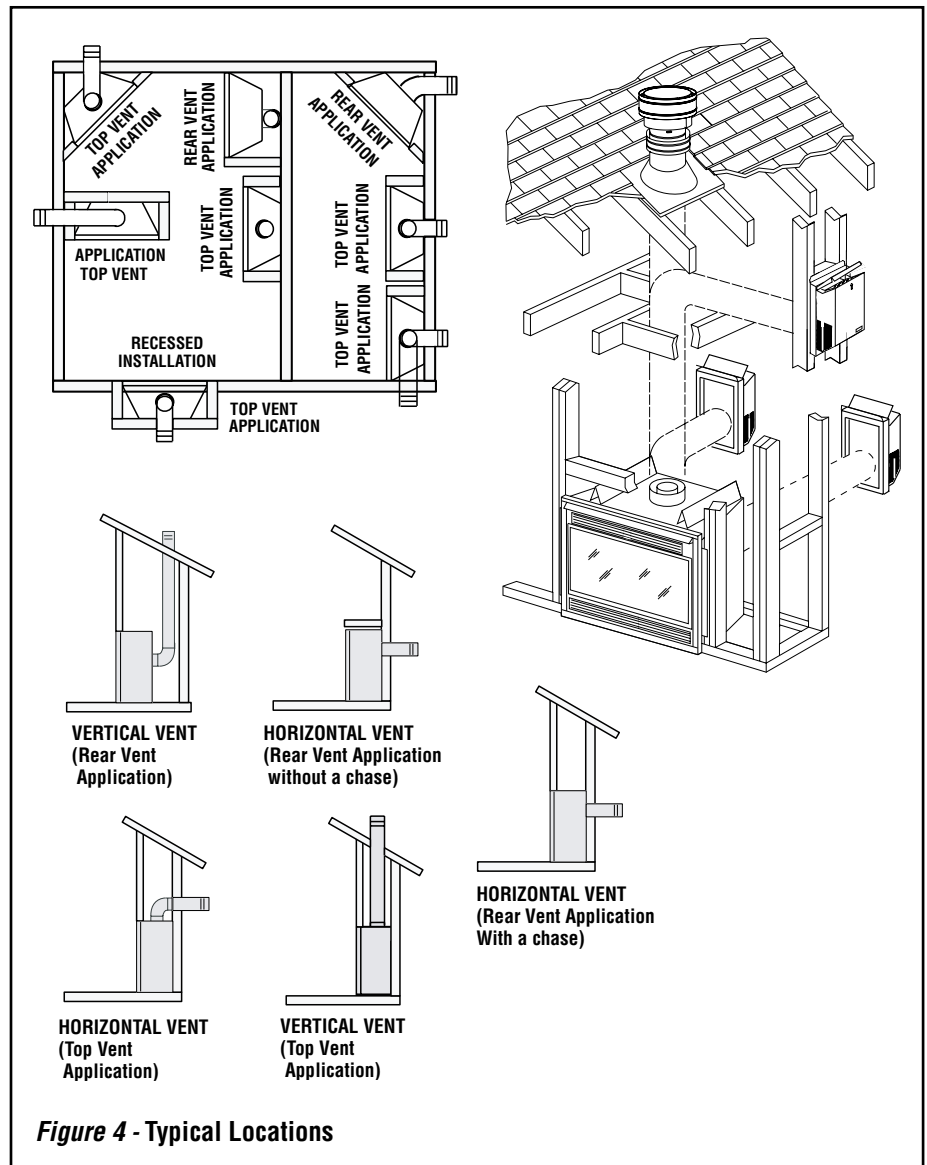

Figure 4 - Typical Locations

LOCATION

In selecting the location, the aesthetic and functional use of the appliance are primary concerns. However, vent system routing to the exterior and access to the fuel supply are also important. Consideration should be given to traffic ways, furniture, draperies, etc., due to elevated surface temperatures (Figure 4). The location should also be free of electrical, plumbing or other heating/air conditioning ducting.

These direct vent appliances are uniquely suited for installations requiring a utility shelf positioned directly above the fireplace. Utility shelves like these are commonly used for locating television sets and decorative plants. **Be aware that this is a heat producing appliance. Objects placed above the unit are exposed to elevated temperatures.**

To provide for the lowest possible shelf surface use the alternate rear vent outlet with attached venting routed in a way to minimize obstructions to the use of the space above the appliance. **Do not insulate the space between the appliance and the area above it. See Figure 9.** The minimum height from the base of the appliance to the underside of combustible materials used to construct a utility shelf in this fashion is shown in the Table in Figure 9.

The appliance should be mounted on a fully supported base extending the full width and depth of the unit. The appliance may be located on or near conventional construction materials. However, if installed on combustible materials, such as carpeting, vinyl tile, etc., a metal or wood barrier covering the entire bottom surface must be used.

MANUFACTURED HOME REQUIREMENTS

This appliance may be installed in an after-market permanently located, manufactured home (USA only) or mobile home, where not prohibited by local codes.

Cet appareil peut être installé dans un maison préfabriquée (É.-U. seulement) ou mobile déjà installée à demeure si les règlements locaux le permettent.

Manufactured Home installations must be installed in accordance with these instructions and the following standards / codes:

- Manufactured Home Construction and Safety Standard Title 24 CFR, Part 3280, or the current Standard for Fire Safety Criteria for Manufactured Home Installations, Sites and Communities ANSI / NFPA 501A in the USA, and CAN / GSA Z240 MH Mobile Home Standard in Canada
- (when applicable) The American National Standard for Manufactured Homes (NCSBCS / ANSI A225.1 - latest edition).

CAUTIONS

Ensure that the cross members are not cut or weakened during installation. The structural integrity of the manufactured home floor, wall, and ceiling / roof must be maintained.

This appliance must be grounded to the chassis of the manufactured home in accordance with local codes or in the absence of local codes, with the National Electrical Code ANSI / NFPA 70 - latest edition or the Canadian Electrical Code CSA C22.1 - latest edition.

VENT TERMINATION CLEARANCES

These instructions should be used as a guideline and do not supersede local codes in any way. Install vent according to local codes, these instructions, the current National Fuel Gas Code (ANSI-Z223.1) in the USA or the current standards of CAN/CGA-B149.1 and -B149.2 in Canada.

Terminate multiple vent terminations according to the installation codes listed above.

Terminate single vent caps relative to building components according to **Figure 5**.

Vertical Vent Termination Clearances

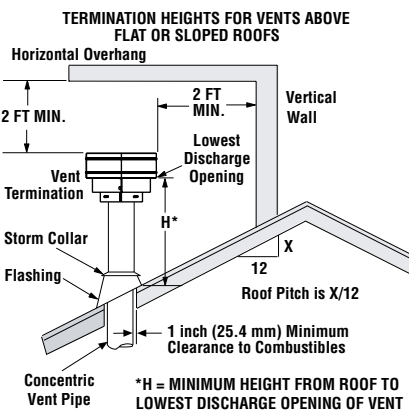

The vent / air intake termination clearances above the high side of an angled roof is as shown in the following chart:

Termination Heights For Vents Above Flat Or Sloped Roofs Ref. NFPA 54 / ANSI Z223.1, 7.6

Roof Pitch	* Feet	* Meters
Flat to 6/12	1.0	0.3
6/12 to 7/12	1.25	0.38
7/12 to 8/12	1.5	0.46
8/12 to 9/12	2.0	0.61
9/12 to 10/12	2.5	0.76
10/12 to 11/12	3.25	0.99
11/12 to 12/12	4.0	1.22
12/12 to 14/12	5.0	1.52
14/12 to 16/12	6.0	1.83
16/12 to 18/12	7.0	2.13
18/12 to 20/12	7.5	2.29
20/12 to 21/12	8.0	2.44

Figure 5

Horizontal Vent Termination Clearances

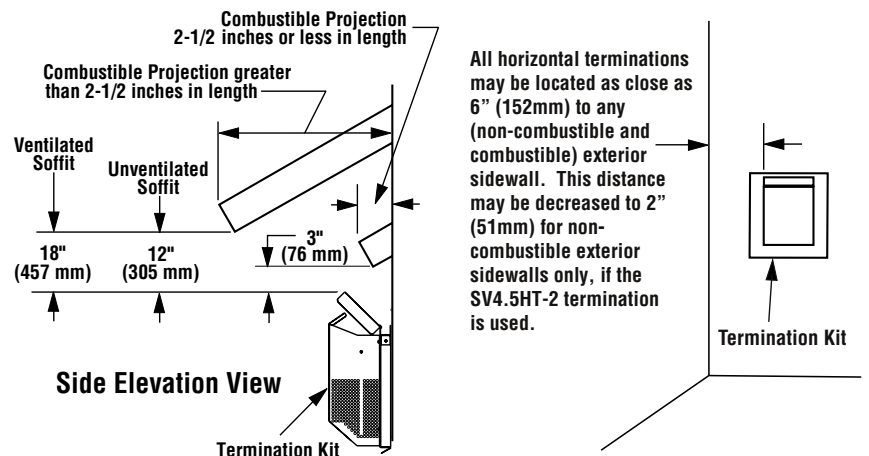

Figure 6

Note - See Figure 35 on Page 20 for the exterior wall recess allowances of the square horizontal termination.

Horizontal Vent Termination Clearances

The horizontal vent termination must have a minimum of 3" (76 mm) clearance to any overhead combustible projection of 2 1/2" (64 mm) or less. See **Figure 6**. For projections exceeding 2 1/2" (64 mm), see **Figure 6**. For additional vent location restrictions refer to **Figure 7 on Page 8**.

EXTERIOR HORIZONTAL VENT TERMINATION CLEARANCE REQUIREMENTS

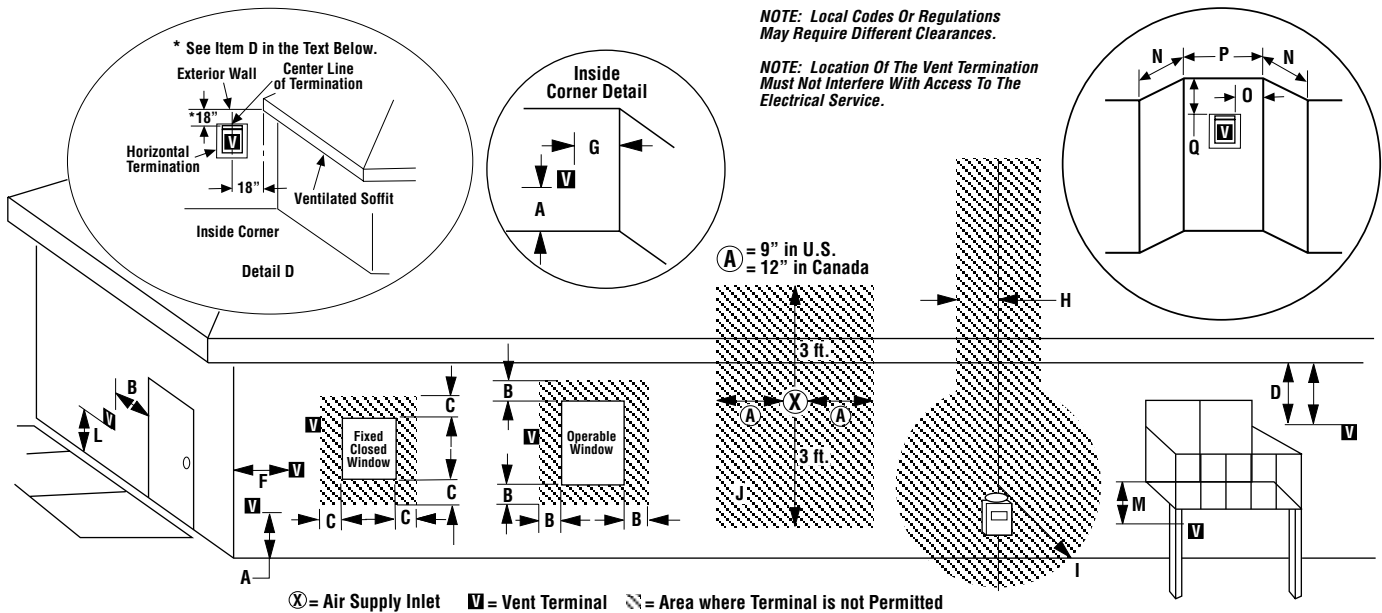

NOTE: Local Codes Or Regulations May Require Different Clearances.
 NOTE: Location Of The Vent Termination Must Not Interfere With Access To The Electrical Service.

	Canadian Installation*	US Installation**
A = Clearance above grade, veranda, porch, deck, or balcony.	12 inches (30cm)*	12 inches (30cm)**
B = Clearance to window or door that may be opened.	6 inches (15cm) for appliances < 10,000 Btuh (3kW), 12 inches (30cm) for appliances > 10,000 Btuh (3kW)	6 inches (15cm) for appliances < 10,000 Btuh (3kW), 9 inches (23cm) for appliances > 10,000 Btuh (3kW) and < 50,000 Btuh (15kW), 12 inches (30cm) for appliances > 50,000 Btuh (15kW)**
C = Clearance to permanently closed window	12 inches (305mm) recommended to prevent window condensation	9 inches (229mm) recommended to prevent window condensation
D = Vertical clearance to ventilated soffit located above the terminal within a horizontal distance of 18 inches (458mm) from the center line of the terminal	18 inches (458mm)	18 inches (458mm)
E = Clearance to unventilated soffit***	12 inches (305mm)	12 inches (305mm)
F = Clearance to outside corner	5 inches (12.7cm) minimum	5 inches (12.7cm) minimum
G = Clearance to inside corner	6 inches (15.2cm) minimum	6 inches (15.2cm) minimum
H = Clearance to each inside of center line extended above meter/regulator assembly	3 feet (91cm) within a height of 15 feet above the meter/regulator assembly*	3 feet (91cm) within a height of 15 feet above the meter/regulator assembly**
I = Clearance to service regulator vent outlet	3 feet (91cm)*	3 feet (91cm)**
J = Clearance to nonmechanical air supply inlet to building or the combustion air inlet to any other appliance	6 inches (15cm) for appliances < 10,000 Btuh (3kW), 12 inches (30cm) for appliances > 10,000 Btuh (3kW)	6 inches (15cm) for appliances < 10,000 Btuh (3kW), 9 inches (23cm) for appliances > 10,000 Btuh (3kW) and < 50,000 Btuh (15kW), 12 inches (30cm) for appliances > 50,000 Btuh (15kW)**
K = Clearance to a mechanical air supply inlet	6 feet (1.83m)*	3 feet (91cm) above if within 10 feet (3m) horizontally**
L = Clearance above paved sidewalk or paved driveway located on public property	7 feet (2.13m)‡	7 feet (2.13m)‡
M = Clearance under veranda, porch, deck or balcony	12 inches (30cm)*‡	12 inches (30cm)‡
N = Depth of Alcove (Maximum)	6 feet (1.83m)*	6 feet (1.83m)**
O = Clearance to Termination (Alcove)	6 inches (15.2mm)*	6 inches (15.2mm)**
P = Width of Alcove (Minimum)	3 feet (91cm)*	3 feet (91cm)*
Q = Clearance to Combustible Above (Alcove)	18 inches (457mm)*	18 inches (457mm)**

* In accordance with the current CSA-B149.1 National Gas And Propane Installation Code.
 ** In accordance with the current ANSI S2223.1/NFPA 54 National Fuel Gas Codes.
 *** Clearance required to vinyl soffit material - 30 inches (76cm) minimum.
 ‡ A vent shall not terminate directly above a sidewalk or paved driveway which is located between two single family dwellings and serves both dwellings.
 †‡ Only permitted if veranda, porch, deck or balcony is fully open on a minimum 2 sides beneath the floor:

Figure 7

NOTE: DIAGRAMS & ILLUSTRATIONS ARE NOT TO SCALE.

MINIMUM CLEARANCES TO COMBUSTIBLES

Hearth Extension A hearth extension is not required with this appliance. If a hearth extension is used, do not block the lower control compartment door. Any hearth extension used is for appearance only and does not have to conform to standard hearth extension installation requirements.

Wall Finishes / Surrounds / Mantels

Note: Combustible wall finish materials and/or surround materials must not be allowed to encroach the area defined by the appliance front face (black sheet metal). **Never allow combustible materials to be positioned in front of or overlapping the appliance front face.** See **Figure 61 on Page 30.**

Non-combustible materials, such as surrounds and other appliance trim, may be installed on the appliance front face with these exceptions: they must not cover any portion of the removable glass panel or louvers.

Vertical installation clearances to combustible mantels vary according to the depth of the mantel. See **Figure 8.** Mantels constructed of non-combustible materials may be installed at any height above the appliance opening; however, do not allow anything to hang below the hood.

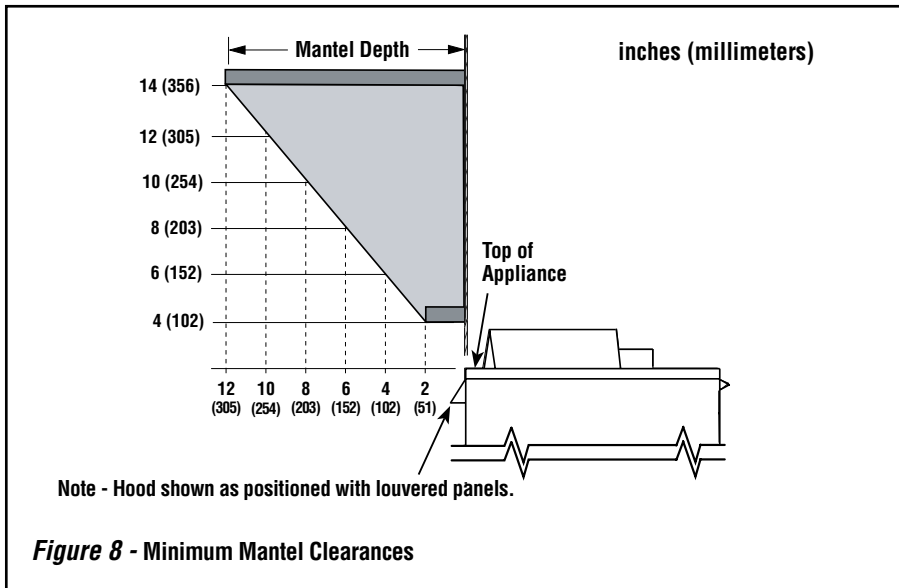

Appliance and Vent Clearances

The appliance is approved with zero clearance to combustible materials on all sides (as detailed in **Table 8**), with the following exception: When the unit is installed with one side flush with a wall, the wall on the other side of the unit must not extend beyond the front edge of the unit. In addition, when the unit is recessed, the side walls surrounding the unit must not extend beyond the front edge of the unit. See **Figure 4.**

MINIMUM CLEARANCES Inches (millimeters)	
Back	1/2 (13) 0 (0) Spacers
Sides	1/2 (13) 0 (0) Spacers
Top Spacers	0 (0)
Floor	0 (0)
Bottom of Appliance To Ceiling	64 (1626)
Vent	3 (76) Top * 1 (25.4) Sides & Bottom
SERVICE CLEARANCES Feet (meters)	
Front	3 ft. (0.9 m)

Table 8

*Note: 3 in. (75 mm) above any horizontal/inclined vent component.

**Note: See Page 8, Step 1 for clearance requirements to the nailing flange located at each side of the unit and any screw heads adjacent to it.

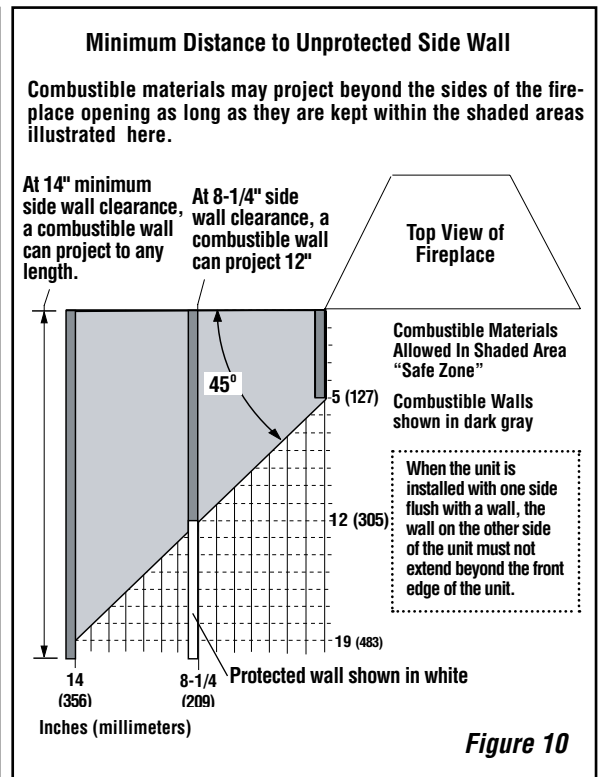
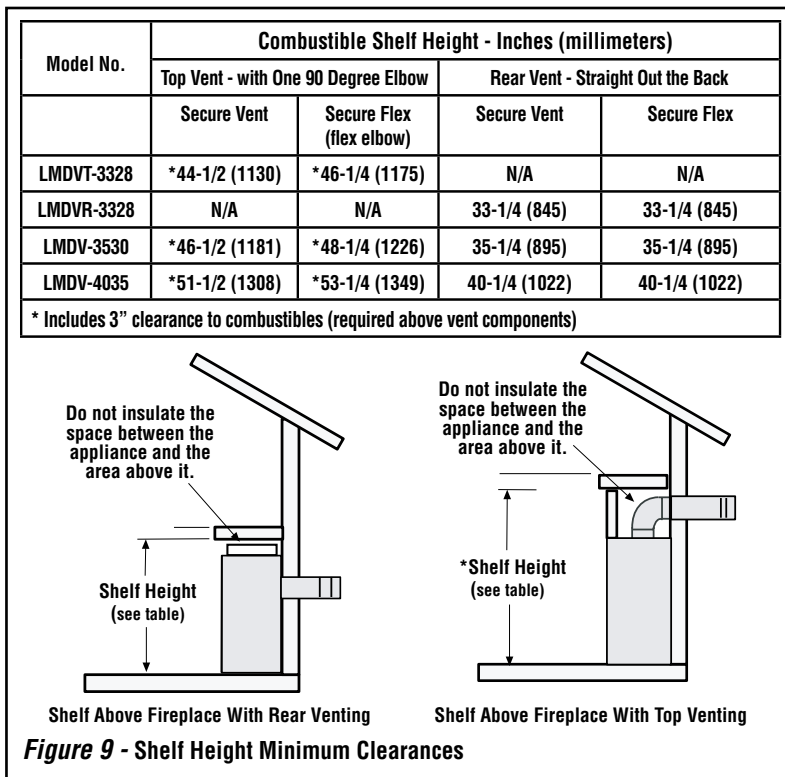

DETAILED INSTALLATION STEPS

The appliance is shipped with all gas controls and components installed and pre-wired. Remove the shipping carton, exposing the front glass door. Remove the top and bottom louvered control panel per instructions on **Page 25** (see *Control Compartment Access / Louver Panel Instructions*). **Remove the cardboard from underneath the pressure relief plates (in area behind top louver panel, See Figure 11).** Open the two latches (located under the firebox floor) securing the glass door. Remove the door by tilting it outward at the bottom and lifting it up. Set the door aside protecting it from inadvertent damage. See **Figure 57 on Page 29**.

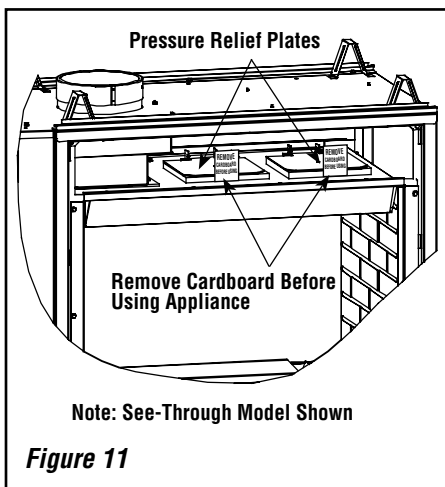

TYPICAL INSTALLATION SEQUENCE

The typical sequence of installation follows, however, each installation is unique resulting in variations to those described.

See the Page numbers references in the following steps for detailed procedures.

Step 1. (Page 8) Construct the appliance framing. Position the appliance within the framing and secure with nailing brackets.

Step 2. (Page 8) Route gas supply line to appliance location.

Step 3. (Page 11) Install the vent system and exterior termination.

Step 4. (Page 23) Field Wiring

a. Millivolt Appliances – Install the operating control switch (not factory provided) and bring in electrical service line for forced air circulating blower (optional equipment).

b. Electronic Appliances – Field wire and install operating control switch.

Step 5. (Page 23) Install blower kit (optional equipment).

Step 6. (Page 24) Make connection to gas supply.

Step 7. (Page 25) Install the logs, decorative volcanic stone and glowing embers.

Step 8. (Page 26) Checkout appliance operation.

Step 9. (Page 29) Install glass door frame assembly.

Step 10. (Page 29) Adjust burner to ensure proper flame appearance.

Step 11. (Page 30) Install the hoods.

Step 1. FRAMING

Frame these appliances as illustrated in **Figures 14 & 15 on Pages 9 & 10** (**Figure 15** applies to corner framing installations only). All framing details must allow for a minimum clearance to combustible framing members as shown in **Table 8 on Page 7**.

If the appliance is to be elevated above floor level, a solid continuous platform must be constructed.

Headers may be in direct contact with the appliance top spacers but must not be supported by them or notched to fit around them. All construction above the appliance must be self supporting. **DO NOT** use the appliance for structural support.

The fireplace should be secured to the side framing members using the unit's nailing flanges - one top and bottom on each side of the fireplace front. See **Figure 12**. Use 8d nails or their equivalent.

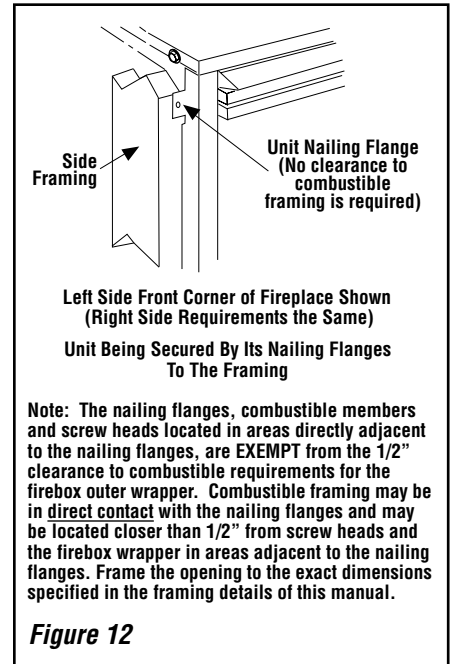

Step 2. ROUTING GAS LINE

Route a 1/2" (13 mm) gas line along the inside of the right side framing as shown in **Figure 13**. Gas lines must be routed, constructed and made of materials that are in strict accordance with local codes and regulations. All appliances are factory-equipped with a flexible gas line connector and 1/2 inch shutoff valve. (See **Step 6 on Page 24**).

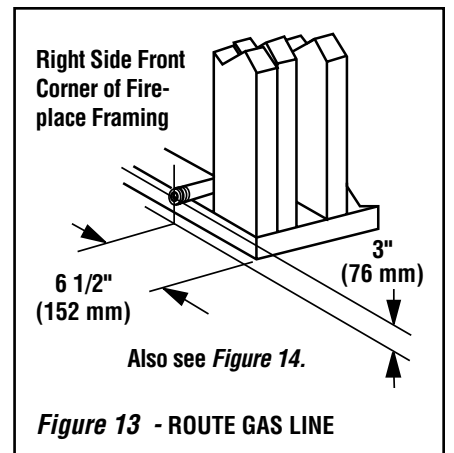

Continued on **Page 10**.

FIREPLACE SPECIFICATIONS

Framing

Framing Dimensions						
Model No.		A	B	C	D	E
LMDVT-3328	in.	33-1/4	33-1/4	-----	37-3/4	12-7/8
	mm	845	845	-----	959	327
LMDVR-3328	in.	33-1/4	33-1/4	19-5/8	-----	12-7/8
	mm	845	845	498	-----	327
LMDV-3530	in.	35-1/4	35-1/4	21-11/16	39-3/4	16
	mm	895	895	551	1010	406
LMDV-4035	in.	40-1/4	40-1/4	26-11/16	44-3/4	16
	mm	1022	1022	678	1137	406

Efficiencies %						
Models	Natural Gas			Propane		
	P4	Steady State	AFUE	P4	Steady State	AFUE
LMDVT-3328	45	64	62	49	66	64
LMDVR-3328	53	63	61	55	66	64
LMDV-3530	53	64	62	55	62	60
LMDV-4035	59	69	67	60	69	67

Notes

* The Steady State Efficiency numbers based on maximum vent configuration.

Due to Lennox' ongoing commitment to quality, all specifications, ratings and dimensions are subject to change without notice.

Input (BTU) - MV & Electronic	
Natural & Propane Gas	
Models	Input Rate (BTU / HR)
LMDVT-3328CPM LMDVR-3328CPM	17,500
LMDV-3530CPM	20,000
LMDV-4035CPM	27,000

Vent Size	
Co-axial DV Vent Size	4-1/2" Inner / 7-1/2" Outer

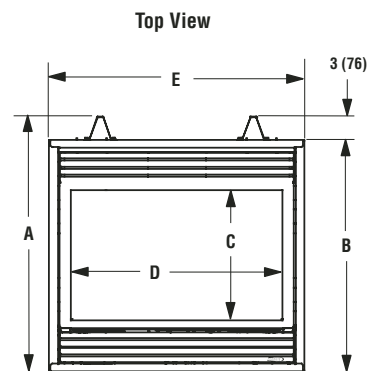
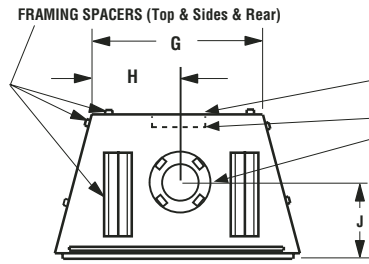
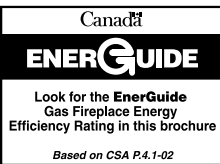

**FRAMING WITH SQUARE HORIZONTAL TERMINATIONS (SV4.5HT-2)

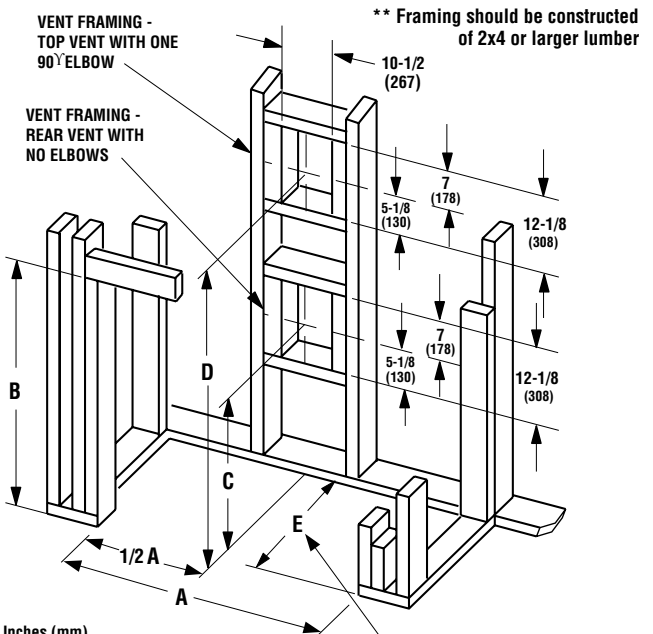

E is the required framing depth dimension when the finish material (drywall) thickness is 1/2 in. (13mm).

Vertical Venting Through the Ceiling:

Frame ceiling opening - Use a plumb line from the ceiling above the appliance to locate center of the vertical run. Cut and/or frame an opening, 10-1/2" x 10-1/2" (267 mm x 267 mm) inside dimensions, about this center mark (see Figure 25).

(Louvered Front Model Shown)

* CONCENTRIC FLUE FLUE - 4-1/2 (114)
COMBUSTION AIR - 7-1/2 (190)

* LMDV models have a top and rear vent
LMDVR models have only a rear vent
LMDVT models have only a top vent

**Note 1 - Collars protrude one inch on LMDVR-3328 model.

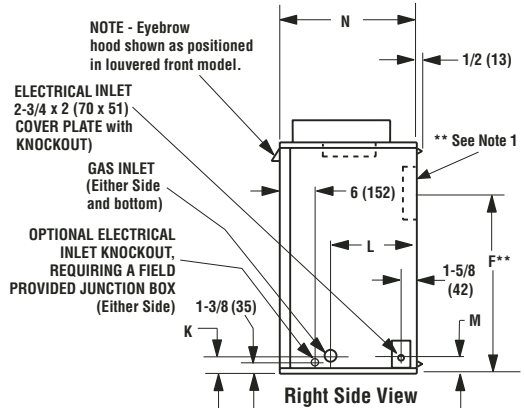

Model No.		A	B	C	D	E	**F	G	H	J	K	L	M	N
LMDVT-3328 LMDVR-3328	in.	33 1/8	30 1/8	17	27 1/2	33 1/8	19 5/8	21 1/2	10 3/4	6 13/16	3	8 11/32	2 3/4	13
	mm	841	765	432	699	841	498	546	273	173	76	212	70	330
LMDV-3530	in.	35 1/8	32 1/8	19	29 1/2	35 1/8	21 11/16	24 7/8	12 7/16	9	3	9	3	16
	mm	892	816	483	749	892	551	632	316	220	76	220	76	406
LMDV-4035	in.	40 1/8	37 1/8	24	34 1/2	40 1/8	26 11/16	29 7/8	14 15/16	9	3	9	3	16
	mm	1019	943	610	876	1019	678	759	379	220	76	220	76	406

Figure 14

FIREPLACE FRAMING SPECIFICATIONS

Note-
Venting requirements for rear vent applications in corner installations -
• The horizontal vent length "a" to "b" must not exceed 28 inches (711 mm).

LMDVT-3328 and LMDVR-3328 Models -
Dimension A to F occur when one 45 degree elbow is connected directly to the appliance collar.

LMDVT-3530 and LMDVR-4035 Models -
Dimension D and F occur when one 45 degree elbow is connected directly to the appliance collar.

Model No.		A	B	C	D	E	F
LMDVT-3328	in.	33 1/8	48 1/2	34 5/16	17 3/16	24 1/4	5
LMDVR-3328	mm	841	1232	872	437	616	127
LMDV-3530	in.	35 1/8	57 1/2	40 5/8	19 3/16	28 3/4	6 1/8
	mm	892	1461	1032	487	730	156
LMDV-4035	in.	40 1/8	6 13/16	43 11/32	19 3/16	30 11/16	7 7/8
	mm	1019	1554	1101	487	779	200

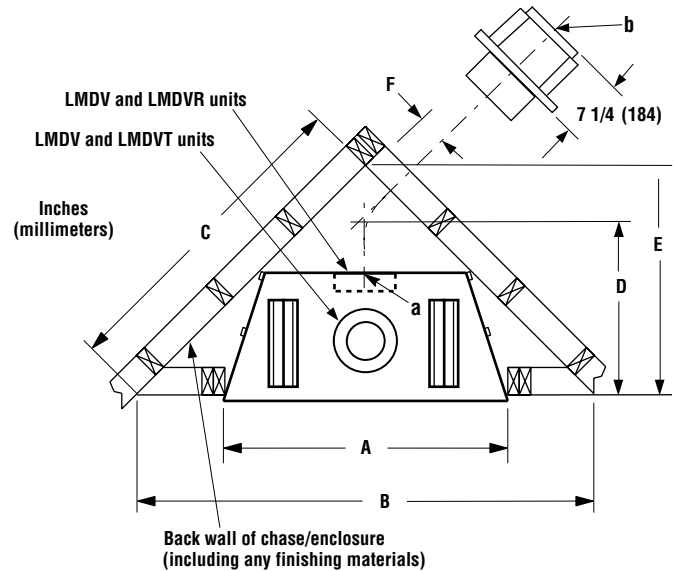

Figure 15 - Corner Framing with Square Termination (SV4.5HT-2)

Proper Sizing of Gas Line

Properly size and route the gas supply line from the supply regulator to the area where the appliance is to be installed per requirements outlined in the National Fuel Gas Code, NFPA 54 - latest edition (USA) or B149 - latest edition (Canada).

Never use galvanized or plastic pipe. Refer to **Table 9** for proper sizing of the gas supply line, if black iron pipe is being used. Gas lines must be routed, constructed and made of materials that are in strict accordance with local codes and regulations. We recommend that a qualified individual such as a plumber or gas fitter be hired to correctly size and route the gas supply line to the appliance. Installing a gas supply line from the fuel supply to the appliance involves numerous considerations of materials, protection, sizing, locations, controls, pressure, sediment, and more. Certainly no one unfamiliar and unqualified should attempt sizing or installing gas piping.

Schedule 40 Black Iron Pipe Inside Diameter (Inches)		
Schedule 40 Pipe Length (feet)	Natural Gas	Propane Gas
0-10	1/2	3/8
10-40	1/2	1/2
40-100	1/2	1/2
100-150	3/4	1/2
150-200	3/4	1/2

Table 9

Notes:

- All appliances are factory-equipped with a flexible gas line connector and 1/2 inch shutoff valve (see **Figure 48** on **Page 24**).
- See **Massachusetts Requirements** on **Page 4** for additional requirements for installations in the state of Massachusetts in the USA.
- The gas supply line should Not be connected to the appliance until **Step 6 (Page 24)**.

- A pipe joint compound rated for gas should be used on the threaded joints. **Ensure** propane resistant compounds are used in propane applications. Be very careful that the pipe compound does not get inside the pipe.
- It is recommended to install a sediment trap in the supply line as close as possible to the appliance (see **Figure 48**). Appliances using Propane should have a sediment trap at the base of the tank.
- Check with local building official for local code requirements (i.e. are below grade penetrations of the gas line allowed?, etc).

IMPORTANT: If propane is used, be aware that if tank size is too small (i.e. under 100-lbs, if this is the only gas appliance in the dwelling. Ref. NPFA 58), there may be loss of pressure, resulting in insufficient fuel delivery (which can result in sooting, severe delayed ignition or other malfunctions). Any damage resulting from an improper installation, such as this, is not covered under the limited warranty.

NOTE: DIAGRAMS & ILLUSTRATIONS ARE NOT TO SCALE.

Step 3. INSTALL THE VENT SYSTEM

General Information

These instructions should be used as a guideline and do not supersede local codes in any way. Install vent according to local codes, these instructions, the current National Fuel Gas Code (ANSI-Z223.1) in the USA or the current standards of CAN/CGA-B149.1 and -B149.2 in Canada.

Use only approved venting components. See *Approved Vent Components on Page 2.*

These fireplaces must be vented directly to the outside.

The vent system may not service multiple appliances, and must never be connected to a flue serving a solid fuel burning appliance. The vent pipe is tested to be run inside an enclosing wall (such as a chase). There is no requirement for inspection openings in the enclosing wall at any of the joints in the vent pipe.

Preparing the Appliance Vent Collar on LMDV-3530/4035 Series (Combined Top and Rear Vent) Models.

Each of the unit's two vent collars are sealed with a cover plate and a seal plate and gasket. The cover, and seal plate and gasket must be removed from the vent collar being used. Refer to *Figure 16* for top vent usage and *Figure 17* for rear, and the following steps to prepare the appropriate collar for use.

From the vent collar being used, remove the four screws securing the vent seal plate and gasket. Remove and discard the seal plate and gasket.

When the top vent collar is being used, from inside the firebox, loosen the two screws in the keyhole slots of the cover plate and remove the remaining two cover plate securing screws. Remove and discard the cover plate. Reinstall and securely tighten all four screws.

! WARNING

Failure to reinstall and securely tighten cover plate screws could result in leakage of flue products into the living space. Vent cover plate and vent seal plate must remain securely installed on unused vent collar. Failure to do so could result in leakage of flue products into living space.

When the rear vent collar is being used, from inside the firebox, remove the two screws securing the lintel to the rear wall of the firebox, then remove the lintel. Remove the four cover plate securing screws.

Remove and discard the cover plate. Reinstall and securely tighten all four cover plate screws. Re-secure the lintel to the rear wall of the firebox.

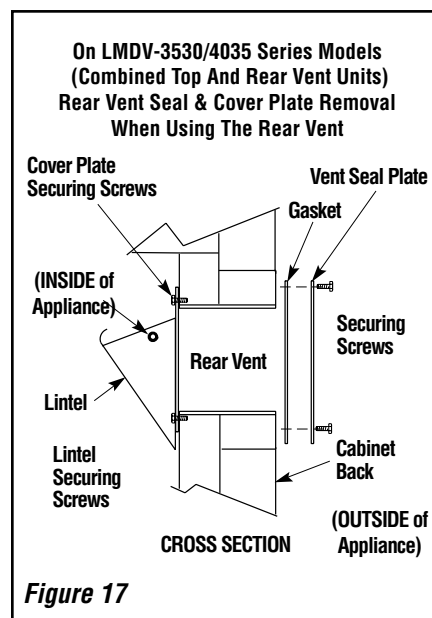
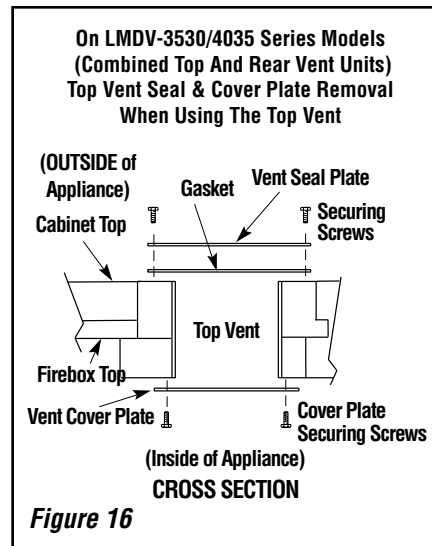

Installation of Vent Restrictor

A vent restrictor may be needed with this appliance, install vent restrictor (provided) in the appliance top flue outlet as shown in *Figure 18* (LMDV-3328, LMDV-3530 and LMDV-4035) or rear flue outlet as shown in *Figure 19* (LMDV-3328, LMDV-3530 and LMDV-4035). It is held in place by friction, only.

Vent Restrictor Installation (Top Vent)

A vent restrictor may be needed when vertically terminating the vent system above the roof (when using the appliance top vent), install vent restrictor in the top vent of the fireplace outlet on LMDV-3530/4035 and LMDVT-3328 series models. If needed, install the restrictor orientated as shown, either from inside or outside the unit, in the inner fireplace collar.

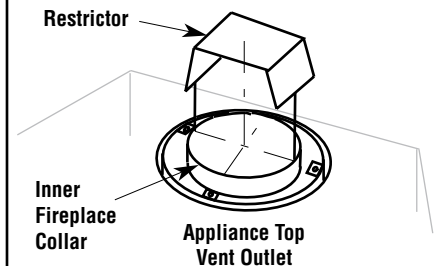

Figure 18

VENT RESTRICTOR INSTALLATION (REAR VENT)

A vent restrictor may be needed when horizontally terminating the vent system from the rear of the appliance (when using the appliance rear vent), install vent restrictor in the rear vent of the fireplace outlet on LMDV(R)-3328/3530/4035 series models, in any installation that has a vertical vent run in excess of three feet (0.914 meters).

If needed, install the restrictor orientated as shown, either from inside or outside the unit, in the inner fireplace collar

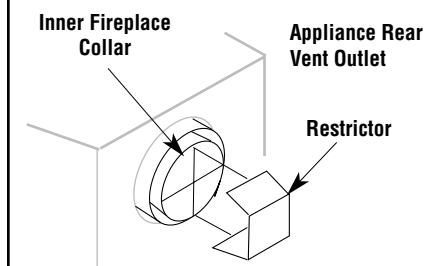

Figure 19

Select Venting System - Horizontal or Vertical

With the appliance secured in framing, determine vent routing and identify the exterior termination location. The following sections describe vertical (roof) and horizontal (exterior wall) vent applications. Refer to the section relating to your installation. A list of approved venting components is shown on *Pages 31 and 32.*

VERTICAL TERMINATION SYSTEMS (ROOF)

See Figure 20 on Page 12 and Figures 28-32 on Pages 15 and 16 and their associated Vertical Vent Tables which illustrate the various vertical venting configurations that are possible for use with these appliances. **Secure Vent** pipe applications are shown in these Figures; **Secure Flex** pipe may also be used. A Vertical Vent Table summarizes each system's minimum and maximum vertical and horizontal length values that can be used to design and install the vent components in a variety of applications.

Both these vertical vent systems terminate through the roof. The minimum vent height above the roof and/or adjacent walls is specified in ANSI Z223.1-(latest edition) (In Canada, the current CAN-1 B149 installation code) by major building codes. Always consult your local codes for specific requirements. A general guide to follow is the Gas Vent Rule (refer to Figure 5 on Page 5).

Vertical (Straight) Installation

Determine the number of straight vent sections required. 4-1/2" (114 mm), 10-1/2" (267 mm), 22-1/2" (572 mm), 34-1/2" (876 mm) and 46-1/2" (1181 mm) net section lengths are available (see Table 11 and Page 31 - Item 3). Plan the vent lengths so that a joint does not occur at the intersection of ceiling or roof joists. Refer to the Vent Section Length Chart.

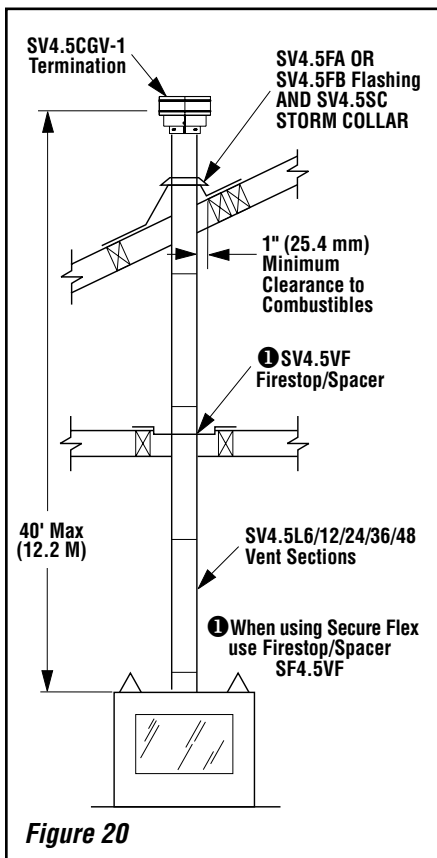

Figure 20

VENT SECTION LENGTH CHART							TOTAL QTY
Nominal Section Length (inches)	6	12	24	36	48		
Net Section Length (inches)	4 ½	10 ½	22 ½	34 ½	46 ½		
Height of Vent	Number of Vent Sections						
*inches	feet						
4.5	0.375	1	0	0	0	0	1
9	0.75	2	0	0	0	0	2
10.5	0.875	0	1	0	0	0	1
15	1.25	1	1	0	0	0	2
19.5	1.625	2	1	0	0	0	3
21	1.75	0	2	0	0	0	2
22.5	1.875	0	0	1	0	0	1
25.5	2.125	1	2	0	0	0	3
31.5	2.625	0	3	0	0	0	3
34.5	2.875	0	0	0	1	0	1
37.5	3.125	1	1	1	0	0	3
43.5	3.625	0	2	1	0	0	3
45	3.75	0	0	2	0	0	2
46.5	3.875	0	0	0	0	1	1
49.5	4.125	1	0	2	0	0	3
51	4.25	1	0	0	0	1	2
55.5	4.625	0	1	2	0	0	3
57	4.75	0	0	1	1	0	2
66	5.25	0	2	2	0	0	4
67.5	5.625	0	0	3	0	0	3
69	5.75	0	0	0	2	0	2
72	6	1	0	3	0	0	4
73.5	6.125	1	0	0	2	0	3
79.5	6.625	0	1	0	2	0	3
81	6.75	0	0	0	1	1	2
90	7.5	0	2	1	0	1	4
91.5	7.625	0	0	2	0	1	3
93	7.75	0	0	0	0	2	2
96	8	1	0	1	2	0	4
97.5	8.125	1	0	0	0	2	3
102	8.5	2	0	0	0	2	4
103.5	8.625	0	0	0	3	0	3
108	9	1	0	0	3	0	4
114	9.5	0	2	0	0	2	4
117	9.75	1	0	5	0	0	6
118.5	9.875	1	1	0	3	0	5
126	10.5	0	0	1	3	0	4
130.5	10.875	1	0	1	3	0	5
135	11.25	0	0	6	0	0	6
138	11.5	0	0	0	4	0	4
139.5	11.625	0	0	0	0	3	3
142.5	11.875	1	0	0	4	0	5

Table 10a

* Convert inches into metric equivalent measure, as follows:

Millimeters (mm) = Inches x 25.4
Centimeters (cm) = Inches x 2.54
Meters (M) = Inches x .0254

VENT SECTION LENGTH CHART							TOTAL QTY
Nominal Section Length (inches)	6	12	24	36	48		
Net Section Length (inches)	4 ½	10 ½	22 ½	34 ½	46 ½		
Height of Vent	Number of Vent Sections						
*inches	feet						
144	12	1	0	0	0	3	4
150	12.5	0	1	0	0	3	4
154.5	12.875	1	1	0	0	3	5
160.5	13.375	0	2	0	0	3	5
172.5	14.375	0	0	0	5	0	5
177	14.75	1	0	0	5	0	6
183	15.25	0	1	0	5	0	6
186	15.5	0	0	0	0	4	4
190.5	15.875	1	0	0	0	4	5
196.5	16.375	0	1	0	0	4	5
205.5	17.125	0	1	1	5	0	7
207	17.25	0	0	0	6	0	6
211.5	17.625	1	0	0	6	0	7
217.5	18.125	0	1	0	6	0	7
229.5	19.125	0	0	1	6	0	7
232.5	19.375	0	0	0	0	5	5
237	19.75	1	0	0	0	5	6
241.5	20.125	0	0	0	7	0	7
246	20.5	1	0	0	7	0	8
252	21	0	1	0	7	0	8
264	22	0	0	1	7	0	8
276	23	0	0	0	8	0	8
279	23.25	0	0	0	0	6	6
280.5	23.375	1	0	0	8	0	9
283.5	23.625	1	0	0	0	6	7
289.5	24.125	0	1	0	0	6	7
301.5	25.125	0	0	1	0	6	7
310.5	25.875	0	0	0	9	0	9
315	26.5	1	0	0	9	0	10
325.5	27.125	0	0	0	0	7	7
330	27.5	1	0	0	0	7	8
336	28	0	1	0	0	7	8
345	28.75	0	0	0	10	0	10
349.5	29.125	1	0	0	10	0	11
372	31	0	0	0	0	8	8
376.5	31.375	1	0	0	0	8	9
379.5	31.625	0	0	0	11	0	11
418.5	34.875	0	0	0	0	9	9
423	35.25	1	0	0	0	9	10
465	38.75	0	0	0	0	10	10

Table 10b

Effective Vent Length	
Model	Effective Length
SV4.5L6	4-1/2"
SV4.5L12	10-1/2"
SV4.5L24	22-1/2"
SV4.5L36	34-1/2"
SV4.5L48	46-1/2"

Table 11

NOTE: DIAGRAMS & ILLUSTRATIONS ARE NOT TO SCALE.

Vertical (Offset) Installation

Analyze the vent routing and determine the quantities of vent sections and number of elbows required. Refer to **Vertical Vent Figures and Tables on Pages 15 and 16** to select the type of vertical installation desired. Vent sections are available in net lengths of 4-1/2" (114 mm), 10-1/2" (267 mm), 22-1/2" (572 mm), 34-1/2" (876 mm) and 46-1/2" (1181 mm). Refer to the **Vent Section Length Chart on Page 12** for an aid in selecting length combinations. Elbows are available in 90° and 45° configurations. Refer to **Figure 24 on Page 14** for the SV4.5E45 and SV4.5E90 elbow dimensional specifications.

Where required, a **telescopic vent section (SV4.5LA)** may be used to provide the installer with an option in installing in tight and confined spaces or where the vent run made up of fixed length pieces develops a joint in a undesirable location, or will not build up to the required length. The SV4.5LA Telescopic Vent Section has an effective length of from 1-1/2" (38 mm) to 7-1/2" (191 mm). The SV4.5LA is fitted with a locking inclined channel end (identical to a normal vent section component) and a plain end with 3 pilot holes. Slip the plain end over the locking channel end of a standard SV4.5 vent component the required distance and secure with three screws.

Maintain a minimum 1" (25 mm) clearance to combustible materials for all vertical elements. Clearances for all horizontal elements are 3" (76 mm) on top, 1" (25 mm) on sides and 1" (25 mm) on the bottom.

A. Frame ceiling opening - Use a plumb line from the ceiling above the appliance to locate center of the vertical run. Cut and/or frame an opening, 10-1/2" x 10-1/2" (267mm x 267mm) inside dimensions, about this center mark (**Figure 21**).

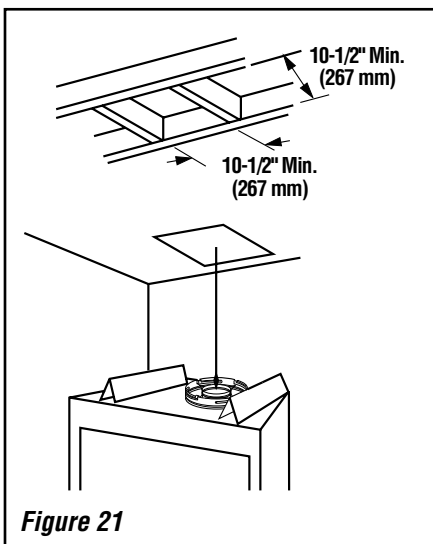

B. Attach vent components to appliance - **Secure Vent SV4.5** direct vent system components are unitized concentric pipe components featuring positive twist lock connections (*see Figure 22*).

All of the appliances covered in this document are fitted with collars having locking inclined channels. The dimpled end of the vent components fit over the appliance collar to create the positive twist lock connection.

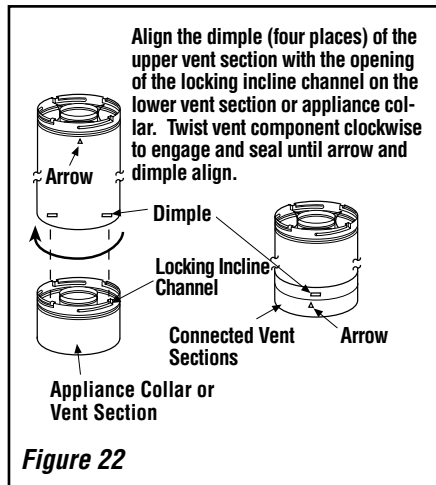

To attach a vent component to the appliance collar, align the dimpled end over the collar, adjusting the radial alignment until the four locking dimples are aligned with the inlet of the four inclined channels on the collar (*refer to Figure 22*). Push the vent component against the collar until it fully engages, then twist the component clockwise, running the dimples down and along the incline channels until they seat at the end of the channels. The unitized design of the **Secure Vent** components will engage and seal both the inner and outer pipe without the need for sealant or screws. If desired, a #6 x 1/2" screw may be used at the joint, but is not required as the pipe will securely lock when twisted.

Note: An elbow may also be attached to the appliance collar. Attach in the same manner as you would a vent section.

C. Attach vent components to each other - Other vent sections may be added to the previously installed section in accordance with the requirements of the vertical vent Figures and Tables.

To add another vent component to a length of vent run, align the dimpled end over the inclined channel end of the previously installed section, adjusting the radial alignment until the four locking dimples are aligned with the inlets of the four incline channels of the previous section.

Push the vent component against the previous section until it fully engages, then twist the component clockwise running the dimples down and along the incline channels until they seat at the end of the channels. **This seating position is indicated by the alignment of the arrow and dimple as shown in Figure 22.**

D. Install firestop/spacer at ceiling - When using Secure Vent, use SV4.5VF firestop/spacer at ceiling joists; when using Secure Flex, use SF4.5VF firestop/spacer. If there is living space above the ceiling level, the firestop/spacer must be installed on the bottom side of the ceiling. If attic space is above the ceiling, the firestop/spacer must be installed on the top side of the joist. Route the vent sections through the framed opening and secure the firestop/spacer with 8d nails or other appropriate fasteners at each corner. **Remember to maintain 1" (25 mm) clearance to combustibles, framing members, and attic or ceiling insulation when running vertical chimney sections. Attic insulation shield (H3907) may be used to obtain the required clearances indicated here. See installation accessories Pages 31 & 32.**

E. Support the vertical vent run sections - **Note** - Proper venting support is very important. The weight of the vent must not be supported by the fireplace in any degree.

Support the vertical portion of the venting system every 8 feet (2.4m) above the fireplace vent outlet.

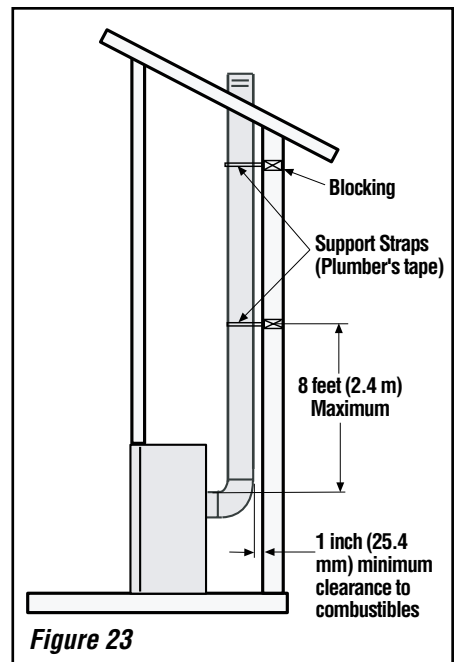

One method of support is by utilizing field provided support straps (conventional plumber's tape). Secure the plumber's tape to the framing members with nails or screws. Loop the tape around the vent, securing the ends of the tape to the framing. If desired, sheet metal screws #6 x 1/2" length may be used to secure the support straps to the vent pipe. Refer to **Figure 23**.

F. Change vent direction to horizontal/inclined run - At transition from or to a horizontal/inclined run, install the SV4.5E45 and SV4.5E90 elbows in the same manner as the straight vent sections. The elbows feature a twist section to allow them to be routed about the center axis of their initial collar section to align with the required direction of the next vent run element. **Twist elbow sections in a clockwise direction only so as to avoid the possibility of unlocking any of the previously connected vent sections.** See **Figure 24**.

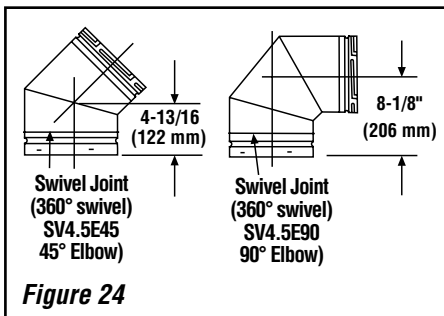

G. Continue installation of horizontal/inclined sections - Continue with the installation of the straight vent sections in horizontal/inclined run as described in **Step C**. Install support straps every 5 ft. (1.52 m) along horizontal/inclined vent runs using conventional plumber's tape. **See Page 17, Figure 33. It is very important that the horizontal/inclined run be maintained in a straight (no dips) and recommended to be in a slightly elevated plane, in a direction away from the fireplace of 1/4" rise per foot (20 mm per meter) which is ideal, though rise per foot run ratios that are smaller are acceptable all the way down to at or near level.** Use a carpenter's level to measure from a constant surface and adjust the support straps as necessary.

It is important to maintain the required clearances to combustibles: 1" (25 mm) at all sides for all vertical runs; and 3" (76 mm) at the top, 1" (25 mm) at sides, and 1" (25 mm) at the bottom for all horizontal/inclined runs.

H. Frame roof opening - Identify location for vent at the roof. Cut and/or frame opening per Roof Framing Chart (**Figure 25**).

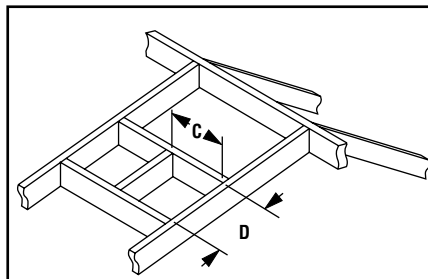

Framing Dimensions for Roof Inches (millimeters)		
Pitch	C	D
0/12	10-1/2 in. (267 mm)	10-1/2 in. (267 mm)
6/12	10-1/2 in. (267 mm)	12 in. (305 mm)
12/12	10-1/2 in. (267 mm)	17 3/4 in. (451 mm)

Figure 25- Roof Framing

I. Install the roof flashing - Extend the vent sections through the roof structure. Install the roof flashing over the vent section and position such that the vent column rises vertically (use carpenter's level) (**Figure 26**). Nail along perimeter to secure flashing or adjust roofing to overlap the flashing edges at top and sides only and trim where necessary. Seal the top and both sides of the flashing with waterproof caulking.

J. Install the storm collar - Install the storm collar, supplied with the flashing, over the vent/flashing joint. See **Figure 26**. Loosen the storm collar screw. Slide collar down until it meets the top of the flashing. Tighten the adjusting screw. Apply non-combustible caulking or mastic around the circumference of the joint to provide a water tight seal.

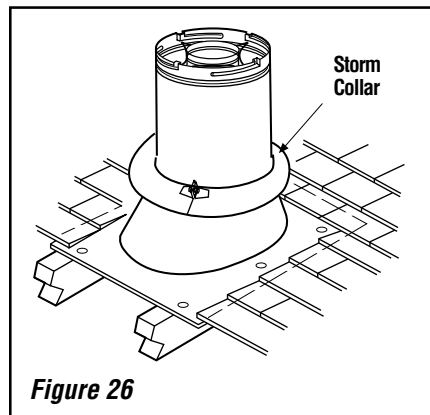

Figure 26

K. Install the vertical termination - The final step involves installation of the SV4.5CGV-1 Vertical Termination. Extend the vent sections to the height as shown in the "Vertical vent termination section" in **Figure 5 on Page 5**. The SV4.5CGV-1 Vertical Termination (**Figure 27**) can be installed in the exact same fashion as any other **Secure Vent** section. Align the termination over the end of the previously installed section, adjusting the radial alignment until the four locking dimples of the termination are aligned with the inlets of the four incline channels of the last vent section. Push the termination down until it fully engages, then twist the termination clockwise running the dimples down and along the incline channels until they are seated at the end of the channels.

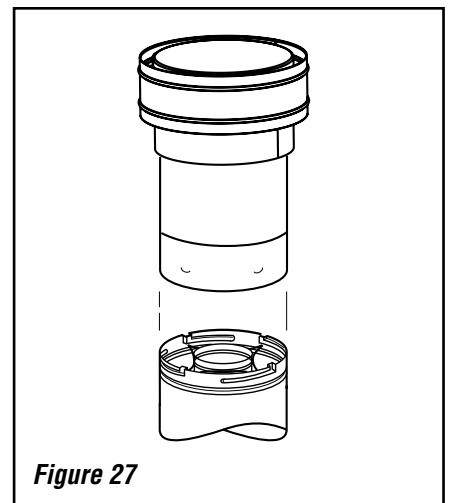

Figure 27

If the vent system extends more than 5 feet (1.5 m) above the roof flashing, stabilizers may be necessary. Additional screws may be used at section joints for added stability. Guide wires may be attached to the joint for additional support on multiple joint configurations.

VERTICAL VENT FIGURES/TABLES

Note: Secure Vent (rigid vent pipe) is shown in the Figures; Secure Flex (flexible vent pipe) may also be used.

⚠ WARNING

Under No Circumstances, May Separate Sections of Concentric Flexible Vent Pipe Be Joined Together.

Notes:

- It is very important that the horizontal/inclined run be maintained in a straight (no dips) and recommended to be in a slightly elevated plane, in a direction away from the fireplace of 1/4" rise per foot (20 mm per meter) which is ideal, though rise per foot run ratios that are smaller are acceptable all the way down to at or near level.
- SV4.5VF (Secure Vent), SF4.5VF (Secure Flex) firestop/spacer must be used anytime vent pipe passes through a combustible floor or ceiling. SV4.5HF (Secure Vent), SF4.5HF (Secure Flex) firestop/spacer must be used anytime vent pipe passes through a combustible wall.
- Two 45 degree elbows may be used in place of one 90 degree elbow. The same rise to run ratios, as shown in the venting Figures for 90 elbows, must be followed if 45 degree elbows are used.
- AN ELBOW IS ACCEPTABLE AS 1 FOOT OF VERTICAL RISE EXCEPT WHERE AN ELBOW IS THE ONLY VERTICAL COMPONENT IN THE SYSTEM (See Figure 37).

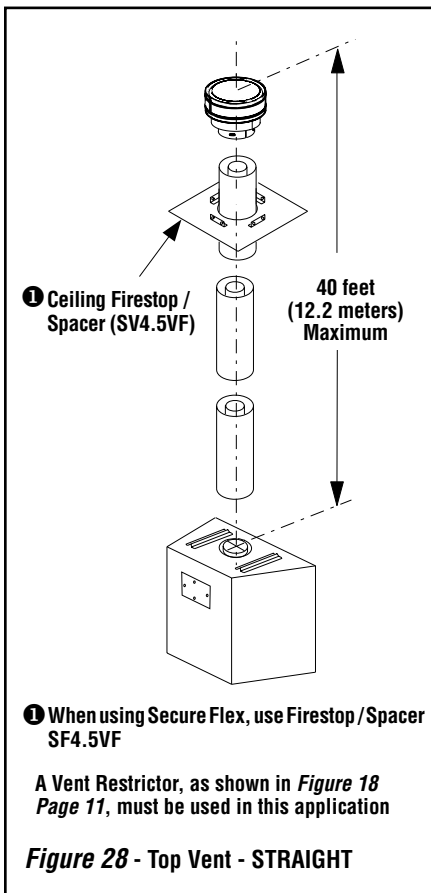

Table A			
H Maximum		V Minimum	
feet	(meter)	feet	(meter)
2	(0.610)	1	(0.305)
4	(1.219)	2	(0.610)
6	(1.829)	3	(0.914)
8	(2.438)	4	(1.219)
V + H = 40 feet (12.2 meters) Max. H = 8 feet (2.4 meters) Max. Ratio V to H ratio is 1:2			

Example: If 8 feet of (H) horizontal vent run is needed, then 4 feet minimum (V) vertical vent will be required.

This table shows a 1(V) to 2(H) ratio. For every 1 foot of (V) vertical, you are allowed 2 feet of (H) horizontal run, up to a maximum horizontal run of 8 feet.

1 When using Secure Flex, use Firestop / Spacer SF4.5VF.

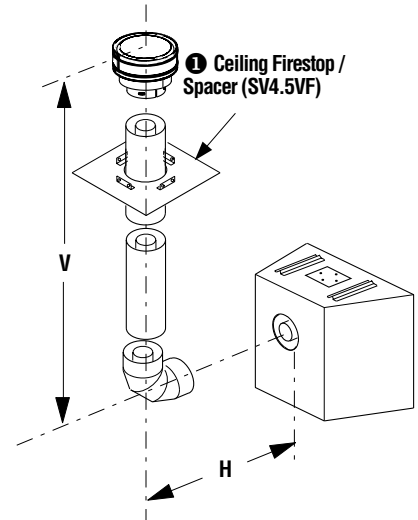
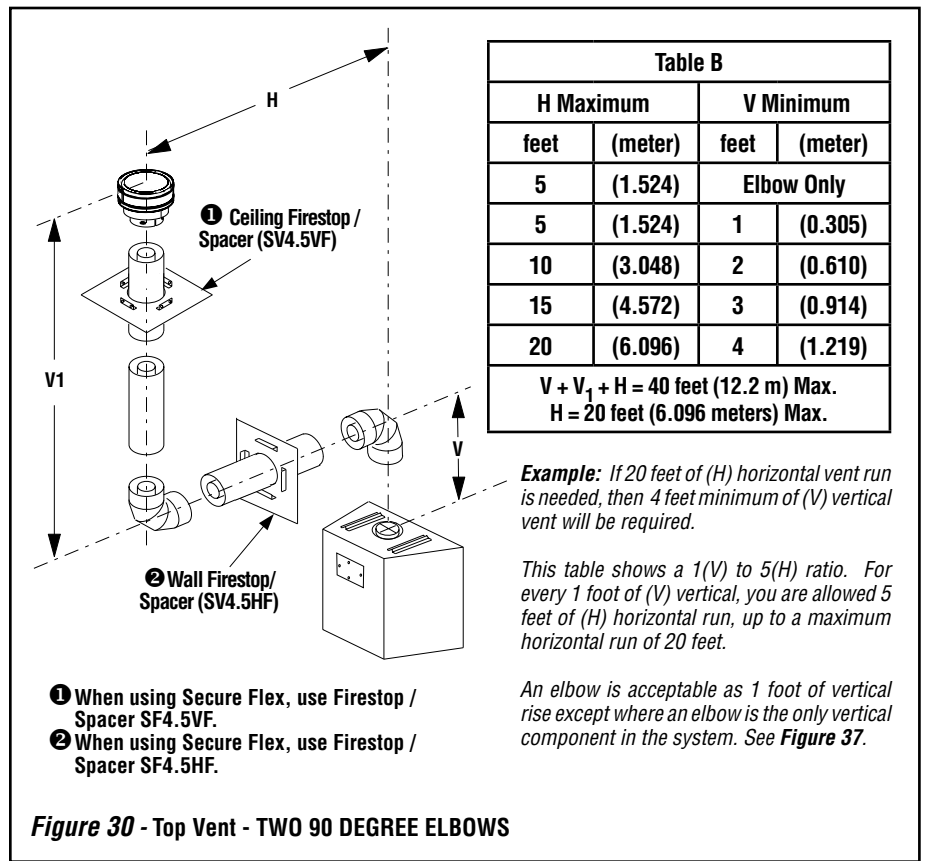

Figure 29 - Rear Vent - ONE 90 DEGREE ELBOW



VERTICAL VENT FIGURES/TABLES (CONTINUED)

Table C					
H+H ₁ Maximum		H Maximum		V Minimum	
feet	(meter)	feet	(meter)	feet	(meter)
5	(1.524)	2	(0.610)	1	(0.305)
10	(3.048)	4	(1.219)	2	(0.610)
15	(4.572)	6	(1.829)	3	(0.914)
20	(6.096)	8	(2.438)	4	(1.219)
V + V ₁ + H + H ₁ = 40 feet (12.2 m) Max H = 8 feet (2.438 meters) Max. H + H ₁ = 20 feet (6.096 meters) Max.					

- ① When using Secure Flex, use Firestop / Spacer SF4.5VF
- ② When using Secure Flex, use Firestop / Spacer SF4.5HF

Example: If 20 feet total (H+H₁) horizontal vent run is needed, then 4 feet minimum of (V) vertical vent will be required.

This table shows a 1(V) to 5(H) ratio. For every 1 foot of (V) vertical, you are allowed 5 feet of (H+H₁) horizontal run up to a maximum total horizontal run of 20 feet.

Figure 31 - Rear Vent - THREE ELBOWS

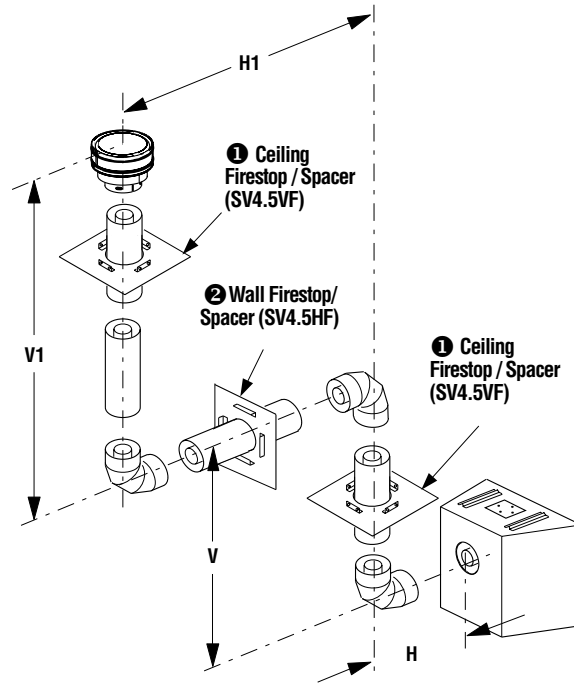

Table D			
H + H ₁ Maximum		V Minimum	
feet	(meter)	feet	(meter)
5	(1.524)	Elbow Only	
5	(1.524)	1	(0.305)
10	(3.048)	2	(0.610)
15	(4.572)	3	(0.914)
20	(6.096)	4	(1.219)
H + H ₁ = 20 feet (6.096 m) Max. V + V ₁ + H + H ₁ = 40 ft. (12.192 m) Max.			

Example: If 20 feet total (H+H₁) horizontal vent run is needed, then 4 feet minimum of (V) vertical vent will be required.

This table shows a 1(V) to 5(H) ratio. For every 1 foot of (V) vertical, you are allowed 5 feet of (H+H₁) horizontal run up to a maximum total horizontal run of 20 feet.

An elbow is acceptable as 1 foot of vertical rise except where an elbow is the only vertical component in the system. See Figure 37.

- ① When using Secure Flex, use Firestop / Spacer SF4.5VF
- ② When using Secure Flex, use Firestop / Spacer SF4.5HF

Figure 32 - Top Vent - THREE ELBOWS

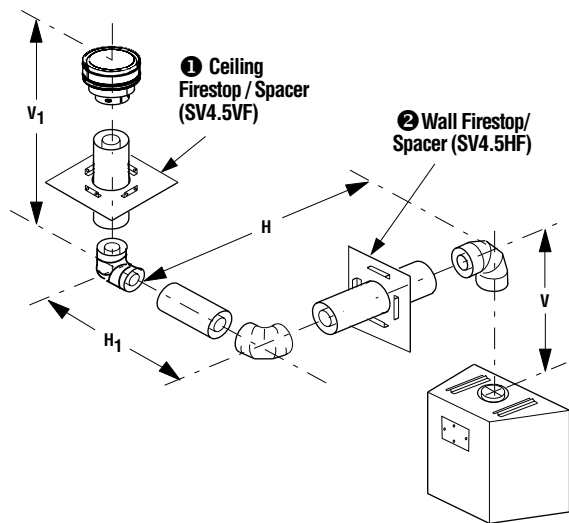

HORIZONTAL (OUTSIDE WALL) TERMINATION SYSTEM

Figure 33 on Page 17, and Figures 34 to 42 on Pages 18 to 21 and their associated Horizontal Vent Table illustrate the various horizontal venting configurations that are possible for use with these appliances. **Secure Vent** pipe applications are shown in these Figures; **Secure Flex** pipe may also be used. A Horizontal Vent Table summarizes each system's minimum and maximum vertical and horizontal length values that can be used to design and install the vent components in a variety of applications.

Both of these horizontal vent systems terminate through an outside wall. Building Codes limit or prohibit terminating in specific areas. Refer to Figure 7 on Page 6 for location guidelines.

Secure Vent SV4.5 direct vent system components are unitized concentric pipe components featuring positive twist lock connection, (refer to Figure 22 on Page 13). All of the appliances covered in this document are fitted with collars having locking inclined channels. The dimpled end of the vent components fit over the appliance collar to create the positive twist lock connection.

A. Plan the vent run -

Analyze the vent routing and determine the types and quantities of sections required 4-1/2" (114 mm), 10-1/2" (267 mm), 22-1/2" (572 mm), 34-1/2" (876 mm) and 46-1/2" (1181 mm) net section lengths are available. Plan the vent lengths so that a joint does not occur at the intersection of ceiling or roof joists. Make allowances for elbows as indicated in Figure 24.

Maintain a minimum 1" (25 mm) clearance to combustibles on the vertical sections. Clearances for the horizontal runs are; 3" (76 mm) on top, 1" (25 mm) on sides, and 1" (25 mm) at the bottom.

NOTE: DIAGRAMS & ILLUSTRATIONS ARE NOT TO SCALE.

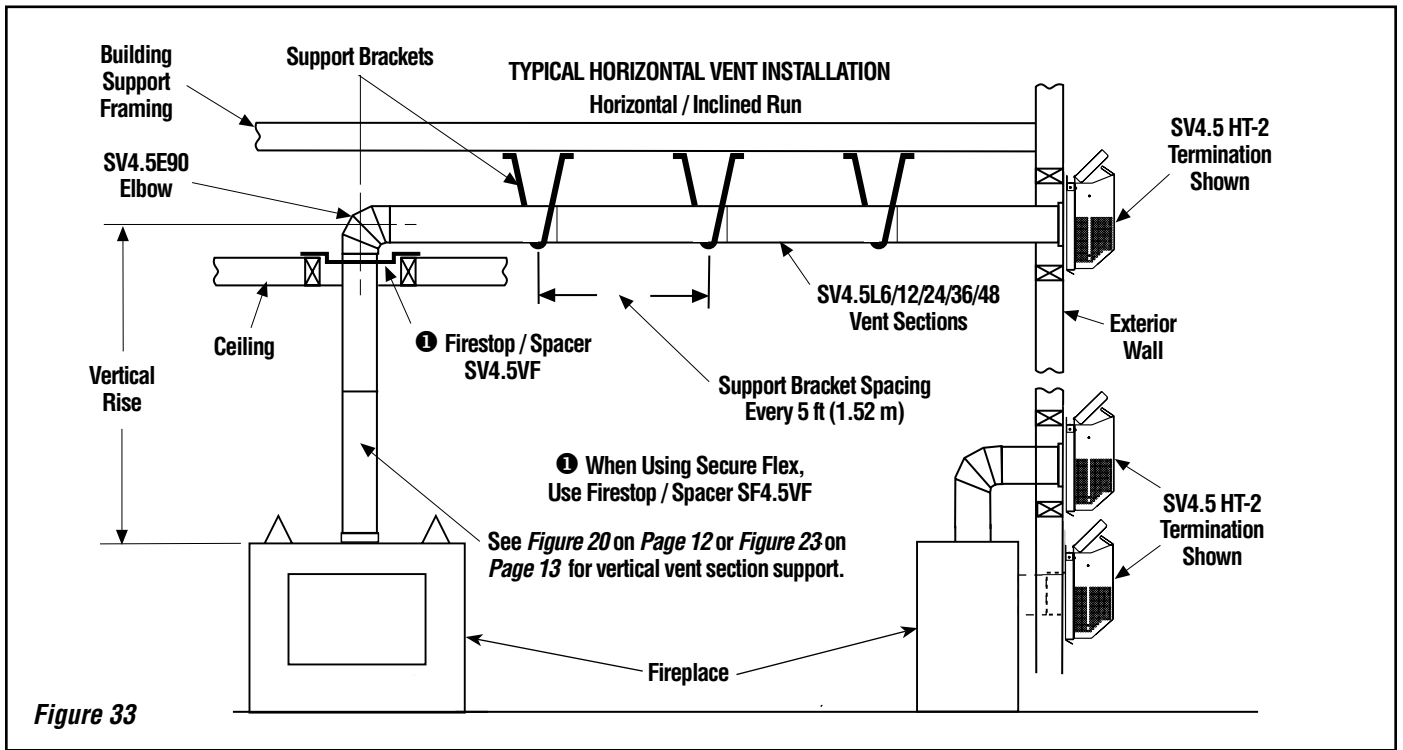

Figure 33

B. Frame exterior wall opening -

Locate the center of the vent outlet on the exterior wall according to the dimensions shown in **Figure 14 on Page 9**. Cut and/or frame an opening, 10-1/2" x 12 1/8" (267 mm x 308mm) inside dimensions, about this center.

C. Frame ceiling opening - If the vertical route is to penetrate a ceiling, use plumb line to locate the center above the appliance. Cut and/or frame an opening, 10-1/2" x 10-1/2" (267 mm x 267 mm) inside dimensions, about this center (refer to **Figure 21 on Page 13**).

D. Attach vent components to appliance - To attach a vent component to the appliance collar, align the dimpled end over the collar, adjusting the radial alignment until the four locking dimples are aligned with the inlets of the four incline channels on the collar (**see Figure 22 on Page 13**).

Push the vent component against the collar until it fully engages, then twist the component clockwise, running the dimples down and along the incline channels until they seat at the end of the channels.

The unitized design of the Secure Vent components will engage and seal both the inner and outer pipe elements with the same procedure. Sealant and securing screws are not required.

Note: An elbow may also be attached to the appliance collar. Attach in the same manner as you would a vent section.

E. Attach vent components to each other

- Other vent sections may be added to the previously installed section in accordance with the requirements of the vent tables. To add another vent component to a length of vent run, align the dimpled end of the component over the inclined channel end of the previously installed section, adjusting the radial alignment until the four locking dimples are aligned with the inlets of the four incline channels of the previous section.

Push the vent component against the previous section until it fully engages, then twist the component clockwise running the dimples down and along the incline channels until they seat at the end of the channels. **This seating position is indicated by the alignment of the arrow and dimple as shown in Figure 22 on Page 13.**

F. Install firestop/spacer at ceiling -

When using Secure Vent, use SV4.5VF firestop/spacer at ceiling joists; when using Secure Flex, use SF4.5VF firestop/spacer.

If there is living space above the ceiling level, the firestop/ spacer must be installed on the bottom side of the ceiling. If attic space is above the ceiling, the firestop/ spacer must be installed on the top side of the joist. Route the vent sections through the framed opening and secure the firestop/spacer with 8d nails or other appropriate fasteners at each corner.

Remember to maintain 1" (25 mm) clearance to combustibles, framing members, and attic or ceiling insulation when running vertical chimney sections.

G. Support the vertical run sections - See Section E on Page 13.

H. Change vent direction - At transition from or to a horizontal/inclined run, install the SV4.5E45 and SV4.5E90 elbows in the same manner as the straight vent sections. The elbows feature a twist section to allow them to be routed about the center axis of their initial collar section to align with the required direction of the next vent run element. **Twist elbow sections in a clockwise direction only so as to avoid the possibility of unlocking any of the previously connected vent sections.** See **Figure 22 on Page 13**.

I. Continue installation of horizontal/inclined sections - Continue with the installation of the straight vent sections in horizontal/inclined run as described in **Step E**. Install support straps every 5 ft. (1.52 m) along horizontal/inclined vent runs using conventional plumber's tape.

See **Figure 33**. **It is very important that the horizontal/inclined run be maintained in a straight (no dips)** and recommended to be in a slightly elevated plane, in a direction away from the fireplace of 1/4" rise per foot (20 mm per meter) which is ideal, though rise per foot run ratios that are smaller are acceptable all the way down to at or near level.

It is important to maintain the required clearances to combustibles: 1" (25 mm) at all sides for all vertical runs; and 3" (76 mm) at the top, 1" (25 mm) at sides, and 1" (25 mm) at the bottom for all horizontal/inclined runs.

HORIZONTAL VENT FIGURES/TABLES

Notes:

- **Secure Vent** components (rigid vent pipe and terminal) are shown in the Figures; **Secure Flex** components (flexible vent pipe and terminal) may also be used.
- Two 45 degree elbows may be used in place of one 90 degree elbow. The same rise to run ratios, as shown in the venting Figures for 90 elbows, must be followed if 45 degree elbows are used.
- SV4.5VF (**Secure Vent**), SF4.5VF (**Secure Flex**) firestop/spacer must be used anytime vent pipe passes through a combustible floor or ceiling. SV4.5HF (**Secure Vent**), SF4.5HF (**Secure Flex**) firestop/spacer must be used anytime vent pipe passes through a combustible wall.
- **It is very important that the horizontal/inclined run be maintained in a straight (no dips) and recommended to be in a slightly elevated plane, in a direction away from the fireplace of 1/4" rise per foot (20 mm per meter) which is ideal, though rise per foot run ratios that are smaller are acceptable all the way down to at or near level.**
- The tables show a 1(V) to 5(H) ratio up to a maximum horizontal run of 20 feet except for installations where an elbow is the only vertical section in the system (see **Figure 37**).
- **AN ELBOW IS ACCEPTABLE AS 1 FOOT OF VERTICAL RISE EXCEPT WHERE AN ELBOW IS THE ONLY VERTICAL COMPONENT IN THE SYSTEM. See Figure 37.**

Venting Components Required for Various Exterior Wall Thicknesses, when using Square Termination Kit (SV4.5HT-2)	
Vent Components Required	Exterior Wall Thickness - inches (mm)
Termination Kit Only	6 to 9-1/4 (152 to 235)
Termination Kit and 6 In. Vent Section (SV4.5L6)	10-3/4 to 14 (273 to 356)
Termination Kit and 12 in. Vent Section (SV4.5L12)	16-3/4 to 20 (426 to 508)
Termination Kit and Telescopic Section (SV4.5L12)	11-3/4 to 20 (299 to 508)

Table 12 Note: See Figure 35 showing wall thickness range when using SV4.5HT-2 termination kit only.

See Table 12 as an aid in venting component selection for a particular range of exterior wall thicknesses.

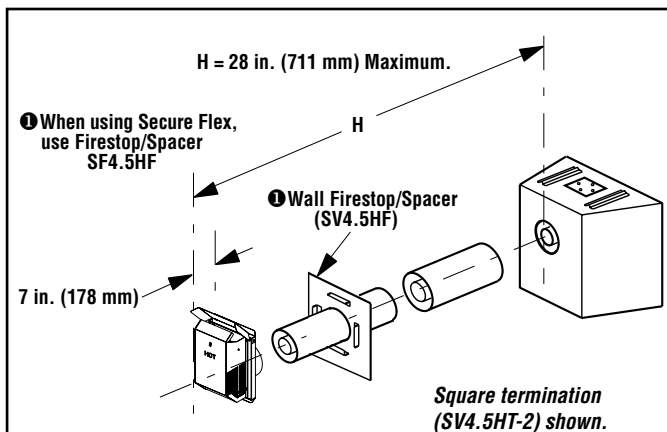

Figure 36 - Rear Vent - NO ELBOWS - Square Horizontal Termination (SV4.5HT-2)

! WARNING

Under no circumstances, may separate sections of concentric flexible vent pipe be joined together.

Table F			
H Maximum		V Minimum	
feet	(meter)	feet	(meter)
3	(0.914)	Elbow Only	

Square termination (SV4.5HT-2) shown.

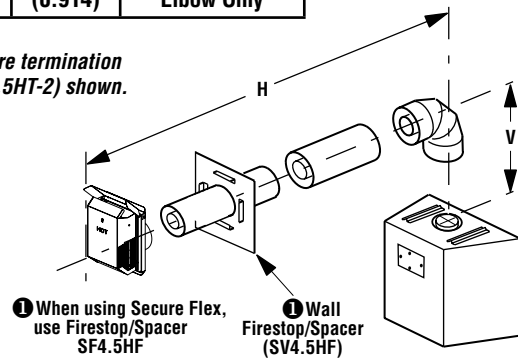

See Table 12 as an aid in venting component selection for a particular range of exterior wall thicknesses.

Figure 37 - Top Vent - ONE 90 DEGREE ELBOW - ELBOW CONNECTION AT APPLIANCE

Table G			
H Maximum		V Minimum	
feet	(meter)	feet	(meter)
5	(1.524)	1	(0.305)
10	(3.048)	2	(0.610)
15	(4.572)	3	(0.914)
20	(6.096)	4	(1.219)
V + H = 40 feet (12.2 m) Max.			
H = 20 ft. (6.096 m) Max.			

Example: If 20 feet of (H) horizontal vent run is needed, then 4 feet minimum of (V) vertical vent will be required.

This table shows a 1(V) to 5(H) ratio. For every 1 foot of vertical, you are allowed 5 feet of (H) horizontal run up to a maximum (H) horizontal run of 20 feet.

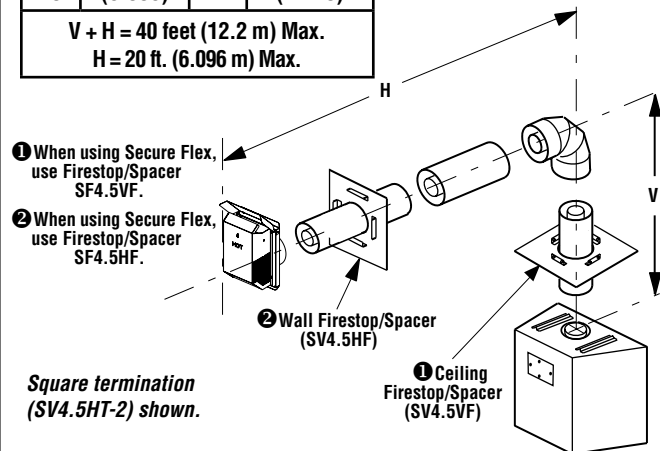

See Table 12 as an aid in venting component selection for a particular range of exterior wall thicknesses.

Figure 38 - Top Vent - ONE 90 DEGREE ELBOW - ELBOW CONNECTION NOT DIRECTLY AT APPLIANCE

HORIZONTAL VENT FIGURES / TABLES (CONTINUED)

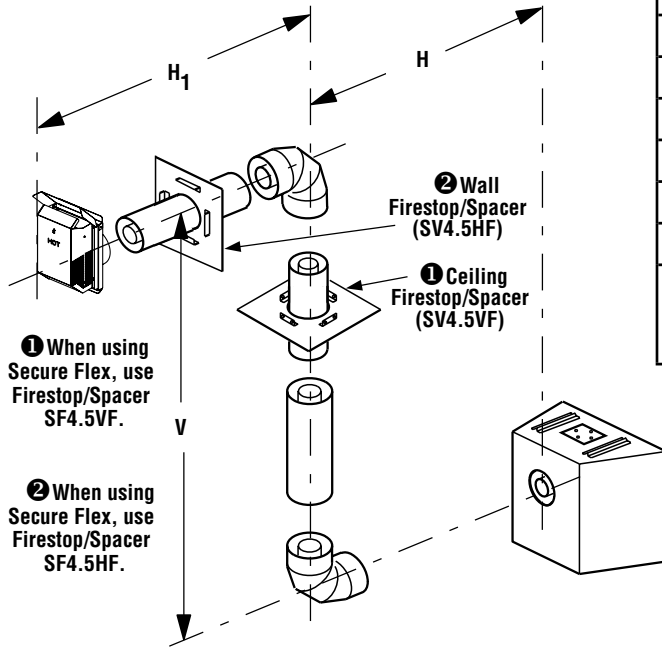

Square termination (SV4.5HT-2) shown.

Figure 39 - Rear Vent - TWO 90 DEGREE ELBOWS

H+H ₁ Maximum		H Maximum		V Minimum	
feet	(meter)	feet	(meter)	feet	(meter)
5	(1.524)	2	(0.610)	1	(0.305)
10	(3.048)	4	(1.219)	2	(0.610)
15	(4.572)	6	(1.829)	3	(0.914)
20	(6.096)	8	(2.438)	4	(1.219)

V + H + H₁ = 40 feet (12.2 m) Max
 H = 8 feet (2.438 meters) Max.
 H + H₁ = 20 feet (6.096 meters) Max.

Example: If 20 feet of (H + H₁) horizontal vent run is needed, then 4 feet minimum of (V) vertical vent will be required.

This table shows a 1(V) to 5(H) ratio. For every 1 foot of (V) vertical, you are allowed 5 feet of (H + H₁) horizontal run, up to a maximum horizontal run of 20 feet.

See Table 12 on Page 19 as an aid in venting component selection for a particular range of exterior wall thicknesses.

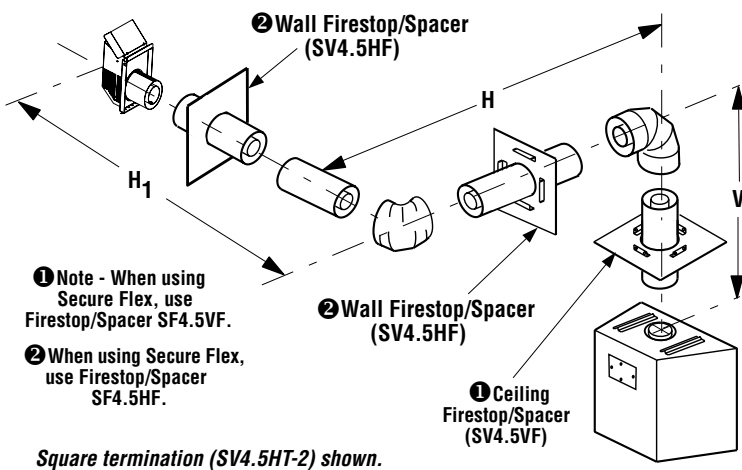

Square termination (SV4.5HT-2) shown.

See Table 12 on Page 19 as an aid in venting component selection for a particular range of exterior wall thicknesses.

Figure 40 - Top Vent - TWO 90 DEGREE ELBOWS

H + H ₁ Maximum		V Minimum	
feet	(meter)	feet	(meter)
3	(0.914)	Elbow Only	
5	(1.524)	1	(0.305)
10	(3.048)	2	(0.610)
15	(4.572)	3	(0.914)
20	(6.096)	4	(1.219)

V + H + H₁ = 40 feet (12.2 m) Max.
 H + H₁ = 20 ft. (6.096 m) Max.

Example: If 20 feet of (H + H₁) horizontal vent run is needed, then 4 feet minimum of (V) vertical vent will be required.

This table shows a 1(V) to 5(H) ratio. For every 1 foot of (V) vertical, you are allowed 5 feet of (H + H₁) horizontal run, up to a maximum horizontal run of 20 feet.

An elbow is acceptable as 1 foot of vertical rise except where an elbow is the only vertical component in the system. See Figure 37.

HORIZONTAL VENT FIGURES / TABLES (CONTINUED)

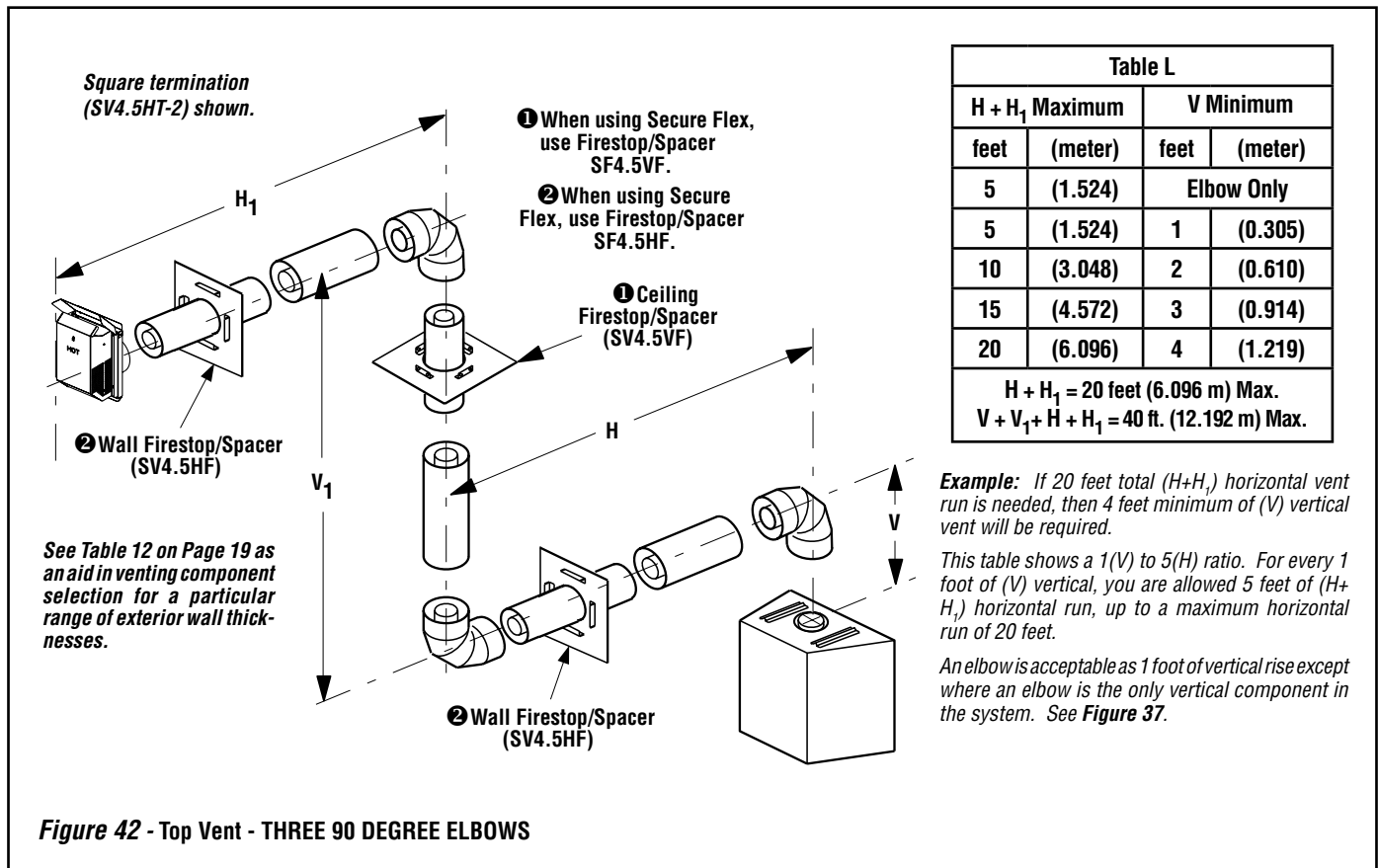
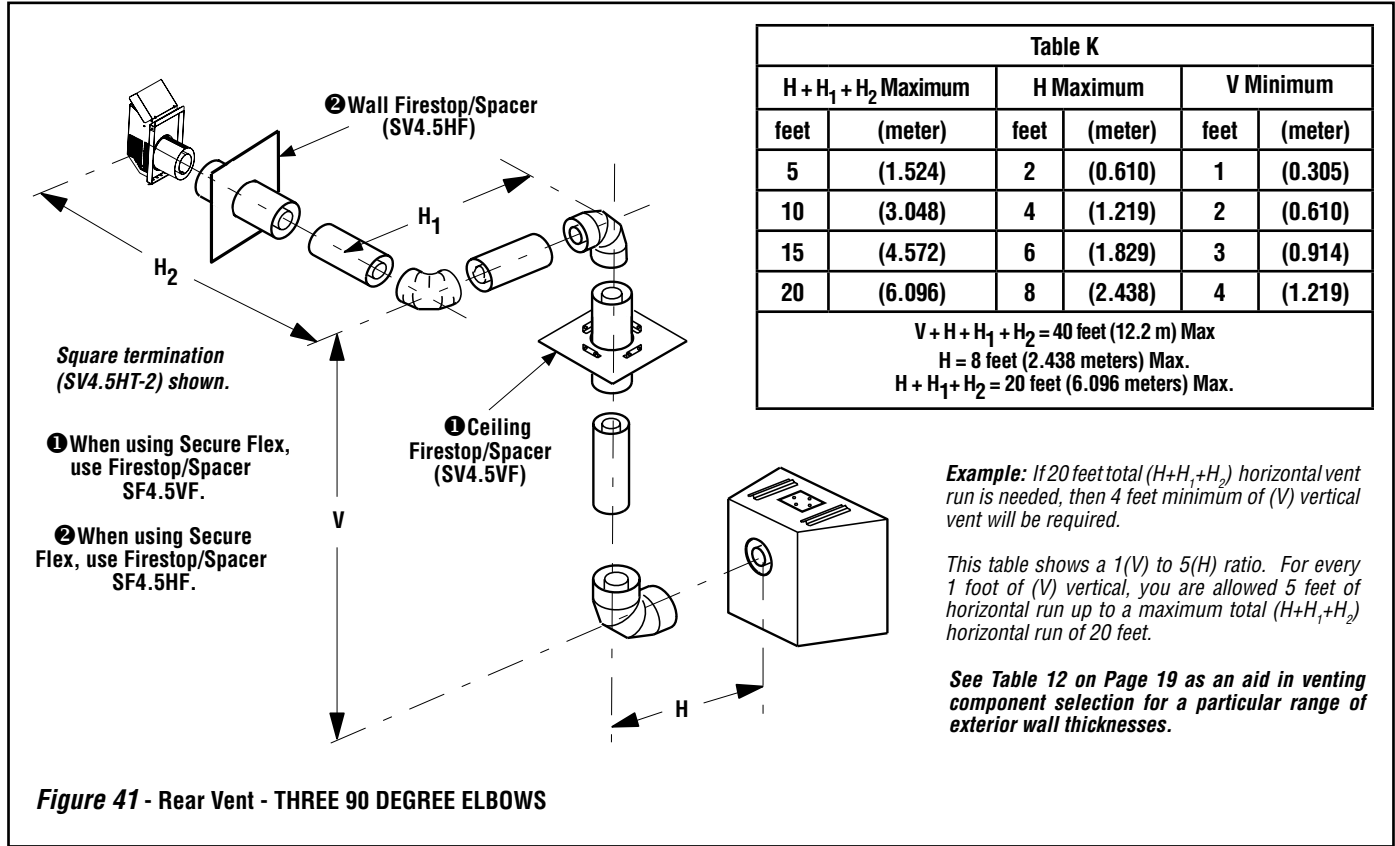

VERTICAL OR HORIZONTAL VENTING USING SECURE FLEX KITS AND COMPONENTS

Secure Flex venting kits and components may be used in any venting application in place of rigid **Secure Vent** (SV4.5) direct vent components. All restrictions, clearances and allowances that pertain to the rigid piping apply to the flexible venting. **Secure Flex kits may not be modified; also, under no circumstances may separate sections of flex pipe be joined together.**

Using adapter (SV4.5RF), **Secure Flex** kits may be added to the end of a vent run made up of rigid **Secure Vent** (SV4.5) vent sections provided that doing so does not violate any of the venting length, height, routing, horizontal to vertical ratio requirements or clearance considerations detailed in this manual.

Secure Flex kits come with an adapter that can be fitted to the inclined channel end of the last **Secure Vent** (SV4.5) vent section in a rigid system in the exact same fashion as any other **Secure Vent** section. Align the dimpled end of the adapter over the previously installed section or appliance collar, adjusting the radial alignment until the four locking dimples of the adapter are aligned with the inlets of the four incline channels of the last vent section or collar. Push on the adapter until it fully engages, then twist the adapter clockwise running the dimples down and along the incline channels until they seat at the end of the channels.

Attach the flexible vent to the adapter as follows (see also **Figure 43**):

A. Install the Inner Flex Pipe -

1. Install the small gear clamp loosely around the inner flexible vent pipe, push it back out of the way.
2. Apply a bead of **Mill-Pac Black (700° F) high temperature sealant - Catalog No. 10K81** to the inner adapter collar, approximately 1/2 inch from the end.
3. Pull and extend the inner flexible vent pipe.
4. Slide the inner flex pipe over the adapter collar. Ensure the flexible vent pipe completely engages the adapter collar to a distance of 1 3/4 inches from the end, and that it is free from damage or tears.
5. Slide the gear clamp down and tighten it fully to secure the flexible vent to the adapter inner collar approximately 3/4 inch from the end of the flex.
6. Install **three screws 120 degrees apart** through the flexible vent pipe and into the adapter collar just below the gear clamp to provide additional security to the connection.

Note: Outer Pipe Is Pulled Away To Show The Detail of The Inner Pipe

APPLY ONLY MIL-PAC BLACK HIGH TEMPERATURE SEALANT (Cat. No. 10K81) to the outside surface of both collars of the adapter (be especially careful to fill the grooves of the outer collar to be covered by the flexible pipe) and slide flexible pipe over inner and outer adapter collars.

1 3/4 inch (44 mm) Flexible Pipe and Adapter Outer Collar Overlap

Adapter (SV4.5RF)

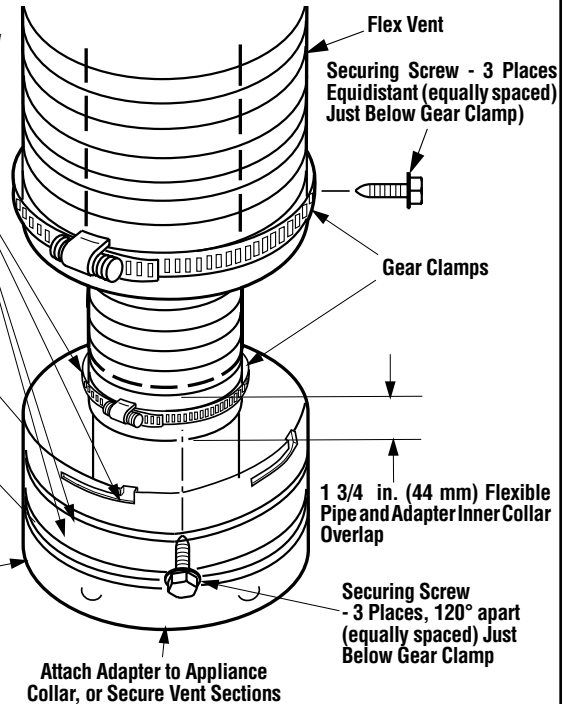

Figure 43

B. Install the Outer Flex Pipe -

1. Install the large gear clamp loosely around the outer flexible vent pipe, push it back out of the way.
2. Apply a bead of **Mill-Pac Black (700° F) high temperature sealant - Catalog No. 10K81** to the outer adapter collar; to the grooves of the collar which extend approximately 1 inch from the end and to the flat surface, approximately 1-3/8 inches from the end.
3. Pull and extend outer flexible vent pipe.
4. Slide the outer flex pipe over the adapter collar. Ensure the flexible vent pipe completely engages the adapter collar to a distance of 1-3/8 inches from the end, and that it is free from damage or tears.
5. Slide the gear clamp down and tighten it fully to secure the flexible vent to the adapter outer collar approximately 3/4 inch from the end of the flex.
6. Install **three screws 120 degrees apart** through the flexible vent pipe and into the adapter collar just below the gear clamp to provide additional security to the connection.

C. Route Flex Vent -

Ensure that the flex vent is properly routed to provide the required clearance. **Do not** allow the flexible vent to bend in a radius tighter than 5" (127 mm). Refer to **Figure 44**. Space out the internal flex vent spacers evenly - approximately every 6 inches - and avoid kinking of inner pipe. Support horizontal sections of flex with metal straps at 2 foot (0.61 m) intervals.

D. Install Firestop / Spacers at ceilings and walls

- When **Secure Flex** penetrates a wall or ceiling, a firestop / spacer is required: use the SF4.5 VF firestop / spacer for ceilings and the SF4.5 HF firestop / spacer for walls. See the appropriate sections and Figures shown throughout the venting section for their installation requirements.

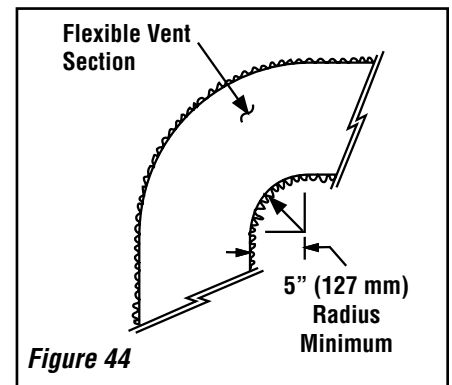

Figure 44

E. Attach Flex Vent to Termination -

Secure Flex components can be purchased separately and attached to bulk lengths of **Secure Flex** flexible tubing cut to size at the job site. Secure the flexible vent to the **Secure Flex** terminations in the same manner (see **Figure 43**) as it was attached to the adapter.

Note: Secure Flex vent must be attached to Secure Flex terminations only. DO NOT substitute Secure Vent terminations or the Secure Vent adapter for Secure Flex components. The collars of Secure Flex terminations and adapters have a different diameter than that used with the Secure Vent pipe. Additionally, Secure Flex components have an extended length center tube for use in attaching the flexible vent.

NOTE: DIAGRAMS & ILLUSTRATIONS ARE NOT TO SCALE.

Step 4. FIELD WIRING

CAUTION

Label all wires prior to disconnection when servicing controls. Wiring errors can cause improper and dangerous appliance operation.

CAUTION

Ensure that wires are positioned away from hot surfaces and sharp edges.

CAUTION

Do not connect the optional wall switch for burner operation to a 120 Volt AC power supply.

Refer to Section A for millivolt appliances and Section B for electronic appliances. The gas valve is set in place and pre-wired at the factory on both models.

A. SIT and Honeywell Millivolt Wiring (See Figure 45)

1. Select any of the following optional controls: appliance-mounted (rocker switch) or wall-mounted switch, thermostat, or one of the optional remote control kits. If appliance-mounted ON/OFF control is selected mount it in the gas valve mounting bracket.
2. If wall-mounted ON/OFF control or thermostat is selected mount it in a convenient location on a wall near the fireplace.

3. Wire the control within the millivolt control circuit using the 15 feet of 2 conductor wire supplied with the unit. **Caution: do not connect the optional wall switch to a 120V power supply.**
4. Alternatively, the appliance may be operated without the use of the controls indicated in step 1, solely by manipulating the gas valve control knob. In order to use this method, twist the free ends of the two conductor wire (which would otherwise go to the standard ON/OFF switch or Optional Switch) together as shown in **Figure 45**. Note: Wire is located inside the control compartment

Note: The supplied 15 feet of 2 conductor wire has one end of each conductor connected to the gas valve circuit and the other end of each conductor placed loose inside the control compartment.

B. Electronic Wiring (See Figure 47) –

Note: The electronic appliance must be connected to the main power supply.

The junction box is located on the right side of the appliance. It contains a factory installed and wired outlet box (duplex receptacle). Also, an optional field-provided junction box with receptacle may be installed at the front of the control compartment on either side of the cabinet. **See Figure 46**. It will be held in place by a conduit fitting and locknut (field-provided).

1. Route a 3-wire 120Vac 60Hz 1ph power supply to the appliance junction box.
2. If the factory-provided outlet/junction box at the right rear of the fireplace is being used, remove the outlet box from the junction box by removing two screws.

3. Connect the power supply wires (including the ground supply wire) as shown in **Figure 47**. (If the field-provided J-box/outlet box is being used, all of the outlet box wiring must be field-provided).
4. Locate and install a low voltage (24V) wall-mounted switch or thermostat (both field-provided) in the desired location.
5. Connect the low voltage wire, located inside the control compartment, to the wall-mounted switch or thermostat.

Note: The supplied 15 feet of 2 conductor wire has one end of each conductor connected to the gas valve circuit and the other end of each conductor placed loose inside the control compartment.
6. Insert the control circuit plug into the unswitched receptacle of the outlet box.
7. After wiring is complete, mount the outlet box to the J-Box.

Note: The gas valve-mounted ON/OFF switch is shown in **Figure 47**. It is integral with the gas valve and should be set to the ON position.

Step 5. WIRING - OPTIONAL FORCED AIR BLOWER KIT

FBK-100, FBK-200 and FBK250 Kits (See Figure 47) -

An electrical outlet box (receptacle) is factory-provided for the installation of the **FBK-100, FBK-200 and FBK-250** forced air blower kits. (An optional field-provided outlet box/J-Box may also be used. Electrical power must be connected to either of these receptacles in order to operate these blowers. Install the blower kits according to the installation instructions provided with the kits.

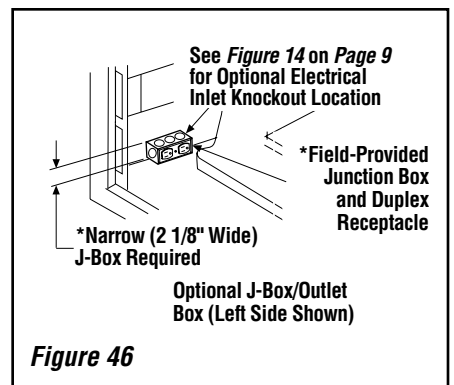
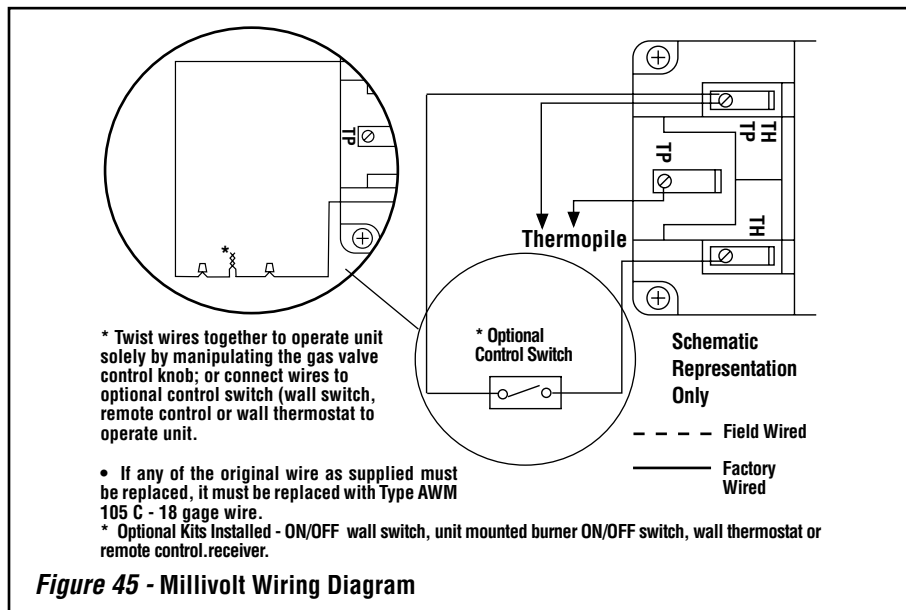

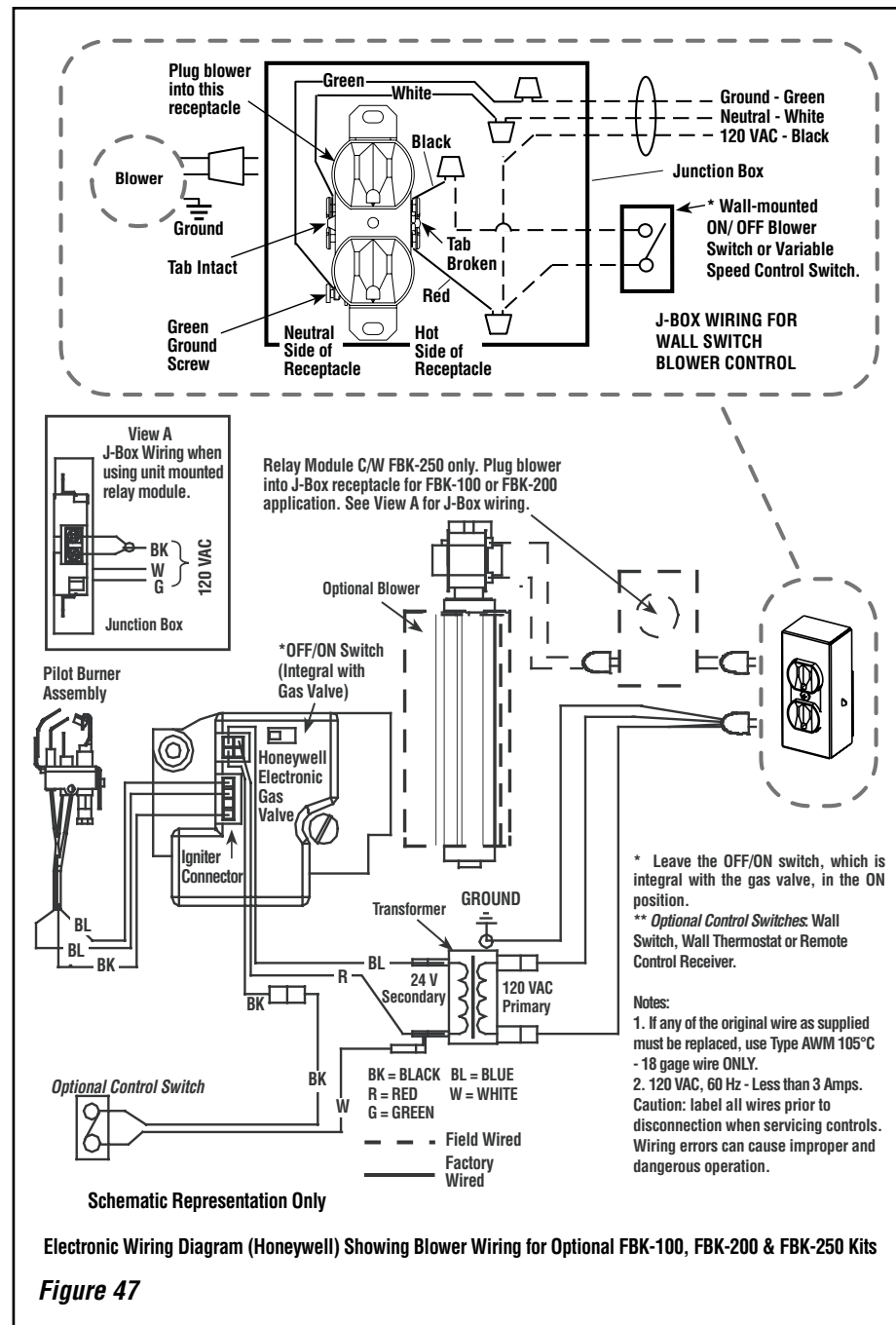

CAUTION

Ground supply lead must be connected to the wire attached to the green ground screw located on the outlet box. See Figure 47. Failure to do so will result in a potential safety hazard. The appliance must be electrically grounded in accordance with local codes or, in the absence of local codes, the National Electrical Code, ANSI/NFPA 70-latest edition. (In Canada, the current CSA C22-1 Canadian Electrical Code).

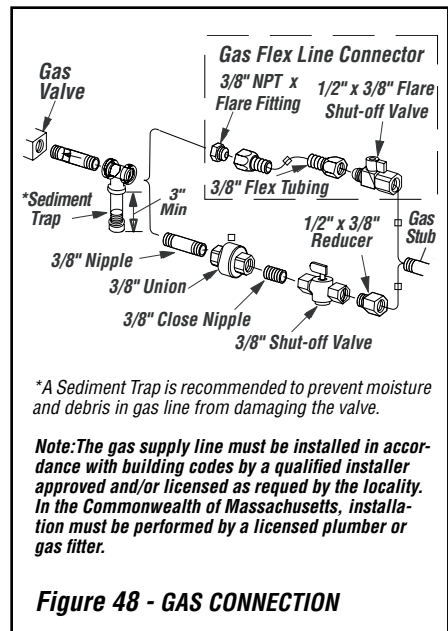

Step 6. CONNECTING GAS LINE

Make gas line connections. All codes require a shut-off valve mounted in the supply line. **Figure 48** illustrates two methods for connecting the gas supply. The flex-line method is acceptable in the U.S., however, Canadian requirements vary depending on locality. Installation must be in compliance with local codes.

These appliances are equipped with a gas flex line for use (where permitted) in connecting the appliance to the gas line. A gas flex line is provided to aid in attaching the direct vent appliance to the gas supply. The gas flex line can only be used where local codes permit. See **Figure 48** for flex line description. The flex line is rated for both natural gas and propane gas. A manual shut off valve is also provided with the flex line.

The incoming gas line should be piped into the valve compartment and connected (see **Figures 48 & 49**). The millivolt control valve has a 3/8" (10 mm) NPT thread inlet port. The electronic control valve has a 1/2" (13 mm) NPT thread inlet port and is fitted with a 1/2" x 3/8" (13 mm x 10 mm) NPT fitting.

Secure all joints tightly using appropriate tools and sealing compounds (ensure propane resistant compounds are used in propane applications).

Optional: Seal around the gas line to prevent cold air leakage.

TEST ALL CONNECTIONS FOR GAS LEAKS (FACTORY AND FIELD):

! WARNING
Never use an open flame to check for leaks.

Turn on gas supply and test for gas leaks using a gas leak test solution (also referred to as bubble leak solution). **Note:** Using a soapy water solution (50% dish soap, 50% water) is an effective leak test solution but it is not recommended, because the soap residue that is left on the pipes/fittings can result in corrosion over time.

- A. Light the appliance (refer to the lighting instructions label in control compartment or homeowner's manual).
- B. Brush all joints and connections with the gas leak test solution to check for leaks. If bubbles are formed, or gas odor is detected, turn the gas control knob (off/pilot/on) to the "OFF" position. Either tighten or refasten the leaking connection, then retest as described above.
- C. When the gas lines are tested and leak free be sure to rinse off the leak testing solution,
- D. Turn on burner then observe the individual tongues of flame on the burner. Make sure all ports are open and producing flame evenly across the burner. If any ports are blocked, or partially blocked, clean out the ports.

CONTROL COMPARTMENT ACCESS / LOUVER PANEL INSTRUCTIONS (Ref. Figure 49)

NOTE: The top louvered panel and the bottom louvered control panel door remove and install the same way as follows:

The gas controls can be found behind the control compartment access door.

Removing Control Compartment Door:

Open the door by gently lifting it upward until the hook catches on both sides clear the locating slots. Then pull door out to remove.

On millivolt systems, the piezo igniter, HI/LO flame adjustment knob, and pilot and main gas OFF/ON control knob are located below the glass panel enclosure. The gas valve for electronic systems is also located below the glass enclosure panel. See **Figure 50**.

Reinstalling Control Compartment Door:

To reinstall, insert the hook catches on each side of the door into the corresponding slots in the control compartment opening, then gently push forward and slide down until it locks in place.

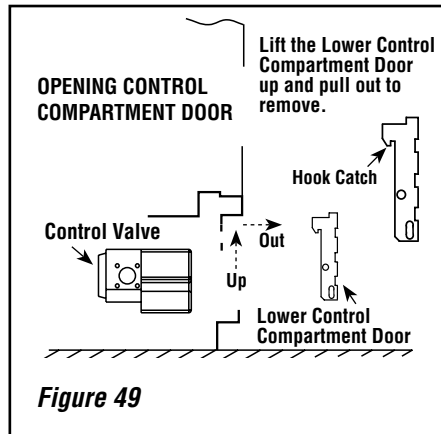

Step 7. CHECKING APPLIANCE OPERATION

With the gas line installed, run initial system checkout before closing up the front of the appliance. Follow the pilot lighting instructions provided in the Homeowner's Care and Operation Instructions. For piezo igniter location see **Figure 50** (millivolt appliances only).

Note: The (pull-out) Lighting instructions label can be found in the control compartment (see Figure 50).

When first lighting the appliance, it will take a few minutes for the line to purge itself of air. Once purging is complete, the pilot and burner will light and operate as indicated in the instruction manual. Subsequent lightings of the appliance will not require such purging. Inspect the pilot flame.

SIT and Honeywell Millivolt Appliance Checkout

The pilot flame should be steady, not lifting or floating. Flame should be blue in color with traces of orange at the outer edge.

The top 3/8" (10 mm) at the pilot generator (thermopile) and the top 1/8" min (tip) of the quick drop out thermocouple should be engulfed in the pilot flame. The flame should project 1" (25 mm) beyond the hood at all three ports (**Figure 51 - SIT, Figure 52 - Honeywell**)

To light the burner; rotate the gas valve control knob counterclockwise to the "ON" position then turn "ON" the OFF/ON switch (installed at **Step 4**).

Observe the individual tongues of flame on the burner. Make sure all ports are open and producing flame evenly across the burner. If any ports are blocked, or partially blocked, clean out the ports.

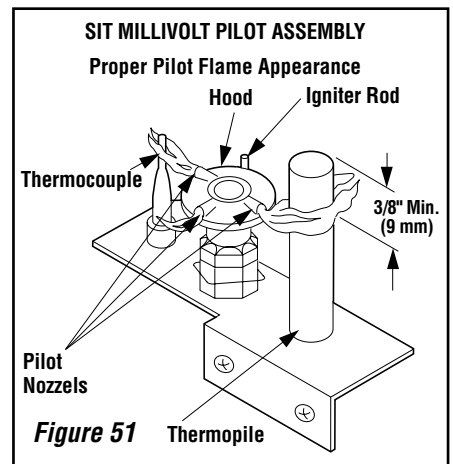
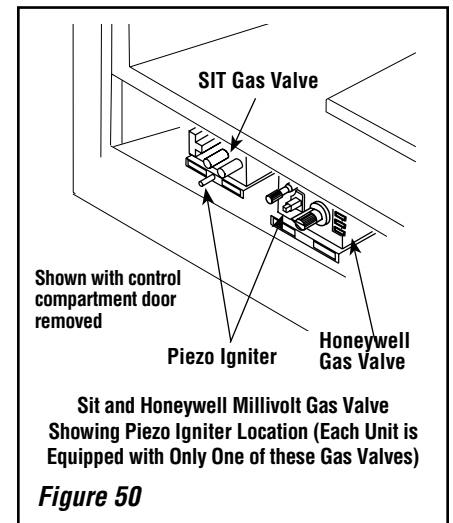

Replace logs if removed for pilot inspection. To light the burner; turn "ON" the remote wall switch and rotate the gas valve control knob counterclockwise to the "ON" position.

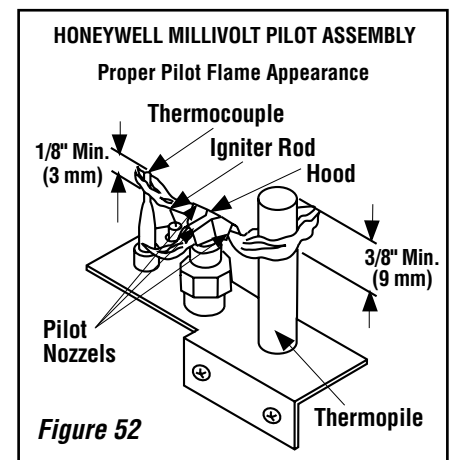

Electronic Appliance Checkout

To light the burner, turn 'ON' the optional remote wall switch and turn the gas control switch to the "ON" position. Ensure the Igniter lights the pilot. The pilot flame should engulf the flame rod as shown in *Figure 53*.

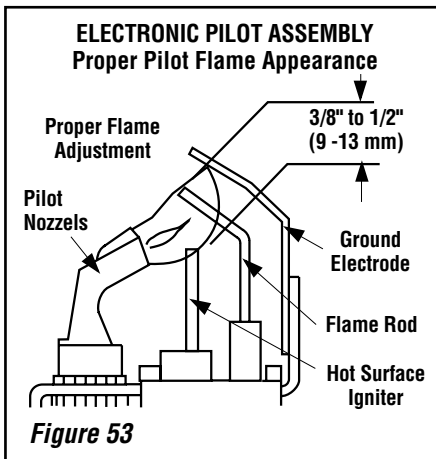

Step 8. INSTALL VERMICULITE, VOLCANIC STONE, GLOWING EMBERS AND LOGS

1. **Remove the front glass enclosure panel** (see *Removing Glass Enclosure Panels on Page 31*).

2. **Remove log set box from firebox.** Next, remove embers and vermiculite from control compartment. **Handle logs carefully to prevent breakage.**

3. **Install Vermiculite-** Place some vermiculite on the firebox floor around the burner (the entire bag of vermiculite will NOT be used). See *Figures 55 & 56*. **DO NOT PLACE ANY VERMICULITE ON THE BURNER.** Mound up a portion of the vermiculite in front of the burner.

4. **Install decorative volcanic stone** - Sprinkle the decorative volcanic stone (dark colored) on top of the vermiculite (light colored) in a pleasing pattern (see *Figures 55 & 56*).

5. **Placement of Glowing Embers** - Separate the Embers (rockwool) into pieces about the size of a quarter (see *Figure 54*). Keep the pieces fluffed up, not matted. Distribute these pieces over the surface of the burner, as shown in *Figures 55 & 56*. Do not use more than is necessary. Ensure that the main burner slots remain uncovered by the ember material.

Note: This appliance is provided with enough Glowing Embers for several applications, do not use all that is in a new bag at one time. For best glowing effect, replace the ember material annually.

6. Placement of Logs and Twigs -

All logs that have locating notches or slots to help ensure that they are properly positioned. All top logs that rest on lower logs, do so over notches, indents or pins. Proper twig placement is critical to prevent sooting. Twigs should be placed in the gaps between the flame peaks and should be positioned so they do not impinge the flames.

LMDV-3328 & LMDV-3530 - Install as Follows

Carefully position the ceramic fiber logs and twigs over the burner as shown in *Figure 55*. Logs should be placed in the order shown and per the following instructions.

1. Place the rear log (A) as shown. Position the 2 notches on the bottom of the log over the 2 corresponding locating brackets against the back wall of firebox.
2. Place the left log (B) as shown. The notch on the bottom of the log should fit over the corresponding locating bracket.
3. Place the right log (E) as shown. The hole on the back of the log should fit over the corresponding pin on the rear log (A). Make sure that the log is positioned so it aligns to the sides of the gas ports on the corner of the burner.
4. Place the left center log (C) as shown. The forked end of the log fits into the corresponding notch on rear log (A). The slot on the other end (bottom) of log fits over the corresponding locating bracket on the sub-floor.
5. Place the right center log (D) as shown. One end of the log fits into the corresponding indent on the right log (E). The slot on the other end (bottom) of log fits over the corresponding locating bracket on the sub-floor.

LMDV-4035 - Install as Follows

Carefully position the ceramic fiber logs and twigs over the burner as shown in *Figure 56*. Logs should be placed in the order shown and per the following instructions.

1. Position the center log (C) onto the 2 corresponding location pins on the burner.
2. Place the rear log (A) as shown. Position the 2 notches on the bottom of the log over the 2 corresponding locating brackets against the back wall of firebox.
3. Place the left log (B) as shown. The notch on the bottom of the log should fit over the corresponding locating bracket.
4. Place the right log (E) as shown. The notch on the bottom of the log should fit over the corresponding locating bracket. Make sure that the log is positioned so it aligns to the sides of the gas ports on the corner of the burner.
5. Place the center front log (D) as shown. The slot in the bottom of the log fits over the corresponding location bracket on the sub-floor.

WARNING

DO NOT attempt to install the logs until the appliance installation has been completed, the gas line connected and tested for leaks and the initial burner operation has been checked out.

NOTE: DIAGRAMS & ILLUSTRATIONS ARE NOT TO SCALE.

WARNING

The size and position of the log set was engineered to give the appliance a safe, reliable and attractive flame pattern. Any attempt to use a different log set in the fireplace will void the warranty and will result in incomplete combustion, sooting, and poor flame quality.

WARNING

This appliance is not designed to burn wood. Any attempt to do so could cause irreparable damage to appliance and prove hazardous to your safety.

WARNING

If logs are not installed according to the log installation instructions, flame impingement and improper combustion could occur and result in soot and/or excessive production of carbon monoxide (CO), a colorless, odorless, toxic gas.

Glowing Embers

Separate into Quarter Size (separate) Pieces

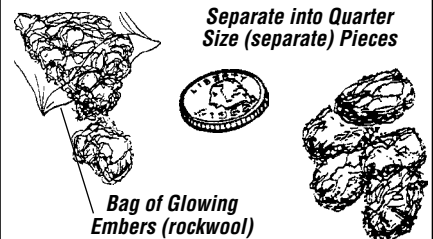

Figure 54

REFERENCE Firebox Accessories / Parts

Cat. No.	Model No.	Description
88L53	FGE	Bag of Glowing Embers (1 oz. rockwool)
H3696		Vermiculite, Bag (2 liters)
80L42	FDVS	Bag of Decorative Volcanic Stone

Table 13

MODEL LMDV-3328 & LMDV-3530 Log Placement Instructions

LOG SET Catalog Number H3366	
* Item	Description
A	Log, Rear
B	Log, Left
C	Log, Left Center
D	Log, Right Center
E	Log, Right
* Item "letters" above correspond to photos	

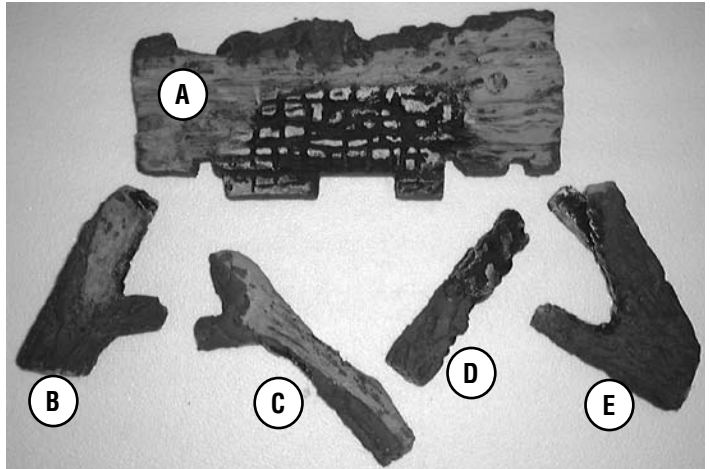

Install the Embers, Vermiculite, Volcanic Stone and Logs in the order shown here (1 through 6) and per the instructions on Page 26.

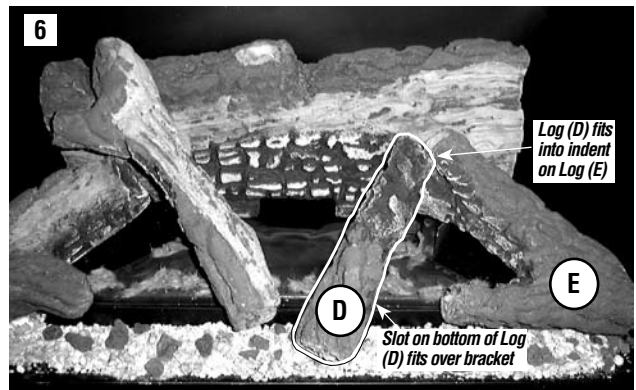
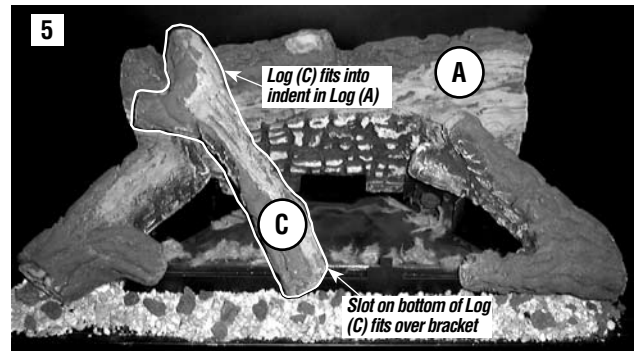
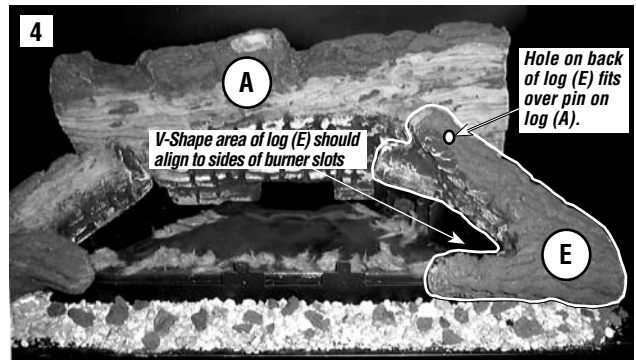
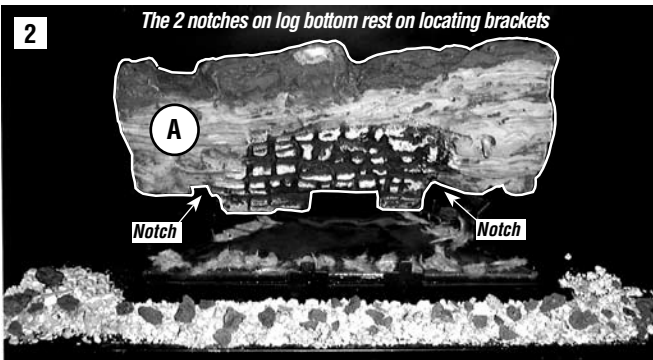
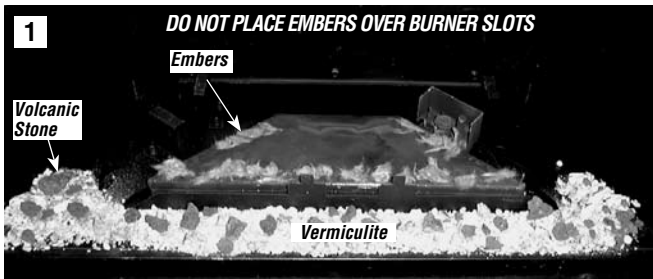
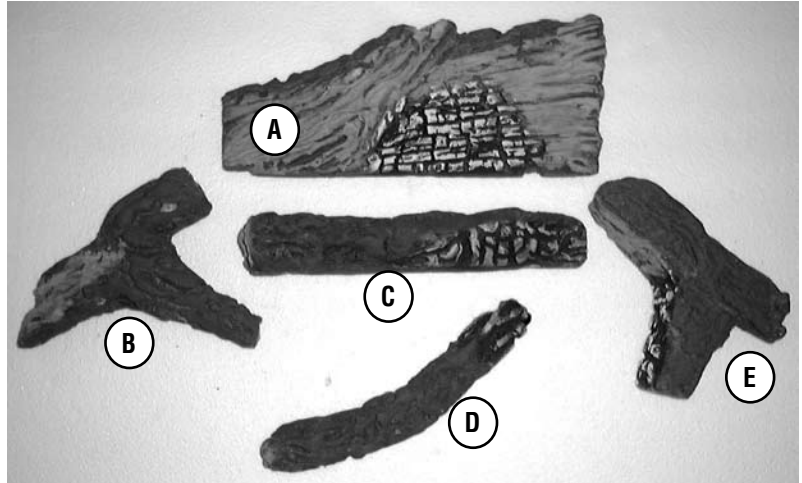

Figure 55

MODEL LMDV-4035 Log Placement Instructions

LOG SET Catalog Number H3365	
* Item	Description
A	Log, Rear
B	Log, Left
C	Log, Center
D	Log, Center Front
E	Log, Right
* Item "letters" above correspond to photos	



Install the Embers, Vermiculite, Volcanic Stone and Logs in the order shown here (1 through 6) and per the instructions on Page 26.

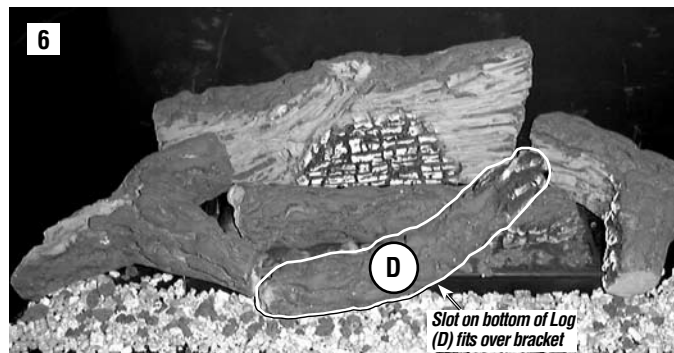
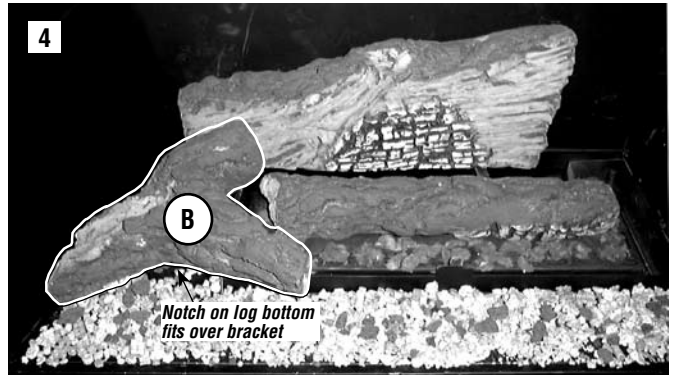
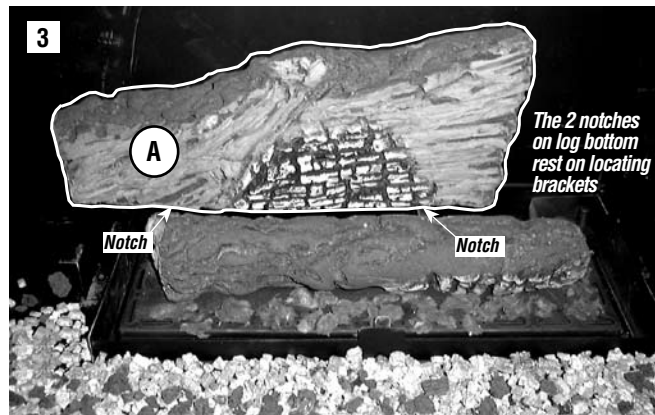
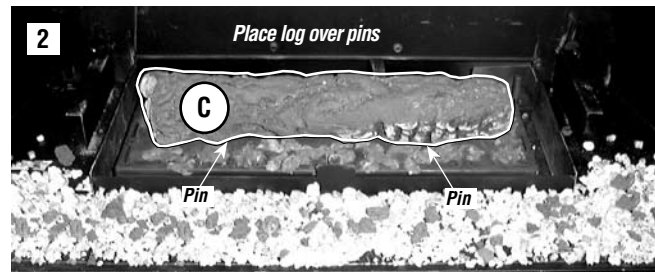
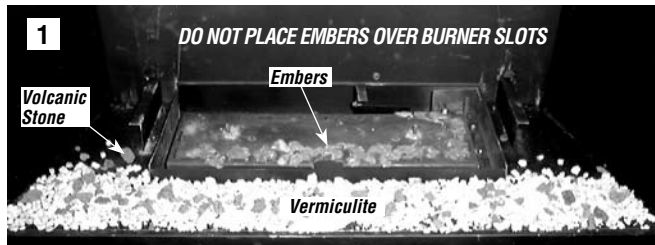

Figure 56

Step 9. INSTALLING THE GLASS DOOR

⚠ WARNING

Do not operate appliance with the glass front removed, cracked or broken. Replacement of the glass should be done by a licensed or qualified service technician.

⚠ WARNING

Do not attempt to substitute the materials used on this door, or replace cracked or broken glass with any materials other than those provided by the appliance manufacturer.

⚠ WARNING

Handle this glass with extreme care! Tempered glass is susceptible to damage – do not scratch or handle roughly while reinstalling the glass door frame.

⚠ WARNING

The glass door of this appliance must only be replaced as a complete unit as provided by the manufacturer. Do not attempt to replace broken, cracked or chipped glass separately.

⚠ WARNING

Do not attempt to touch the front enclosure glass with your hands while the fireplace is in use.

Removing Glass Enclosure Panels (see Figure 57)

1. Remove the top louver assembly by gently lifting it upward until the hook catches on both sides clear the locating slots. Then pull door out to remove.
2. Remove the control compartment access door the same way as described in Step 1 above.
3. Locate the two (2) latches at the top of the control compartment. To disengage the two latches from the bottom vee-flange of the glass enclosure panel, reach for the handles located towards the back of the latches and pull the handles down toward the front of the appliance.
4. Swing the bottom of the door out and raise it slightly to lift the top flange of the door frame away from the appliance.

Installing Glass Enclosure Panels (see Figure 57)

1. Visually inspect the gasket on the backside of the glass panel. The gasket surface must be clean, free of irregularities and seated firmly.
2. Position the glass enclosure panel in front of the firebox opening at a 45 degree angle and engage the top flange over the lip at the top of the firebox opening. **See Figure 57.**
3. Swing the glass enclosure panel down and back. Ensure the gasket seats evenly as the panel draws shut. Engage the Vee-flange at the bottom of the panel with the latches and close the latches to secure the panel.
4. Reinstall top louver assembly and control compartment door see installation instructions on **Page 25, Reinstalling Control Compartment Door.**

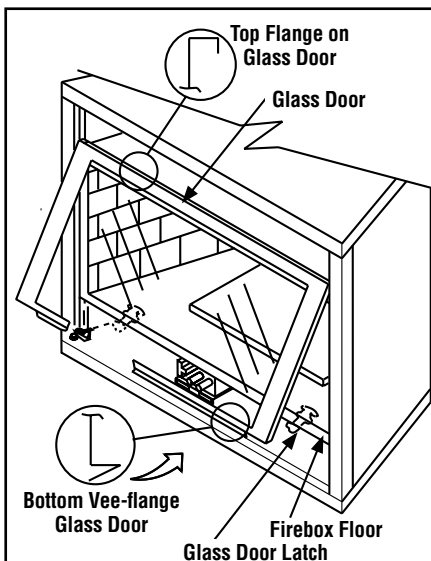

Figure 57 - INSTALLING GLASS DOOR

Step 10. BURNER ADJUSTMENTS

Flame Appearance and sooting

Proper flame appearance is a flame which is blue at the base and becomes yellowish-orange in the body of the flame. When the appliance is first lit, the entire flame may be blue and will gradually turn yellowish-orange during the first 15 minutes of operation. If after a short period the flame stays lowered blue, or if the flame is orange with evidence of sooting (black tip), the air shutter opening may need to be adjusted.

If the air shutter openings closed too far, sooting may develop. Sooting is indicated by black puffs developing at the tips of very long orange flames. Sooting results in black deposits forming on the logs, appliance inside surfaces and on exterior surfaces adjacent to the vent termination. Sooting is caused by incomplete combustion in the flames and lack of combustion air entering the air shutter opening. To achieve a warm yellowish-orange flame with an orange body that does not soot, the shutter opening must be adjusted between these two extremes.

NOTE: DIAGRAMS & ILLUSTRATIONS ARE NOT TO SCALE.

Air Shutter Adjustment Guidelines

- If there is smoke or soot present, first check the log set positioning to ensure that the flames are not impinging on any of the logs. If the log set is properly positioned and a sooting condition still exists, then the air shutter opening should be increased.
- The more offsets in the vent system, the larger the air shutter opening will need to be.
- An appliance operated with the air shutter opened too far, may have flames that appear blue and transparent. These weak, blue and transparent flames are termed anemic.
- Propane models may exhibit flames which candle or appear stringy. If this is present and persists, adjust the air shutter to a more closed position, then operate the appliance for a few more minutes to ensure that the flame normalizes and the flames do not appear sooty.

The following chart is provided to aid you in achieving the correct air shutter adjustment for your installation.

Air Shutter Adjustment Guidelines:		
Amount of Primary Air	Flame Color	Air Shutter Adjustment
If air shutter is closed too far →	Flame will be orange →	Air shutter gap should be increased
If air shutter is open too far →	Flame will be blue →	Air shutter gap should be decreased

⚠ WARNING

Air shutter adjustment should only be performed by a qualified professional service technician.

⚠ WARNING

Ensure front glass panel are in place and sealed during adjustment.

⚠ CAUTION

Carbon will be produced if the air shutter is closed too much. Any damage due to carboning resulting from improperly setting the air shutter is not covered under the warranty.

Burner Air Shutter Adjustment Procedure



The air shutter door and nearby appliance surfaces are hot. Exercise caution to avoid injury while adjusting flame appearance.

Burner Air Shutter Adjustment Procedure

1. Locate adjustment rod and adjust air shutter to the standard setting as shown in **Figure 60** (adjustment rod is located in the lower control compartment).
Note: Move the adjustment rod down to decrease air and up to increase air.
2. Light appliance (follow lighting procedure on lighting label in control compartment or see homeowners manual).
3. Allow the burner to operate for at least 15 minutes while observing the flame continuously to ensure that the proper flame appearance has been achieved (see **Figure 57 or 58**). If the following conditions are present, adjust accordingly.
 - If flame appears weak or sooty, adjust the air shutter, incrementally, to a more open position until the proper flame appearance is achieved.
 - If flame stays lowered blue, adjust the air shutter, incrementally, to a more closed position until the proper flame appearance is achieved.

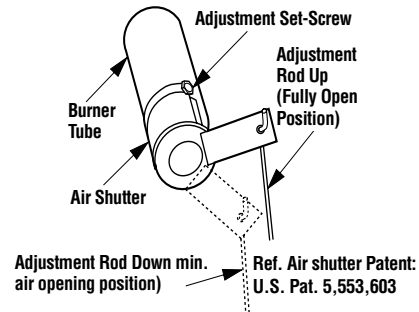

Figure 58 - Burner Flame Appearance Model LMDV-3328 & LMDV-3530



Figure 59 - Burner Flame Appearance Model LMDV-4035

4. Leave the control knob (off/pilot/on) in the ON position and the burner OFF/ON switch OFF (& remote switches, if applicable).
5. When satisfied that the burner flame appearance is normal, re-install the lower control compartment door then proceed to finish the installation.



Main Burner Factory Air Shutter Opening Setting - Inches (millimeter)

Model	Nat. Gas	Propane Gas
LMDVT-3328	1/16 (1.58)	1/4" (6.35)
LMDVR-3328	1/16 (1.58)	1/4" (6.35)
LMDV-3530	1/16 (1.58)	5/16" (7.94)
LMDV-4035	1/8 (3.18)	3/8" (9.53)

Figure 60 - Burner Air Shutter Adjustment

Step 11. HOOD INSTALLATION

(Refer to **Figure 61**) All of these appliances must have hoods installed prior to operating.

Install hood by sliding it into the slots on the lower edge of the cabinet top.

FINISHING REQUIREMENTS - Wall Details

Complete finished interior wall. To install the appliance facing flush with the finished wall, position framework to accommodate the thickness of the finished wall (**Figure 61**).

See Page 4 for Cold Climate Insulation and Page 7 for Clearances

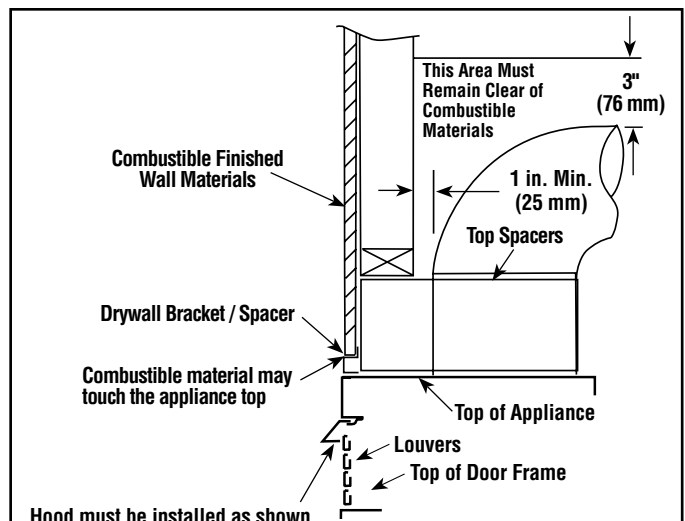

Hood must be installed as shown.

Figure 61 - Combustable Wall Framing

INSTALLATION ACCESSORIES

Item	Cat. No.	Model	Description
1	H1968	SV4.5HT-2	Horizontal Square Termination With Firestop / spacer (H2246) & Adapter (74L61)
2a	H2152	SV4.5CGV-1	Vertical Termination Cap
2b	H4687	SV4.5CTS	Chase Top Termination Square
2b	H4716	SV4.5CTS-B	Chase Top Termination Square, Black
2b	H4717	SV4.5CTS-TC	Chase Top Termination Square, Terra Cotta
3	77L70	SV4.5L6	6 Inch (152 mm) Vent Section
3	77L71	SV4.5L12	12 Inch (305 mm) Vent Section
3	77L72	SV4.5L24	24 Inch (610 mm) Vent Section
3	77L73	SV4.5L36	36 Inch (914 mm) Vent Section
3	77L74	SV4.5L48	48 Inch (1219 mm) Vent Section
3	77L75	SV4.5LA	Telescopic Section (1-1/2" to 7-1/2" effective length)
4	77L76	SV4.5E45	45 Degree Elbow
5	77L77	SV4.5E90	90 Degree Elbow
The following flashings come packaged with a storm collar:			
6	77L78	SV4.5F	Flat Roof Flashing
6	77L79	SV4.5FA	1/12 to 7/12 Adjustable Flashing
6	77L80	SV4.5FB	7/12 to 12/12 Adjustable Flashing
7	77L81	SV4.5SC6	Storm Collar (6 per box)
8	H2246	SV4.5HF	Firestop / Spacer-Horizontal (3-1-1 spacing), 10 Pack
8	H2247	SV4.5VF	Firestop / Spacer-Vertical (1-1-1 spacing), 10 Pack
9	96K93	SV4.5SU	Support Strap
10	H5816	SV4.5-TWSK	Through Wall Shield Kit (used to shield the direct-vent pipe from blown insulation)
11	96K92	SV4.5SP	Support Plate
12A	17M52	SV4.5HGS-1	Termination Guard, Square (1 pack) (for square termination)
12A	17M53	SV4.5HGS-12	Termination Guard, Square (12 pack) (for square termination)
12B	87L02	SV4.5HGS	Termination Guard for Square Termination (Deluxe) (1 pack) (for square termination)
12C	H5820	4.5HTSK	Termination Shroud (Guard) for Horizontal Square Termination (1 pack)

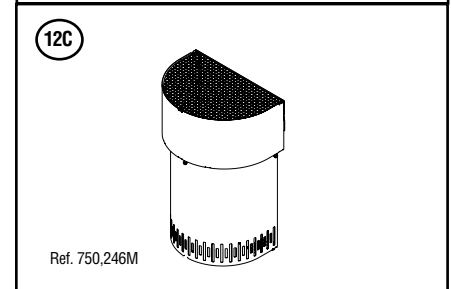
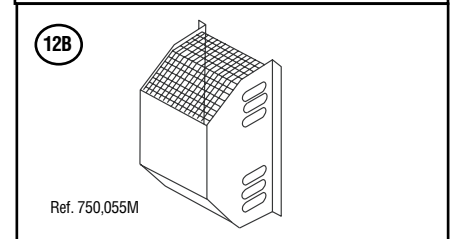
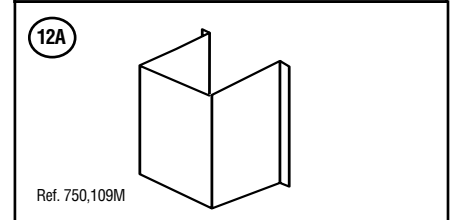
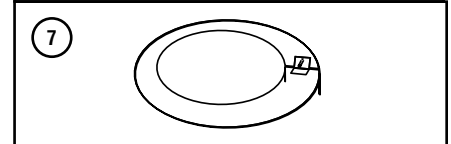
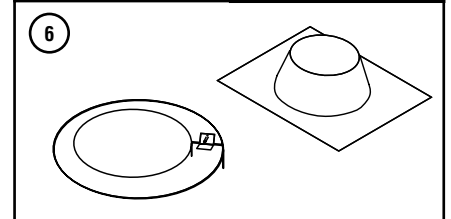
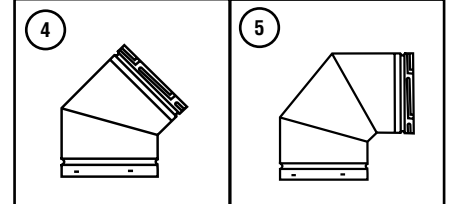
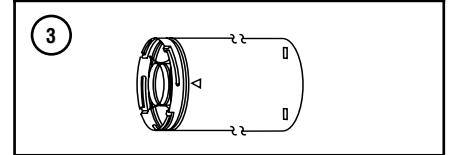
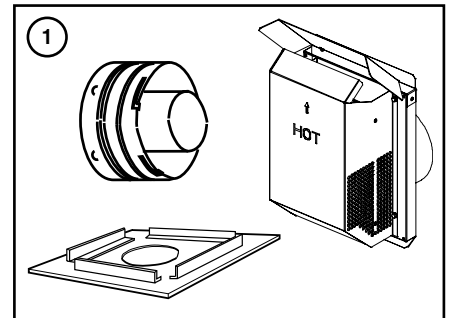
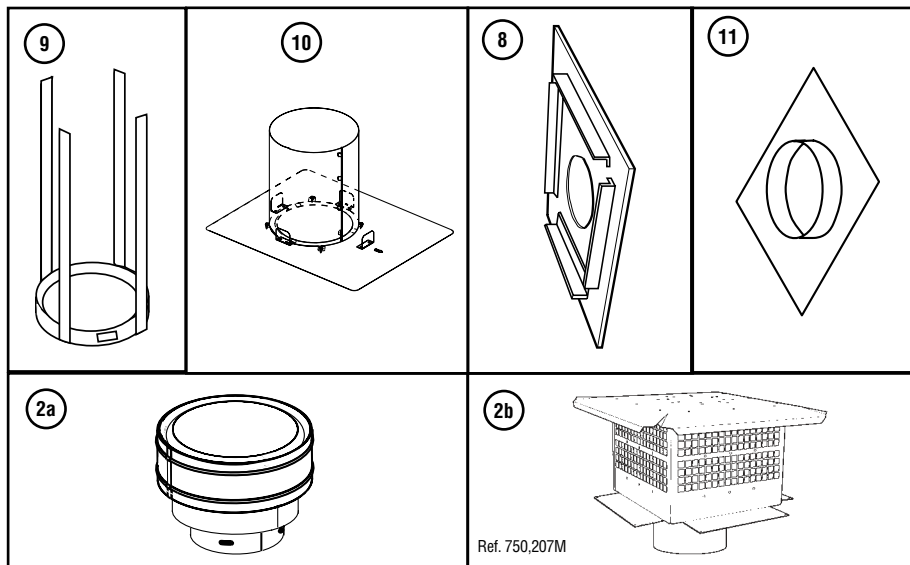

NOTE: DIAGRAMS & ILLUSTRATIONS ARE NOT TO SCALE.

INSTALLATION ACCESSORIES

Item	Cat. No.	Model	Description
18	H1969	SF4.5HT-2	Horizontal Square Termination (without flex)
18	77L87	SFKIT12S	Flex Square Term. (with 12 inch [305 mm] * compressed flex)
18	77L88	SFKIT18S	Flex Square Term. (with 18 inch [457 mm] * compressed flex)
18	77L89	SFKIT24S	Flex Square Term. (with 24 inch [610 mm] * compressed flex)
18	77L90	SFKIT36S	Flex Square Term. (with 36 inch [914 mm] * compressed flex)
18	77L91	SFKIT48S	Flex Square Term. (with 48 inch [1219 mm] * compressed flex)
19	56L74	SFVT30	Vertical Termination for flex (flat to 6/12) with flex adapter, section of rigid vent, roof support collar assembly, roof flashing and storm collar.
19	56L75	SFVT45	Vertical Termination for flex (6/12 to 12/12) with flex adapter, section of rigid vent, roof support collar assembly, roof flashing and storm collar.
*20	60L10	SF-18	18 ft. (5.49 m) * compressed flex
*20	98K03	SF-12	12 ft. (3.66 m) * compressed flex
22	10K81	SFMP	Mill-Pac, Black, High Temperature Sealant
22	89L40	SFMP-12	Mill-Pac, Black, High Temperature Sealant - Bulk 12 pack
23	91L66	SF-GC4-6	Gear Clamp 4.5 in. (114 mm) for flex (6 pieces)
23	91L67	SF-GC7-6	Gear Clamp 7.5 in. (190.5 mm) for flex (6 pieces)
24	99L02	SV4.5HRK14	Horizontal Riser Kit, 14"
24	99L03	SV4.5HRK36	Horizontal Riser Kit, 36"
25	H1988	CTSA-33	Chase Top Shroud Kit, Arch Top 3 X 3
26	H1985	CTSO-33	Chase Top Shroud Kit, Open Top 3 X 3
26	H1987	CTSO-44	Chase Top Shroud Kit, Open Top 4 X 4
26	H1986	CTSO-46	Chase Top Shroud Kit, Open Top 4 X 6
8	H2248	SF4.5HF	Firestop / Spacer - Horizontal (flex) (3-1-1 spacing), 10 Pack
8	H2249	SF4.5VF	Firestop / Spacer - Vertical (1-1-1 spacing), 10 Pack

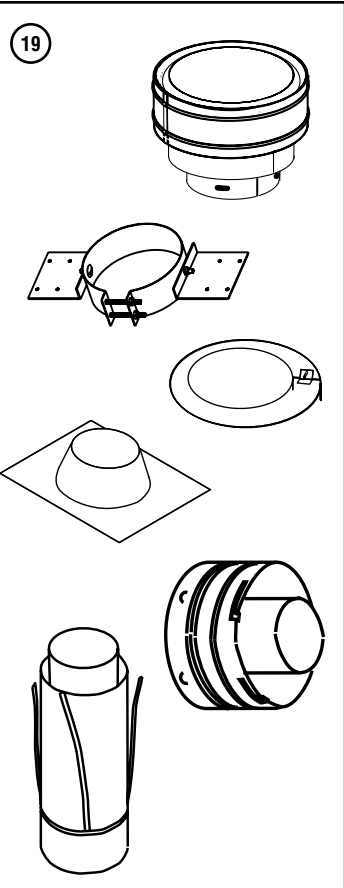

* All compressed flex vents can be expanded up to two times.

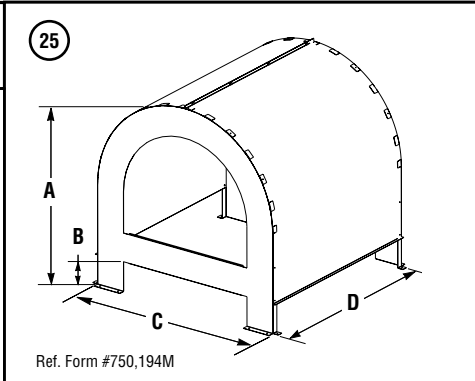
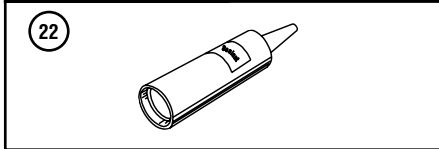
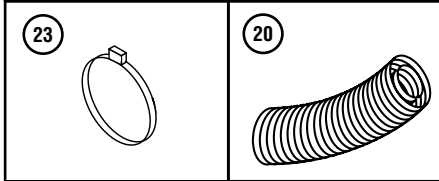
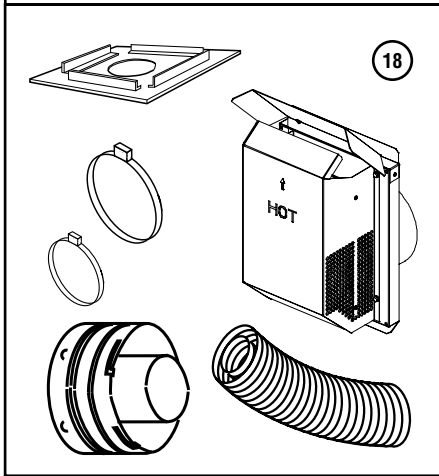

Arch Top, Chase Top Shroud Inches (millimeters)				
Model	A	B	C	D
CTSA-33	34" (864)	5" (127)	34" (864)	34" (864)

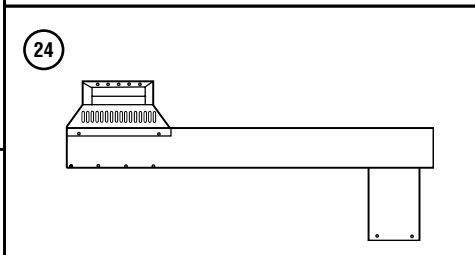

NOTE: DIAGRAMS & ILLUSTRATIONS ARE NOT TO SCALE.

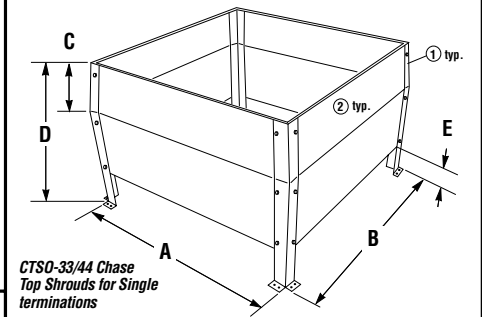
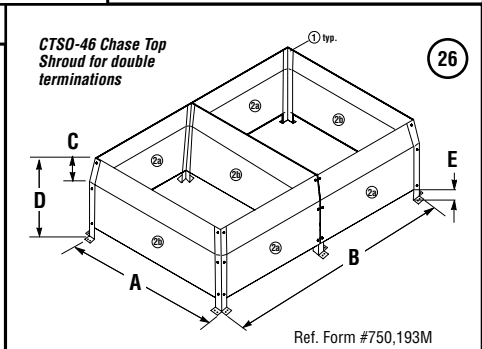

Open Top, Chase Top Shroud Inches (millimeters)					
Model	A	B	C	D	*E
CTSO-33	37-5/8 (955)	37-5/8 (955)	7-1/2 (191)	24-1/2 (622)	3 (76)
CTSO-44	48-5/8 (1235)	48-5/8 (1235)	7-1/2 (191)	24-1/2 (622)	3 (76)
CTSO-46	48-5/8 (1235)	73 1/4 (1860)	7-1/2 (191)	24-1/2 (622)	3 (76)

INSTALLATION ACCESSORIES

Listed Secure Flex™ Components LMDV-3328 & LMDV-3530 Models Only		
Cat. No.	Model	Description
94L04	SFKIT12SS	Flex - Small Square Termination with 12 in. (305 mm) of *compressed flex vent
94L05	SFKIT18SS	Flex - Small Square Termination with 18 in. (457 mm) of *compressed flex vent
94L06	SFKIT24SS	Flex - Small Square Termination with 24 in. (610 mm) of *compressed flex vent
94L07	SFKIT36SS	Flex - Small Square Termination with 36 in. (914 mm) of *compressed flex vent
94L08	SFKIT48SS	Flex - Small Square Termination with 48 in. (1219 mm) of *compressed flex vent
94L09	SF-HTSS	Horizontal Small Square Termination without flex vent
Listed Secure Vent™ Components - LMDV-3328 & LMDV-3530 Models Only		
94L10	SV4.5HTSS	Horizontal - Small Square Termination with Firestop/Spacer (H2246) & Adapter (74L61).
98L27	SV4.5HTSSL	Long Horizontal - Small Square Termination with Firestop/Spacer (H2246) & Adapter (74L61). 1 PACK
98L28	SV4.5HTSSL8	Long Horizontal - Small Square Termination with Firestop/Spacer (H2246) & Adapter (74L61). 8 PACK
<p>* All compressed flex vents can be expanded up to two times.</p>		

GAS CONVERSION KITS

Millivolt SIT Systems Natural Gas To Propane Gas Conversion Kits

Models	Cat. No.
LMDVT-3328 LMDVR-3328	H2009
LMDVT-3530	H2011
LMDVT-4035	H2013

Millivolt SIT Systems Propane to Natural Gas Conversion Kits

Models	Cat. No.
LMDVT-3328 LMDVR-3328	H2010
LMDVT-3530	H2012
LMDVT-4035	H2014

Millivolt HONEYWELL Systems Natural Gas To Propane Gas Conversion Kits

Models	Cat. No.
LMDVT-3328 LMDVR-3328	26M51
LMDVT-3530	26M52
LMDVT-4035	26M53

Millivolt HONEYWELL Systems Propane Gas To Natural Gas Conversion Kits

Models	Cat. No.
LMDVT-3328 LMDVR-3328	26M55
LMDVT-3530	26M56
LMDVT-4035	26M57

Electronic HONEYWELL Systems Natural Gas To Propane Gas Conversion Kits

Models	Cat. No.
LMDVT-3328 LMDVR-3328	26M59
LMDVT-3530	26M60
LMDVT-4035	26M61

Electronic HONEYWELL Systems Propane Gas To Natural Gas Conversion Kits

Models	Cat. No.
LMDVT-3328 LMDVR-3328	26M63
LMDVT-3530	26M64
LMDVT-4035	26M65

WARNING

This conversion kit shall be installed by a qualified service agency in accordance with the manufacturer's instructions and all applicable codes and requirements of the authorized having jurisdiction. If the information in these instructions is not followed exactly, a fire, explosion or production of carbon monoxide may result causing property damage, personal injury or loss of life. The installation is not proper and complete until the operation of the converted appliance is checked as specified in the owner instructions supplied with the kit. The qualified service agency performing this installation assumes responsibility for this conversion.

AVERTISSEMENT

Cet équipement de conversion sera installé par une agence qualifiée de service conformément aux instructions du fabricant et toutes exigences et codes applicables de l'autorité avoir la juridiction. Si l'information dans cette instruction n'est pas suivie exactement, un feu, explosion ou production de protoxyde de carbone peut résulter le dommages causer de propriété, perte ou blessure personnelle de vie. L'agence qualifiée de service est esponsable de l'installation propre de cet équipement. L'installation n'est pas propre et complète jusqu'à l'opération de l'appareil converti est chéque suivant les critères établis dans les instructions de propriétaire provisionnées avec l'équipement.

IMPORTANT/CANADA

The conversion shall be carried out in accordance with the requirements of the provincial authorities having jurisdiction and in accordance with the requirements of the CAN1-B149.1 And B149.2 Installation code.

**! IMPORTANT
LE CANADA SEULEMENT**

La conversion devra être effectuée conformément aux recommandations des autorités provinciales ayant juridiction et conformément aux exigences du code d'installation CAN1-B149.1 ET.2.

Gas conversion kits are available to adapt the appliance from the use of one type of gas to the use of another. These kits contain all the necessary components needed to complete the task including labeling that must be affixed to ensure safe operation.

Kit part numbers are listed here and the following steps detail the conversion procedure.

Step 1. Turn off the gas supply to the appliance. Remove the front glass door/frame from the appliance. Access the control compartment.

Step 2. Carefully remove the logs. Exercise care so as not to break the logs.

Step 3. Locate the screws securing the burner assembly to the appliance. Remove the burner assembly and retain the securing screws.

Step 4. Millivolt Appliances - SIT Systems

a. See **Figure 62** and the instructions provided with the kit. Using a Torx T20, tool or standard flat screwdriver remove and discard the three pressure regulator mounting screws. Remove the pressure regulator, spring, poppet, diaphragm and bushing. Discard all removed components. Ensure the rubber gasket installed on the back of the replacement pressure regulator is properly positioned and install the new pressure regulator using the new screws supplied with the kit. Tighten screws to 25 In. lb. torque.

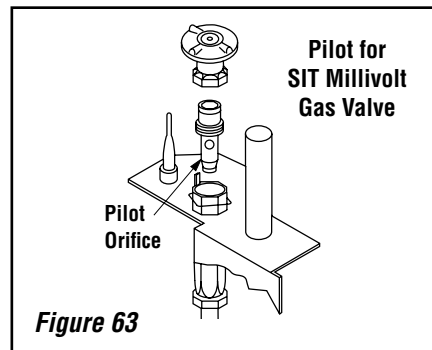
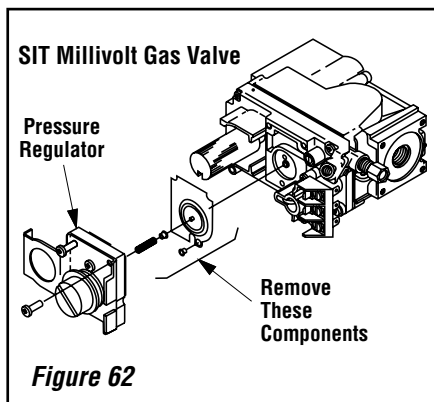

Figure 63

b. Attach manometer to the manifold side pressure test fitting and verify manifold pressure reads 3.5 inches water column (0.87 kPa) for natural gas, and 10.0 inches water column (2.49 kPa) for propane gas.
c. Refer to **Figure 63** and remove the pilot hood assembly to access the hexed pilot orifice. Remove and replace the orifice with the one provided with the kit.

Step 5. Millivolt Appliances

Honeywell Systems -

a. Convert the gas valve as follows (see **Figure 64**): Remove the plastic protecting cap. Remove the gas type setting screw by turning it counterclockwise. Obtain the replacement gas type setting screw from the kit and screw it into place (red for propane and blue for natural gas). Tighten the gas type setting screw by turning it clockwise. Replace the plastic protecting cap.

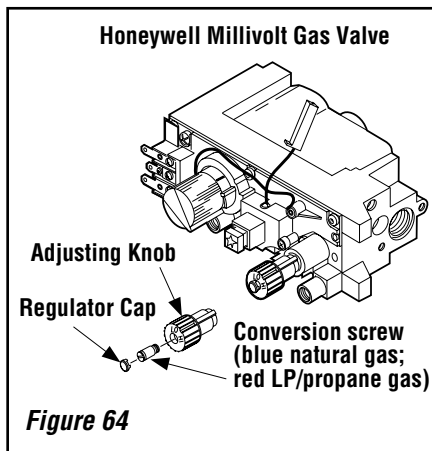

Figure 64

b. Attach manometer to the manifold side pressure test fitting and verify manifold pressure reads 3.5 inches water column (0.87 kPa) for natural gas, and 10.0 inches water column (2.49 kPa) for propane gas.

c. Convert the pilot orifice as follows (see **Figures 65 & 66**):

Note - Use extra care not to engage the orifice strip with the 7/16" open end wrench (contacting the orifice strip could cause strip distortion rendering the pilot inoperative). Also avoid wrench contact to any of the other pilot parts.

Use a 7/16" open end wrench and turn the pilot hex fitting counter-clockwise 1/4 turn. (See **Figure 66**).

Note - The orifice strip tab may be randomly located on any side of the hex fitting.

d. Push the orifice strip tab all the way against the hex fitting to align the appropriate gas type orifice (see **Figures 65 & 66**). The type of gas for which the pilot is set, is, the gas type shown on the tab.

e. Retighten, clockwise, the pilot hex fitting until the pilot hood aligns with the thermocouple and thermopile as indicated by the arrows shown in **Figure 66**.

Pilot for Honeywell Millivolt Gas Valve

Orifice Strip Tab Position Identification For LP (propane gas) and Natural Gas

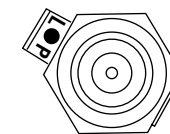

LP (propane) Gas Position - 1/16 inch hole, LP and red color shown on tab.

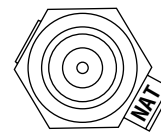

Natural Gas Position - NAT shown on tab.

Top View of Hex Fitting and Orifice Strip Tab

Figure 65

Pilot for Honeywell Millivolt Gas Valve (Loosening of Hex Fitting For Orifice Strip Tab Positioning)

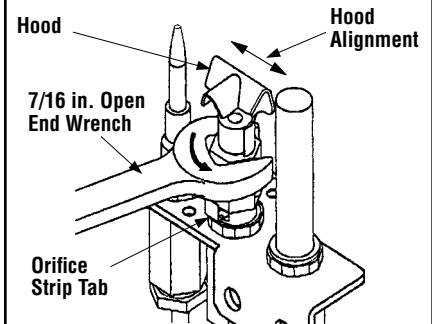

Take care not to contact the orifice strip tab with the hex fitting wrench - distortion of the tab may render the pilot inoperative.

Figure 66

**Step 6. Electronic Appliances -
Honeywell Systems**

See *Figure 67* and the instructions provided with the kit. Remove the slotted cap screw, o-ring, pressure-regulating adjusting screw and spring. Retain all parts for possible later use. Install new components from the kit. Black cap and red spring for propane gas units. Silver cap and stainless steel spring for natural gas units.

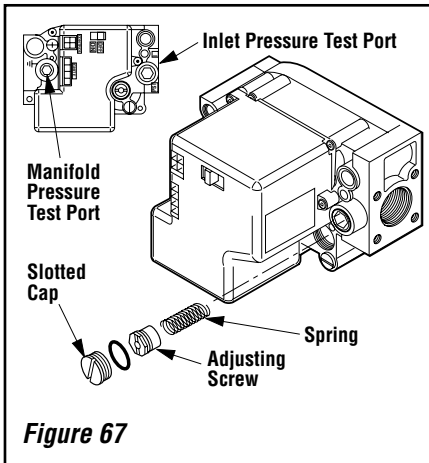

Figure 67

Before installing the cap, attach manometer to the manifold side pressure test fitting and adjust screw until pressure reads 3.5 inches water column (0.87 kPa) for natural gas, and 10.0 inches water column (2.49 kPa) for propane gas.

See *Figure 68* and replace the pilot orifice as follows: Remove the Igniter assembly retainer clip, and carefully remove the Igniter assembly.

Exercise extreme care to prevent damage to or breakage of the Igniter assembly. Remove the screw securing the pilot assembly to its mounting bracket. Back off the flare nut at the end of the pilot gas line to free the pilot assembly from the gas line. Remove the pilot orifice and replace it with the one provided with the conversion kit. Reinstall the pilot assembly by reversing the steps detailed here.

When reinstalling the Igniter assembly, use extreme care to prevent damage and breakage. Do not apply any leverage to the Igniter assembly while restoring the retainer clip to its original position.

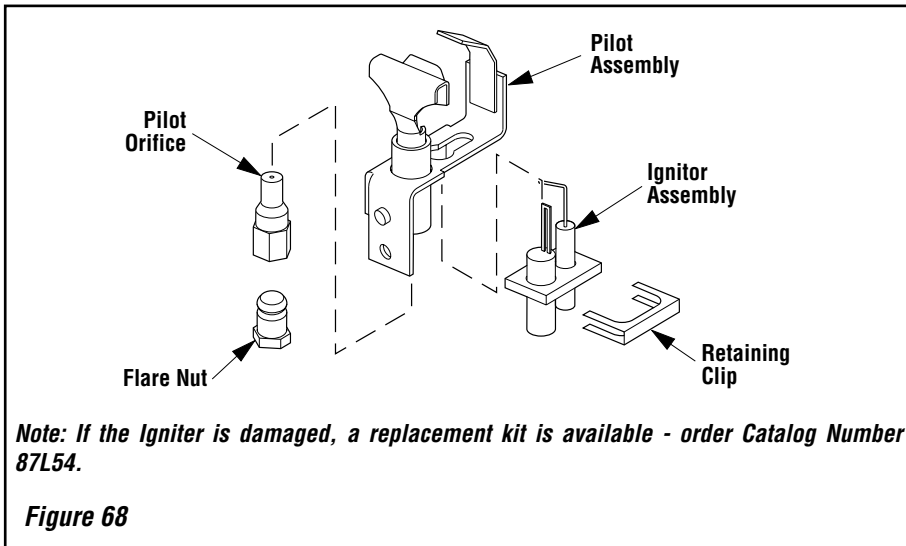

Figure 68

All Models

Step 7. Remove the burner orifice from the manifold and replace it with the one provided with the kit. See *Table 14* for orifice sizes required for use with natural gas or propane gas. *Figure 69* illustrates the orifice.

Burner Orifice Sizes Elevation 0-4500 feet (0-1372 meters)		
Model Series	Natural Gas drill size(inches)	Propane Gas drill size (inches)
LMDVT-3328 LMDVR-3328	#45 (.082") * 39L66 •	1.2mm (.048") * 99K78 •
LMDV-3530	#44 (.086") * 60J8001 •	#55 (.052") * 19L5201 •
LMDV-4035	#37 (.104") * 24M1001 •	1/16" (.062")* 21L0101 •

* Standard size installed at factory
• Part /Cat. Number
Table 14

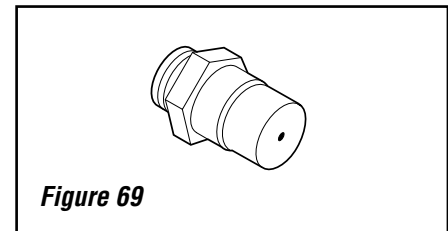

Figure 69

Step 8. Reassemble all removed components by reversing the procedures outlined in the preceding steps. Use pipe joint compound or Teflon tape on all pipe fittings before installing (ensure propane resistant compounds are used in propane applications, do not use pipe joint compounds on flare fittings).

Step 9. Attach the conversion label provided in the conversion kit to the rating plate on the appliance.

Step 10. Turn on gas supply and test for gas leaks.

NOTE: DIAGRAMS & ILLUSTRATIONS ARE NOT TO SCALE.

Lennox reserves the right to make changes at any time, without notice, in design, materials, specifications, prices and also to discontinue colors, styles and products. Consult your local distributor for fireplace code information.



HEARTH PRODUCTS

1110 West Taft Avenue • Orange, CA 92865