

lenovo

ThinkStation D30
Hardware Maintenance Manual

ThinkThink**ThinkStation**Think

Machine Types: 4353 and 4354

Note: Before using this information and the product it supports, be sure to read and understand the Chapter 2 “Safety information” on page 3 and Appendix A “Notices” on page 133.

Sixth Edition (June 2014)

© Copyright Lenovo 2012, 2014.

LIMITED AND RESTRICTED RIGHTS NOTICE: If data or software is delivered pursuant a General Services Administration “GSA” contract, use, reproduction, or disclosure is subject to restrictions set forth in Contract No. GS-35F-05925.

Contents

Chapter 1. About this manual 1

Important Safety Information 1

Chapter 2. Safety information 3

General safety 3

Electrical safety 3

Safety inspection guide 5

Handling electrostatic discharge-sensitive devices 5

Grounding requirements 6

Safety notices (multi-lingual translations) 6

Chapter 3. General information 29

Specifications 29

Software overview 29

 Accessing Lenovo programs on the Windows 7 operating system 30

 Accessing Lenovo programs on the Windows 8 or Windows 8.1 operating system 30

Lenovo Support Web site 31

Chapter 4. General Checkout 33

Problem determination tips 33

Chapter 5. Troubleshooting and diagnostics 35

Basic troubleshooting 35

Accessing Control Panel on the Windows 8 or Windows 8.1 operating system 36

Troubleshooting procedure 36

Troubleshooting 37

 Audio problems 37

 CD problems 39

 DVD problems 40

 Intermittent problems 41

 Hard disk drive problems 41

 Keyboard, mouse, or pointing device problems 42

 Monitor problems 44

 Networking problems 46

 Option problems 48

 Performance and lockup problems 48

 Printer problems 50

 Serial port problems 51

 Software problems 51

 USB problems 52

Diagnostics 52

 Lenovo Solution Center 53

UEFI diagnostic program 53

Chapter 6. Using the Setup Utility program 55

Starting the Setup Utility program 55

Viewing and changing settings 55

Using passwords 55

 Password considerations 56

 Power-On Password 56

 Administrator Password 56

 Hard Disk Password 56

 Setting, changing, and deleting a password 56

 Erasing lost or forgotten passwords (clearing CMOS) 57

Enabling or disabling a device 57

Selecting a startup device 57

 Selecting a temporary startup device 58

 Selecting or changing the startup device sequence 58

Enabling ErP LPS compliance mode and Deep Sx 58

Changing the BIOS settings before installing a new operating system 59

Exiting the Setup Utility program 59

Chapter 7. Configuring RAID 61

Configuring RAID with Intel RSTe 61

 Installing SATA or SAS hard disk drives 61

 Configuring SATA or SAS RAID functionality with the Intel RSTe configuration utility 62

Quick RAID setup using the LSI MegaRAID BIOS configuration utility 63

 Installing SATA or SAS hard disk drives 64

 Entering the LSI MegaRAID BIOS configuration utility 65

 Creating RAID volumes using the LSI MegaRAID BIOS configuration utility 65

 Deleting RAID volumes using the LSI MegaRAID BIOS configuration utility 66

 Setting the hot spare hard disk drive 66

Chapter 8. Symptom-to-FRU Index 67

Hard disk drive boot error 67

Power Supply Problems 67

Beep symptoms 67

POST error codes 68

Miscellaneous error messages 69

Undetermined problems 71

Chapter 9. Locations 73

Locating connectors, controls, and indicators on the front of your computer 73

Locating connectors on the rear of your computer 74

Locating major FRUs and CRUs 74

Looking up FRU information 76

Locating parts on the system board 76

Locating internal drives 79

Chapter 10. Replacing FRUs 81

Handling static-sensitive devices 81

Installing or replacing hardware 81

 Installing external options 81

 Removing the computer cover. 82

 Removing and reinstalling the front bezel 83

 Installing or replacing a PCI card 84

 Installing or replacing an mSATA solid-state drive 87

 Installing or replacing a memory module. 89

 Installing or replacing the optical drive 92

 Replacing the card reader 95

 Replacing the battery 97

 Replacing the heat sink and fan assembly 98

 Replacing the hard disk drive fan assembly 100

 Replacing the rear fan assembly 101

 Installing or replacing a hard disk drive 103

 Installing or replacing a hard disk drive enablement module 107

 Replacing the front audio and USB assembly 108

Replacing the internal speaker. 109

Installing or replacing the microprocessor 110

Replacing the system board 119

Replacing the power supply assembly 123

Completing the parts replacement 124

Chapter 11. Additional service information 127

Security features 127

 Hardware-controlled passwords 127

 Operating system password 127

 Vital product data. 127

BIOS levels 127

Updating (flashing) the BIOS 127

 Updating (flashing) the BIOS from a disc. 128

 Updating (flashing) the BIOS from your operating system 129

Recovering from a POST/BIOS update failure 129

Power management 129

 Advanced configuration and power interface (ACPI) BIOS 130

 Automatic Power-On features 130

System memory speed 130

Appendix A. Notices. 133

Television output notice 134

European conformance CE mark 134

Trademarks 134

Index. 135

Chapter 1. About this manual

This manual provides service and reference information for ThinkStation® computers listed on the front cover. This manual is intended only for trained service personnel who are familiar with Lenovo® computer products.

Before servicing a Lenovo computer product, be sure to read Chapter 2 “Safety information” on page 3.

Chapter 8 “Symptom-to-FRU Index” on page 67 and Chapter 11 “Additional service information” on page 127 are not specific to any machine type. These chapters are applicable to all ThinkStation computers.

For major Field Replaceable Unit (FRU) locations and Customer Replaceable Unit (CRU) identification, see Chapter 9 “Locations” on page 73.

For FRU replacement instructions, see Chapter 10 “Replacing FRUs” on page 81.

For FRU part numbers, go to:
<http://www.lenovo.com/serviceparts-lookup>

Important Safety Information

Be sure to read all caution and danger statements in this book before performing any of the instructions.

Veillez lire toutes les consignes de type DANGER et ATTENTION du présent document avant d'exécuter les instructions.

Lesen Sie unbedingt alle Hinweise vom Typ "ACHTUNG" oder "VORSICHT" in dieser Dokumentation, bevor Sie irgendwelche Vorgänge durchführen

Leggere le istruzioni introdotte da ATTENZIONE e PERICOLO presenti nel manuale prima di eseguire una qualsiasi delle istruzioni

Certifique-se de ler todas as instruções de cuidado e perigo neste manual antes de executar qualquer uma das instruções

Es importante que lea todas las declaraciones de precaución y de peligro de este manual antes de seguir las instrucciones.

تأكد من قراءة كل التحذيرات الموجودة في هذا الكتاب قبل اتباع هذه التعليمات .

执行任何说明之前，请确保已阅读本书中的所有警告和危险声明。

執行任何指示前，請確實閱讀本書中的所有警告及危險聲明。

ודאו שקראתם את כל הודעות האזהרה והסכנה במסמך זה לפני שתבצעו פעולה כלשהי.

본 사용 설명서에 기재된 내용을 실행하기 전에 모든 주의사항 및 위험사항을 숙지하십시오.

Chapter 2. Safety information

This chapter contains the safety information that you need to be familiar with before servicing a computer.

General safety

Follow these rules to ensure general safety:

- Observe good housekeeping in the area of the machines during and after maintenance.
- When lifting any heavy object:
 1. Ensure you can stand safely without slipping.
 2. Distribute the weight of the object equally between your feet.
 3. Use a slow lifting force. Never move suddenly or twist when you attempt to lift.
 4. Lift by standing or by pushing up with your leg muscles; this action removes the strain from the muscles in your back. *Do not attempt to lift any objects that weigh more than 16 kg (35 lb) or objects that you think are too heavy for you.*
- Do not perform any action that causes hazards to the customer, or that makes the equipment unsafe.
- Before you start the machine, ensure that other service representatives and the customer's personnel are not in a hazardous position.
- Place removed covers and other parts in a safe place, away from all personnel, while you are servicing the machine.
- Keep your tool case away from walk areas so that other people will not trip over it.
- Do not wear loose clothing that can be trapped in the moving parts of a machine. Ensure that your sleeves are fastened or rolled up above your elbows. If your hair is long, fasten it.
- Insert the ends of your necktie or scarf inside clothing or fasten it with a nonconductive clip, approximately 8 centimeters (3 inches) from the end.
- Do not wear jewelry, chains, metal-frame eyeglasses, or metal fasteners for your clothing.
Remember: Metal objects are good electrical conductors.
- Wear safety glasses when you are: hammering, drilling, soldering, cutting wire, attaching springs, using solvents, or working in any other conditions that might be hazardous to your eyes.
- After service, reinstall all safety shields, guards, labels, and ground wires. Replace any safety device that is worn or defective.
- Reinstall all covers correctly before returning the machine to the customer.

Electrical safety



CAUTION:

Electrical current from power, telephone, and communication cables can be hazardous. To avoid personal injury or equipment damage, disconnect the attached power cords, telecommunication systems, networks, and modems before you open the server/workstation covers, unless instructed otherwise in the installation and configuration procedures.

Observe the following rules when working on electrical equipment.

Important: Use only approved tools and test equipment. Some hand tools have handles covered with a soft material that does not insulate you when working with live electrical currents. Many customers have, near their equipment, rubber floor mats that contain small conductive fibers to decrease electrostatic discharges. Do not use this type of mat to protect yourself from an electric shock.

- Find the room emergency power-off (EPO) switch, disconnecting switch, or electrical outlet. If an electrical accident occurs, you can then operate the switch or unplug the power cord quickly.
- Do not work alone under hazardous conditions or near equipment that has hazardous voltages.
- Disconnect all power before:
 - Performing a mechanical inspection
 - Working near power supplies
 - Removing or installing FRU
- Before you start to work on the machine, unplug the power cord. If you cannot unplug it, ask the customer to power-off the wall box that supplies power to the machine and to lock the wall box in the off position.
- If you need to work on a machine that has exposed electrical circuits, observe the following precautions:
 - Ensure that another person, familiar with the power-off controls, is near you.
Remember: Another person must be there to switch off the power, if necessary.
 - Use only one hand when working with powered-on electrical equipment; keep the other hand in your pocket or behind your back.
Remember: There must be a complete circuit to cause an electric shock. By observing the above rule, you may prevent a current from passing through your body.
 - When using a tester, set the controls correctly and use the approved probe leads and accessories for that tester.
 - Stand on suitable rubber mats (obtained locally, if necessary) to insulate you from grounds such as metal floor strips and machine frames.

Observe the special safety precautions when you work with very high voltages; these instructions are in the safety sections of maintenance information. Use extreme care when measuring high voltages.

- Regularly inspect and maintain your electrical hand tools for safe operational condition.
- Do not use worn or broken tools and testers.
- *Never assume* that power has been disconnected from a circuit. First, *check* that it has been powered-off.
- Always look carefully for possible hazards in your work area. Examples of these hazards are moist floors, nongrounded power extension cables, power surges, and missing safety grounds.
- Do not touch live electrical circuits with the reflective surface of a plastic dental mirror. The surface is conductive; such touching can cause personal injury and machine damage.
- Do not service the following parts with the power on when they are removed from their normal operating places in a machine:
 - Power supply units
 - Pumps
 - Blowers and fans
 - Motor generatorsand similar units. (This practice ensures correct grounding of the units.)
- If an electrical accident occurs:
 - Use caution; do not become a victim yourself.
 - Switch off power.
 - Send another person to get medical aid.

Safety inspection guide

The intent of this inspection guide is to assist you in identifying potentially unsafe conditions on these products. Each machine, as it was designed and built, had required safety items installed to protect users and service personnel from injury. This guide addresses only those items. However, good judgment should be used to identify potential safety hazards due to attachment of features or options not covered by this inspection guide.

If any unsafe conditions are present, you must determine how serious the apparent hazard could be and whether you can continue without first correcting the problem.

Consider these conditions and the safety hazards they present:

- Electrical hazards, especially primary power (primary voltage on the frame can cause serious or fatal electrical shock).
- Explosive hazards, such as a damaged CRT face or bulging capacitor
- Mechanical hazards, such as loose or missing hardware

The guide consists of a series of steps presented in a checklist. Begin the checks with the power off, and the power cord disconnected.

Checklist:

1. Check exterior covers for damage (loose, broken, or sharp edges).
2. Power-off the computer. Disconnect the power cord.
3. Check the power cord for:
 - a. A third-wire ground connector in good condition. Use a meter to measure third-wire ground continuity for 0.1 ohm or less between the external ground pin and frame ground.
 - b. The power cord should be the appropriate type as specified in the parts listings.
 - c. Insulation must not be frayed or worn.
4. Remove the cover.
5. Check for any obvious alterations. Use good judgment as to the safety of any alterations.
6. Check inside the unit for any obvious unsafe conditions, such as metal filings, contamination, water or other liquids, or signs of fire or smoke damage.
7. Check for worn, frayed, or pinched cables.
8. Check that the power-supply cover fasteners (screws or rivets) have not been removed or tampered with.

Handling electrostatic discharge-sensitive devices

Any computer part containing transistors or integrated circuits (ICs) should be considered sensitive to electrostatic discharge (ESD). ESD damage can occur when there is a difference in charge between objects. Protect against ESD damage by equalizing the charge so that the machine, the part, the work mat, and the person handling the part are all at the same charge.

Notes:

1. Use product-specific ESD procedures when they exceed the requirements noted here.
2. Make sure that the ESD protective devices you use have been certified (ISO 9000) as fully effective.

When handling ESD-sensitive parts:

- Keep the parts in protective packages until they are inserted into the product.
- Avoid contact with other people while handling the part.

- Wear a grounded wrist strap against your skin to eliminate static on your body.
- Prevent the part from touching your clothing. Most clothing is insulative and retains a charge even when you are wearing a wrist strap.
- Use the black side of a grounded work mat to provide a static-free work surface. The mat is especially useful when handling ESD-sensitive devices.
- Select a grounding system, such as those listed below, to provide protection that meets the specific service requirement.

Note: The use of a grounding system is desirable but not required to protect against ESD damage.

- Attach the ESD ground clip to any frame ground, ground braid, or green-wire ground.
- Use an ESD common ground or reference point when working on a double-insulated or battery-operated system. You can use coax or connector-outside shells on these systems.
- Use the round ground-prong of the ac plug on ac-operated computers.

Grounding requirements

Electrical grounding of the computer is required for operator safety and correct system function. Proper grounding of the electrical outlet can be verified by a certified electrician.

Safety notices (multi-lingual translations)

The caution and danger safety notices in this section are provided in the following languages:

- English
- Arabic
- Brazilian/Portuguese
- Chinese (simplified)
- Chinese (traditional)
- French
- German
- Hebrew
- Italian
- Korean
- Spanish



DANGER

Electrical current from power, telephone and communication cables is hazardous.

To avoid a shock hazard:

- **Do not connect or disconnect any cables or perform installation, maintenance, or reconfiguration of this product during an electrical storm.**
- **Connect all power cords to a properly wired and grounded electrical outlet.**

- Connect to properly wired outlets any equipment that will be attached to this product.
- When possible, use one hand only to connect or disconnect signal cables.
- Never turn on any equipment when there is evidence of fire, water, or structural damage.
- Disconnect the attached power cords, telecommunications systems, networks, and modems before you open the device covers, unless instructed otherwise in the installation and configuration procedures.
- Connect and disconnect cables as described in the following tables when installing, moving, or opening covers on this product or attached devices.

To Connect	To Disconnect
<ol style="list-style-type: none"> 1. Turn everything OFF. 2. First, attach all cables to devices. 3. Attach signal cables to connectors. 4. Attach power cords to outlet. 5. Turn device ON. 	<ol style="list-style-type: none"> 1. Turn everything OFF. 2. First, remove power cords from outlet. 3. Remove signal cables from connectors. 4. Remove all cables from devices.



CAUTION:

When replacing the lithium battery, use only Part Number 45C1566 or an equivalent type battery recommended by the manufacturer. If your system has a module containing a lithium battery, replace it only with the same module type made by the same manufacturer. The battery contains lithium and can explode if not properly used, handled, or disposed of. *Do not:*

- Throw or immerse into water
- Heat to more than 100°C (212°F)
- Repair or disassemble

Dispose of the battery as required by local ordinances or regulations.



CAUTION:

When laser products (such as CD-ROMs, DVD-ROM drives, fiber optic devices, or transmitters) are installed, note the following:

- Do not remove the covers. Removing the covers of the laser product could result in exposure to hazardous laser radiation. There are no serviceable parts inside the device.
- Use of controls or adjustments or performance of procedures other than those specified herein might result in hazardous radiation exposure.



DANGER

Some laser products contain an embedded Class 3A or Class 3B laser diode. Note the following:

Laser radiation when open. Do not stare into the beam, do not view directly with optical instruments, and avoid direct exposure to the beam.



≥18 kg (37 lbs)



≥32 kg (70.5 lbs)

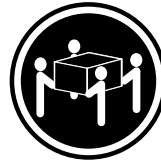

≥55 kg (121.2 lbs)

CAUTION:

Use safe practices when lifting.



CAUTION:

The power control button on the device and the power switch on the power supply do not turn off the electrical current supplied to the device. The device also might have more than one power cord. To remove all electrical current from the device, ensure that all power cords are disconnected from the power source.



التيار الكهربائي الموجود بمصدر الطاقة أو أجهزة التليفون أو أسلاك الاتصالات يشكل خطورة.

لتفادي مخاطر الصدمات الكهربائية:

لا تحاول توصيل أو فصل أي أسلاك أو القيام بعمليات تركيب أو صيانة أو إعادة توصيف لهذا المنتج أثناء وجود عاصفة كهربائية.

يجب توصيل كل أسلاك الكهرباء في مخارج كهرباء ذات توصيلات أسلاك وتوصيلات أرضية صحيحة
يجب توصيل أي جهاز سيتم الحاقه بهذا المنتج في مخارج كهرباء ذات توصيلات أسلاك صحيحة.

وإن أمكن يجب استخدام يد واحدة فقط في توصيل أو فصل أسلاك الإشارة.

لا تحاول تشغيل أي جهاز إذا كان هناك أثر لحرق أو مياه أو تلف بالمكونات

يجب فصل أسلاك الكهرباء وأنظمة الاتصالات وشبكات الاتصال وأجهزة المودم الملحقة قبل فتح أغطية الجهاز، مالم يتم طلب خلاف ذلك في التعليمات الخاصة بالتركيب والتوصيف.
قم بتوصيل وفصل الأسلاك كما هو موضح في الجدول التالي وذلك عند القيام بعمليات التركيب أو النقل أو فتح أغطية هذا المنتج أو الأجهزة الملحقة.

للفصل:

- قم بإيقاف كل شيء.
- أولاً، قم بفصل كل أسلاك الكهرباء من المخرج.
- قم بفصل أسلاك الإشارة من الموصلات.
- قم بفصل كل الأسلاك من الأجهزة.

للتوصيل:

- قم بإيقاف كل شيء.
- أولاً، قم بتوصيل كل الأسلاك بالأجهزة.
- قم بتوصيل أسلاك الإشارة في لموصلات.
- قم بتوصيل أسلاك الكهرباء في المخارج.
- قم بتشغيل الجهاز.



تنبيه:

عند استبدال البطارية الليثيوم، استخدم فقط رقم الجزء الخاص **Part Number 45C1566**

أو نوع آخر يكون على نفس مستوى الكفاءة يحدده لك المصنع.

إذا كان النظام الخاص يستخدم معه بطارية ليثيوم قم باستبدالها بنفس النوع الذي تم صناعته من خلال نفس المصنع. تحتوي البطارية على مادة الليثيوم ويمكن أن تنفجر في حالة عدم استخدامها أو التعامل معها بطريقة صحيحة أو عند التخلص منها بطريقة خطأ.

لا تقم بـ:

- القاء البطارية أو غمرها في الماء
- تسخينها أعلى من ١٠٠ درجة مئوية و(٢١٢ ° فهرنهايت)
- بتصليحها أو فكها

تخلص من البطارية طبقاً للقانون أو النظام المحلي .



تنبيهه :
أثناء تركيب منتجات ليزر (مثل CD-ROMs أو وحدة تشغيل DVD أو أجهزة Fiber Optic أو وحدات الإرسال) يجب مراعاة الآتي:

لا تنزع الأغطية. قد ينتج عن نزع أغطية منتج الليزر انفجار أشعة الليزر شديدة الخطورة.
لا يوجد أجزاء يمكن تغييرها داخل الجهاز. قد ينتج عن استخدام تحكيمات أو تعديلات أو عمل أي تصرفات أخرى تخالف ما هو محدد هنا إلى انفجار أشعة شديدة الخطورة.



خطر

تحتوي بعض منتجات الليزر على الفئة دايود ليزر مدمج من الفئة Class 3A أو Class 3B. يجب مراعاة الآتي .

أشعة الليزر عند الفتح. لا تحدد إلى الإشعاع و لا تنظر إليه مباشرة بواسطة أي أجهزة مرئية وتجنب التعرض المباشر للإشعاع .



≥18 kg (37 lbs)



≥32 kg (70.5 lbs)

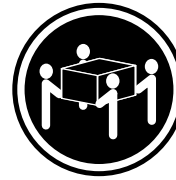

≥55 kg (121.2 lbs)

تنبيهه :
يجب استخدام ممارسات أمانة عند الرفع



تنبيهه :
لا يقرم زر التحكم في التشغيل الموجود على الجهاز والمفتاح الكهربائي الموجود على لوحة التحكم بإيقاف التيار الكهربائي المار بالجهاز. قد يكون للجهاز أكثر من سلك كهربائي واحد. لإيقاف التيار الكهربائي المار بالجهاز، تأكد من فصل جميع أسلاك الكهرباء من مصدر الكهرباء .

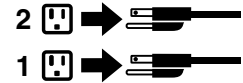

PERIGO

A corrente elétrica proveniente de cabos de alimentação, de telefone e de comunicações é perigosa.

Para evitar risco de choque elétrico:

- Não conecte nem desconecte nenhum cabo ou execute instalação, manutenção ou reconfiguração deste produto durante uma tempestade com raios.
- Conecte todos os cabos de alimentação a tomadas elétricas corretamente instaladas e aterradas.
- Todo equipamento que for conectado a este produto deve ser conectado a tomadas corretamente instaladas.
- Quando possível, utilize apenas uma das mãos para conectar ou desconectar cabos de sinal.
- Nunca ligue nenhum equipamento quando houver evidência de fogo, água ou danos estruturais.
- Antes de abrir tampas de dispositivos, desconecte cabos de alimentação, sistemas de telecomunicação, redes e modems conectados, a menos que especificado de maneira diferente nos procedimentos de instalação e configuração.
- Conecte e desconecte os cabos conforme descrito na tabela apresentada a seguir ao instalar, mover ou abrir tampas deste produto ou de dispositivos conectados.

Para Conectar:	Para Desconectar:
<ol style="list-style-type: none">1. DESLIGUE Tudo.2. Primeiramente, conecte todos os cabos aos dispositivos.3. Conecte os cabos de sinal aos conectores.4. Conecte os cabos de alimentação às tomadas.5. LIGUE os dispositivos.	<ol style="list-style-type: none">1. DESLIGUE Tudo.2. Primeiramente, remova os cabos de alimentação das tomadas.3. Remova os cabos de sinal dos conectores.4. Remova todos os cabos dos dispositivos.



CUIDADO:

Ao substituir a bateria de lítio, utilize apenas uma bateria com Número de Peça 45C1566 ou um tipo de bateria equivalente recomendado pelo Se o seu sistema possui um módulo com uma bateria de lítio, substitua-o apenas por um módulo do mesmo tipo e do mesmo fabricante. A bateria contém lítio e pode explodir se não for utilizada, manuseada ou descartada de maneira correta.

Não:

- Jogue ou coloque na água
- Aqueça a mais de 100°C (212°F)
- Conserte nem desmonte

Descarte a bateria conforme requerido pelas leis ou regulamentos locais.



PRECAUCIÓN:

Quando produtos a laser (como unidades de CD-ROMs, unidades de DVD-ROM, dispositivos de fibra ótica ou transmissores) estiverem instalados, observe o seguinte:

- Não remova as tampas. A remoção das tampas de um produto a laser pode resultar em exposição prejudicial à radiação de laser. Não existem peças que podem ser consertadas no interior do dispositivo.

- A utilização de controles ou ajustes ou a execução de procedimentos diferentes dos especificados aqui pode resultar em exposição prejudicial à radiação.

PERIGO

Alguns produtos a laser contêm diodo de laser integrado da Classe 3A ou da Classe 3B. Observe o seguinte:

Radiação a laser quando aberto. Não olhe diretamente para o feixe a olho nu ou com instrumentos ópticos e evite exposição direta ao feixe.



≥18 kg (37 lbs)



≥32 kg (70.5 lbs)

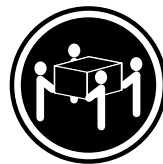

≥55 kg (121.2 lbs)

CUIDADO:

Utilize procedimentos de segurança para levantar equipamentos.



CUIDADO:

O botão de controle de alimentação do dispositivo e o botão para ligar/desligar da fonte de alimentação não desligam a corrente elétrica fornecida ao dispositivo. O dispositivo também pode ter mais de um cabo de alimentação. Para remover toda a corrente elétrica do dispositivo, assegure que todos os cabos de alimentação estejam desconectados da fonte de alimentação.

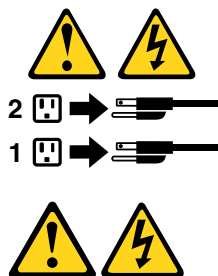

危险

电源、电话和通信电缆中的电流是危险的。

为避免电击危险：

- 请勿在雷电期间连接或断开任何电缆的连接，或者对本产品进行安装、维护或重新配置。
- 将所有电源线连接到正确连线和妥善接地的电源插座。
- 将所有要连接到该产品的设备连接到正确连线的插座。
- 如果可能，请仅使用一只手来连接或断开信号电缆的连接。
- 切勿在有火、水、结构损坏迹象的情况下开启任何设备。
- 在打开设备外盖之前请断开已连接的电源线、远程通信系统、网络和调制解调器，除非在安装和配置过程中另有说明。
- 当安装、移动或打开该产品或连接设备的外盖时，请按照下表所述来连接或断开电缆的连接。

要连接	要断开连接
<ol style="list-style-type: none">1. 切断所有电源。2. 首先将所有电缆连接到设备。3. 将信号电缆连接到接口。4. 将电源线连接到插座。5. 开启设备。	<ol style="list-style-type: none">1. 切断所有电源。2. 首先从插座上拔出电源线。3. 从接口上拔出信号电缆。4. 从设备上拔出所有电缆。



警告：

更换锂电池时，请仅使用部件号为 45C1566 的电池或制造商推荐的同类电池。如果您的系统有包含锂电池的模块，请仅使用同一制造商生产的相同模块类型来替换该模块。该电池中含有锂，如果使用、操作或处理不当，可能会发生爆炸。

切勿：

- 投入或浸入水中
- 加热到 100°C (212°F) 以上
- 维修或拆卸

请按照当地法令或条例的要求处理电池。



警告：

安装激光产品（例如 CD-ROM、DVD-ROM 驱动器、光纤设备或发射设备）时，请注意以下声明：

- 请勿卸下外盖。卸下激光产品的外盖可能导致遭受激光辐射的危险。该设备内没有可维修的部件。
- 如果不按照此处指定的过程进行控制、调整或操作，则有可能导致遭受辐射的危险。



危險

某些激光产品包含嵌入式 3A 类或 3B 类激光二极管。请注意以下声明：

打开后有激光辐射。请勿注视光束，请勿直接用光学仪器查看，并请避免直接暴露在光束中。

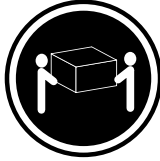

≥18 千克 (37 磅) ≥32 千克 (70.5 磅) ≥55 千克 (121.2 磅)

警告：
抬起时请采取安全措施。



警告：
设备上的电源控制按钮和电源上的电源开关不会切断供给该设备的电流。该设备还可能有多条电源线。要切断该设备的所有电流，请确保所有电源线都与电源断开连接。

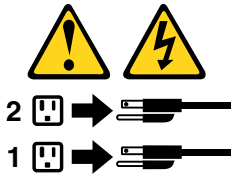

危險

電源、電話及通訊纜線上的電流都具有危險性。

若要避免觸電危險：

- 請勿在雷雨期間，連接或拔除纜線、執行安裝、維護或重新配置本產品。
- 將所有電源線連接到正確配線及接地的電源插座。
- 任何與本產品連接的設備都必須連接到配線妥當的電源插座。
- 請盡可能用單手連接或拔除信號線。
- 發生火災、水災或結構損害時，絕對不要開啟任何設備。
- 除非在安裝及配置程序中另有指示，否則在開啟裝置機蓋之前，請拔掉連接的電源線、電信系統、網路及數據機。
- 安裝、移動或開啟本產品或附屬裝置的機蓋時，請遵循下列說明連接及拔掉纜線。

連線	切斷連線
<ol style="list-style-type: none"> 1. 關閉所有開關。 2. 首先，連接所有接線到裝置。 3. 連接信號線到接頭。 4. 連接電源線到插座。 5. 開啟裝置。 	<ol style="list-style-type: none"> 1. 關閉所有開關。 2. 首先，拔掉插座上的電源線。 3. 拔掉接頭上的信號線。 4. 拔掉裝置上所有接線。



警告：

更換鋰電池時，請僅使用產品編號 **45C1566** 或製造商所建議的同類型電池。
如果您的系統中含有鋰電池模組，請僅使用同一家製造商所生產的相同模組進行更換。
如果未以正確方式使用、處理或棄置含鋰的電池，會有爆炸的危險。
請勿：

- 沾溼或浸入水中
 - 置於 **100°C (212°F)** 以上的高溫環境
 - 修理或拆開
- 請按照各地區有關廢棄電池的法令和規定處理舊電池。



警告：

- 請勿移除機蓋。移除雷射產品的機蓋，可能會導致暴露在危險的雷射輻射中。裝置內部並無可自行維修的零件。
- 利用或執行非本文中指定的控制、調整及執行程序，可能會導致危險的輻射外洩。



危險

部分雷射產品含有內嵌式 **Class 3A** 或 **Class 3B** 雷射二極體。請注意下列事項：
在開啟光碟機時，會發生雷射輻射。請勿直視光束或用光學儀器直接檢視，並避免直接暴露在光束中。



≥ 18 公斤 (37 磅)

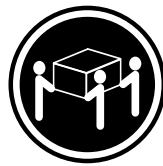

≥ 32 公斤 (70.5 磅)

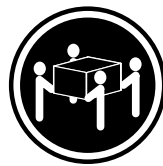

≥ 55 公斤 (121.2 磅)

警告：

搬運時請注意安全。



警告：

裝置上的電源控制按鈕及電源供應器上的電源開關，無法關閉裝置所產生的電流。
該裝置可能有多條電源線。若要除去裝置流出的所有電流，請確認已切斷所有電源線的電源。

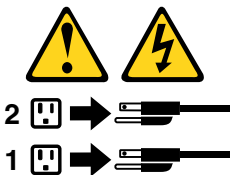

DANGER

Le courant électrique provenant de l'alimentation, du téléphone et des câbles de transmission peut présenter un danger.

Pour éviter tout risque de choc électrique :

- Ne manipulez aucun câble et n'effectuez aucune opération d'installation, d'entretien ou de reconfiguration de ce produit au cours d'un orage.
- Branchez tous les cordons d'alimentation sur un socle de prise de courant correctement câblé et mis à la terre.
- Branchez sur des socles de prise de courant correctement câblés tout équipement connecté à ce produit.
- Lorsque cela est possible, n'utilisez qu'une seule main pour connecter ou déconnecter les câbles d'interface.
- Ne mettez jamais un équipement sous tension en cas d'incendie ou d'inondation, ou en présence de dommages matériels.
- Avant de retirer les carters de l'unité, mettez celle-ci hors tension et déconnectez ses cordons d'alimentation, ainsi que les câbles qui la relient aux réseaux, aux systèmes de télécommunication et aux modems (sauf instruction contraire mentionnée dans les procédures d'installation et de configuration).
- Lorsque vous installez, que vous déplacez, ou que vous manipulez le présent produit ou des périphériques qui lui sont raccordés, reportez-vous aux instructions ci-dessous pour connecter et déconnecter les différents cordons.

Connexion	Déconnexion
<ol style="list-style-type: none">1. Mettez les unités HORS TENSION.2. Commencez par brancher tous les cordons sur les unités.3. Branchez les câbles d'interface sur des connecteurs.4. Branchez les cordons d'alimentation sur des prises.5. Mettez les unités SOUS TENSION.	<ol style="list-style-type: none">1. Mettez les unités HORS TENSION.2. Débranchez les cordons d'alimentation des prises.3. Débranchez les câbles d'interface des connecteurs.4. Débranchez tous les câbles des unités.



ATTENTION:

Remplacer la pile au lithium usagée par une pile de référence identique exclusivement, (référence 45C1566), ou suivre les instructions du fabricant qui en définit les équivalences. Si votre système est doté d'un module contenant une pile au lithium, vous devez le remplacer uniquement par un module identique, produit par le même fabricant. La pile contient du lithium et peut exploser en cas de mauvaise utilisation, de mauvaise manipulation ou de mise au rebut inappropriée.

Ne pas :

- la jeter à l'eau,
- l'exposer à des températures supérieures à 100°C,
- chercher à la réparer ou à la démonter.

Ne pas mettre la pile à la poubelle. Pour la mise au rebut, se reporter à la réglementation en vigueur.



ATTENTION:

Si des produits à laser (tels que des unités de CD-ROM, de DVD-ROM, des unités à fibres optiques, ou des émetteurs) sont installés, prenez connaissance des informations suivantes :

- Ne retirez pas le carter. En ouvrant l'unité de CD-ROM ou de DVD-ROM, vous vous exposez au rayonnement dangereux du laser. Aucune pièce de l'unité n'est réparable.
- Pour éviter tout risque d'exposition au rayon laser, respectez les consignes de réglage et d'utilisation des commandes, ainsi que les procédures décrites dans le présent manuel.



DANGER

Certains produits à laser contiennent une diode à laser intégrée de classe 3A ou 3B. Prenez connaissance des informations suivantes:

Rayonnement laser lorsque le carter est ouvert. Evitez toute exposition directe au rayon laser. Evitez de regarder fixement le faisceau ou de l'observer à l'aide d'instruments optiques.

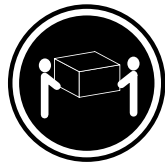

≥18 kg (37 lbs)



≥32 kg (70.5 lbs)

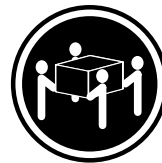

≥55 kg (121.2 lbs)

ATTENTION:

Soulevez la machine avec précaution.



ATTENTION:

L'interrupteur de contrôle d'alimentation de l'unité et l'interrupteur dubloc d'alimentation ne coupent pas le courant électrique alimentant l'unité. En outre, le système peut être équipé de plusieurs cordons d'alimentation. Pour mettre l'unité hors tension, vous devez déconnecter tous les cordons de la source d'alimentation.

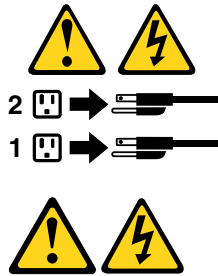

VORSICHT

An Netz-, Telefon- und Datenleitungen können gefährliche Spannungen anliegen.

Aus Sicherheitsgründen:

- Bei Gewitter an diesem Gerät keine Kabel anschließen oder lösen. Ferner keine Installations-, Wartungs- oder Rekonfigurationsarbeiten durchführen.
- Gerät nur an eine Schutzkontaktsteckdose mit ordnungsgemäß geerdetem Schutzkontakt anschließen.
- Alle angeschlossenen Geräte ebenfalls an Schutzkontaktsteckdosen mit ordnungsgemäß geerdetem Schutzkontakt anschließen.
- Die Signalkabel nach Möglichkeit einhändig anschließen oder lösen, um einen Stromschlag durch Berühren von Oberflächen mit unterschiedlichem elektrischem Potenzial zu vermeiden.
- Geräte niemals einschalten, wenn Hinweise auf Feuer, Wasser oder Gebäudeschäden vorliegen.
- Die Verbindung zu den angeschlossenen Netzkabeln, Telekommunikationssystemen, Netzwerken und Modems ist vor dem Öffnen des Gehäuses zu unterbrechen, sofern in den Installations- und Konfigurationsprozeduren keine anders lautenden Anweisungen enthalten sind.
- Zum Installieren, Transportieren und Öffnen der Abdeckungen des Computers oder der angeschlossenen Einheiten die Kabel gemäß der folgenden Tabelle anschließen und abziehen.

Zum Anschließen der Kabel gehen Sie wie folgt vor	Zum Abziehen der Kabel gehen Sie wie folgt vor
<ol style="list-style-type: none"> 1. Schalten Sie alle Einheiten AUS. 2. Schließen Sie erst alle Kabel an die Einheiten an. 3. Schließen Sie die Signalkabel an die Buchsen an. 4. Schließen Sie die Netzkabel an die Steckdose an. 5. Schalten Sie die Einheit EIN. 	<ol style="list-style-type: none"> 1. Schalten Sie alle Einheiten AUS. 2. Ziehen Sie zuerst alle Netzkabel aus den Netzsteckdosen. 3. Ziehen Sie die Signalkabel aus den Buchsen. 4. Ziehen Sie alle Kabel von den Einheiten ab.



CAUTION:

Eine verbrauchte Lithiumbatterie nur durch eine Batterie mit der Teilenummer 45C1566 oder eine gleichwertige, vom Hersteller empfohlene Batterie ersetzen. Enthält das System ein Modul mit einer Lithiumbatterie, dieses nur durch ein Modul desselben Typs und von demselben Hersteller ersetzen. Die Batterie enthält Lithium und kann bei unsachgemäßer Verwendung, Handhabung oder Entsorgung explodieren.

Die Batterie nicht:

- mit Wasser in Berührung bringen.

- über 100 C erhitzen.
- reparieren oder zerlegen.

Die örtlichen Bestimmungen für die Entsorgung von Sondermüll beachten.



ACHTUNG:

Bei der Installation von Lasergeräten (wie CD-ROM-Laufwerken, DVD- aufwerken, Einheiten mit Lichtwellenleitertechnik oder Sendern) Folgendes beachten:

- Die Abdeckungen nicht entfernen. Durch Entfernen der Abdeckungen des Lasergeräts können gefährliche Laserstrahlungen freigesetzt werden. Das Gerät enthält keine zu wartenden Teile.
- Werden Steuerelemente, Einstellungen oder Durchführungen von Prozeduren anders als hier angegeben verwendet, kann gefährliche Laserstrahlung auftreten.



VORSICHT

Einige Lasergeräte enthalten eine Laserdiode der Klasse 3A oder 3B. Beachten Sie Folgendes:

Laserstrahlung bei geöffneter Verkleidung. Nicht in den Strahl blicken. Keine Lupen oder Spiegel verwenden. Strahlungsbereich meiden.



≥18 kg



≥32 kg

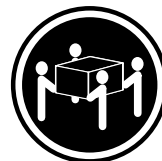

≥55 kg

ACHTUNG:

Arbeitsschutzrichtlinien beim Anheben der Maschine beachten.



ACHTUNG:

Mit dem Netzschalter an der Einheit und am Netzteil wird die Stromversorgung für die Einheit nicht unterbrochen. Die Einheit kann auch mit mehreren Netzkabeln ausgestattet sein. Um die Stromversorgung für die Einheit vollständig zu unterbrechen, müssen alle zum Gerät führenden Netzkabel vom Netz getrennt werden.

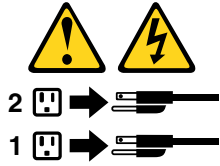

סכנה

זרם חשמלי המועבר בכבלי חשמל, טלפון ותקשורת הוא מסוכן.

כדי להימנע מסכנת התחשמלות:

- אל תחברו או תנתקו כבלים, ואל תבצעו פעולת התקנה, תחזוקה או שינוי תצורה במוצר זה במהלך סופת ברקים.
- חברו את כל כבלי החשמל לשקע חשמל מחווט ומוארק כהלכה.
- חברו כל ציוד שיחובר למוצר זה לשקעי חשמל מחוטים כהלכה.
- במידת האפשר, השתמשו ביד אחת בלבד לחיבור או לניתוק של כבלי אותות.
- לעולם אל תפעילו ציוד כלשהו כאשר יש עדות לנזק מבני או לנזק כתוצאה מאש או ממים.
- נתקו את כבלי החשמל, מערכות התקשורת, התקני הרשת והמודמים המחוברים לפני פתיחת כיסויי ההתקן, אלא אם הליכי ההתקנה וקביעת התצורה מורים אחרת.
- בעת התקנה, העברה או פתיחת כיסויים במוצר זה או בהתקנים המחוברים, חברו ונתקו את הכבלים כמתואר בטבלה שלהלן.

כדי לחבר	כדי לנתק
1. כבו הכל.	1. כבו הכל.
2. ראשית, חברו את כל הכבלים להתקנים.	2. ראשית, נתקו את כבלי החשמל מהשקעים.
3. חברו את כבלי האותות למחברים.	3. נתקו את כבלי האותות מהמחברים.
4. חברו את כבלי החשמל לשקעים.	4. הסירו את כל הכבלים מההתקנים.
5. הפעילו את ההתקן.	



זהירות:

בעת החלפת סוללת סוללת הליתיום, השתמשו רק בסוללה בעלת מק"ט 45C1566 או בסוג תואם שהומלץ על ידי היצרן. אם המערכת כוללת מודול המכיל סוללת ליתיום, החליפו אותה רק במודול מאותו סוג ומתוצרת אותו יצרן. הסוללה מכילה ליתיום, ועלולה להתפוצץ אם לא משתמשים ומטפלים בה או משליכים אותה כיארות.

לעולם:

- אל תטבלו במים
- אל תחממו לטמפרטורה הגבוהה מ-100°C (212°F)
- אל תתקנו או תפרקו
- השליכו את הסוללה כנדרש לפי התקנות והחוקים המקומיים.



זהירות:

בעת התקנת מוצרי ליזר (כגון כונני תקליטורים ו-DVD, התקני סיב אופטי או משדרים), שימו לב לאזהרות הבאות:

- אל תסירו את הכיסויים. הסרת הכיסויים של מוצר הלייזר עלולה לגרום לחשיפה לקרינת לייזר מסוכנת. אין חלקים ברי טיפול בתוך ההתקן.
- שינויים, שימוש בבקרות או ביצוע הליכים אחרים מאלה המתוארים כאן, עלולים לגרום לחשיפה לקרינה מסוכנת.



סכנה

מוצרי לייזר מסוימים מכילים דיודת לייזר מסוג Class 3A או Class 3B. שימו לב לאזהרה הבאה:
כאשר הוא פתוח, המוצר פולט קרינת לייזר. אל תביטו ישירות בקרן, אל תביטו ישירות בעזרת ציוד אופטי, והימנעו מחשיפה לקרן.

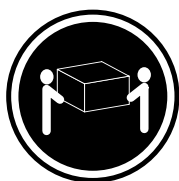

≤ 18 ק"ג (37 ליב')



≤ 32 ק"ג (70.5 ליב')

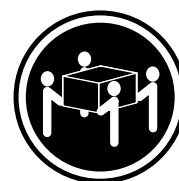

≤ 55 ק"ג (121.2 ליב')

זהירות:
השתמשו בהליכים הנאותים בעת הרמת הציוד.



זהירות:

לחצן ההפעלה של ההתקן ומתג ההפעלה של ספק החשמל אינם מפסיקים את זרם החשמל המסופק להתקן. בנוסף, ההתקן עשוי לכלול יותר מכבל חשמל אחד. כדי לסלק את כל הזרם החשמלי מההתקן, ודאו שכל כבלי החשמל מנותקים ממקור החשמל.

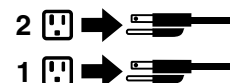



PERICOLO

La corrente elettrica proveniente dai cavi di alimentazione, del telefono e di comunicazione può essere pericolosa.

Per evitare il rischio di scosse elettriche:

- **Non collegare o scollegare qualsiasi cavo oppure effettuare l'installazione, la manutenzione o la riconfigurazione del prodotto durante un temporale.**
- **Collegare tutti i fili elettrici a una presa di alimentazione correttamente cablata e dotata di messa a terra.**
- **Collegare alle prese elettriche appropriate tutte le apparecchiature che verranno utilizzate per questo prodotto.**
- **Se possibile, utilizzare solo una mano per collegare o scollegare i cavi di segnale.**
- **Non accendere assolutamente apparecchiature in presenza di incendi, perdite d'acqua o danno strutturale.**
- **Scollegare i cavi di alimentazione, i sistemi di telecomunicazione, le reti e il modem prima di aprire i coperchi del dispositivo, salvo istruzioni contrarie relative alle procedure di installazione e configurazione.**
- **Collegare e scollegare i cavi come descritto nella seguente tabella quando vengono effettuate operazioni di installazione, spostamento o apertura dei coperchi di questo prodotto o delle unità collegate.**

Per collegarsi	Per scollegarsi
<ol style="list-style-type: none">1. SPEGNERE le apparecchiature.2. Innanzitutto, collegare tutti i cavi alle unità.3. Collegare i cavi di segnale ai connettori.4. Collegare i cavi di alimentazione alla presa.5. Accendere l'unità.	<ol style="list-style-type: none">1. SPEGNERE le apparecchiature.2. Innanzitutto, rimuovere i cavi di alimentazione dalla presa.3. Rimuovere i cavi di segnale dai connettori.4. Rimuovere tutti i cavi dalle unità.



ATTENZIONE:

Quando si sostituisce la batteria al litio, utilizzare solo il Numero parte 45C1566 o un tipo di batteria equivalente consigliato dal produttore. Se sul sistema è presente un modulo che contiene una batteria al litio, sostituirlo solo con un tipo di modulo dello stesso tipo della stessa casa di produzione. La batteria contiene litio e può esplodere se usata, maneggiata o smaltita in modo non corretto.

Non:

- **Gettare o immergere la batteria nell'acqua**
- **Riscaldarla ad una temperatura superiore ai 100 gradi C (212 gradi F)**
- **Smontarla, ricaricarla o tentare di ripararla**

Le batterie usate vanno smaltite in accordo alla normativa in vigore (DPR 915/82 e successive disposizioni e disposizioni locali).



ATTENZIONE:

Quando vengono installati prodotti laser (quali CD-ROM, unità DVD-ROM, unità a fibre ottiche o trasmettenti), tener presente quanto segue:

- Non rimuovere gli sportelli. L'apertura di un'unità laser può determinare l'esposizione a radiazioni laser pericolose. All'interno dell'unità non vi sono parti su cui effettuare l'assistenza tecnica.
- L'utilizzo di controlli, regolazioni o l'esecuzione di procedure non descritti nel presente manuale possono provocare l'esposizione a radiazioni pericolose.



PERICOLO

Alcune unità laser contengono un diodo laser di Classe 3A o Classe 3B. Tener presente quanto segue:

Aperto l'unità vengono emesse radiazioni laser. Non fissare il fascio, non guardarlo direttamente con strumenti ottici ed evitare l'esposizione al fascio.



≥18 kg



≥32 kg

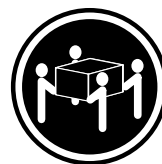

≥55 kg

ATTENZIONE:

Prestare attenzione nel sollevare l'apparecchiatura.



ATTENZIONE:

Il pulsante di controllo dell'alimentazione presente sull'unità e l'interruttore dell'alimentatore non disattivano l'alimentazione corrente fornita all'unità. E' possibile che l'unità disponga di più cavi di alimentazione. Per disattivare l'alimentazione dall'unità, accertarsi che tutti i cavi di alimentazione siano scollegati dalla fonte di alimentazione.

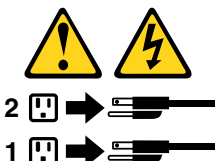



위험

전원, 전화, 통신 케이블의 전류는 위험합니다.

감전의 위험을 피하려면 다음과 같이 하십시오.

- 번개가 치는 날에는 케이블을 연결 또는 분리하거나 본 제품을 설치, 보수, 재구성하지 마십시오.
- 모든 전원 코드는 올바르게 접지된 전기 콘센트에 연결하십시오.
- 본 제품에 연결될 장치는 올바르게 배선된 콘센트에 연결하십시오.
- 신호 케이블을 연결 또는 분리할 때 가능하면 한 손만을 사용하십시오.
- 불 또는 물로 인한 손상이나 구조적인 손상이 있을 경우 장치의 전원을 절대 켜지 마십시오.
- 설치 및 구성 과정에 별도의 지시 사항이 없는 경우, 장치의 덮개를 열기 전에 연결된 전원 코드, 원격 통신 시스템, 네트워크, 모뎀을 분리하십시오.
- 본 제품이나 연결된 장치를 설치, 이동하거나 덮개를 열 때 다음 표와 같은 순서로 케이블을 연결하거나 분리하십시오.

연결할 때:	분리할 때:
<ol style="list-style-type: none"> 1. 모든 장치의 전원을 끄십시오. 2. 먼저 모든 케이블을 장치에 연결하십시오. 3. 커넥터에 신호 케이블을 연결하십시오. 4. 콘센트에 전원 코드를 연결하십시오. 5. 장치의 전원을 켜십시오. 	<ol style="list-style-type: none"> 1. 모든 장치의 전원을 끄십시오. 2. 먼저 콘센트에서 전원 코드를 분리하십시오. 3. 커넥터에서 신호 케이블을 분리하십시오. 4. 장치에서 모든 케이블을 분리하십시오.



주의:

배터리를 교환할 때는 Part Number 45C1566 또는 제조업체에서 지정한 동일한 종류의 제품을 사용하십시오. 사용자의 시스템이 리튬 배터리를 포함하는 모듈일 경우, 동일한 제조업체에서 동일한 모듈 유형으로 생산된 제품으로 교체하십시오. 배터리에는 리튬이 함유되어 있어 잘못 사용, 취급 또는 폐기할 경우 폭발의 위험이 있습니다.

사고를 방지하려면 다음 사항을 준수하십시오.

- 배터리를 물 속에 던지거나 침수시키지 마십시오.
- 100°C (212°F) 이상 가열하지 마십시오.
- 수리하거나 분해하지 마십시오.

배터리를 폐기할 때는 법령 또는 회사의 안전 수칙에 따라 폐기하십시오.



주의:

CD-ROM, DVD-ROM 장치, 광섬유 장치 또는 송신 장치와 같은 레이저 제품을 설치할 때, 다음과 같은 취급 주의사항을 참고하십시오.

- 덮개를 열지 마십시오. 덮개를 열면 레이저 복사 에너지에 노출될 위험이 있습니다. 장치 내부에는 사용자가 조정하거나 수리할 수 있는 부품이 없습니다.
- 규정된 것 이외의 절차 수행, 제어 조정 등의 행위로 인해 해로운 레이저 복사에 노출될 수 있습니다.



위험

일부 장비에는 임베디드 클래스 3A 또는 클래스 3B 레이저 다이오드가 있습니다. 다음 주의사항에 유의하십시오.

드라이브가 열리면 레이저 복사 에너지가 방출됩니다. 광선이 눈에 직접 쏘이지 않도록 하십시오. 나안 또는 광학 기구를 착용한 상태에서 광선을 직접 바라보지 않도록 하십시오.



≥ 18 kg (37 lbs)



≥ 32 kg (70.5 lbs)



≥ 55 kg (121.2 lbs)

주의:
제품을 들어 올릴 때
안전 규제를 따르십시오.



주의:
장치의 전원 제어 버튼 및 전원 공급 장치의 전원 스위치를 사용하여 장치에 공급되는 전기를 차단하지 마십시오.
장치는 둘 이상의 코드를 가지고 있을 수 있습니다. 장치에서 모든 전원을 차단하려면 콘센트에서 코드가 모두 분리되어 있는지 확인하십시오.

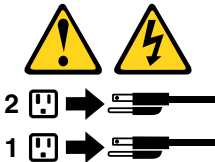

PELIGRO

La corriente eléctrica procedente de cables de alimentación, teléfonos y cables de comunicación puede ser peligrosa.

Para evitar el riesgo de descarga eléctrica:

- No conecte ni desconecte los cables ni realice ninguna tarea de instalación, mantenimiento o reconfiguración de este producto durante una tormenta eléctrica.
- Conecte todos los cables de alimentación a tomas de corriente debidamente cableadas y conectadas a tierra.
- Cualquier equipo que se conecte a este producto también debe conectarse a tomas de corriente debidamente cableadas.
- Siempre que sea posible, utilice una sola mano para conectar o desconectar los cables de señal.

- No encienda nunca un equipo cuando hay señales de fuego, agua o daños estructurales.
- Desconecte los cables de alimentación, los sistemas de telecomunicaciones, las redes y los módems conectados antes de abrir las cubiertas de los dispositivos, a menos que se indique lo contrario en los procedimientos de instalación y configuración.
- Conecte y desconecte los cables, como se describe en la tabla siguiente, cuando instale, mueva o abra las cubiertas de este producto o de los dispositivos conectados.

Para conectar	Para desconectar
<ol style="list-style-type: none"> 1. APÁGUELO todo. 2. En primer lugar, conecte todos los cables a los dispositivos. 3. Conecte los cables de señal a los conectores. 4. Enchufe los cables de alimentación a las tomas de corriente. 5. Encienda el dispositivo. 	<ol style="list-style-type: none"> 1. APÁGUELO todo. 2. En primer lugar, desenchufe los cables de alimentación de las tomas de corriente. 3. Desconecte los cables de señal de los conectores. 4. Desconecte todos los cables de los dispositivos.



PRECAUCIÓN:

Quando sustituya una batería de litio, utilice solamente una batería número de pieza 45C1566 u otra de tipo equivalente recomendada por el fabricante. Si su sistema dispone de un módulo que contiene una batería de litio, reemplácelo sólo con el mismo tipo de módulo, del mismo fabricante. La batería contiene litio y puede explotar si no se utiliza, manipula o desecha correctamente.

No debe:

- Arrojarla al agua o sumergirla en ella
- Exponerla a temperaturas superiores a 100°C (212°F)
- Repararla o desmontarla

Deshágase de la batería según especifiquen las leyes o normas locales.



PRECAUCIÓN:

Quando haya productos láser (como unidades de CD-ROM, unidades de DVD, dispositivos de fibra óptica o transmisores) instalados, tenga en cuenta lo siguiente:

- No quite las cubiertas. Si quita las cubiertas del producto láser, podría quedar expuesto a radiación láser peligrosa. Dentro del dispositivo no existe ninguna pieza que requiera servicio técnico.
- Si usa controles o ajustes o realiza procedimientos que no sean los especificados aquí, podría exponerse a radiaciones peligrosas.



PELIGRO

Algunos productos láser tienen incorporado un diodo láser de clase 3A o clase 3B. Tenga en cuenta lo siguiente:

Cuando se abre, queda expuesto a radiación láser. No mire directamente al rayo láser, ni siquiera con instrumentos ópticos, y evite exponerse directamente al rayo láser.

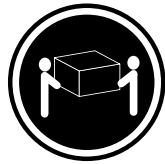

≥18 kg



≥32 kg

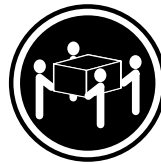

≥55 kg

PRECAUCIÓN:

Adopte procedimientos seguros al levantar el equipo.



PRECAUCIÓN:

El botón de control de alimentación del dispositivo y el interruptor de alimentación de la fuente de alimentación no desconectan la corriente eléctrica suministrada al dispositivo. Además, el dispositivo podría tener más de un cable de alimentación. Para suprimir toda la corriente eléctrica del dispositivo, asegúrese de que todos los cables de alimentación estén desconectados de la toma de corriente.

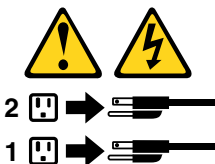

Chapter 3. General information

This chapter provides general information that applies to all machine types supported by this publication.

Specifications

This section lists the physical specifications for your computer.

Dimensions

Width: 210 mm (8.3 inches)

Height: 485 mm (19.1 inches) (floor to top of handle)

Depth: 602 mm (23.7 inches)

Weight

Maximum configuration as shipped: 27.5 kg (60.5 lbs)

Environment

- Air temperature:

Operating: 10°C to 35°C (50°F to 95°F)

Storage: -40°C to 60°C (-40°F to 140°F) in original shipping package

Storage: -10°C to 60°C (14°F to 140°F) without package

Note: The allowable upper temperature limit decreases by 1°C (1.8°F) for every 300 m (1000 ft) above sea level.

- Humidity:

Operating: 10% to 80% (non-condensing) (10% per hour)

Storage: 10% to 90% (non-condensing) (10% per hour)

- Altitude:

Supported altitude: (unpressurized): -50 to 10 000ft (-15.2 to 3 048 m)

Electrical input

- Input voltage:

- Low range:

Minimum: 100 V ac

Maximum: 127 V ac

Input frequency range: 50 to 60 Hz

- High range:

Minimum: 200 V ac

Maximum: 240 V ac

Input frequency range: 50 to 60 Hz

Software overview

The computer comes with a preinstalled operating system and several software programs provided by Lenovo.

Accessing Lenovo programs on the Windows 7 operating system

You can access Lenovo programs on the Windows 7 operating system through Windows Search or from Control Panel. The icon name displayed in the search result or Control Panel might be different from the program name. You can find the program by its program name or icon name as shown in the *Lenovo programs available on the Windows 7 operating system* table.

Note: If you do not find the program you need, open the Lenovo ThinkVantage® Tools program to find the dimmed icon for the program. Then double-click the icon to install the program.

To access Lenovo programs through Windows Search, do the following:

1. Click the **Start** button and then type the program name or the icon name into the search box.
2. Locate the program by the program name or the icon name and then click the program to launch it.

To access Lenovo programs from Control Panel, do the following:

Note: Some Lenovo programs might not be displayed in Control Panel. To find these programs, use Windows Search.

1. Click **Start → Control Panel**. Change the view of Control Panel from Category to Large icons or Small icons.
2. Locate the program by the icon name and then click the program to launch it.

The following table lists the programs available on the Windows 7 operating system.



Note: Depending on your computer model, some of the Lenovo programs might not be available.

Table 1. *Lenovo programs available on the Windows 7 operating system*

Program name	Icon name
Lenovo Reach	Lenovo Reach
Lenovo SHAREit	Lenovo SHAREit
Lenovo Solution Center	Lenovo - System Health and Diagnostics
Lenovo ThinkVantage Tools	Lenovo Thinkvantage Tools
Recovery Media	Lenovo - Factory Recovery Disks or Create Recovery Media
Rescue and Recovery®	Lenovo - Enhanced Backup and Restore

Accessing Lenovo programs on the Windows 8 or Windows 8.1 operating system

If your computer is preinstalled with the Windows 8 or Windows 8.1 operating system, you can access Lenovo programs by doing one of the following:

- On the Windows 8 operating system, press the Windows key  to go to the Start screen. Click a Lenovo program to launch it. If you cannot find the program you need, move the pointer to the bottom-right corner of the screen to display the charms. Then click the **Search** charm to search for the desired program.
- On the Windows 8.1 operating system, press the Windows key  to go to the Start screen. Click a Lenovo program to launch it. If you cannot find the program you need, click the arrow icon  in the bottom-left corner of the screen to go to the Apps screen. Find the desired program in the apps list or search for it in the search box in the top-right corner of the screen.

Depending on your computer model, your computer supports some of the following Lenovo programs:

- Lenovo Cloud Storage
- Lenovo Companion
- Lenovo Reach
- Lenovo SHAREit
- Lenovo Solution Center
- Lenovo Support
- Lenovo Tools
- Password Manager
- System Update

Lenovo Support Web site

Technical support information is available on the Lenovo Support Web site at:
<http://www.lenovo.com/support>

This Web site is updated with the latest support information such as the following:

- Drivers and software
- Diagnostic solutions
- Product and service warranty
- Product and parts details
- User guides and manuals
- Knowledge base and frequently asked questions

Chapter 4. General Checkout

Attention

The drives in the computer you are servicing might have been rearranged or the drive startup sequence might have been changed. Be extremely careful during write operations such as copying, saving, or formatting. Data or programs can be overwritten if you select an incorrect drive.

General error messages appear if a problem or conflict is found by an application program, the operating system, or both. For an explanation of these messages, refer to the information supplied with that software package.

Before replacing a FRU, ensure that the latest level of BIOS is installed on the system. A down-level BIOS might cause false errors and unnecessary replacement of the system board. For more information on how to determine and obtain the latest level BIOS, see “BIOS levels” on page 127.

Use the following procedure to help determine the cause of a problem:

1. Turn off the computer and all external devices.
2. Check all cables and power cords.
3. Set all display controls to the middle position.
4. Turn on all external devices.
5. Turn on the computer.
 - Look for displayed error codes
 - Listen for beep codes
 - Look for readable instructions or a main menu on the display.If you *did not* receive the correct response, proceed to step 6 on page 33.
If you *do* receive the correct response, proceed to step 7 on page 33.
6. Look at the following conditions and follow the instructions:
 - If you hear beep codes during POST, go to “Beep symptoms” on page 67.
 - If the computer displays a POST error, go to “POST error codes” on page 68.
 - If the computer hangs and no error is displayed, continue at step 7 on page 33.
7. Run the Diagnostic programs. See “Diagnostics” on page 52.
 - If the test stops and you cannot continue, replace the last device tested.

Problem determination tips

Due to the variety of hardware and software combinations that can be encountered, use the following information to assist you in problem determination. If possible, have this information available when requesting assistance from Service Support and Engineering functions.

- Machine type and model
- Processor or hard disk drive upgrades
- Failure symptom
 - Do diagnostics indicate a failure?
 - What, when, where, single, or multiple systems?
 - Is the failure repeatable?
 - Has this configuration ever worked?

- If it has been working, what changes were made prior to it failing?
- Is this the original reported failure?
- Diagnostics version
 - Type and version level
- Hardware configuration
 - Print (print screen) configuration currently in use
 - BIOS level
- Operating system software
 - Type and version level

Notes: To eliminate confusion, identical systems are considered identical only if they:

1. Are the exact machine type and models
2. Have the same BIOS level
3. Have the same adapters/attachments in the same locations
4. Have the same address jumpers/terminators/cabling
5. Have the same software versions and levels
6. Have the same diagnostic diskettes (version)
7. Have the same configuration options set in the system
8. Have the same setup for operating-system-controlled files

Comparing the configuration and software set-up between “working and non-working” systems will often lead to problem resolution.

Chapter 5. Troubleshooting and diagnostics

This chapter describes some basic troubleshooting and diagnostic programs. If your computer problem is not described here, see “Lenovo Support Web site” on page 31 for additional troubleshooting resources.

Basic troubleshooting

The following table provides information to help you troubleshoot your computer problems.

Note: If you cannot correct the problem, have the computer serviced. For a list of service and support telephone numbers, refer to the *ThinkStation Safety, Warranty, and Setup Guide* that comes with your computer or go to the Lenovo Support Web site at <http://www.lenovo.com/support/phone>.

Symptom	Action
The computer does not start when you press the power button.	Verify that: <ul style="list-style-type: none">• The power cord is correctly connected to the rear of the computer and to a working electrical outlet.• If your computer has a secondary power button on the rear of the computer, make sure that it is switched on.• The power indicator on the front of the computer is on.• The computer voltage matches the voltage available at the electrical outlet for your country or region.
The monitor screen is blank.	Verify that: <ul style="list-style-type: none">• The monitor signal cable is correctly connected to the monitor and to the appropriate monitor connector on the computer.• The monitor power cord is correctly connected to the monitor and to a working electrical outlet.• The monitor is turned on and the brightness and contrast controls are set correctly.• The computer voltage matches the voltage available at the electrical outlet for your country or region.• If your computer has two monitor connectors, be sure to use the connector on the graphics card.
The keyboard does not work.	Verify that: <ul style="list-style-type: none">• The computer is turned on.• The keyboard is securely connected to a USB connector on the computer.• No keys are stuck.
The mouse does not work.	Verify that: <ul style="list-style-type: none">• The computer is turned on.• The mouse is securely connected to a USB connector on the computer.• The mouse is clean. Refer to “Optical mouse” on page 43 for further information.

Symptom	Action
The operating system does not start.	Verify that: <ul style="list-style-type: none"> The startup sequence includes the device where the operating system resides. Usually, the operating system is on the hard disk drive. For more information, see "Selecting a startup device" on page 57.
The computer beeps multiple times before the operating system starts.	Verify that no keys are stuck.

Accessing Control Panel on the Windows 8 or Windows 8.1 operating system

On the Windows operating system, you can view and change computer settings through Control Panel. To access Control Panel on the Windows 8 or Windows 8.1 operating system, do one of the following:

- From the desktop
 - Move the pointer to the top-right or bottom-right corner of the screen to display the charms.
 - Click **Settings**.
 - Click **Control Panel**.
- From the Start screen
 - For Windows 8:
 - Move the pointer to the top-right or bottom-right corner of the screen to display the charms.
 - Click **Search**.
 - On the Apps screen, scroll to the right side, and click **Control Panel** in the **Windows System** section.
 - For Windows 8.1:
 - Click the arrow icon  in the bottom-left corner of the screen to go to the Apps screen.
 - Scroll to the right side, and click **Control Panel** in the **Windows System** section.

Troubleshooting procedure

Use the following procedure as a starting point for diagnosing problems you are experiencing with your computer:

- Verify that the cables for all attached devices are connected correctly and securely.
- Verify that all attached devices that require ac power are connected to properly grounded, functioning electrical outlets.
- Verify that all attached devices are enabled in the BIOS settings of your computer. For more information about accessing and changing the BIOS settings, refer to your Chapter 6 "Using the Setup Utility program" on page 55.
- Go to the "Troubleshooting" on page 37 and follow the instructions for the type of problem you are experiencing. If the Troubleshooting information does not help you resolve a problem, continue with the next step.
- Try using a previously captured configuration to see if a recent change to hardware or software settings has caused a problem. Before restoring a previous configuration, capture your current configuration in case the older configuration settings do not solve the problem or have adverse affects. To restore a captured configuration, do the following:
 - For Windows 7: Click **Start** → **Control Panel** → **System and Security** → **System** → **System Protection** → **System Restore**.

- For Windows 8 or Windows 8.1: Open Control Panel, and then click **System and Security → System → System Protection → System Restore**.

If this does not correct the problem, continue with the next step.

6. Run the diagnostic program. See “Lenovo Solution Center” on page 53 for more information.
 - If the diagnostic program detects a hardware failure, contact the Lenovo Customer Support Center. See “Lenovo Support Web site” on page 31 for more information.
 - If you are unable to run the diagnostic program, contact the Lenovo Customer Support Center. See “Lenovo Support Web site” on page 31 for more information.
 - If the diagnostic program does not detect a hardware failure, continue with the next step.
7. Use an antivirus program to see if your computer has been infected by a virus. If the program detects a virus, remove the virus.
8. If none of these actions solve the problem, seek technical assistance. See “Lenovo Support Web site” on page 31 for more information.

Troubleshooting

Use the troubleshooting information to find solutions to problems that have definite symptoms.

If the symptom your computer is experiencing occurred immediately after you installed a new hardware option or new software, do the following before referring to the troubleshooting information:

1. Remove the new hardware option or software. If you must remove the computer cover to remove a hardware option, make sure you review and follow the electrical safety information provided with your computer. For your safety, do not operate the computer with the cover removed.
2. Run the diagnostic programs to ensure your computer is operating correctly.
3. Reinstall the new hardware option or software following the manufacturer's instructions.

Select the problem your computer is experiencing from the following list:

- “Audio problems” on page 37
- “CD problems” on page 39
- “DVD problems” on page 40
- “Intermittent problems” on page 41
- “Hard disk drive problems” on page 41
- “Keyboard, mouse, or pointing device problems” on page 42
- “Monitor problems” on page 44
- “Networking problems” on page 46
- “Option problems” on page 48
- “Performance and lockup problems” on page 48
- “Printer problems” on page 50
- “Serial port problems” on page 51
- “Software problems” on page 51
- “USB problems” on page 52

Audio problems

Select your symptom from the following list:

- “No audio in Windows” on page 38

- “An audio disc or AutoPlay-enabled disc does not automatically play when it is inserted into a drive” on page 38
- “Sound comes from one external speaker only” on page 38
- “No audio in DOS applications or games” on page 38

No audio in Windows

Symptom: No audio in Windows

Actions:

- If you are using powered external speakers that have an On/Off control, verify that the On/Off control is set to the **On** position and the speaker power cable is connected to a properly grounded, functional ac electrical outlet.
- If your external speakers have a volume control, verify that the volume control is not set too low.
- Double-click the speaker icon in the Windows notification area. A master volume-control window opens. Verify that the **Mute** settings are not checked and none of the volume settings is set too low.
- Verify that your external speakers (and headphones, if used) are connected to the correct audio connector on the computer. Most speaker cables are color-coded to match the connector.

Note: When external-speaker or headphone cables are attached to the audio connector, the internal speaker, if present, is disabled. In most cases, if an audio adapter is installed in one of the expansion slots, the audio function built into the system board is disabled; use the audio jacks on the adapter.

- Make sure that the program you are running is designed for use in the Microsoft Windows operating system. If the program is designed to run in DOS, the program does not use the Windows sound feature and must be configured to use SoundBlaster Pro or SoundBlaster emulation.
- Verify that the audio device drivers are correctly installed. See Microsoft Windows help system for more information.

If these actions do not correct the problem, run the diagnostic programs (see “Lenovo Solution Center” on page 53 for instructions). If you need technical assistance, see “Lenovo Support Web site” on page 31.

An audio disc or AutoPlay-enabled disc does not automatically play when it is inserted into a drive

Symptom: An audio disc or AutoPlay-enabled disc does not automatically play when it is inserted into a drive

Action: See “CD problems” on page 39.

Sound comes from one external speaker only

Symptom: Sound comes from one external speaker only.

Actions:

- Ensure that the speaker cable is inserted completely into the connector on the computer.
- Make sure the cable that attaches the left speaker to the right speaker is securely connected.
- Double-click the speaker icon in the Windows notification area. A master volume-control window opens. Verify that the Balance settings are set correctly.

If these actions do not correct the problem, you might have a failing speaker. Have the speaker serviced. If you need technical assistance, see “Lenovo Support Web site” on page 31.

No audio in DOS applications or games

Symptom: No audio in DOS applications or games

Actions:

- Make sure the DOS application or game is configured to use SoundBlaster Pro or SoundBlaster emulation. Refer to the documentation that comes with the application or game for instructions on setting sound-card settings.
- If these actions do not correct the problem, run the diagnostic programs (see “Lenovo Solution Center” on page 53 for instructions). If you need technical assistance, see “Lenovo Support Web site” on page 31.

CD problems

Select your symptom from the following list:

- “An audio disc or AutoPlay-enabled disc does not automatically play when it is inserted into a CD drive” on page 39
- “A CD or DVD does not work” on page 39
- “Unable to use a startable (bootable) recovery medium, such as the Product Recovery CD, to start your computer” on page 39

An audio disc or AutoPlay-enabled disc does not automatically play when it is inserted into a CD drive

Symptom: An audio disc or AutoPlay-enabled disc does not automatically play when it is inserted into a CD drive.

Actions:

- If you have multiple CD or DVD drives installed (or a combination of CD and DVD drives), try inserting the disc into the other drive. In some cases, only one of the drives is connected to the audio subsystem.
- If you are using the Windows 7 operating system, follow the action for “A CD or DVD does not work” on page 39.

If this does not correct the problem, follow the action for “A CD or DVD does not work” on page 39.

A CD or DVD does not work

Symptom: A CD or DVD does not work.

Actions:

- Verify that the disc is inserted correctly, with its label up.
- Make sure that the disc you are using is clean. To remove dust or fingerprints, wipe the disc clean with a soft cloth from the center to the outside. Wiping a disc in a circular motion might cause loss of data.
- Verify that the disc you are using is not scratched or damaged. Try inserting another disc that you know is good. If you cannot read from a known-good disc, you might have a problem with your CD or DVD drive or the cabling to your CD or DVD drive. Make sure that the power cable and signal cable are securely connected to the drive.

Unable to use a startable (bootable) recovery medium, such as the Product Recovery CD, to start your computer

Symptom: Unable to use a startable (bootable) recovery medium, such as the Product Recovery CD, to start your computer.

Action: Make sure that the CD or DVD drive is in the startup sequence before the hard disk drive. Refer to your “Selecting or changing the startup device sequence” on page 58 for information on viewing and changing the startup sequence. Note that on some models the startup sequence is permanently set and cannot be changed.

If these actions do not correct the problem, run the diagnostic programs (see “Lenovo Solution Center” on page 53 for instructions). If you need technical assistance, see “Lenovo Support Web site” on page 31.

DVD problems

Select your symptom from the following list:

- “Black screen instead of DVD video” on page 40
- “DVD movie will not play” on page 40
- “No audio or intermittent audio while playing DVD movie” on page 40
- “Playback is very slow or choppy” on page 40
- “Invalid disc or no disc found message” on page 41

Black screen instead of DVD video

Symptom: Black screen instead of DVD video

Actions:

- Restart the DVD player program.
- Close any open files, turn off the computer, and then restart the computer.
- Try a lower screen resolution or color depth.

If these actions do not correct the problem, run the diagnostic programs (see “Lenovo Solution Center” on page 53 for instructions). If you need technical assistance, see “Lenovo Support Web site” on page 31.

DVD movie will not play

Symptom: DVD movie will not play.

Actions:

- Make sure that the disc surface is clean and not scratched.
- Check the disc or package for regional coding. You might need to purchase a disc with coding for the region where you are using your computer.

If these actions do not correct the problem, run the diagnostic programs (see “Lenovo Solution Center” on page 53 for instructions). If you need technical assistance, see “Lenovo Support Web site” on page 31.

No audio or intermittent audio while playing DVD movie

Symptom: No audio or intermittent audio while playing DVD movie.

Actions:

- Check the volume control settings on your computer and on your speakers.
- Make sure that the disc surface is clean and not scratched.
- Check all cable connections to and from the speakers.
- Use the DVD menu for the video to select a different audio track.

If these actions do not correct the problem, run the diagnostic programs (see “Lenovo Solution Center” on page 53 for instructions). If you need technical assistance, see “Lenovo Support Web site” on page 31.

Playback is very slow or choppy

Symptom: Playback is very slow or choppy.

Actions:

- Disable any background programs, such as AntiVirus or Desktop Themes.
- Ensure that video resolution is set to less than 1152 x 864.

If these actions do not correct the problem, run the diagnostic programs (see “Lenovo Solution Center” on page 53 for instructions). If you need technical assistance, see “Lenovo Support Web site” on page 31.

Invalid disc or no disc found message

Symptom: Invalid disc or no disc found message

Actions:

- Ensure that a DVD disc is in the drive with the shiny side of the disc facing down.
- Ensure that video resolution is set to less than 1152 x 864.
- On computers that have a CD-ROM or CD-RW drive in addition to a DVD-ROM drive, make sure that the DVD disc is in the drive labeled “DVD”.

If these actions do not correct the problem, run the diagnostic programs (see “Lenovo Solution Center” on page 53 for instructions). If you need technical assistance, see “Lenovo Support Web site” on page 31.

Intermittent problems

Symptom: A problem occurs only occasionally and is difficult to repeat.

Actions:

- Verify that all cables and cords are securely connected to the computer and attached devices.
- Verify that when the computer is on, the fan grill is not blocked (there is air flow around the grill), and the fans are working. If airflow is blocked or the fans are not working, the computer might overheat.

If these actions do not correct the problem, run the diagnostic programs (see “Lenovo Solution Center” on page 53 for instructions). If you need technical assistance, see “Lenovo Support Web site” on page 31.

Hard disk drive problems

Select your symptom from the following list:

- “Some or all hard disk drives missing from the Setup Utility program” on page 41
- ““No Operating System Found” message or the system not starting from the correct hard disk drive” on page 42

Some or all hard disk drives missing from the Setup Utility program

Symptom: Some or all hard disk drives missing from the Setup Utility program

Actions:

- Ensure that all hard disk drive signal cables and power cables are connected correctly. Refer to “Installing or replacing a hard disk drive” on page 103.
- Ensure that your computer is configured correctly to support the hard disk drives.
 - If your computer is installed with five SATA hard disk drives, ensure that the SATA hard disk drive enablement module (one to five hard disk drives) is installed.
 - If your computer is installed with SAS hard disk drives, ensure that the SAS hard disk drive enablement module (one to five hard disk drives) or the LSI MegaRAID SAS adapter is installed.

If these actions do not correct the problem, run the diagnostic program Lenovo Solution Center. See “Lenovo Solution Center” on page 53. If you need technical assistance, see “Lenovo Support Web site” on page 31.

"No Operating System Found" message or the system not starting from the correct hard disk drive

Symptom: "No Operating System Found" message or the system not starting from the correct hard disk drive

Actions:

- Ensure that all hard disk drive signal cables and power cables are connected correctly. Refer to “Installing or replacing a hard disk drive” on page 103.
- Ensure that the hard disk drive your computer starts from is listed as the first startup device in the Setup Utility program. Refer to “Selecting a startup device” on page 57.
- If you are using RAID, ensure that you have configured the hard disk drives correctly. Refer to Chapter 7 “Configuring RAID” on page 61.

Note: In rare cases, the hard disk drive with the operating system might get corrupted or damaged. In such cases, you might need to replace the hard disk drive. Refer to “Installing or replacing a hard disk drive” on page 103. Additionally, you might need to recover the data on the hard disk drive, or restore the hard disk drive to the factory default state. Refer to the Using the Rescue and Recovery workspace section in User Guide for more information.

If these actions do not correct the problem, run the diagnostic program Lenovo Solution Center. See “Lenovo Solution Center” on page 53. If you need technical assistance, see “Lenovo Support Web site” on page 31.

Keyboard, mouse, or pointing device problems

Select your symptom from the following list:

- “All or some keys on the keyboard do not work” on page 42
- “The mouse or pointing device does not work” on page 43
- “The pointer on the screen does not move smoothly with the mouse” on page 43
- “The wireless keyboard does not work” on page 44

All or some keys on the keyboard do not work

Symptom: All or some keys on the keyboard do not work.

Actions:

- Verify that the keyboard cable is securely connected to the correct connector on the computer.
- If you are using an Enhanced Performance USB keyboard and one or more of the Rapid Access buttons are the only keys that are not working, these buttons might have been disabled or have not been assigned to a function. Use the help system in the Enhanced Performance Customization Keyboard program to help diagnose problems with the Rapid Access buttons.

To open the Enhanced Performance Customization Keyboard program, do one of the following:

- On the Windows 7 operating system, do the following:
 1. Click **Start → Control Panel**.
 2. Click **Hardware and Sound**.
 3. Click **Devices and Printers**.
 4. Double-click **USB Enhanced Performance Keyboard**. The USB Enhanced Performance Keyboard Customization program starts.
- On the Windows 8 or Windows 8.1 operating system, do the following:

1. Open Control Panel.
2. Click **Hardware and Sound**.
3. Click **Devices and Printers**.
4. Double-click **USB Enhanced Performance Keyboard**. The USB Enhanced Performance Keyboard Customization program starts.

If these actions do not correct the problem, have the computer and keyboard serviced. See “Lenovo Support Web site” on page 31 for details.

The mouse or pointing device does not work

Symptom: The mouse or pointing device does not work.

Actions:

- Verify that the mouse or pointing-device cable is securely attached to the correct connector on the computer. Depending on the type of mouse you have, the mouse cable will connect to either the mouse, serial, or USB connector. Some keyboards have integrated USB connectors that can be used for a USB mouse or pointing device.
- Verify that the device drivers for the mouse or pointing device are installed correctly.
- If you are using a USB keyboard or mouse, verify that the USB connectors are enabled in the BIOS settings. See “Enabling or disabling a device” on page 57.

If these actions do not correct the problem, run the diagnostic programs (see “Lenovo Solution Center” on page 53 for instructions). If you need technical assistance, see “Lenovo Support Web site” on page 31.

Optical mouse

This section provides instructions on how to clean an optical mouse.

An optical mouse uses a light-emitting diode (LED) and an optical sensor to navigate the pointer. If the pointer on the screen does not move smoothly with the optical mouse, you might need to clean the mouse.

To clean an optical mouse, do the following:

1. Turn off your computer.
2. Disconnect the mouse cable from the computer.
3. Turn the mouse upside down to check the lens.
 - a. If there is a smudge on the lens, gently clean the area with a plain cotton-tipped swab.
 - b. If there is debris in the lens, gently blow the debris away from the area.
4. Check the surface on which you are using the mouse. If you have a very intricate picture or pattern beneath the mouse, it may be difficult for the digital signal processor (DSP) to determine changes in the mouse position.
5. Reconnect the mouse cable to the computer.
6. Turn your computer back on.

The pointer on the screen does not move smoothly with the mouse

Symptom: The pointer on the screen does not move smoothly with the mouse.

Action: Erratic movement of the mouse pointer is generally caused by a buildup of dirt, oils, and other contaminants on the ball inside the mouse. Clean the mouse. See “Optical mouse” on page 43 for instructions.

The fingerprint reader does not work

Symptom: The fingerprint reader does not work.

Action: The following could cause the fingerprint reader not to operate properly:

- Not enrolling your fingerprint correctly.
- Scratching the surface of the reader with a hard, pointed object.
- Scraping the surface of the reader with your nail or anything hard.
- Using or touching the reader with a dirty finger.
- The surface of your finger is very different from when you enrolled your fingerprint.

The wireless keyboard does not work

Symptom: The wireless keyboard does not work.

Action: If the Transceiver Communications LED is on and the wireless Keyboard does not work, restart your computer. If restarting your computer does not solve the problem, verify that the following conditions are met:

- The batteries are properly installed.
- The batteries still retain their current.
- The wireless Keyboard is located less than ten meters away from the transceiver.
- The transceiver is fully installed.

Action: If the Transceiver Communications LED is not on, reconnect the transceiver and the keyboard.

Monitor problems

Note: Many monitors have status-indicator lights and built-in controls for adjusting brightness, contrast, width, height, and other picture adjustments. However, the controls vary from monitor type to monitor type. For information about the status lights and using the controls, refer to the documentation that comes with your monitor.

Select your symptom from the following list:

- “Wrong characters appear on the screen” on page 44
- “The monitor works when you turn on the computer, but goes blank after some period of computer inactivity” on page 44
- “The monitor works when you turn on the computer, but goes blank when you start some application programs” on page 45
- “The image appears to be flickering” on page 45
- “The image is discolored” on page 45

Wrong characters appear on the screen

Symptom: Wrong characters appear on the screen.

Action: Have the computer serviced. For details, see “Lenovo Support Web site” on page 31.

The monitor works when you turn on the computer, but goes blank after some period of computer inactivity

Symptom: The monitor works when you turn on the computer, but goes blank after some period of computer inactivity.

Action: The computer is probably set for energy savings with the power-management feature. If the power-management feature is enabled, disabling it or changing the settings might solve the problem.

If these actions do not correct the problem, run the diagnostic programs (see “Lenovo Solution Center” on page 53 for instructions). If you need technical assistance, see “Lenovo Support Web site” on page 31.

The monitor works when you turn on the computer, but goes blank when you start some application programs

Symptom: The monitor works when you turn on the computer, but goes blank when you start some application programs.

Actions:

- Make sure the monitor signal cable is securely connected to the monitor and the monitor connector on the computer. A loose cable can cause intermittent problems.
- Verify that the necessary device drivers for the application programs are installed. Refer to the documentation for the affected application program to see if device drivers are required.

If these actions do not correct the problem, run the diagnostic programs (see “Lenovo Solution Center” on page 53 for instructions). If you need technical assistance, see “Lenovo Support Web site” on page 31.

The image appears to be flickering

Symptom: The image appears to be flickering.

Actions:

- The monitor might be operating in a low-refresh rate display mode. Set the monitor to the highest, noninterlaced refresh rate supported by your monitor and the video controller in your computer.
Attention: Using a resolution or refresh rate that is not supported by your monitor might damage it. Check the documentation that comes with your monitor to verify the supported refresh rates.
- The monitor might be affected by interference from nearby equipment. Magnetic fields around other devices, such as transformers, appliances, fluorescent lights, and other monitors might be causing the problem. Move fluorescent desk lighting or any equipment that produces magnetic fields farther away from the monitor. If this does not correct the problem, do the following:
 1. Turn off the monitor. (Moving a color monitor while it is turned on might cause screen discoloration.)
 2. Adjust the placement of the monitor and other devices so that they are at least 305 mm (12 inches) apart.
 3. Turn on the monitor.
- You can reset the refresh rate through your operating system Control Panel:
On the Windows 7 operating system, click **Start → Control Panel → Hardware and Sound → Adjust screen resolution → Advanced Settings**. Then click the **Monitor** tab and select a new refresh rate.
On the Windows 8 or Windows 8.1 operating system, open Control Panel and click **Hardware and Sound → Adjust screen resolution → Advanced Settings**. Then click the **Monitor** tab and select a new refresh rate.
- See your operating system documentation or help for further information on monitor settings.

If these actions do not correct the problem, your monitor might need service. See “Lenovo Support Web site” on page 31 for details.

The image is discolored

Symptom: The image is discolored.

Action: The monitor might be affected by interference from nearby equipment. Magnetic fields around other devices, such as transformers, appliances, fluorescent lights, and other monitors might be causing the problem. Move fluorescent desk lighting or any equipment that produces magnetic fields further away from the monitor. If this does not correct the problem, do the following:

1. Turn off the monitor. (Moving a color monitor while it is turned on might cause screen discoloration.)
2. Adjust the placement of the monitor and other devices so that they are at least 305 mm (12 inches) apart.
3. Turn on the monitor.

If these actions do not correct the problem, your monitor might need service. See “Lenovo Support Web site” on page 31 for details.

Networking problems

The following are the most common networking problems. Select your networking problem from the following list:

- “Ethernet problems” on page 46

Ethernet problems

For Ethernet problems, select your symptom from the following list:

- “Your computer cannot connect to the network” on page 46
- “The adapter stops working for no apparent reason” on page 47
- “If your computer is a Gigabit Ethernet model and you use a speed of 1000 Mbps, the connection fails or errors occur” on page 47
- “If your computer is a Gigabit Ethernet model, it cannot connect to the network at 1000 Mbps. Instead, it connects at 100 Mbps” on page 47

Your computer cannot connect to the network

Symptom: Your computer cannot connect to the network.

Actions: Ensure that:

- The cable is installed properly.

The network cable must be securely connected to both the Ethernet connector of your computer and the RJ45 connector of the hub. The maximum allowable distance from the computer to hub is 100 meters. If the cable is connected and the distance is within acceptable limits but the problem persists, try a different cable.

- The cable is installed properly.
- You are using the correct device driver.

On the Windows 7 operating system, do the following:

1. Click **Start** → **Control Panel**.
2. Click **Hardware and Sound**.
3. Click **Device Manager**. If you are prompted for an administrator password or confirmation, type the password or provide confirmation.
4. If an exclamation mark is displayed next to an adapter name under **Network adapters**, you might not be using the correct driver or the driver is not enabled. To update the driver, right-click the highlighted adapter.
5. Click **Update Driver Software**, and then follow the instructions on the screen.

On the Windows 8 or Windows 8.1 operating system, open Control Panel and click **Hardware and Sound** → **Adjust screen resolution** → **Advanced Settings**. Then click the **Monitor** tab and select a new refresh rate. On the Windows 8 or Windows 8.1 operating system, do the following:

1. Open Control Panel.
 2. Click **Hardware and Sound**.
 3. Click **Device Manager**. If you are prompted for an administrator password or confirmation, type the password or provide confirmation.
 4. If an exclamation mark is displayed next to an adapter name under **Network adapters**, you might not be using the correct driver or the driver is not enabled. To update the driver, right-click the highlighted adapter.
 5. Click **Update Driver Software**, and then follow the instructions on the screen.
- The switch port and the adapter have the same duplex setting.
If you configured the adapter for full duplex, ensure that the switch port is also configured for full duplex. Setting the wrong duplex mode can degrade performance, cause data loss, or result in lost connections.
 - You have installed all networking software that is necessary for your network environment.
Check with your LAN administrator for the necessary networking software.

The adapter stops working for no apparent reason

Symptom: The adapter stops working for no apparent reason.

Action: The network driver files may be corrupt or missing. Update the driver by referring to the “Solution” description for the procedure to make sure that the correct device driver is installed.

The Wake on LAN feature is not working

Symptom: The Wake on LAN (WOL) feature is not working.

Actions:

- Make sure that WOL is enabled in the BIOS Setup Utility program.
- If it is, check with your LAN administrator for the necessary settings.

If your computer is a Gigabit Ethernet model and you use a speed of 1000 Mbps, the connection fails or errors occur

Symptom: If your computer is a Gigabit Ethernet model and you use a speed of 1000 Mbps, the connection fails or errors occur.

Actions:

- Use Category 5 wiring and make sure that the network cable is securely connected.
- Connect to a 1000 BASE-T hub/switch (not 1000 BASE-X).

If your computer is a Gigabit Ethernet model, it cannot connect to the network at 1000 Mbps. Instead, it connects at 100 Mbps

Symptom: If your computer is a Gigabit Ethernet model, it cannot connect to the network at 1000 Mbps. Instead, it connects at 100 Mbps.

Actions:

- Try another cable.
- Make sure that the link partner is set to auto-negotiate.
- Make sure that the switch is 802.3ab-compliant (gigabit over copper).

Option problems

Use this information to diagnose problems with Lenovo hardware options that do not have their own troubleshooting information.

Select your symptom from the following list:

- “An option that was just installed does not work” on page 48
- “An option that previously worked does not work now” on page 48

An option that was just installed does not work

Symptom: An option that was just installed does not work.

Action: Verify that:

- The option is designed for your computer.
- You followed the installation instructions supplied with the option and the installation instructions provided with your computer, and all option files (such as device drivers, if required) are installed correctly.
- You have not loosened other installed options or cables.
- If the option is an adapter, you have provided enough hardware resources for the adapter to function correctly. See the documentation supplied with the adapter (as well as the documentation for any other installed adapters) to determine the resources required for each adapter.

If these actions do not correct the problem, run the diagnostic programs (see “Lenovo Solution Center” on page 53 for instructions). If you need technical assistance, see “Lenovo Support Web site” on page 31.

An option that previously worked does not work now

Symptom: An option that previously worked does not work now.

Actions:

- Verify that all option hardware and cable connections are secure.
- If the option comes with its own test instructions, use those instructions to test the option.
- If the failing option is a SCSI option, verify that:
 - The cables for all external SCSI options are connected correctly.
 - The last option in each SCSI chain, or the end of the SCSI cable, is terminated correctly.
 - All external SCSI options are turned on. External SCSI options must be turned on before the computer is turned on. For more information, see your SCSI documentation.
- Verify that the option and any required device drivers are installed correctly.

If these actions do not correct the problem, run the diagnostic programs (see “Lenovo Solution Center” on page 53 for instructions). If you need technical assistance, see “Lenovo Support Web site” on page 31.

Performance and lockup problems

Poor performance and lockup problems can be a result of any of the following:

- “Insufficient free hard disk drive space” on page 49
- “Excessive number of fragmented files” on page 49
- “Insufficient memory” on page 50

Make a selection from the above list to find out more about the corrective actions you can take.

Insufficient free hard disk drive space

Symptom: Insufficient free hard disk drive space

The Windows operating system will slow down and might produce errors if the hard disk drive gets too full.

To check the amount of free space on the Windows 7 operating system, do the following:

1. Click **Start → Computer**.
2. Right-click your C drive entry and then click **Properties**. The amount of free disk space is displayed.

To check the amount of free space on the Windows 8 operating system, do the following:

1. Open File Explorer and click **Computer**.
2. Right-click your C drive entry and then click **Properties**. The amount of free disk space is displayed.

To check the amount of free space on the Windows 8.1 operating system, do the following:

1. Open File Explorer.
2. Right-click your C drive entry and then click **Properties**. The amount of free disk space is displayed.

To free up disk space, do any of the following:

- Method 1
 1. On the Windows 7 operating system, click **Start → Computer**. On the Windows 8 operating system, open File Explorer and click **Computer**. On the Windows 8.1 operating system, open File Explorer.
 2. Right-click your C drive entry and then click **Properties**.
 3. Click **Disk Cleanup**.
 4. A list of unnecessary file categories is displayed. Select each file category you want to delete, and then click **OK**.
- Method 2
 1. Open Control Panel.
 2. Click **Programs**.
 3. Click **Turn Windows features on or off**.
 4. A list of optional Windows components is displayed. Follow the instructions on the screen.
- Method 3
 1. On the Windows 7 operating system, click **Start → Computer**. On the Windows 8 operating system, open File Explorer and click **Computer**. On the Windows 8.1 operating system, open File Explorer.
 2. Right-click your C drive entry and then click **Properties**.
 3. Click **Disk Cleanup**.
 4. Click **Clean up system files**.
 5. Click the **More Options** tab.
 6. In the **Programs and Features** area, click the **Clean up** button.
 7. A list of installed programs is displayed. Select the program that you want to remove. Click **Uninstall/Change** or **Uninstall**.
- Clean out your Inbox, Sent Items, and Deleted Items folders from your e-mail application. The folder names and procedures vary depending on your e-mail application. If you need assistance, see the help system for your e-mail application.

Excessive number of fragmented files

Symptom: Excessive number of fragmented files

Action: Run the Windows Disk Defragmenter program.

Note: Depending on the size of the hard disk drive and amount of data currently stored on the hard disk drive, the disk-defragmentation process might take up to several hours to complete.

On the Windows 7 operating system, do the following:

1. Close any programs that are currently running and close any open windows.
2. Click **Start → Computer**.
3. Right-click your C drive entry and then click **Properties**.
4. Click the **Tools** tab.
5. Click **Defragment Now**, then click **Continue**.
6. Click **Defragment Now** again to start a disk-defragmentation process.

On the Windows 8 or Windows 8.1 operating system, do the following:

1. Close any programs that are currently running and close any open windows.
2. On Windows 8, open File Explorer and click **Computer**. On Windows 8.1, open File Explorer.
3. Right-click your C drive entry and then click **Properties**.
4. Click the **Tools** tab and then click **Optimize**.
5. Click **Optimize** in the Optimize Drives window that is displayed to start a disk-defragmentation process.

Insufficient memory

Symptom: Insufficient memory

In general, the more memory that is installed, the better the Windows operating system runs.

Action: Install additional memory. For information about purchasing memory, see “Lenovo Support Web site” on page 31. For step-by-step instructions on installing memory, see “Installing or replacing a memory module” on page 89.

If these actions do not correct the problem, run the diagnostic programs (see “Lenovo Solution Center” on page 53 for instructions). If you need technical assistance, see “Lenovo Support Web site” on page 31.

Printer problems

Symptom: The printer does not work.

Actions: Verify that:

1. The printer is turned on and is online.
2. Paper is loaded correctly.
3. The printer signal cable is securely connected to the correct parallel, serial, or USB connector on the computer.

Note: Non-IEEE-approved printer signal cables might cause unpredictable problems.

1. Any device drivers and other software that came with the printer are correctly installed.
2. You have assigned the printer port correctly in your operating system, application program, or BIOS settings. For more information about BIOS settings, see Chapter 6 “Using the Setup Utility program” on page 55.

If the problem persists, run the tests described in the documentation that comes with your printer. If you cannot correct the problem, have the computer serviced. See “Lenovo Support Web site” on page 31.

Serial port problems

Use this information to troubleshoot the serial port and devices attached to the serial port.

Symptom: Serial port cannot be accessed.

Actions:

- Make sure the serial cable is securely connected to the serial port on the computer and to the serial device. If the serial device has its own power cord, make sure it is attached to a properly grounded electrical outlet.
- If the serial device has its own On/Off switch, make sure it is in the On position.
- If the serial device has an Online switch, make sure it is in the Online position.
- If the serial device is a printer, make sure paper is loaded correctly.
- Verify that any software supplied with the serial device is correctly installed. Refer to the documentation for the serial-device option.
- Make sure that the serial-port adapter, if you added one, is properly installed and firmly seated.

If these actions do not correct the problem, run the diagnostic programs (see “Lenovo Solution Center” on page 53 for instructions). If you need technical assistance, see “Lenovo Support Web site” on page 31.

Software problems

Select your symptom from the following list:

- “When using a sort feature, dates do not sort in the correct order” on page 51
- “Software does not work as expected” on page 51

When using a sort feature, dates do not sort in the correct order

Symptom: When using a sort feature, dates do not sort in the correct order.

Action: Some software developed before the year 2000 used only the last two digits of a year to sort dates, always assuming the first two digits were 19. Consequently, these programs sort dates out of order. Check with your software manufacturer to see if any updates are available. Many software manufacturers make updates available from the World Wide Web.

Software does not work as expected

Symptom: Software does not work as expected.

Actions:

- Most software programs have built-in help systems that provide instructions for most tasks. If you are having difficulty performing a specific task within a software program, refer to the help system for that program. Help systems are typically accessible from a menu or button in the program, and frequently from the F1 key.
- If you are having difficulty with the Windows operating system or one of its components, refer to the Windows help system. It is accessible from the Windows **Start** menu.
- To determine if problems are caused by newly installed software, verify that:
 - Your computer has the minimum memory requirements needed to use the software. See the information supplied with the software to verify memory requirements. (If you just installed an adapter or memory, you might have a memory-address conflict.)
 - The software is designed to operate on your computer.

- Other software works on your computer.
- The software you are using works correctly on another computer.
- If you received any error messages while using the software program, see the printed documentation supplied with the software or the help system for that software for a description of the messages and solutions to the problem.
- Check with your software manufacturer to see if any updates are available. Many software manufacturers make updates available from the World Wide Web.
- If the software program used to work correctly, but does not work correctly now, do the following:
 - On the Windows 7 operating system, click **Start → Control Panel → System and Security → System → System Protection → System Restore**. Then, follow the instructions on the screen.
 - On the Windows 8 or Windows 8.1 operating system, open Control Panel and click **System and Security → System → System Protection → System Restore**. Then, follow the instructions on the screen.
- If you are unable to resolve the problem through other methods, uninstall the software program and reinstall it.

If these actions do not correct the problem, you might need technical assistance. Contact your software manufacturer or see “Lenovo Support Web site” on page 31 for details.

USB problems

Symptom: The USB connectors cannot be accessed.

Actions:

- Make sure the USB cable is securely connected to the USB connector and to the USB device. If the USB device has its own power cord, make sure it is attached to a properly grounded electrical outlet.
- If the USB device has its own On/Off switch, make sure it is in the On position.
- If the USB device has an Online switch, make sure it is in the Online position.
- If the USB device is a printer, make sure paper is loaded correctly.
- Make sure any device drivers or other software supplied with the USB device is correctly installed. Refer to the documentation for the USB device.
- Reset the device by detaching and reattaching the USB connector.

If these actions do not correct the problem, run the diagnostic programs to test the USB connector (see “Lenovo Solution Center” on page 53 for instructions). If the USB device came with its own diagnostics, run those diagnostics against the USB device. If you need technical assistance, see “Lenovo Support Web site” on page 31.

Diagnostics

The diagnostic program is used to test hardware components of your computer. The diagnostic program can also report operating-system-controlled settings that interfere with the correct operation of your computer. You can use the preinstalled diagnostic program to diagnose computer problems, if your computer is running the Windows operating system.

Notes:

1. Your computer is preinstalled with the Lenovo Solution Center program for diagnostic purposes. For more information about the Lenovo Solution Center program, see “Lenovo Solution Center” on page 53.

2. If you are unable to isolate and repair the problem yourself after running the diagnostic program, save and print the log files created by the diagnostic program. You will need the log files when you speak to a Lenovo technical support representative.

Lenovo Solution Center

The Lenovo Solution Center program enables you to troubleshoot and resolve computer problems. It combines diagnostic tests, system information collection, security status, and support information, along with hints and tips for maximum system performance.

Notes:

- The Lenovo Solution Center program can be downloaded from <http://www.lenovo.com/diags>.
- If you are using a Windows operating system other than Windows 7, Windows 8, or Windows 8.1, go to <http://www.lenovo.com/diags> for the latest information on diagnostics for your computer.

To run the Lenovo Solution Center program, see “Software overview” on page 29

For additional information, refer to the Lenovo Solution Center help system.

Note: If you are unable to isolate and repair the problem yourself after running the program, save and print the log files created by the program. You will need the log files when you speak to a Lenovo technical support representative.

UEFI diagnostic program

A UEFI diagnostic program is preinstalled on the computer. It enables you to test memory modules and internal storage devices, view system information, and check and recover bad sectors on internal storage devices.

To run the UEFI diagnostic program, do the following:

1. Turn on the computer. If the computer cannot be turned on, go to “Basic troubleshooting” on page 35. If an error code is displayed, go to Chapter 8 “Symptom-to-FRU Index” on page 67 for error code descriptions and troubleshooting hints.
2. Repeatedly press and release the F10 key when turning on the computer. The main screen of the UEFI diagnostic program is displayed.
3. Follow the instructions on the screen to use the diagnostic program.

The options on the main screen are as follows:

Table 2. Items on the main screen of the UEFI diagnostic program

DIAGNOSTICS	TOOLS
<ul style="list-style-type: none"> • LCD test • Memory - Quick test • Memory - Extended test • Motherboard test • PCI-e test • Storage - Quick test 	<ul style="list-style-type: none"> • System information • Recover bad sectors tool • Generate configuration file • Execute from configuration file • Exit application

Chapter 6. Using the Setup Utility program

The Setup Utility program is used to view and change the configuration settings of your computer, regardless of which operating system you are using. However, the operating system settings might override any similar settings in the Setup Utility program.

Starting the Setup Utility program

To start the Setup Utility program, do the following:

1. Make sure your computer is turned off.
2. Repeatedly press and release the F1 key when turning on the computer. When you hear multiple beeps or see a logo screen, release the F1 key.

Note: If a Power-On Password or an Administrator Password has been set, the Setup Utility program menu will not be displayed until you type the correct password. For more information, see “Using passwords” on page 55.

When the POST detects that the hard disk drive has been removed from your computer or the memory module size has decreased, an error message will be displayed when you start the computer and you will be prompted to do one of the following:

- Press F1 to enter the Setup Utility program.

Note: After you enter the Setup Utility program, select **Save Changes and Exit** at the bottom of the screen. The error message will not be displayed again.

- Press F2 to bypass the error message and log in to the operating system.

Viewing and changing settings

The Setup Utility program menu lists various items about the system configuration. To view or change settings, start the Setup Utility program. See “Starting the Setup Utility program” on page 55. Then, follow the instructions on the screen.

You can use either the keyboard or the mouse to navigate through BIOS menu choices. The keys used to perform various tasks are displayed at the bottom of each screen.

Using passwords

By using the Setup Utility program, you can set passwords to prevent unauthorized access to your computer and data. The following types of passwords are available:

- Power-On Password
- Administrator Password
- Hard Disk Password

You do not have to set any passwords to use your computer. However, using passwords improves computing security. If you decide to set any passwords, read the following sections.

Password considerations

A password can be any combination of up to 64 alphabetic and numeric characters. For security reasons, it is recommended to use a strong password that cannot be easily compromised. To set a strong password, use the following guidelines:

- Have at least eight characters in length
- Contain at least one alphabetic character and one numeric character
- Setup Utility program and hard disk drive passwords are not case sensitive
- Not be your name or your user name
- Not be a common word or a common name
- Be significantly different from your previous passwords

Power-On Password

When a Power-On Password is set, you are prompted to type a valid password each time the computer is turned on. The computer cannot be used until the valid password is typed in.

Administrator Password

Setting an Administrator Password deters unauthorized users from changing configuration settings. If you are responsible for maintaining the configuration settings of several computers, you might want to set an Administrator Password.

When an Administrator Password is set, you are prompted to type a valid password each time you try to access the Setup Utility program. The Setup Utility program cannot be accessed until a valid password is typed in.

If both the Power-On Password and Administrator Password are set, you can type either password. However, you must use your Administrator Password to change any configuration settings.

Hard Disk Password

Setting a Hard Disk Password prevents unauthorized access to the data on the hard disk drive. When a Hard Disk Password is set, you are prompted to type a valid password each time you try to access the hard disk drive.

Notes:

- After you set a Hard Disk Password, your data on the hard disk drive is protected even if the hard disk drive is removed from one computer and installed in another.
- If the Hard Disk Password is forgotten, there is no way to reset the password or recover data from the hard disk drive.

Setting, changing, and deleting a password

To set, change, or delete a password, do the following:

1. Start the Setup Utility program. See “Starting the Setup Utility program” on page 55.
2. From the Setup Utility program main menu, select **Security**.
3. Depending on the password type, select **Set Power-On Password**, **Set Administrator Password**, or **Hard Disk Password**.
4. Follow the instructions on the right side of the screen to set, change, or delete a password.

Note: A password can be any combination of up to 64 alphabetic and numeric characters. For more information, see “Password considerations” on page 56.

Erasing lost or forgotten passwords (clearing CMOS)

This section provides instructions on how to erase lost or forgotten passwords, such as a user password.

To erase a lost or forgotten password, do the following:

1. Remove all media from the drives and turn off all attached devices and the computer. Then, disconnect all power cords from electrical outlets and disconnect all cables that are connected to the computer.
2. Remove the computer cover. See “Removing the computer cover” on page 82.
3. Locate the Clear CMOS /Recovery jumper on the system board. See “Locating parts on the system board” on page 76.
4. Move the jumper from the standard position (pin 1 and pin 2) to the maintenance position (pin 2 and pin 3).
5. Reinstall the computer cover and connect the power cord. See “Completing the parts replacement” on page 124.
6. Turn on the computer and leave it on for approximately 10 seconds. Then, turn off the computer by holding the power button for approximately five seconds.
7. Repeat step 1 through step 2.
8. Move the Clear CMOS /Recovery jumper back to the standard position (pin 1 and pin 2).
9. Reinstall the computer cover and connect the power cord. See “Completing the parts replacement” on page 124.

Enabling or disabling a device

This section provides information on how to enable or disable user access to the following devices:

USB Configuration	Use this option to enable or disable a USB connector. When a USB connector is disabled, the device connected to the USB connector cannot be used.
SATA Configuration	Use this option to enable or disable a SATA connector.

To enable or disable a device, do the following:

1. Start the Setup Utility program. See “Starting the Setup Utility program” on page 55.
2. Depending on the device you want to enable or disable, do one of the following:
 - From the Setup Utility program main menu, select **Devices → South Bridge → USB Configuration** to enable or disable a USB device.
 - From the Setup Utility program main menu, select **Advanced → SATA Configuration** to enable or disable an internal SATA device.
3. Select the desired settings and press Enter.
4. Press F10 to save changes and exit the Setup Utility program. See “Exiting the Setup Utility program” on page 59.

Selecting a startup device

If your computer does not start up from a device such as the disc or hard disk drive as expected, do one of the following to select the startup device you want.

Selecting a temporary startup device

Use this procedure to select a temporary startup device.

Note: Not all discs and hard disk drives are bootable.

1. Turn off your computer.
2. Repeatedly press and release the F12 key when turning on the computer. When the Startup Device Menu window displays, release the F12 key.
3. Select the desired startup device and press Enter. The computer will start up from the device you selected.

Note: Selecting a startup device from the Please select boot device window does not permanently change the startup sequence.

Selecting or changing the startup device sequence

To view or permanently change the configured startup device sequence, do the following:

1. Start the Setup Utility program. See “Starting the Setup Utility program” on page 55.
2. From the Setup Utility program main menu, select **Startup**.
3. Select the devices for the Primary Startup Sequence, the Automatic Startup Sequence, the Error Startup Sequence and Manufacturing Boot Sequence. Read the information displayed on the right side of the screen.
4. Press F10 to save changes and exit the Setup Utility program. See “Exiting the Setup Utility program” on page 59.

Enabling ErP LPS compliance mode and Deep Sx

Lenovo computers meet the eco-design requirements of the ErP Lot 3 regulation. For more information, go to:
<http://www.lenovo.com/ecodeclaration>

You can enable the ErP LPS compliance mode and Deep Sx through the **Devices** menu in the Setup Utility program to reduce the consumption of electricity when your computer is in standby or off mode.

To enable ErP LPS compliance mode and Deep Sx in the Setup Utility program, do the following:

1. Start the Setup Utility program. See “Starting the Setup Utility program” on page 55.
2. From the Setup Utility program main menu, select **Devices → South Bridge**.
3. Select **Deep Sx** and press Enter.
4. Select **Enabled in S4 and S5** and press Enter.
5. Press F10 to save changes and exit the Setup Utility program. Press Enter when prompted to confirm the exit.

Note: When ErP LPS compliance mode and Deep Sx are enabled, you can wake up your computer by doing one of the following:

- Pressing the power switch
- Enabling the wake up on alarm feature

The wake up on alarm feature enables your computer to wake up at a set time. To enable the wake up on alarm feature, do the following:

1. Start the Setup Utility program.
2. From the Setup Utility program main menu, select **Power → Automatic Power On**, and press Enter.
3. Select **Wake Up on Alarm** and press Enter. Then follow the instructions on the screen.

4. Press F10 to save changes and exit the Setup Utility program. Press Enter when prompted to confirm the exit.

- Enabling the after power loss feature

The after power loss feature enables your computer to wake up when the power supply resumes after a sudden loss of electricity. To enable the after power loss feature, do the following:

1. Start the Setup Utility program.
2. From the Setup Utility program main menu, select **Power → After Power Loss**, and press Enter.
3. Select **Power On** and press Enter.
4. Press F10 to save changes and exit the Setup Utility program. Press Enter when prompted to confirm the exit.

Changing the BIOS settings before installing a new operating system

BIOS settings vary by operating system. Change the BIOS settings before installing a new operating system.

To change the BIOS settings, do the following:

1. Start the Setup Utility program. See “Starting the Setup Utility program” on page 55.
2. From the Setup Utility program main menu, select **Exit → OS Optimized Default**.
3. Depending on the operating system to be installed, do one of the following:
 - To install the Windows 8 (64-bit) or Windows 8.1 (64-bit) operating system, select **Enabled**.
 - To install an operating system other than Windows 8 (64-bit) and Windows 8.1 (64-bit), select **Disabled**.
4. Select **Yes** in the window displayed and press Enter to confirm your selection.
5. Press F10 to save changes and exit the Setup Utility program. See “Exiting the Setup Utility program” on page 59.

Exiting the Setup Utility program

After you finish viewing or changing settings, press Esc to return to the Setup Utility program main menu. You might have to press Esc several times. Do one of the following:

- If you want to save the new settings, press F10 to save changes and exit the Setup Utility program.
- If you do not want to save the settings, select **Exit → Discard Changes and Exit**, and then press Enter. When the Reset Without Saving window shows, select **Yes**, and then press Enter to exit the Setup Utility program.
- If you want to return to the default settings, press F9 to load the default settings, and then press F10 to save and exit the Setup Utility program.

Chapter 7. Configuring RAID

This chapter provides instructions on how to install hard disk drives and configure Redundant Array of Independent Disks (RAID) for your computer. Depending on your computer model, RAID can be enabled by Intel Rapid Storage Technology enterprise (RSTe) or the LSI MegaRAID BIOS.

Note: The RAID configuration information described in this chapter is only applicable in the Windows environment. For information about configuring RAID in the Linux environment, contact your Linux software provider.

This chapter provides information about the following topics:

- “Configuring RAID with Intel RSTe” on page 61
- “Quick RAID setup using the LSI MegaRAID BIOS configuration utility ” on page 63

Configuring RAID with Intel RSTe

If your computer comes with Intel RSTe, you can follow the sections below to configure RAID with Intel RSTe.

This section provides information about the following topics:

- “Installing SATA or SAS hard disk drives” on page 61
- “Configuring SATA or SAS RAID functionality with the Intel RSTe configuration utility” on page 62

Installing SATA or SAS hard disk drives

Ensure that your computer has the minimum number of SATA or SAS hard disk drives installed for the following supported levels of RAID:

- RAID Level 0 - Striped disk array
 - A RAID Level 0 hard disk drive group consisting of at least two hard disk drives
 - Supported strip size: 4 KB, 8 KB, 16 KB, 32 KB, 64 KB, or 128 KB
 - Better performance without fault tolerance
- RAID Level 1 - Mirrored disk array
 - A RAID Level 1 hard disk drive group consisting of two hard disk drives
 - Improved reading performance and 100% redundancy
- RAID Level 10 - Striped and mirrored disk array (a combination of RAID Level 0 and RAID Level 1)
 - A RAID Level 10 hard disk drive group consisting of four hard disk drives
 - Supported strip size: 4 KB, 8 KB, 16 KB, 32 KB, or 64 KB
- RAID Level 5 - Block-level striped disk array with distributed parity
 - A RAID Level 5 hard disk drive group consisting of at least three hard disk drives
 - Supported strip size: 4 KB, 8 KB, 16 KB, 32 KB, or 64 KB
 - Better performance and fault tolerance

Ensure that one of the following hard disk drive enablement modules is installed in your computer:

- If zero to four SATA hard disk drives or solid-state drives are installed, no hard disk drive enablement module is needed.

- If five SATA hard disk drives or solid-state drives are installed, the SATA hard disk drive enablement module (one to five hard disk drives) is required.
- If any SAS hard disk drives are installed, the SAS hard disk drive enablement module (one to five hard disk drives) is required.

For more information about the hard disk drive enablement module, refer to “Installing or replacing a hard disk drive enablement module” on page 107.

Configuring SATA or SAS RAID functionality with the Intel RSTe configuration utility

This section describes the information about configuring SATA or SAS RAID functionality with the Intel RSTe configuration utility.

Note: The Intel RSTe configuration utility assumes that your computer is installed with more than one hard disk drive. Therefore, if only one hard disk drive is installed in your computer, the following information does not apply.

This section provides information about the following topics:

- “Entering the Intel RSTe configuration utility” on page 62
- “Creating RAID volumes using the Intel RSTe configuration utility” on page 62
- “Deleting RAID volumes using the Intel RSTe configuration utility” on page 63
- “Resetting hard disk drives to non-RAID” on page 63

Entering the Intel RSTe configuration utility

This section provides instructions on how to enter the Intel RSTe configuration utility.

During the computer startup, follow the instructions on the screen. Press Ctrl+I to enter the Intel RSTe configuration utility.

The following four options are displayed after you enter the Intel RSTe configuration utility:

1. **Create RAID Volume**
2. **Delete RAID Volume**
3. **Reset Disks to Non - RAID**
4. **Exit**

Press the up and down arrow keys to select an option. Press Enter to enter the menu for the selected option. Press Esc to exit the Intel RSTe configuration utility, or select **Exit**, and then press Enter to exit the Intel RSTe configuration utility.

Creating RAID volumes using the Intel RSTe configuration utility

This section provides instructions on how to use the Intel RSTe configuration utility to create RAID volumes.

To create a RAID volume, do the following:

1. Enter the Intel RSTe configuration utility. See “Entering the Intel RSTe configuration utility” on page 62.
2. Press the up and down arrow keys to select **Create RAID Volume**, and then press Enter to view the CREATE VOLUME MENU window.
3. The following five options are displayed. Press the up and down arrow keys to select an option. After you configure an option, press Tab or Enter to go to the next option.
 - a. **Name:** Volume name. You can use the default name or type a preferred name.
 - b. **RAID Level:** You can change the RAID Level to one of the following:

- **RAID Level 0**
 - **RAID Level 1**
 - **RAID Level 10**
 - **RAID Level 5**
- c. **Disks:** Press Enter to enter the SELECT DISKS MENU window. Follow the instructions at the bottom of the menu to select hard disk drives, and then press Enter to complete the configuration.
 - d. **Strip Size:** Press the up and down arrow keys to select a strip size.
 - e. **Capacity:** Customize the capacity of the RAID volume. The default RAID volume is the largest value.
4. Press Enter to finish configuring all the five options. When prompted, press Y to confirm the creation of the new RAID volume.
 5. After the new RAID volume is created, the information about the RAID volume will be displayed under **DISK/VOLUME INFORMATION**, such as ID number, name, RAID level, strip size, volume size, status, and whether it is a bootable volume.

Deleting RAID volumes using the Intel RSTe configuration utility

This section provides instructions on how to use the Intel RSTe configuration utility to delete RAID volumes.

To delete a RAID volume, do the following:

1. Enter the Intel RSTe configuration utility. See “Entering the Intel RSTe configuration utility” on page 62.
2. Press the up and down arrow keys to select **Delete RAID Volume**. Press Enter to enter the DELETE VOLUME MENU window.
3. Press the up and down arrow keys to select the RAID volume that is not needed. Press Del to delete it from the **RAID Volumes** list.
4. When prompted, press Y to confirm the deletion of the selected RAID volume.

Resetting hard disk drives to non-RAID

This section provides instructions on how to reset hard disk drives to non-RAID.

To reset hard disk drives to non-RAID, do the following:

1. Enter the Intel RSTe configuration utility. See “Entering the Intel RSTe configuration utility” on page 62.
2. Press the up and down arrow keys to select **Reset Disks to Non-RAID**. Press Enter to enter the RESET RAID DATA window.
3. Use the up and down arrow keys and the space key to mark individual hard disk drive to be reset, and then press Enter to complete the selection.
4. When prompted, press Y to confirm the reset action.
5. If the hard disk drive you reset is part of a RAID volume, the computer might detect that the RAID volume is degraded. In this case, you are prompted to select a hard disk drive to initiate a rebuild process.
6. Select an available hard disk drive, and then press Enter to initiate the rebuild process.

Note: Press Esc to cancel a rebuild process and keep the RAID volume in the degraded status. In the Main Menu window under **DISK/VOLUME INFORMATION**, you will see the status of the RAID volume is changed to **Degraded**.

Quick RAID setup using the LSI MegaRAID BIOS configuration utility

Notes:

- The LSI MegaRAID SAS adapter and the LSI MegaRAID BIOS configuration utility are only available on some models.
- The following steps in this section are intended to guide you through a quick setup of basic RAID functions with the LSI MegaRAID SAS adapter. For advanced setup and configuration

using this adapter, refer to the complete *MegaRAID SAS Software User Guide* that is available at http://support.lenovo.com/en_US/guides-and-manuals/detail.page?DocID=UM007543.

This section provides information about the following topics:

- “Installing SATA or SAS hard disk drives” on page 64
- “Entering the LSI MegaRAID BIOS configuration utility” on page 65
- “Creating RAID volumes using the LSI MegaRAID BIOS configuration utility” on page 65
- “Deleting RAID volumes using the LSI MegaRAID BIOS configuration utility” on page 66
- “Setting the hot spare hard disk drive” on page 66

Installing SATA or SAS hard disk drives

Ensure that your computer has the minimum number of SATA or SAS hard disk drives installed for the following supported levels of RAID:

- RAID Level 0 - Striped disk array
 - A RAID Level 0 hard disk drive group consisting of at least one hard disk drive
 - Supported strip size: 8 KB to 1 MB
 - Better performance without fault tolerance
- RAID Level 00 - Spanned hard disk drive group with a series of RAID 0 hard disk drive groups
 - A RAID Level 00 hard disk drive group consisting of two or four hard disk drives
 - Supported strip size: 8 KB to 1 MB
 - Better performance without fault tolerance
- RAID Level 1 - Mirrored disk array
 - A RAID Level 1 hard disk drive group consisting of two or four hard disk drives
 - Improved read performance and 100% redundancy
- RAID Level 10 - A combination of RAID Level 0 and RAID Level 1
 - A RAID Level 10 hard disk drive group consisting of four hard disk drives
 - Data being striped across hard disk drive groups
 - Provides both high data transfer rates and complete data redundancy
- RAID Level 5 - Block-level striped disk array with distributed parity
 - A RAID Level 5 hard disk drive group consisting of at least three hard disk drives
 - Supported strip size: 8 KB to 1 MB
 - Better performance and fault tolerance
 - RAID Level 5 might not be available on all models of LSI MegaRAID adapter
- RAID Level 6 - Block-level striped disk array with dual distributed parity
 - A RAID Level 6 hard disk drive group consisting of at least four hard disk drives
 - Supported strip size: 8 KB to 1 MB
 - Better performance and fault tolerance that can stand up to loss of two hard disk drives
 - RAID Level 6 might not be available on all models of LSI MegaRAID adapter

Ensure that the LSI MegaRAID SAS adapter card is installed in your computer, and that the hard disk drives are connected to this adapter card and not to the connectors on the system board.

Entering the LSI MegaRAID BIOS configuration utility

This section provides instructions on how to enter the LSI MegaRAID BIOS configuration utility.

To enter the LSI MegaRAID BIOS configuration utility, do the following:

1. During the computer startup, follow the instructions on the screen.
2. Press Ctrl+H to enter the CONTROLLER SELECTION window.
3. Select the controller you want to configure, and then click **Start** to enter the LSI MegaRAID BIOS configuration utility.

Creating RAID volumes using the LSI MegaRAID BIOS configuration utility

This section provides instructions on how to create RAID volumes using the LSI MegaRAID BIOS configuration utility.

To create RAID volumes using the LSI MegaRAID BIOS configuration utility, do the following:

1. Click **Configuration Wizard** on the WebBIOS main screen to enter the Choosing the Configuration Type window.
2. Press the up and down arrow keys to select one of the three configuration types:
 - **Clear Configuration:** Clear the existing configuration.
 - **New Configuration:** Clear the existing configuration and create new configuration.
 - **Add Configuration:** Retain the existing storage configuration and add new hard disk drives. The new configuration will not cause any data loss.
3. Select **Add Configuration**, and then click **Next**. The following two options are displayed in the Configuration Method window.
 - **Manual Configuration:** Manually create hard disk drive groups and virtual hard disk drives, and set parameters.
 - **Automatic Configuration:** Automatically create an optimal RAID configuration.
4. Select **Manual Configuration**, and then click **Next**. The Drive Group Definition window is displayed. To create hard disk drive groups, do the following:
 - a. Select one or more hard disk drives for the group (keep pressing Ctrl while selecting more than one hard disk drive).
 - b. Click **Add To Array** to move the selected hard disk drives to **Drive Groups**.
 - c. Click **Accept DG** to create the hard disk drive group.
 - d. Repeat the above steps if you want to create more than one hard disk drive group.
5. Click **Next**. The Span Definition window is displayed. Select the hard disk drive group that you want to add to a span, and then click **Add to SPAN**. Repeat this step until you have selected all the hard disk drive groups you want.
6. Click **Next**. The Virtual Drive Definition window is displayed. Change the virtual hard disk drive options from the default settings listed on the screen to the settings you want. Click **Accept**, and then follow the instructions on the screen to customize your settings.
7. Click **Next**, and the Preview window is displayed.
8. Verify your settings, and then click **Accept**.
9. Click **Yes** to save the configuration.

Deleting RAID volumes using the LSI MegaRAID BIOS configuration utility

This section provides instructions on how to delete RAID volumes using the LSI MegaRAID BIOS configuration utility.

To delete RAID volumes using the LSI MegaRAID BIOS configuration utility, do the following:

1. Enter the LSI MegaRAID BIOS configuration utility. See “Entering the LSI MegaRAID BIOS configuration utility” on page 65.
2. Click the virtual hard disk drives you want to delete, and then the Virtual Drive window is displayed.
3. Click **Delete**, and then click **Go**.
4. Click **Yes** to save your changes.

Setting the hot spare hard disk drive

This section provides instructions on how to set the hot spare hard disk drive.

To set the hot space hard disk drive, do the following:

1. Enter the LSI MegaRAID BIOS configuration utility. See “Entering the LSI MegaRAID BIOS configuration utility” on page 65.
2. Click the hard disk drive you want to set as the hot spare hard disk drive. The Drive window is displayed.
3. Select **Make Global HSP** or **Make Dedicated HSP**, and then click **Go**.
4. The main screen of the LSI MegaRAID BIOS configuration utility is displayed, and the hard disk drive you selected is listed as a hot spare hard disk drive in the right pane.

Chapter 8. Symptom-to-FRU Index

The Symptom-to-FRU index lists error symptoms and possible causes. The most likely cause is listed first. Always begin with Chapter 4 “General Checkout” on page 33. This index can also be used to help you decide which FRUs to have available when servicing a computer. If you are unable to correct the problem using this index, go to “Undetermined problems” on page 71.

Notes:

- If you have both an error message and an incorrect audio response, diagnose the error message first.
- If you cannot run the diagnostic tests or you get a diagnostic error message when running a test, but did receive a POST error message, diagnose the POST error message first.
- If you did not receive any error message, look for a description of your error symptoms in the first part of this index.

Hard disk drive boot error

A hard disk drive boot error can have the following causes.

Error	FRU/Action
The start-up drive is not in the boot sequence in configuration.	Check the configuration and ensure the start-up drive is in the boot sequence.
No operating system installed on the boot drive.	Install an operating system on the boot drive.
The boot sector on the start-up drive is corrupted.	The drive must be formatted. Do the following: <ol style="list-style-type: none">1. Attempt to back up the data on the failing hard disk drive.2. Using the operating system programs, format the hard disk drive.
The drive is defective.	Replace the hard disk drive.

Power Supply Problems

If you suspect a power problem, use the following procedures.

Check/Verify	FRU/Action
Check the following for proper installation. <ul style="list-style-type: none">• Power cord• On/Off switch connector• On/Off switch power supply connector• System board power supply connectors• Microprocessor(s) connection	Reseat connectors
Check the power cord for continuity.	Power cord
Check the turn on switch for continuity.	Turn on switch

Beep symptoms

Beep symptoms are tones or a series of tones separated by pauses (intervals without sound) during POST.

The following tables describes beep symptoms.

Beep Symptom	FRU/Action
2 short beeps CMOS setting error	Perform the following actions in order. <ol style="list-style-type: none"> 1. Start the Setup Utility program and press F10 to save and exit. See Chapter 6 “Using the Setup Utility program” on page 55. 2. Start the Setup Utility program and press F9 to load defaults and then press F10 to save and exit. 3. Perform a Boot block recovery. See “Recovering from a POST/BIOS update failure” on page 129.
1 long and 2 short beeps Monitor or video adapter card error	Perform the following actions in order. <ol style="list-style-type: none"> 1. Make sure the monitor is properly connected to the computer. 2. Replace the video adapter card (if present). 3. Replace the system board.
1 long and 3 short beeps Keyboard error	Perform the following actions in order. <ol style="list-style-type: none"> 1. Make sure the keyboard is properly connected to the keyboard connector. 2. Replace the keyboard. 3. Replace the system board.
1 long and 9 short beeps BIOS ROM error	Perform the following actions in order. <ol style="list-style-type: none"> 1. Start the Setup Utility program and press F9 to load defaults and then press F10 to Save and exit. See Chapter 6 “Using the Setup Utility program” on page 55. 2. Perform a Boot block recovery. See “Recovering from a POST/BIOS update failure” on page 129. 3. Replace the system board.
1-3-3-1 short beeps DRAM memory error	Perform the following actions in order. <ol style="list-style-type: none"> 1. Make sure the memory module(s) are properly seated in the connector(s). 2. Replace the memory module(s). 3. Replace the system board.

POST error codes

Each time you Turn on the system, it performs a series of tests that check the operation of the system and some options. This series of tests is called the *Power-On Self-Test*, or *POST*. POST does the following operations.

- Checks some basic system-board operations
- Checks the memory operation
- Starts the video operation
- Verifies that the boot drive is working

If the POST detects a problem, an error message appears on the screen. A single problem can cause several error messages to appear. When you correct the cause of the first error message, the other error messages probably will not appear on the screen the next time you turn on the system.

POST Error Message	Description/Action
CMOS battery failed	The CMOS battery is no longer functional. Replace the battery.
CMOS checksum error - defaults loaded	Checksum of CMOS is incorrect. The computer loads the default configuration settings. This error might indicate that CMOS has become corrupt due to a weak CMOS battery.
CPU at nnnn	nnnn is the running speed of the microprocessor.
Press Esc to skip memory test	Pressing Esc skips the full memory test
HARD DISK INSTALL FAILURE	Cannot find or initialize the hard disk drive controller or the drive. Make sure the hard disk drive is correctly installed. If no hard disk drives are installed, make sure the hard disk drive selection in Setup is set to NONE.
Keyboard error or no keyboard present	Cannot initialize the keyboard. Make sure the keyboard is properly connected to the computer and that no keys are held pressed during POST. To purposely configure the computer without a keyboard, set the error halt condition in Setup to HALT ON ALL, BUT KEYBOARD. The BIOS then ignores the missing keyboard during POST.
Memory Test:	This message displays during a full memory test, counting down the memory areas being tested.
Memory test fail	If POST detects an error during memory testing, additional information appears. This information gives specifics about the type and location of the memory error.
Press TAB to show POST screen	Pressing the TAB key permits the user to toggle between the default POST display screen and a custom POST display screen.
Error: Non-System disk or disk error Replace and press any key when ready	The BIOS was unable to find a suitable boot device. Make sure the boot drive is properly connected to the computer. Make sure you have bootable media.

Miscellaneous error messages

Message/Symptom	FRU/Action
Changing display colors	Display/Monitor
Computer will <i>not</i> turn off. See "Power Supply Problems" on page 67.	<ol style="list-style-type: none"> 1. Power button 2. System board 3. Riser card, if installed.

Message/Symptom	FRU/Action
Computer will <i>not</i> RPL from server	<ol style="list-style-type: none"> 1. Ensure that network is in startup sequence as first device or first device after diskette. 2. Ensure that network adapter is enabled for RPL. 3. Network adapter (Advise network administrator of new MAC address)
Computer will <i>not</i> perform a Wake On LAN® (if applicable)	<ol style="list-style-type: none"> 1. Check power supply and signal cable connections to network adapter. 2. Ensure that the operating system settings are set to enable Wake on LAN. 3. Ensure Wake On LAN feature is enabled in Setup/Configuration (see “Starting the Setup Utility program” on page 55) 4. Ensure network administrator is using correct MAC address. 5. Ensure no interrupt or I/O address conflicts. 6. Network adapter (advise network administrator of new MAC address) 7. Replace system board
Dead computer. See “Power Supply Problems” on page 67.	<ol style="list-style-type: none"> 1. Power supply 2. System board
Diskette drive in-use light remains on or does not light when drive is active.	<ol style="list-style-type: none"> 1. Diskette drive 2. System board 3. Diskette drive cable
Blank screen except for flashing cursor.	<ol style="list-style-type: none"> 1. System board 2. Primary hard disk drive 3. Hard disk drive cable
Incorrect memory size during POST	<ol style="list-style-type: none"> 1. Run the memory tests. 2. Memory module 3. System board
"Insert a Diskette" icon appears with a known-good diagnostics diskette in the first 3.5-inch diskette drive.	<ol style="list-style-type: none"> 1. System board 2. Diskette drive cable 3. Network adapter
Intensity or color varies from left to right of characters and color bars	<ol style="list-style-type: none"> 1. Display 2. Video adapter (if present) 3. System board
No power or fan not running	<ol style="list-style-type: none"> 1. See “Power Supply Problems” on page 67. 2. Replace system board
Non-system disk or disk error-type message with a known-good diagnostic diskette.	<ol style="list-style-type: none"> 1. Diskette drive 2. System board 3. Diskette drive cable
Other display symptoms not listed above (including blank or illegible display)	<ol style="list-style-type: none"> 1. Display 2. System board
Turn on indicator or hard disk drive in-use light not on, but computer works correctly	<ol style="list-style-type: none"> 1. Power button/LED assembly 2. System board

Message/Symptom	FRU/Action
Printer problems	<ol style="list-style-type: none"> 1. Printer 2. System board
Program loads from the hard disk with a known-good diagnostics diskette in the first 3.5-inch diskette drive	<ol style="list-style-type: none"> 1. Run the Setup Utility program and check Startup sequence. 2. Diskette drive 3. Diskette drive cable 4. System board 5. Power supply
RPL computer cannot access programs from its own hard disk.	<ol style="list-style-type: none"> 1. If network administrator is using LCCM Hybrid RPL, check startup sequence: <ol style="list-style-type: none"> a. First device - network b. Second device - hard disk 2. Hard disk drive
RPL computer does not RPL from server	<ol style="list-style-type: none"> 1. Check startup sequence. 2. Check the network adapter LED status.
Serial or parallel port device failure (system board port)	<ol style="list-style-type: none"> 1. External device self-test OK? 2. External device 3. Cable 4. System board
Serial or parallel port device failure (adapter port)	<ol style="list-style-type: none"> 1. External device self-test OK? 2. External device 3. Cable 4. Alternate adapter 5. System board
Some or all keys on the keyboard do not work	<ol style="list-style-type: none"> 1. Keyboard 2. Keyboard cable 3. System board

Undetermined problems

This section provides instructions on how to find out the failing devices or adapters.

1. Turn off the computer.
2. Remove or disconnect the following components (if installed) one at a time.
 - a. External devices (modem, printer, or mouse)
 - b. Any adapters
 - c. Memory modules
 - d. Extended video memory
 - e. External Cache
 - f. External Cache RAM
 - g. Hard disk drive
 - h. Diskette drive
3. Turn on the computer to re-test the system.
4. Repeat steps 1 through 3 until you find the failing device or adapter.

If all devices and adapters have been removed, and the problem continues, replace the system board.

Chapter 9. Locations

This chapter introduces the locations of the computer hardware components.

Locating connectors, controls, and indicators on the front of your computer

Figure 1 “Front connector, control, and indicator locations” on page 73 shows the locations of the connectors, controls, and indicators on the front of your computer.

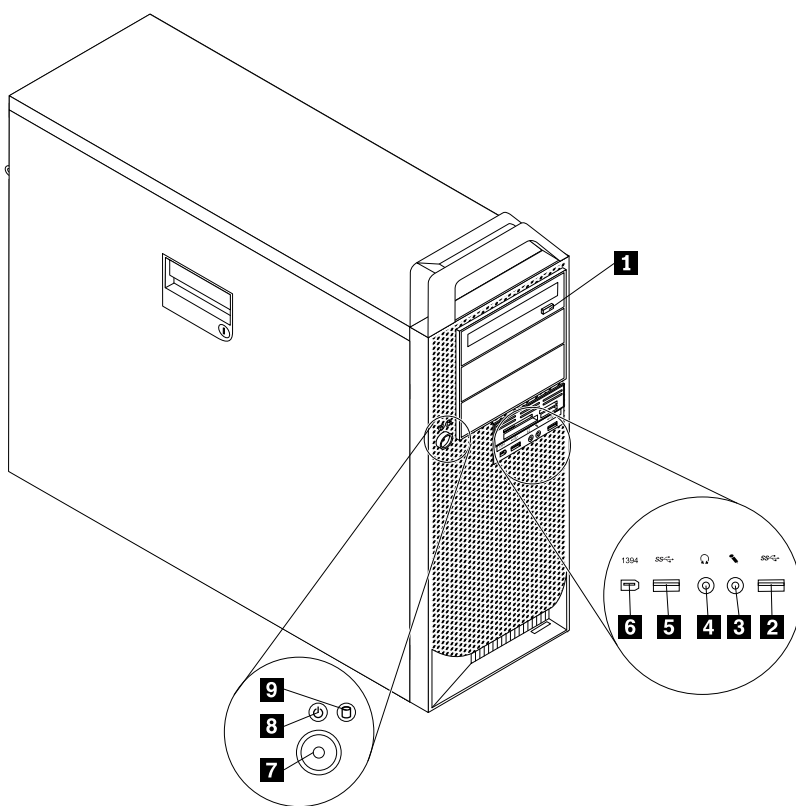

Figure 1. Front connector, control, and indicator locations

- | | |
|---|--|
| 1 Optical drive eject/close button | 2 USB 3.0 connector |
| 3 Microphone connector | 4 Headphone connector |
| 5 USB 3.0 connector | 6 1394 connector (available on some models) |
| 7 Power button | 8 Power indicator |
| 9 Hard disk drive activity indicator | |

Locating connectors on the rear of your computer

Figure 2 “Rear connector locations” on page 74 shows the locations of the connectors on the rear of your computer. Some connectors on the rear of your computer are color-coded to help you determine where to connect the cables on your computer.

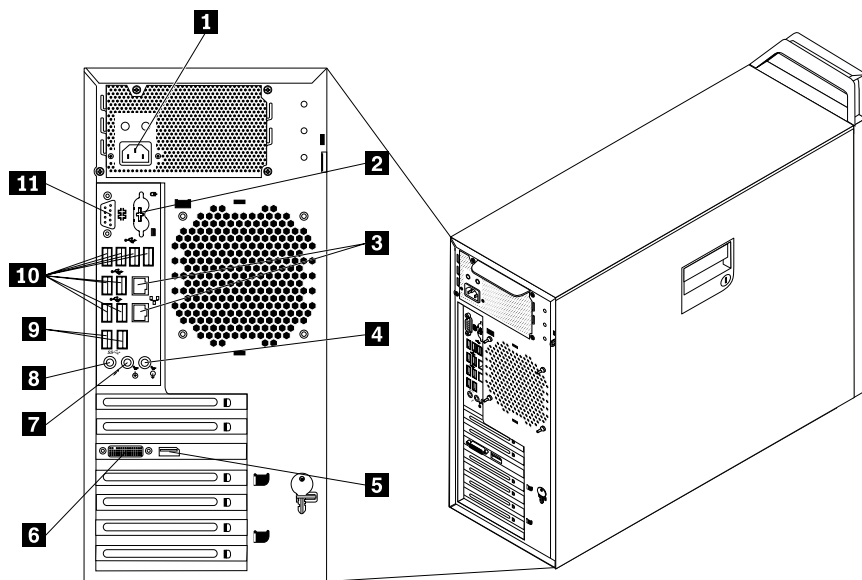

Figure 2. Rear connector locations

- | | |
|--|--|
| 1 Power cord connector | 2 PS/2 keyboard and mouse connectors (optional) |
| 3 Ethernet connectors (2) | 4 Audio line-in connector |
| 5 DVI monitor connector, DisplayPort® connector, or mini DisplayPort® connector (number and location vary by model) | 6 DVI connector, DisplayPort connector, or mini DisplayPort connector (number and location vary by model) |
| 7 Audio line-out connector | 8 Microphone connector |
| 9 USB 3.0 connectors (2) | 10 USB 2.0 connectors (8) |
| 11 Serial connector | |

Locating major FRUs and CRUs

Figure 3 “Locating major FRUs and CRUs” on page 75 shows the locations of the major FRUs and CRUs in the computer. To remove the computer cover, see “Removing the computer cover” on page 82.

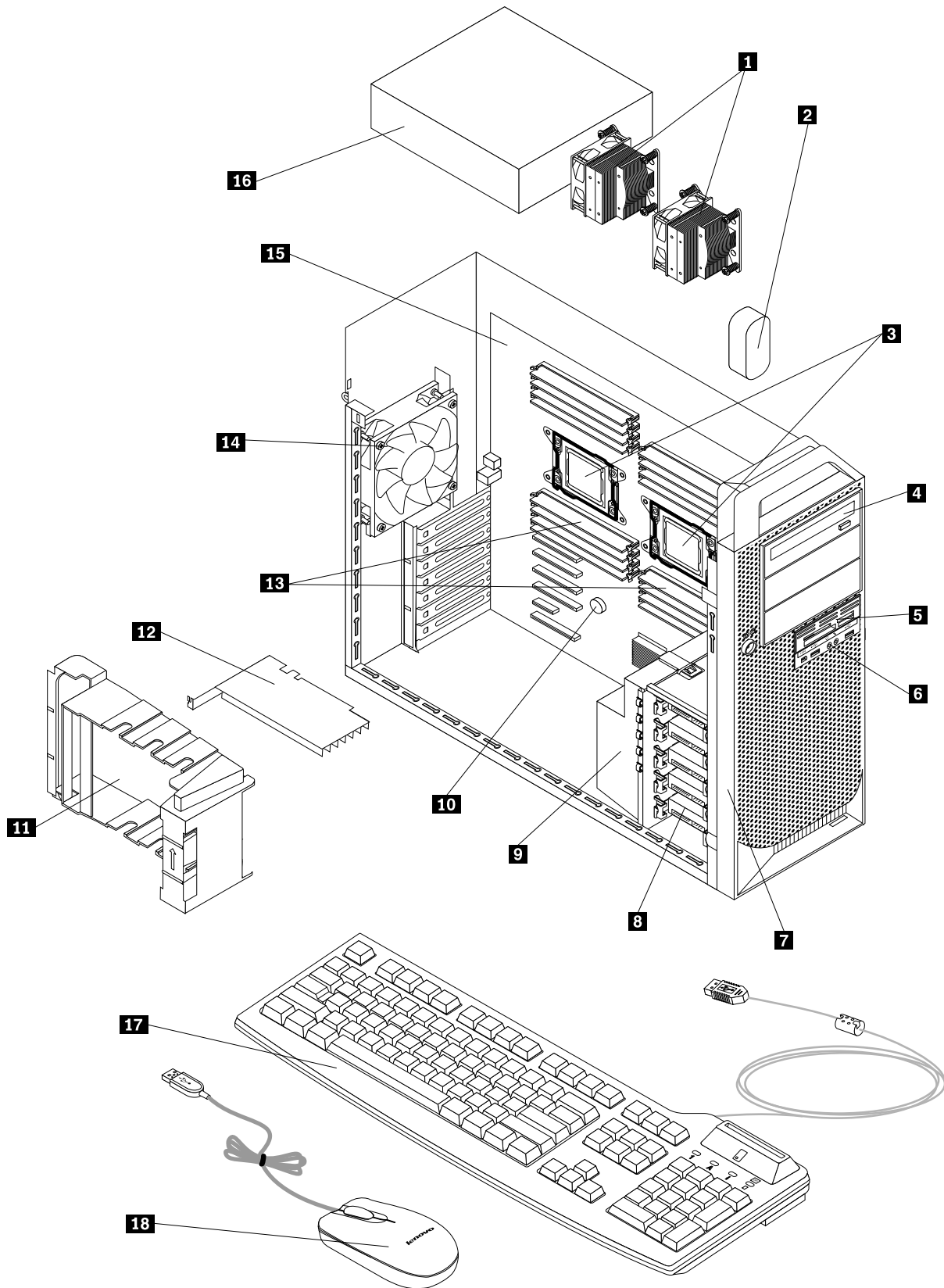

Figure 3. Locating major FRUs and CRUs

The following table lists the major FRUs shown in Figure 3 “Locating major FRUs and CRUs” on page 75 and identifies which FRUs also are self-service CRUs or optional-service CRUs.

Notes:

- Self-service CRUs: These CRUs unplug or are secured by no more than two screws. Examples of these types of CRUs include the keyboard, the mouse, any USB device, and the power cord. Other self-service CRUs depending on product design might include memory modules, adapter cards, hard disk drives, and optical drives.
- Optional-service CRUs: These CRUs are isolated parts within the computer and are concealed by an access panel that is typically secured by more than two screws. Once the access panel is removed, the specific CRU is visible.

Number	FRU description	Self-service CRU	Optional-service CRU
1	Heat sink and fan assembly	No	Yes
2	Internal speaker	No	Yes
3	Microprocessor	No	No
4	Optical drive (in some models)	Yes	No
5	Card reader (in some models)	Yes	No
6	Front audio and USB assembly	No	Yes
7	Front bezel	Yes	Yes
8	Hard disk drives	Yes	No
9	Hard disk drive fan assembly	Yes	No
10	Battery	Yes	No
11	Memory module	Yes	No
12	Peripheral Component Interconnect (PCI) card retainer	Yes	No
13	PCI card	Yes	No
14	Rear fan assembly	No	Yes
15	System board	No	No
16	Power supply assembly	No	No
17	Keyboard	Yes	No
18	Mouse	Yes	No

Looking up FRU information

For detailed FRU information, such as the FRU part numbers and supported computer models, go to: <http://www.lenovo.com/serviceparts-lookup>

Locating parts on the system board

Figure 4 “System board part locations” on page 77 shows the locations of the parts on the system board.

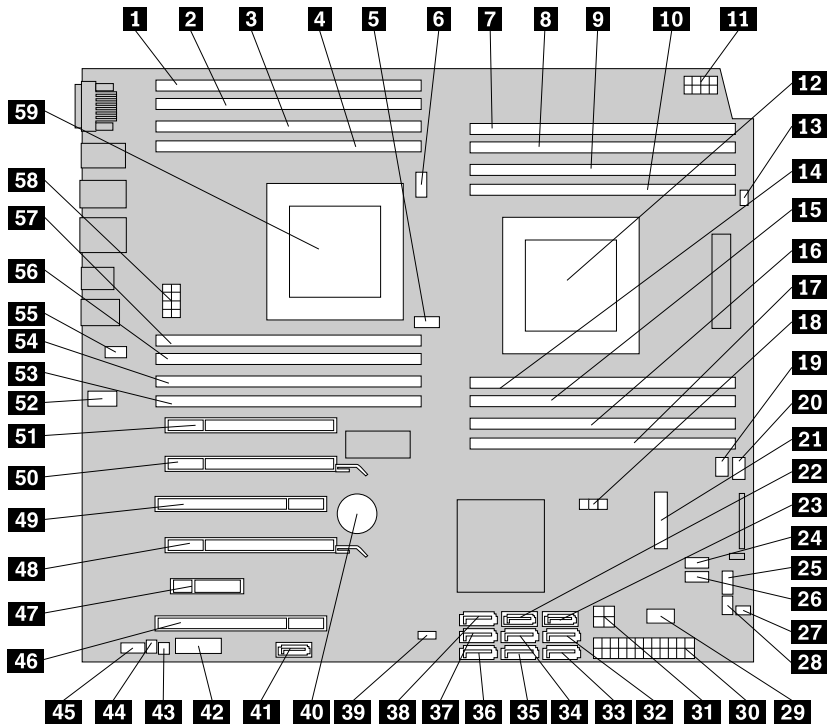

Figure 4. System board part locations

- | | |
|---|--|
| 1 Microprocessor 2 memory slot 3 (DIMM3) | 2 Microprocessor 2 memory slot 7 (DIMM7) |
| 3 Microprocessor 2 memory slot 4 (DIMM4) | 4 Microprocessor 2 memory slot 8 (DIMM8) |
| 5 Microprocessor 2 memory cooler connector | 6 Microprocessor 2 fan connector |
| 7 Microprocessor 1 memory slot 1 (DIMM1) | 8 Microprocessor 1 memory slot 5 (DIMM5) |
| 9 Microprocessor 1 memory slot 2 (DIMM2) | 10 Microprocessor 1 memory slot 6 (DIMM6) |
| 11 Microprocessor 1 12 volt power connector | 12 Microprocessor 1 |
| 13 Microprocessor 1 fan connector | 14 Microprocessor 1 memory slot 8 (DIMM8) |
| 15 Microprocessor 1 memory slot 4 (DIMM4) | 16 Microprocessor 1 memory slot 7 (DIMM7) |
| 17 Microprocessor 1 memory slot 3 (DIMM3) | 18 Clear CMOS (Complementary Metal Oxide Semiconductor) /Recovery jumper |
| 19 Front fan connector | 20 Microprocessor 1 memory cooler connector |
| 21 Mini PCI express / mSATA SSD card slot | 22 SATA connector 4 |
| 23 SATA connector 3 | 24 Internal USB 2.0 connector (for connecting the media card reader) |
| 25 Front panel connector | 26 Front USB 2.0 connector (for connecting the front USB 2.0 ports if applicable) |
| 27 Hard disk drive enablement module connector | 28 Auxiliary LED connector |
| 29 Internal USB 2.0 connector | 30 Auxiliary power connector |
| 31 12 volt power connector | 32 SATA connector 2 |
| 33 SATA connector 1 | 34 Hard disk drive connector 5 |
| 35 Hard disk drive connector 4 | 36 Hard disk drive connector 1 |

37 Hard disk drive connector 2

39 Cover presence switch connector (Intrusion switch connector)

41 eSATA connector

43 Thermal sensor

45 Front audio connector

47 PCI Express x4 card slot

49 PCI card slot

51 PCI Express x4 card slot (x16 mechanical) (also supporting 400 GB Intel Solid-State Drive 910 Series)

53 Microprocessor 2 memory slot 1 (DIMM1)

55 PS/2 connector

57 Microprocessor 2 memory slot 6 (DIMM6)

59 Microprocessor 2

38 Hard disk drive connector 3

40 Battery

42 Front USB 3.0 connector (for connecting the front USB 3.0 ports if applicable)

44 Internal speaker connector

46 PCI card slot

48 PCI Express x16 card slot (also supporting Intel Xeon Phi Coprocessor 3120A PCI Express card)*

50 PCI Express x16 card slot

52 Rear fan connector

54 Microprocessor 2 memory slot 5 (DIMM5)

56 Microprocessor 2 memory slot 2 (DIMM2)

58 Microprocessor 2 12 volt power connector

Note: * denotes that this card slot can support up to Kepler K2000 Graphic Card or Nvidia Quadro 2000 Graphic Card.

Locating internal drives

Internal drives are devices that your computer uses to read and store data. You can add drives to your computer to increase storage capacity and enable your computer to read other types of media. Internal drives are installed in bays. In this manual, the bays are referred to as bay 1, bay 2, and so on.

When installing or replacing an internal drive, it is important to note the type and size of the drive that you can install or replace in each bay and correctly connect the cables to the drive installed. Refer to the appropriate section in “Installing or replacing hardware” on page 81 for instructions on how to install or replace internal drives for your computer.

Figure 5 “Drive bay locations” on page 79 shows the locations of the drive bays.

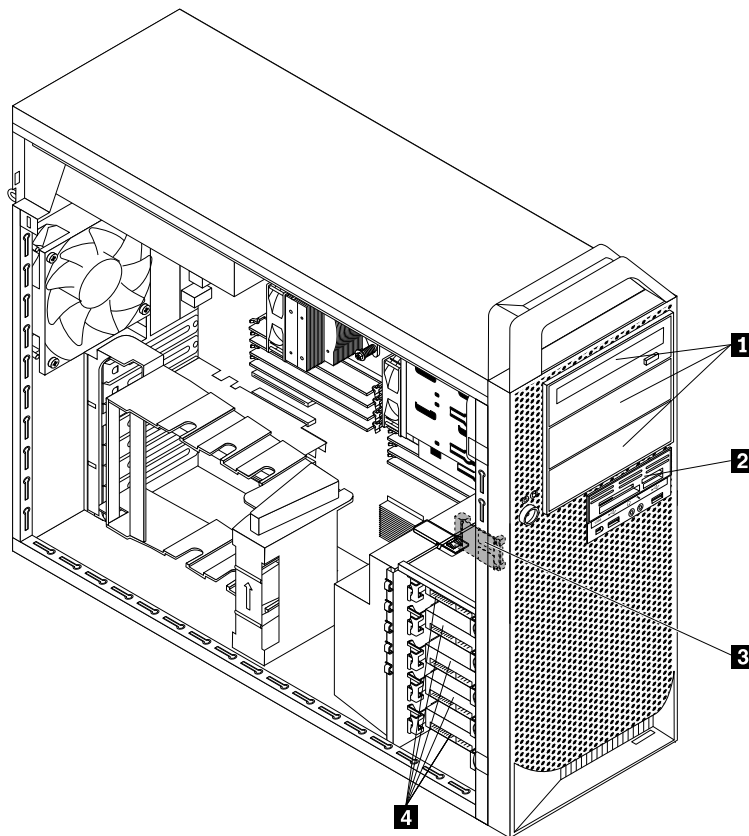

Figure 5. Drive bay locations

- 1** Optical drive bays 1 to 3 (with optical drives installed in some models)
- 2** Card reader drive bay
- 3** mSATA solid-state drive bay (with an mSATA solid-state drive installed in some models)
- 4** Hard disk drive bays 1 to 5 (with hard disk drives installed)

Chapter 10. Replacing FRUs

This chapter provides information about the FRU replacement instructions.

Important

Be sure to read and understand Chapter 2 “Safety information” on page 3 before replacing any FRU. These precautions and guidelines will help you work safely.

Note: FRU replacements are to be done only by trained service technicians.

Handling static-sensitive devices

Do not open the static-protective package containing the new part until the defective part has been removed from the computer and you are ready to install the new part. Static electricity, although harmless to you, can seriously damage computer components and parts.

When you handle parts and other computer components, take these precautions to avoid static-electricity damage:

- Limit your movement. Movement can cause static electricity to build up around you.
- Always handle parts and other computer components carefully. Handle PCI cards, memory modules, system boards, and microprocessors by the edges. Never touch any exposed circuitry.
- Prevent others from touching the parts and other computer components.
- Before you replace a new part, touch the static-protective package containing the part to a metal expansion-slot cover or other unpainted metal surface on the computer for at least two seconds. This reduces static electricity in the package and your body.
- When possible, remove the new part from the static-protective packaging, and install it directly in the computer without setting the part down. When this is not possible, place the static-protective package that the part came in on a smooth, level surface and place the part on it.
- Do not place the part on the computer cover or other metal surface.

Installing or replacing hardware

This section provides instructions on how to install or replace hardware for your computer. You can expand the capabilities of your computer and maintain your computer by installing or replacing hardware.

Attention:

Do not open your computer or attempt any repair before reading and understanding the “Important Safety Information” on page 1.

Notes:

1. Use only computer parts provided by Lenovo.
2. When installing or replacing an option, use the appropriate instructions in this section along with the instructions that come with the option.

Installing external options

You can connect external options to your computer, such as external speakers, a printer, or a scanner. For some external options, you must install additional software in addition to making the physical connection. When installing an external option, see “Locating connectors, controls, and indicators on the front of your

computer” on page 73 and “Locating connectors on the rear of your computer” on page 74 to identify the required connector. Then, use the instructions that come with the option to help you make the connection and install any software or device drivers that are required for the option.

Removing the computer cover

Attention:

Do not open your computer or attempt any repair before reading and understanding the “Important Safety Information” on page 1.

This section provides instructions on how to remove the computer cover.

CAUTION:



Before you open the computer cover, turn off the computer and wait several minutes until the computer is cool.

To remove the computer cover, do the following:

1. Remove any media from the drives and turn off all attached devices and the computer.
2. Disconnect all power cords from electrical outlets.
3. Disconnect the power cords, Input/Output cables, and any other cables that are connected to the computer. See “Locating connectors, controls, and indicators on the front of your computer” on page 73 and “Locating connectors on the rear of your computer” on page 74.
4. Remove any locking device that secures the computer cover, such as a padlock or an integrated cable lock.

5. Disengage the cover latch **1** and remove the cover. Place the cover on a flat surface.

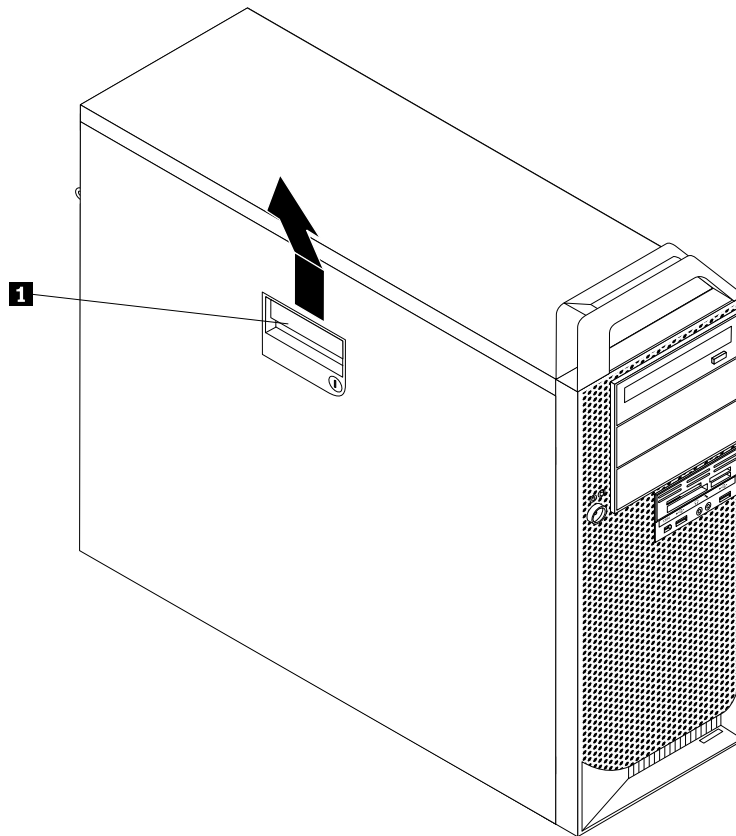

Figure 6. Removing the computer cover

Removing and reinstalling the front bezel

Attention:

Do not open your computer or attempt any repair before reading and understanding the “Important Safety Information” on page 1.

This section provides instructions on how to remove and reinstall the front bezel.

To remove and reinstall the front bezel, do the following:

1. Turn off the computer and disconnect all power cords from electrical outlets.
2. Remove the computer cover. See “Removing the computer cover” on page 82.

3. Remove the front bezel by releasing the two plastic tabs on the left side and pivoting the front bezel outward.

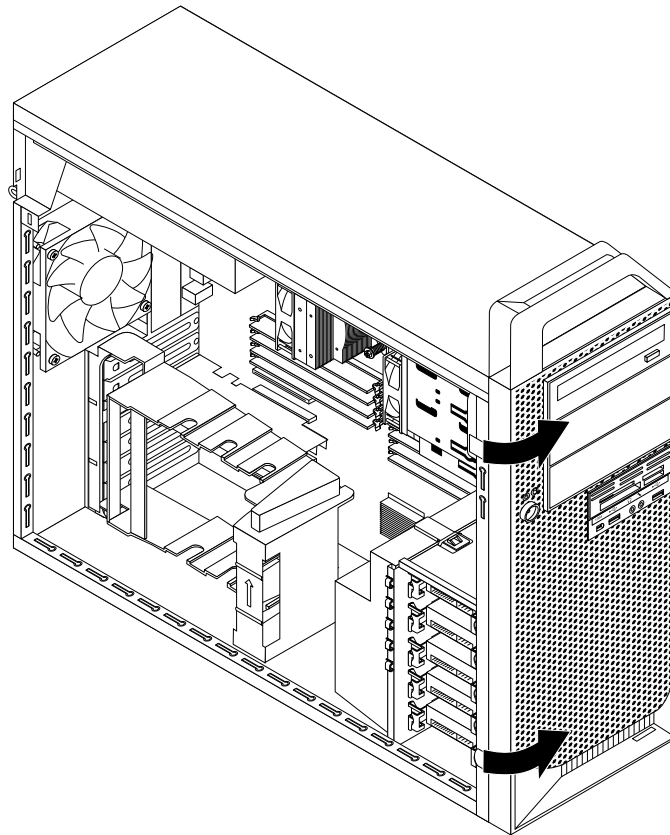

Figure 7. Removing the front bezel

4. To reinstall the front bezel, align the three plastic tabs on the right side of the front bezel with the corresponding holes in the chassis, and then pivot the front bezel inwards until the two plastic tabs snaps into position on the left side.

What to do next:

- To work with another piece of hardware, go to the appropriate section.
- To complete the installation or replacement, go to “Completing the parts replacement” on page 124.

Installing or replacing a PCI card

Attention:

Do not open your computer or attempt any repair before reading and understanding the “Important Safety Information” on page 1.

This section provides instructions on how to install or replace a PCI card, an Intel Solid-State Drive 910 Series or an Intel Xeon Phi Coprocessor 3120A PCI Express card. Your computer has two standard PCI card slots, two PCI Express x4 card slots, and two PCI Express x16 graphics card slots.

Note: If you want to use an NVIDIA compute card, ensure that your computer also has an NVIDIA graphics card installed.

To install or replace a PCI card, do the following:

1. Turn off the computer and disconnect all power cords from electrical outlets.
2. Remove the computer cover. See “Removing the computer cover” on page 82.
3. Open the PCI card retainer by lifting the retainer and then pivoting it out.

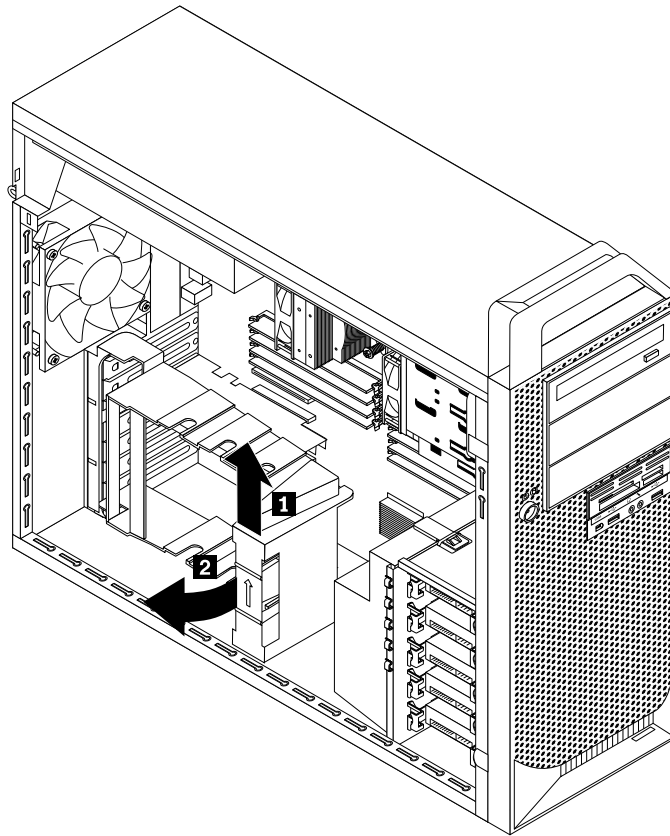

Figure 8. Opening the PCI card retainer

4. Depending on whether you are installing or replacing a PCI card, do one of the following:
 - If you are installing a PCI card, remove the appropriate metal card slot cover.
 - If you are replacing an old PCI card, grasp the old card that is currently installed and gently pull it out of the card slot.

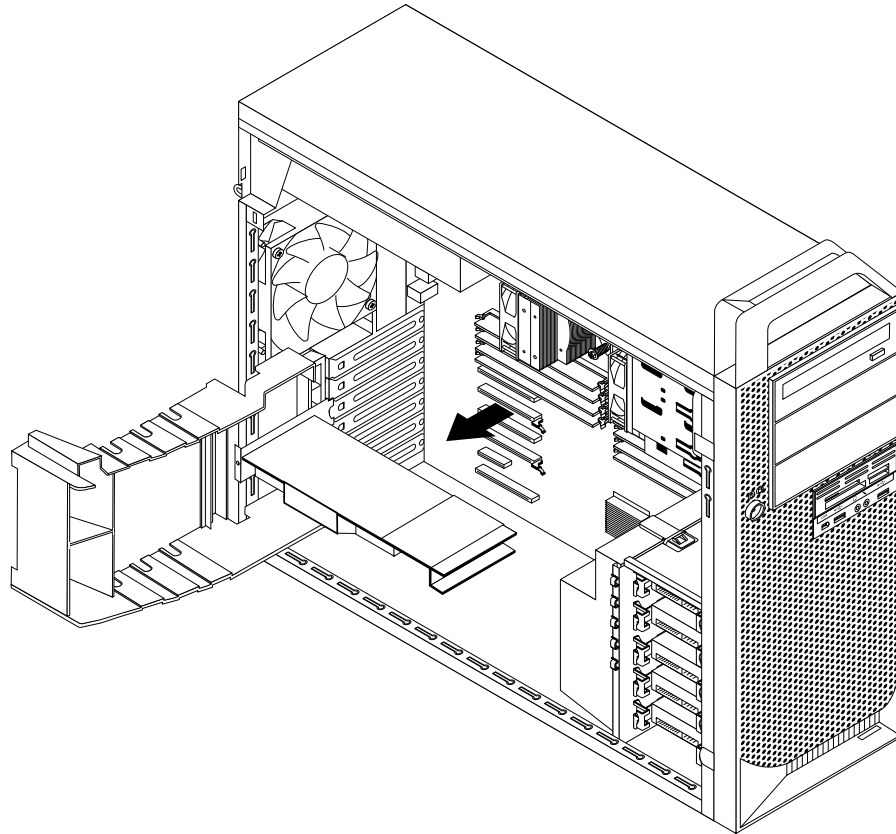
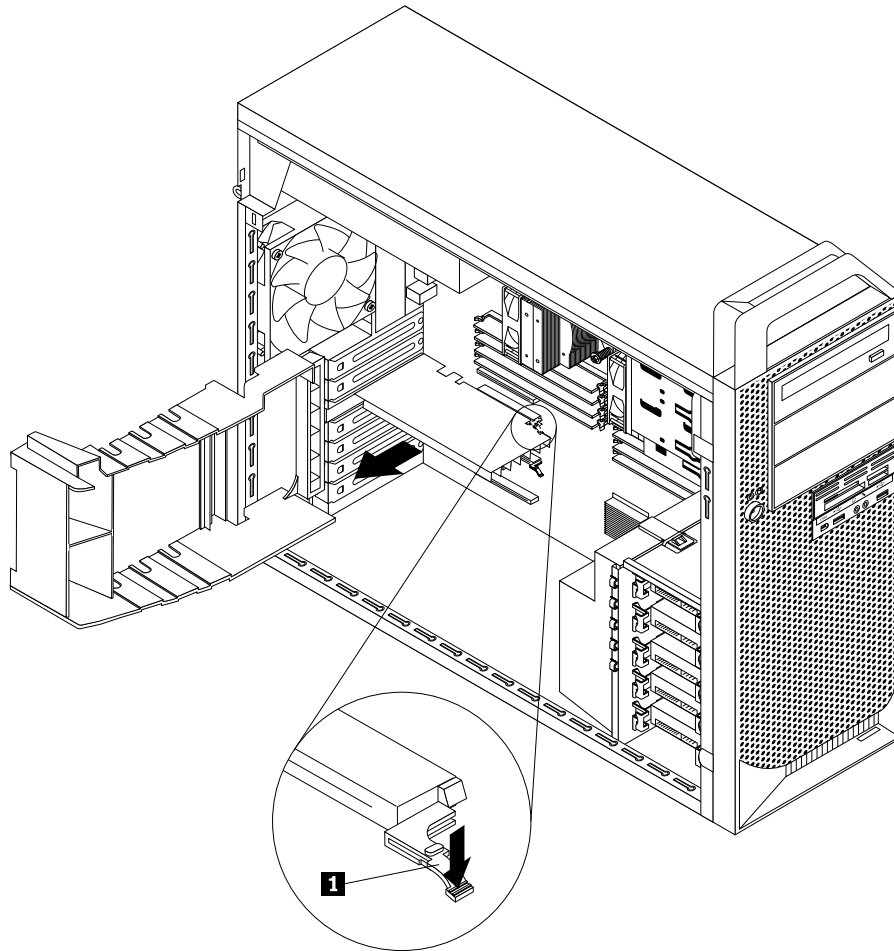

Figure 9. Removing a PCI card

Notes:

- a. The card fits tightly into the card slot. If necessary, alternate moving each side of the card a small amount until it is removed from the card slot.

- b. If the card is held in place by a retaining latch, press the card retaining latch **1** as shown to disengage the latch. Grasp the card and gently pull it out of the card slot.



5. Remove the new PCI card from its static-protective package.
6. Install the new card into the appropriate card slot on the system board. See “Locating parts on the system board” on page 76.
7. Pivot the PCI card latch to the closed position to secure the PCI card.

What to do next:

- To work with another piece of hardware, go to the appropriate section.
- To complete the installation or replacement, go to “Completing the parts replacement” on page 124.

Installing or replacing an mSATA solid-state drive

Attention:

Do not open your computer or attempt any repair before reading and understanding the “Important Safety Information” on page 1.

This section provides instructions on how to install or replace an mSATA solid-state drive.

To install or replace an mSATA solid-state drive, do the following:

1. Turn off the computer and disconnect all power cords from electrical outlets.

2. Remove the computer cover. See “Removing the computer cover” on page 82.
3. Remove the PCI card holder. See “Installing or replacing a PCI card” on page 84.
4. Remove the front fan assembly. See “Replacing the hard disk drive fan assembly” on page 100.
5. Remove any parts or disconnect any cables that might impede your access to the mini PCI express card slot on the system board. See “Locating parts on the system board” on page 76.
6. Depending on whether you are installing or replacing an mSATA solid-state drive, do one of the following:
 - If you are installing an mSATA solid-state drive, go to 7 on page 88.
 - If you are replacing an mSATA solid-state drive, press the two tabs **1** as shown and carefully pivot the mSATA solid-state drive upward at an angle of about 20 degrees. Then, remove the mSATA solid-state drive from the mini PCI express card slot.

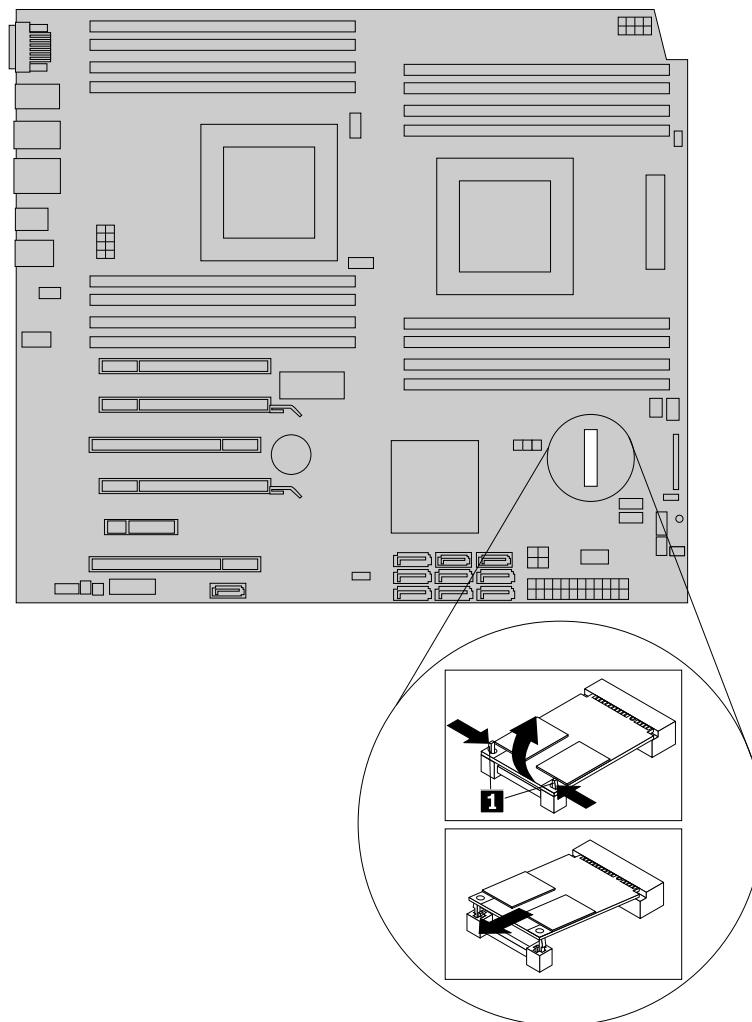

Figure 10. Removing an old mSATA solid-state drive

7. Touch the static-protective package that contains the new mSATA solid-state drive to any unpainted surface on the outside of the computer. Then, take the new mSATA solid-state drive out of the package.
8. Insert the new mSATA solid-state drive into the mini PCI express card slot at an angle of about 20 degrees until it clicks into position. Then, carefully pivot the mSATA solid-state drive downward until it snaps into position and is secured by the two tabs **1**.

Note: Do not touch the contact edge and circuit board of the mSATA solid-state drive.

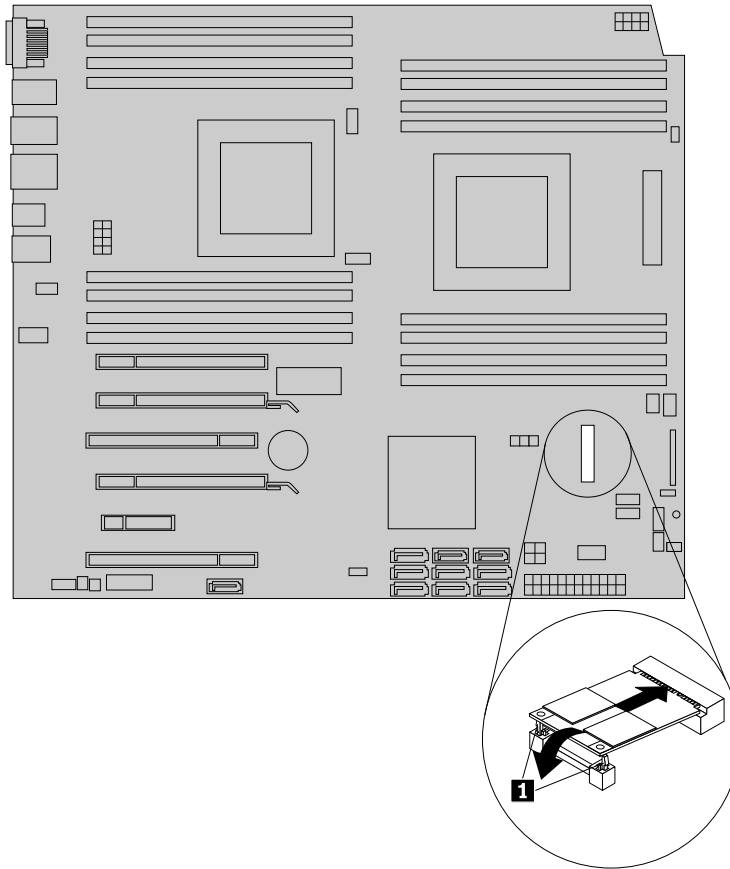

Figure 11. Installing an mSATA solid-state drive

9. Reinstall any parts or reconnect any cables that you have removed.
10. Reinstall the front fan assembly. See “Replacing the hard disk drive fan assembly” on page 100.

What to do next:

- To work with another piece of hardware, go to the appropriate section.
- To complete the installation or replacement, go to “Completing the parts replacement” on page 124.

Installing or replacing a memory module

Attention:
Do not open your computer or attempt any repair before reading and understanding the “Important Safety Information” on page 1.

This section provides instructions on how to install or replace a memory module.

CAUTION:



Turn off the computer and wait three to five minutes to let the computer cool before installing or replacing a memory module.

Your computer has 16 slots for installing or replacing DDR3 ECC UDIMMs or DDR3 ECC RDIMMs. When installing or replacing a memory module, use the following guidelines:

- Use either DDR3 ECC UDIMMs or DDR3 ECC RDIMMs for your computer. Do not install both the UDIMMs and RDIMMs into the same computer.
- Use 2 GB, 4 GB, or 8 GB UDIMMs in any combination up to a maximum of 128 GB.
- Use 2 GB, 4 GB, 8 GB, 16 GB, or 32 GB DDR3 RDIMMs in any combination up to a maximum of 512 GB.
- Always install DIMMs in the numerical order printed on the system board (DIMM1, DIMM2, DIMM3, and so on). Install memory modules into the blue color memory slots first. See “Locating parts on the system board” on page 76.
- If your computer has only one microprocessor installed, be sure to install memory modules only in the memory slots adjacent to that microprocessor.
- If your computer has two microprocessors installed, install equal numbers of memory modules in both sets of microprocessor DIMM slots for maximum performance.

To install or replace a memory module, do the following:

1. Turn off the computer and disconnect all power cords from electrical outlets.
2. Remove the computer cover. See “Removing the computer cover” on page 82.
3. Lay the computer on its side for easier access to the system board.
4. Locate the memory slots. See “Locating parts on the system board” on page 76.
5. Remove any parts that might prevent your access to the memory slots. Depending on your computer model, you might need to remove the PCI Express x16 graphics card for easier access to the memory slots. See “Installing or replacing a PCI card” on page 84.
6. For some computer models, you might need to remove the memory fan duct to get access to the memory slots. To remove the memory fan duct, disconnect the memory fan cable from the system board. See “Locating parts on the system board” on page 76.
7. Pull the fan duct tab outward and pivot the fan duct, and then disengage the rear of the fan duct.

Note: Not all computer models have the memory fan duct.

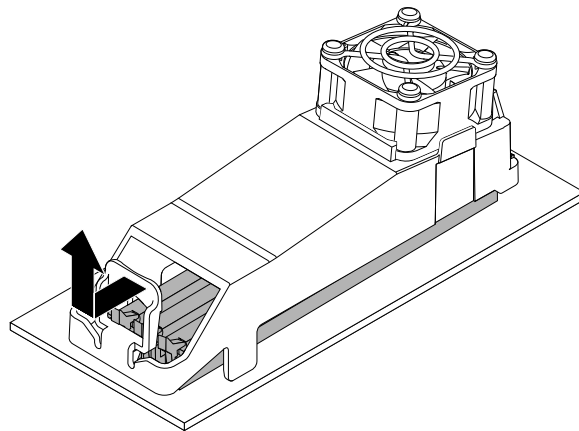

Figure 12. Removing the memory fan duct

8. Depending on whether you are installing or replacing a memory module, do one of the following:

- If you are replacing an old memory module, open the retaining clips and gently pull the memory module out of the memory slot.

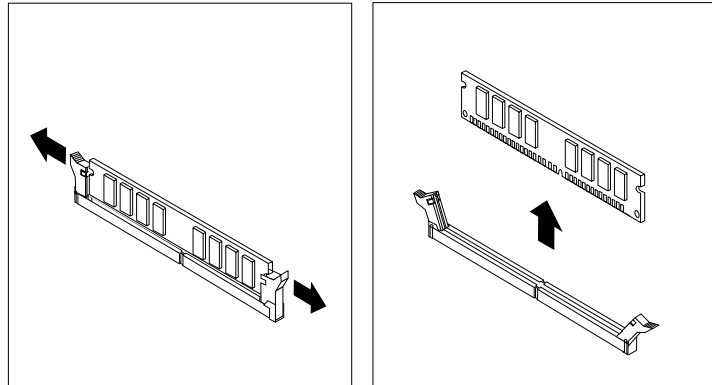

Figure 13. Removing a memory module

- If you are installing a memory module, open the retaining clips of the memory slot into which you want to install the memory module.

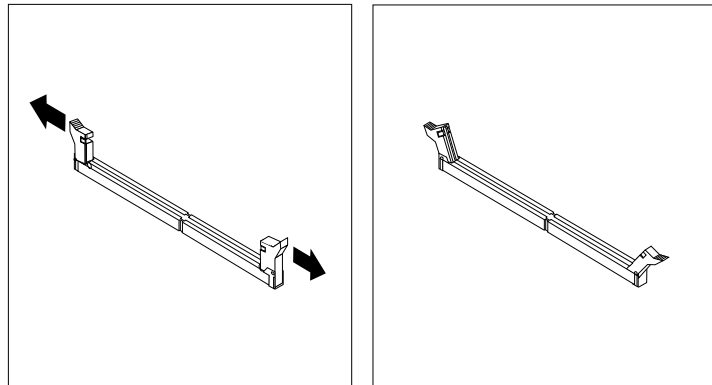

Figure 14. Opening the retaining clips

- Position the new memory module over the memory slot. Make sure that the notch **1** on the memory module aligns correctly with the slot key **2** on the system board. Push the memory module straight down into the slot until the retaining clips close.

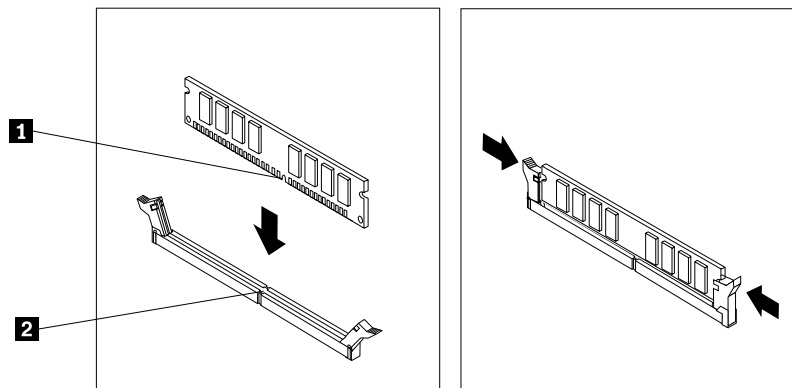

Figure 15. Installing a memory module

- To install the memory fan duct, secure the rear of the fan duct with the retaining clips of the memory slots, and then pivot the fan duct downward until the fan duct snaps into position.

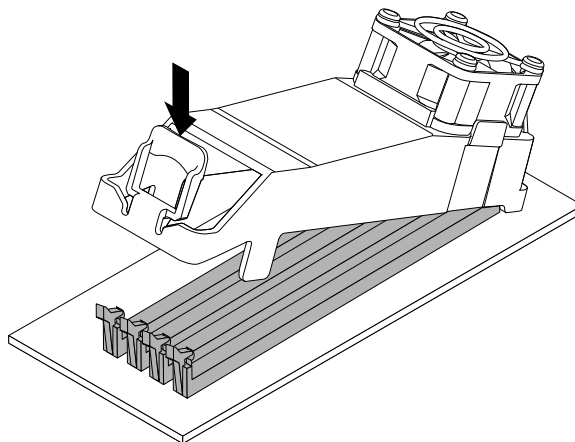

Figure 16. Installing the memory fan duct

- Reconnect the memory fan cable to the system board. See “Locating parts on the system board” on page 76.
- Reinstall the PCI Express x16 graphics card if you have removed it.

What to do next:

- To work with another piece of hardware, go to the appropriate section.
- To complete the installation or replacement, go to “Completing the parts replacement” on page 124.

Installing or replacing the optical drive

Attention:

Do not open your computer or attempt any repair before reading and understanding the “Important Safety Information” on page 1.

This section provides instructions on how to install or replace the optical drive.

To install or replace an optical drive, do the following:

1. Turn off the computer and disconnect all power cords from electrical outlets.
2. Remove the computer cover. See “Removing the computer cover” on page 82.
3. Remove the front bezel. See “Removing and reinstalling the front bezel” on page 83.
4. Locate the optical drive. See “Locating major FRUs and CRUs” on page 74.
5. Depending on whether you are installing or replacing an optical drive, do one of the following:
 - If you are installing a secondary optical drive, remove the plastic panel in the front bezel for the drive bay you want to use. If there is a metal static shield installed in the drive bay, remove the metal static shield.
 - If you are replacing an optical drive, disconnect the signal cable and the power cable from the rear of the optical drive, press the drive latch **1**, and then slide the optical drive out of the front of the computer.

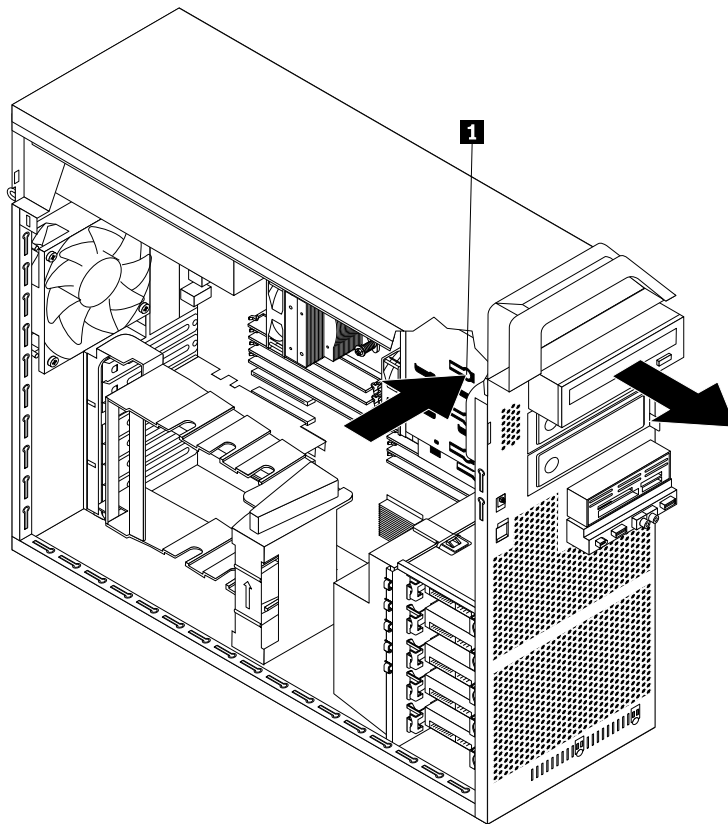

Figure 17. Removing the optical drive

6. Install the optical drive retainer on the side of the new optical drive.

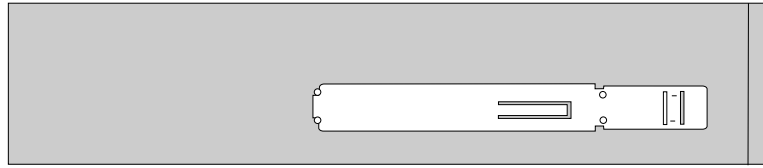

Figure 18. Installing the optical drive retainer

7. Slide the new optical drive into the drive bay from the front of the computer until the optical drive snaps into position.

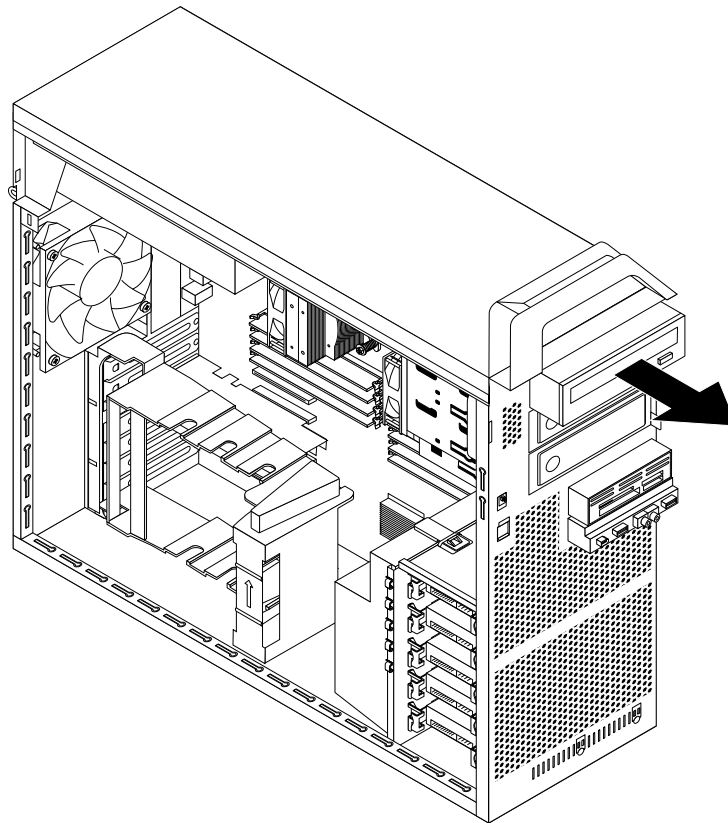

Figure 19. Installing the optical drive

8. Connect the signal cable and the power cable to the new optical drive.

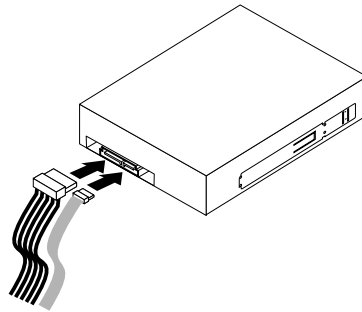

Figure 20. Connecting the optical drive

9. Reinstall the front bezel. See “Removing and reinstalling the front bezel” on page 83.

What to do next:

- To work with another piece of hardware, go to the appropriate section.
- To complete the installation or replacement, go to “Completing the parts replacement” on page 124.

Replacing the card reader

Attention:

Do not open your computer or attempt any repair before reading and understanding the “Important Safety Information” on page 1.

This section provides instructions on how to install or replace the card reader.

To replace the card reader, do the following:

1. Remove all media from the drives and turn off all attached devices and the computer. Then, disconnect all power cords from electrical outlets and disconnect all cables that are connected to the computer.
2. Remove the computer cover. See “Removing the computer cover” on page 82.
3. Remove the front bezel. See “Removing and reinstalling the front bezel” on page 83.
4. Locate the card reader. See “Locating major FRUs and CRUs” on page 74.
5. Disconnect the card reader cable from the system board. See “Locating parts on the system board” on page 76.

6. Press the blue retaining clip **1** to remove the card reader out of the chassis.

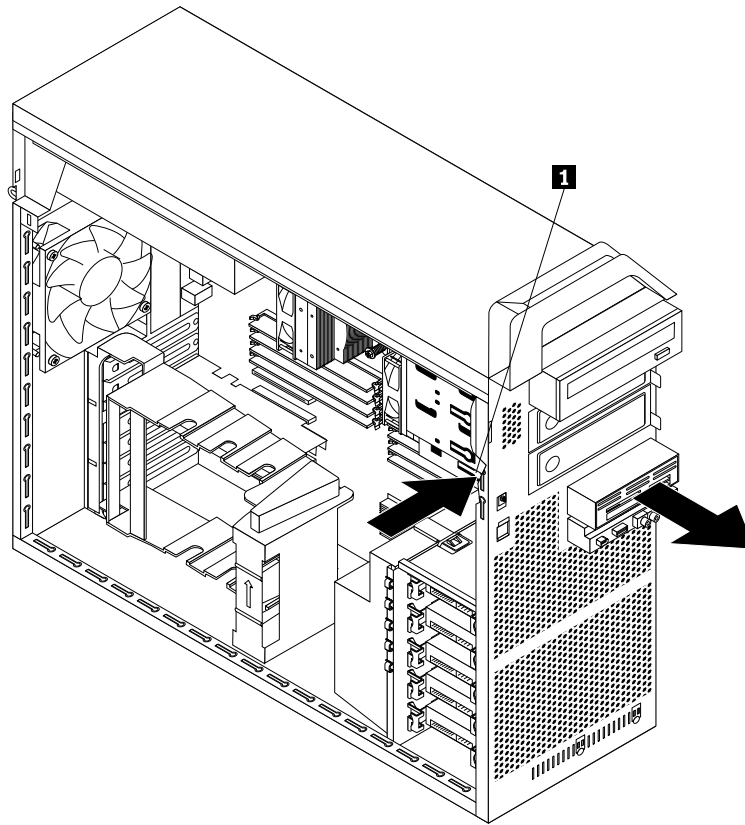

Figure 21. Removing the card reader

7. Install the card reader retainer on the side of the new card reader.

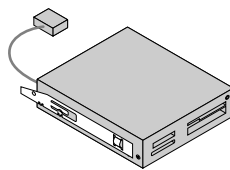

Figure 22. Installing the card reader retainer

- Slide the card reader with retainer into the card reader drive bay until it snaps into position.

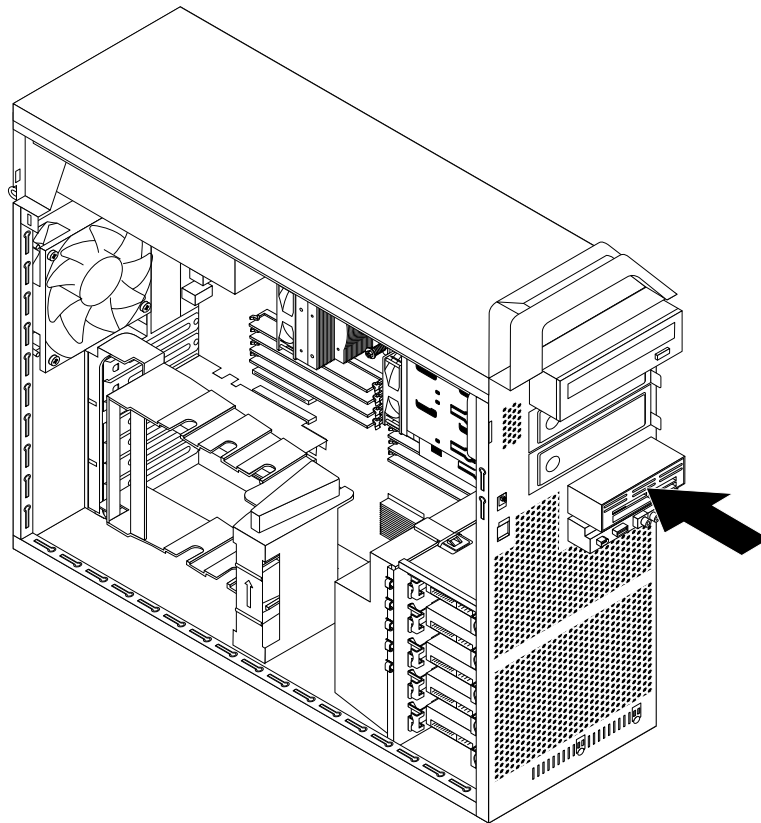

Figure 23. Installing the card reader

- Reconnect the card reader cable to the system board. See “Locating parts on the system board” on page 76.
- Reinstall the front bezel. See “Removing and reinstalling the front bezel” on page 83.

What to do next:

- To work with another piece of hardware, go to the appropriate section.
- To complete the installation or replacement, go to “Completing the parts replacement” on page 124.

Replacing the battery

Attention:

Do not open your computer or attempt any repair before reading and understanding the “Important Safety Information” on page 1.

Your computer has a special type of memory that maintains the date, time, and settings for built-in features, such as parallel-port assignments (configuration). A battery keeps this information active when you turn off the computer.

The battery normally requires no charging or maintenance throughout its life; however, no battery lasts forever. If the battery fails, the date, time, and configuration information (including passwords) are lost. An error message is displayed when you turn on the computer.

Refer to the “Lithium battery notice” in the *ThinkStation Safety, Warranty, and Setup Guide* for information about replacing and disposing of the battery.

To replace the battery, do the following:

1. Turn off the computer and disconnect all power cords from electrical outlets.
2. Remove the computer cover. See “Removing the computer cover” on page 82.
3. Locate the battery. See “Locating parts on the system board” on page 76.
4. Remove the old battery.

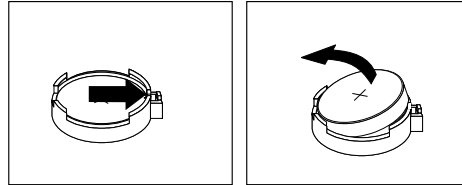

Figure 24. Removing the old battery

5. Install a new battery.

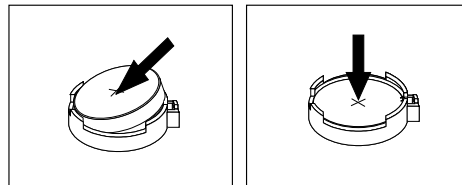

Figure 25. Installing a new battery

6. Reinstall the computer cover and connect the cables. See “Completing the parts replacement” on page 124.

Note: When the computer is turned on for the first time after replacing the battery, an error message might be displayed. This is normal after replacing the battery.

7. Turn on the computer and all attached devices.
8. Use the Setup Utility program to set the date, time, and any passwords. See Chapter 6 “Using the Setup Utility program” on page 55.

What to do next:

- To work with another piece of hardware, go to the appropriate section.
- To complete the installation or replacement, go to “Completing the parts replacement” on page 124.

Replacing the heat sink and fan assembly

Attention:

Do not open your computer or attempt any repair before reading and understanding the “Important Safety Information” on page 1.

This section provides instructions on how to replace the heat sink and fan assembly.

CAUTION:



The heat sink and fan assembly might be very hot. Before you open the computer cover, turn off the computer and wait several minutes until the computer is cool.

To replace the heat sink and fan assembly, do the following:

1. Turn off the computer and disconnect all power cords from electrical outlets.
2. Remove the computer cover. See “Removing the computer cover” on page 82.
3. Lay the computer on its side for easier access to the system board.
4. Locate the heat sink and fan assembly you want to replace. Your computer have two heat sink and fan assemblies. See “Locating parts on the system board” on page 76.
5. Disconnect the heat sink and fan assembly cable from the microprocessor fan connector on the system board. See “Locating parts on the system board” on page 76.
6. Follow this sequence to remove the four screws that secure each heat sink and fan assembly to the system board:
 - a. Partially remove screw **1**, then fully remove screw **2**, and then fully remove screw **1**.
 - b. Partially remove screw **3**, then fully remove screw **4**, and then fully remove screw **3**.

Note: Carefully remove the four screws from the system board to avoid any possible damage to the system board. The four screws cannot be removed from the heat sink and fan assembly.

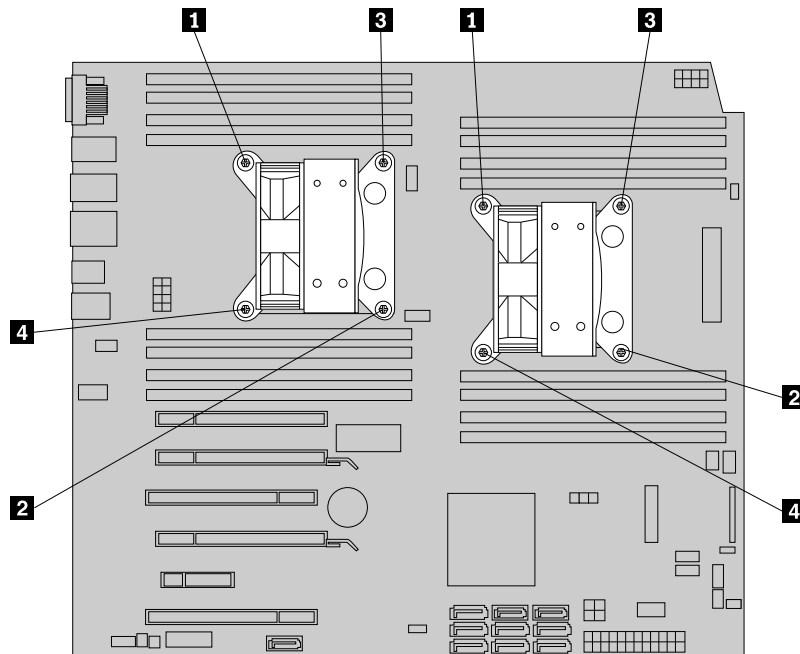

Figure 26. Removing the heat sink and fan assembly

7. Lift the failing heat sink and fan assembly off the system board.

Notes:

- a. You might have to gently twist the heat sink and fan assembly to free it from the microprocessor.
 - b. Do not touch the thermal grease while handling the heat sink and fan assembly.
8. Position the two new heat sink and fan assemblies in a way that the fans are toward the rear of the computer. Align the four screws on each heat sink and fan assembly with the holes on the system board.

9. Follow the following sequence to install the four screws to secure each new heat sink and fan assembly. Do not over-tighten the screws.
 - a. Partially tighten screw **1**, then fully tighten screw **2**, and then fully tighten screw **1**.
 - b. Partially tighten screw **3**, then fully tighten screw **4**, and then fully tighten screw **3**.
10. Connect the heat sink and fan assembly cables to the microprocessor fan connectors on the system board. See “Locating parts on the system board” on page 76.

What to do next:

- To work with another piece of hardware, go to the appropriate section.
- To complete the installation or replacement, go to “Completing the parts replacement” on page 124.

Replacing the hard disk drive fan assembly

Attention:

Do not open your computer or attempt any repair before reading and understanding the “Important Safety Information” on page 1.

This section provides instructions on how to replace the hard disk drive fan assembly.

To replace the hard disk drive fan assembly, do the following:

1. Turn off the computer and disconnect all power cords from electrical outlets.
2. Remove the computer cover. See “Removing the computer cover” on page 82.
3. Disconnect the hard disk drive fan assembly cable from the system board. See “Locating parts on the system board” on page 76.
4. Remove any parts that might prevent your access to the hard disk drive fan assembly. Depending on your computer model, you might need to remove the PCI Express x16 graphics card for easier access to the hard disk drive fan assembly. See “Installing or replacing a PCI card” on page 84.

5. Press the tab, and then pivot the hard disk drive fan outward to remove it from the chassis.

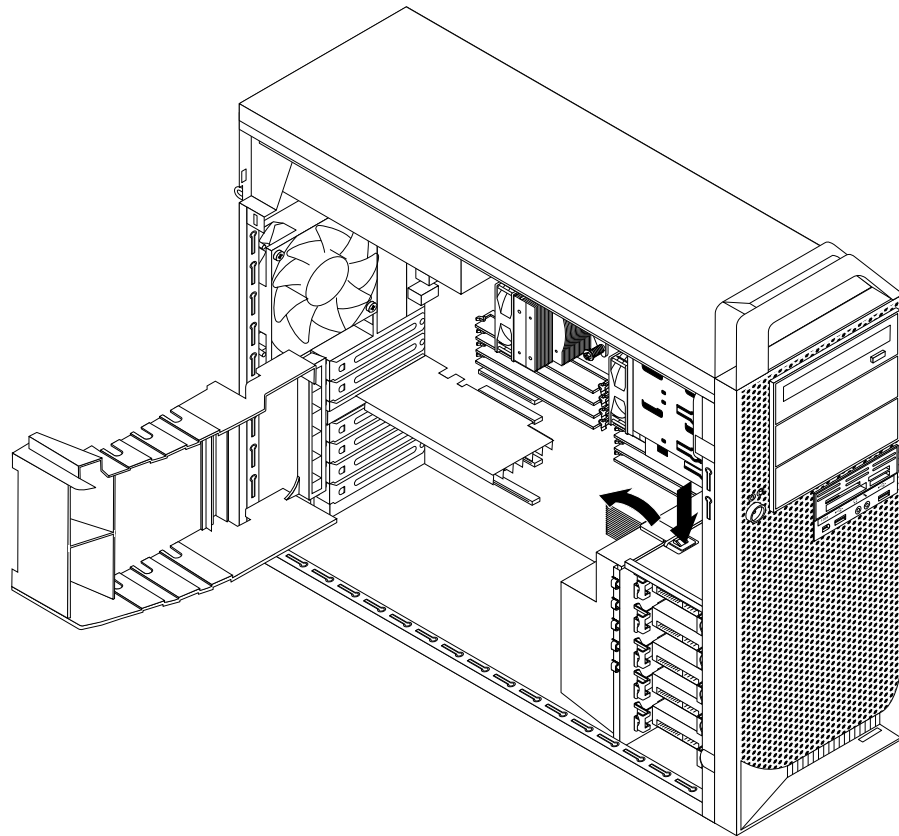

Figure 27. Removing the hard disk drive fan assembly

6. Position the hard disk drive fan, and then pivot the fan to insert the tab into the chassis.
7. Reconnect the hard disk drive fan cable to the system board.

What to do next:

- To work with another piece of hardware, go to the appropriate section.
- To complete the installation or replacement, go to “Completing the parts replacement” on page 124.

Replacing the rear fan assembly

Attention:

Do not open your computer or attempt any repair before reading and understanding the “Important Safety Information” on page 1.

This section provides instructions on how to replace the rear fan assembly.

To replace the rear fan assembly, do the following:

1. Turn off the computer and disconnect all power cords from electrical outlets.
2. Remove the computer cover. See “Removing the computer cover” on page 82.
3. Locate the rear fan assembly. See “Locating major FRUs and CRUs” on page 74.
4. Disconnect the rear fan assembly cable from the system fan connector on the system board. See “Locating parts on the system board” on page 76.

5. The rear fan assembly is attached to the chassis by four rubber mounts. Remove the rear fan assembly by breaking or cutting the rubber mounts and gently pulling the rear fan assembly out of the chassis.

Note: The new rear fan assembly will have four new rubber mounts attached.

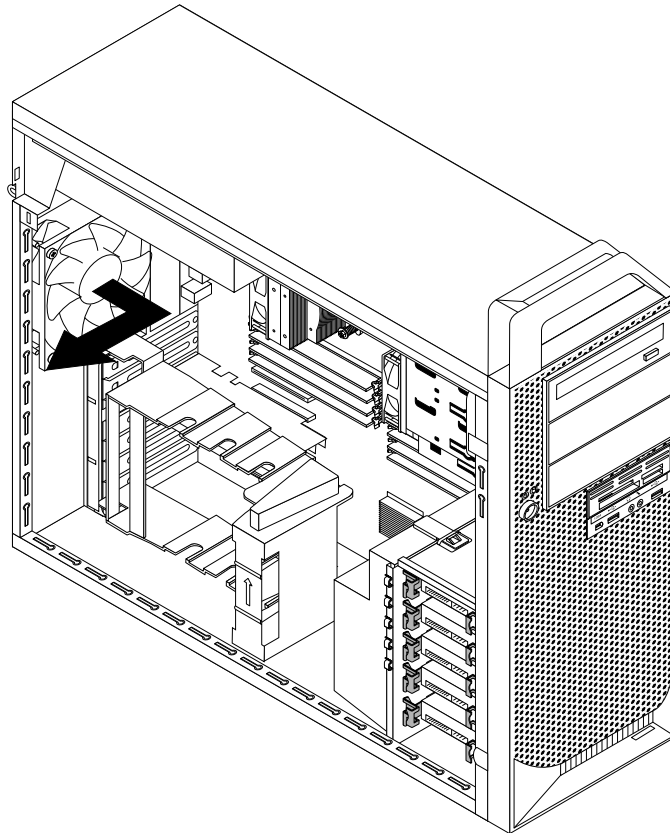

Figure 28. Removing the rear fan assembly

6. Install the new rear fan assembly by aligning the new rubber mounts with the corresponding holes in the chassis and push the rubber mounts through the holes. Pull on the tips of the rubber mounts until the rear fan assembly is secured in place.

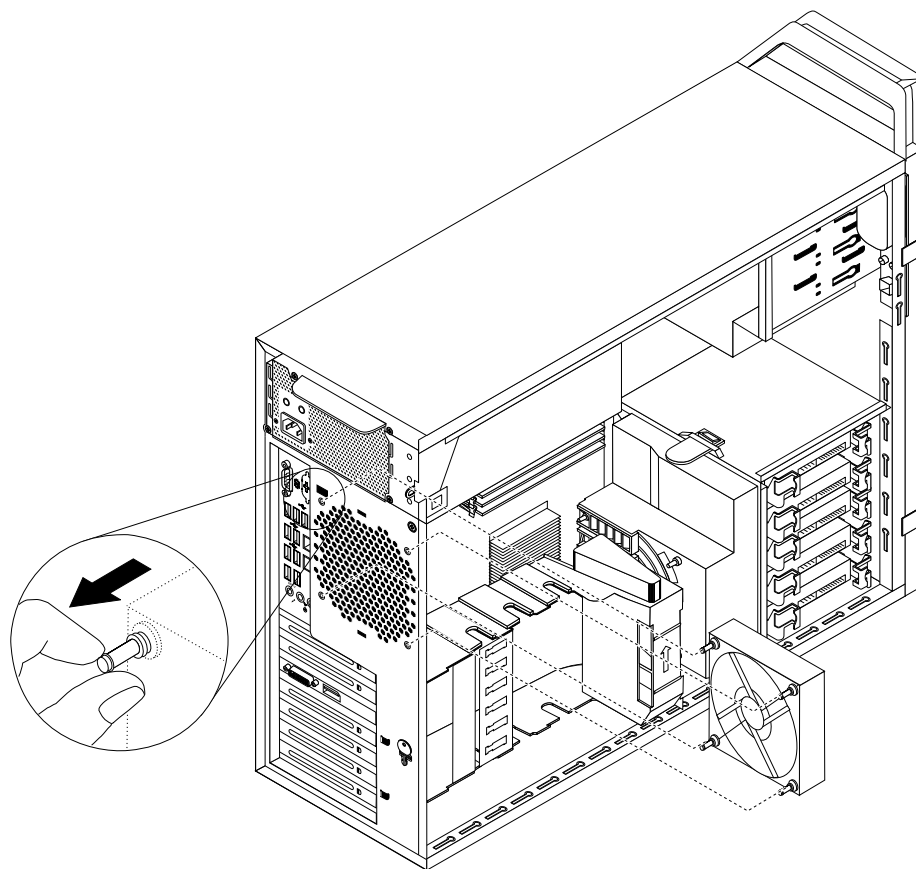

Figure 29. Installing the rear fan assembly

7. Connect the rear fan assembly cable to the system fan connector on the system board.

What to do next:

- To work with another piece of hardware, go to the appropriate section.
- To complete the installation or replacement, go to “Completing the parts replacement” on page 124.

Installing or replacing a hard disk drive

Attention:
Do not open your computer or attempt any repair before reading and understanding the “Important Safety Information” on page 1.

This section provides instructions on how to install or replace a hard disk drive.

Notes: If you are installing additional hard disk drives, ensure that your computer is properly configured to support them.

- If installing five SATA hard disk drives, ensure that the SATA hard disk drive enablement module (one to five hard disk drives) is installed.
- If installing SAS hard disk drives, ensure that the SAS hard disk drive enablement module or the LSI MegaRAID SAS adapter is installed.

To install or replace a hard disk drive, do the following:

1. Turn off the computer and disconnect all power cords from electrical outlets.
2. Remove the computer cover. See “Removing the computer cover” on page 82.
3. Locate the hard disk drive. See “Locating internal drives” on page 79.
4. Disconnect the signal cable and the power cable from the hard disk drive.
5. Pull the bracket handle out to remove the hard disk drive from the chassis.

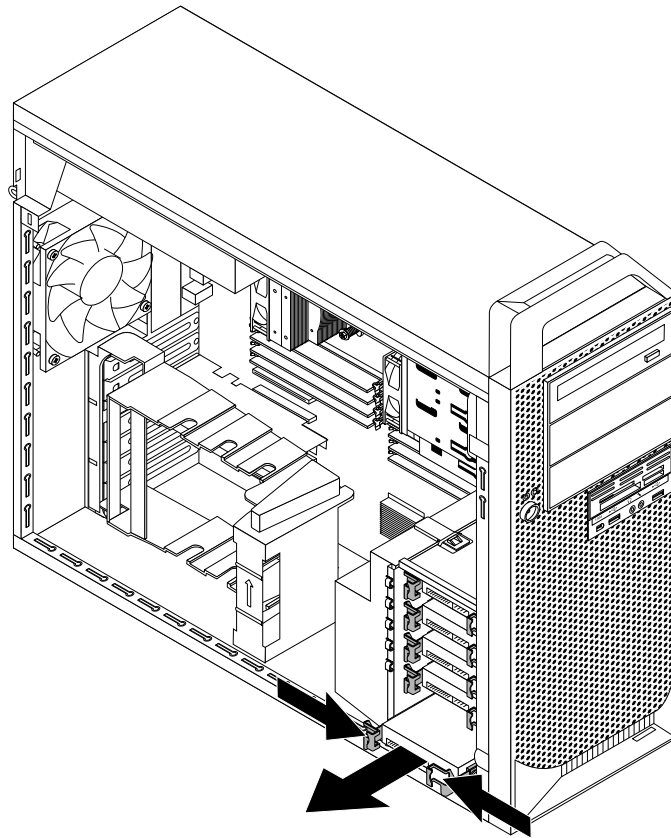

Figure 30. Removing the hard disk drive

6. Flex the sides of the bracket to remove the hard disk drive from the bracket.

7. To install a new hard disk drive into the bracket, flex the bracket and align pin **1**, pin **2**, pin **3**, and pin **4** on the bracket with the corresponding holes in the hard disk drive. Do not touch the circuit board **5** on the bottom of the hard disk drive.

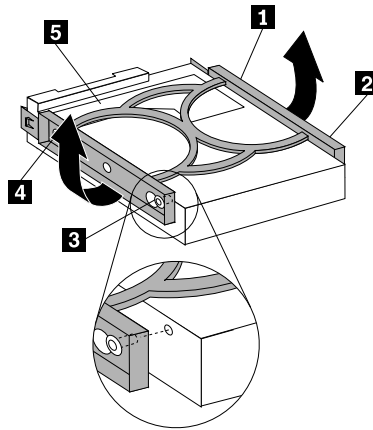

Figure 31. Installing the hard disk drive into the bracket

Note: If you are replacing or installing a 2.5-inch hard disk drive, you need to install it into a 2.5 to 3.5-inch converter bracket. Then install the 2.5-inch hard disk drive with the converter bracket into the 3.5-inch hard disk drive bracket.

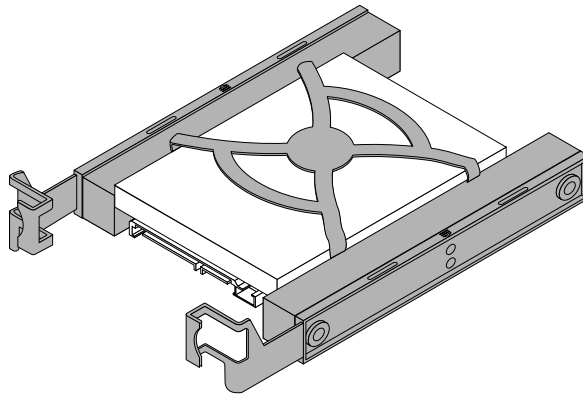

Figure 32. Installing 2.5-inch to 3.5-inch converter bracket before installing the outer bracket

8. Slide the new hard disk drive into the drive cage until it snaps into position.

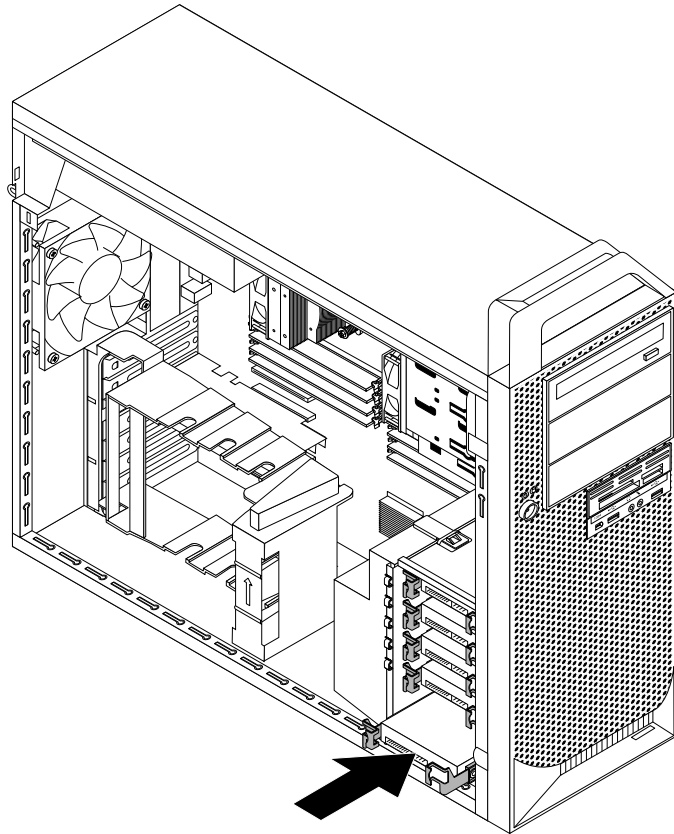

Figure 33. Installing the hard disk drive

9. Connect the signal cable and the power cable to the new hard disk drive.

Note: If you are installing SAS hard disk drives, you must connect the signal cables and power cables to the SAS-to-SATA conversion adapter before you connect them to the hard disk drive.

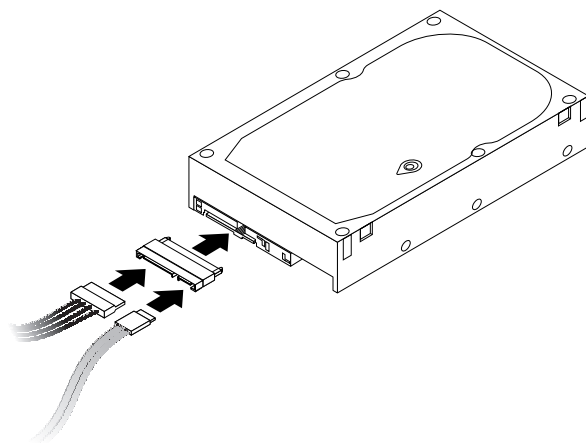

Figure 34. Connecting SAS cables to SAS-to-SATA conversion adapter

What to do next:

- To work with another piece of hardware, go to the appropriate section.
- To complete the installation or replacement, go to “Completing the parts replacement” on page 124.

Installing or replacing a hard disk drive enablement module

Attention:

Do not open your computer or attempt any repair before reading and understanding the “Important Safety Information” on page 1.

This section provides instructions on how to install or replace a hard disk drive enablement module.

To install or replace a hard disk drive enablement module, do the following:

1. Turn off the computer and disconnect all power cords from electrical outlets.
2. Remove the computer cover. See “Removing the computer cover” on page 82.
3. Lift to open the PCI card retainer. See Figure 8 “Opening the PCI card retainer” on page 85.
4. Remove the hard disk drive fan assembly. See “Replacing the hard disk drive fan assembly” on page 100.
5. Locate the hard disk drive enablement module. See “Locating parts on the system board” on page 76.
6. If you are replacing the hard disk drive enablement module, press the plastic tabs together and then lift the hard disk drive enablement module upward to remove it from the system board.

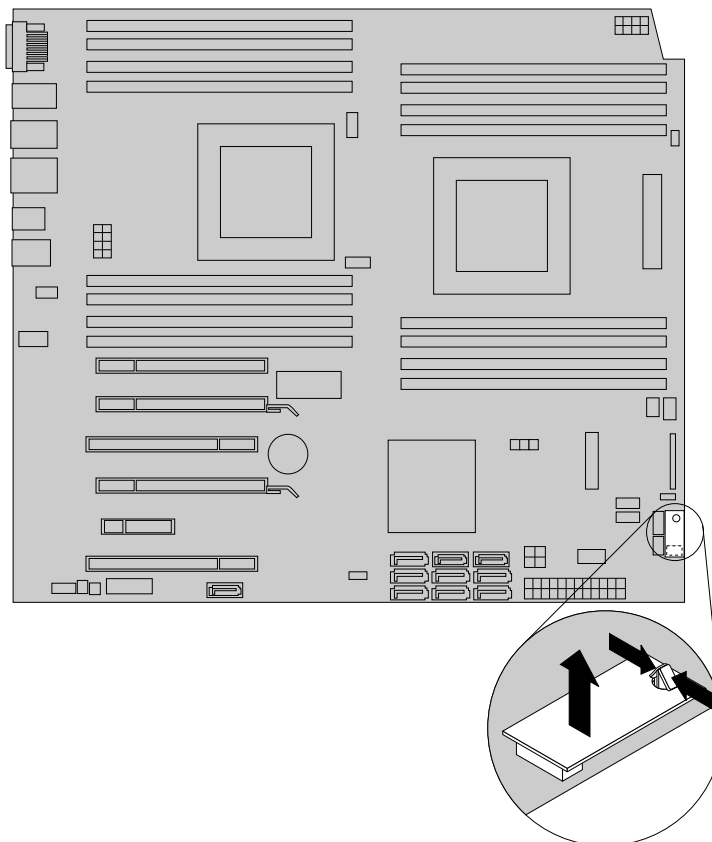

Figure 35. Removing the hard disk drive enablement module

7. To install a new hard disk drive enablement module, align the hole in the hard disk drive enablement module with the plastic standoff on the system board, and then position the hard disk drive module over the corresponding connector on the system board.

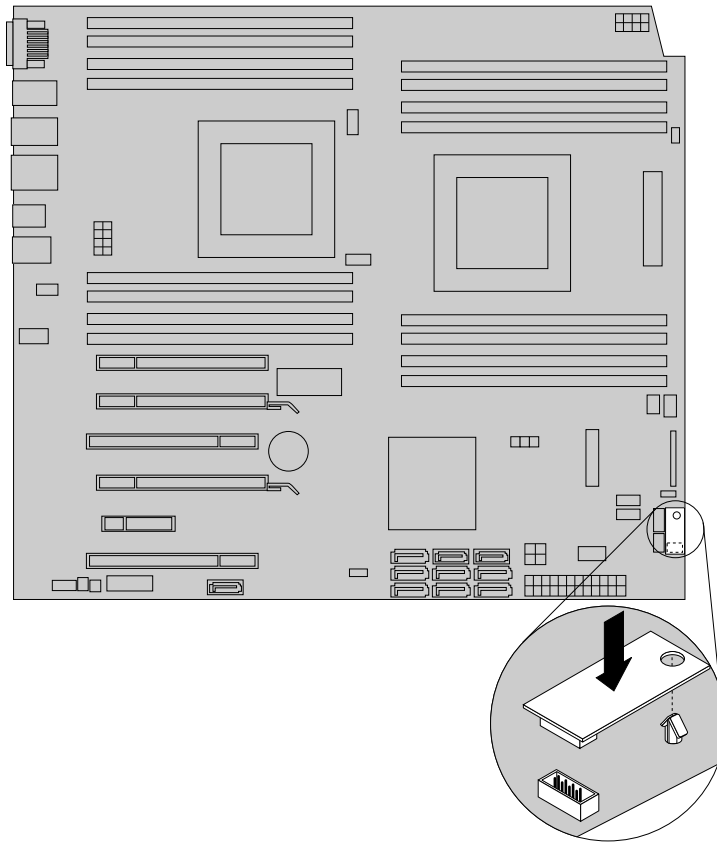

Figure 36. Installing a new hard disk drive enablement module

8. Reinstall the hard disk drive fan assembly and close the PCI card retainer. See “Replacing the hard disk drive fan assembly” on page 100.

What to do next:

- To work with another piece of hardware, go to the appropriate section.
- To complete the installation or replacement, go to “Completing the parts replacement” on page 124.

Replacing the front audio and USB assembly

Attention:
Do not open your computer or attempt any repair before reading and understanding the “Important Safety Information” on page 1.

This section provides instructions on how to replace the front audio and USB assembly.

To replace the front audio and USB assembly, do the following:

1. Turn off the computer and disconnect all power cords from electrical outlets.
2. Remove the computer cover. See “Removing the computer cover” on page 82.
3. Remove the front bezel. See “Removing and reinstalling the front bezel” on page 83.

4. Locate the front audio and USB assembly. See “Locating major FRUs and CRUs” on page 74.
5. Disconnect the front audio and USB assembly cables from the system board. See “Locating parts on the system board” on page 76.

Note: Make sure you note the locations of the cables when you disconnect the cables from the system board.

6. Remove the two screws that secure the front audio and USB assembly bracket, and then remove the bracket from the chassis.

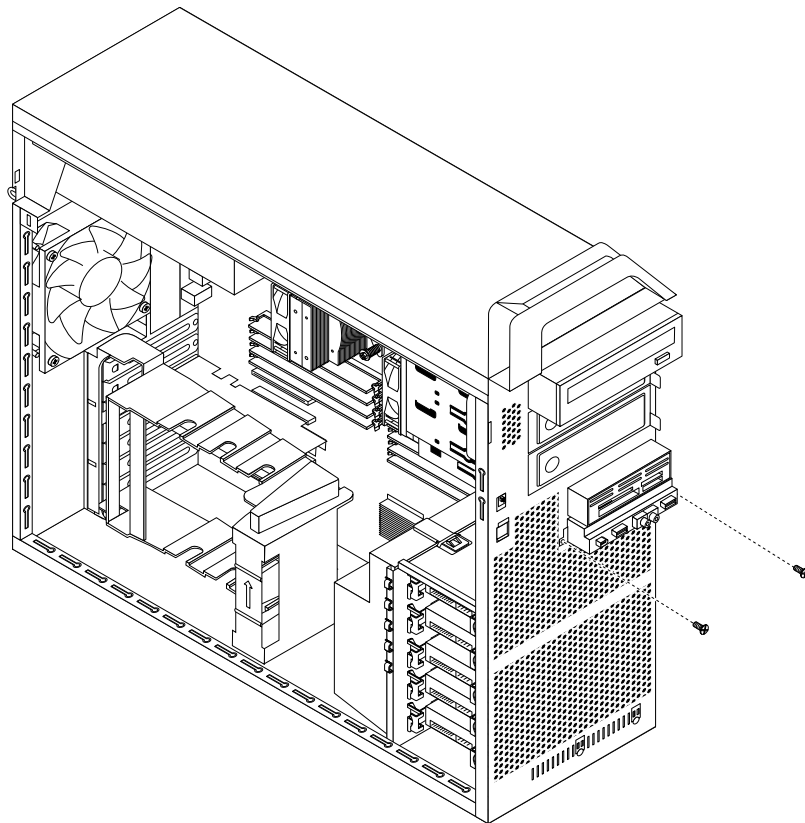

Figure 37. Removing the two screws that secure the front audio and USB assembly to the chassis

7. Position the front audio and USB assembly bracket into the chassis, and then align the two screw holes in the bracket with the corresponding holes in the chassis. Install the two screws to secure the front audio and USB bracket to the chassis.
8. Reconnect the front audio and USB assembly cables to the front audio connector and the front USB connector on the system board. See “Locating parts on the system board” on page 76.

What to do next:

- To work with another piece of hardware, go to the appropriate section.
- To complete the installation or replacement, go to “Completing the parts replacement” on page 124.

Replacing the internal speaker

Attention:

Do not open your computer or attempt any repair before reading and understanding the “Important Safety Information” on page 1.

This section provides instructions on how to replace the internal speaker.

Note: The internal speaker is only available on some models.

To replace the internal speaker, do the following:

1. Turn off the computer and disconnect all power cords from electrical outlets.
2. Remove the computer cover. See “Removing the computer cover” on page 82.
3. Locate the internal speaker connector and disconnect the internal speaker cable from the system board. See “Locating parts on the system board” on page 76.
4. Press the tab **3** inward and slide the internal speaker **1** upward to completely remove it from the chassis.

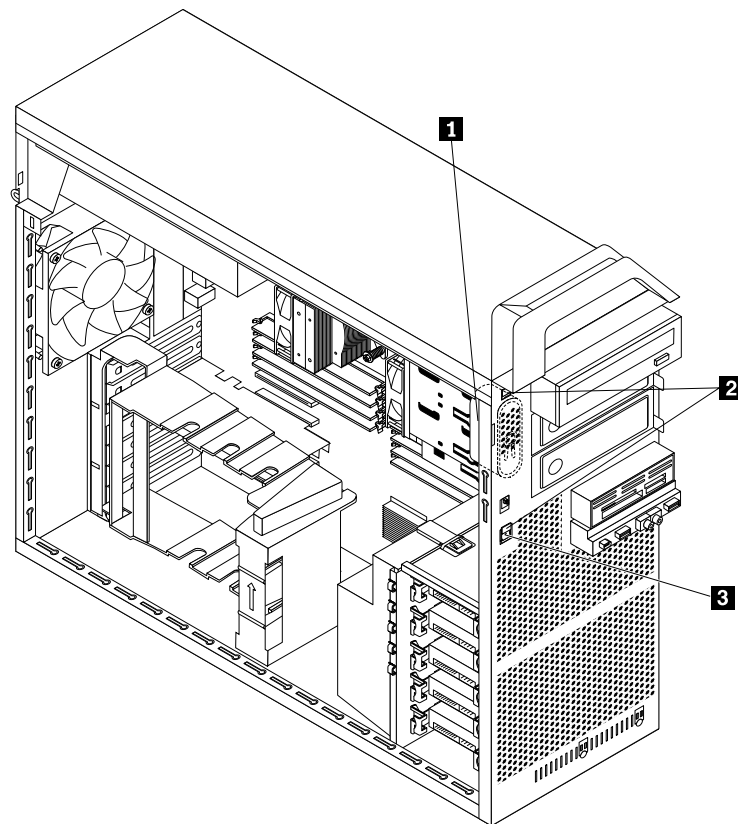

Figure 38. Removing the internal speaker

5. Position the new internal speaker to insert the two tabs **2** into the corresponding holes in the chassis, and then push downward the internal speaker until it is secured in place.
6. Connect the internal speaker cable to the system board. See “Locating parts on the system board” on page 76.

What to do next:

- To work with another piece of hardware, go to the appropriate section.
- To complete the installation or replacement, go to “Completing the parts replacement” on page 124.

Installing or replacing the microprocessor

This topic provides instructions on how to install or replace the microprocessor.

Installing the second microprocessor

Attention:

Do not open your computer or attempt any repair before reading and understanding the “Important Safety Information” on page 1.

This topic provides instructions on how to install the second microprocessor.

Depending on the model, your computer might come with one or two microprocessors. For computer models with one microprocessor, the microprocessor is installed in the microprocessor socket 1 and the microprocessor socket 2 is protected by a plastic socket cover. You can purchase a microprocessor option kit from Lenovo and install the second microprocessor to expand system capabilities.

CAUTION:

The heat sink and microprocessor might be very hot. Before you open the computer cover, turn off the computer and wait several minutes until the computer is cool.



Notes:

- Ensure that you install the correct type of microprocessor option your computer supports. When two microprocessors are installed, both must be identical.
- For E5-1600 series microprocessors, the computer can support only one installed. If you want to install two microprocessors into your computer, use the E5-2600 series microprocessors.
- A second heat sink and fan assembly is also required. Ensure that you have this assembly available before starting the installation.
- Use any documentation that comes with the microprocessor option kit and follow those instructions in addition to the instructions in this topic.
- Your microprocessor, socket, and socket cover might look slightly different from the illustrations in this topic.

To install the second microprocessor, do the following:

1. Remove all media from the drives and turn off all attached devices and the computer. Then, disconnect all power cords from electrical outlets and disconnect all cables that are connected to the computer.
2. Remove the computer cover. See “Removing the computer cover” on page 82.
3. Place the computer on its side to gain easier access to the system board.
4. Locate the microprocessor socket 2 on the system board. See “Locating parts on the system board” on page 76.

- Open the small handle **2** by gently pressing down the small handle, and then pulling the small handle a little bit outward to release it from the secured position. Then, open the other small handle **1** by following the same instructions. Ensure that the small handles are in the fully open position.

Note: There are two marks on the microprocessor retainer. You need to open the small handle marked with  ① → first, and then you can open the other small handle marked with ←  ①.

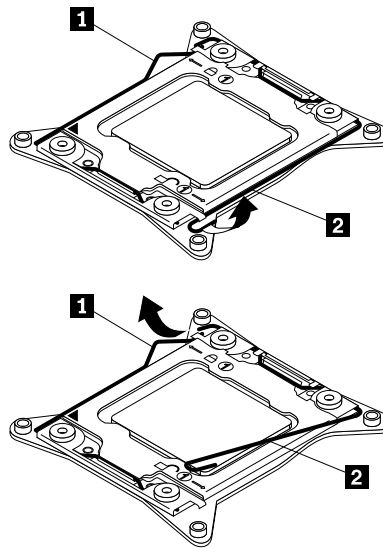

Figure 39. Opening the handles

- Gently press down the small handle **2** to open the microprocessor retainer. Pivot the retainer upward until it is in the fully open position.

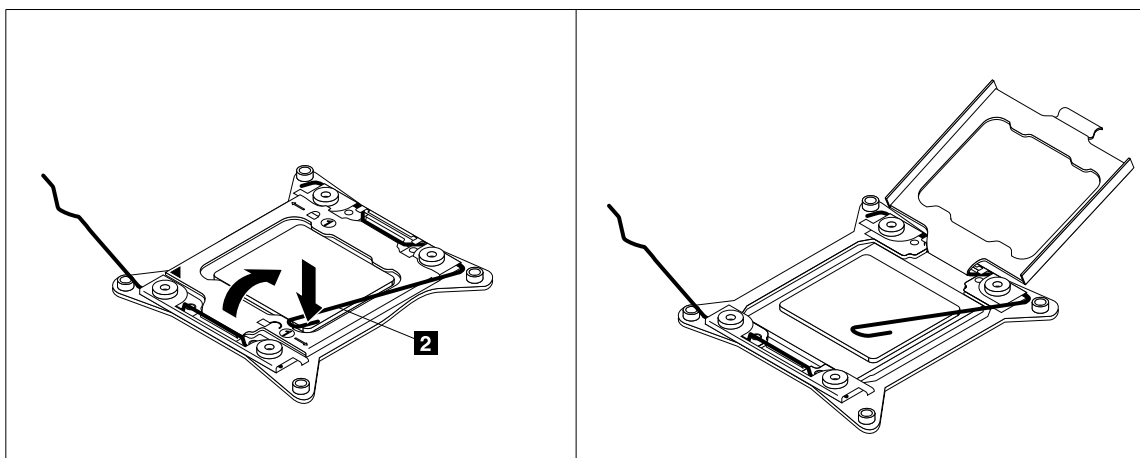

Figure 40. Opening the microprocessor retainer

- Touch only the edges of the microprocessor and carefully lift it straight up and out of the microprocessor socket. Place the old microprocessor on a static-protective surface.

Notes:

- Do not touch the gold contacts on the bottom of the microprocessor.

- Do not drop anything onto the microprocessor socket while it is exposed. The socket pins must be kept as clean as possible.

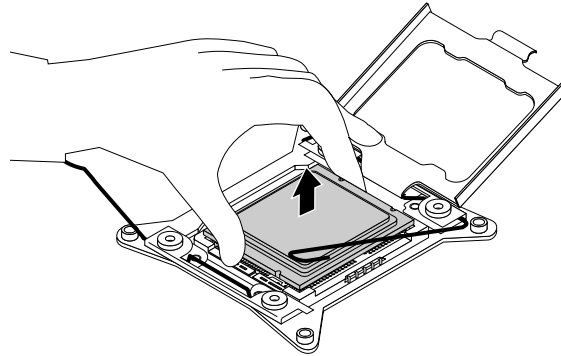

Figure 41. Removing the microprocessor

8. Touch the static-protective package that contains the new microprocessor to any unpainted surface on the outside of the computer. Then, remove the new microprocessor from the package.
9. Remove the new microprocessor from the protective cover that protects the gold contacts on the bottom of the new microprocessor. Do not touch the pins on the microprocessor socket or the gold contacts on the bottom of the new microprocessor.

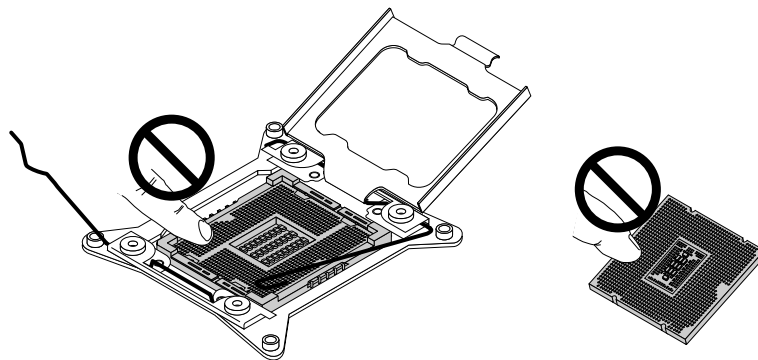

Figure 42. Do not touch the pins

10. Note the orientation of the new microprocessor. Hold the new microprocessor by its edges and align the notches **1** on it with the tabs **2** in the microprocessor socket. Then, carefully lower the new microprocessor straight down into the microprocessor socket.

Note: The small triangle **3** on one corner of the new microprocessor is the microprocessor orientation indicator. The new microprocessor is in the correct orientation when this indicator faces the beveled corner **4** of the microprocessor socket.

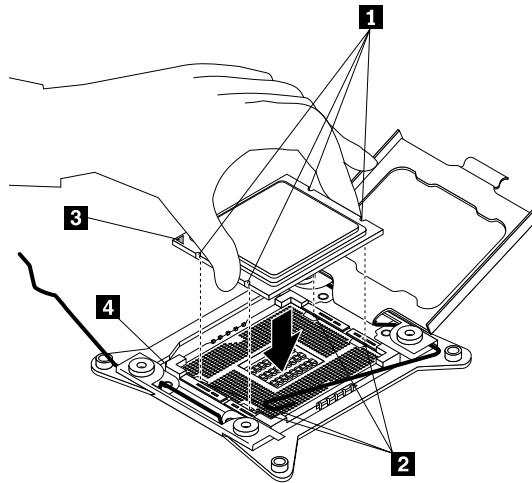

Figure 43. Installing the microprocessor

11. Pivot the microprocessor retainer downward to close the retainer.

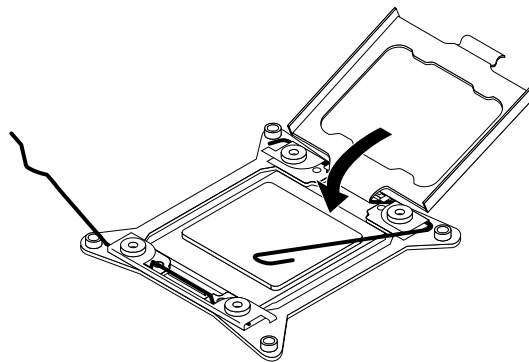





Figure 44. Closing the microprocessor retainer

12. Gently press down the small handle **1**, and then push the handle inward to secure it. Then gently press down the small handle **2** and push the handle inward to lock the microprocessor retainer into position and secure the new microprocessor in the socket.

Note: There are two marks on the microprocessor retainer. Ensure that you close the small handle marked with   ① first, and then close the small handle marked with   ①. Always follow the correct sequence when you close the small handles.

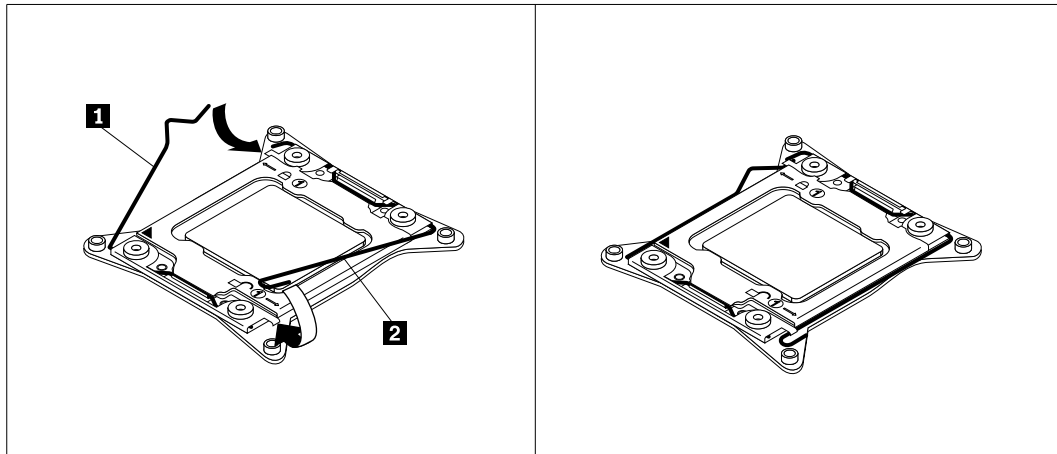

Figure 45. Securing the microprocessor in the socket

13. Install the heat sink and fan assembly. See “Replacing the heat sink and fan assembly” on page 98.

What to do next:

- To work with another piece of hardware, go to the appropriate section.
- To complete the replacement, go to “Completing the parts replacement” on page 124.

Replacing a microprocessor

Attention:

Do not open your computer or attempt any repair before reading and understanding the “Important Safety Information” on page 1.

This section provides instructions on how to replace a microprocessor.

Depending on the model, your computer might come with one or two microprocessors. For computer models with one microprocessor, the microprocessor is installed in the microprocessor socket 1 and the microprocessor socket 2 is protected by a plastic socket cover. You can purchase a microprocessor option kit from Lenovo and install the second microprocessor to expand computer capabilities.

CAUTION:



The heat sink and microprocessor might be very hot. Before you open the computer cover, turn off the computer and wait several minutes until the computer is cool.

Notes:

- Ensure that you install the correct type of microprocessor option your computer supports. When two microprocessors are installed, both must be identical.

- For E5-1600 series microprocessors, the computer can support only one installed. If you want to install two microprocessors into your computer, use the E5-2600 series microprocessors.
- Use any documentation that comes with the microprocessor option kit and follow those instructions in addition to the instructions in this topic.
- Your microprocessor, socket, and socket cover might look slightly different from the illustrations in this topic.

To replace a microprocessor, do the following:

1. Remove all media from the drives and turn off all attached devices and the computer. Then, disconnect all power cords from electrical outlets and disconnect all cables that are connected to the computer.
2. Remove the computer cover. See “Removing the computer cover” on page 82.
3. Place the computer on its side to gain easier access to the system board.
4. Remove the heat sink and fan assembly. See “Replacing the heat sink and fan assembly” on page 98.
5. Locate the correct microprocessor socket on the system board . See “Replacing the system board” on page 119.
6. Open the small handle **2** by gently pressing down the small handle, and then pulling the small handle a little bit outward to release it from the secured position. Then, open the other small handle **1** by following the same instructions. Ensure that the small handles are in the fully open position.

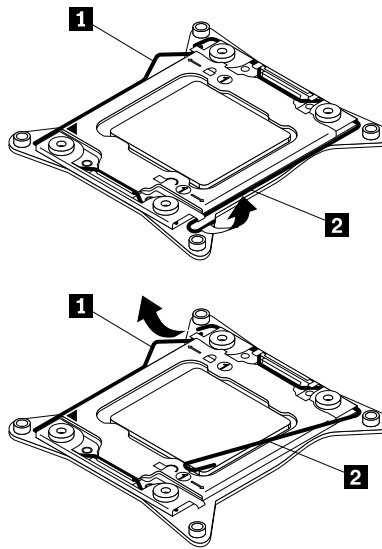

Figure 46. Opening the handles

7. Gently press down the small handle **2** to open the microprocessor retainer. Pivot the retainer upward until it is in the fully open position.

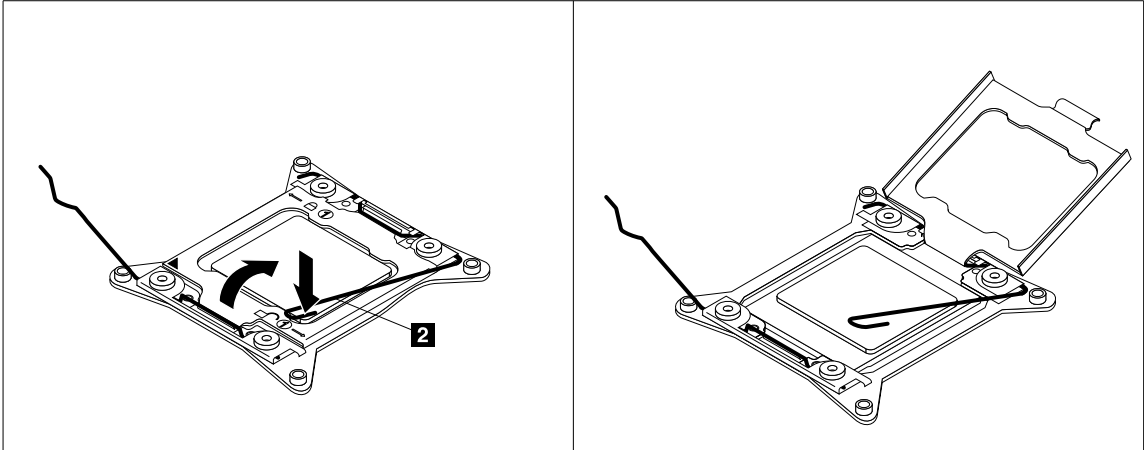

Figure 47. Opening the microprocessor retainer

8. Touch only the edges of the microprocessor and carefully lift it straight up and out of the microprocessor socket. Place the old microprocessor on a static-protective surface.

Notes:

- Do not touch the gold contacts on the bottom of the microprocessor.
- Do not drop anything onto the microprocessor socket while it is exposed. The socket pins must be kept as clean as possible.

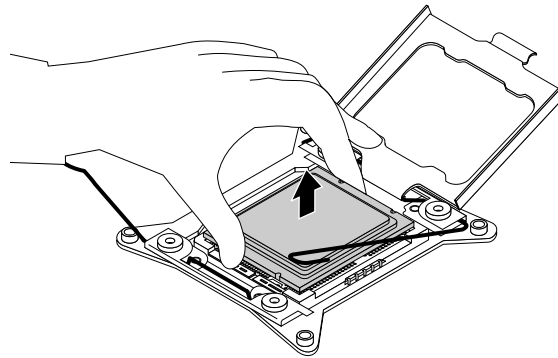

Figure 48. Removing the microprocessor

9. Touch the static-protective package that contains the new microprocessor to any unpainted surface on the outside of the computer. Then, remove the new microprocessor from the package.

10. Remove the new microprocessor from the protective cover that protects the gold contacts on the bottom of the new microprocessor. Do not touch the pins on the microprocessor socket or the gold contacts on the bottom of the new microprocessor.

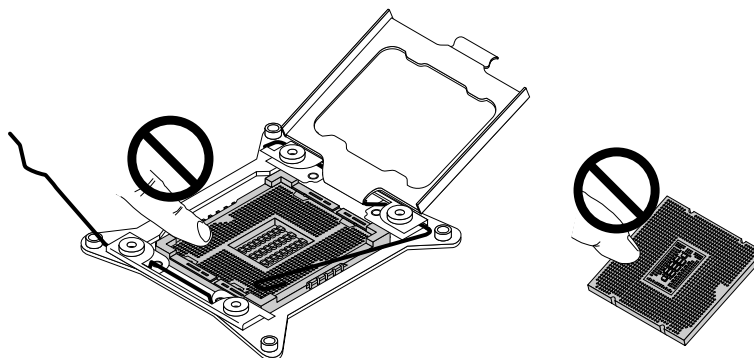

Figure 49. Do not touch the pins

11. Note the orientation of the new microprocessor. Hold the new microprocessor by its edges and align the notches **1** on it with the tabs **2** in the microprocessor socket. Then, carefully lower the new microprocessor straight down into the microprocessor socket.

Note: The small triangle **3** on one corner of the new microprocessor is the microprocessor orientation indicator. The new microprocessor is in the correct orientation when this indicator faces the beveled corner **4** of the microprocessor socket.

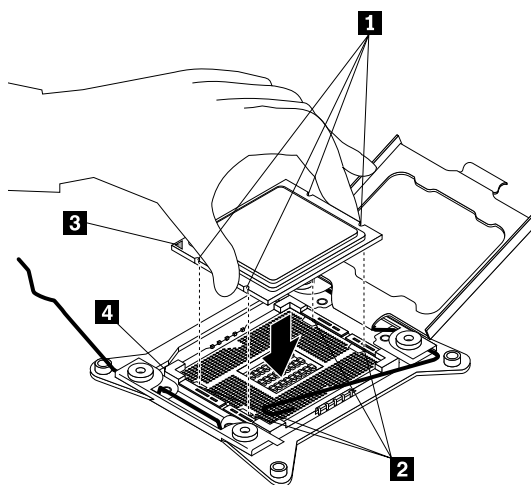

Figure 50. Installing the microprocessor

- Pivot the microprocessor retainer downward to close the retainer.

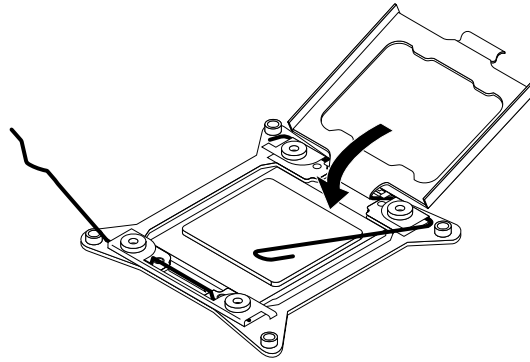



Figure 51. Closing the microprocessor retainer

- Gently press down the small handle **1**, and then push the handle inward to secure it. Then gently press down the small handle **2** and push the handle inward to lock the microprocessor retainer into position and secure the new microprocessor in the socket.

Note: There are two marks on the microprocessor retainer. Ensure that you close the small handle marked with  first, and then close the small handle marked with . Always follow the correct sequence when you close the small handles.

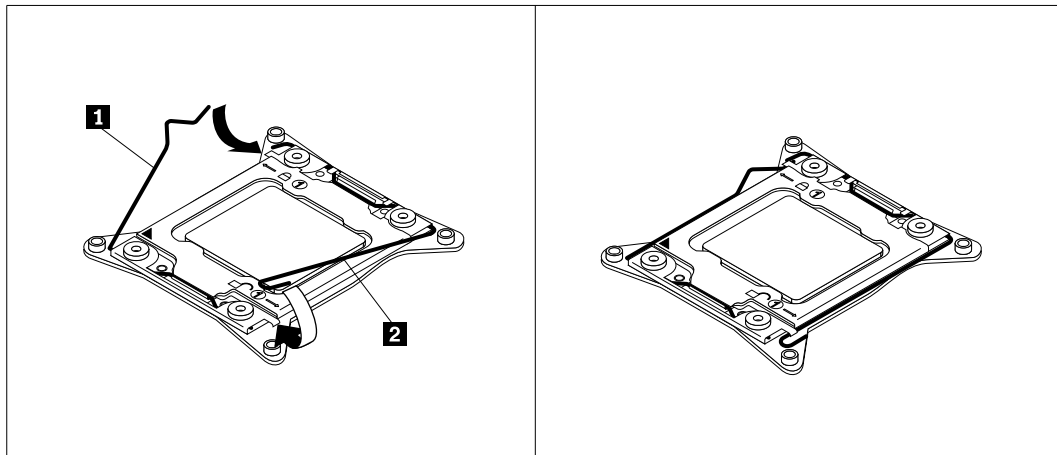

Figure 52. Securing the microprocessor in the socket

- Reinstall the heat sink and fan assembly. See “Replacing the heat sink and fan assembly” on page 98.
- If you are instructed to return the old microprocessor, follow all packaging instructions and use any packaging materials that are supplied to you for shipping.
- To complete the replacement, go to “Completing the parts replacement” on page 124.

Replacing the system board

Attention:

Do not open your computer or attempt any repair before reading and understanding the “Important Safety Information” on page 1.

This section provides instructions on how to replace the system board.

CAUTION:



The heat sink and microprocessor might be very hot. Before you open the computer cover, turn off the computer and wait several minutes until the computer is cool.

Note: Before replacing the system board, make sure you have a retention module for the new system board.

To replace the system board, do the following:

1. Remove all media from the drives and turn off all attached devices and the computer. Then, disconnect all power cords from electrical outlets and disconnect all cables that are connected to the computer.
2. Remove the computer cover. See “Removing the computer cover” on page 82.
3. Place the computer on its side to gain easier access to the system board.
4. Remove all memory modules and PCI cards that are currently installed. See “Installing or replacing a memory module” on page 89 and “Installing or replacing a PCI card” on page 84.
5. Remove the hard disk drive fan assembly. See “Replacing the hard disk drive fan assembly” on page 100.
6. Remove the hard disk drive enablement module if it is installed. See “Installing or replacing a hard disk drive enablement module” on page 107.
7. Remove the heat sink and fan assembly from the failing system board. See “Replacing the heat sink and fan assembly” on page 98.
8. Remove the microprocessor(s) from the failing system board. See “Replacing a microprocessor” on page 115.
9. Remove the battery from the failing system board. See “Replacing the battery” on page 97.
10. Note the location of all cable connections on the system board and disconnect all cables. See “Locating parts on the system board” on page 76.
11. Remove the ten screws that secure the system board to the chassis by following the sequence from **1** to **10**.

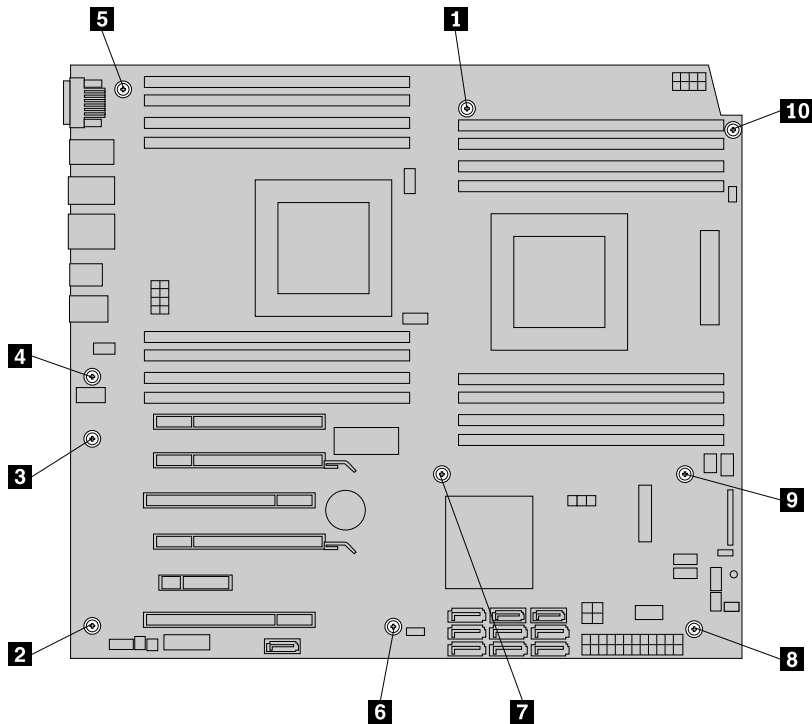

Figure 53. Removing the ten screws that secure the system board to the chassis

12. Carefully lift the failing system board out of the chassis.
13. Position the new system board into the chassis so that the screw holes in the new system board are aligned with those in the chassis. Install the ten screws that secure the system board to the chassis by following the sequence from **10** to **1**.
14. Remove the microprocessor socket cover(s) from the new system board.
15. Install the memory modules, PCI cards, battery, microprocessor, heat sink and fan assembly, hard disk drive enablement module (if applicable), and the hard disk drive fan assembly that you removed from the failing system board to the new system board.
16. Connect all cables to the system board. See “Locating parts on the system board” on page 76.
17. Go to “Completing the parts replacement” on page 124.

The failing system board must be returned with microprocessor socket covers to protect the pins during shipping and handling. Install the microprocessor socket covers removed from the new system board on the failing system board.

Note: The microprocessor socket cover installation procedure should be performed on both microprocessor sockets on the failing system board.

To install the microprocessor socket cover on the failing system board:

1. Pivot the microprocessor retainer downward to close the retainer.

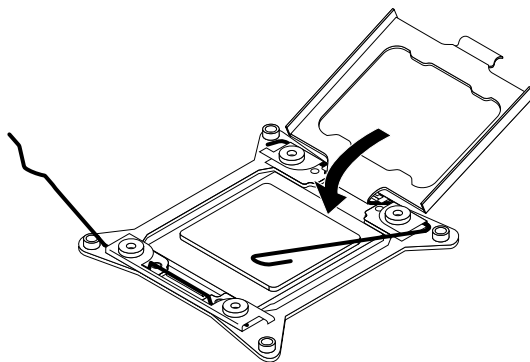

Figure 54. Closing the microprocessor retainer

2. Gently press down the small handle **1**, and then push the handle inward to secure it. Then gently press down the small handle **2** and push the handle inward to lock the microprocessor retainer into position.

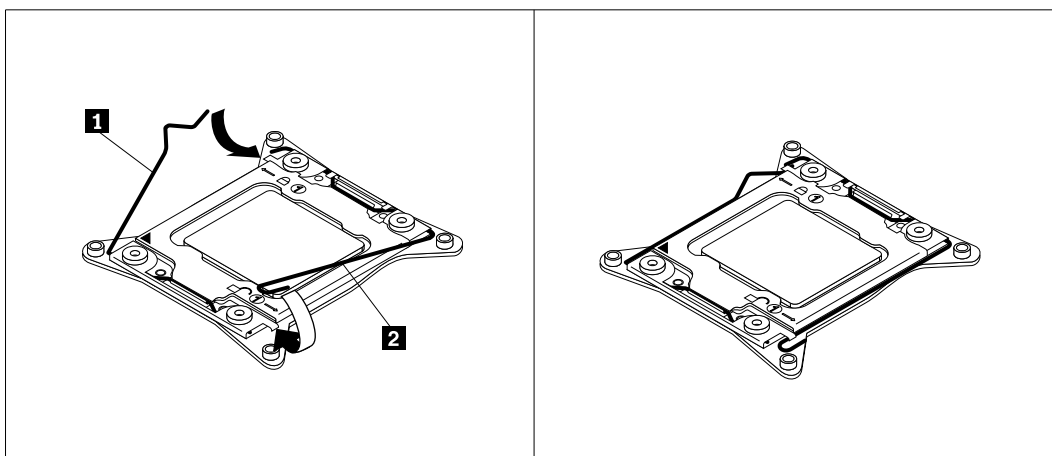

Figure 55. Securing the microprocessor in the socket

3. Align the notch **1** of the microprocessor socket cover with the alignment key **2** of the microprocessor socket. Lower the socket cover straight down into the microprocessor socket on the system board.

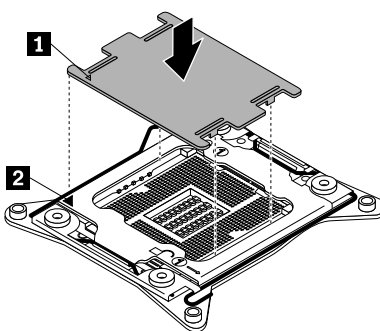

Figure 56. Installing the microprocessor socket cover

Note: Your microprocessor socket and cover might look slightly different from the illustration.

Replacing the power supply assembly

Attention:

Do not open your computer or attempt any repair before reading and understanding the “Important Safety Information” on page 1.

This document provides instructions on how to replace the power supply assembly.

CAUTION:

Never remove the cover on a power supply or any part that has the following label attached.

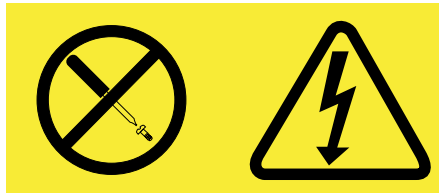

Hazardous voltage, current, and energy levels are present inside any component that has this label attached. There are no serviceable parts inside these components.

CAUTION:

Turn off the computer and wait three to five minutes to let the computer cool before removing the computer cover.

To replace the power supply assembly, do the following:

1. Remove all media from the drives and turn off all attached devices and the computer. Then, disconnect all power cords from electrical outlets and disconnect all cables that are connected to the computer.
2. Remove any locking device that secures the computer cover, such as a padlock or an integrated cable lock.
3. Remove the computer cover. See “Removing the computer cover” on page 82.
4. Place the computer on its side to gain easier access to the power supply.
5. Disconnect the power supply assembly cables from the system board and the drives. In some models, you might need to disconnect the power supply assembly cables from the Peripheral Component Interconnect (PCI) cards.
6. Remove the six screws that secure the power supply as shown in the following illustration.

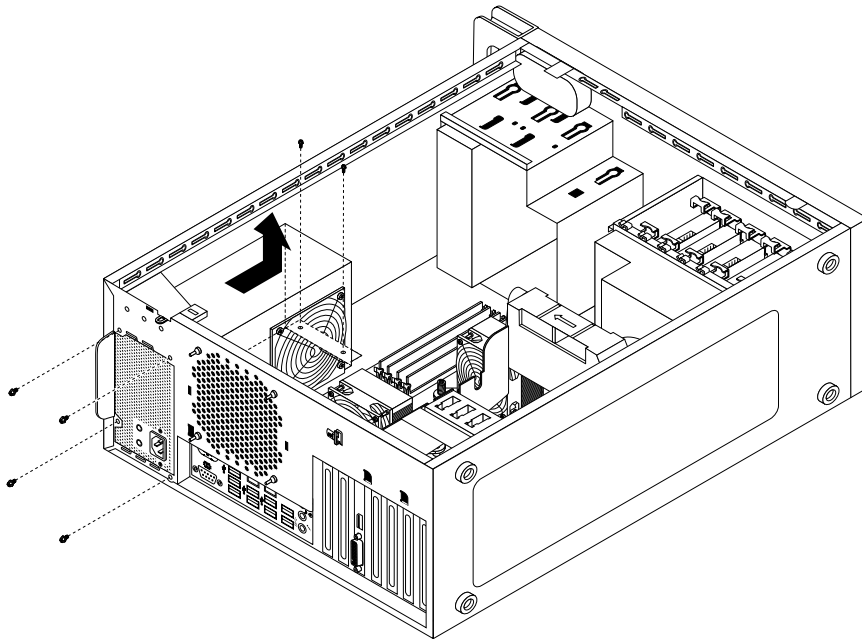

Figure 57. Removing six screws that secure the power supply assembly

7. Slide the power supply assembly toward the front of the computer and then lift it out of the chassis.
8. Install the new power supply assembly into the chassis, and make sure the screw holes in the new power supply assembly align with those in the chassis.
9. Install the six screws that secure the new power supply assembly in place.
10. Connect the power supply assembly cables to the system board and all drives. In some models, you might need to connect the power supply assembly cables to the PCI cards.
11. Return the computer to its original position.
12. To complete the installation or replacement, go to “Completing the parts replacement” on page 124.

Completing the parts replacement

After completing the installation or replacement for all parts, you need to reinstall the computer cover and reconnect cables. Depending on the parts you installed or replaced, you might need to confirm the updated information in the Setup Utility program. Refer to Chapter 6 “Using the Setup Utility program” on page 55.

To reinstall the computer cover and reconnect cables to your computer, do the following:

1. Ensure that all components have been reassembled correctly and that no tools or loose screws are left inside your computer. See “Locating major FRUs and CRUs” on page 74 for the locations of various components in your computer.
2. If you have removed the front bezel, reinstall it.
3. Ensure that the cables are routed correctly before reinstalling the computer cover. Keep cables clear of the hinges and sides of the computer chassis to avoid interference with reinstalling the computer cover.
4. Align the cover with the chassis, and then close the cover to engage the cover latch. Use the keys attached at the rear of your computer to lock the keylock that is built into the computer cover.
5. If there is a padlock available, lock the computer cover.
6. If there is an integrated cable lock available, lock the computer..

7. Reconnect the external cables and power cords to the computer. See “Locating connectors on the rear of your computer” on page 74.
8. To update your configuration, refer to Chapter 6 “Using the Setup Utility program” on page 55.

Note: In most areas of the world, Lenovo requires the return of the defective Customer Replaceable Unit (CRU). Information about this will come with the CRU or will come a few days after the CRU arrives.

Obtaining device drivers

You can obtain device drivers for operating systems that are not preinstalled at <http://www.lenovo.com/support>. Installation instructions are provided in readme files with the device-driver files.

Chapter 11. Additional service information

This chapter provides additional information that the service representative might find helpful.

Security features

Security features in this section include the following:

- Passwords
- Vital Product Data
- Management Information Format (MIF)

Hardware-controlled passwords

Hardware-controlled passwords are set using the Setup Utility program. For more information about passwords, see “Using passwords” on page 55.

Operating system password

An operating system password is very similar to a power-on password and denies access to the computer by an unauthorized user when the password is activated. The computer is unusable until the password is entered and recognized by the computer.

Vital product data

Each computer has a unique Vital Product Data (VPD) code stored in the nonvolatile memory on the system board. After you replace the system board, the VPD must be updated. To update the VPD, see “Updating (flashing) the BIOS” on page 127.

BIOS levels

An incorrect level of BIOS can cause false errors and unnecessary FRU replacement. Use the following information to determine the current level of BIOS installed in the computer, the latest BIOS available for the computer, and where to obtain the latest level of BIOS.

- To determine the current Level of BIOS:
 - Start the Setup Utility program.
- Sources for obtaining the latest level BIOS available
 1. Lenovo support web site: <http://www.lenovo.com/support>
 2. Lenovo Customer Support Center
 3. Levels 1 and 2 Support

To update (flash) the BIOS, see “Updating (flashing) the BIOS” on page 127.

Note: BIOS settings vary by operating system. Change the BIOS settings before installing a new operating system. See “Changing the BIOS settings before installing a new operating system” on page 59.

Updating (flashing) the BIOS

This section provides instructions on how to update the BIOS for your computer.

Updating (flashing) the BIOS from a disc

This section provides instructions on how to update (flash) the BIOS from a disc.

Note: You can download a self-starting bootable disc image (known as an ISO image) with the system program updates to create a system-program-update disc. Go to <http://www.lenovo.com/support>.

To update (flash) the BIOS from a disc on the Windows 8 (64-bit) or Windows 8.1 (64-bit) operating system, do the following:

1. Start the Setup Utility program. See “Starting the Setup Utility program” on page 55.
2. From the Setup Utility program main menu, select **Exit → OS Optimized Default → Disabled**.
3. Select **Yes** in the window displayed and press Enter to confirm your selection.
4. Press F10 to save changes and exit the Setup Utility program. See “Exiting the Setup Utility program” on page 59.
5. Repeatedly press and release F12 when turning on the computer. When the Startup Device Menu window opens, release F12.
6. From the Startup Device Menu window, select the desired optical drive as the startup device. Then, insert the disc into this optical drive and press Enter. The update begins.
7. When prompted to change the serial number, it is suggested that you do not make this change by pressing N. However, if you do want to change the serial number, press Y, and then type in the serial number and press Enter.
8. When prompted to change the machine type and model, it is suggested that you do not make this change by pressing N. However, if you do want to change the machine type and model, press Y, and then type in the machine type and model and press Enter.
9. Follow the instructions on the screen to complete the update. After the update is completed, remove the disc from the optical drive.
10. Restart your computer and start the Setup Utility program. See “Starting the Setup Utility program” on page 55.
11. From the Setup Utility program main menu, select **Exit → OS Optimized Default → Enabled**.
12. Select **Yes** in the window displayed and press Enter to confirm your selection.
13. Press F10 to save changes and exit the Setup Utility program. See “Exiting the Setup Utility program” on page 59.

To update (flash) the BIOS from a disc on other operating systems, do the following:

1. Turn off your computer.
2. Repeatedly press and release F12 when turning on the computer. When the Startup Device Menu window opens, release F12.
3. From the Startup Device Menu window, select the desired optical drive as the startup device. Then, insert the disc into this optical drive and press Enter. The update begins.
4. When prompted to change the serial number, it is suggested that you do not make this change by pressing N. However, if you do want to change the serial number, press Y, and then type in the serial number and press Enter.
5. When prompted to change the machine type and model, it is suggested that you do not make this change by pressing N. However, if you do want to change the machine type and model, press Y, and then type in the machine type and model and press Enter.
6. Follow the instructions on the screen to complete the update. After the update is completed, remove the disc from the optical drive.

Updating (flashing) the BIOS from your operating system

Note: Because Lenovo makes constant improvements to its Web sites, the Web page contents are subject to change without notice, including the contents referenced in the following procedure.

To update (flash) the BIOS from your operating system, do the following:

1. Go to <http://www.lenovo.com/support>.
2. Do the following to locate the downloadable files for your machine type:
 - a. In the **Enter a product number** field, type your machine type and click **Go**.
 - b. Click **Downloads and drivers**.
 - c. Select **BIOS** from the **Refine results** drop-down list box to easily locate all the BIOS related links.
 - d. Click the BIOS update link.
3. Click the TXT file that contains the instructions for updating (flashing) the BIOS from your operating system.
4. Print these instructions. This is very important because these instructions will not be displayed on the screen after the download begins.
5. Follow the printed instructions to download, extract, and install the update.

Recovering from a POST/BIOS update failure

If the power to your computer is interrupted while the POST and BIOS is being updated, your computer might not restart correctly. If this happens, perform the following procedure to recover from the POST and BIOS update failure. This procedure is commonly called Boot-block Recovery.

1. Remove all media from the drives and turn off all attached devices and the computer. Then, disconnect all power cords from electrical outlets and disconnect all cables that are connected to the computer.
2. Remove the computer cover. See “Removing the computer cover” on page 82.
3. Locate the Clear CMOS /Recovery jumper on the system board. See “Locating parts on the system board” on page 76.
4. Remove any cables that impede access to the Clear CMOS /Recovery jumper.
5. Move the jumper from the standard position (pin 1 and pin 2) to the maintenance position (pin 2 and pin 3).
6. Reconnect any cables that were disconnected and reinstall the PCI card if removed.
7. Reinstall the computer cover and reconnect the power cords for the computer and monitor to electrical outlets. See “Completing the parts replacement” on page 124.
8. Turn on the computer and then insert the POST and BIOS update (flash update) disc into the optical drive. Wait a few minutes. Then, the recovery session begins. The recovery session will take two to three minutes. During this time, a warning message will be displayed and no action is needed from you.
9. After the recovery session is completed, there will be no video, and your computer will automatically turn off.
10. Repeat step 1 through step 4.
11. Move the Clear CMOS /Recovery jumper back to the standard position (pin 1 and pin 2).
12. Reconnect any cables that were disconnected and reinstall the PCI card if removed.
13. Reinstall the computer cover and reconnect any cables that were disconnected.
14. Turn on the computer to restart the operating system.

Power management

Power management reduces the power consumption of certain components of the computer such as the system power supply, processor, hard disk drives, and some monitors.

Advanced configuration and power interface (ACPI) BIOS

Being an ACPI BIOS system, the operating system is allowed to control the power management features of the computer and the setting for Advanced Power Management (APM) BIOS mode is ignored. Not all operating systems support ACPI BIOS mode.

Automatic Power-On features

The Automatic Power-On features within the Power Management menu allow you to enable and disable features that turn on the computer automatically.

- **Serial Port A Ring Detect:** With this feature set to **Enabled** and an external modem connected to serial port (COM1), the computer will turn on automatically when a ring is detected on the modem.
- **PCI Modem Ring Detect:** With this feature set to **Enabled**, the computer will turn on automatically when a ring is detected on the internal modem.
- **PCI Wake Up:** This feature allows PCI cards that support this capability to wake the system.
- **Wake Up on Alarm:** You can specify a date and time at which the computer will be turned on automatically. This can be either a single event or a daily event.
- **Wake on LAN:** If the computer has a properly configured token-ring or Ethernet LAN adapter card that is Wake on LAN-enabled and there is remote network management software, you can use the Wake on LAN feature. When you set Wake on LAN to **Enabled**, the computer will turn on when it receives a specific signal from another computer on the local area network (LAN).

To enable the Wake on LAN function or the Wake Up on Alarm function on the Windows 8 or Windows 8.1 operating system, do the following:

1. Open Control Panel.
2. Click **Hardware and Sound → Power Options**.
3. In the left panel, do one of the following:
 - For Windows 8: Click **Choose what the power buttons do**.
 - For Windows 8.1: Click **Choose what the power button does**.
4. In the **Shutdown setting** section, clear **Turn on fast startup**.

Note: If the settings are unavailable, click **Change settings that are currently unavailable**.

5. Click **Save changes**.

System memory speed

The Intel Xeon microprocessor families compatible with this ThinkStation computer feature an integrated memory controller, which provides the microprocessor with direct access to the system memory. Because of this design, the system memory speed will be determined by a number of factors, including the microprocessor model and the type, speed, size (capacity), and number of DIMMs installed. Refer to the following table for the information on the supported system memory speed for your own computer model.

Table 3. DIMM type and speed: PC3-10600E

DIMM operating voltage	Microprocessor model	Memory frequency
1.5 V	Intel Xeon E5-1603, E5-2603, E5-2609	1066 MHz
	Intel Xeon E5-2620, E5-2630/2630L, E5-2637, E5-2640, E5-2643, E5-2667, E5-2650/2650L, E5-2660, E5-2665, E5-2670, E5-2680, E5-2685, E5-2690	1333 MHz

Table 4. DIMM type and speed: PC3-10600R

DIMM operating voltage	Microprocessor model	Memory frequency
1.5 V	Intel Xeon E5-1603	1066 MHz
1.35 V, 1.5 V	Intel Xeon E5-2603, E5-2609	1066 MHz
	Intel Xeon E5-2620, E5-2630/2630L, E5-2637, E5-2640, E5-2643, E5-2667, E5-2650/2650L, E5-2660, E5-2665, E5-2670, E5-2680, E5-2685, E5-2690	1333 MHz

Table 5. DIMM type and speed: PC3-12800R

DIMM operating voltage	Microprocessor model	Memory frequency
1.35 V	Intel Xeon E5-2603, E5-2609	1066 MHz
	Intel Xeon E5-2620, E5-2630/2630L, E5-2637, E5-2640, E5-2643, E5-2650/2650L, E5-2660, E5-2665, E5-2667, E5-2670, E5-2680, E5-2685, E5-2690,	1333 MHz
1.5 V	Intel Xeon E5-1603, E5-2603, E5-2609	1066 MHz
	Intel Xeon E5-2620, E5-2630/2630L, E5-2640, E5-2667	1333 MHz
	E5-2637, E5-2643, E5-2650/2650L, E5-2660, E5-2665, E5-2670, E5-2680, E5-2685, E5-2690,	1600 MHz

Table 6. DIMM type and speed: PC3-14900E

DIMM operating voltage	Microprocessor model	Memory frequency
1.5 V	Intel Xeon E5-2690V2, E5-2680V2, E5-2670V2, E5-2660, E5-2650V2	1866 MHz
	Intel Xeon E5-2697V2, E5-2695V2, E5-2687V2, E5-2667V2, E5-2643V2, E5-2637V2	
	Intel Xeon E5-1660V2, E5-1650V2, E5-1620V2, E5-2660V2	
	Intel Xeon E5-2640V2, E5-2630V2, E5-2620V2	1600 MHz
	Intel Xeon E5-2650L, E5-2630L	
	Intel Xeon E5-1607V2	

Table 6. DIMM type and speed: PC3-14900E (continued)

DIMM operating voltage	Microprocessor model	Memory frequency
	Intel Xeon E5-2609V2, E5-2603V2	1333 MHz

Table 7. DIMM type and speed: PC3-14900R

DIMM operating voltage	Microprocessor model	Memory frequency
1.5 V	Intel Xeon E5-2690V2, E5-2680V2, E5-2670V2, E5-2660, E5-2650V2	1866 MHz
	Intel Xeon E5-2697V2, E5-2695V2, E5-2687V2, E5-2667V2, E5-2643V2, E5-2637V2,	
	Intel Xeon E5-1660V2, E5-1650V2, E5-1620V2, E5-2660V2	
	Intel Xeon E5-2640V2, E5-2630V2, E5-2620V2	1600 MHz
	Intel Xeon E5-2650L, E5-2630L	
	Intel Xeon E5-1607V2	
	Intel Xeon E5-2609V2, E5-2603V2	
		1333 MHz

Table 8. DIMM type and speed: PC3-15000

DIMM operating voltage	Microprocessor model	Memory frequency
1.5 V	Intel Xeon E5-1680V2	1866 MHz

Appendix A. Notices

Lenovo may not offer the products, services, or features discussed in this document in all countries. Consult your local Lenovo representative for information on the products and services currently available in your area. Any reference to a Lenovo product, program, or service is not intended to state or imply that only that Lenovo product, program, or service may be used. Any functionally equivalent product, program, or service that does not infringe any Lenovo intellectual property right may be used instead. However, it is the user's responsibility to evaluate and verify the operation of any other product, program, or service.

Lenovo may have patents or pending patent applications covering subject matter described in this document. The furnishing of this document does not give you any license to these patents. You can send license inquiries, in writing, to:

*Lenovo (United States), Inc.
1009 Think Place - Building One
Morrisville, NC 27560
U.S.A.
Attention: Lenovo Director of Licensing*

LENOVO PROVIDES THIS PUBLICATION "AS IS" WITHOUT WARRANTY OF ANY KIND, EITHER EXPRESS OR IMPLIED, INCLUDING, BUT NOT LIMITED TO, THE IMPLIED WARRANTIES OF NON-INFRINGEMENT, MERCHANTABILITY OR FITNESS FOR A PARTICULAR PURPOSE. Some jurisdictions do not allow disclaimer of express or implied warranties in certain transactions, therefore, this statement may not apply to you.

This information could include technical inaccuracies or typographical errors. Changes are periodically made to the information herein; these changes will be incorporated in new editions of the publication. Lenovo may make improvements and/or changes in the product(s) and/or the program(s) described in this publication at any time without notice.

The products described in this document are not intended for use in implantation or other life support applications where malfunction may result in injury or death to persons. The information contained in this document does not affect or change Lenovo product specifications or warranties. Nothing in this document shall operate as an express or implied license or indemnity under the intellectual property rights of Lenovo or third parties. All information contained in this document was obtained in specific environments and is presented as an illustration. The result obtained in other operating environments may vary.

Lenovo may use or distribute any of the information you supply in any way it believes appropriate without incurring any obligation to you.

Any references in this publication to non-Lenovo Web sites are provided for convenience only and do not in any manner serve as an endorsement of those Web sites. The materials at those Web sites are not part of the materials for this Lenovo product, and use of those Web sites is at your own risk.

Any performance data contained herein was determined in a controlled environment. Therefore, the result obtained in other operating environments may vary significantly. Some measurements may have been made on development-level systems and there is no guarantee that these measurements will be the same on generally available systems. Furthermore, some measurements may have been estimated through extrapolation. Actual results may vary. Users of this document should verify the applicable data for their specific environment.

Television output notice

The following notice applies to models that have the factory-installed television-output feature.

This product incorporates copyright protection technology that is protected by method claims of certain U.S. patents and other intellectual property rights owned by Macrovision Corporation and other rights owners. Use of this copyright protection technology must be authorized by Macrovision Corporation, and is intended for home and other limited viewing uses only unless otherwise authorized by Macrovision Corporation. Reverse engineering or disassembly is prohibited.

European conformance CE mark

The emission notices information is available in the *ThinkStation Safety, Warranty, and Setup Guide* that came with your computer.



Trademarks

The following terms are trademarks of Lenovo in the United States, other countries, or both:

- Lenovo
- The Lenovo logo
- Rescue and Recovery
- ThinkStation
- ThinkVantage

Microsoft and Windows are trademarks of the Microsoft group of companies.

Intel and Intel Xeon are trademarks of Intel Corporation in the United States, other countries, or both.

DisplayPort and mini DisplayPort are Trademarks of the Video Electronics Standards Association.

Linux is a trademark of Linus Torvalds in the United States, other countries, or both.

Other company, product, or service names may be trademarks or service marks of others.

Index

A

Administrator, password 56

B

basic troubleshooting 35
battery, replacing 97, 123
BIOS settings, changing 59
boot-block recovery 129

C

card reader, replacing 95
changing
 password 56
 startup device sequence 58
cleaning an optical mouse 43
CMOS, clearing 57
components, internal 74
computer cover
 removing 82
computer cover, reinstalling 124
connectors
 rear 74
connectors, controls, indicators
 front 73
considerations, passwords 56
CRU, returning defective 124
CRUs (Customer Replacable Units), returning defective 74

D

deleting a password 56
device drivers 125
devices, handling static-sensitive 81
diagnostics, troubleshooting 35
drivers, device 125
drives
 bays 79
 specifications 79

E

environment, operating 29
exiting, Setup Utility 59
external options, installing 81

F

failure, recovering from POST/BIOS 129
flashing the BIOS 128
front
 connectors, controls, indicators 73
front audio and USB assembly, replacing 108

front bezel
 front bezel, removing 83
front bezel, reinstalling 83
FRU locations 74
FRU part numbers 1, 73, 76, 81

H

hard disk drive enablement module, replacing 107
hard disk drive fan assembly, replacing 100
hard disk drive, replacing 103
heat sink and fan assembly, replacing 98

I

Identifying FRUs 74
installing
 microprocessor 111
 operating system 59
installing options
 memory module 89
 PCI card 84
installing, replacing
 mSATA solid-state drive 87
internal speaker, replacing 109

L

Lenovo Solution Center 53
locating components 74
looking up part numbers 1, 73, 76, 81

M

memory module
 installing, replacing 89
 system board 89
memory speed 130
microprocessor
 installing 111
mSATA solid-state drive
 installing, replacing 87

O

optical drive, replacing 92
optical mouse
 cleaning 43
Optional-service CRUs 74

P

part numbers 1, 73, 76, 81

- parts replacement, completing 124
- password
 - Administrator 56
 - considerations 56
 - Power-On Password 56
 - setting, changing, deleting 56
- passwords
 - erasing 57
 - lost or forgotten 57
- passwords, using 55
- PCI card 84
 - installing, replacing 84
 - slots 84
- physical specifications 29
- Power-On, Password 56

R

- rear connectors 74
- rear fan assembly, replacing 101
- recovering
 - from a POST/BIOS update failure 129
- recovery
 - boot-block 129
- removing computer cover 82
- replacing
 - battery 97, 123
 - card reader 95
 - hard disk drive 103
 - hard disk drive enablement module 107
 - heat sink and fan assembly 98

S

- security
 - enabling or disabling 57
- selecting
 - startup device 57
 - temporary startup device 58
- Self-service CRUs 74
- setting
 - password 56
- settings
 - changing 55
 - viewing 55
- Setup Utility 55
- Setup Utility program, starting 55
- Setup Utility, exiting 59
- speed, memory 130
- starting the Setup Utility program 55
- startup device 57
 - sequence, changing 58
 - temporary, selecting 58
- static-sensitive devices, handling 81
- support web site
 - support 31
- support, web site 31
- system board
 - locating parts 76
 - locations 76

- memory module 89

T

- temporary startup device 58
- the BIOS, updating (flashing) 128–129
- trademarks 134
- troubleshooting, basic 35
- troubleshooting, diagnostics 35

U

- updating
 - (flashing) the BIOS 128
 - updating (flashing) the BIOS 129
- using
 - passwords 55
 - Setup Utility 55

V

- viewing and changing settings 55

lenovo[®]